

Quick Start Guide ER450 Data Radio

1.0 Introduction

Welcome to the *Quick Start Guide for the ER450 Data Radio*. This guide provides step-by-step instructions, with simple explanations to get you up-and-running. For further information, please refer to the *E Series User Manual*.



Related Products and Documentation

- Base Station EB450
- Hot Standby Base Station EH450
- Digital Order Wire Voice Module EDOVM
- Duplexers
- TVIEW+ Management Suite
- E Series User Manual

Contents

| | |
|--|---|
| 1.0 Introduction..... | 1 |
| 2.0 Mounting and Environmental Considerations..... | 2 |
| 3.0 Connecting Antennas and RF Feeders..... | 3 |
| 4.0 Communications Ports..... | 4 |
| 5.0 Power Supply and Protection..... | 5 |
| 6.0 TVIEW+ Management Suite..... | 7 |
| 7.0 Optimising the Antenna for VSWR..... | 6 |
| 8.0 LED Indicators and Test Outputs..... | 6 |
| 9.0 Verifying Operational Health..... | 7 |
| 10.0 Support Options..... | 8 |



2.0 Mounting and Environmental Considerations

The ER450 radio comes complete with a mounting cradle and is attached to a panel or tray by means of screws or bolts, using the hole slots provided.

Note: In high power or high temperature applications, it is desirable to mount the radio with the heatsink uppermost to allow ventilation for the heatsink.

The radio should be mounted in a clean and dry location, protected from water, excessive dust, corrosive fumes, extremes of temperature and direct sunlight. Please allow sufficient passive or active ventilation to allow the radio modem's heatsink to operate efficiently.

2.2 ER450 Connections Layout

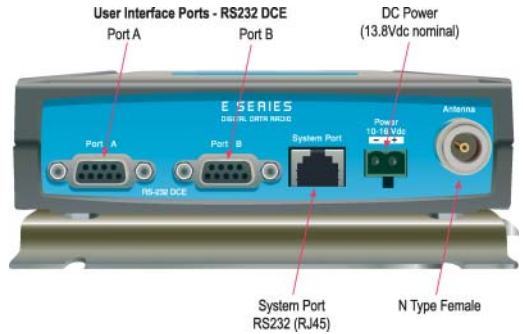

Fig 4

2.1 Typical Radio Setup

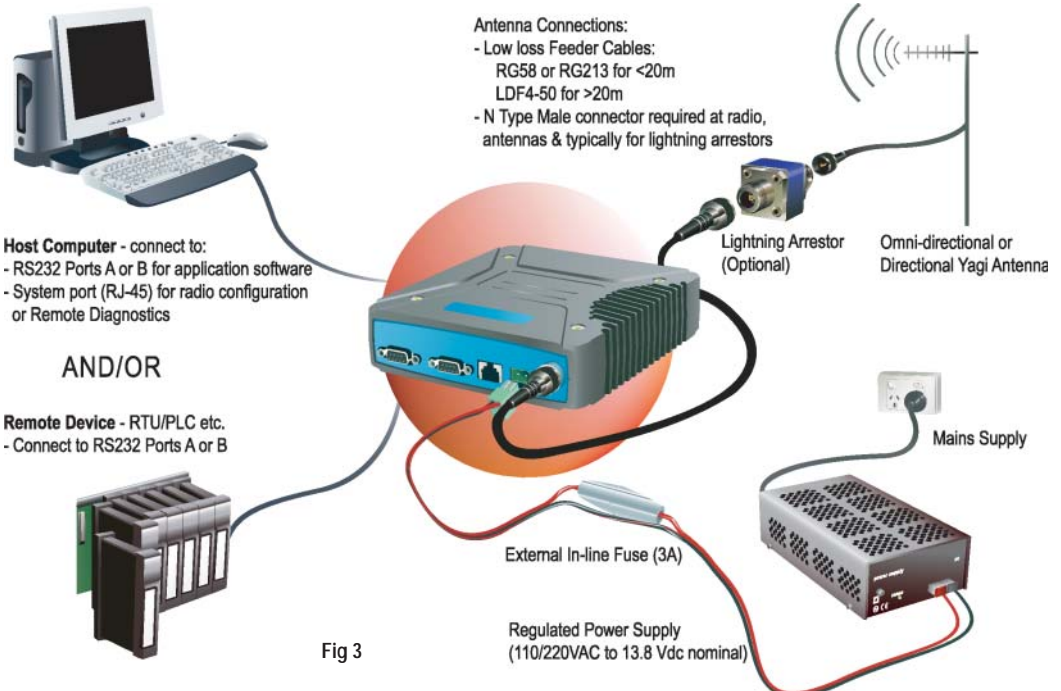

Fig 3

3.0 Connecting Antennas and RF Feeders

The RF antenna system should be installed in accordance with the manufacturers notes.

The RF connector used on the ER450 radio is an N Type female connector. Always use good quality low loss feeder cable, selected according to the length of the cable run. Ensure all external connections are waterproofed using amalgamating tape.

Preset directional antennas in the required direction using a compass, GPS, or visual alignment and ensure correct polarisation (vertical or horizontal).



Fig 5

4.0 Communications Ports

4.1 System Port - RJ45

The System Port is a multi-function interface used for:

- Programming / Configuration of the radio
- Remote Diagnostics connections

To access these functions use the standard ER450 System Cable assembly (RJ45 Cable and RJ45 to DB9 Adaptor).

System Port pinout assignments:

| | |
|-------|------------------------------|
| Pin 1 | System port data out (RS232) |
| Pin 2 | System port data in (RS232) |
| Pin 3 | Not used |
| Pin 4 | Shutdown |
| Pin 5 | Not used |
| Pin 6 | Not used |
| Pin 7 | Ground |
| Pin 8 | External PTT |

Special user pinouts:

- Shutdown (Pin 4) - Active low for power save function
- External PTT (Pin 8) - Provides a manual PTT override facility for enabling the transmitter. For testing this can be activated by connecting PTT (Pin 8) to Gnd (Pin 7).

Fig 6

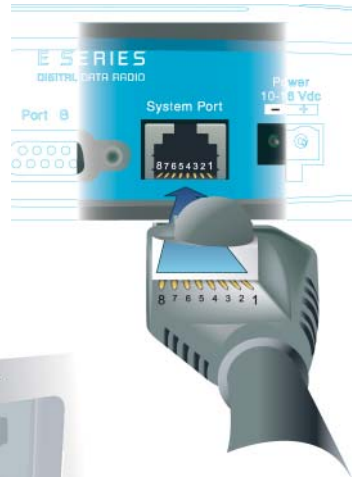

Fig 7

4.2 User Interfaces - Ports A & B

Each user port (A & B) is wired as a RS232 DCE, configurable for no handshaking (3-wire) interface, or for hardware or software (X-on/X-off) flow control. In most systems flow control is not required, in which case only 3 wires need to be connected between the radio and the application device.

4.3 Typical pins used:

- Pin 2 (RxD) - data output from the radio modem,
- Pin 3 (TxD) - data input to the radio modem,
- Pin 5 (SG) - signal ground.

Refer to User Manual for further details of other cable configurations.

RS232 Connector Pin outs (DCE) Port A and B, Female DB9

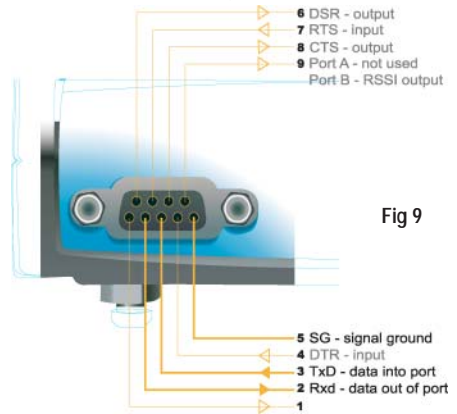

Fig 9

Radio (DCE) - Connection to RTU / PLC or Computer (DTE, DB9)

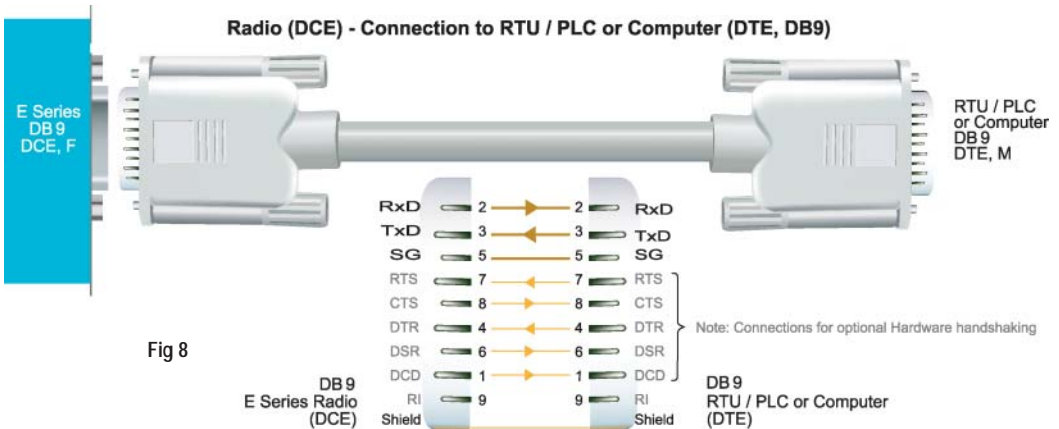

Fig 8

4.4 Activating the Transmitter

In most systems, the transmitter by default is controlled automatically by the radio when it has data to transmit. In some systems, such as full duplex point-to-point links or full duplex point-to-multipoint base stations, it is desirable to run the transmitter all the time (hot keyed).

Two mechanisms are provided to do this:

- the radio modem can be configured to transmit continuously whenever powered, or

- the radio modem can be configured to transmit whenever an external RTS signal (Pin 7) is applied to one (or either) user ports. (To simulate an external RTS input, loop pins 6 to 7).

To operate in these modes, the radio must be configured via the programming software.

⚠ Caution: When the radio is configured to transmit continuously, ensure an RF load is present BEFORE applying power to the unit.

5.0 Power Supply and Protection (fusing)

The ER450 radio modem is designed and calibrated to operate from a 13.8Vdc regulated supply, but will operate from 10-16 volts (filtered) DC.

The current requirement is typically 120mA in receive mode, and will vary in transmit mode according to RF output power level (typically 0.5-1.5 amps).

⚠ Caution: There is **NO** internal replaceable fuse, and therefore the radio modem **MUST** be externally fused with the fuse holder provided (a 3 amp slo-blow fuse).

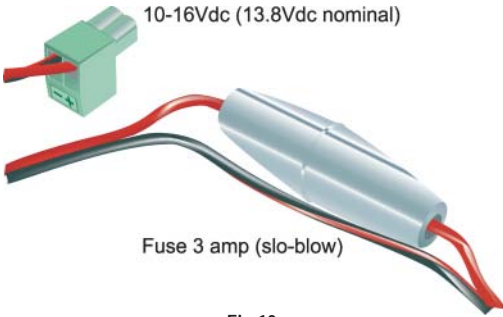

Fig 10

The radio is designed to self protect, and will blow the external fuse if the voltage exceeds 16Vdc, or if reverse polarity is applied.

The radio modem can also be damaged if there is any potential difference between the chassis-ground, RS232 signal ground, power (-) input, or antenna coaxial shield. Before connecting any wiring, ensure all components are earthed to a common ground point (please pay particular attention to 24V PLC power systems where converters are used).

Connect the antenna and RS 232 plugs BEFORE applying power to the unit.

Lastly, before inserting the power plug, please **re-check** that the polarity and voltage on the DC power plug is correct using a multimeter.

6.0 TVIEW+ Management Suite - Radio Configuration

This TVIEW+ Management Suite allows a number of features including: Configuration (Local - serial, or Remote - over-the-air), Remote Diagnostics Facilities and Firmware Upgrades.

The configuration wizard can be used to provide Quick Start generic templates for the types of systems architecture you wish to employ.

Example: Local configuration session -

1 Attach the programming cable from the PC to the System Port of the radio (see fig 6 & 7)

2 Launch TVIEW & Select "Programmer" 

3 Select "Read" the radio 

4 Change the configuration as required

5 Select "Write" the parameters back to the radio 

Refer to User Manual for detailed operation of advanced features.

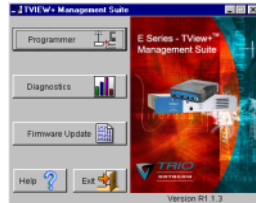

7.0 Optimising the Antenna for VSWR and best RX signal

Once the unit is operational, it is important to optimise the antenna tuning.

In the case of a directional antenna, it will be necessary to align the antenna for the best received signal.

This can be done by using the (0-5Vdc) output on Pin 9 (see fig 11) of Port B to indicate signal strength (RSSI). This voltage can be converted to dBm using the chart below.

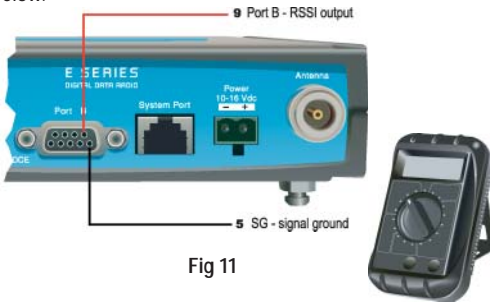
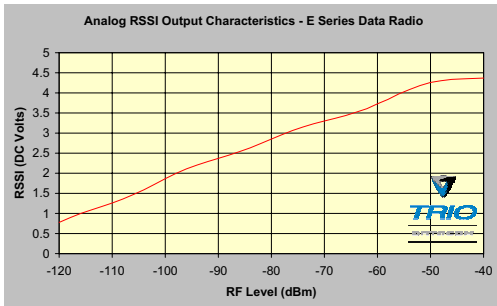

Fig 11



VSWR testing is achieved by activating the radio's transmitter using:

- An RTS loop as described in Section 4.4, or
 - A system port PTT plug as described in Section 4.1
- Refer to the User Manual for further details of VSWR testing.

8.0 LED Indicators & Test outputs

8.1 Radio is Powered

If all the LEDs are off, no power is reaching the radio modem.

Successful power-up is indicated by the "PWR" LED indicating a continuous (healthy) GREEN state. Note that this LED is turned RED when the transmitter is active.

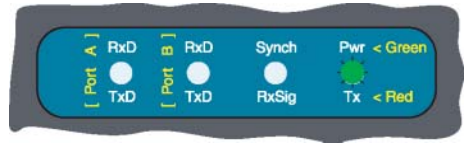

8.2 Voltage Error

If the voltage is too high (>16Vdc) or too low (<10Vdc), an error message will be displayed as a sequence of all LEDs flashing RED, followed by the green power LED, repeating about three times per second.

8.3 Hardware Error

A hardware error is indicated by a slower sequence of all LEDs flashing RED, followed by one or more of the other LEDs flashing green, the cycle repeating about once per second. In the case of a hardware error, the unit must be returned to the service point for repair. In this case please consult the User Manual for further information on the error indicated, and record the result with the service return information.

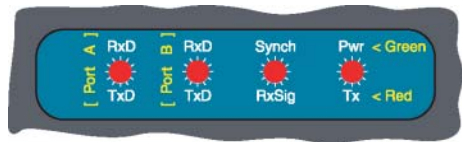

LED Legend



8.4 Received Signal Indicator

The “RX/SYNC” LED is used to indicate the state of the receiver.

If the LED is off, no signal is being received.

A RED indication shows that an RF carrier is being received, but no data stream can be decoded. This will briefly happen at the very start of every valid received transmission or may indicate the presence of interference, or another user on the channel.

A continuous GREEN indication shows that the modem is locked and synchronised to the incoming signal, and has excellent Bit Error Rate (BER). Any losses of synchronisation (BER errors) are shown as a visible RED flicker of the LED.

Note: This may only be apparent on a PTMP slave when only receiving.

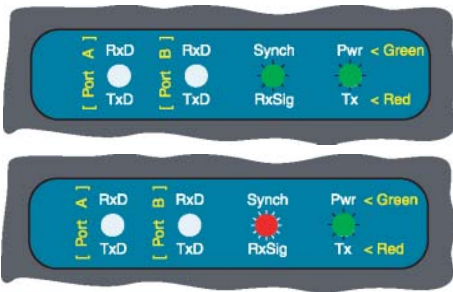

8.5 Data Flow “breakout” LEDs

There are also two LEDs to indicate data flow into and out of the two user ports.

Input data to be transmitted is shown as a RED flash, and received data to be output to the port is shown as a GREEN flash.

If data is alternately flowing in and out quickly, then the indicator appears orange.

9.0 Verifying Operational Health

It is possible to verify the operation of the radio modem using the indicators provided by the unit. The state of the transmitter and receiver, and data flow can be interpreted by the indicator LEDs (see below).

Note: Port A & B's RxD & TxD will be Active on Data Flow

Full Duplex - PTP Master or Slave

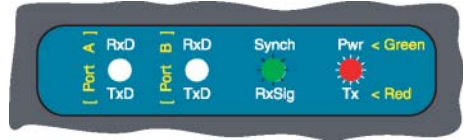

Full Duplex - PTMP Master Tx



Half Duplex - PTMP Slave Rx



Half Duplex - Master or Slave (Tx)



Half Duplex - Master or Slave (Rx)

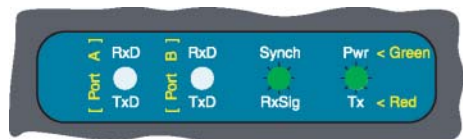

LED Legend



10.0 Support Options

10.1 Website Information

The Trio DataCom website support page contains links to e-mail and telephone support, tech notes, manuals, software updates.

Please go to www.trio.com.au/support.htm.

10.2 E-mail Technical Support

E-mail your questions to support@trio.com.au.

When e-mailing questions to our support staff, make sure you tell us the exact model number (and serial number if possible) of the Trio equipment you are working with. Include as much detail as possible about the situation, and any tests that you have done which may help us to better understand the issue. If possible, please include your telephone contact information should we wish to further clarify any issues.

10.3 Telephone Technical Support

Telephone support is available at our head office telephone number Aus: (+61) 3 9775 0505 during Eastern Australian business hours (9am-5pm).

10.4 Contacting the Service Department

The Service department may be contacted by e-mail to service@trio.com.au, or by telephone during Eastern Australian business hours.



TRIO DATACOM GROUP

41 Aster Avenue
Carrum Downs VIC
Australia 3201

T +613 9775 0505
F +613 9775 0606

E support@trio.com.au

www.trio.com.au

Innovative and sophisticated
digital communications

designs products and solutions

Issue 2: December 2002

Information subject to change without notice.
© Copyright 2002 Trio DataCom Pty Ltd. All rights reserved.