

TVIEW+ Programming Screen

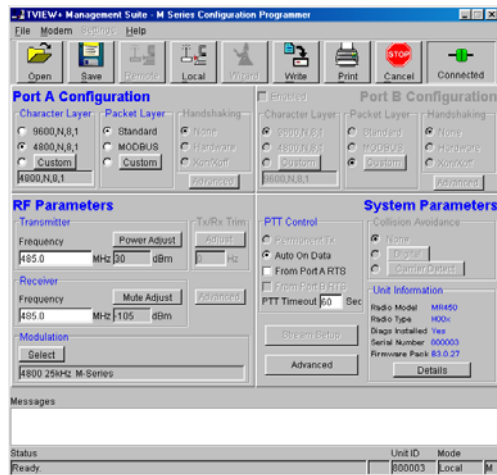

Optimising the Antenna RX signal

Once the unit is operational, it is important to optimise the antenna tuning.

In the case of a directional antenna, it will be necessary to align the antenna for the best received signal.

This can be done by using the (0-5Vdc) output on Pin 9 of the Port to indicate signal strength (RSSI).

This voltage can be converted to dBm using the chart below.

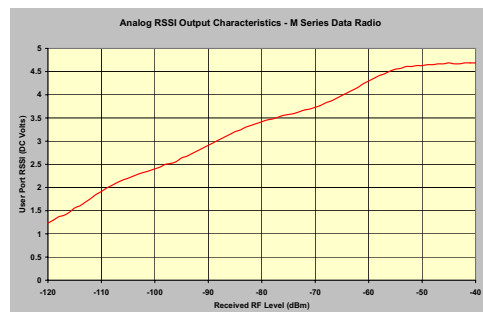
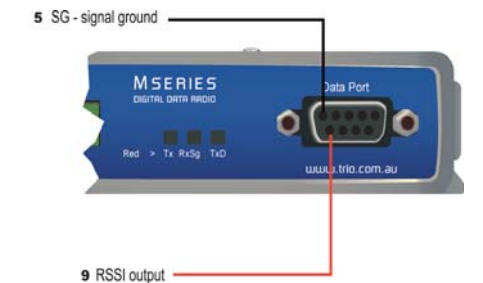

LED Indicators & Test Outputs

Radio is Powered

If all the LEDs are off, check if power is reaching the radio modem. Successful power-up is indicated by the "PWR" LED indicating a continuous (healthy) GREEN state.

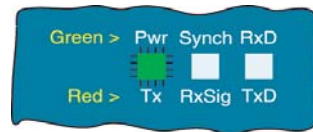

Note that this LED turns RED when the transmitter is active.

Received Signal Indicator

The "Rx/Synch" LED is used to indicate the state of the receiver. If the LED is off, no signal is being received. A RED indication shows that an RF carrier is being received, but no data stream can be decoded. This may indicate the presence of interference or another user on the channel.

A continuous GREEN indication shows that the modem is locked and synchronised to the incoming signal, and has good Bit Error Rate (BER).

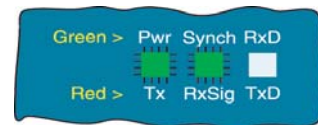
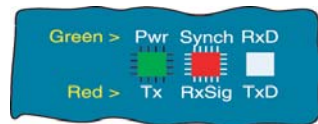

Data Flow "breakout" LEDs

There is also a LED to indicate data flow into and out of the user port. Data into the radio modem is shown as a RED flash, and received data out of the modem is shown as a GREEN flash.

If data is alternately flowing in and out quickly, then the indicator appears orange.

TRIO DATACOM GROUP
 41 Aster Avenue
 Carrum Downs VIC Australia 3201
 T +613 9775 0505
 F +613 9775 0606
 E support@trio.com.au
www.trio.com.au



Information subject to change without notice.
 © Copyright 2004 Trio DataCom Pty Ltd. All rights reserved.

Quick Start Guide MR450 Data Radio

Introduction

Welcome to the MR450 Quick Start Guide. This guide provides step-by-step instructions, with simple explanations to get you up-and-running.



Contents

- Introduction
- Mounting and Environmental
- Communications Ports
- Connecting Antennas and RF Feeders
- Power Supply and Protection
- TVIEW+ Management Suite
- Optimising the Antenna
- LED Indicators & Test outputs

Section

- 1
- 1
- 2
- 3
- 3
- 3
- 4
- 4

Mounting and Environmental Considerations

The MR450 radio comes complete with integrated mounting feet and is attached to a panel or tray by means of screws or bolts, using the hole slots provided.

Note: In high power or high temperature applications, it is desirable to mount the radio with maximum ventilation for the heat sink.

The radio should be mounted in a clean and dry location, protected from water, excessive dust, corrosive fumes, extremes of temperature and direct sunlight. Please allow sufficient passive or active ventilation to ensure the radio modem's heat sink to operate efficiently.

Typical Radio Setup

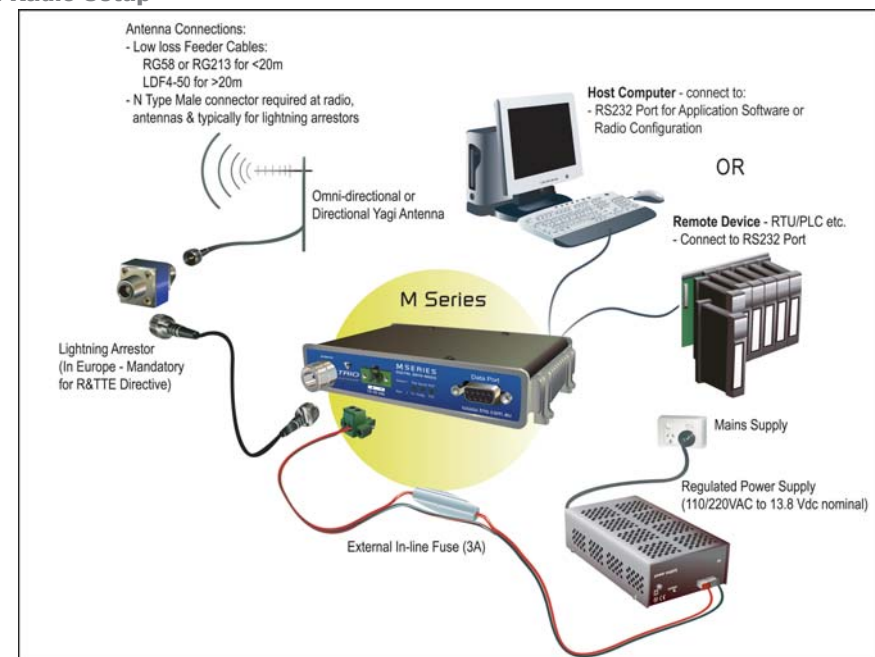

MR450 Connections Layout



Communications Ports

The TVIEW+ M Series User & Configuration / Diagnostics Cable is a DB9 (Male) to two DB9 (Females) patch cable. It provides a connection for user data and configuration / diagnostics. It is intended for RS232 serial communications.

User Interface

The user port is wired as RS232 DCE, configured for no handshaking (3-wire) interface.

Only 3 wires need to be connected between the radio and the application device. See the User Manual for further cable configurations.

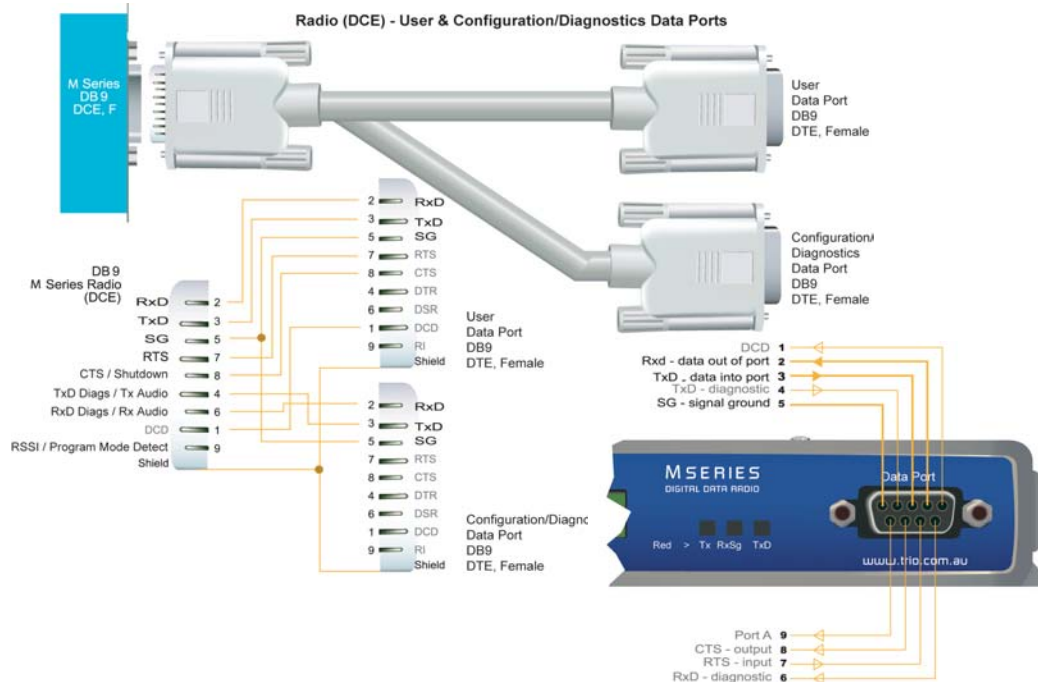
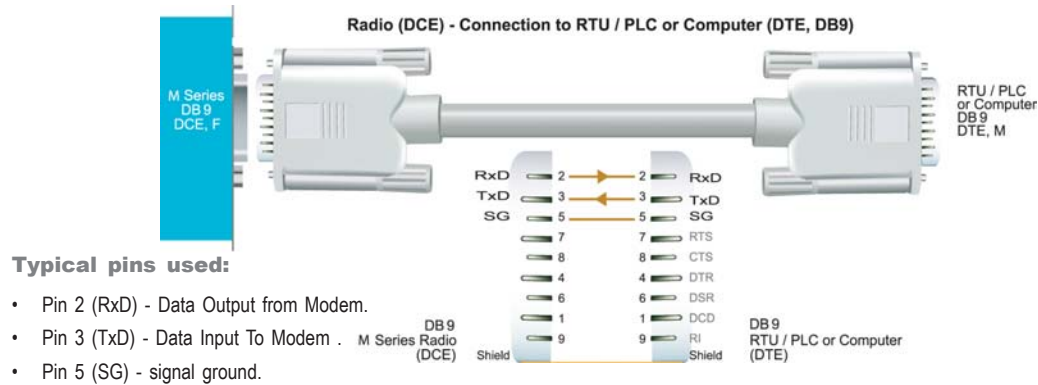

Connecting Antennas and RF Feeders

The RF antenna system should be installed in accordance with the manufacturers notes.

The RF connector used on the M Series radios is an N Type female connector. Always use good quality low loss feeder cable, selected according to the length of the cable run. Ensure all external connections are waterproofed using amalgamating tape.

Preset directional antennas in the required direction using a compass, GPS, or visual alignment and ensure correct polarisation (vertical or horizontal). The RSSI Output (Pin 9) can be used to assist with antenna alignment (see section 4).



Activating the Transmitter

In most systems, the transmitter by default is controlled automatically by the radio when it has data to transmit.

To manually activate the radio transmitter, connect (ie: link) the RTS signal (Pin 7) to Aux (Pin 8).

To operate in this mode, the radio must be configured via the programming software for PTT from RTS.

Caution: Ensure a RF load is present BEFORE transmitting.

Warning - RF Exposure (FCC/IC)

The radio equipment described in this user manual emits low level radio frequency energy. Professional installation is required. The concentrated energy may pose a health hazard depending on the type of antenna used.

This device is intended for FIXED installation conditions. DO NOT allow people to come within 2 metres (6.6 feet) of non-directional antennas and 6 metres (20 feet) from the front of directional antennas when the transmitter is operating.

More information is available from www.fcc.gov/oet/info/documents/bulletins

Power Supply Requirements

The M Series radio modem is designed and calibrated to operate from a filtered 13.8Vdc regulated supply, but will operate from a 10-16Vdc range. See the User Manual for more details on power supply requirements.

Caution: There is **NO** internal replaceable fuse and therefore an external fuse **MUST** be fitted as shown in diagram below (MR450: 3 amp slo-blow fuse, EB450: 5 amp fast-blow fuse, EH450 Controller 1 amp slo-blow fuse).

The radio is designed to self protect, and will blow the external fuse if the voltage exceeds 16Vdc, or if reverse polarity is applied.

The radio modem can also be damaged if there is any potential difference between the chassis-ground, RS232 signal ground, power (-) input, or antenna coaxial shield. Before connecting any wiring, ensure all components are earthed to a common ground point (please pay particular attention to 24V PLC power systems where converters are used).

Connect the antenna and RS 232 plugs BEFORE applying power to the unit.

Lastly, before inserting the power plug, please **re-check** that the polarity and voltage on the power plug is correct using a multimeter. Failure to use an external fuse will result in damage to the radio which will void the warranty.

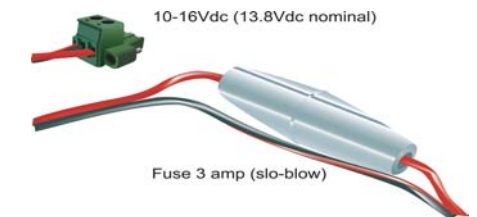

TVIEW+ Management Suite - Radio Configuration

This TVIEW+ Management Suite provides a facility for local radio configuration and diagnostics.

Example: Configuration session -

- 1 Attach the TVIEW+M Series cable between the radio Data Port A and the PC serial port. Ensure the Configuration/Diagnostics plug is connected to the PC serial port and NOT the User Data plug.
- 2 Launch TVIEW+ & Select "Programmer"
- 3 Select "Read" the radio
- 4 Change the configuration as required
- 5 Select "Write" the parameters back to the radio

Refer to the User Manual for detailed operation of advanced features.