

Trio Q Data Radio

User Manual



Contents

Part A – Preface	3	Part G– Quick Start Guide	91
Safety Information	3	Step-by-Step Point to Point Setup	91
Revision History	6	QH Hot Standby Quick Start Guide	95
Important Information	6	Step-by-Step eDiags Setup	98
Compliance Information	7	System Topology Configuration	99
Part B – Feature Overview	8	Router Mode	104
Introduction	8	Network Address Translation (NAT)	108
Features and Benefits	9	Virtual LAN (VLAN)	111
Q Data Radio Range	10	Serial and MODBUS	115
Part C – System Topologies & Operating Modes	12	Single Frequency (Simplex) Mode	120
System Topologies	12	E-Series Emulation Mode	122
Operating Modes	17	Part H – Advanced	124
Part D – Feature Detail	19	Connectivity	124
Hardware	19	Ease of Use	132
Efficiency and Bandwidth	21	Security	155
Connectivity	32	Part I – Installation & Commissioning	158
Ease of Use	35	Optimising the Antenna for Rx Signal	160
Security	42	Commissioning	161
Part E – Radio Planning and Design	44	Part J – Firmware Updating and Maintenance	162
Radio Path analysis	44	Firmware Updating	162
BER & Fade Margin	46	Global Firmware Updating	164
Radio Accessories	47	Fuse Replacement - QR	171
Part F – Quick Reference Guide	50	Part K – Open Source License Acknowledgements	172
Introduction	50	Part L – Support Options	173
Half Duplex Radio - QR150	50		
Half Duplex Radio - QR450	57		
Full Duplex Radio - QB	64		
Hot Standby Half Duplex Radio - QP	69		
Hot Standby Full Duplex Radio - QH	74		
LED indicators	81		
Connecting Antennas	84		
Communication Ports	84		
Activating Transmitter	86		
Factory Default	86		
Digital I/O	87		
Connecting to Web User Interface (WUI)	89		
Resolving Ethernet Connection Issues	90		

Part A – Preface

Safety Information

Read these instructions carefully, and look at the equipment to become familiar with the device before trying to install, operate, or maintain it. The following special messages may appear throughout this documentation or on the equipment to warn of potential hazards or to call attention to information that clarifies or simplifies a procedure.



The addition of this symbol to a Danger or Warning safety label indicates that an electrical hazard exists, which will result in personal injury if the instructions are not followed.



This is the safety alert symbol. It is used to alert you to a potential personal injury hazards. Obey all safety messages that follow this symbol to avoid possible injury or death.

⚠ WARNING

WARNING indicates a hazardous situation which, if not avoided, could result in death or serious injury.

⚠ CAUTION

CAUTION indicates a hazardous situation which, if not avoided, could result in minor or moderate injury.

NOTICE

NOTICE is used to address practices not related to physical injury.

Electrical equipment should be installed, operated, serviced, and maintained only by qualified personnel. No responsibility is assumed by Schneider Electric for any consequences arising out of the use of this material.

⚠ WARNING

HAZARD OF BURN

The QR, QB and QP must be installed in a restricted access location.

Failure to follow these instructions can result in death or serious injury.

For the definition of a restricted access location, refer to the ETSI EN 60950 standard.

⚠ WARNING

HAZARD OF THERMAL BURNS

High operating temperature.

- Avoid direct contact with device while in operation.
- Install device in a restricted access location to avoid unintentional contact.

Failure to follow these instructions can result in death or serious injury.

⚠ WARNING

HAZARD OF RADIO FREQUENCY (RF) BURNS

Ensure that a matching load or antenna is attached to the RF port prior to applying power to the device.

Failure to follow these instructions can result in death or serious injury.

⚠ WARNING

HAZARD OF EXPLOSION

Ensure that all connected equipment is grounded to the power source ground termination.

Failure to follow these instructions can result in death or serious injury.

⚠ WARNING

LOSS OF CONTROL

- The designer of any control scheme must consider the potential failure modes of control paths and, for certain critical control functions, provide a means to achieve a safe state during and after a path failure. Examples of critical control functions are emergency stop and over travel stop.
- Separate or redundant control paths must be provided for critical control functions.
- System control paths may include communication links. Consideration must be given to the implications of anticipated transmission delays or failures of the link¹
- Each implementation of equipment utilizing communication links must be individually and thoroughly tested for proper operation before being placed into service.

Failure to follow these instructions can result in death, serious injury, or equipment damage.

¹ For additional information about transmission delays or failures of the link, refer to NEMA ICS 1.1 (latest edition). Safety Guidelines for the Application, Installation, and Maintenance of Solid State Control or its equivalent in your specific country, language, and/or location.

WEEE Regulation (Europe)

This symbol on the product or its packaging indicates that this product must not be disposed of with other waste. Instead, it is your responsibility to dispose



of your waste equipment by handing it over to a designated collection point for the recycling of waste electrical and electronic equipment. The separate collection and recycling of your waste equipment at the time of disposal will help conserve natural resources and help ensure that it is recycled in a manner that protects human health and the environment. For more information about where you can drop off your waste equipment for recycling, contact the dealer from whom you originally purchased the product.

Dieses Symbol auf dem Produkt oder seinem Verpacken zeigt an, daß dieses Produkt nicht mit anderer Vergeudung entledigt werden darf. Stattdessen ist es Ihre Verantwortlichkeit, sich Ihre überschüssige Ausrüstung zu entledigen, indem es rüber sie zu einem gekennzeichneten Ansammlungspunkt für die Abfallverwertung elektrische und elektronische Ausrüstung übergibt. Die unterschiedliche Ansammlung und die Wiederverwertung Ihrer überschüssigen Ausrüstung zu der Zeit der Beseitigung helfen, Naturressourcen zu konservieren und sicherzugehen, daß es in gewissem Sinne aufbereitet wird, daß menschliche Gesundheit und das Klima schützt. Zu mehr Information ungefähr, wo Sie weg von Ihrer überschüssigen Ausrüstung für die Wiederverwertung fallen können, treten Sie bitte mit dem Händler in Verbindung, von dem Sie ursprünglich das Produkt kauften.

Before using this product, read the Safety Information, Compliance information and all recommendations related to the purchased wireless communications equipment found within the Installation and Commissioning section found within the product user manual. The product user manual is available at www.schneider-electric.com

⚠ WARNING

HAZARD OF UNINTENDED EQUIPMENT OPERATION

To help prevent equipment malfunction, take every precaution during installation against incorrectly activating the wireless communications equipment. This equipment is not a functional safety product.

Failure to follow these instructions can result in death or serious injury, and equipment damage.

⚠ WARNING

LOSS OF CONTROL

- The designer of any control scheme must consider the potential failure modes of control paths and, for certain critical control functions, provide a means to achieve a safe state during and after a path failure. Examples of critical control functions are emergency stop and over travel stop.
- Separate or redundant control paths must be provided for critical control functions.
- System control paths may include communication links. Consideration must be given to the implications of anticipated transmission delays or failures of the link¹
- Each implementation of equipment utilizing communication links must be individually and thoroughly tested for proper operation before being placed into service.

Failure to follow these instructions can result in death, serious injury, or equipment damage.

¹ For additional information about transmission delays or failures of the link, refer to NEMA ICS 1.1 (latest edition). Safety Guidelines for the Application, Installation, and Maintenance of Solid State Control or its equivalent in your specific country, language, and/or location.

Environment

This environment is “enclosed”. It can be installed without any specific protection in areas with restricted access and low pollution levels (not exceeding 2), for example; stations or control rooms which have neither machines nor any activity generating metallic dust or other metallic particles. In other environments, it is recommended to follow rules as defined in the user manual. For the definition of a restricted access location, refer to the ETSI EN 60950 standard.

⚠ WARNING

HAZARD OF DEATH OR SERIOUS INJURY

- The QR, QB and QP must be installed in a restricted access location.
- Ensure that the operating temperature (air surrounding equipment) never exceeds 70 °C (158 °F)
- Ensure that all radio equipment is installed with a lightning arrester.
- Ensure that all connected equipment is grounded to the power source ground termination.
- Where an internal fuse is to be replaced, the replacement fuse must be of the specified type and current rating. Refer to fuse replacement instructions within the Product User Manual before servicing.
- Ensure that a matching load or antenna is attached to the RF port prior to applying power to the device.

Failure to follow these instructions can result in death or serious injury.

⚠ WARNING

HAZARD OF DEATH OR SERIOUS INJURY

•RF Exposure - The radio equipment described in the Product User Manual emits low level radio frequency energy. The concentrated energy may pose a health hazard depending on the type of antenna used. To satisfy EU, FCC and Industry Canada requirements a minimum separation distance should be maintained between the antenna of this device and persons during operation as per the table below

Range of Antenna system gains (dBd)	Minimum Separation from Antenna (Meters)	Minimum Separation from Antenna (Feet Decimal)
0 to 4	1.6	5.3
4 to 8	2.6	8.6
8 to 12	4.1	13.5
12 to 16	6.4	21

Failure to follow these instructions can result in death or serious injury.

Wiring

In order to improve the security of the installation, follow the rules below:

NOTICE**HAZARD OF EQUIPMENT DAMAGE**

- The radio modem can be damaged if there is any potential difference between the chassis-ground, RS-232 signal ground, power (-) input, or antenna coaxial shield. Before connecting any wiring, ensure that all components are earthed to a common ground point.
- The QR150, with the Rx antenna port enabled, can be damaged if the isolation between the Tx and Rx antenna is less than 20 dB. Before connecting the QR150 to an antenna system, ensure that the isolation between the Tx and Rx antennas is greater than 20 dB.
- The QB, when operating with the same transmit and receive frequencies, can be damaged if the isolation between the Tx and Rx antenna is less than 47 dB. Before connecting the QB to an antenna system, ensure that the isolation between the Tx and Rx is greater than 47 dB.
- The QP150 type D (part number TBURQP1xx-xxxxxxD), can be damaged if the isolation between the Tx and Rx antenna is less than 20 dB. Before connecting the QP150 to an antenna system, ensure that the isolation between the Tx and Rx is greater than 20 dB.

Failure to follow these instructions can result in equipment damage.

Revision History

Issue: 03-15	- (March 2015)	Alarms and Events
Issue: 05-15	- (May 2015)	Updated Compliance Information.
Issue: 11-15	- (November 2015)	Updates to support new features in firmware release 1.4.0
Issue: 06-16	- (June 2016)	Updates to support new features in firmware release 1.5.0
Issue: 12-16	- (December 2016)	Support for VHF Q variant

Important Information

© Copyright 2016 Trio Datacom Pty Ltd All Rights Reserved

This manual covers the operation of the Q Data Radio range. Specifications described are typical only and are subject to normal manufacturing and service tolerances.

Trio Datacom Pty Ltd reserves the right to modify the equipment, its specification or this manual without prior notification, in the interest of improving performance, reliability or servicing. At the time of publication all data is correct for the operation of the equipment at the voltage and/or temperature referred to. Performance data indicates typical values related to the particular product.

This manual is copyright by Trio Datacom Pty Ltd. All rights reserved. No part of the documentation or the information supplied may be divulged to any third party without the express written permission of Trio Datacom Pty Ltd.

The manual is also proprietary to Trio Datacom Pty Ltd and are supplied for the purposes referred to in the accompanying documentation and must not be used for any other purpose. All such information remains the property of Trio Datacom Pty Ltd and may not be reproduced, copied, stored on or transferred to any other media or used or distributed in any way save for the express purposes for which it is supplied.

Products offered may contain software which is proprietary to Trio Datacom Pty Ltd. However, the offer of supply of these products and services does not include or infer any transfer of ownership of such proprietary information and as such reproduction or reuse without the express permission in writing from Trio Datacom Pty Ltd is forbidden. Permission may be applied for by contacting Trio Datacom Pty Ltd in writing.

Compliance Information

⚠ WARNING

HAZARD TO HEALTH DUE TO RADIO FREQUENCY (RF) EXPOSURE

- The radio equipment described in this user manual emits low level radio frequency energy. The concentrated energy may pose a health hazard depending on the type of antenna used.
- To satisfy EU, FCC and Industry Canada requirements a minimum separation distance should be maintained between the antenna of this device and persons during operation as per the table below.

Range of Antenna system gains (dBd)	Minimum Separation from Antenna (Meters)	Minimum Separation from Antenna (Feet Decimal)
0 to 4	1.6	5.3
4 to 8	2.6	8.6
8 to 12	4.1	13.5
12 to 16	6.4	21

Failure to follow these instructions can result in death or serious injury.

Typical Antenna Installation Exclusion Zone

The diagram below shows the exclusion zone for a typical antenna installation. The details of this typical system are as follows:

- Q Data Radio - 40dBm (10W)
- Antenna - Yagi 14 dBd/16.15 dBi gain
- Lightning Arrestor - 0.5dB loss
- Cable Run - 1.5dB loss

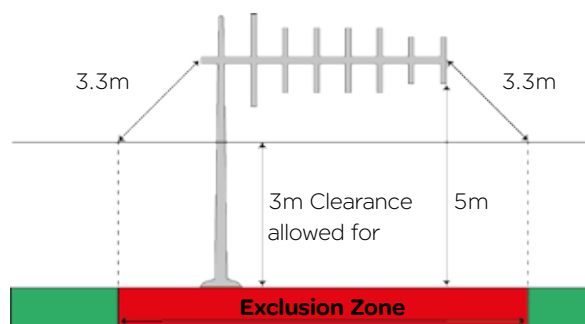

Collocating the QR450 remote (Europe)

The QR450 is a remote radio and should not be collocated with other transmitting equipment.

FCC Compliance

This device complies with part 15 of the FCC rules. Operation is subject to the following two conditions: (1) this device may not cause harmful interference, and (2) this device must accept any interference received, including interference that may cause undesired operation.

The manufacturer is not responsible for any radio or TV interference caused by unauthorised modifications to this equipment. Such modifications could void the user's authority to operate the equipment.

When antennas are co-located on a community (shared) site the correct site engineering must be performed to ensure that RF exposure limits are met.

FCC requirements can be found in 47 CFR 1.1307(b)(3)

Site Grounding

Ensure that the chassis mounting plate, power supply (-) Ground, RTU terminal device, and lightning arrester, are all securely connected to the ground in the building installation or a common ground point to which an earth/ground stake is attached.

R&TTE Directive (Europe)

Applies to models TBURQx4xx-Exxxxxxx

In order to comply with the R&TTE (Radio & Telecommunications Terminal Equipment) directive 1999/5/EC, all radio modem installations must include an external in-line lightning arrester or equivalent device that complies with the following specifications:

- DC Blocking Capability - 1.5kV impulse (Rise Time 10mS, Fall Time 700mS) (Repetition 10 Times) or 1.0kV rms 50Hz sine wave for 1 minute.

Trio Datacom declares that the Q data radio range is in compliance with the essential requirements and other relevant provisions of the Directive 1999/5/EC. Therefore the Trio Datacom Q data radio range is labelled with the following CE-marking.



FCC Compliance (Hot Standby Controller Only)

This equipment has been tested and found to comply with the limits for a Class B digital device, pursuant to Part 15 of the FCC Rules. These limits are designed to provide reasonable protection against harmful interference in a residential installation. This equipment generates, uses, and can radiate radio frequency energy and, if not installed and used in accordance with the instruction, equipment may cause harmful interference to radio communications. However, there is no guarantee that interference will not occur in a particular installation. If this equipment does cause harmful interference to radio or television reception, which can be determined by turning the equipment off and on, the user is encouraged to try to correct the interference by one or more of the following measures:

- Re-orient to relocate the receiving antenna.
- Increase the separation between the equipment and receiver.
- Connect the equipment into an outlet on a circuit different to that which the receiver is connected.
- Consult the dealer or an experienced radio/television technician for assistance.

Industry Canada

This device complies with Industry Canada's license-exempt RSSs. Operation is subject to the following two conditions:

- (1) This device may not cause interference; and
- (2) This device must accept any interference, including interference that may cause undesired operation of the device.

Le présent appareil est conforme aux CNR d'Industrie Canada applicables aux appareils radio exempts de licence. L'exploitation est autorisée aux deux conditions suivantes :

- (1) l'appareil ne doit pas produire de brouillage, et
- (2) l'utilisateur de l'appareil doit accepter tout brouillage radioélectrique subi, même si le brouillage est susceptible d'en compromettre le fonctionnement.

Part B – Feature Overview

Introduction

The Trio Q is a family of data radios designed for wireless transport of Telemetry and Remote SCADA data using the licensed VHF and UHF spectrum.

Trio Q Data Radios are ideal where:

- Total ownership and control of the data radio network is required
- There are long distances to cover
- Public Communications (i.e.: Cellular) is too expensive or unreliable
- Variety of communications delivery is required

Trio Q Data radios are suitable for a wide variety of applications that require the transport of serial or Ethernet protocols, including DNP, MODBUS and IEC, over distances of that up to 50Km (30 miles). Common applications include the monitoring and control of remote assets in the management of:

- Water and Waste Water
- Electrical Distribution and Sub Station automation such as those found in Smart Grids
- The extraction and transportation of Oil & Gas

However, as data transport is transparent to the application, there are virtually no application-specific constraints, other than data throughput and range.

A typical radio system topology permits a central master / control application, like a SCADA Host system for example, to communicate with remotely-situated application equipment such as RTUs or PLCs; using single or dual-frequency radio channels in the 150 MHz VHF band (Qx150) or 450 MHz UHF band (Qx450). A diverse range of system topologies are possible, but in general remote sites communicate directly with the entry point or via repeater stations when direct communication is not possible.

Trio Q Data Radios come in a variety of hardware form factors. The QR450 and QR150 Half-Duplex Radios, are ideal for deployment at remote sites, and operates in simplex or half-duplex modes. Built around a rugged but compact die-cast housing, complete with physical mounting locations, it also has an optional DIN rail mounting kit. Complementing this is the QB Full Duplex Radio, which is ideal for deployment at entry point or repeater sites as it provides high performance full-duplex operation in a 1RU 19" rack form factor. Where redundancy is of value, there are also Hot Standby variants of both the full and half duplex radios.

Over-the-air data speeds are now four times faster than those found in existing licensed data radio systems. Additionally, the radio system can dynamically change its speed during a signal fade or rain storm, enhancing reliable operation, even at the fastest speeds. Combined with features like IP routing and automatic retries, together with advances in collision avoidance, Trio Q provides the ideal platform for building a scalable, easy-to-use, licensed data radio system, where users can greatly increase the number of remote sites per system, and the amount of data transported over the network. Trio Q data radios operate between 135 to 175 MHz and 400 to 518MHz, are approved for use by ETSI & ACMA, are software-configurable for 12.5kHz or 25kHz channels, and up to 10W of Transmit power even at the fastest speed.

There are two Ethernet and two serial ports, that operate in either a Layer-2 Ethernet or Layer-3 IP routing mode. For serial data, both RS-232 and RS-485 is supported using embedded terminal servers, secured by 256-bit AES encryption. Diagnostics and Configuration are performed via web server, Telnet/SSH or serial console, and built in wizards take out the guess work. SNMP traps can provide real time alarm detection of parameters and Integration into ClearSCADA is painless with library templates .

In summary, Trio Q Data radios offer enhanced flexibility, security and reliability, even in harsh, remote environments. They provide an ideal foundation on which to build a data radio system that is scalable, has extended reach, and is virtually future-proof, to help you protect the value of your investment.

Features and Benefits

Common Features – QR | QB | QP | QH

Radio

- VHF Frequency Band Operation: 135...175 MHz
- UHF Frequency Band Operation : 400...450 MHz and 450...518 MHz
- 12.5kHz and 25kHz channel operation in one radio model
- User configurable transmitter output power up to 10 Watts
- Coverage of common international frequency bands
- Designed to meet international FCC & ETSI radio regulatory requirements
- VSWR and over temperature protection
- Operation over full -40...70°C (-40...158°F) ambient temperature range
- Automatic frequency offset compensation for years of service/calibration free operation

Ethernet

- Transport of Ethernet based protocols (including UDP, TCP, DHCP, ARP, ICMP, STP, IGMP, SNMP & TFTP)
- Layer-2 Ethernet Bridge Mode & Layer-3 IP Router mode
- VLAN capability (Bridge mode)
- Maximum narrowband channel utilisation with smart peer-to-peer repeating, broadcast filtering and data compression
- SNMP access to radio diagnostics parameters (including alarm detection and traps)
- Legacy RS-232/RS-485 serial support via embedded terminal servers (UDP/TCP) and MODBUS/TCP gateway
- Configuration via embedded HTTP, HTTPS web interface and/or Telnet/SSH/Serial console
- Local and (one to N) broadcast firmware upgrades
- Embedded NTP Time Server (NTP Client / Server / Client-Server / Manual modes)

Modem

- Dynamic Speed Selection: QoS/RSSI based automatic speed selection (or fixed mode)
- RF Data Rates: Up to 32kbps in a 12.5kHz ETSI Channel & 56kbps in a 25kHz Channel
- Advanced Digital dynamic supervisory collision avoidance system

Security

- Support for 256-bit AES encryption#
- Password protected HTTP and HTTPS configuration/diagnostics management interface
- Password protected Telnet, SSH and Serial console interface
- User administration for radio access

Diagnostics

- Compatible with the Trio TVIEW+ Diagnostics Network Management Software
- Embedded error rate testing facilities
- Diagnostics parameters available for Tx Power, RSSI, DC Supply Volts, Frequency Offset, Temperature and VSWR
- In-build event logging facility

Approvals

- Europe (ETSI): ETSI EN 300 113, EN 301 489, EN 60950
- United States (FCC): FCC Part 15, Part 90
- Canada (IC): IC RS119, ICES-001
- Australia (ACMA): ACMA AS4295-1995 (Data)

#: Export and import restrictions may apply.

Q Data Radio Range

QR450 - UHF Half Duplex Radio

The QR450 Half Duplex Radio is ideal for remote applications as it has a smaller form factor, allowing the product to be installed in space-restricted cabinets/enclosures. The QR450 can also be used as an Entry Point (Base/Master Station) or repeater for systems with a small number of remotes where the transmitter duty cycle is low.

Features of the QR450 include:

- Simplex or Half duplex operation
- Small form factor, rugged die cast housing
115 x 34 x 164 mm (4.52 x 1.33 x 6.45 in.)
- 10...30 Vdc supply voltage.
- DIN Rail Mounting Kit Option
(TBUMDIN-KIT-TYPEA)
- Suitable for use in Class I, Division 2, Groups
A, B, C & D hazardous locations



UHF - Half Duplex Radio

QR150 - VHF Half Duplex Radio

The QR150 Half Duplex Radio is ideal for remote applications as it has a smaller form factor, allowing the product to be installed in space-restricted cabinets/enclosures. The QR150 can also be used as an Entry Point (Base/Master Station) or repeater for systems with a small number of remotes where the transmitter duty cycle is low.

Features of the QR150 include:

- Simplex or Half duplex operation
- Small form factor, rugged die cast housing
115 x 56 x 164 mm (4.52 x 2.2 x 6.45 in.)
- 10...30 Vdc supply voltage.
- DIN Rail Mounting Kit Option
(TBUMDIN-KIT-TYPEA)
- Suitable for use in Class I, Division 2, Groups
A, B, C & D hazardous locations



VHF - Half Duplex Radio

QB150 and QB450 - Full Duplex Radio

Complementing the QR half duplex remote radios, is the QB full duplex radio, ideal for deployment at base & repeater sites in systems using dual frequency operation. In high duty cycle applications, the QB delivers maximum rated transmitter power in ambient temperatures up to 70°C (158°F). Where 1+1 hot standby redundancy is required, the half duplex QP and the full duplex QH are available.

Features of the QB include:

- Full Duplex operation (100% duty cycle)
- 19" 1RU rack mount
- Digital Inputs & Outputs



Full Duplex Base Radio

QP150 and QP450 - Hot Standby Half Duplex Radio

The QP half duplex radio is ideal for deployment at base & repeater sites in systems using dual frequency (half duplex) or single frequency (simplex) operation, where it will only be required to transmit OR receive. In high duty cycle applications, the QP delivers maximum rated transmitter power in ambient temperatures up to 70°C (158°F).

The features of the QP include:

- Simplex or Half duplex operation
- Duplicated redundant transceiver configuration
- Automatic change-over
- 1.9" 1RU rack mount
- Digital Inputs & Outputs



Half Duplex Hot Standby Base Radio

QH150 and QH450 - Hot Standby Full Duplex Radio

Complimenting the QR half duplex remote radios, is the QH full duplex radio kit, ideal for deployment at base & repeater sites in systems using dual frequency operation. In high duty cycle applications, the QH delivers maximum rated transmitter power in ambient temperatures up to 70°C (158°F). Where 1+1 hot standby redundancy is not required, the full duplex QB base/repeater station is available.

The features of the QH include:

- Full Duplex operation (100% duty cycle)
- Ethernet link monitoring and shared IP address provides smart Ethernet redundancy
- Remote monitoring, control and changeover of duplicated base/repeater stations
- Hot-swappable modular 1.9" rack mount transceiver configuration (3 RU total)
- Automatic changeover upon alarm detection of transmitter, receiver, data alarm detection, power supply and data connectivity.
- Digital Inputs & Outputs
- Hot Standby Controller power supply
 - 11...14 Vdc (from output of QBs)
 - Max Current: 800mA



Full Duplex Hot Standby Base Radio

Part C – System Topologies & Operating Modes

System Topologies

Introduction

Fundamental to understanding the use of the Q data radio range in your system is the need for a basic understanding of the different types of radio system topologies and system topology functions.

System Topologies:

Point to Point (PTP):

- A system topology with two radios, one Entry Point and one Remote

Point to Multipoint (PTMP):

- A system topology with three or more radios, one Entry Point that directly communicates to two or more Remotes.

Point to Multipoint via a Repeater (PTMP/R):

- A system topology with three or more radios, one Entry Point that communicates via a repeater to two or more Remotes.

Point to Multipoint via multiple Repeaters:

- A system topology with four or more radios, one Entry Point that communicates via multiple cascaded repeaters to one or more Remotes.

Multipoint to multipoint (MPTMP):

- A system topology with one Entry Point and one or more remotes, and no repeaters, where remotes can talk directly to the Entry Point or to each other.
- Only works with Simplex frequencies.

System Topology Functions:

Entry Point:

- The radio where user data enters the systems. Typically connected (directly or indirectly) to the Master RTU or SCADA Host.

Repeater:

- A radio which repeats data from an Entry point to Remote, or Remote to Remote, or Repeater to Repeater.

Remote:

- A radio which is the endpoint or perimeter of the system topology.

Each type of network is described in the following diagrams.

Point-to-Point (PTP)

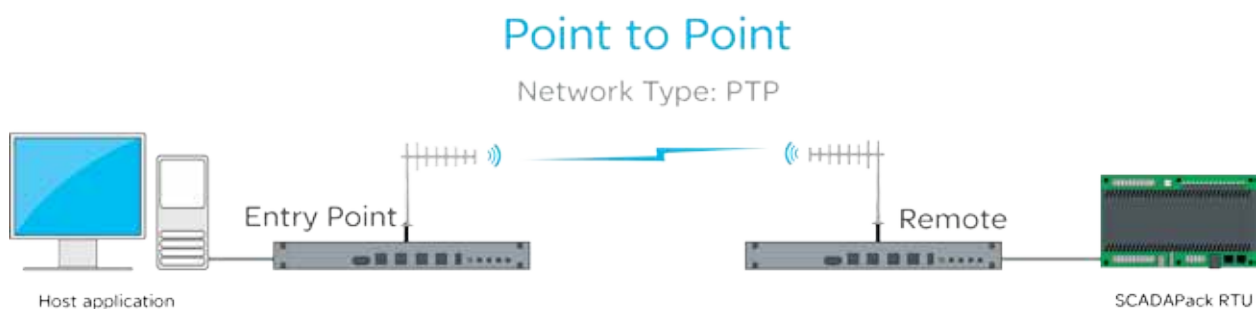

A Point to Point (PTP) network has one Entry Point and one Remote radio. When full duplex radios are installed, full data throughput can be achieved in each direction. Alternatively, half-duplex radios can also be implemented although collision avoidance should be enabled.

Full Duplex radios have the advantage that they simulate a cable connection with respect to the connected devices. Even if one device transmits continuously it will not block the other device from sending data. This is useful for applications that expect full duplex communications or that are not designated to be radio modem friendly.

Point to Multipoint (PTMP)

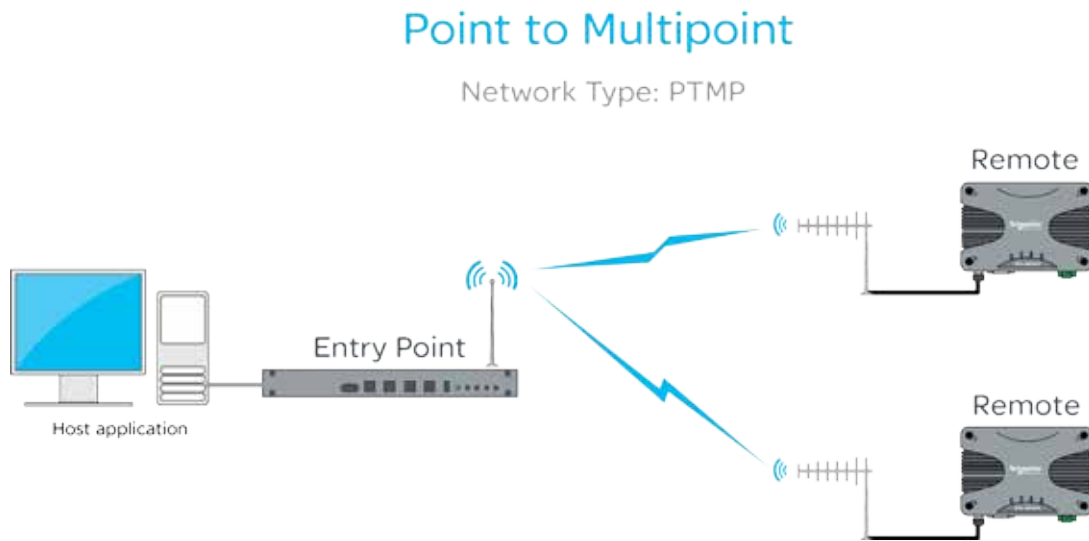

A Point to Multipoint (PTMP) network is normally chosen when a central site (i.e.: The HOST application) needs to communicate with multiple REMOTE sites.

Point to Multipoint (PTMP) operation requires the Entry Point site to have adequate RF coverage of all Remote sites. A PTMP offers optimal available bandwidth and data latency when multiple remote sites are required.

In a multiple access radio system (MAS), communication occurs from a common site (the Entry Point) to all others, either using a half duplex or simplex radio channel. In addition, remote sites can communicate to each for peer to peer messaging, via the Entry Point.

For two frequency systems, to facilitate efficient data communication and support features such as digital collision avoidance, it is recommended that the Entry Point be a full duplex radio (QB/QH).

Utilising a half duplex Entry Point radio is possible, however some features may not be available and system performance may be lower when compared to using a full duplex entry point.

In most applications, this type of system topology is more efficient than other topologies.

Point to Multipoint via Repeater (PTMP via Rep)

Point to Multipoint via Repeater

Network Type: PTMP/R

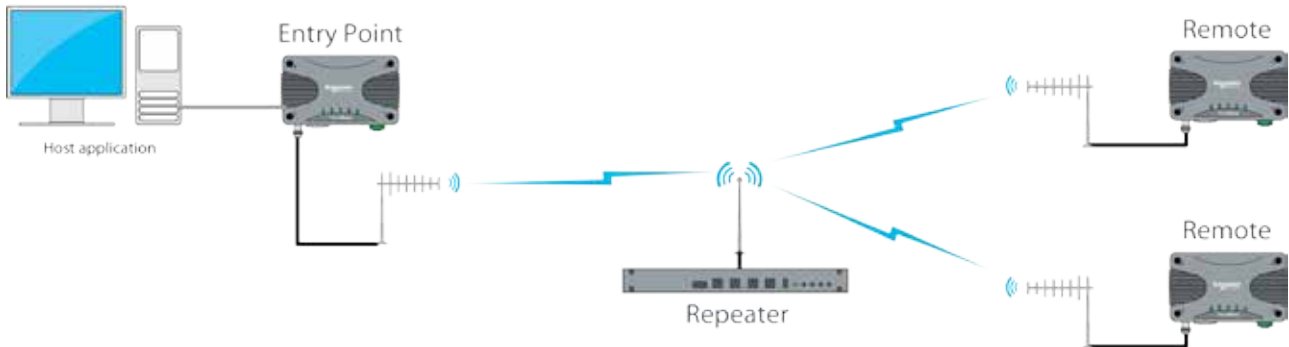

A Point to Multipoint via repeater (PTMP/R) network is a variation of the Point To Multipoint (PTMP) network. It is normally chosen when the site where the Host application (i.e.: Entry Point) does not have adequate RF coverage of Remote sites in the network.

This network topology consists of a radio configured as a Repeater (typically full duplex), an entry point radio and a number of remotes. The repeater can be configured to repeat data based on either IP layer 2 (Bridge mode), or IP layer 3 (Router mode) rules.

The repeater should be located at a site with adequate RF coverage to each of the remotes.

For two frequency systems, to facilitate efficient data communication and support features such as digital collision avoidance, it is recommended that the Repeater be a full duplex radio (QB/QH).

Utilising a half duplex Entry Point radio is possible, however some features may not be available and system performance may be lower when compared to using a full duplex entry point.

Other aspects of the Point to Multipoint network apply to this network topology.

Point to Multipoint via Multiple Repeaters (PTMP via multiple Repts)

Point to Multipoint via Multiple Repeaters

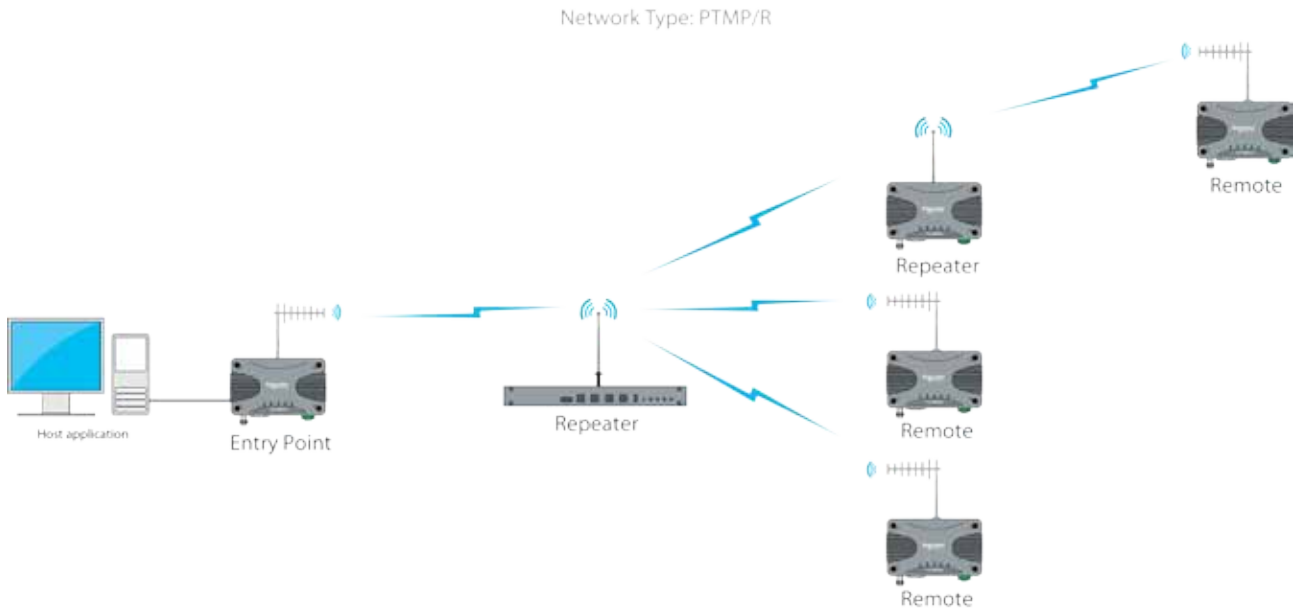

A PTMP via multiple repeaters system is a variation of the PTMP/R system. It is normally chosen when the site where the Host application (i.e.: Entry Point) together with the first repeater have inadequate RF coverage of remote sites in the network.

In this system topology, there are multiple radios configured as repeaters. The PTMP/R with multiple repeater system topology is only possible when using IP routing mode. Each repeater is configured to repeat traffic based on destination IP address.

The repeaters should be located at sites with adequate RF coverage for the remote sites. For two frequency systems, to facilitate efficient data communication and support features such as the collision avoidance mechanism, it is recommended that the first Repeater be a full duplex radio (QB/QH).

Utilizing a half duplex Repeater is possible, however some features may not be available and system performance may be lower when compared to using a full duplex entry point.

Other aspects of the Point to Multipoint network apply to this network topology.

Flat Multipoint to Multipoint (MPTMP) - Simplex

Multipoint to Multipoint (Simplex)

Network Type: MPTMP

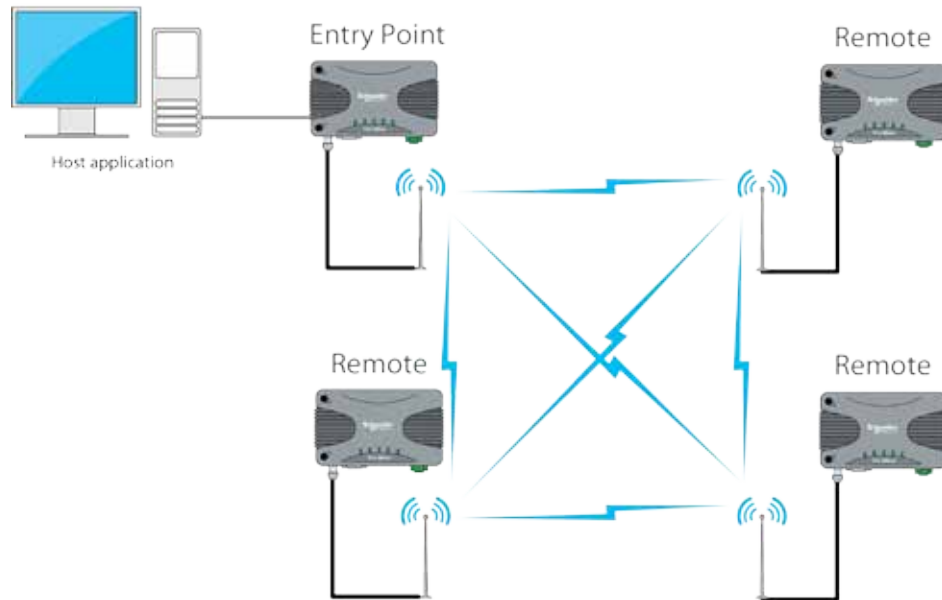

A Multipoint to Multipoint network is a variation of the Point To Multipoint network. It is primarily used when the system requirement is for each site to be able to communicate directly with every other site. This requires every site to have adequate RF line of sight to every other site along with the use of simplex frequencies (Rx & Tx frequencies are the same).

In this system topology, each site typically require the use of an omni directional antenna. This is to provide an even spread of antenna gain to and from each site.

Operating Modes

Introduction

This section assumes the reader has an operational understanding of industrial Ethernet.

A typical Ethernet network consists of a number of IP devices, all which share the requirement of data communication. In order for a pair of devices within an Ethernet based network to communicate with one another, they need to be able to address data to a specific destination (in this case, each other).

MAC Address - MAC addresses identify Ethernet devices on a network when operating at Layer-2. All Ethernet ports in devices have their own unique media access control (MAC) address. There are special MAC addresses used for broadcast and Multicast messages.

IP Address - An IP address is a numerical label assigned to each device (e.g., Radio, RTU, SCADA Host) participating in a computer network that uses the Internet Protocol for communication.

An IP address serves two principal functions:

- Host or network interface identification and
- Location addressing.

Subnet - A subnet is a subdivision of an IP network. It allows a network designer to segment a large IP network into smaller, manageable sub networks. This can assist in the allocation of IP addresses and the management of network bandwidth.

Subnet Mask - Together with the IP address, the subnet mask is used to determine which subnet a device belongs to.

Gateway - A gateway forwards IP messages between devices on different subnets in an IP network. A gateway uses configurable routing rules to determine where to forward an IP message.

Route - A route is a rule that indicates where an IP message needs to be sent in order to get to a specific device on an IP network.

Transparent Bridge Mode

The Q data radios can be configured to operate in a transparent bridge mode. This mode transports all data as layer 2 Ethernet traffic over the radio network. Each radio will behave like a layer 2 Ethernet switch, transparently forwarding traffic, based on rules, dynamically determined from device MAC addresses. Traffic can also be repeated in any one single radio in the network using a peer to peer repeat function (an enable/disable function, typically enabled in repeaters). Each radio requires an IP address and mask to be configured in order for a user to access radio management features (web server/Telnet/diagnostics/etc..). The example below shows a typical PTMP/R topology, with all radios operating in bridge mode.

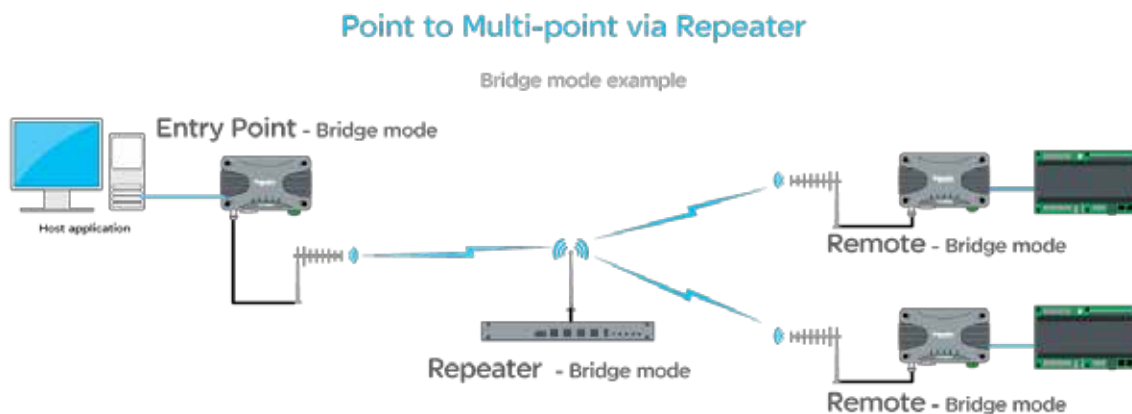

From an IP network perspective, each radio within the topology above, effectively looks like an Ethernet switch. See the example below.

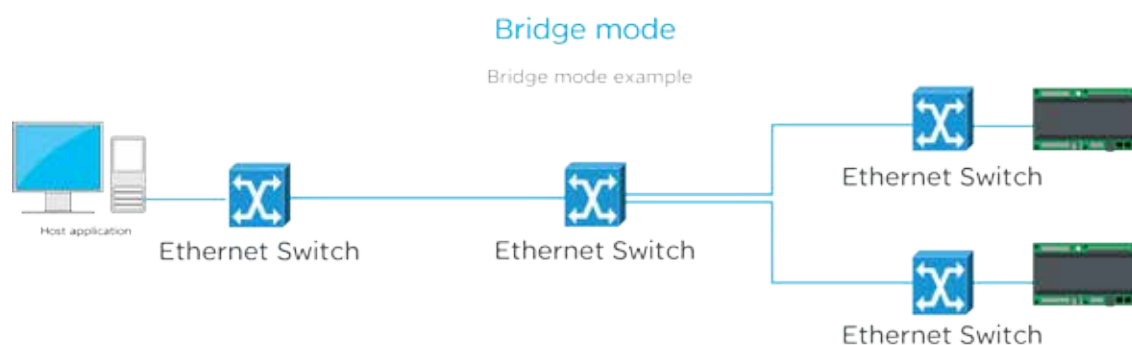

Router Mode

The Q data radios can also be configured to operate in router mode. Router mode provides the radio the ability to route IP data, based on user configurable network routing rules (OSI model layer 3), between devices on different subnets.

The benefits of router mode include:

- Faster poll times
- Higher throughput
- Improved management of IP addresses

Each radio behaves as a network gateway for its corresponding subnet. This allows a network designer to segment a wide area IP network (WAN) into smaller subnets, which minimises the amount of over the air radio traffic. Since each radio behaves as a router, traffic will be routed (and repeated) based on user defined IP routing rules. The example below shows how router mode segments an IP radio network into smaller subnets. Each radio has its own subnet, represented in the example by dashed colored boxes.

Point to Multi-point - Router mode

Router mode example

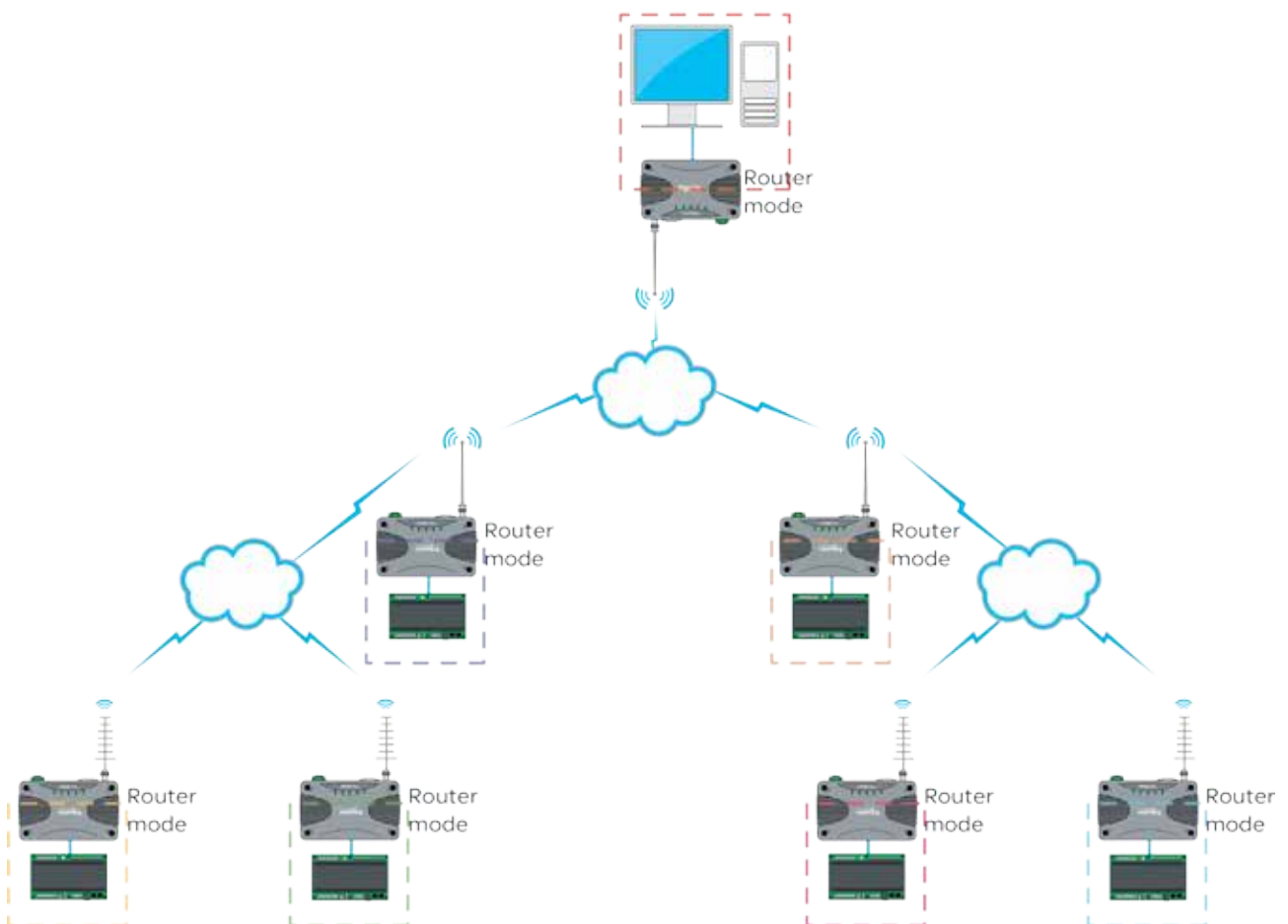

Part D – Feature Detail

Hardware

QR150 - Half Duplex Radio

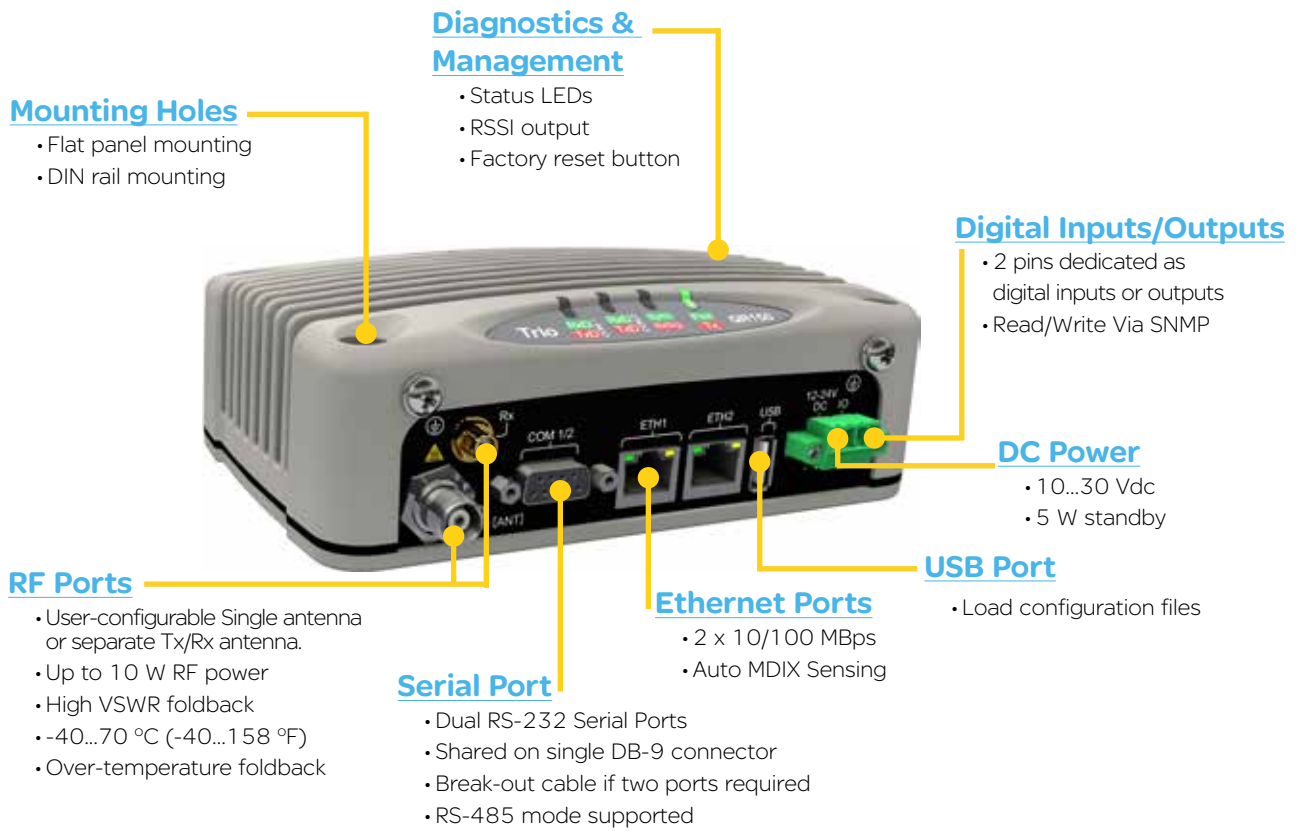

QR450 - Half Duplex Radio

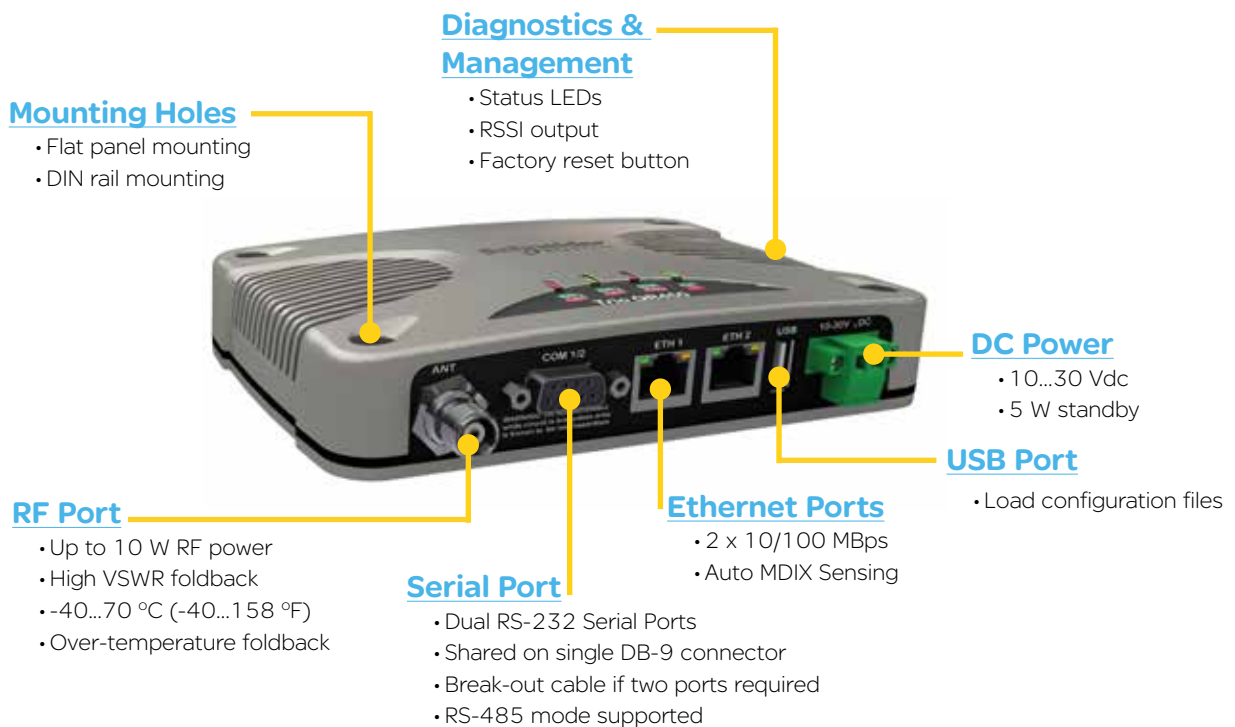

QB150 & QB450 – Full Duplex Radio

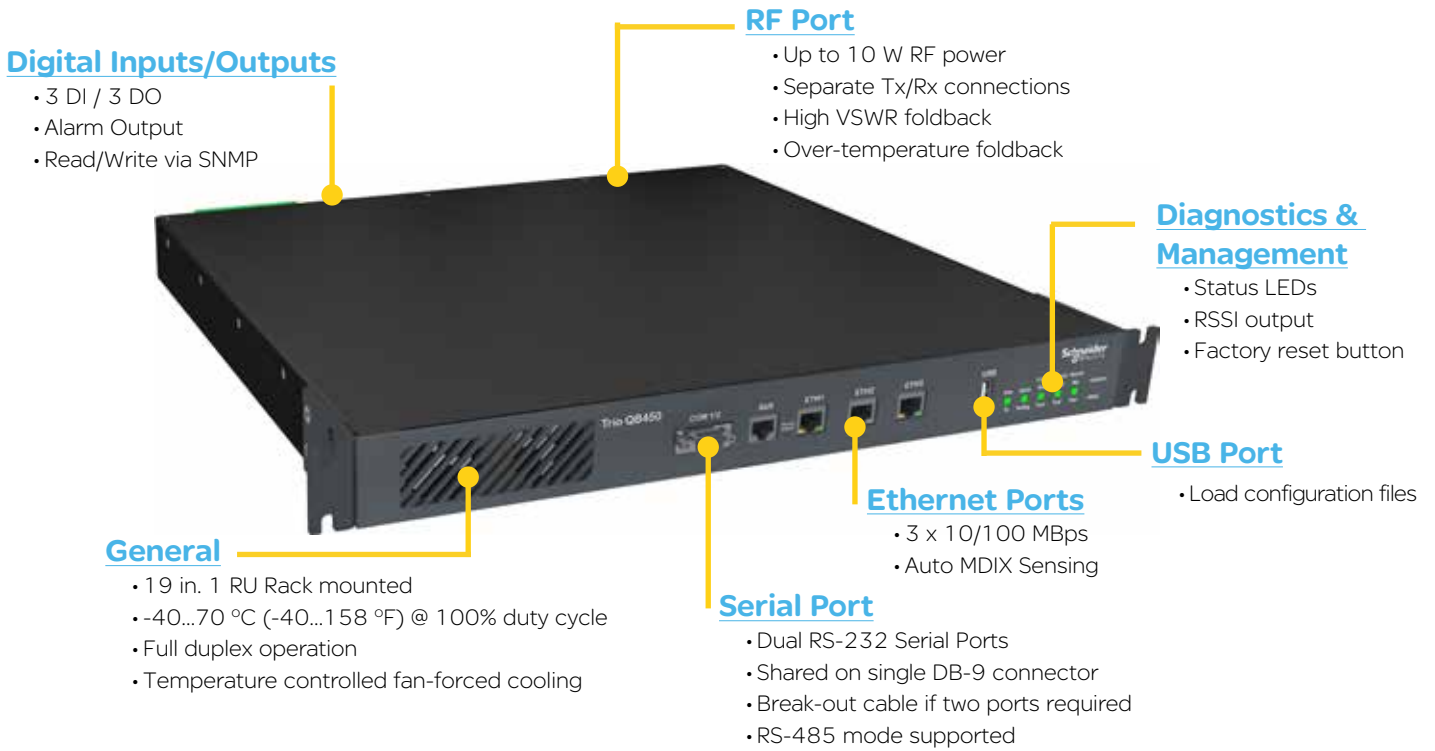

Efficiency and Bandwidth

RF Speeds and Sensitivity

The Trio Q data radios use continuous phase modulation (CPM) which supports up to 10 Watts of transmitter output power, even at the fastest RF data rate.

This avoids the need to compromise on range when operating at the fastest speeds. Two different radio variants and modulation types are available, depending on the regulatory requirements (FCC or ACMA/ETSI).

- TBUROxxx-**E**00xxxxx: 'E' denotes ACMA/ETSI
- TBUROxxx-**F**00xxxxx: 'F' denotes FCC

Contact your local sales representative if you need to confirm the applicable model for your regulatory region.

Regulatory Region	Channel Bandwidth (KHz)	RF Speed (Kbps)	BER threshold (10 ⁻⁶)	
			VHF (150)	UHF (450)
FCC/IC	12.5	8	-113	-113
		16	-111	-110
		24	-108	-107
		32	-100	-100
ACMA/ETSI	12.5	8	-113	-113
		16	-111	-110
		24	-108	-107
		32	-100	-100
	25	14	-109	-111
		28	-107	-109
		42	-105	-106
		56	-98	-99

ARQs

Automatic Repeat reQuests (ARQs): When enabled, ARQs confirm successful reception of data transmitted over the air. Each time a radio (originator) transmits data, the receiving radio replies with an acknowledgement back to the originator, confirming successful reception of the data. If an acknowledgement is not received by the originator within an acceptable time frame, the originator declares the data lost and retransmits the data. The number of retransmit attempts is user configurable (i.e. when ARQ = 2, there will be a maximum of two retransmit attempts per message).

When Ethernet data is not successfully transmitted over a radio network (i.e. due to a data collision), Ethernet devices can interpret this as network congestion, resulting in unnecessary slow down of SCADA polling. ARQs increase the probability of successful transportation of data over the radio link. However, when ARQs are enabled, the capacity of the radio network is reduced, due to the ARQ acknowledgements. As only one device can generate an acknowledgement for received data, ARQs are not applicable to broadcast or multicast traffic

Typical data transaction with ARQ enabled

The example below shows the ARQ behavior between a pair of radios during a typical data transaction.

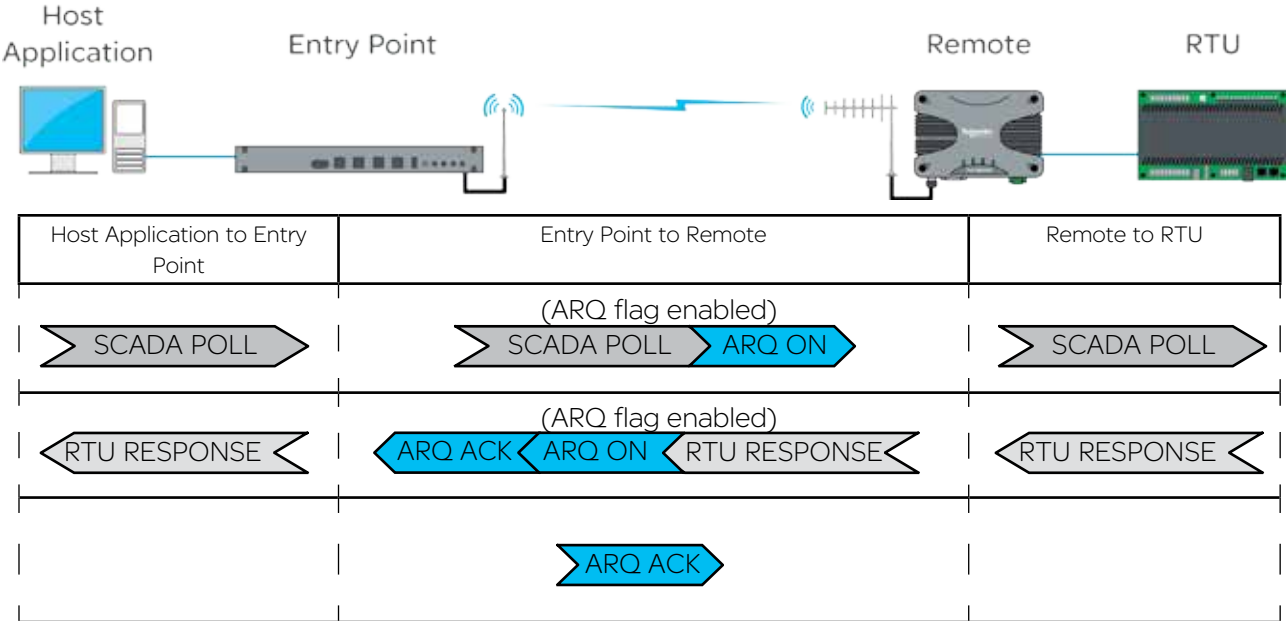

Automatic Retry Example

The example below shows the ARQ behavior between a pair of radios when a packet is lost during a transmission (ARQ =1).

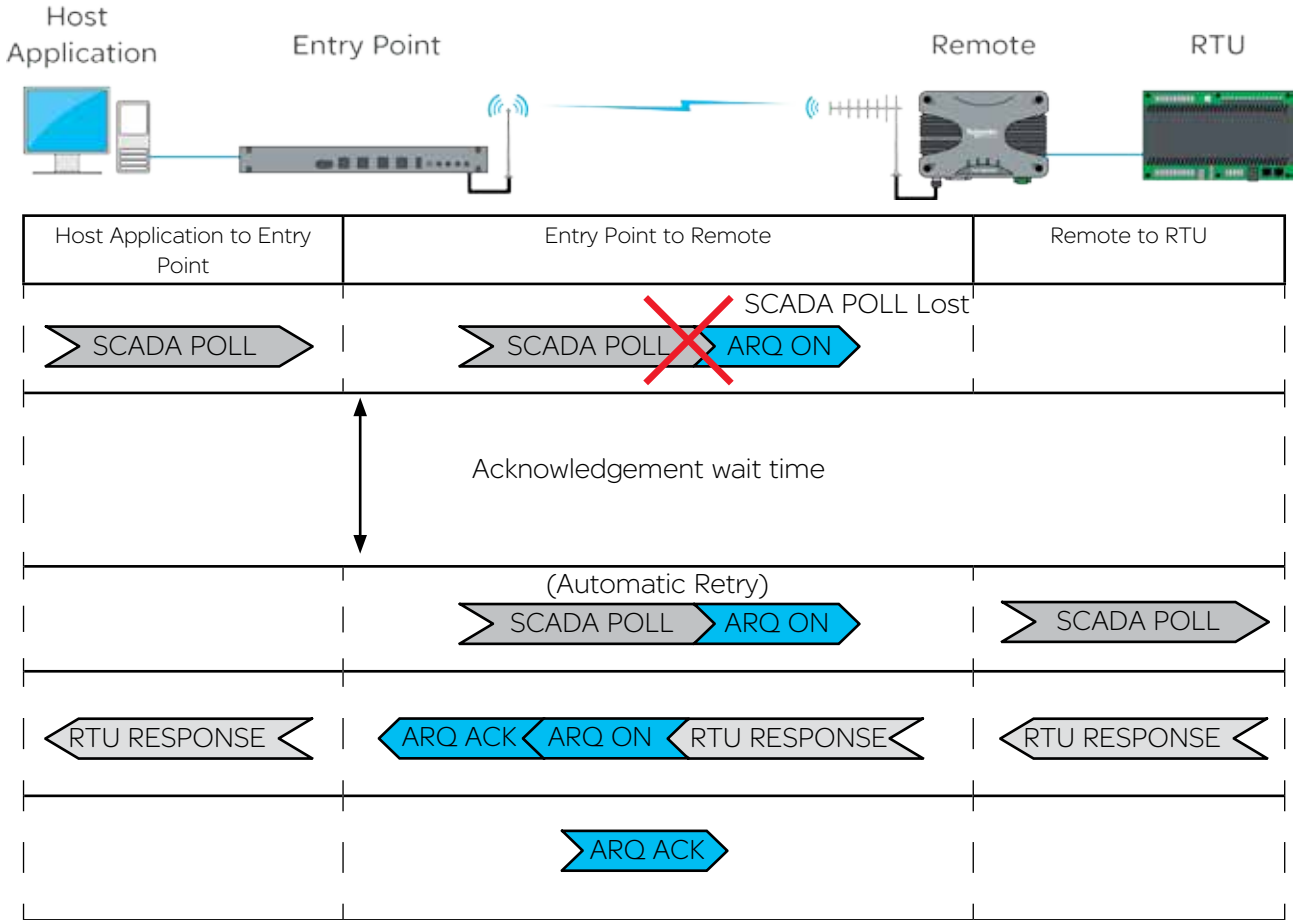

The radio will wait 500ms for an acknowledgement, before sending an automatic retry. It is recommended that the SCADA host poll response time out time is configured to be a minimum of 3 seconds.

Dynamic Speed Selection

Traditional narrow band SCADA data radios achieved wireless communication over long distances by transmitting at low RF data rates (typically 9600bps or less). Modern SCADA systems require faster RF data rates, due to the need to support additional traffic for Ethernet and IP. However, reliable transmission over long distances at faster RF data rates, can be difficult to achieve.

To assist in reliable data transmission over long distances at faster RF data rates, the Trio Q data radios utilise dynamic speed selection. Dynamic speed selection provides the following enhancements:

- Operation at the fastest possible RF speeds
- Measurement of Quality of Service - QoS (success of data delivery to other end) and
- Automatically adjusting to a slower RF speed to improve quality, if QoS is inadequate

Dynamic speed selection is individual for each remote in a point to multipoint (PTMP) system. Should one remote need to operate at a slower RF speed due to limited received RF signal, others will continue to operate at the fastest possible RF speed as dictated by their own received RF signal strength for that specific site.

RF Data Rate vs RF Sensitivity

As stated earlier in this section, Trio Q Data Radios have four different RF speeds for each channel bandwidth selection (12.5kHz or 25kHz). Each RF speed has a corresponding receiver 1×10^{-6} BER (Bit Error Rate) sensitivity. The slower the RF speed, the better RF sensitivity, and therefore the longer the range for a given level of reliability.

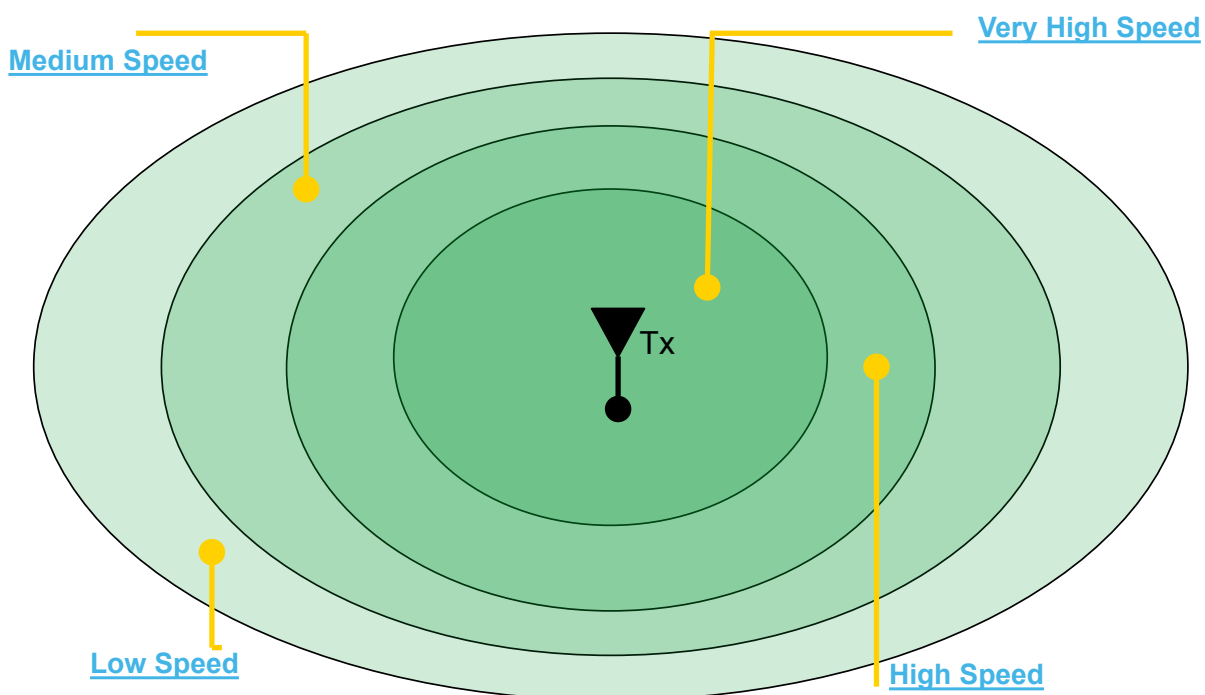

The further away from the master station, the weaker the received signal. Slower RF speeds are required for an acceptable level of reliability.

Consider the example shown in the diagram above. An entry point / base station is located in a fixed position. When communicating with a remote radio, RF energy between the two radios diminishes in strength as the signal propagates over distance.

In a system with out dynamic RF speed selection, the user would need to configure a suitable fixed RF speed, dependent on the signal strength at the remote site. In most applications, a minimum of 20dB fade margin is recommended for reliable operation (due to rain fades, cable degradation, multipath fading, etc). If the remote radio is fixed at a specific RF speed, then in order to maintain a received signal 20dB above the $1E-6$ BER sensitivity (20dB fade margin), the user would need to decrease the RF speed when the receiving radio is further away from the transmitter. This is depicted in the diagram above by the concentric rings showing what RF speed can needs to be selected in order to maintain a 20dB fade margin.

Consider now, in the below example where dynamic RF speed selection is enabled. Now that the receiving radio can adjust its RF speed dynamically, a faster RF speed can be chosen for normal operation. Even though the faster RF speed will not provide 20dB of fade margin, the system is still reliable because dynamic speed selection will drop down in RF speed when a signal fade occurs.

Dynamic Speed - No Obstructions

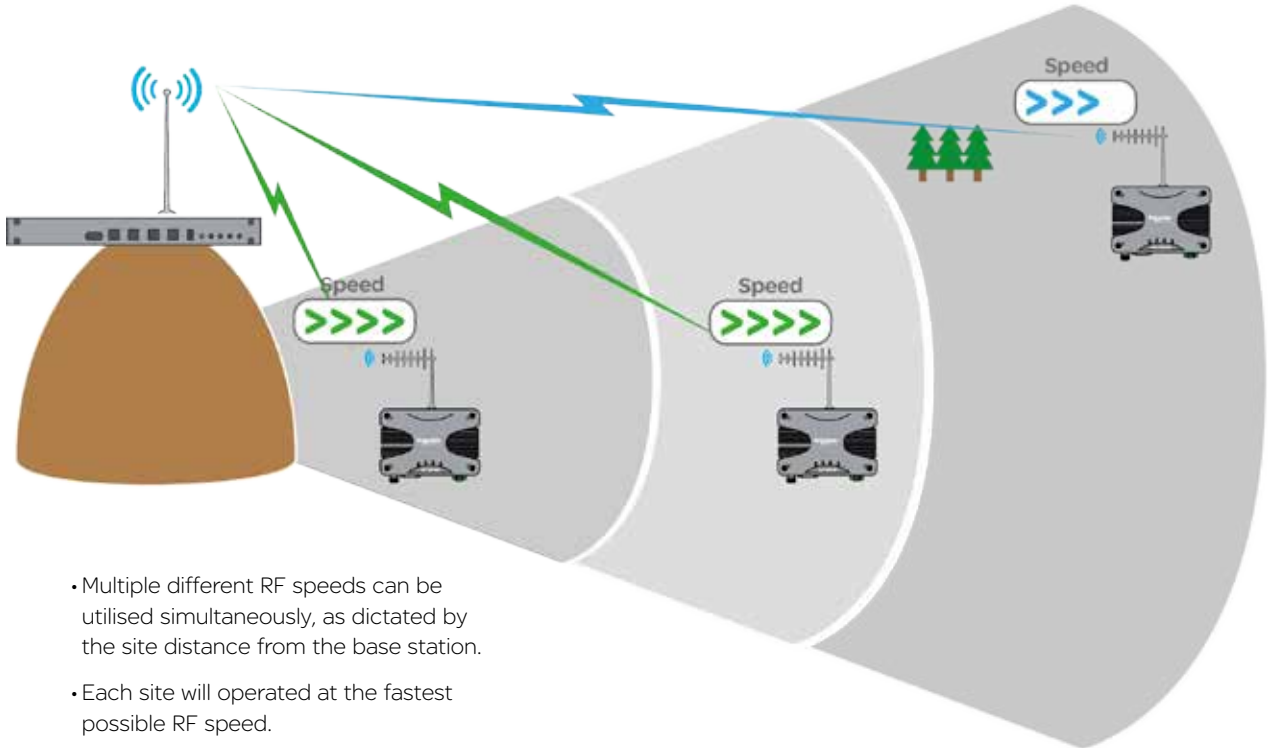

- Multiple different RF speeds can be utilised simultaneously, as dictated by the site distance from the base station.
- Each site will operate at the fastest possible RF speed.

Old Technology - No Obstructions

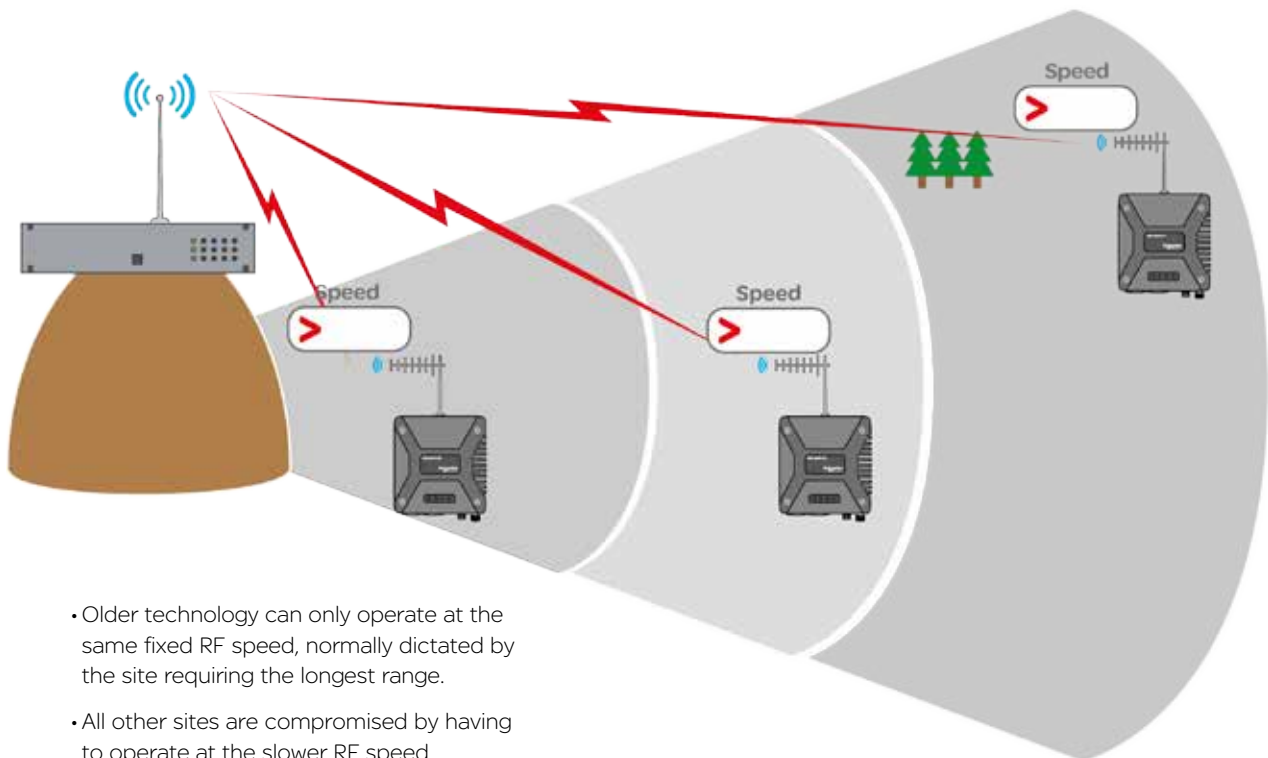

- Older technology can only operate at the same fixed RF speed, normally dictated by the site requiring the longest range.
- All other sites are compromised by having to operate at the slower RF speed

Dynamic speed selection derives QoS from both RSSI (Received Signal Strength) and ARQ performance in order to maintain a radio link operating at the fastest speed possible for the given quality of the link.

Each radio stores a table of destination MAC addresses vs fastest RF speed in a dynamic speed cache, using information learned from previous transactions over the air. In this way, the radio dynamically learns what RF speed should be chosen for a transmission. Should the transmission generate an ARQ, the radio will drop down in RF speed to improve reliability of data delivery.

In the event that radio has not yet learnt the fastest RF speed for a destination MAC, the message will be transmitted out at the slowest RF speed in the given bandwidth, to provide the highest sensitivity, and therefore the highest reliability.

As broadcast and multicast addresses are potentially destined for multiple radios these types messages will always be transmitted at the slowest speed. The following diagrams show how the RF data rate can be influenced by obstructions:

Dynamic Speed - With Obstructions

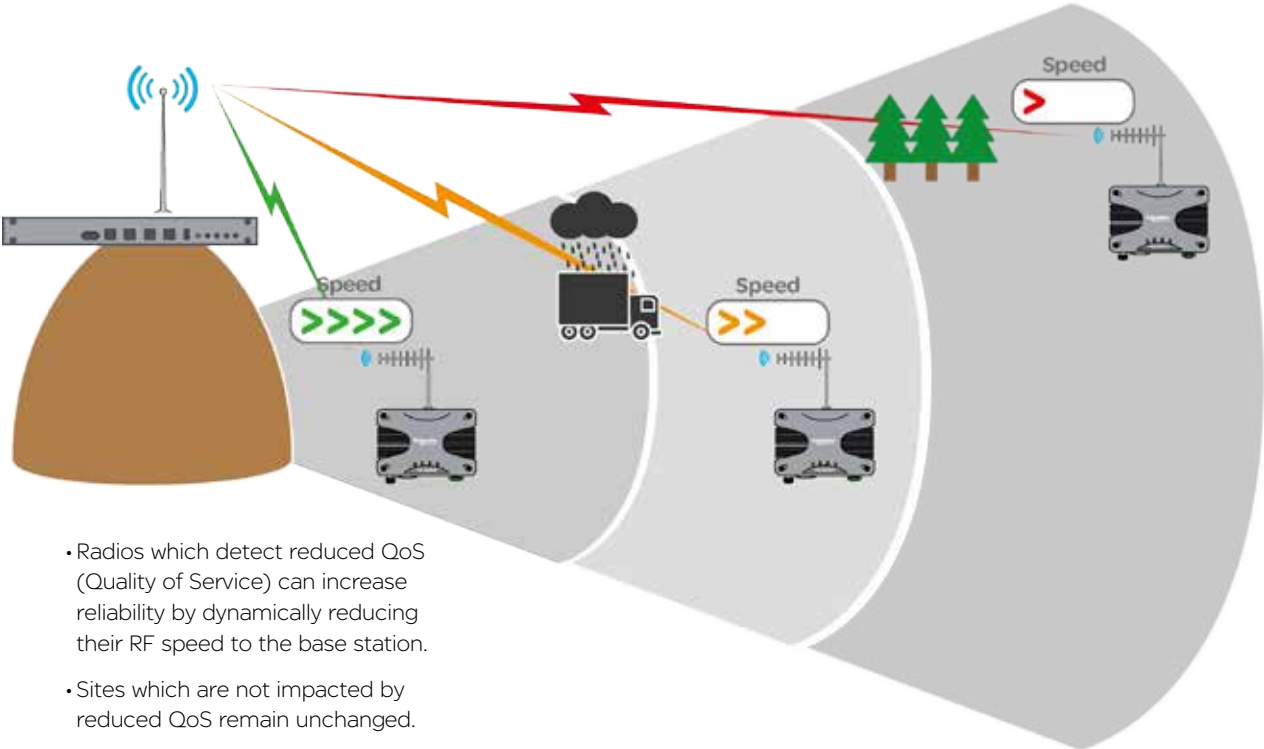

- Radios which detect reduced QoS (Quality of Service) can increase reliability by dynamically reducing their RF speed to the base station.
- Sites which are not impacted by reduced QoS remain unchanged.

Old Technology - With Obstructions

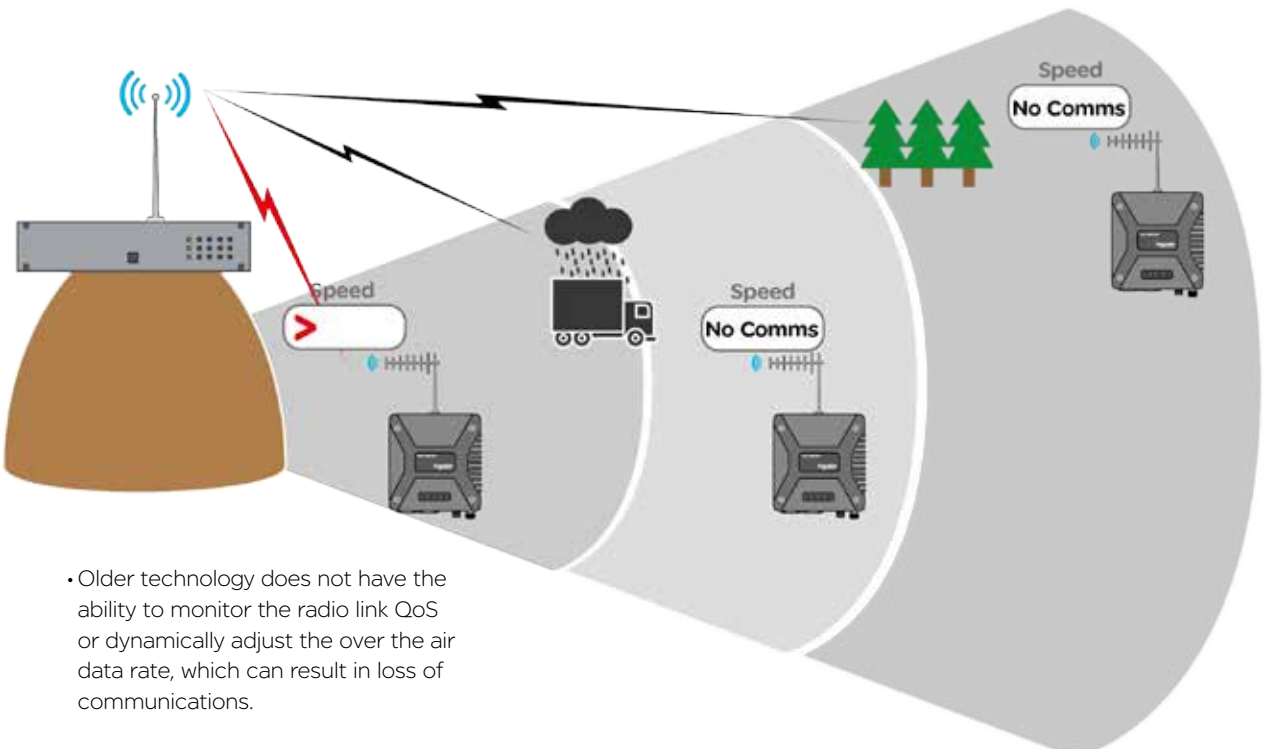

- Older technology does not have the ability to monitor the radio link QoS or dynamically adjust the over the air data rate, which can result in loss of communications.

Dynamic Speed Cache

The dynamic speed cache is used by a radio to record specific external values that are learnt. These values are then used by other processes within the radio (such as dynamic speed and ARQ) to help ensure that optimum performance is achieved over the radio channel.

External values that are learnt are shown in the table below.

Remote Host MAC	Associated Radio Serial Number	RSSI level

Remote Host MAC: The MAC address of a device which is connected to a remote radio.

Associated Radio Serial Number: The Unique ID of a remote radio with which the Remote Host Device/MAC is associated with.

RSSI level: The signal strength received from the radio specified within the associated radio serial number field.

A typical data packet structure is shown below. (For the purposes of this example, the preamble, Ethernet type and CRC fields have been excluded.)



Data packets sent over the air between radios have an additional field appended. An example is shown below.

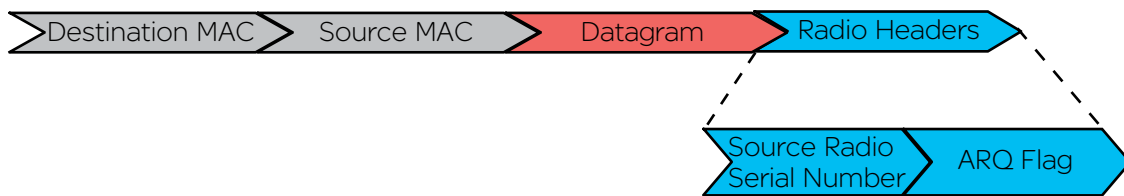

Consider now, in the below example where dynamic RF speed selection is enabled. Now that the receiving radio can adjust its RF speed dynamically, a faster RF speed can be chosen for normal operation. Even though the faster RF speed will not provide 20dB of fade margin, the system is still reliable because dynamic speed selection will drop down in RF speed when a signal fade occurs.

Dynamic speed selection derives QoS from both RSSI (Received Signal Strength) and ARQ performance in order to maintain a radio link operating at the fastest speed possible for the given quality of the link. The two influencing factors are:

Each radio stores a table of destination MAC addresses vs fastest RF speed in a dynamic speed cache, using information learned from previous transactions over the air. In this way, the radio dynamically learns what RF speed should be chosen for a transmission. Should the transmission generate an ARQ, the radio will drop down in RF speed to improve reliability of data delivery.

In the event that radio has not yet learnt the fastest RF speed for a destination MAC, the message will be transmitted out at the slowest RF speed in the given bandwidth, to provide the highest sensitivity, and therefore the highest reliability.

As broadcast and multicast addresses are potentially destined for multiple radios these types messages will always be transmitted at the slowest speed.

E-Series Emulation Mode

The Q data radios can be configured to operate in E-Series emulation mode. This can allow the replacement of existing E-Series radio networks to be upgraded to Q data radio systems at a pace the user defines.

E-Series Emulation Mode can provide:

- A cost effective upgrade to a Q data radio network
- Minimise SCADA connectivity downtime during an upgrade
- A greater subset of features once the radio network is fully upgraded, as E-Series emulation mode is a user configurable feature.

The diagram below shows how an existing E-Series radio system can be progressively upgraded to a Q data radio system by replacing E-Series radios 'One by One' with Q data radios operating in E-Series emulation mode.

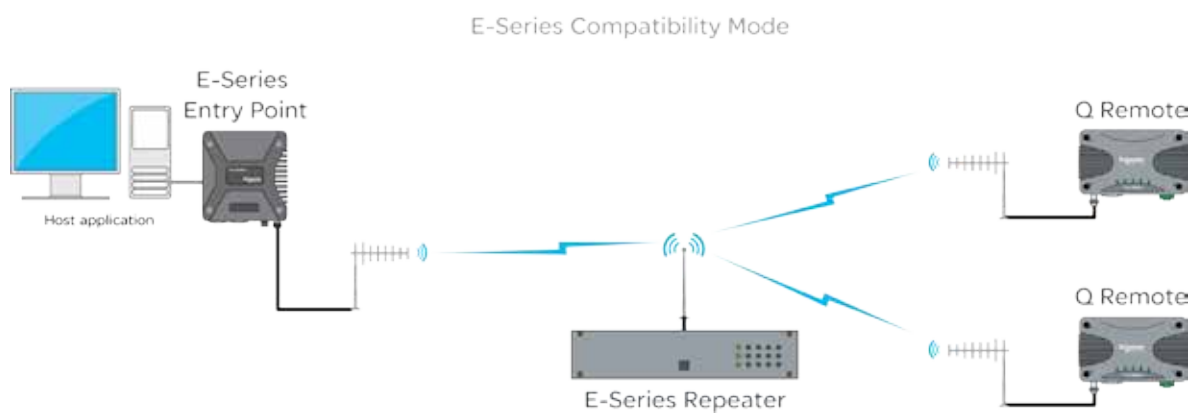

Once all E-Series have been replaced, the Q data radios may be re-configured to operate in Q mode, to provide advanced features and functionalities of the Q data radios.

Collision Avoidance

Introduction

In many SCADA and remote Telemetry applications, there exists the potential for over the air data collisions between radios. This can occur when multiple asynchronous data traffic is present on the radio channel, such as SCADA polling, SCADA exception reports, SNMP traps, pings and ARP requests.

In two frequency systems, collisions may occur on the receive channel of an Entry Point or Repeater radio, due to two or more remotes transmitting simultaneously. If this occurs, the radio will receive a corrupted message from both radios and a re-try will be required. Similarly, in simplex (single frequency) systems, collisions may occur on any receiving radio when two or more radio transmit simultaneously.

In two frequency systems, collision avoidance minimises the chance of collisions by configuring one radio, as the collision avoidance master, which informs remote radios when the master's receive RF channel is busy. Remotes will check whether the master is allowing access to the channel before a transmission occurs. If the channel is free, the remote will transmit. If the channel is busy, the remote will buffer the message and execute a small random delay (in case multiple remotes have data to send), then attempt to access the channel again. By avoiding collisions the SCADA system is able to operate more efficiently, with fewer retries. Similarly, in simplex (single frequency) systems, remote radios can detect when the Entry Point or Repeater radio is transmitting, and wait for it finish, before transmitting itself.

For two frequency systems, there are two different modes of collision avoidance:

- **Carrier Detect** - Remote radios in a carrier detect collision avoidance system, listen for a transmission (carrier) from the collision avoidance master, to determine if the collision avoidance master is currently busy receiving a transmission from another remote. When the collision avoidance master receives a transmission from a remote, it activates its own transmitter, indicating to all other remotes that the channel is busy.

In this mode of operation, remote radios can not distinguish between the collision avoidance master transmitting data and the collision avoidance master indicating the channel is busy.

Carrier Detect Mode can also be used without a collision avoidance master. This is typically implemented in simplex systems, or systems with a small number of remotes.

- **Digital** - Remote radios in a digital collision avoidance system, monitor a channel busy flag in the digital data stream transmitted from the collision avoidance master to determine if the collision avoidance master is currently busy receiving a transmission from another remote. When the collision avoidance master receives a transmission from a remote, it activates its own transmitter and sets the channel busy flag, indicating to all other remote the channel is busy. However, unlike carrier detect mode, if the collision avoidance master needs to transmit data to remotes, it can do so and clear the channel busy flag.

In this mode of operation, remote radios can distinguish between the collision avoidance master transmitting data and the collision avoidance master indicating the channel is busy. Even if the collision avoidance master is transmitting data, a remote radio can transmit data back to the collision avoidance master. In this way the radio system can fully utilise the full duplex capabilities of the Entry Point or the Repeater (collision avoidance master). The channel busy flag consumes a small amount of bandwidth in the collision avoidance master to remote direction. However, as this direction is one to many, it has negligible impact on radio network capacity.

Digital can be used in two frequency, PTMP and PTMP/R system topologies where the Entry Point or Repeater is full duplex. It is not available in simplex systems, or where the Entry Point/Repeater is half duplex or in PTMP via multiple Repeaters system topologies.

Collision avoidance operational examples:

Collision avoidance (C/A) has a number of user configurable parameters. These parameters work together with the specific mode of C/A chosen to minimise the number of collisions on the radio channel. Interaction of these parameters in C/A is best explained by reviewing the operational flow charts for common C/A configurations.

Digital Collision Avoidance Example 1

This flow chart shows the C/A operation in a remote radio with the following configuration:

- **C/A:** Digital
- **Backoff Method:** Retry After Tx attempt
- **Backoff time:**
 - **Max Slots:** 16
 - **Slot Time:** 20ms
- **Data Priority:** Tx Data

When data is ready to be transmitted, the remote radio checks the C/A busy flag to see if it is set (i.e. is the C/A master receiver busy). If the C/A busy flag is clear, the data is transmitted to the C/A master. If the C/A busy flag is set, the radio waits a random time before trying again.

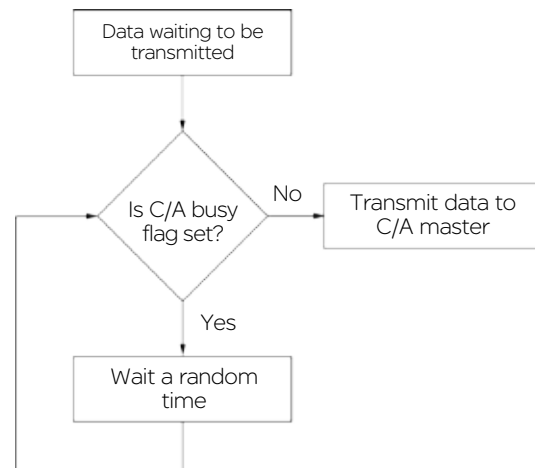

As it is possible that there may be more than one radio waiting to transmit data to the C/A master, a random wait time is applied, to avoid two radios waiting the same time, retrying and then colliding. There are multiple configurable parameters involved in when the wait time is applied and what amount of time is waited.

- **Backoff Method** - Defines 'when' a radio will implement the backoff time. In this example, the backoff method is configured to 'Retry After Tx Attempt'. If the C/A busy flag is clear, the remote will transmit data immediately. If the C/A busy flag is set, the remote will wait a random Backoff time and try again.

The Backoff time is calculated by choosing a random number between 1 and 'Max Slots' (in this example 16) and multiplying the number by the 'Slot Time' (in this example 20ms). In any remote radio, a smaller number of 'Max Slots' and 'Slot Time' can be configured to reduce the random Backoff time, which will increase the rate at which the radio checks the C/A busy flag. In effect, a radio with a smaller backoff time has a higher probability of transmitting its data first, in a situation where multiple remote radios are waiting for access the channel.

As the data priority is configured for Tx Data, the radio will transmit data even when an incoming data packet it being received.

This collision avoidance configuration provides maximum radio channel efficiency and are recommended when there is multiple asynchronous data traffic on the radio channel.

Digital Collision Avoidance Example 2

This flow chart shows the C/A operation in a remote radio with the following configuration:

- **C/A:** Digital
- **Backoff Method:** Delay Before Tx attempt
- **Backoff time:**
 - **Max Slots:** 16
 - **Slot Time:** 20ms
- **Data Priority:** Tx Data

When data is ready to be transmitted, the remote radio waits a random time before checking the C/A busy flag to see if it is set (i.e. is the C/A master receiver busy). If the C/A busy flag is clear, the data is transmitted to the C/A master. If the C/A busy flag is set, the radio repeats the wait time and tries again.

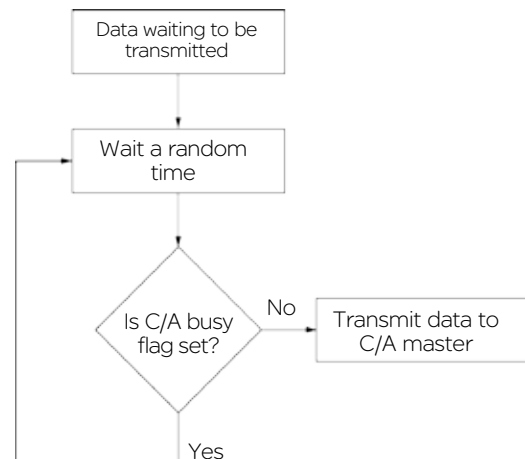

The primary difference when compared to example 1, is that the radio applies the random wait time before any attempt is made to check the C/A busy flag.

This collision avoidance configuration provides maximum radio channel efficiency when there is synchronous data traffic on the radio channel (i.e. GPS timing, synchronous exception reports).

Rx data 'Priority':

In PTMP/R system topologies, where the Entry Point radio is half duplex, the configuration of Rx data priority may be required. This is particularly useful for asynchronous traffic, such as a combination of SCADA exception reporting and polling. In this scenario, the probability that a data packet currently being receive by the Entry Point radio is for the Entry Point radio and not for a remote, is high. Therefore, without Rx data priority, incoming packets to the Entry Point radio would be lost if priority was given to transmitting packets.

Compression

The radio can apply compression to the payload of an IP packet, prior to transmitting it over the air. It can take up to 2 ms for the payload to be run through the compressor. Generally, once the payload has run through the compressor, the payload becomes smaller in size, reducing the amount of packets required to be transmitted, therefore, reducing over-all latency.

In some circumstances, the payload data can be 'un-compressible', meaning, once the payload has been run through the compressor, the payload is mostly the same size it was to begin with. This results in no reduced packet size being sent over the air, therefore, the time it took to run the payload through the compressor, will be added to the over-all latency. As this is only approximately 2 ms, it can be considered negligible when compared with the over-all latency of the radio link.

The default and recommended setting for compression is "Low".

Ethernet Filtering

Ethernet filtering provides an easy to configure Layer 2 filtering mechanism, which can help prevent unnecessary Ethernet traffic and increasing channel loading. There are various different addressing methodologies that can be filtered, which include:

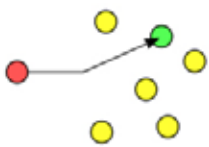

Unicast:

Unicast is an addressing methodology that delivers messages to a single network destination identified by a unique address.

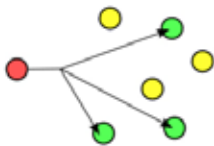

Multicast:

Multicast is an addressing methodology that delivers messages to a group of destination addresses simultaneously in a single transmission. Spanning tree messages are an example of multicast messages.

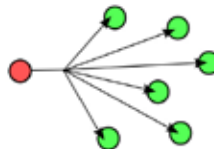

Broadcast:

Broadcast is an addressing methodology that delivers messages to every device on a network. The broadcast address of a device is calculated from the subnet mask. If all devices within a network use a common network mask, the broadcast address will also be common.

Although typical SCADA applications only require Unicast & ARP data, the filtering mechanism provides the option to allow:

- All Ethernet traffic
- ARP + Unicast + Multicast (Although Spanning tree messages are multicast messages, they are also filtered out unless the user is allowing all Ethernet traffic to pass. This also helps to prevent unnecessary channel loading.)
- ARP + Unicast (ARP is primarily used by networks to identify which physical devices own which IP addresses, Enabled by default).
- Unicast only (Only used when a MAC address table is statically assigned).
- Or allow traffic from a single MAC address only.

Connectivity

Embedded Serial Device Server

A serial device server can perform two tasks:

- Encapsulate serial data within IP headers to allow transportation of the serial data over a LAN/WAN.
- Take IP encapsulated serial data, strip off the IP headers and output the raw serial data.

Normally, systems require a standalone device server to integrate external serial devices at remote sites into a managed LAN/WAN. Q data radios provide the functionality of two embedded device servers which avoids the requirement for an external device server. The example below shows a traditional IP radio, Ethernet to serial topology, using an external device server.

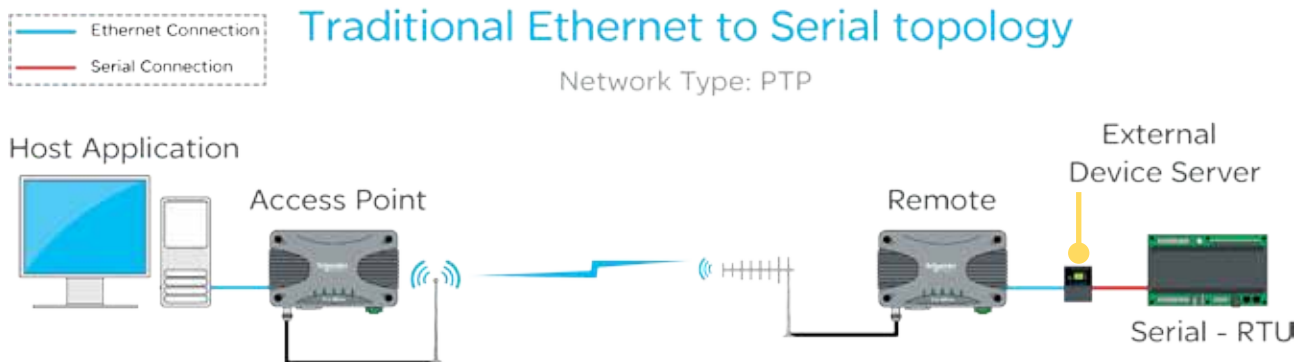

In a system that requires a serial connection to a remote end device and an Ethernet connection at the Host application end, the device server should be enabled within the remote radio. When the embedded device server is enabled, the remote radio provides the same functionality as if there was an external device server at the remote site. This functionality is also available in a PTMP system.

Device Server mode provides an easily configurable mechanism for transporting serial traffic that does not have any built-in addressing. The benefit of the device server feature is that device addressing can be performed using IP addresses for non-addressable serial protocols, without the need for external terminal servers or managing serial devices using the IP address of the remote radio.

Features of the embedded serial device server include:

- Support for two independent fully configurable serial device servers.
- Support for three transport protocols: TCP, UDP and PPP.
- Support for three modes of TCP operation: Client mode, Server mode and Client/Server mode.
- User-configurable port numbers.
- Support for up to 4 simultaneous TCP connections (sockets) when operating in server mode.

The diagram below shows a typical setup using the device server functionality in remote radios.

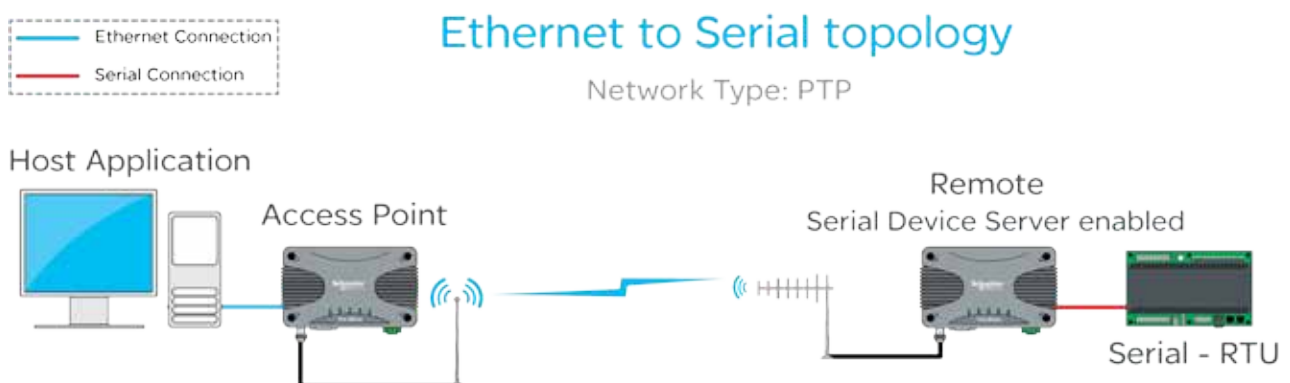

Embedded MODBUS Gateway

Q data radios have an embedded MODBUS Gateway feature that can be enabled to function like an external MODBUS gateway. The MODBUS gateway is a protocol converter between MODBUS/TCP and MODBUS RTU protocols. The gateway is an addition to the Device Server feature on the legacy serial port.

When operating in MODBUS gateway mode, the remote radio provides the same functionality as if there was an external MODBUS gateway at each remote site of the system. In traditional systems, standalone MODBUS gateways were required to convert the IP MODBUS TCP protocol to MODBUS RTU, the example below shows a traditional MODBUS TCP system using a stand-alone MODBUS gateway at each remote site.

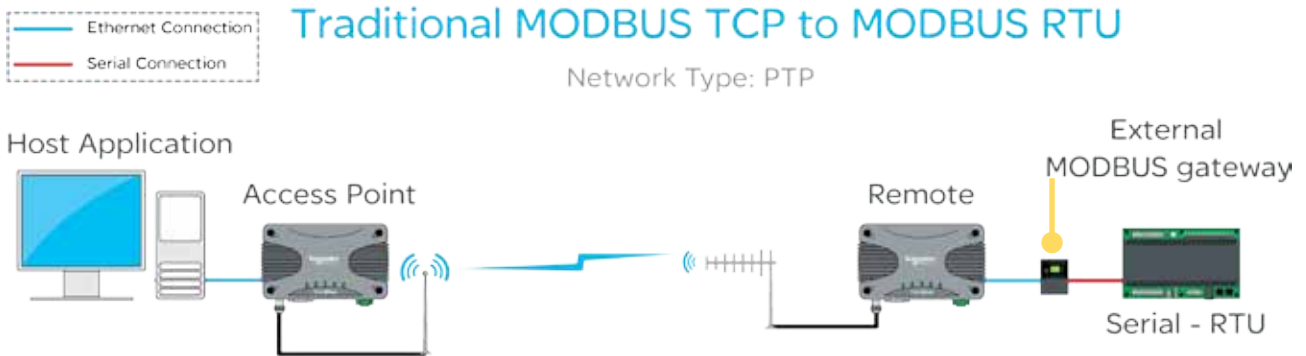

When operating in MODBUS gateway mode, the remote radio provides the same functionality as if there was an external MODBUS gateway at each remote site.

Features of the embedded MODBUS gateway include:

- Support for two independent fully configurable MODBUS gateways.
- Support for two transport protocols: TCP and UDP.
- Support for two modes of TCP operation: Client mode and Server mode.
- User-configurable port numbers.
- Support for up to 16 simultaneous TCP connections (sockets) when operating in server mode.

MODBUS gateway mode provides an easily configurable mechanism for transporting serial traffic over an IP network (LAN/WAN). A benefit of the MODBUS gateway feature is that the limitation of MODBUS addressing (0-255) can be ignored as the IP address of the radio can be used giving unlimited addresses to external equipment such as RTUs or PLCs. Below is an example of a typical system using the MODBUS gateway (remote) feature at each remote site to avoid the limitation of MODBUS addressing.

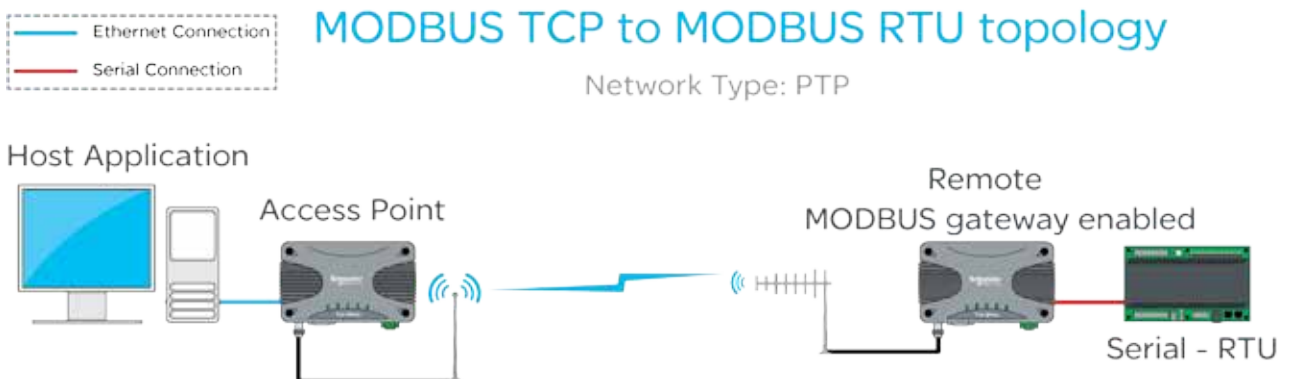

Network Address Translation (NAT)

Network Address Translation (NAT) provides a radio in IP routing mode, the ability to perform local port forwarding. Port forwarding can be beneficial in a network where:

- An IP network has run out of available IP addresses.
- Multiple devices co-exist on a single IP network while sharing the same IP address.

In a standard IP routing radio network, each radio behaves as a network gateway to each of the local subnets. This type of network consists of:

- A number of LANs: These are the subnetworks residing on the local side of each radio gateway. To subnet these networks, each LAN requires a uniquely allocated IP range.
- A single Radio WAN: Each radio gateway is configured with a unique WAN address. This creates a subnetwork for the radio channel.

NAT port forwarding can eliminate the requirement for unique addressing within the LAN subnets by translating the source address of message sent from a device residing on the LAN with the address allocated to the radio router's WAN network.

Devices residing on a local subnet will no longer be addressed by their unique IP address, rather, the IP address of the radio gateway along with a unique port number.

When port forwarding is being configured, each IP device within a local network is allocated one port number on the radio gateway and a port forwarding rule is entered into the gateway to define:

Gateway Listening Port - The port number which has been allocated to a single device on the radio gateways LAN.

When a message addresses this port number and forwarded to the radio gateway, the corresponding port forwarding rule will be executed.

IP address and port number of the allocated device - When the Gateway Listening Port is addressed, the corresponding rule is executed, where the message address will be translated to the IP address and port number defined in these rule parameters.

Virtual LAN (VLAN)

VLAN can help provide isolation between separate entities who share a single network.

For example, Department A may require access to radio configuration/Diagnostics, while Department B may only requires access to SCADA information. By implementing VLAN, a virtual network segregation can be implemented to help isolate each of the departments from one another.

The following diagram shows managed switches placing separate hosts onto unique VLANs. Each remote has been configured to use VLAN 1 on the ETH1 interface, which provides access to radio services, and VLAN 2 for the ETH2 interface for SCADA control access.

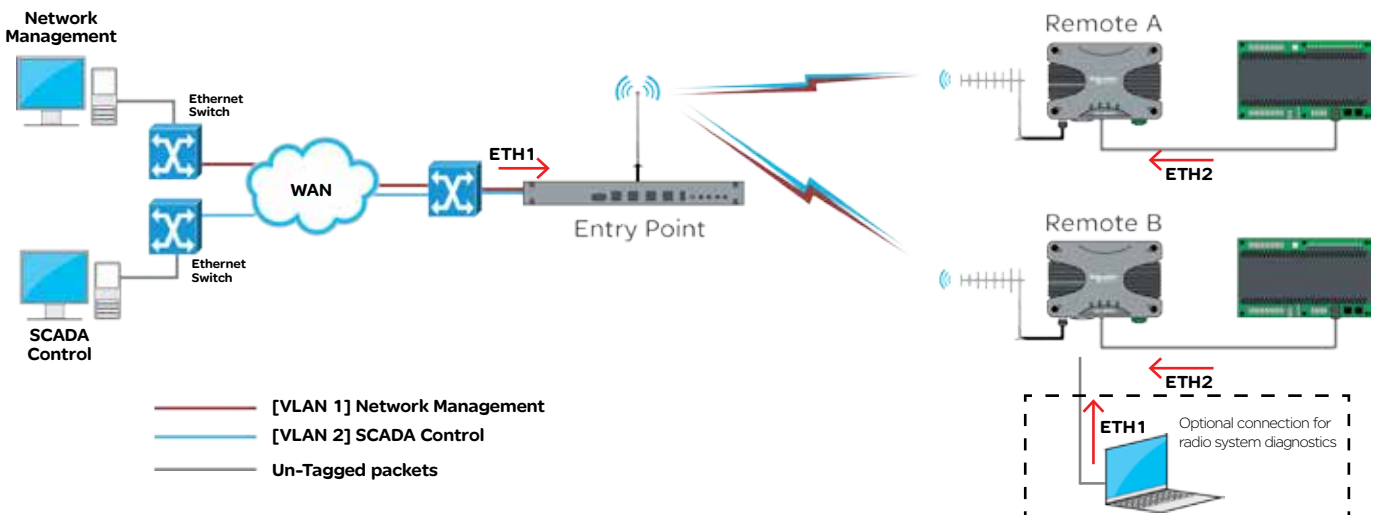

Ease of Use

Alarms and Events

The Q data radio can be configured to monitor specific diagnostic values and raise alarms or record events (i.e DC volts, Tx Power, etc). The radio's active condition can be evaluated by observing the event history and alarm states.

Event History

The events window displays the history of each event that has occurred. Each event contains a time/date stamp, an event ID, the severity level and a description of the event. Reviewing the event history can also help in fault diagnosis.

Events

24/11/1975 17:32:06	400	EVENT	Radio power up.
24/11/1975 17:32:06	501	EVENT	Radio firmware installation successful.
26/11/1975 20:33:22	500	EVENT	Radio firmware installation activated. 1.2.6.3524 -> 1.2.6.3545
24/11/1975 17:32:10	300	EVENT	Radio changed to online status.
24/11/1975 17:32:08	301	EVENT	Radio changed to offline status.
24/11/1975 17:32:06	400	EVENT	Radio power up.
24/11/1975 17:32:10	300	EVENT	Radio changed to online status.
24/11/1975 17:32:08	301	EVENT	Radio changed to offline status.
24/11/1975 17:32:06	400	EVENT	Radio power up.
24/11/1975 17:34:29	51	EVENT	Active critical alarms detected.
24/11/1975 17:34:29	190	CRITICAL	Operational critical alarm detected.
24/11/1975 17:33:21	300	EVENT	Radio changed to online status.
24/11/1975 17:33:18	301	EVENT	Radio changed to offline status.
24/11/1975 17:33:16	400	EVENT	Radio power up.
24/11/1975 17:33:16	300	EVENT	Radio changed to online status.

Alarm States

Alarms can be displayed in the following states: Disabled, Normal, Recovered, Warning or Critical.

Warning state thresholds for some alarms can be configured to best suit user requirements. This can provide early detection and notification before an issue becomes critical (i.e. Damaged antenna, lost power/battery backup, etc).

Alarm state changes can also be subscribed to by notification services such as SNMP and digital outputs.

ID	ALARM	STATE	CURRENT VALUE
50	Global Alarm		
60	Base Health		
100	Frequency Offset		
110	Received Signal Strength Indication (RSSI)		
120	VSWR		< 1.5:1
130	Tx Power		30.3dBm
140	DC Supply		12.0V
150	Temperature		35.0 (Deg C)
160	Ethernet Link		
170	PLL Lock		
180	Fan		
190	Operational		
200	Rx Packet Comparison		
210	RSSI Comparison		

SNMP Diagnostics

The Q data radio can provide SNMP diagnostic data via an internal SNMP agent. The radio supports SNMP v1 & v2c along with notifications which includes traps and informs. SNMP facilities include RFC1213, Ethernet diagnostics and radio diagnostics

The features and benefits of SNMP diagnostics include:

- SNMP messages/notifications that can be sent to Clear SCADA or SNMP management software.
- SNMP notifications that provide real time alarm detection reporting.
- Helping to eliminate the need for radio polling.
- Radios that can send diagnostic information via SNMP periodically (diagnostics heartbeat).

MIB files made available by Schneider Electric may be imported into most major SNMP Management consoles. These .MIB files define the contents of the SNMP parameters including a description for each parameter. The parameters are sorted into six distinct groups: General, Radio, Security, LAN, Error and Notification.

SNMP Notifications

The Q data radio have the capability to send SNMP notifications. An SNMP notification is a message to inform a user that a radio state has changed. These states include: input voltage, temperature, Tx power, etc. There are two types of SNMP notifications available: traps and informs.

- A trap is a single UDP message that is sent from the Q data radios to a user defined SNMP manger.
- An inform is still a UDP message, however, an inform requests a response to the UDP message sent. This allows retries and time outs to be used within the radio.

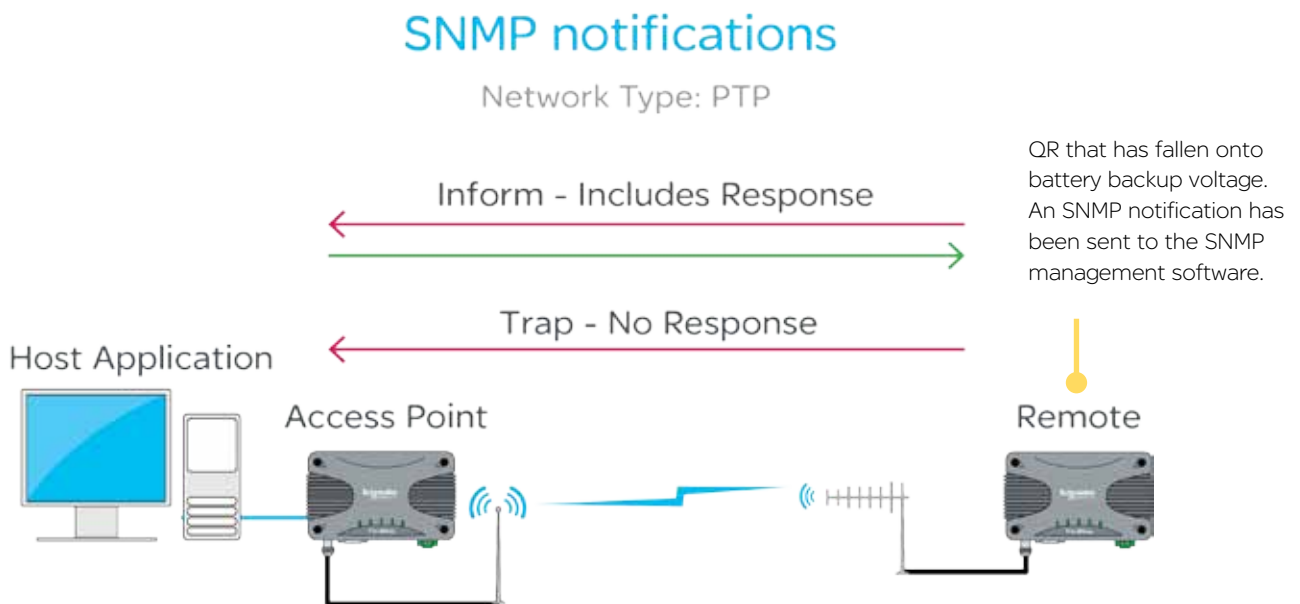

Web User Interface (WUI)

Q data radios provide a graphical Web User Interface (WUI) which can be accessed by a web browser to perform configuration changes. This helps to eliminate the requirement for stand-alone configuration software to be installed on a PC.



Text User Interface (TUI)

The text user interface (TUI) provides an alternative to the HTML web user interface for configuration and diagnostics. The TUI can be accessed directly from the serial port of the Q data radio or via a Telnet or SSH session. The TUI is enabled on COM 1 by default, while Telnet is also enabled by default, however, this requires an Ethernet connection. Access to the TUI via the serial port is useful if you have forgotten the IP address of the radio you are trying to configure or diagnose.

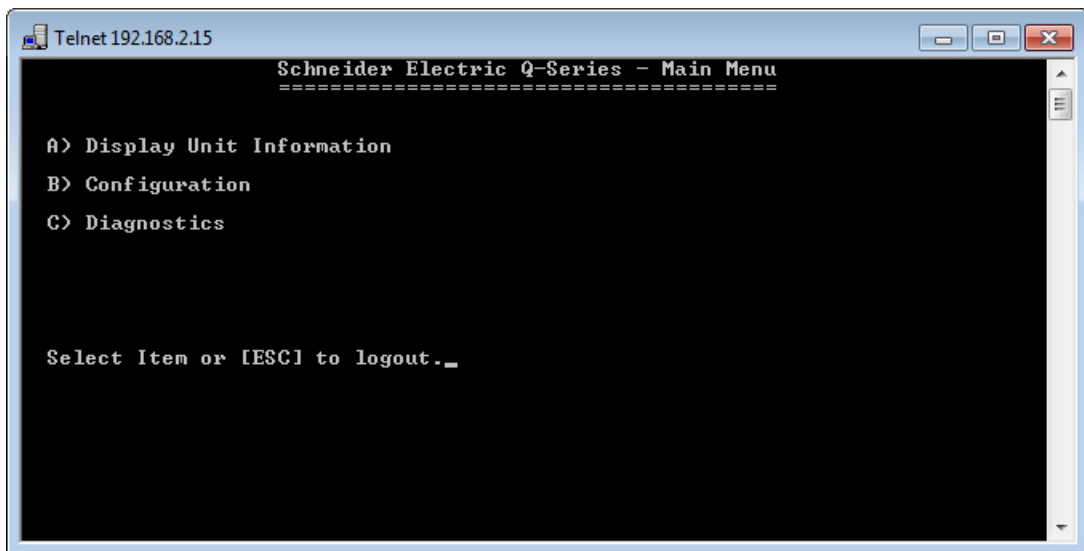

Diagnostics Tools

The Q data radios provide SNMP access to radio diagnostics as well as providing embedded (web) diagnostics and commissioning features.

Radio Diagnostics:

The Q data radios include the ability for installers to review useful radio & Ethernet diagnostics parameters. The parameters include unit specific (date & time), network specific (Ethernet traffic) and radio specific parameters (Tx Power, DC volts, etc). Diagnostics can be accessed via the web user Interface or using the TVIEW+ Diagnostics suite (via eDiags) or via serial console (COM 1 enabled by default). Diagnostics can also be accessed via SNMP.

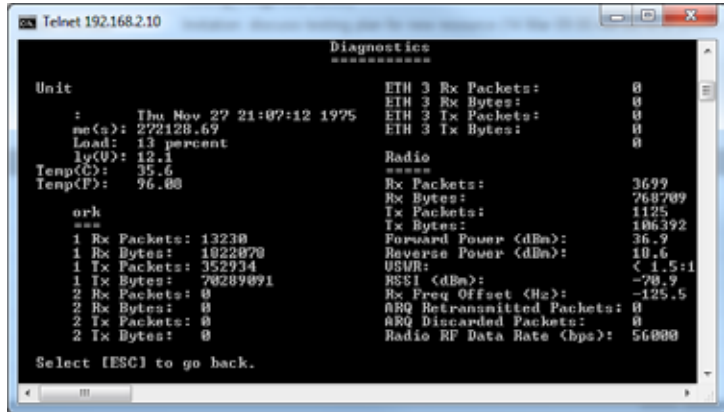

Statistics Log:

The Q data radios include the ability to measure and record radio diagnostics and performance statistics over a period of time. This facility is known as the statistics log. The statistics log can be configured to display/log data at a low, medium or high frequency depending on a user's requirements and can also be saved to a CSV file for further analysis.

Date		Up Time (sec)	CPU Load (%)	ETH 1 Rx Packets	ETH 1 Rx Bytes	ETH 1 Tx Packets	ETH 1 Tx Bytes	ETH 2 Rx Packets	ETH 2 Rx Bytes	ETH 2 Tx Packets	ETH 2 Tx Bytes	ETH 3 Rx Packets	ETH 3 Rx Bytes	ETH 3 Tx Packets	ETH 3 Tx Bytes	Radio Rx Packets	Radio Rx Bytes	Radio Tx Packets	Radio Tx Bytes	Radio Offline	
Mon	Nov 24 17:34:20	170	47.2	222	30055	223	90308	0	0	0	0	0	0	0	0	0	18	1224	N/A		
Mon	Nov 24 17:34:29	100	82.0	2	126	0	0	0	0	0	0	0	0	0	0	0	0	0	0	N/A	
Mon	Nov 24 17:34:34	171	45.0	192	33245	196	76613	0	0	0	0	0	0	0	0	0	0	0	0	N/A	
Mon	Nov 24 17:34:44	182	87.0	48	7003	0	0	0	0	0	0	0	0	0	0	0	4	208	N/A		
Mon	Nov 24 17:34:47	185	82.8	0	0	0	0	0	0	0	0	0	0	0	0	0	0	0	0	N/A	
Mon	Nov 24 17:34:48	184	73.0	83	9110	0	0	0	0	0	0	0	0	0	0	0	0	0	0	N/A	
Mon	Nov 24 17:34:47	185	8.4	0	0	0	0	0	0	0	0	0	0	0	0	0	0	0	0	N/A	
Mon	Nov 24 17:34:48	185	24.4	0	0	0	0	0	0	0	0	0	0	0	0	0	0	0	0	N/A	

Packet Transmission Testing:

When commissioning a radio link, it is useful to generate Ethernet traffic to test the link for functional performance. One method of generating traffic is using the “ping” utility provided on MS Windows based operating systems. Another method is to perform a packet transmission test. This can be done using the “Packet Transmission Test” facility provided in the radio.

To perform the test, the user specifies the destination radio or Ethernet device IP address, number of packets to send, time between packets (in milliseconds), packet length (in bytes), timeout and time between page refreshing. The test facility will then execute the test and provide the results, which can then form part of the commissioning process.

Broadcast Firmware Upgrades

The TView+ Management Suite provides an over-the-air firmware update tool for Q Data radios. The firmware update feature is speed-limited to help prevent RF channel congestion and can broadcast to all of the remotes within a Q data radio system.

Broadcasting to all remotes has the benefit of upgrading the alternative firmware pack in many radios simultaneously, without the need to send firmware to each remote radio individually. Due to the speed-limiting of the firmware upgrade process, SCADA data will not be blocked or interfered with while firmware packs are being transferred.

Each radio stores two sets of firmware. The current firmware pack is the firmware the radio is running from. The alternative firmware pack is a secondary (optional) area where alternative firmware can be stored. When the alternative firmware pack has been updated, it can then be activated which moves the alternative firmware into the current firmware pack area, and causes the radio to reboot using the new firmware.

The firmware upgrade tool also provides the capability of individual activation or group activation, depending on user preference. Firmware upgrades are typically done using “patch” files where only the difference between the current and target firmware is actually sent. This reduces the over the air transmission of firmware data by up to 90%

See Part J for detailed information on this topic.

Trio E-Series Emulation Mode

Trio Q data radios can be configured to operate in E-Series mode. This can help a user to determine the length of time a full system upgrade will take. See the examples below:

Typical E-Series system - Stage 1

The diagram below shows a typical E-Series system.

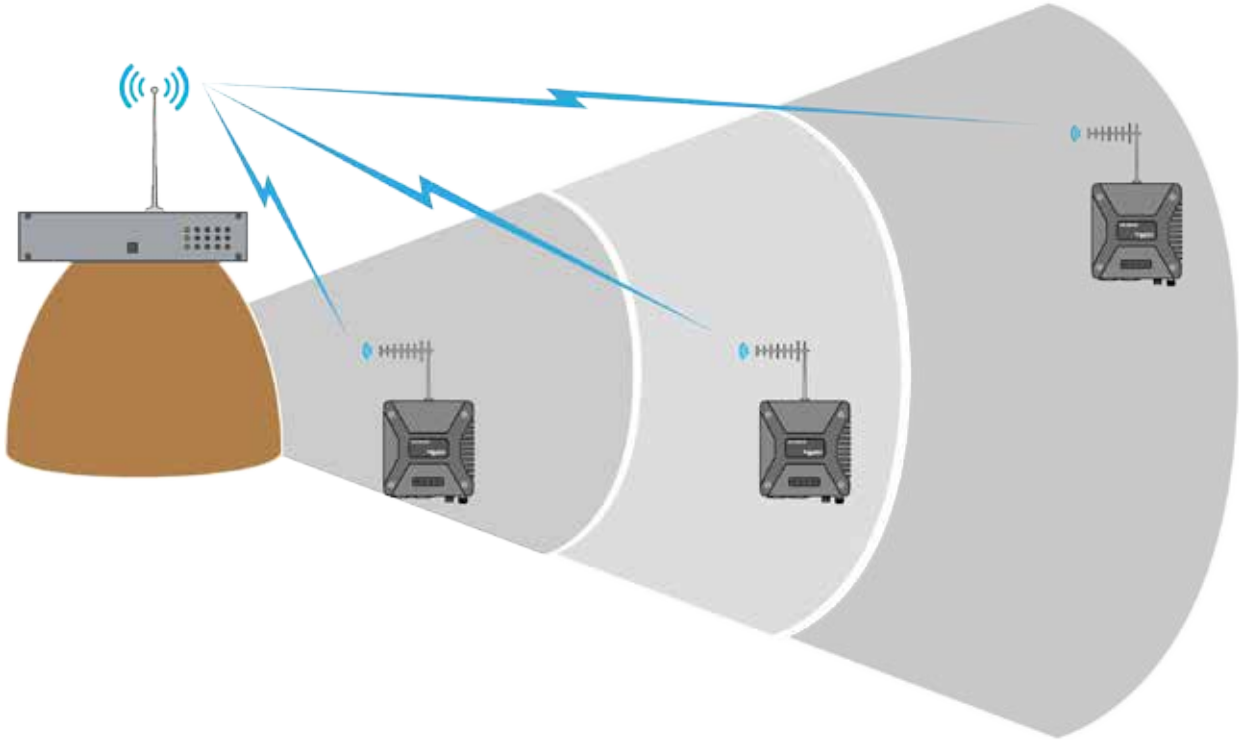

E-Series system upgrade - Stage 2

New installations or replacements of E-Series radios can be performed with Q data radios operating in E-Series compatibility mode. This allows for a controlled and steady system upgrade. The diagram below shows Q data radios operating within an E-Series system.

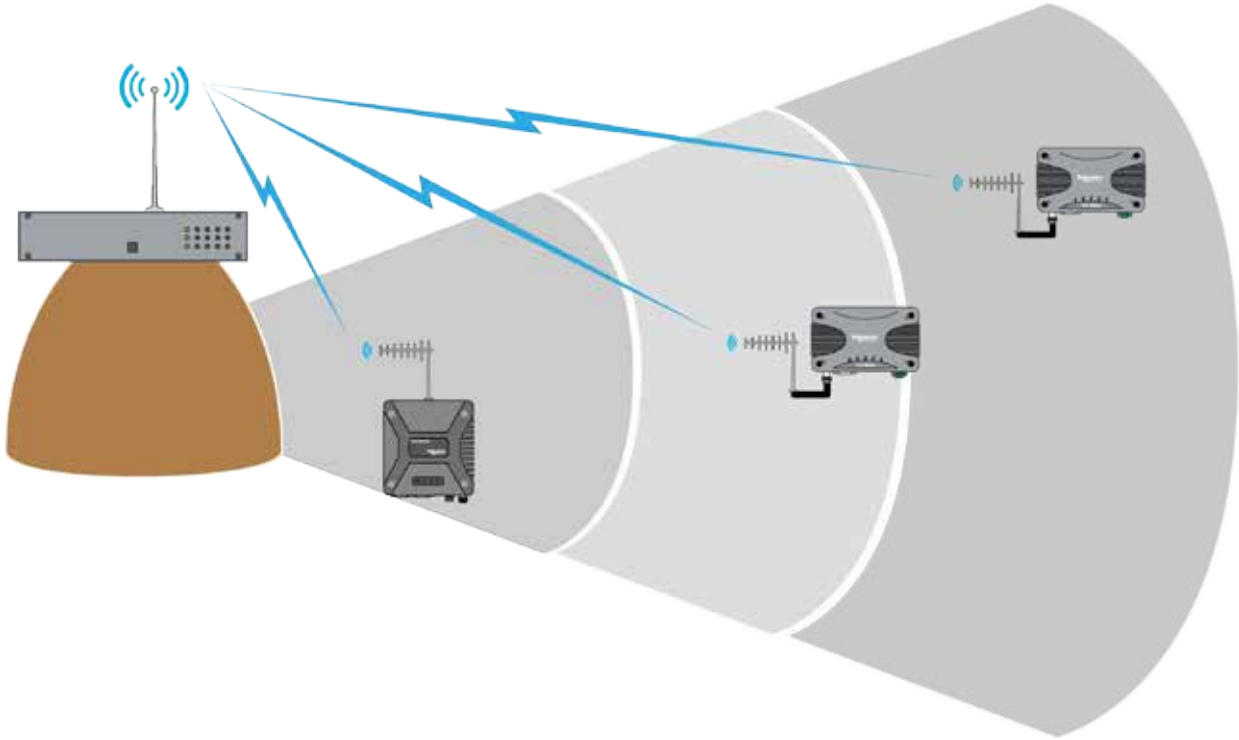

Switch system to Q Mode - Stage 3

Once all E-Series have been replaced, the Q data radios may be re-configured to operate in Q mode, to provide advanced features and functionalities of the Q data radios.

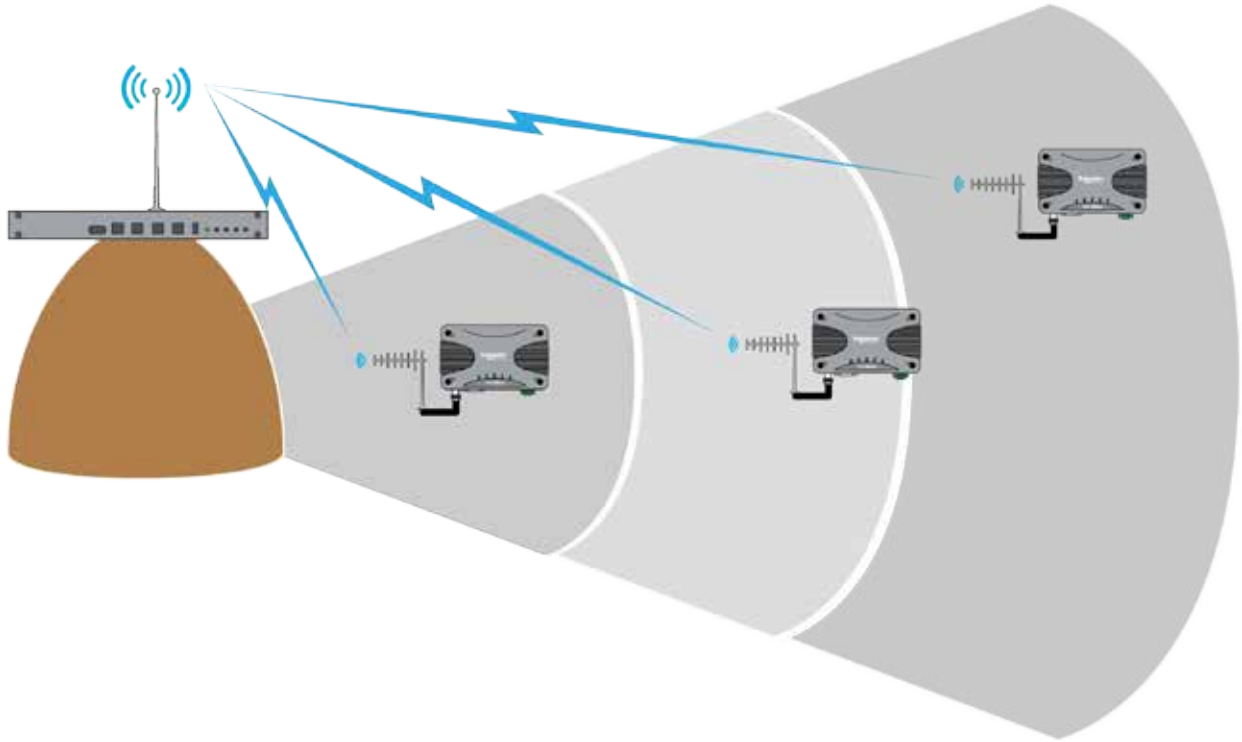

Security

Password protection and User Administration

Multiple users can be created and managed with different configuration privilege levels.

The different privilege access levels include: Unrestricted, Read/Write/Security, Read/Write, Read Only.

For more detail refer to Part H 'User Administration'.

Configuration information can be protected by a user-defined login name and password. When a password is set, the programmer will request the password each time the radio is read. No configuration information can be displayed or changed without the entry of the correct password.

AES encryption

The 256-bit AES encryption feature can provide an encrypted channel that helps to prevent eaves-dropping and snooping. The effort for configuration is minimal as the radio automatically adjusts, to keep packet transport compatible (i.e.: MODBUS messages are not broken up). Enabling encryption requires additional overhead depending on packet sizes being sent.

Secure Shell (SSH)

SSH provides a secure and authenticated method for remotely accessing the Q data radios text user interface (TUI) for configuration and diagnostics.

To access Q data radios via SSH, the network management PC requires an SSH-capable program (i.e.: Putty).

All traffic over the SSH connection is encrypted.

During the first connection to the SSH terminal software, a "fingerprint" of the remote device is taken and stored on the Network Management PC. This allows for authentication in the future.

The SSH session also requires the user to enter a user name and password for authorised access to the TUI.

SSH example:

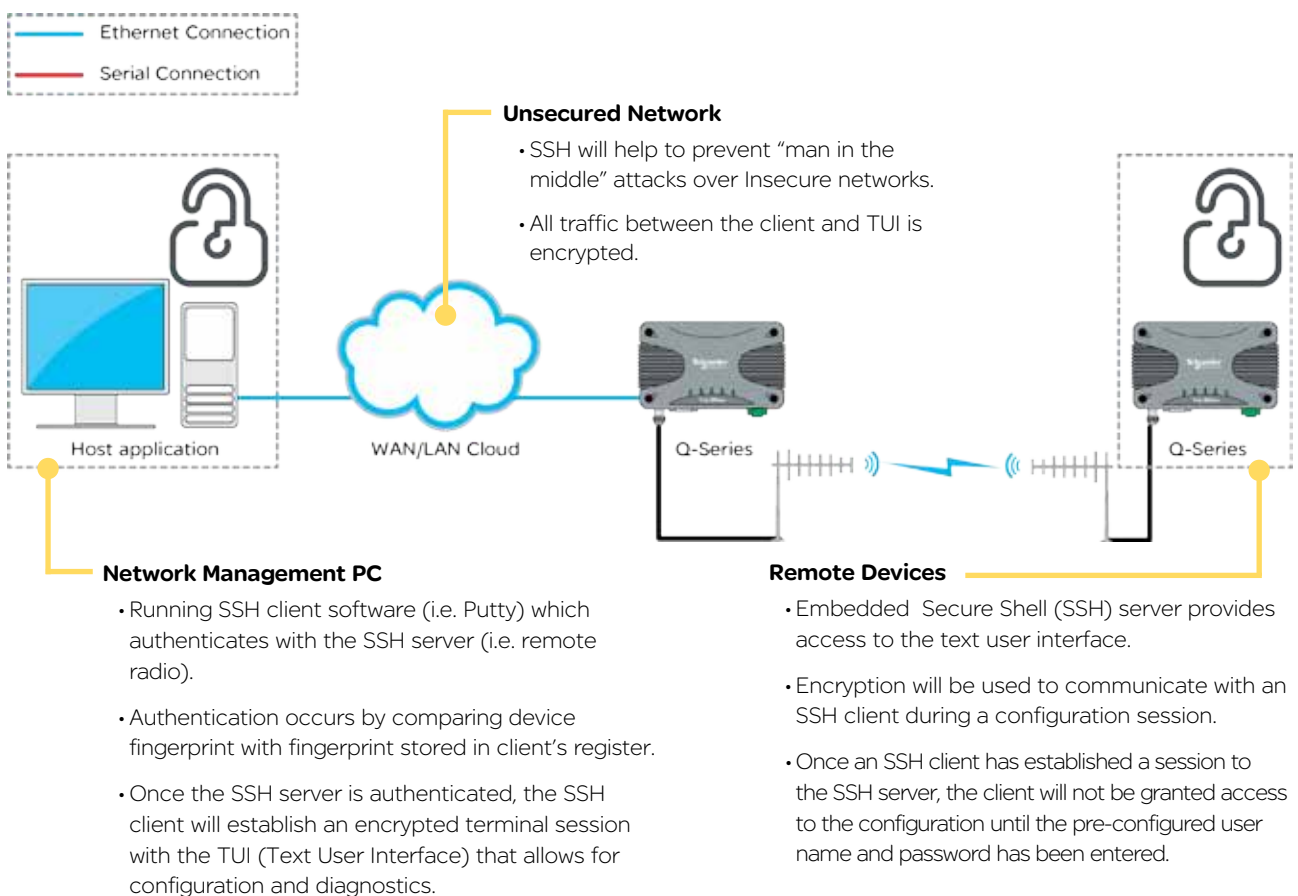

HTTP Secure (HTTPS)

HTTPS provides a secure and authenticated method for remotely accessing the Q data radios Web User Interface (WUI) for configuration and diagnostics.

To access the Q data radios via HTTPS, use a web browser which has HTTPS capabilities. Common web browsers which provide HTTPS capabilities include: Internet Explorer, Firefox and Chrome.

The HTTPS client (web browser) will request a digitally-signed certificate from the HTTPS server (Q data radios) to help ensure that the target device is authentic.

All traffic over the HTTPS connection is encrypted.

Two methods of certificate management are available: Self-signed certificates generated by the radio itself or the use of certificates generated by external certificate servers.

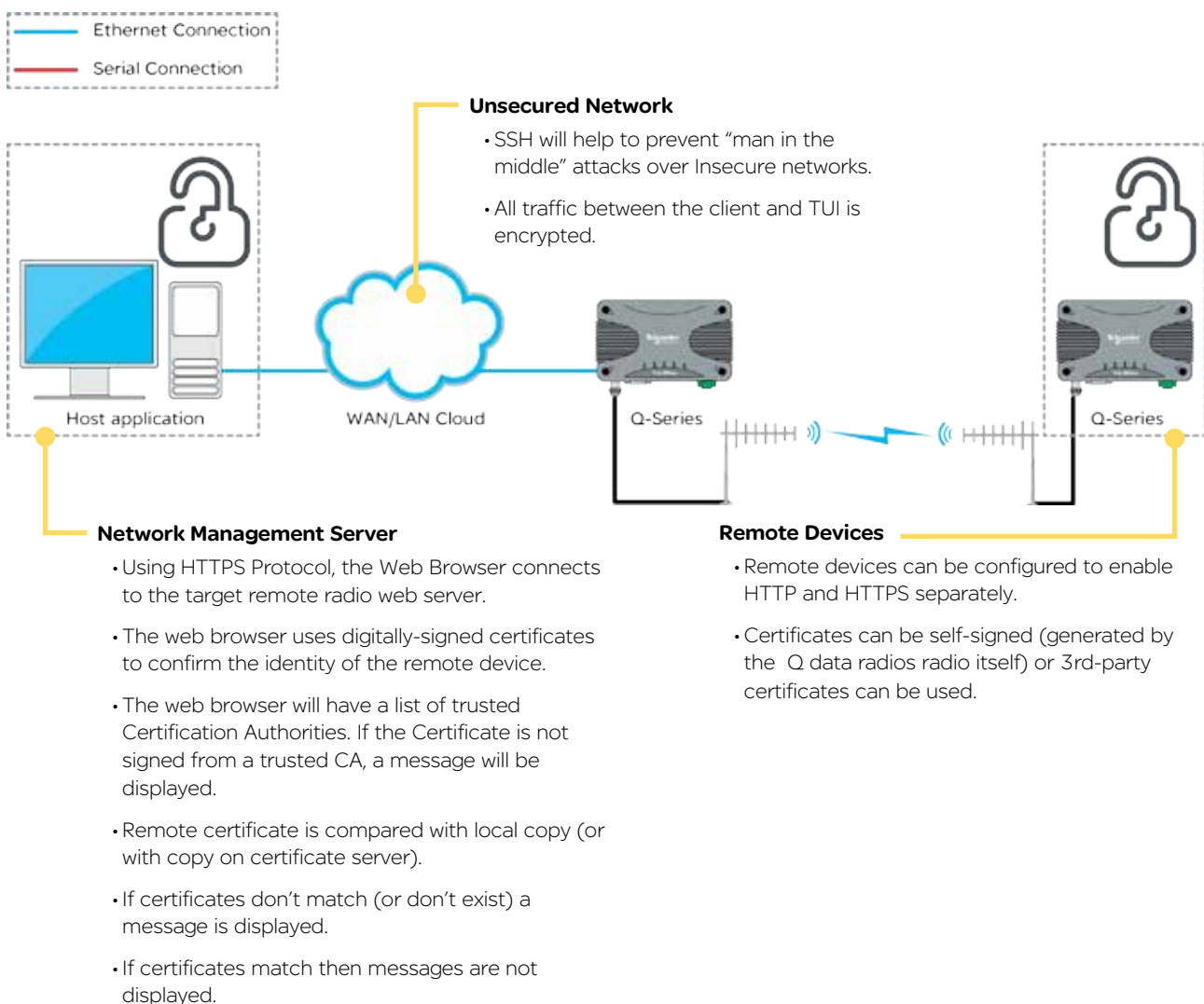

Part E – Radio Planning and Design

Radio Path analysis

Clear line of sight

Radio path with good signal levels, attenuated only by free space loss.

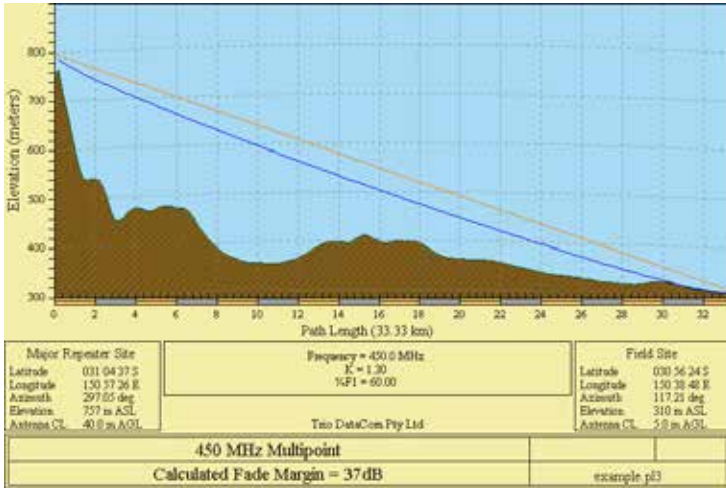

Obstructed Radio Path

This path has an obstruction that will reduce the signal arriving at the field site.

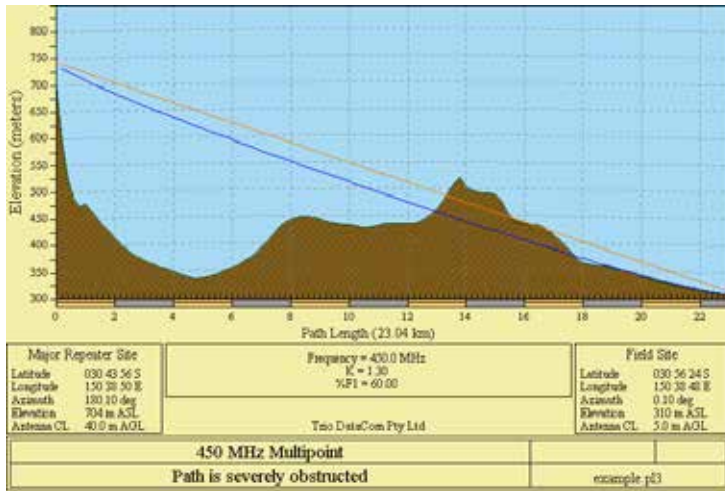

GOODPATH2400.p14	Major Repeater Site	Field Site
Elevation (m)	756.69	309.67
Latitude	31 04 37.49 S	30 56 24.00 S
Longitude	150 57 26.34 E	150 38 48.00 E
True azimuth (°)	297.05	117.21
Vertical Angle (°)	-0.94	0.72
Antenna Model	6dB Omni	16dB Grid Reflector
Antenna Height (m)	40.00	5.00
Antenna Gain (dBi)	8.15	18.15
(dBd)	6.00	16.00
TX Line Type	LDF4-60	LDF4-60
TX Line Length (m)	40.00	5.00
TX Line Unit loss (dB /100 m)	6.79	6.79
TX Line loss (dB)	2.72	0.34
Connector loss (dB)	2.00	2.00
Frequency (MHz)	2400.00	
Polarization	Vertical	
Path Length (km)	33.33	
Free Space loss (dB)	130.53	
Diffraction loss (dB)	0.00	
Net Path loss (dB)	111.29	111.29
Radio Model	HR240	HR240
TX power (watts)	1.00	1.00
(dBm)	30.00	30.00
Effective Radiated Power (Watts)	1.34	23.23
(dBm)	31.28	43.66
RX Sensitivity (µv)	1.26	1.26
(dBm)	-105.00	-105.00
RX Signal (µv)	19.28	19.28
(dBm)	-81.29	-81.29
RX Field Strength (µv/m)	1014.39	243.90
Fade Margin (dB)	23.71	23.71
Rayleigh Fade Probability (%)	0.42	0.42
Log Normal Fade Probability (%)	3.88E-03	3.88E-03

Understanding RF Path Requirements

A radio modem needs a minimum amount of received RF signal to operate reliably and provide adequate data throughput.

In most cases, spectrum regulatory authorities will also define or limit the amount of signal that can be transmitted, and the transmitted power will decay with distance and other factors, as it moves away from the transmitting antenna.

It follows, therefore, that for a given transmission level, there will be a finite distance at which a receiver can operate reliably with respect to the transmitter.

Apart from signal strength reduction due to distance, other factors that will decay a signal include obstructions (hills, buildings, foliage), horizon (effectively the bulge between two points on the earth), and factors such as fog, heavy rain-bursts, dust storms, etc.

In order to ascertain the available RF coverage from a transmitting station, it will be necessary to consider these factors. This can be done in a number of ways, including

- Using basic formulas to calculate the theoretically available signal - allowing only for free space loss due to distance,
- Using sophisticated software to build earth terrain models and apply other correction factors such as earth curvature and the effects of obstructions, and
- By actual field strength testing.

It is good design practice to consider the results of at least two of these models to design a radio path.

Effect of Earth Curvature on Long Paths

This path requires greater mast height to offset the earth curvature experienced at such a distance (73km).

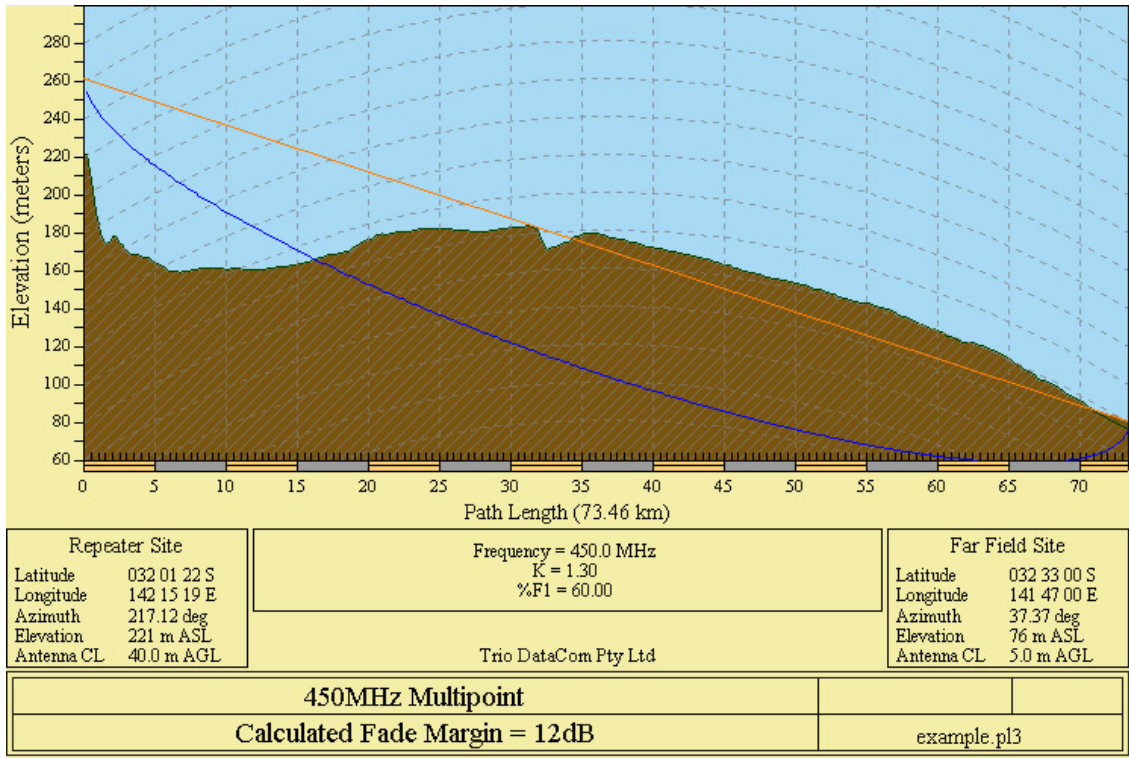

LONGPATH.PL3	Repeater Site	Far Field Site
Elevation (m)	221.26	75.58
Latitude	32 01 21.63 S	32 33 00.00 S
Longitude	142 15 19.26 E	141 47 00.00 E
True azimuth (°)	217.12	37.37
Vertical Angle (°)	-0.37	-0.03
Antenna Model	6dB Omni	15dB Grid Reflector
Antenna Height (m)	40.00	5.00
Antenna Gain (dBi)	8.15	17.15
(dBd)	6.00	15.00
TX Line Type	LDF4-50	LDF4-50
TX Line Length (m)	40.00	5.00
TX Line Unit loss (dB /100 m)	6.79	6.79
TX Line loss (dB)	2.72	0.34
Connector loss (dB)	2.00	2.00
Frequency (MHz)	2400.00	
Polarization	Vertical	
Path Length (km)	73.46	
Free Space loss (dB)	137.39	
Diffraction loss (dB)	34.02	
Net Path loss (dB)	153.18	153.18
Radio Model	HR240	HR240
TX power (watts)	1.00	1.00
(dBm)	30.00	30.00
Effective Radiated Power (Watts)	1.34	18.45
(dBm)	31.28	42.66
RX Sensitivity (µv)	1.26	1.26
(dBm)	-105.00	-105.00
RX Signal (µv)	0.16	0.16
(dBm)	-123.18	-123.18
RX Field Strength (µv/m)	8.16	2.20
Fade Margin (dB)	-18.18	-18.18

Location - Woodland (sigma = 6 dB)

BER & Fade Margin

The BER specification used by the Q data radios shows '1 x 10E -6 BER'. This means one bit of data in a million bits of data will error at the BER threshold level. The BER threshold values can vary depending on the over the air data rate (RF speed). The BER thresholds can be found in the table shown.

Regulatory Region	Channel Bandwidth (KHz)	RF Speed (Kbps)	BER threshold (10 ⁻⁶)	
			VHF (150)	UHF (450)
FCC/IC	12.5	8	-113	-113
		16	-111	-110
		24	-108	-107
		32	-100	-100
ACMA/ ETSI	12.5	8	-113	-113
		16	-111	-110
		24	-108	-107
		32	-100	-100
	25	14	-109	-111
		28	-107	-109
		42	-105	-106
		56	-98	-99

Fade Margin is the amount by which a received signal level may be reduced without causing system performance to fall below a specified threshold value, in this case, the specified threshold value is defined by the radio's Bit Error Rate (BER).

20dB to 30dB fade margins are typical design targets, however, 15dB may still be acceptable if this is all that is possible.

Fade margin is required to maintain the radio link quality if the signal fades, factors that can influence signal fading include:

- Reflections
- Rain
- Maintenance Issues

When a Q data radio system is configured for Dynamic mode, the 20 dB (typical) fade margin calculation may be performed using the lowest data rate, for best receiver sensitivity. (8 kbps in a 12.5 kHz channel or 14 kbps in a 25 kHz channel) This helps to ensure that a strong reliable path when conditions are poor.

The amount of fade margin a radio link has can be calculated by performing a theoretical system gain calculation.

Factors that can influence system gain include: Tx power of Transmitting Radio, Coaxial Cable, Antenna Gains, Free Space Loss, Rx sensitivity of receiving radio. See the example below.

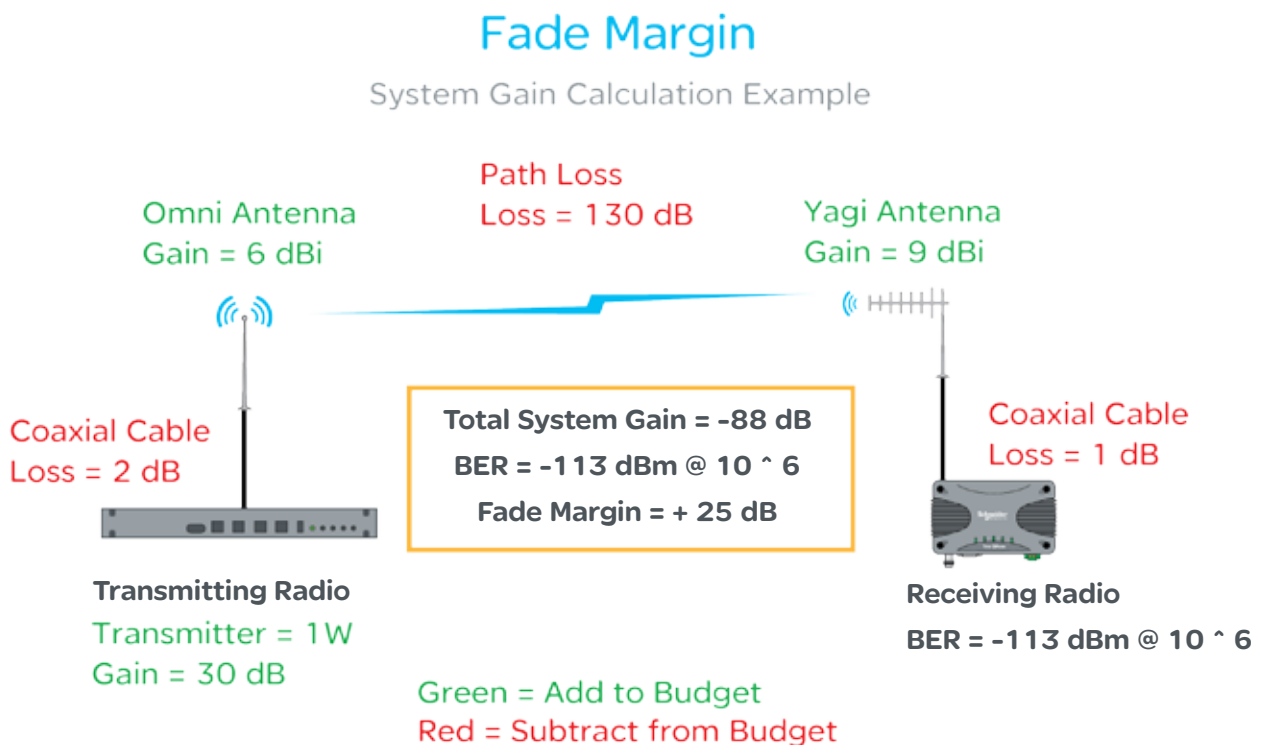

The example is showing the factors within a radio link that can influence the signal strength of the transmitting radio at the receiving radio (total system gain). Once the total system gain is calculated, the result is -88 dB. This means the received signal strength (RSSI) at the receiving radio should be -88dBm.

As the BER threshold of the receiving radio is at -113 dBm, with an RSSI value of -88, the fade margin, before 1 bit in a million bits of data become lost, is 25 dB. In other words, the RSSI level at the receiving radio can fluctuate up to -25 dB before data loss may start to occur in over the air transmissions.

Radio Accessories

Antennas

There are basically two types of antennas – omnidirectional and directional.

Omnidirectional antennas are designed to radiate signal in a 360 degrees segment around the antenna. Basic short range antennas such as folded dipoles and ground independent whips are used to radiate the signal in a “ball” shaped pattern. High gain Omni antennas such as the “co-linear” compress the sphere of energy into the horizontal plane, providing a relatively flat “disc” shaped pattern which goes further because all of the energy is radiated in the horizontal plane.

Directional antennas are designed to concentrate the signal into a “beam” of energy for transmission in a single direction (i.e. For point-to-point or remote to base applications).

Beamwidths vary according to the antenna type, and so can be selected to suit design requirements. The most common directional antenna is the YAGI, which offers usable beam widths of 15-40 degrees. Higher “gain” is available using parabolic “dish” type antennas such as gridpacks.

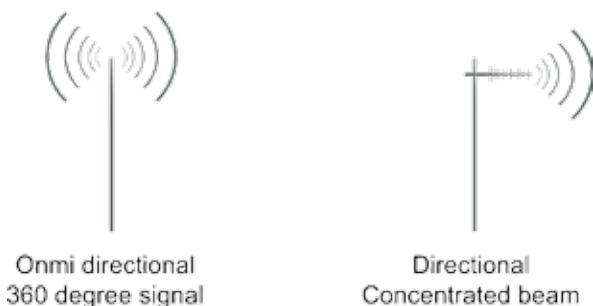

Schneider Electric offers a variety of directional and omnidirectional antennas. For further information, refer to the wireless accessories data sheet.

Antenna Gain

By compressing the transmission energy into a disc or beam, the antenna provides more energy (a stronger signal) in that direction, and thus is said to have a performance “gain” over a basic Omni antenna. Gain is usually expressed in dBd, which is referenced to a standard folded dipole. Gain can also be expressed in dBi, which is referenced to a theoretical “isotropic” radiator. Either way, if you intend to send and receive signals from a single direction, there is advantage in using a directional antenna - due to the increased signal in the wanted direction, and the relatively decreased signal in the unwanted direction (i.e. “Interference rejection” properties).

Alignment of Directional Antennas

This is generally performed by altering the alignment of the antenna whilst measuring the received signal strength. If the signal is weak, it may be necessary to pre-align the antenna using a compass, GPS, visual or map guidance in order to “find” the wanted signal. Yagi antennas have a number of lower gain “lobes” centred around the primary lobe. When aligning for optimal signal strength, the antenna should be scanned through at least 90 degrees, to help ensure that the centre (strongest) lobe is identified.

When aligning a directional antenna, avoid placing hands or body in the vicinity of the radiating element or the forward beam pattern, as this will affect the performance of the antenna.

Antenna Placement

When mounting the antenna, it is necessary to consider the following criteria:

The mounting structure will need to be solid enough to withstand additional loading on the antenna mount due to extreme wind, ice or snow (and in some cases, large birds).

For Omni directional antennas, it is necessary to consider the effect of the mounting structure (tower mast or building) on the radiation pattern. Close-in structures, particularly steel structures, can alter the radiation pattern of the antenna. Where possible, Omni antennas should be mounted on the top of the mast or pole to minimise this effect. If this is not possible, mount the antenna on a horizontal outrigger to get it at least 1-2m (3-6 ft) away from the structure. When mounting on buildings, a small mast or pole, 2-4m (6-12ft) can significantly improve the radiation pattern by providing clearance from the building structure.

For directional antennas, it is generally only necessary to consider the structure in relation to the forward radiation pattern of the antenna, unless the structure is metallic, and of a solid nature. In this case it is also prudent to position the antenna as far away from the structure as is practical. With directional antennas, it is also necessary to ensure that the antenna cannot move in such a way that the directional beamwidth will be affected. For long YAGI antennas, it is often necessary to install a fibreglass strut to stabilise the antenna under windy conditions.

Connecting Antennas and RF Feeders

The RF antenna system should be installed in accordance with the manufacturer’s notes. Consider the antenna gain when setting transmit power on the radio. EIRP limits will vary depending on your geographic location. Check with your local authority to ensure that you are abiding to the local laws.

▲ WARNING

HAZARD OF RADIO FREQUENCY (RF) BURNS

Ensure that a matching load or antenna is attached to the RF port prior to applying power to the device.

Failure to follow these instructions can result in death or serious injury.

RF Adaptors

RF adaptors can be useful where, two connectors are not of the same type, however, need to be connected (i.e. an antenna port of a radio and an RF lead which interconnects the antenna)

Schneider Electric offers a variety of RF adaptors:

RF Adaptors	
Order Code	Notes
TBUMRFAPT-TNCF-NM	Trio RF Adapter TNC-Female to N-Male
TBUMRFAPT-TNCF-SMM	Trio RF Adapter TNC-Female to SMA-Male
TBUMRFAPT-NF-NF	Trio RF Adapter N-Female to N-Female - Flange Mount

RF Coaxial Cable

There are many types of RF coaxial cables available, but it is sometimes difficult to know which type of cable to use.

There are two main aspects of a cable to consider when selecting the right cable for the job.

Bend Radius:

The bend radius of a cable is a specification given to a cable to define how flexible the cable is. Exceeding the bend radius specification can change characteristics within the cable and lead to reduced RF performance. The thicker the cable is, the wider its bend radius will be, however, the thicker the cable, the lower its electrical resistance will be, providing less impact on the radio system gain.



The cable connected from the radio to the lightning arrestor is typically quite short. This allows a thin, flexible cable to be used. Thin flexible cables have a higher electrical resistance characteristic than thick rigid cables, but as there is only a short length being used, the impact on radio system gain is negligible. The thick rigid cable is typically connected from the hut to the top of an antenna mast connected to an antenna.

Antenna Feedline Cable Loss:

The antenna feedline cable supplies the connection between the radio and the antenna. When long lengths of cable are required, it is important to factor-in the cable loss associated with length and type of cable being used.

Feeder Tail Cables

Typical installations use a thin, flexible RF cable, to interconnect the radio, to the outside of a hut/cabinet, these cables are called 'Feeder Tail Cables'.

Schneider Electric offers a variety of Feeder Tail Cables:

Feed Tail Cables	
Order Code	Notes
TBUMRFJP-TNC-N-05M	Trio RF Cable Feeder Tail 1.5Ft/0.5m - TNC-Male to N-Male
TBUMRFJP-TNC-N-1M	Trio RF Cable Feeder Tail 3Ft/1m - TNC-Male to N-Male
TBUMRFJP-N-N-1M	Trio RF Cable Feeder Tail 3Ft/1m - N-Male to N-Male
TBUMRFJP-SMA-N-1M	Trio RF Cable Feeder Tail 3Ft/1m - SMA-Male to N-Male
TBUMRFJP-DUPLX-BP	Trio Band Pass Duplexer Cable Kit 3Ft/1m - Double-Screened RF223/U with N-Male to N-Male. (QTY of 2). Suits TBUMDUPLXBPxxx

Feeder Tail Cables

As the antenna needs to be mounted up high, a longer length of RF cable needs to run from the outside of the hut/ cabinet, to the antenna, this cable is called 'Antenna Feedline Cable'.

Schneider Electric offers a variety of Antenna Feedline Cables:

Antenna Feedline Cables	
Order Code	Notes
TBUMRFANT-99F30M-B	Trio RF Cable Antenna Feedline 99Ft/30m, 0.5in/13mm Heliac N-Male To N-Male (LDF4-50A or equivalent)
TBUMRFANT-75F22M-B	Trio RF Cable Antenna Feedline 75Ft/22m, 0.5in/13mm Heliac N-Male To N-Male (LDF4-50A or equivalent)
TBUMRFANT-75F22M-A	Trio RF Cable Antenna Feedline 75Ft/22m, 0.4in/10mm N-Male To N-Male (LMR-400 or equivalent)
TBUMRFANT-50F15M-A	Trio RF Cable Antenna Feedline 50Ft/15m, 0.4in/10mm N-Male To N-Male (LMR-400 or equivalent)
TBUMRFANT-25F7M-A	Trio RF Cable Antenna Feedline 25Ft/7m, 0.4in/10mm N-Male To N-Male (LMR-400 or equivalent)
TBUMRFANT-10F3M-A	Trio RF Cable Antenna Feedline 10Ft/3m, 0.4in/10mm N-Male To N-Male (LMR-400 or equivalent)

As typical installations using antenna feedline cables use long lengths, it is important to consider the loss characteristics of the cable being used, see the loss characteristics table below:

Antennas Feedline Cable Loss characteristics								
Cable Diameter [order code reference]	150 MHz		450 MHz		900 MHz		2500 MHz	
	dB/100 ft	dB/100 m	dB/100 ft	dB/100 m	dB/100 ft	dB/100 m	dB/100 ft	dB/100 m
10 mm (0.4 in.) [TBUMRFANT-xxxxxx-A]	1.5	5.0	2.7	8.9	3.9	12.8	6.8	22.2
13 mm (0.5 in.) Heliac [TBUMRFANT-xxxxxx-B]	0.8	2.7	1.5	4.8	2.1	6.9	3.6	12.0

Lightning Arrestors

A lightning arrestor is used to help minimise lightning damage to radio devices. Lightning arrestors are made to bleed off electrostatic build-up to help prevent a direct lightning strike from hitting the antenna system. Also, if a lightning strike happens nearby, the arrestor helps to route the energy to ground.

The lightning arrestor is typically installed on the inside of a radio hut, between a coaxial tail lead the antenna feeder cable. The lightning arrestor comes with an N-Type female socket on each end.

Schneider Electric offers a variety of Lightning Arrestors:

Lightning Arrestors						
Order Code	Frequency range	Protected Side Connector	Surge Side Connector	Mounting Style	VSWR	Notes
TBUMLT-ARRES-TYPEA	125 MHz to 1 GHz	N-Female	N-Female	Bulkhead with right angle bracket	1.1:1	Turn-on: 600 Vdc 120%
TBUMLT-ARRES-TYPEB	2 to 6 GHz	N-Female	N-Female	Bulkhead inline (no bracket)	1.3:1	Surge: 10kA IEC 61000-4-5 8/20as waveform

Part F – Quick Reference Guide

Introduction

Welcome to the quick reference guide for the Q data radios. This guide provides general information on the physical attributes of the Q data radios including, physical dimensions, mounting guides, LED indications and physical interface connections.

Half Duplex Radio - QR150

Typical Radio Setup

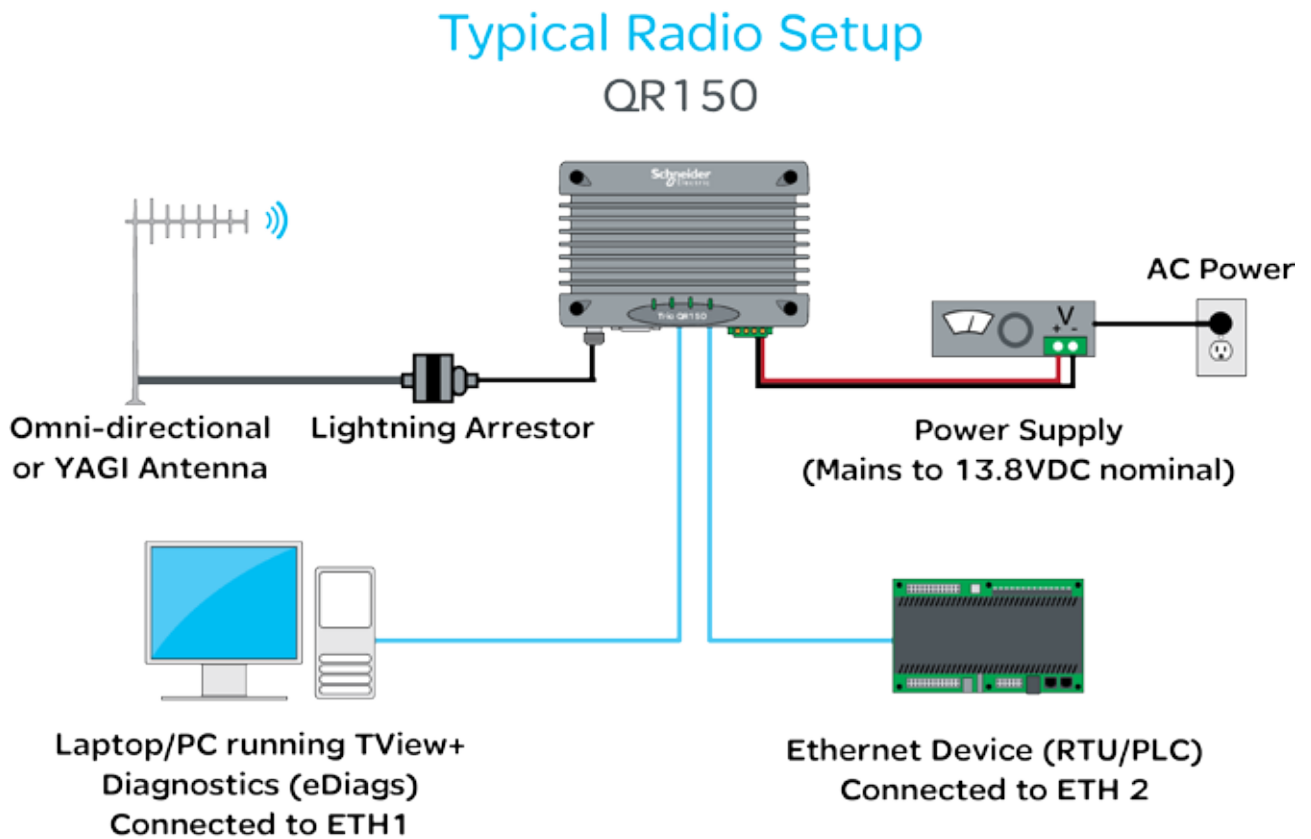

Schneider Electric offers a variety of wireless accessories, for further information, refer to the wireless accessories data sheet.

Mounting Instructions

Mount the radio in a clean and dry location, protected from water, excessive dust, corrosive fumes, extremes of temperature and direct sunlight. In high power or high temperature applications, allow sufficient passive or active ventilation. To help minimize moisture ingress it is suggested to mount the radio with the connectors facing downwards.

When mounting the equipment, consideration should be given to the environmental aspects of the site. The cabinet should be positioned so that it is shaded from potential high temperature of the afternoon sun, or icy cold wind. Although the radios are designed for harsh temperature extremes, they will give a longer service life if operated in a more stable temperature environment.

In an industrial environment, the radio modems should be isolated from excessive vibration, which can destroy electronic components, joints, and crystals. The cabinet should provide full protection from moisture, dust, corrosive atmospheres, and residue from ants and small vermin (which can be corrosive or conductive). The radio modem will radiate heat from the in-built heat sink, and the higher the transmitter duty cycle, the more heat will be radiated. Provide sufficient ventilation in the form of passive or forced air circulation to help ensure that the radio is able to maintain quoted temperature limits.

The QR150 is designed with four mounting holes to allow a flat mount of the radio. Each QR150 comes standard with four 16mm x 40mm self drilling screws. The heads of these screws are low profile wafer heads with a no. 2 Phillips recess.

Physical Dimensions

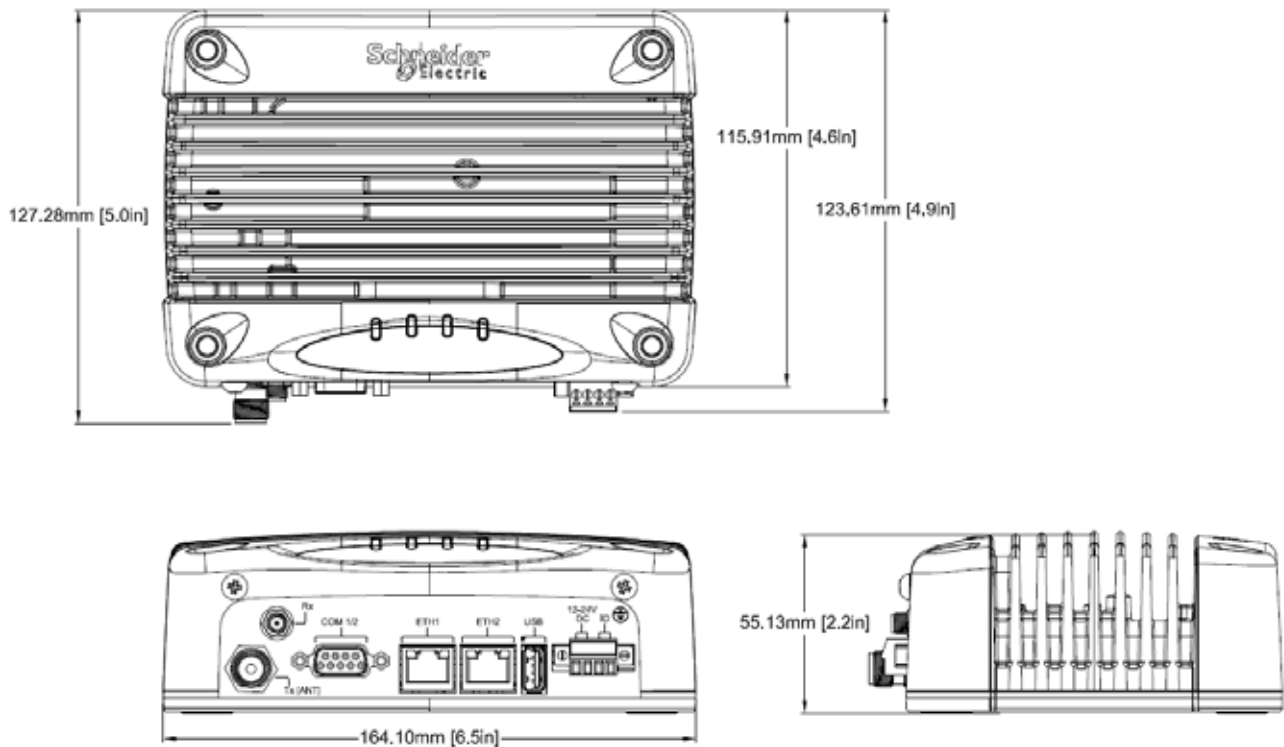

DIN rail mounting kit

An optional DIN rail mounting kit is available for the QR150. The mount is screwed onto the bottom of the QR150 giving the unit the ability to be simply 'clipped' and locked onto a 7.5 mm by 35 mm (0.3 in. by 1.4 in.) DIN rail.

Each DIN rail kit supplies:

- x1 DIN rail mounting bracket
- x1 DIN rail clip
- x4 Countersunk M4X8 screws (to mount DIN rail clip to bracket)
- x4 M4 nuts (to mount DIN rail clip to bracket)
- x4 Pan head M3X6 screws (to mount spread-spectrum radio to bracket)
- x4 Pan head M4X2.5 screws (to mount M-Series to bracket)
- x4 Pan head M4X8 screws (to mount QR150/QR450 to bracket)

DIN rail mounting bracket

Drawings not to scale.

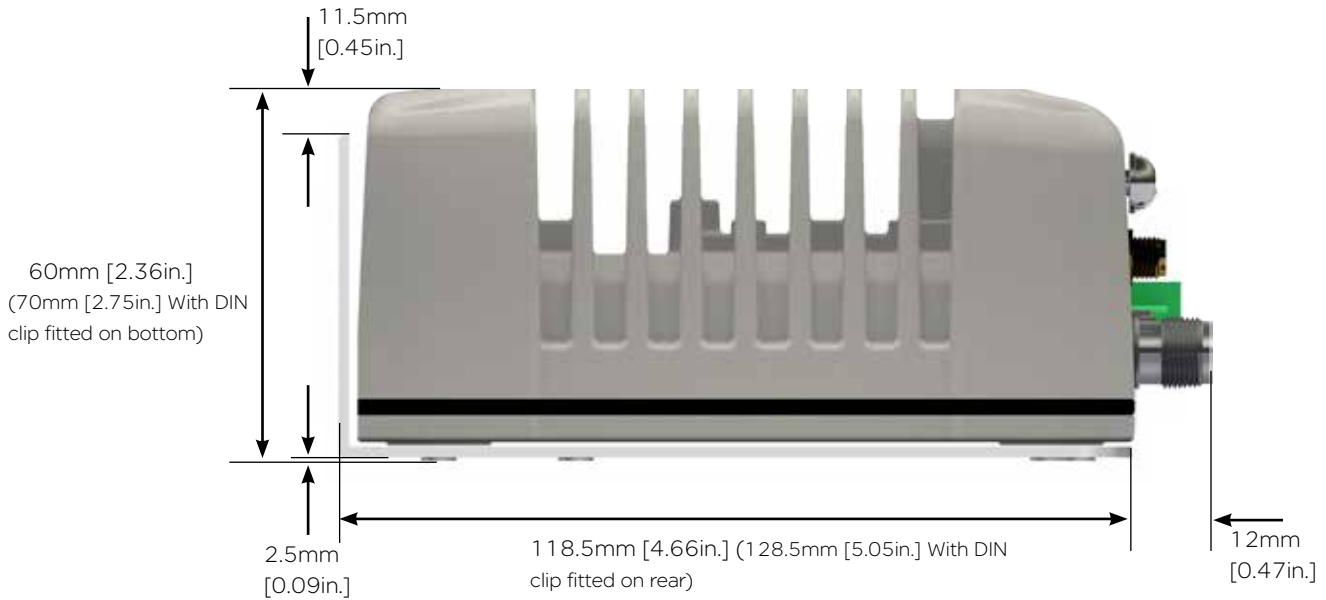

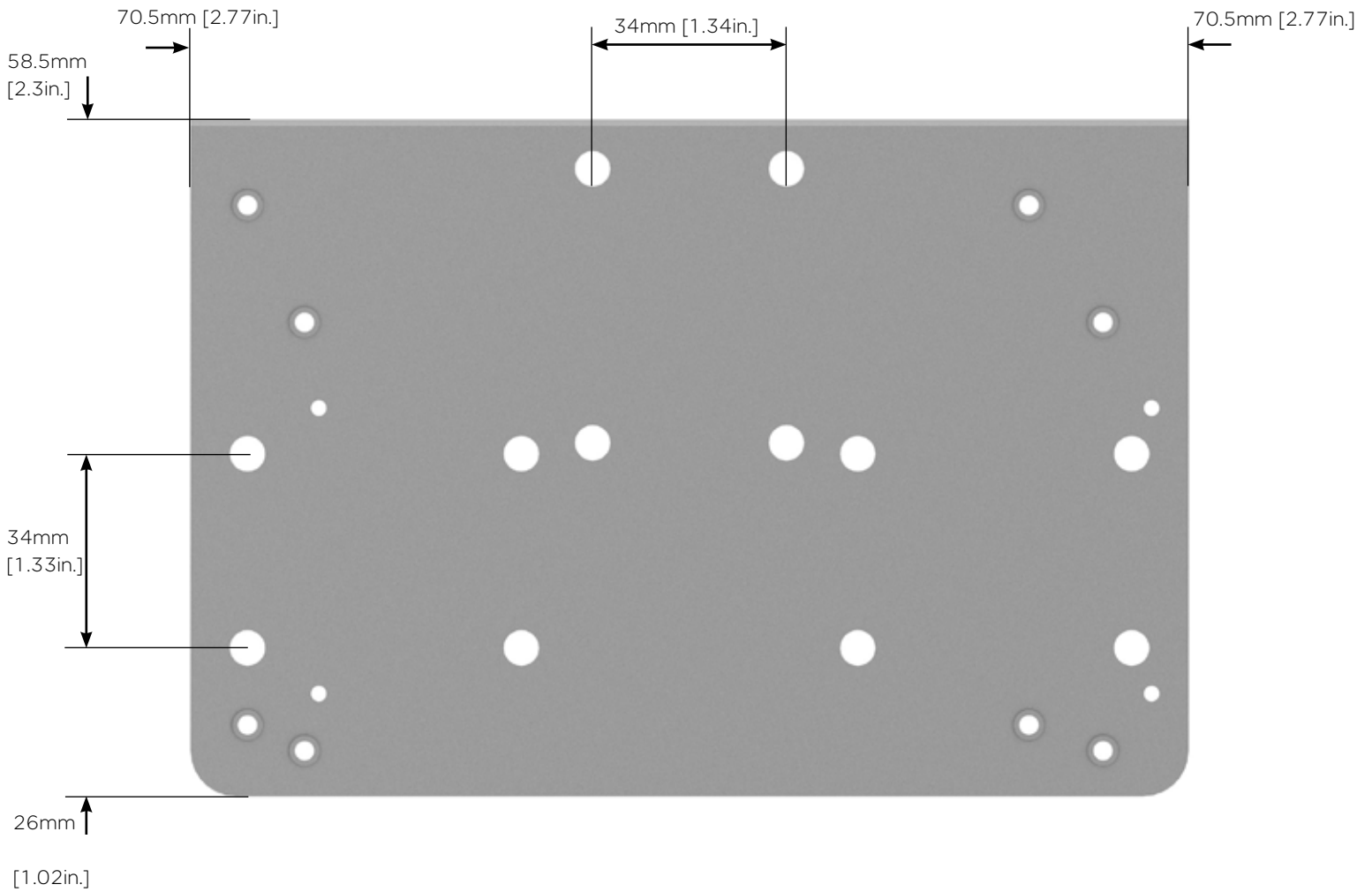
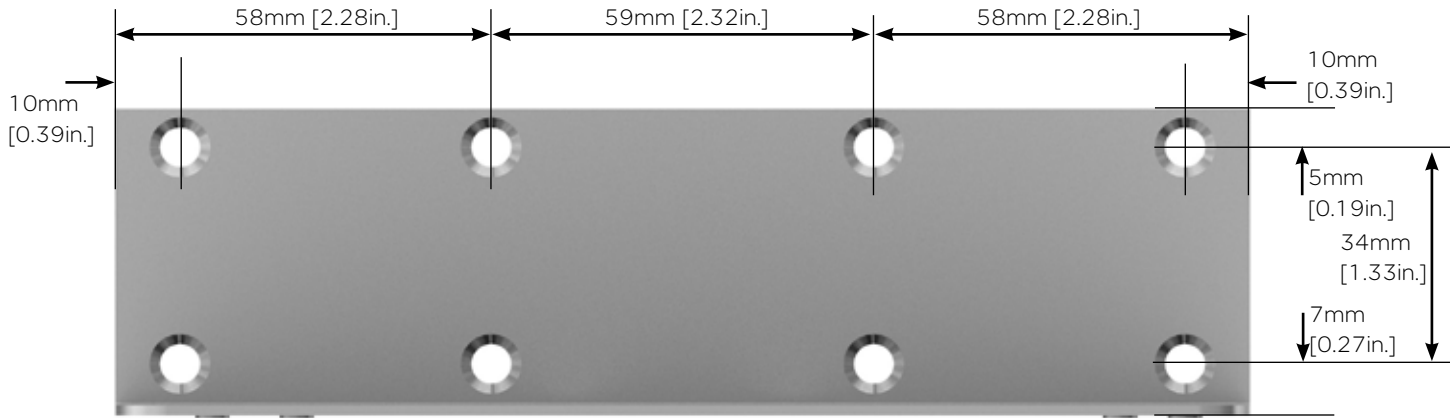

DIN rail clip

The DIN rail clip has a spring loaded latch to allow easy installation/removal of the radio device being installed.

The DIN rail clip can be fitted to the DIN rail mounting bracket x5 different ways to allow as much installation flexibility as possible.

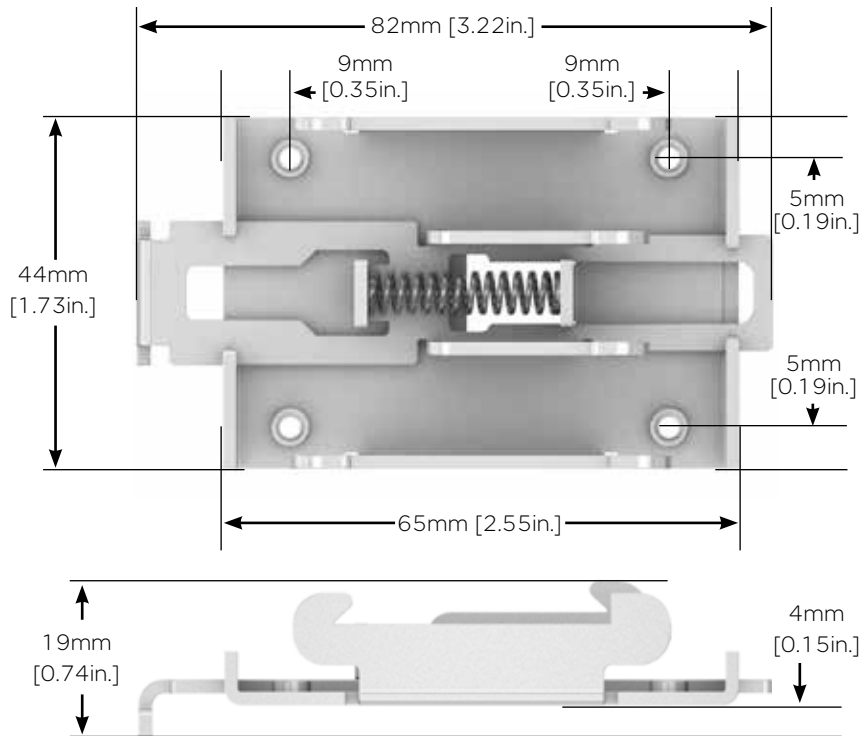

Rear mount DIN rail clip

The DIN rail clip can be fitted on the rear of the DIN rail mounting bracket two ways shown below.

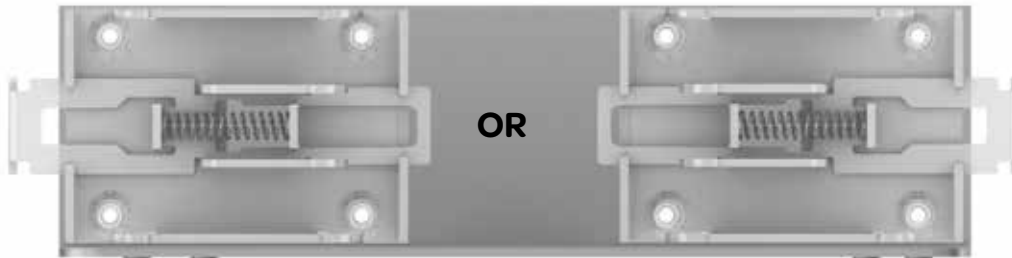

Examples of rear-fitted DIN clips:



Bottom mount DIN rail clip

The DIN rail clip can be fitted on the bottom of the DIN rail mounting bracket three different ways shown below.

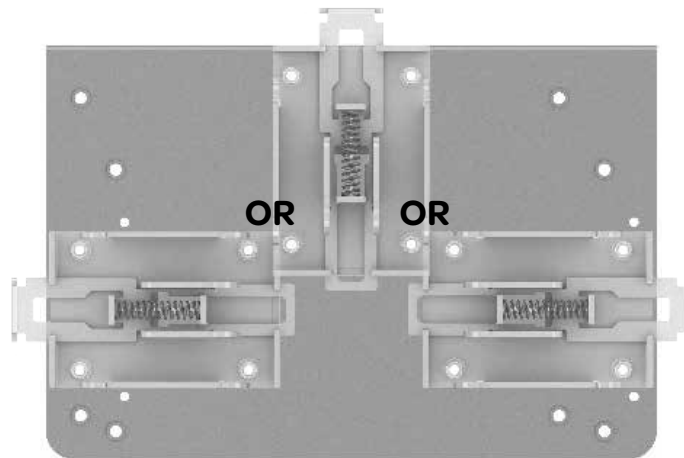

Examples of bottom-fitted DIN clips:



Power Supply Requirements

Rated Operating Voltage: 10...30 Vdc

Nominal Operating Voltage: 12 Vdc and 24 Vdc

Input Power (Rx typical): 5 W

Input Power (Tx typical): (See table below)

Tx Power (dBm)	Typical Input Power (Watts)
30	18
37	28
40	39

Typical receive/standby input power is 5 Watts. The input power will vary in transmit mode according to RF output power level.

The QR is supplied with a lock-in mating DC power connector (Schneider Electric Part Number TBUMPWR-PLUG-QR-A) which should be installed with the locking screws done up tightly (0.5 - 0.6 Nm / 4.42 - 5.31 ftin).

The radio is designed to limit damage if the voltage exceeds 30 Vdc or if reverse polarity is applied. The field-replaceable internal fuse has a 7 Amp rating. Fuse replacement instructions can be found within this user manual. Fuses are available from Schnedier Electric, part number TBUMPWR-FUSE-QR.

NOTICE

HAZARD OF EQUIPMENT DAMAGE

The radio modem can be damaged if there is any potential difference between the chassis-ground, RS232 signal ground, power (-) input, or antenna coaxial shield. Before connecting any wiring, ensure that all components are earthed to a common ground point.

Failure to follow these instructions can result in equipment damage.

Connect and secure the antenna, Ethernet and serial connectors BEFORE applying power to the unit. Lastly, before inserting the power connector, re-check that the polarity and voltage is correct using a multimeter and check the power cable against the +/- label printed on the front panel of the radio.

Physical Interfaces

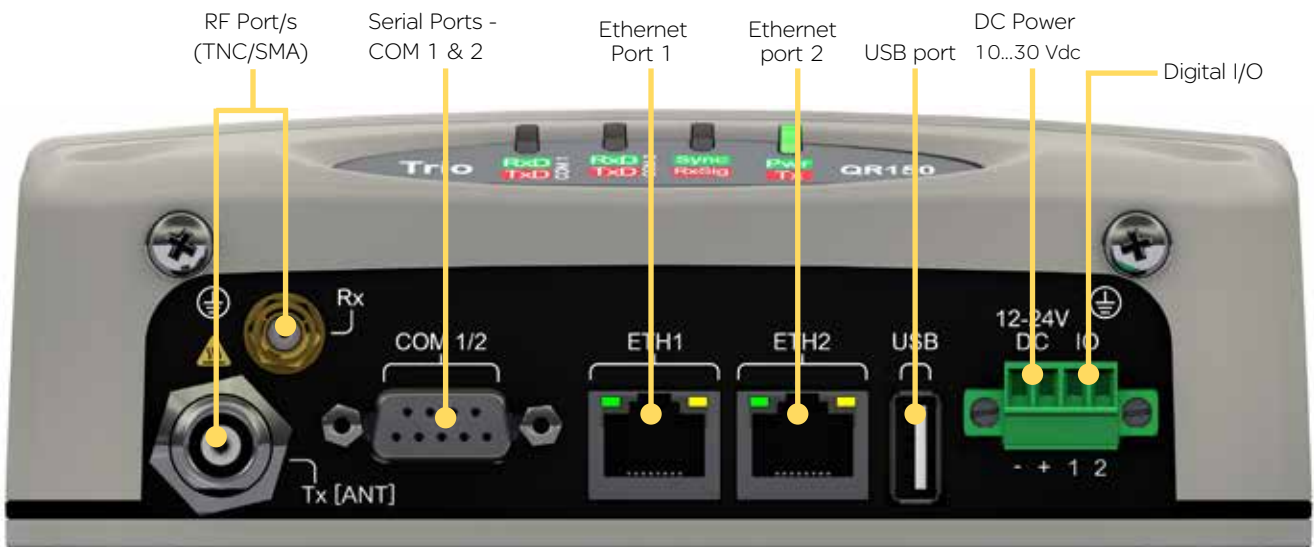

Half Duplex Radio - QR450

Typical Radio Setup

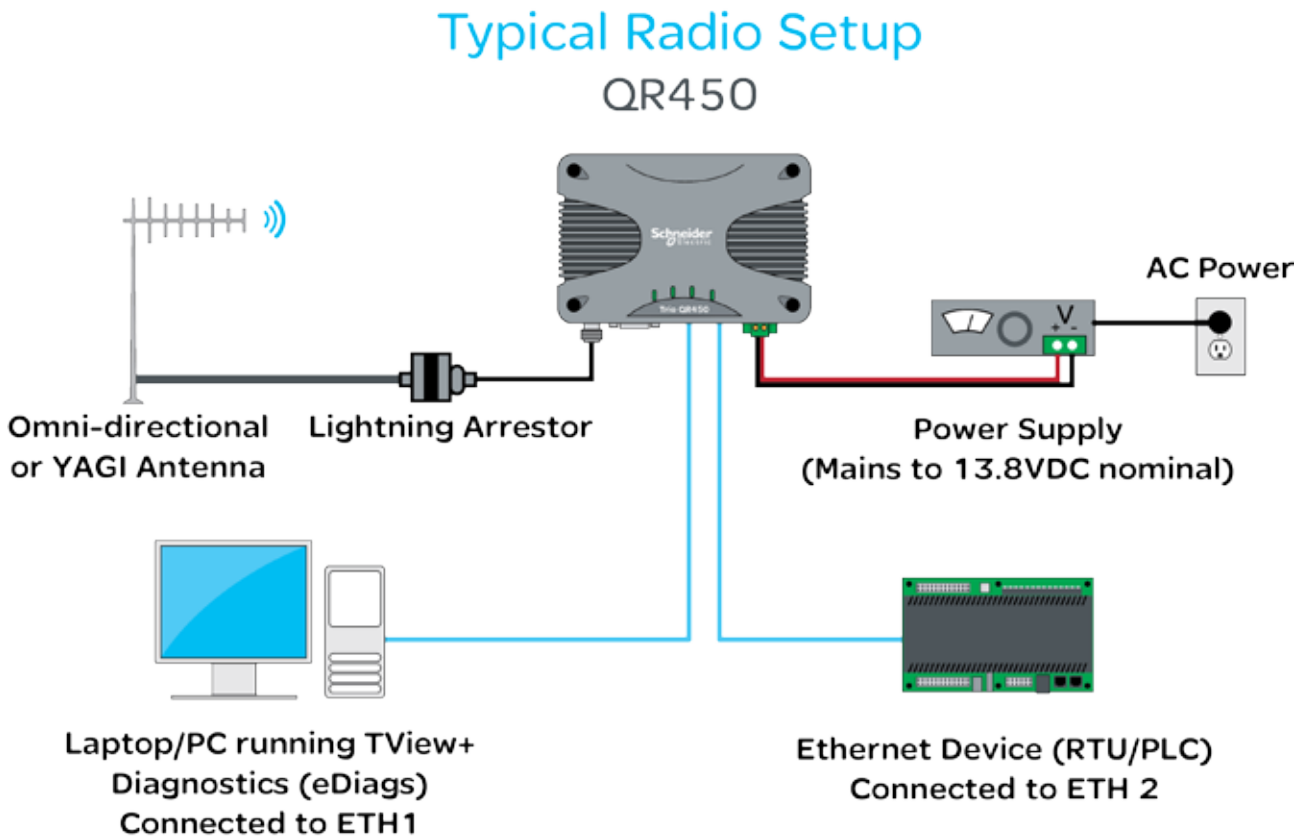

Schneider Electric offers a variety of wireless accessories, for further information, refer to the wireless accessories data sheet.

Mounting Instructions

Mount the radio in a clean and dry location, protected from water, excessive dust, corrosive fumes, extremes of temperature and direct sunlight. In high power or high temperature applications, allow sufficient passive or active ventilation. To avoid moisture ingress it is suggested to mount the radio with the connectors facing downwards.

When mounting the equipment, consideration should be given to the environmental aspects of the site. The cabinet should be positioned so that it is shaded from potential high temperature of the afternoon sun, or icy cold wind. Although the radios are designed for harsh temperature extremes, they will give a longer service life if operated in a more stable temperature environment.

In an industrial environment, the radio modems should be isolated from excessive vibration, which can destroy electronic components, joints, and crystals. The cabinet should provide full protection from moisture, dust, corrosive atmospheres, and residue from ants and small vermin (which can be corrosive or conductive). The radio modem will radiate heat from the in-built heat sink, and the higher the transmitter duty cycle, the more heat will be radiated from the heat sink. Ensure that there is sufficient ventilation in the form of passive or forced air circulation to help ensure that the radio is able to maintain quoted temperature limits.

The QR450 is designed with four mounting holes to allow a flat mount of the radio. Each QR450 comes standard with four 1.6mm x 40mm self drilling screws. The heads of these screws are low profile wafer heads with a no. 2 Phillips recess.

Physical Dimensions

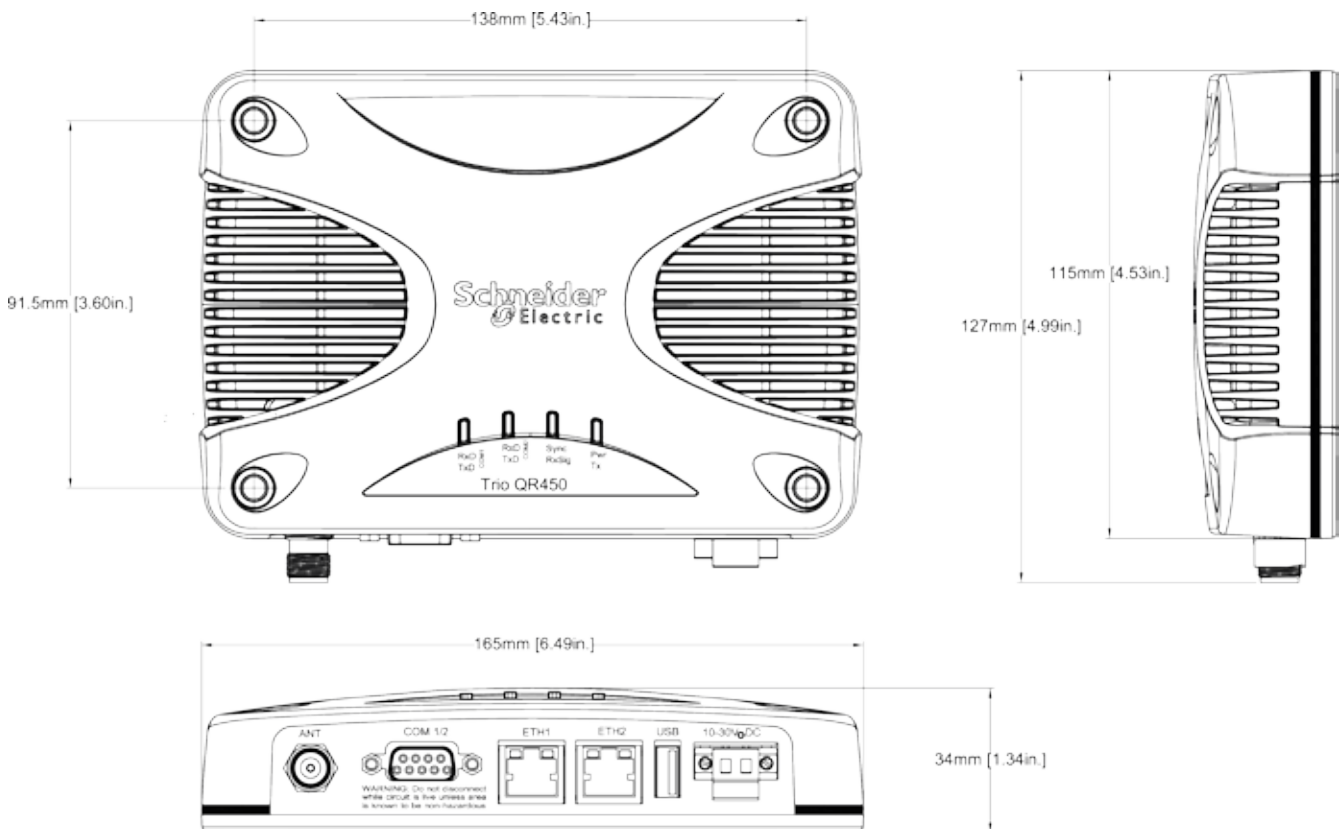

Drawings not to scale.

DIN rail mounting kit

An optional DIN rail mounting kit is available for the QR450. The mount is screwed onto the bottom of the QR450 giving the unit the ability to be simply ‘clipped’ and locked onto a 7.5 mm by 35 mm (0.3 in. by 1.4 in.) DIN rail.

Each DIN rail kit supplies:

- A DIN rail mounting bracket
- A DIN rail clip
- x4 Countersunk M4X8 screws (to mount DIN rail clip to bracket)
- x4 M4 nuts (to mount DIN rail clip to bracket)
- x4 Pan head M3X6 screws (to mount Spread spectrum radio to bracket)
- x4 Pan head M4X2.5 screws (to mount M-Series to bracket)
- x4 Pan head M4X8 screws (to mount QR150/QR450 to bracket)

DIN rail mounting bracket

Drawings not to scale.

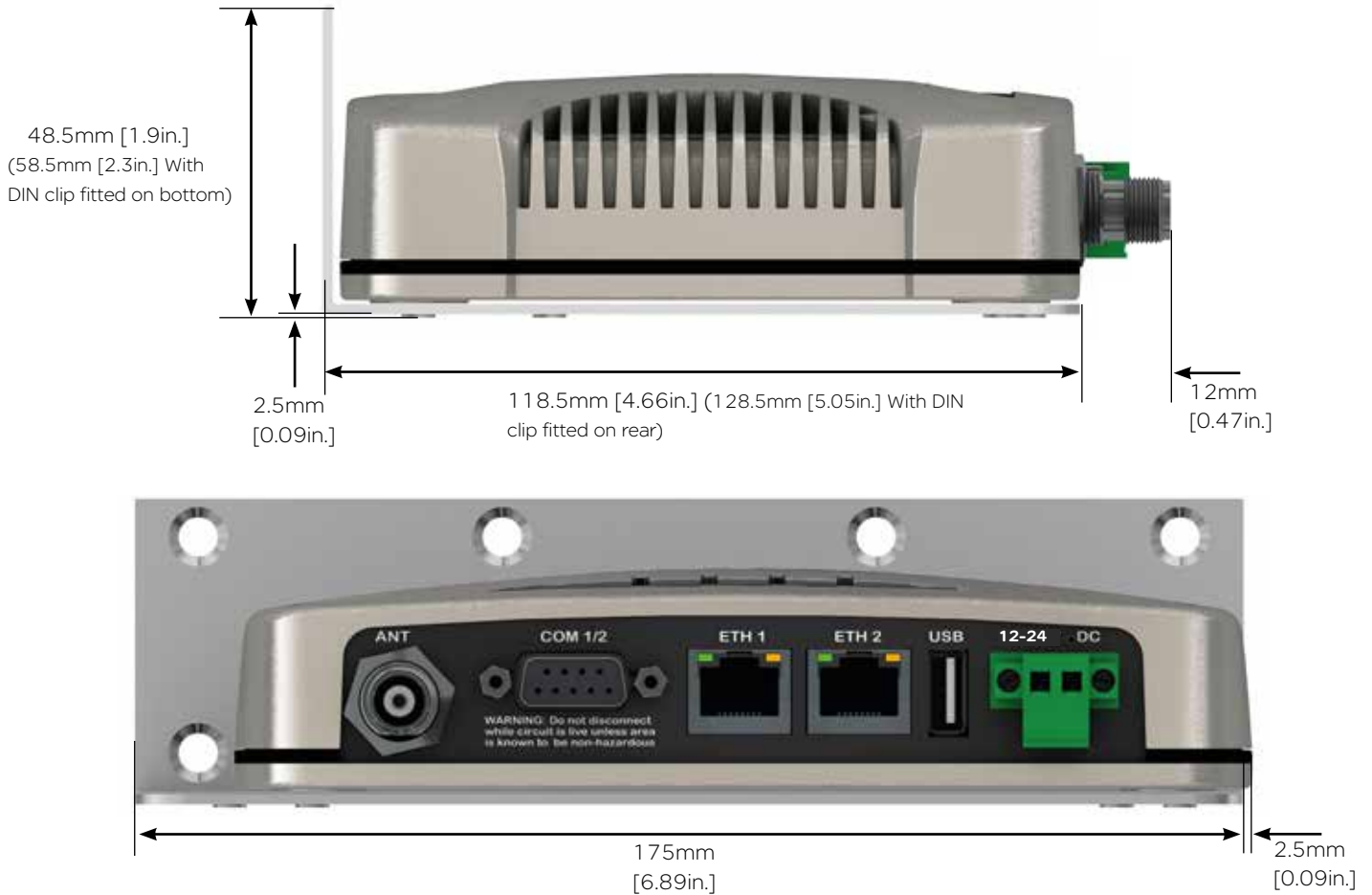

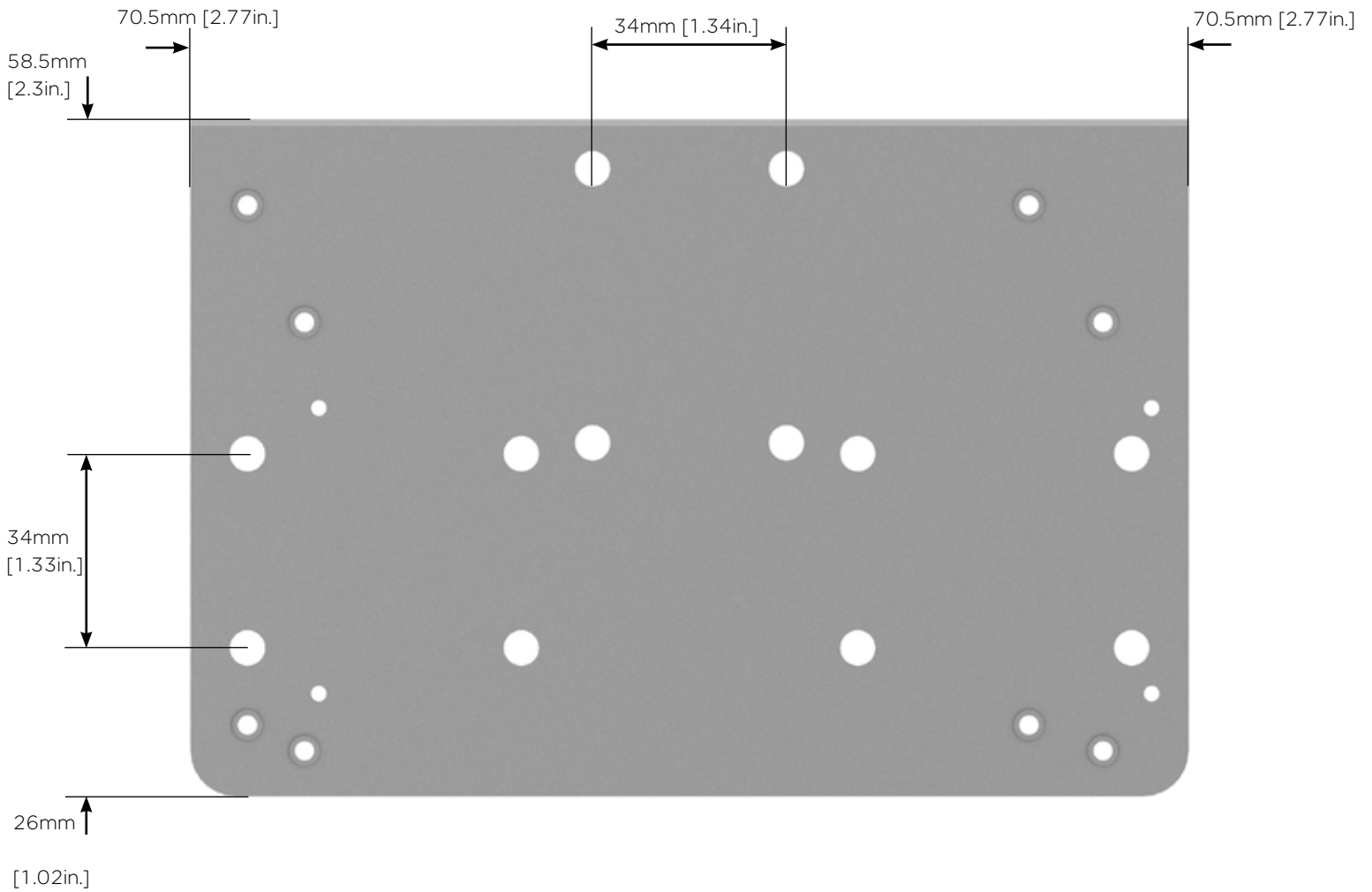
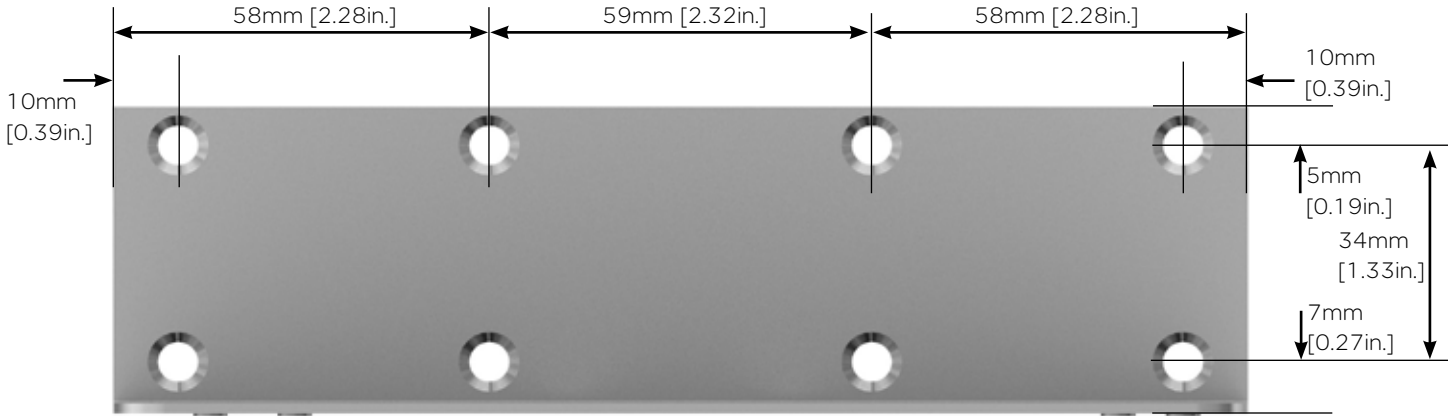

DIN rail clip

The DIN rail clip has a spring loaded latch to allow easy installation/removal of the radio device being installed.

The DIN rail clip can be fitted to the DIN rail mounting bracket x5 different ways to allow as much installation flexibility as possible.

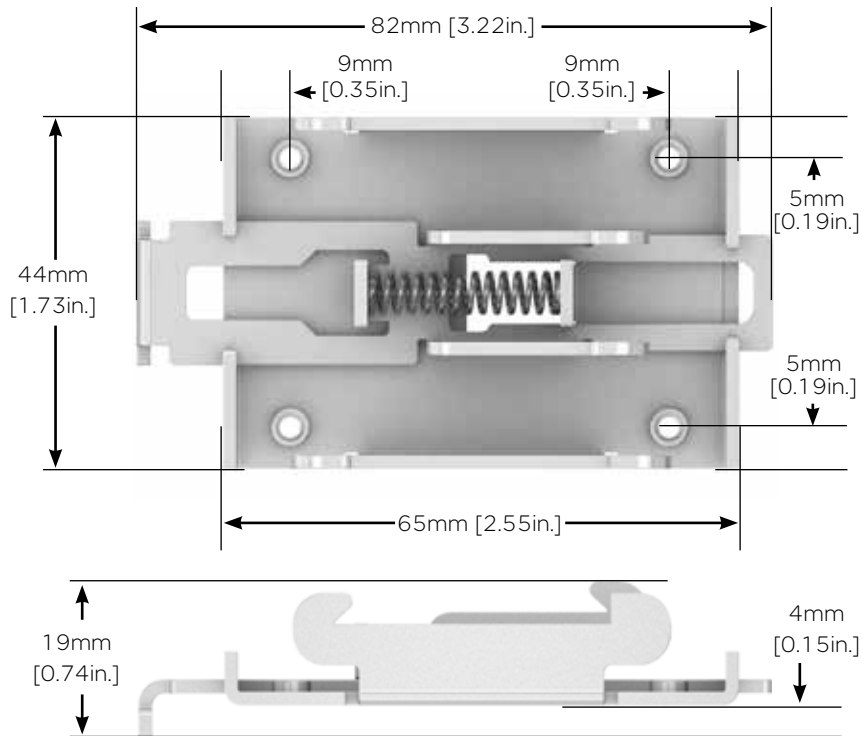

Rear mount DIN rail clip

The DIN rail clip can be fitted on the rear of the DIN rail mounting bracket two ways shown below.

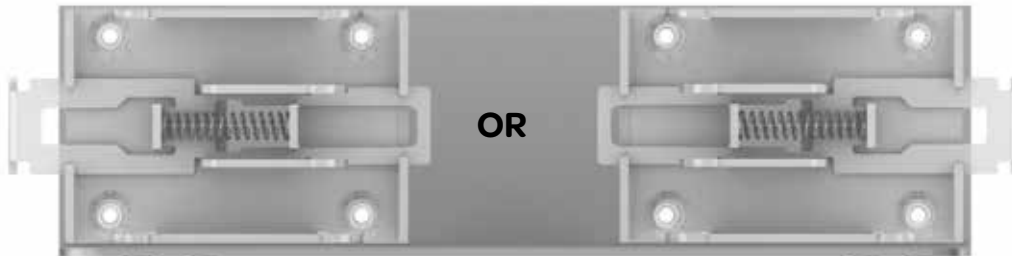

Examples of rear fitted DIN clips:



Bottom mount DIN rail clip

The DIN rail clip can be fitted on the bottom of the DIN rail mounting bracket three different ways shown below.

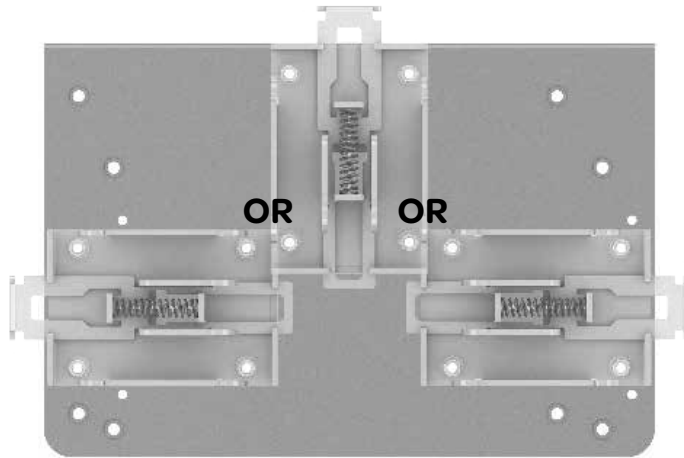

Examples of bottom fitted DIN clips:

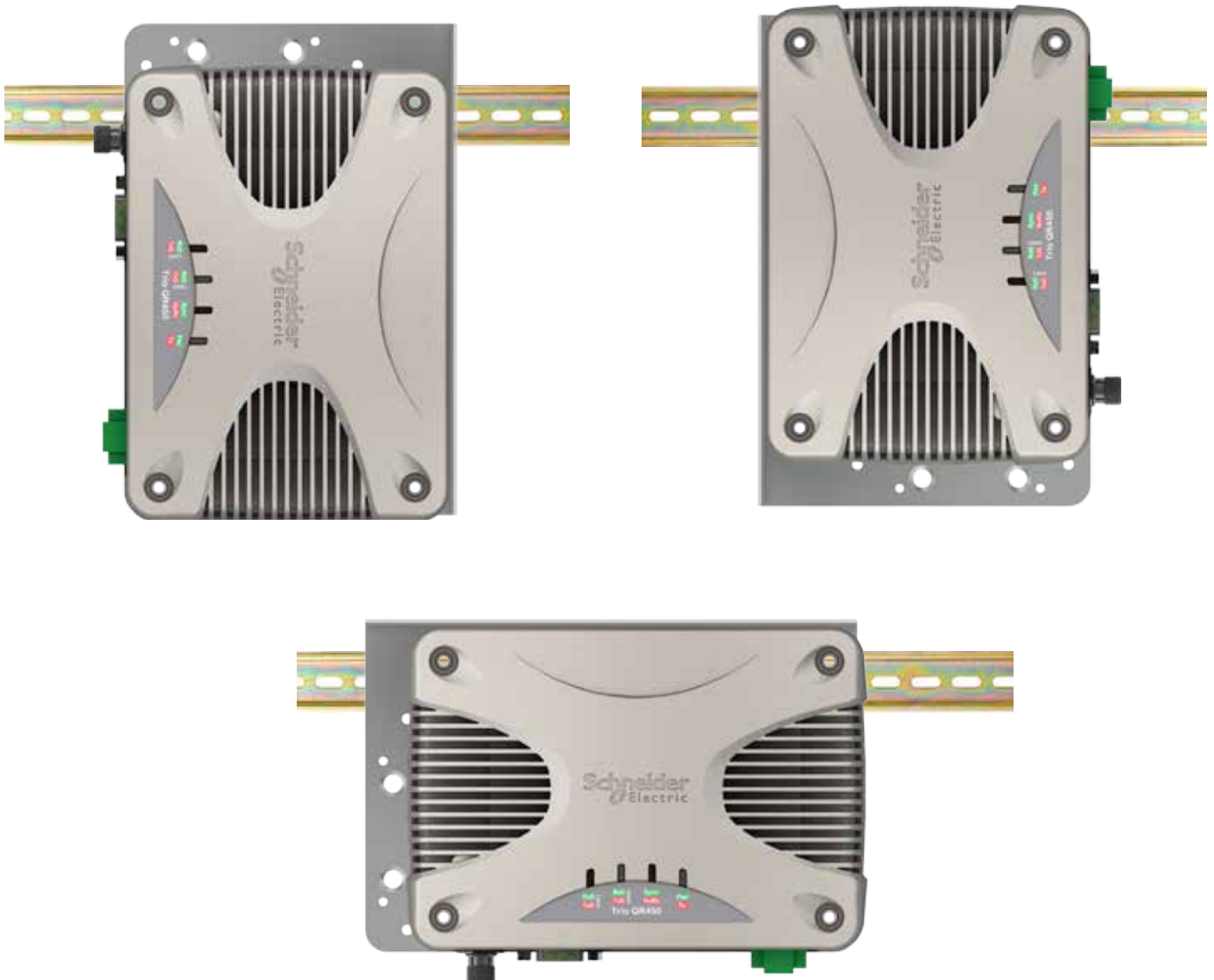

Power Supply Requirements

Rated Operating Voltage: 10...30 Vdc
 Nominal Operating voltage: 12 and 24 Vdc
 Input Power (Rx typical): 5 Watts
 Input Power (Tx typical): (See table below)

Tx Power (dBm)	Typical Input Power (Watts)
30	24
37	37
40	52

Typical receive/standby input power is 5 Watts. The input power will vary in transmit mode according to RF output power level.

The QR450 is supplied with a lock-in mating DC power connector (Schneider Electric Part Number TBUMPWR-PLUG-QR-A) which should be installed with the locking screws done up tightly (0.5 - 0.6 Nm / 4.42 - 5.31 ftin).

The radio is designed to limit damage if the voltage exceeds 30 Vdc or if reverse polarity is applied. The field-replaceable internal fuse has a 7 Amp rating. Fuses are available from Schnedier Electric, part number TBUMPWR-FUSE-QR. Fuse replacement instructions can be found within this user manual.

NOTICE

HAZARD OF EQUIPMENT DAMAGE

The radio modem can be damaged if there is any potential difference between the chassis-ground, RS232 signal ground, power (-) input, or antenna coaxial shield. Before connecting any wiring, ensure that all components are earthed to a common ground point.

Failure to follow these instructions can result in equipment damage.

Connect and secure the antenna, Ethernet and serial connectors BEFORE applying power to the unit. Lastly, before inserting the power connector, re-check that the polarity and voltage is correct using a multimeter and check the power cable against the +/- label printed on the front panel of the radio.

Physical Interfaces

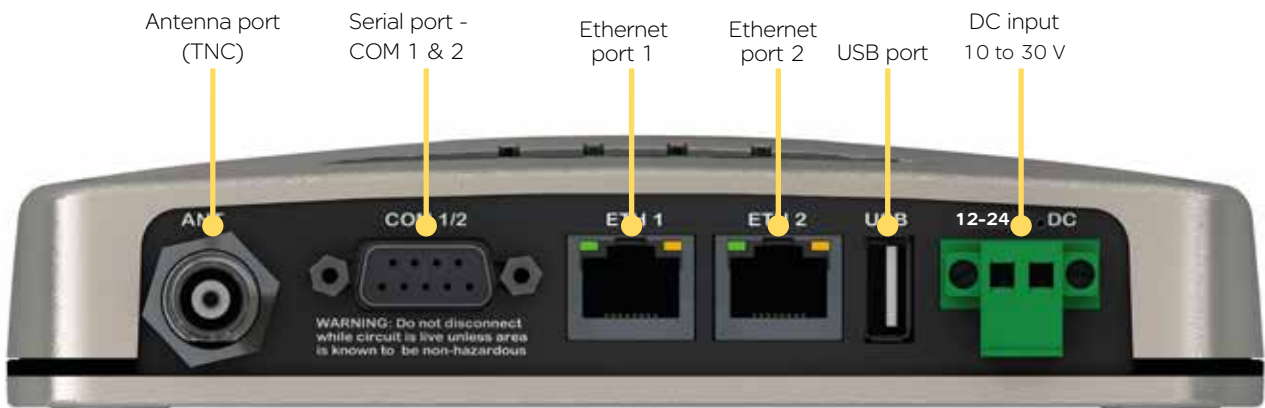

Full Duplex Radio - QB

Typical Radio Setup

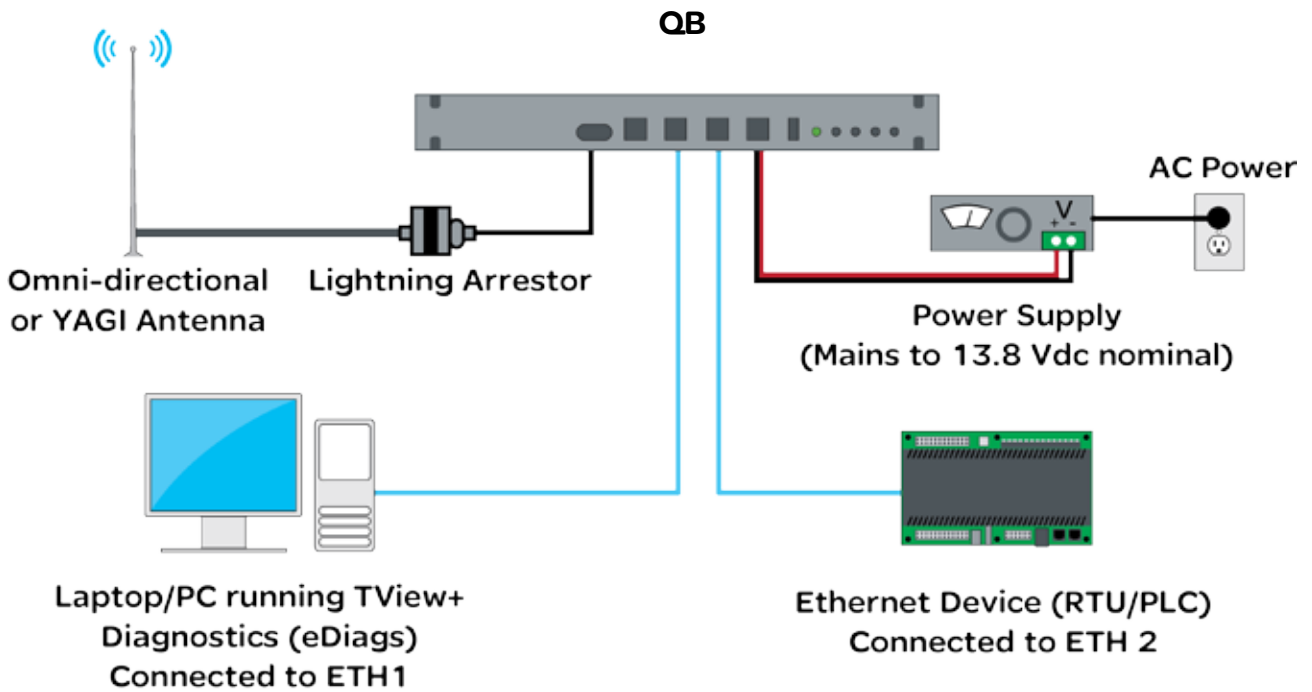

Schneider Electric offers a variety of wireless accessories, for further information, refer to the wireless accessories data sheet.

Mounting

The QB Full Duplex Radio is housed in a 1RU 19" rack enclosure. The radio is supplied with x2 1RU mounting brackets, which should be fitted to each side of the radio before it can be installed into a 19" rack. The mounting brackets can be fitted to the side of the radio in 3 different locations to provide different mounting capabilities: Front Mount, Proud Mount or Center Mount.



Front Mount

Fixing the mounting brackets for a front mount, allows the front of the radio to be flush with the front of a 19" rack.



Proud Mount

Fixing the mounting brackets for a proud mount, allows the front of the radio to slightly hang over the front of a 19" rack.



Center Mount

Fixing the mounting brackets for a center mount, allows the radio to be mounted into a 19" rack which contains a center pillar.

The radio should be mounted in a clean and dry location, protected from water, excessive dust, corrosive fumes, extremes of temperature and direct sunlight. Allow sufficient passive or active ventilation to allow the radio modem's heat sink to operate efficiently.

Antenna connections, Power connections and Digital I/O are all made at the rear of the unit.

All User ports, including; Serial Com ports, Ethernet ports, and Aux port are located on the front panel to provide easy access.

Physical Dimensions

19" (483mm) 1 RU rack mount.

Without mounting brackets, D:424 x H:44.45 x W:436.5mm (D:16.7" x H:1.75" x W:17.18")

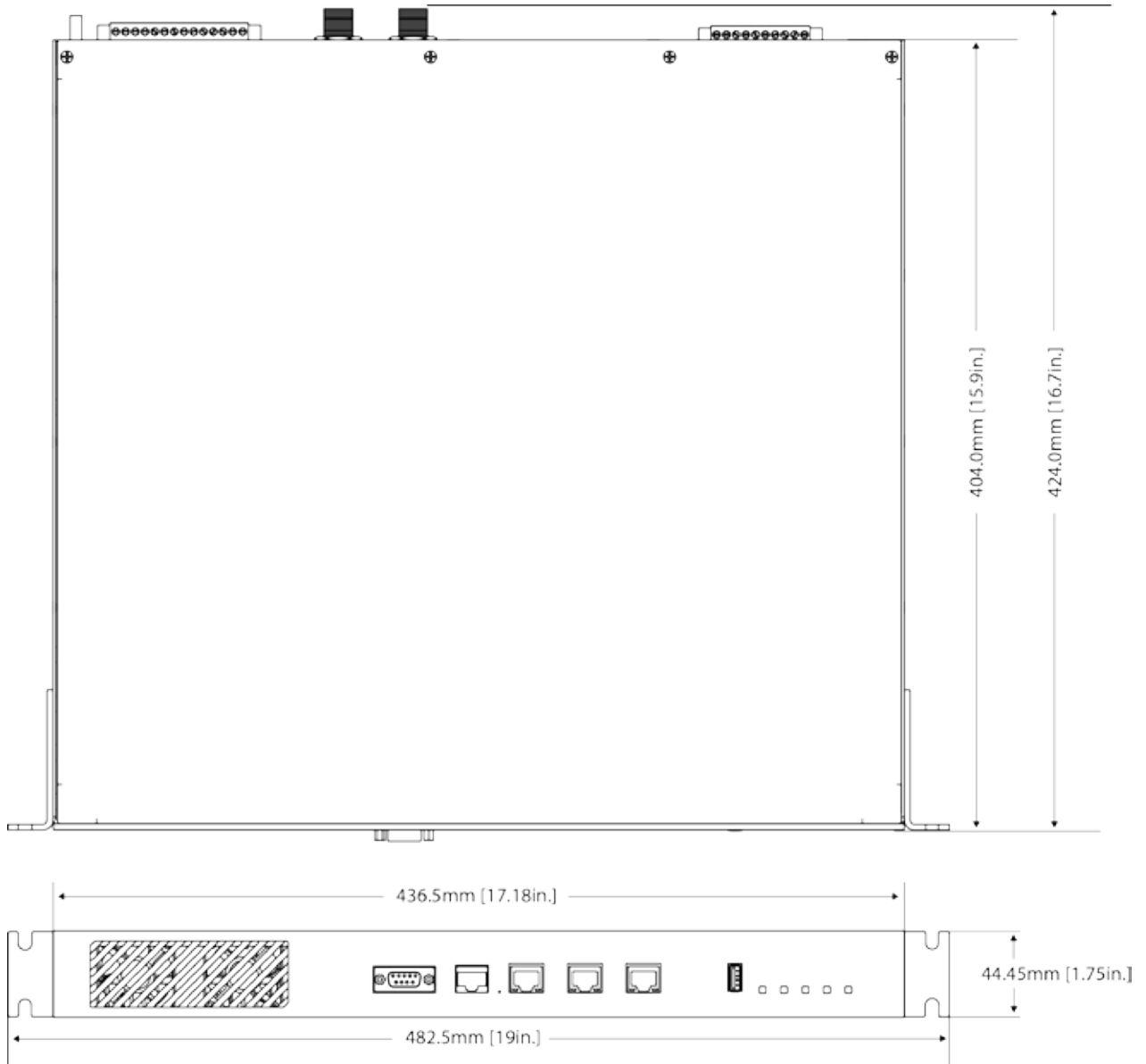

Drawings not to scale.

Power Supply Requirements

Operating Voltage: 11...30 Vdc (Dual Input)

Input Power (Rx typical): 14 Watts

Input Power (Tx typical): (See table below)

In high ambient temperature situations, the internal fans may operate, resulting in an increase of input power of up to 28 Watts.

Tx Power (dBm)	Typical Input Power (Watts)	
	QB150	QB450
30	26	34
37	38	46
40	46	59

Typical receive/standby input power is 14 Watts. The input power will vary in transmit mode according to RF output power level.

The QB is supplied with a lock-in mating DC power connector which should be installed with the locking screws done up tightly (0.5 - 0.6 Nm / 4.42 - 5.31 ftin). Replacement parts available from Schneider Electric, part number TBUMPWR-PLUG-QB.

The radio is designed to limit damage if the voltage exceeds the operating voltage or if reverse polarity is applied. The field replaceable internal fuse has a 12 Amp rating.

Replacement fuses available from Schneider Electric, part number TBUMPWR-FUSE-QB.

NOTICE	
HAZARD OF EQUIPMENT DAMAGE	
The radio modem can be damaged if there is any potential difference between the chassis-ground, RS232 signal ground, power (-) input, or antenna coaxial shield. Before connecting any wiring, ensure that all components are earthed to a common ground point.	
Failure to follow these instructions can result in equipment damage.	

Connect and secure the antenna, Ethernet and serial connectors BEFORE applying power to the unit. Lastly, before inserting the power connector, re-check that the polarity and voltage is correct using a multimeter and check the power cable against the +/- label printed on the rear panel of the radio.

Physical Interfaces

Front Panel

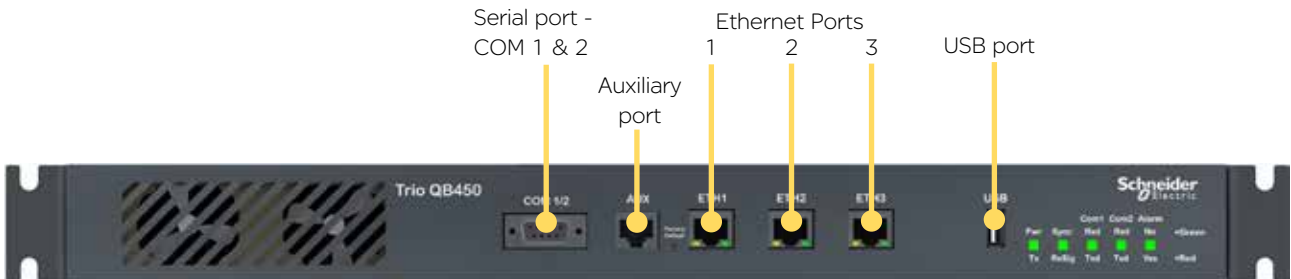

Rear Panel

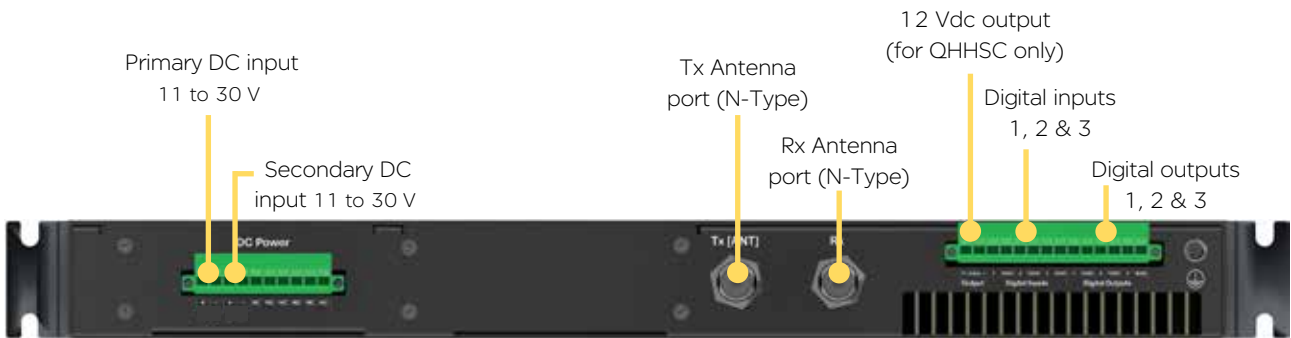

Hot Standby Half Duplex Radio - QP

Typical Radio Setup

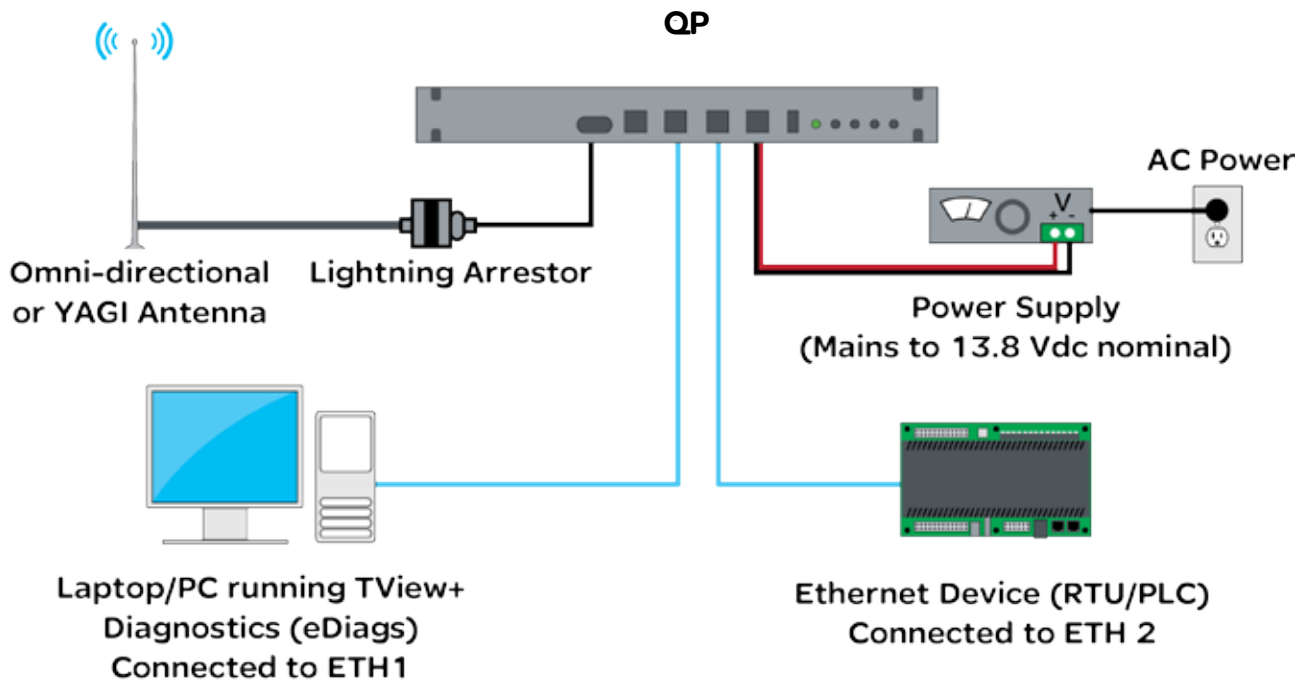

Schneider Electric offers a variety of wireless accessories, for further information, refer to the wireless accessories data sheet.

Operational Description

The QP hot standby half duplex radio, is a 1RU rack mounted module which operates with two internal highly reliable half duplex radios, which can be switched between to provide redundancy.

The two half duplex radios (Radio A & Radio B) operate simultaneously and depending on the QP antenna option, there are different antenna arrangements available:

- Option B: Duplicate Ports - This option provide a separate antenna port for each of the internal radios.
- Option D (QP150 only): Separate Switched Ports - This option provides a separate antenna port for the receiver, and the transmitter. Ownership of the ports will belong to the online remote, controlled by internal switching.
- Option E: Common Port - This option will connect the internal radio's antenna ports through an RF relay, providing a single antenna port on the QP.

Only data received by the "online" radio is directed to the user equipment. The online radio is also the only unit transmitting at any time. The QP can perform the following functions:

- Monitor the alarm output from both radio A and radio B and change over the online radio if required.
- Switch all user data through to the online radio.
- Switch the antenna via internal coaxial relay to the online radio transmitter (Requires QP Kit Option E).

Digital switching in the QP directs user data to and from the user ports on the front panel directly to the user ports of the online radio.

Mounting Guidelines

The QP hot standby half duplex radio is housed as a 1RU 19" rack mounted unit. There are mounting brackets included for the front panel, which can be used to secure the unit to the rack. The mounting brackets can be fitted to the side of each unit in 3 different locations to provide different mounting capabilities: Front Mount, Proud Mount or Center Mount. Refer to the QB Mounting guide for a graphical representation of the different mounting positions.

The unit should be mounted in a clean and dry location, protected from water, excessive dust, corrosive fumes, extremes of temperature and direct sunlight. Allow sufficient passive or active ventilation to allow the radio fans to pass air through the internal heat sink efficiently.

All RF, power and digital I/O connections are made at the rear of the unit. All User interfaces are located at the front of the unit, this includes: Ethernet interface, Serial COM port interfaces and Auxiliary interface.

Physical Dimensions

19" (483mm) 1 RU rack mount.

Without mounting brackets, D:424 x H:44.45 x W:436.5mm (D:16.7" x H:1.75" x W:17.18")

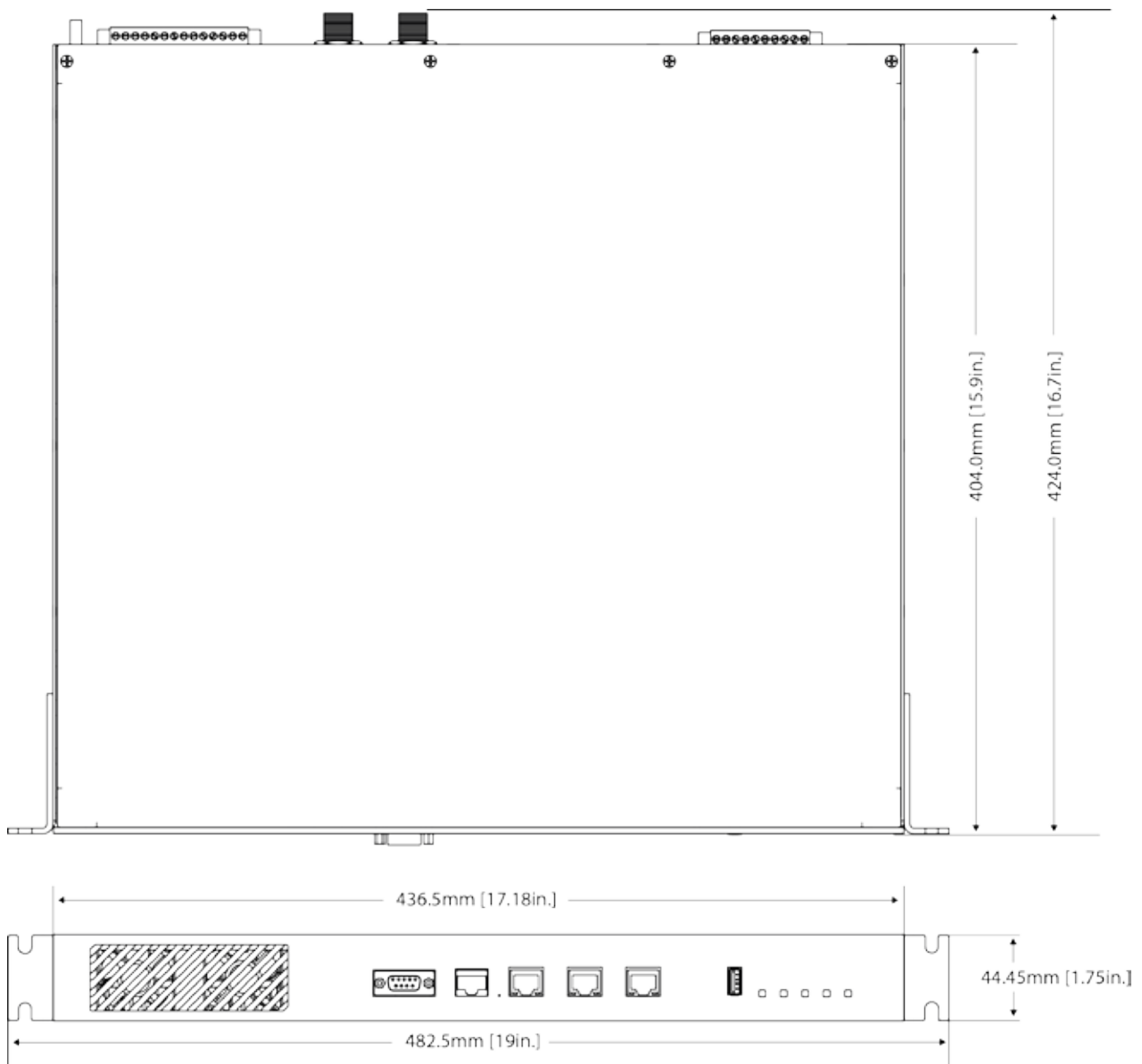

Power Supply Requirements

Operating Voltage: 11...30 Vdc (Dual Input)

Input Power (Rx typical): 14 Watts

Input Power (Tx typical): (See table below)

Tx Power (dBm)	Typical Input Power (Watts)	
	QP150	QP450
30	26	34
37	38	46
40	46	59

In high ambient temperature situations, the internal fans may operate, resulting in an increase of input power of up to 28 Watts.

Typical receive/standby input power is 14 Watts. The input power will vary in transmit mode according to RF output power level.

The QP is supplied with a lock-in mating DC power connector which should be installed with the locking screws done up tightly (0.5 - 0.6 Nm / 4.42 - 5.31 ftin). Replacement parts available from Schneider Electric, part number TBUMPWR-PLUG-QB.

The radio is designed to limit damage if the voltage exceeds the operating voltage or if reverse polarity is applied. The field-replaceable internal fuse has a 1.2 Amp rating. Replacement fuses available from Schneider Electric, part number TBUMPWR-FUSE-QB.

NOTICE	
HAZARD OF EQUIPMENT DAMAGE	
The radio modem can be damaged if there is any potential difference between the chassis-ground, RS232 signal ground, power (-) input, or antenna coaxial shield. Before connecting any wiring, ensure that all components are earthed to a common ground point.	
Failure to follow these instructions can result in equipment damage.	

Connect and secure the Antenna, Ethernet and Serial connectors BEFORE applying power to the unit. Lastly, before inserting the power connector, re-check that the polarity and voltage is correct using a multimeter and check the power cable against the +/- label printed on the rear panel of the radio.

IP Allocation

The internal half duplex radios have unique factory default IP addresses:

- Default IP Radio A: 192.168.2.15
- Default IP Radio B: 192.168.2.16

When configuring the QP, ensure that Radio A and Radio B have unique IP addresses to avoid IP conflicts.

Physical Interfaces

Front Panel

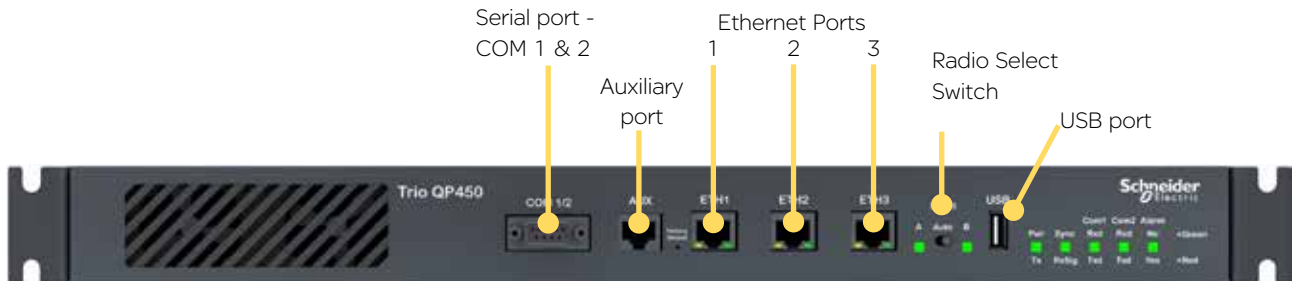

Radio Select Switch

The 3 position switch (A / Auto / B) on the front panel provides the following functionality:

- Position A: Radio A is forced online
- Position Auto: changeover hardware will select the online radio
- Position B: Radio B is forced online

Adjacent to the select switch are two LEDs: These LEDs indicate the current online radio.

Indicated State	Select LEDs
Auto Mode	
Local Force	
Remote Force	

Rear Panel (Hot Standby Option B)

Duplicated Antenna Ports

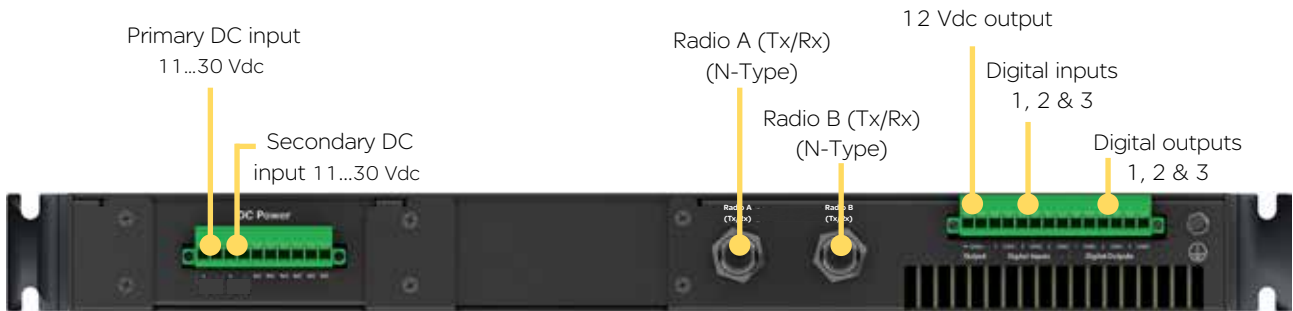

Rear Panel (Hot Standby Option D) - QP150 Only

Separate Switched Tx & Rx Ports

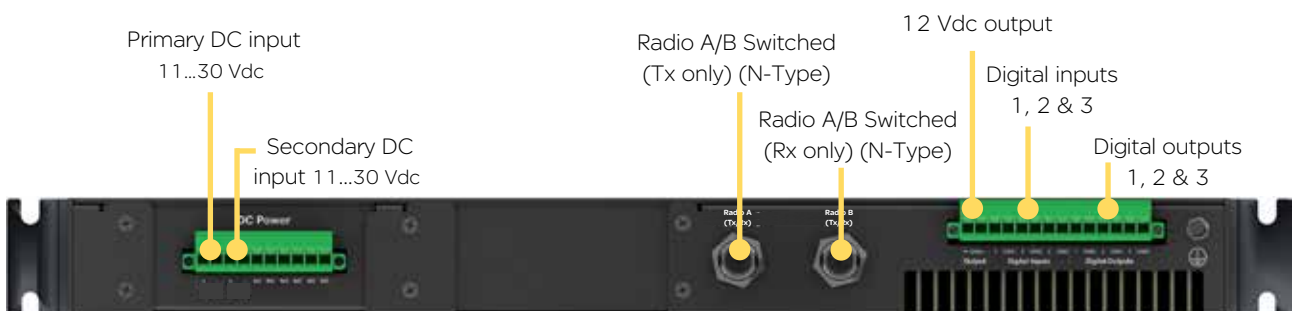

Rear Panel (Hot Standby Option E)

Common Switched Antenna Ports

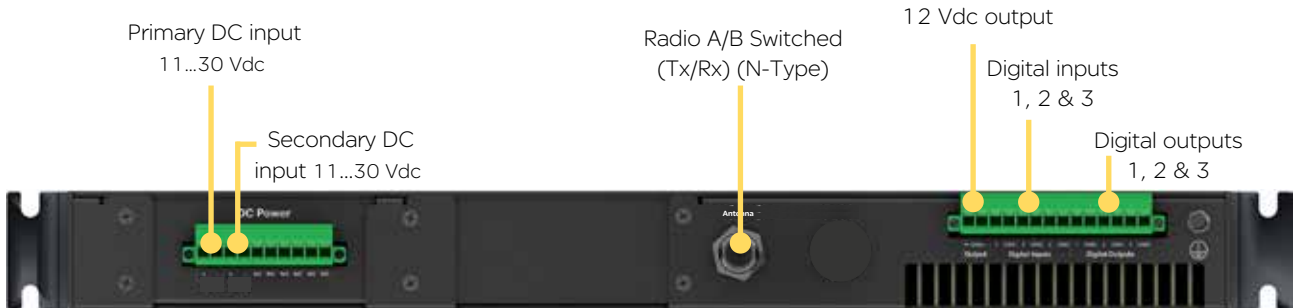

Hot Standby Full Duplex Radio - QH

Introduction

Welcome to the Quick Start Guide for the QH Hot Standby full duplex radio. This section provides additional installation considerations, wiring diagrams and operational descriptions. This document should be read in conjunction with the QB full duplex radio Quick Start Guide.

The QH is a redundant, hot standby, full duplex radio providing automatic changeover facilities.

The QH is designed as a modular solution, comprising 2 identical QB full duplex radios (standard) linked to a central monitoring and changeover controller (Hot Standby Controller). Either QB may be taken out for maintenance without the need for system down time. The automatic changeover can be triggered by the online out-of-tolerance (alarm) conditions based on either RF and/or user data throughput parameters.



Typical Radio Setup

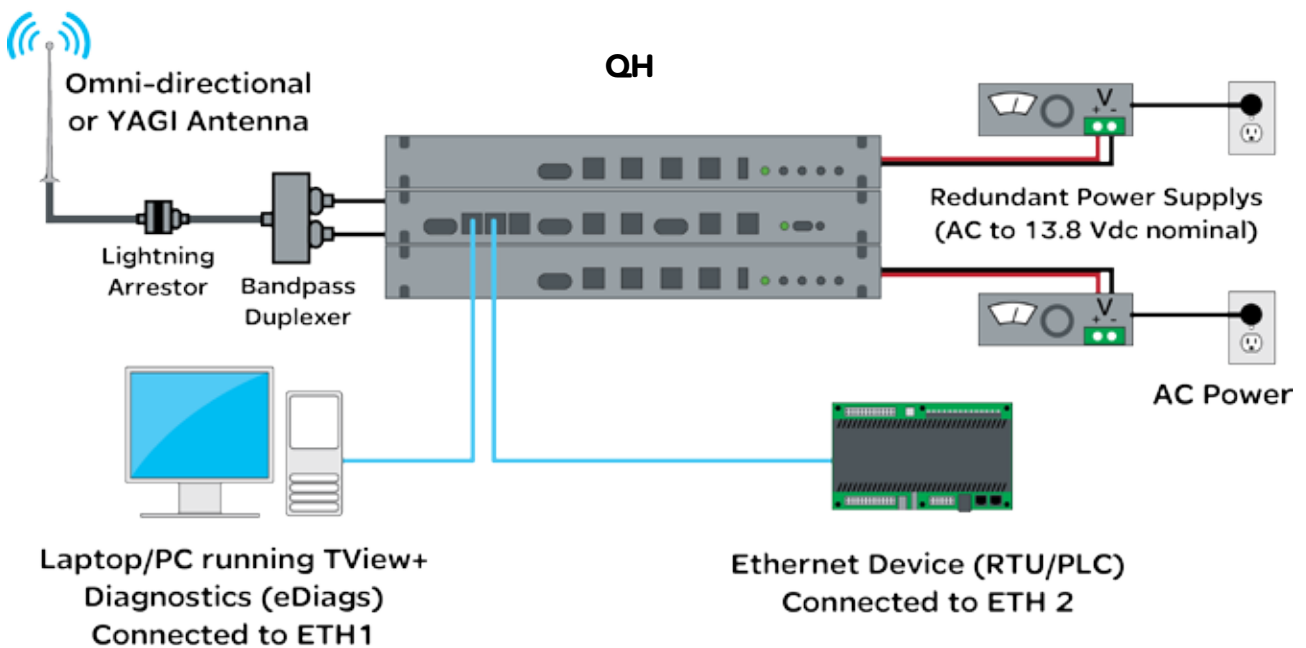

Schneider Electric offers a variety of wireless accessories, for further information, refer to the wireless accessories data sheet.

Operational Description

The QH Hot Standby Controller (QHHSC) unit is a 1RU rack-mounted module that interfaces to two independent full duplex radios (each 1 RU rack mounted modules) via a number of RF and data cables.

Both full duplex radios (Radio A & Radio B) operate simultaneously, constantly receiving radio signals. However only data from one radio (the "online" radio) is directed to the user equipment. The online radio is also the only unit transmitting at any time. The Hot Standby Controller provides the following functions:

- Amplify and split the incoming signal so both Radio A and Radio B receive simultaneously.
- Monitor the alarm output from both Radio A and Radio B and change over the online radio if required.
- Switch all user data through to the online radio.
- Switch the antenna, via internal coaxial relay, to the online radio transmitter (Requires QHHSC Kit Option A).

Digital switching in the QHHSC directs data to and from the user ports on the front panel directly to the user ports of the online radio.

The QHHSC and the two full duplex radios pass operational/alarm detection status between one another via the AUX interface. Any alarm detection indicated from the online radio can cause the QHHSC to change over the online radio.

Mounting

The QH hot standby full duplex radio is housed as a 3 RU 19 in. rack mounted set, encompassing two x 1 RU QB full duplex radios and one x 1 RU QH Hot Standby Controller. The Controller and full duplex radios are each supplied with two x 1 RU mounting brackets, are to be fitted to each sides of each unit before it can be installed into a 19 in. rack. The mounting brackets can be fitted to the side of each unit in 3 different locations to provide different mounting capabilities: Front Mount, Proud Mount or Center Mount. Refer to the QB Mounting guide for a graphical representation of the different mounting positions.

The unit should be mounted in a clean and dry location, protected from water, excessive dust, corrosive fumes, extremes of temperature and direct sunlight. Provide sufficient passive or active ventilation to allow the full duplex radio fans to pass air through the internal heat sink efficiently.

All RF, power and digital I/O connections are made at the rear of the unit. All user interfaces are located at the front of the unit, these include: Ethernet interface, Serial COM port interfaces and Auxiliary interfaces.

Power Supply Requirements

Operating Voltage: 11...30 Vdc (Dual Input)

Input Power (Rx typical): 35 Watts

Input Power (Tx typical): (See table below)

Tx Power (dBm)	Typical Input Power (Watts)	
	QH150	QH450
30	48	55
37	59	67
40	68	80

In high ambient temperature situations, the internal fans may operate, resulting in an increase of input power of up to 56 Watts [x2 QBs].

Typical receive/standby input power is 35 Watts. The input power will vary in transmit mode according to RF output power level.

Each QB within the hot standby arrangement is supplied with a lock-in mating DC power connector which should be installed with the locking screws done up tightly (0.5 - 0.6 Nm / 4.42 - 5.31 ftin). Replacement parts available from Schneider

Electric, part number TBUMPWR-PLUG-QB.

The radios are designed to limit damage if the voltage exceeds the operating voltage or if reverse polarity is applied. Each QB has a field-replaceable internal fuse with a 12 Amp rating. Replacement fuses available from Schneider Electric, part number TBUMPWR-FUSE-QB.

Physical Dimensions

Hot Standby is configured using 2 x QB full duplex radios + 1 x Hot Standby Controller (19 in. 1 RU each) for a total of 19 in. (483 mm) 3 RU rack mount.

Without mounting brackets, D:424 x H:133.3 x W:436.5 mm (D:16.7 x H:5.25 x W:17.18 in.)

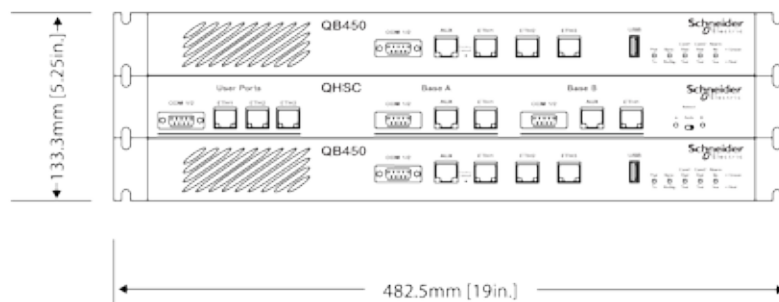
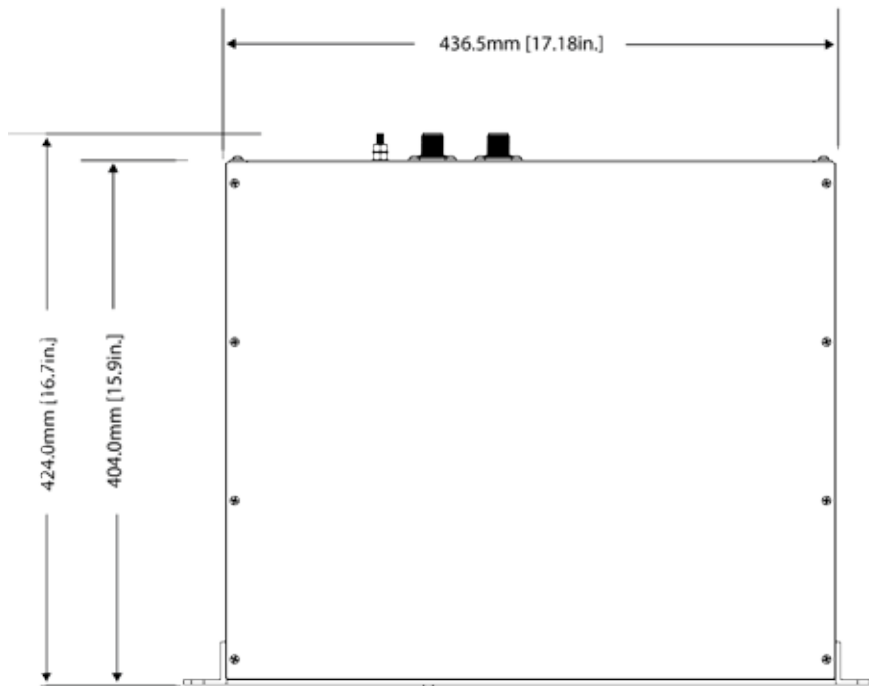

Radio Position Allocation

The QH is made up of three separate devices, a single QH hot standby controller and two separate QB full duplex radios. Within a hot standby arrangement, the two full duplex radios must be allocated a QH position, either Radio A or Radio B. The diagrams on the following pages use the radio position allocation shown below.



Communication Ports

There are multiple connections required between the front panel interfaces of the QH

- COM 1/2 (Both Radios to QHHSC)
- AUX (Both Radios to QHHSC)
- ETH 1 (Both Radios to QHHSC)
- ETH 3 (Between Radios A & B)

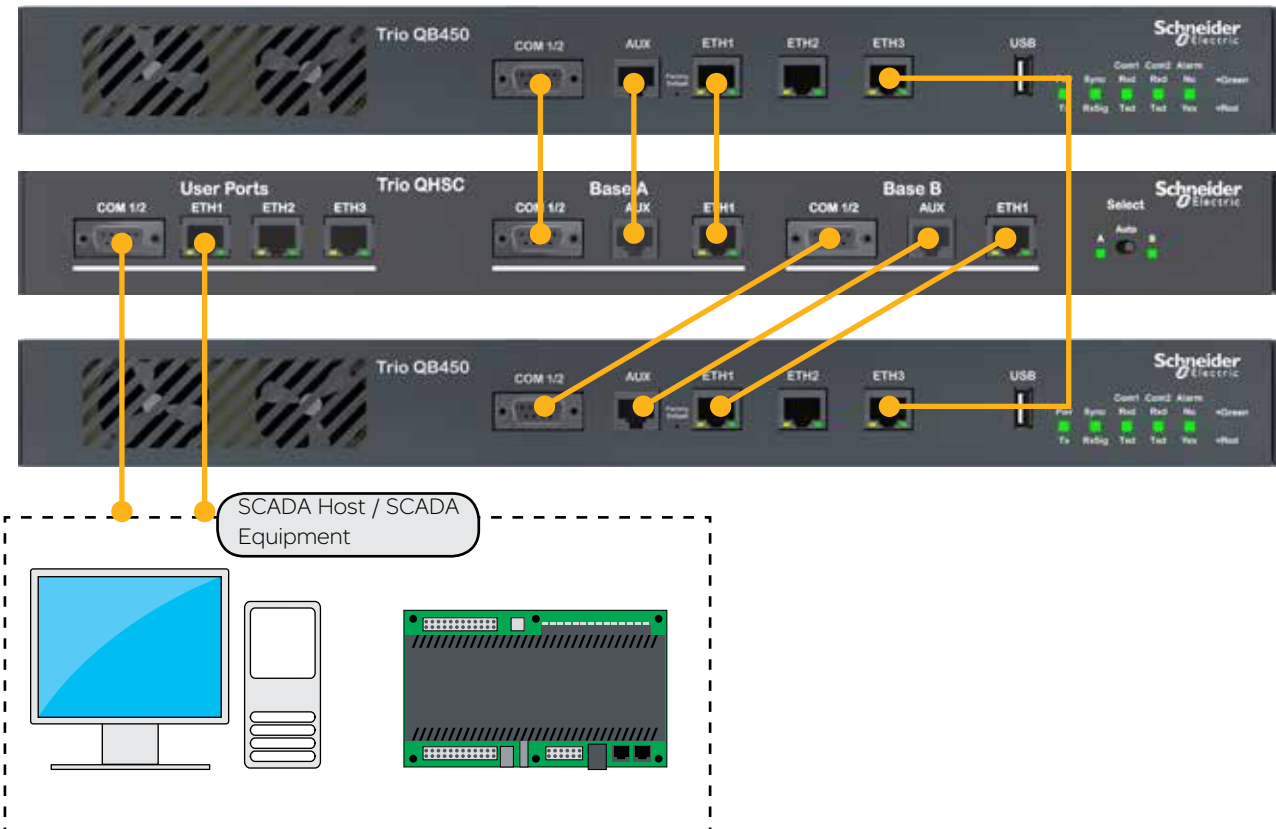

Power Supply and Protection

In order to provide power to this redundant, hot standby radio system, the QH supports dual power supplies. A separate power supply is used for each of the full duplex radios. To help increase reliability, the power supplies are crossed-over to each of the secondary supply inputs of the full duplex radios as shown in the diagram below.

Each full duplex radio has diode-ORed supply inputs, making a redundant power supply pair for each full duplex radio possible.

The Hot Standby Controller has connections for dual power supplies and is powered from the 12V DC output of the full duplex radios as shown in the diagram below.

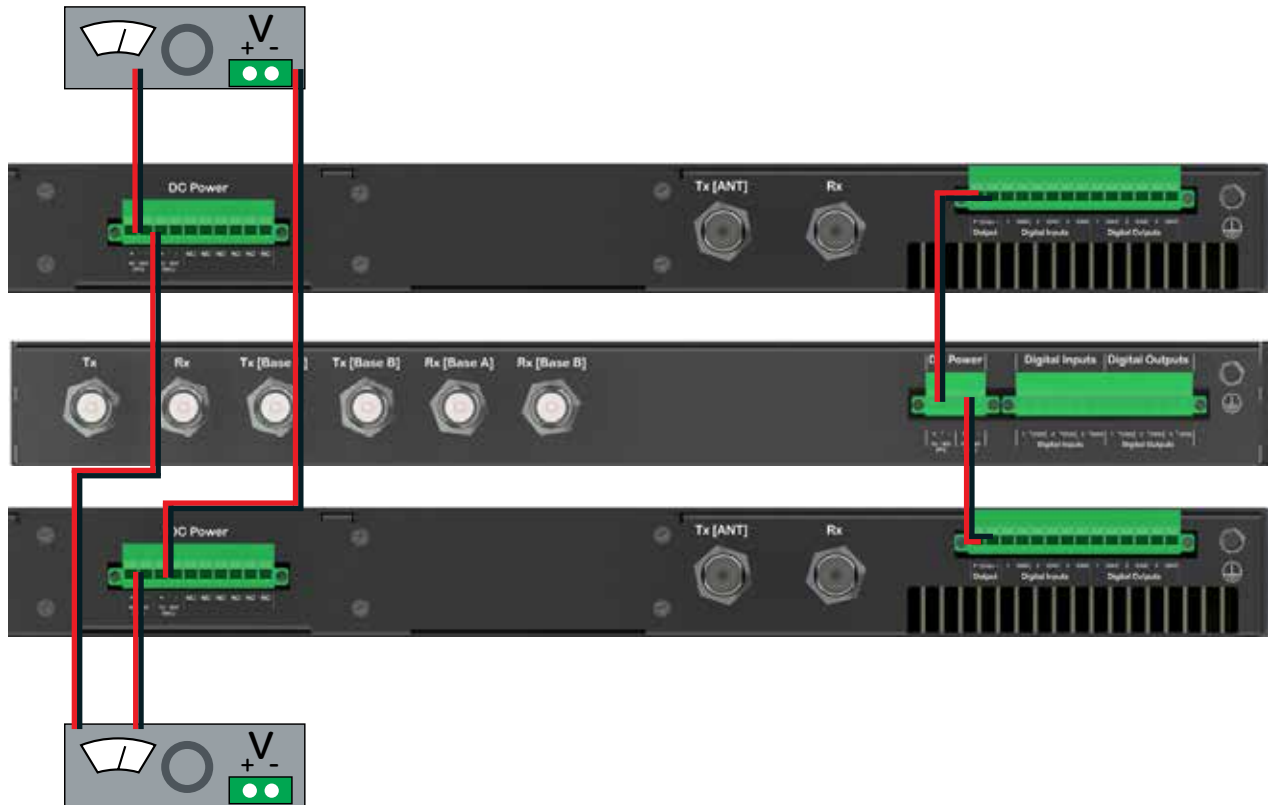

Antennas and RF Feeders

There are two primary antenna connection options. All connectors are standard N-Type sockets. See diagrams below.

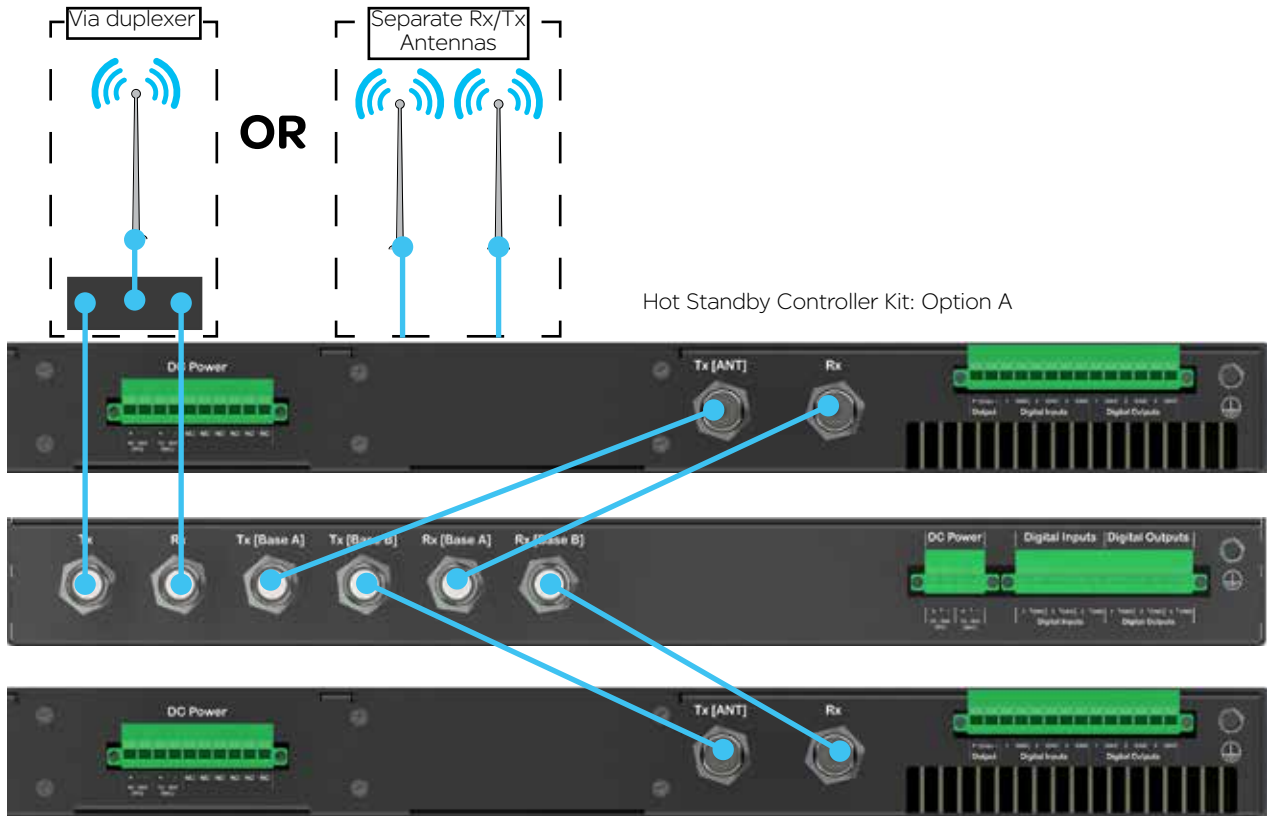

Hot Standby Controller Kit: Option A

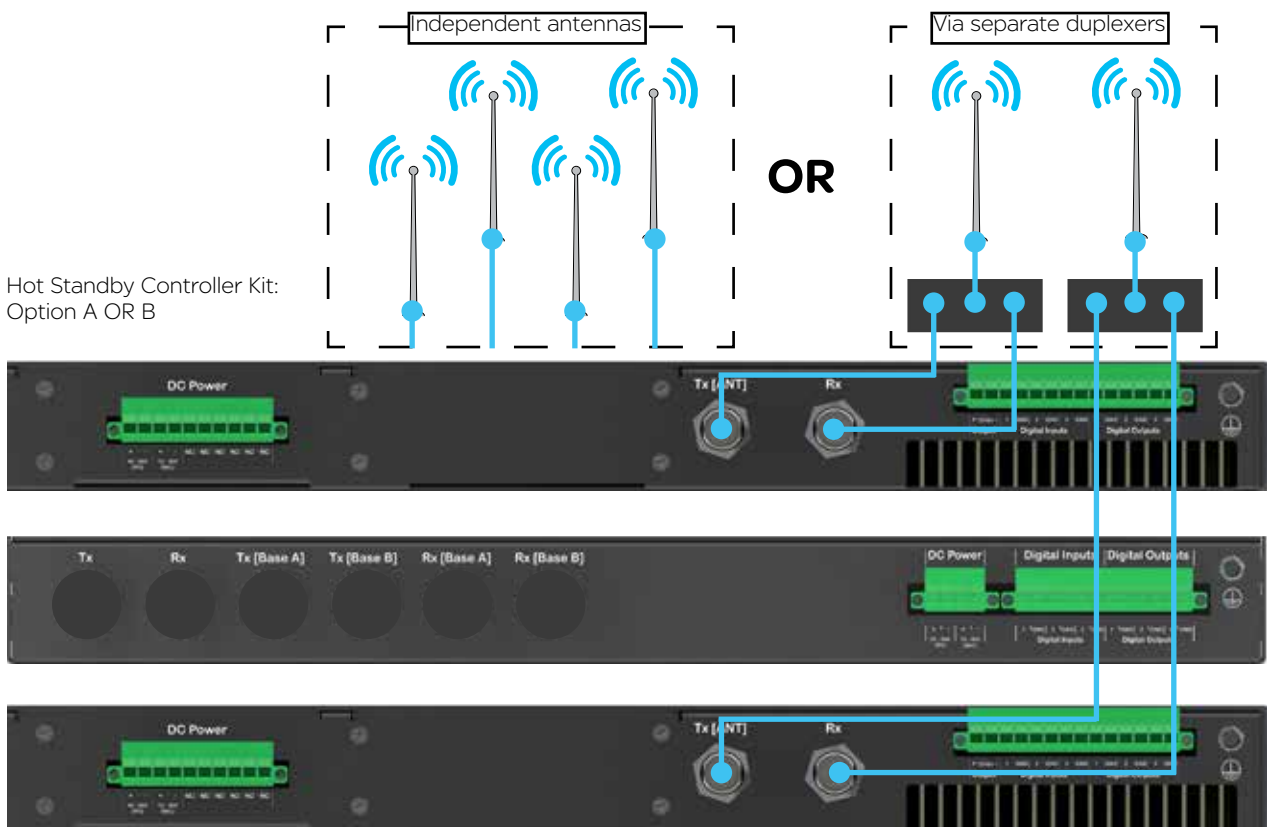

Hot Standby Controller Kit: Option A OR B

Physical Interfaces

Front Panel

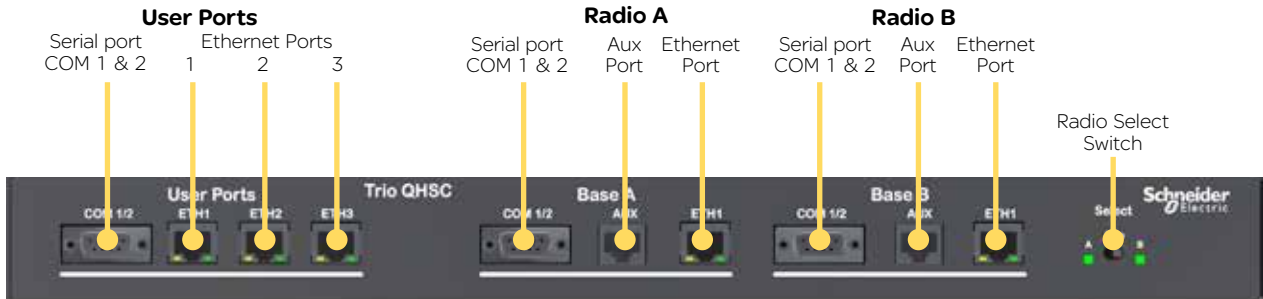

User Ports

Digital switching in the hot standby controller directs user data to and from the user ports on the front panel directly to the user ports on the online radio.

Ethernet Port LED Indicators

Indicated State	ETH port
Ethernet port inactive, no cable connected	
Ethernet port active @ 10Mbps	
Ethernet port active @ 100Mbps	

Select Switch

The 3 position switch (A / Auto / B) on the front panel provides the following functionality:

- Position A: Radio A is forced online
- Position Auto: changeover hardware will select the online radio
- Position B: Radio B is forced online

Adjacent to the Select switch are two LEDs. These LEDs indicate the current online radio.

Indicated State	Select LEDs
Auto Mode	
Local Force	
Remote Force	

Pairing Alarm

Each QB within a Hot standby arrangement, should have HSC Mode enabled by the user. If HSC Mode is disabled in both QBs, the HSC will indicate a pairing alarm by illuminating the A & B LEDs RED.

Rear Panel (Hot Standby Controller Option A)

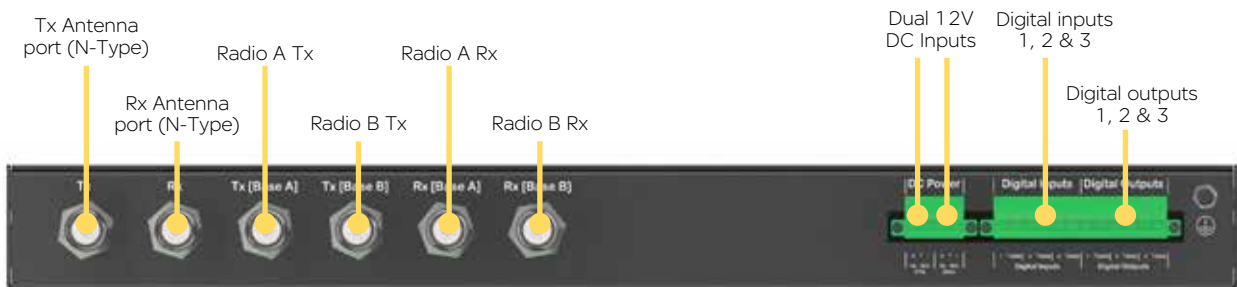

Hot Standby Controller Option B

The QHSC Option B connections are identical to option A however, option B does not include any RF interfaces on the HSC.

LED indicators

Each image below shows where to find the LED indicators of each Q data radio.



Top of QR



Front of QR



Front of QB & QP



Front of QB, QP & QHHSC

Pwr/TX - DC Power & TX LEDs

If all the LEDs are off, no DC power is reaching the radio modem or the internal fuse is open. Successful power-up is indicated by the Pwr/Tx LED showing a continuous GREEN state.

Tx Indicator (Tx) : When the transmitter is active the Pwr/Tx LED is in a RED state.

The QR will take approximately 60 seconds to boot up - during this time, the DC power LED will flash green/off periodically along with various LED activity. Wait until the DC power LED is not longer periodically flashing and is in a solid green state before attempting to communicate with the radio.

Indicated State	Pwr/Tx
No power, or ShutDown	
Power on	
Transmitter On	

Sync/No RX - Synchronisation and No Received Signal LEDs

A flashing or solid green Sync/No RX LED indicates that the modem is receiving decodable transmissions from another source.

A regular/solid flashing red Sync/No RX LED indicates that the modem is receiving un-decodable transmissions from another source. This symptom can be caused by insufficient RX signal, too much interference or an incorrect configuration parameter set within the pair of modems.

Indicated State	Synch/RxSig
No received signal	
Receiver in SYNC state	
RSSI over mute level and no sync	

TxD/RxD (COM 1 and COM 2) - Serial TxD/RxD LEDs

The RxD/TxD LEDs indicate data flow into/out of the serial user port. Data being sent to the port for transmission is indicated by a red flash, and data being received over the air and then forwarded to the serial port is shown as a green flash. As the serial port is full duplex, there may be instances where the TxD and RxD LEDs illuminate simultaneously, this will be indicated by an amber illumination of the port LED.

Indicated State	COM1/2
No Activity	
RxD Data Output	
TxD Data Input	
RxD & TxD Data Active	

ETH 1 & ETH 2 - Ethernet Link and Activity LEDs

The Ethernet port LEDs are found on the physical RJ45 sockets, located on the front panel. Green LED activity typically represents a current physical connection to another Ethernet device has been established. Amber LED activity indicates Ethernet data is being transferred between the local Ethernet port and another Ethernet device.



Indicated State	ETH port
Ethernet port inactive, no cable connected	
Ethernet port active @ 10Mbps	
Ethernet port active @ 100Mbps	

Alarm detection indicator LED (QB & QP only)

The Alarm LED state has two states:

Green: No alarms are currently detected.

Red: An alarm or alarms are currently active. This can be a critical alarm or an enabled user alarm. See alarms section for further details.

Indicated State	Alarm
No active alarm	
Alarm/s detected	

Alarm LED Indications

In some circumstances the radio will indicate an alarm state. This is shown as all LEDs flashing RED for 1 sec and then a pattern of green LEDs for 1 sec. The pattern of green LEDs indicate the type of alarm. Consult the table for more information.

QR Half Duplex Remote				
Alarm Type	COM 1 Rx/D / Tx/D	COM 2 Rx/D / Tx/D	Sync / NoRx	Pwr / Tx
Supply voltage alarm				Green
Retry Factory default		Green		
Configuration alarm		Green		Green
Firmware upgrade alarm		Green	Green	
Reverted to factory default due to internal alarm		Green	Green	Green
IP address not set (DHCP)	Green			
Configuration record not found	Green	Green		
Over temperature alarm (Tx has been disabled)	Green	Green		Green
Over temperature alarm (Tx has been folded back)	Green	Green	Green	
VSWR alarm	Green	Green	Green	Green

QB / QP				
Alarm Type	Pwr / Tx	Sync / NoRx	COM 1 Rx/D / Tx/D	COM 2 Rx/D / Tx/D
Supply voltage alarm	Green			
Pairing Alarm (Hot Standby Mode)	Green	Green		
Retry Factory default				Green
Configuration alarm	Green			Green
Firmware upgrade alarm		Green		Green
Reverted to factory default due to internal alarm	Green	Green		Green
IP address not set			Green	
Configuration record not found			Green	Green
Over temperature alarm (Tx has been disabled)	Green		Green	Green
Over temperature alarm (Tx folded back)		Green	Green	Green
VSWR alarm	Green	Green	Green	Green

HSC Mode Alarm

Each QB within a Hot Standby arrangement should have HSC Mode enabled by the user. When HSC mode is enabled, the QB will attempt to negotiate and pair with an alternate QB. If HSC mode is disabled, a QB will ignore any HSC mode negotiation messages it receives.

QB (within a QH)				
Alarm Type	Pwr / Tx	Sync / NoRx	COM 1 Rx/D / Tx/D	COM 2 Rx/D / Tx/D
Pairing Alarm	Green	Green		
Description of Alarm	When a QB in HSC mode attempts to negotiate with the alternate base, and no response is received, a pairing alarm will be displayed (flashing all red, then, green as shown above)			
Probable Causes	(1) There is a mismatch in the configuration between Base A and Base B. Check that HSC mode, IP address, SUBNET mask, shared IP and VLAN parameters are suitably configured. For further information on configuration of Hot Standby radios refer to Part G of this user manual. (2) There is a problem with the cable connection in the hot standby arrangement. Check cables are properly inserted into their correct locations. Refer to "Step 2 - Interface Connections" in the 'QH Quick Start Guide' section.			

The QHHSC (hot standby controller) indicates an alarm when no QBs are connected (the connection is detected via the Auxiliary interface). While this alarm is active, the QHHSC front panel becomes inactive.

QHHSC		
Alarm Type	Radio A	Radio B
No Base Detected Alarm	Red	Red

QHHSC Change-Over Pending Timer Alarm

After a change-over occurs within a hot standby arrangement, the QHHSC will run a 60 second timer. If a new alarm is detected on the online QB during this 60 seconds, the QHHSC will prevent the change-over and indicate a 'Pending Timer' alarm. Once the timer reaches 0, the change-over will proceed. The pending timer helps prevent a high number of change-overs occurring in a short period of time.

A pending timer alarm is indicated on the QHHSC with a flashing green LED on the corresponding radio LED (Radio A/B).

QHHSC		
Alarm Type	Radio A	Radio B
Pending Timer (To change from Radio A)	Green	
Pending Timer (To change from Radio B)		Green

PTT Timeout Alarm

When the PTT timeout limit is reached (default is 60 Seconds) the following RED LED will begin to flash on its own.

QB / QP				
Alarm Type	Pwr / Tx	Sync / NoRx	COM 1 Rx/D / Tx/D	COM 2 Rx/D / Tx/D
PTT Timeout Alarm	Red			

QR				
Alarm Type	COM 1 Rx/D / Tx/D	COM 2 Rx/D / Tx/D	Sync / NoRx	Pwr / Tx
PTT Timeout Alarm				Red

Operational Alarm

An operational alarm is indicated by all 4 LEDs periodically flashing red (no green flashes). This alarm can indicate the radio has detected an error which may not be recoverable by the user. Depending on why the operational alarm has occurred, the event log can be referred to, which may help diagnose why operation alarm is active.

QR / QB / QP				
Operation Alarm	Red	Red	Red	Red

Connecting Antennas

The RF antenna system should be installed in accordance with the manufacturer’s instructions and local regulatory requirements.

- The RF (Antenna) connector on the QR450 is a TNC type female connector.
- The RF (Antenna) connectors on the QR150 are user-configurable to operate in;
 - Shared Tx/Rx mode on the TNC type female connector.
 - Separate Tx on the TNC type female connector, and Rx on the SMA type female connector.
- The RF (Antenna) connectors on the QB and the QP are N-Type female connectors.

Good quality, low loss, feeder cable, should be considered according to the length of the cable run. Also, use a short, flexible patch cable between the radio and lightning arrestor or flange mount of the radio cabinet/enclosure. Ensure that all external connections are waterproofed.

Communication Ports

Ethernet Ports (ETH)

The ETH ports are 10/100 Base-T compliant, using RJ-45 sockets. These sockets support both TIA/EIA-568-A & B wiring as they have Auto MDI/MDIX Auto Sensing. This means you can use both straight-through and cross-over type CAT-5 or better patch cables. All RJ45 connectors should utilise mating plugs that include an integral locking tab.

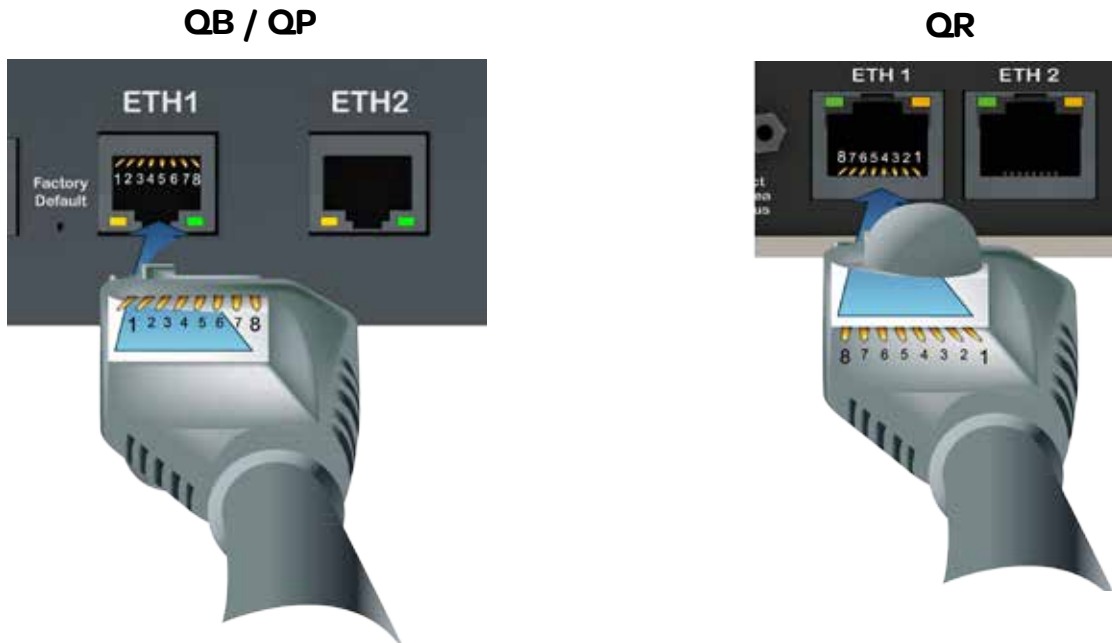

If termination of a cable is required, then the following wiring arrangement should be followed (Compliant with TIA/EIA-568-A).

Maximum differential voltage : 5v, 50mA max through each differential pair.

If 100-BaseT connection speed is required, CAT-6 Shielded cable should be used for installation to comply with ETSI EMC directives.

Pin	Pair	Wire	Color
1	3	tip	 white/green
2	3	ring	 green
3	2	tip	 white/orange
4	1	ring	 blue
5	1	tip	 white/blue
6	2	ring	 orange
7	4	tip	 white/brown
8	4	ring	 brown

Serial Ports - COM 1/2

The Q data radios feature a 9 pin miniature D-Shell (DE-9) Female connector that supports two individual serial port connections. Each serial port is associated with an embedded serial terminal server that provides the serial to TCP/IP or UDP/IP connectivity.

- COM 1 uses pins 2, 3, 7 & 8 with pin 5 as the common ground.
- COM 2 uses pins 4 & 6 with pin 5 as the common ground.
- An RSSI output is available on pin 9 which is useful for antenna alignment.

Pin out specs:

- (1) Pin 2, 6 & 8 are outputs rated at +/- 6v, 65mA max.
- (2) Pin 3, 4 & 7 are inputs rated at +/- 15v, 5mA max.
- (3) Pin 9 is an analog voltage output to indicate the radio's live RSSI measurement.
- (4) Connecting wires should be #22 AWG (0.33mm²) or larger.

QB / QP



QR450



QR150



Pin	RS-232 Mode		RS-485 Mode	
	Name	Input/Output	Name	Input/Output
1	COM 1 DCD	Output	Not Used	-
2	COM 1 RxD	Output	B/Z (Inverting)	Input/Output
3	COM 1 TxD	Input	A/Y (Non-Inverting)	Input/Output
4	COM 2 TxD	Input	Not Used	-
5	GND	-	Not Used	-
6	COM 2 RxD	Output	Not Used	-
7	COM 1 RTS	Input	Not Used	-
8	COM 1 CTS	Output	Not Used	-
9	RSSI	Output	RSSI	Output

Activating Transmitter

Data sent to either of the radio's communication ports (Ethernet or Serial Port) will cause the radio to key up its transmitter and send the data over the air. However, to test the transmitter with external test equipment (Tx power, VSWR or Frequency), or to test another radio's receiver, the Q data radio provides a means to manually control the activation of the transmitter.

To access the transmit test tool, access the radio's web user interface and browse to: Maintenance -> Transmit Test. This will display the transmit test tool page.

The transmitter can now be controlled via this page. To key up the transmitter, press the 'Turn ON' button. By default this will enable a Modulated Carrier for 60 seconds. During this time, the Tx LED should illuminate solid RED to indicate the transmitter is active.

If the power or frequency is adjusted, and it is desired to retain this value, the Save and apply button should be pressed to activate the changes in the radio.

Transmit Test

Transmitter State	<input type="button" value="Turn on"/>
Transmit Carrier	<input type="text" value="Modulated"/>
Transmit Idle Time (s)	<input type="text" value="60"/>
Power Level (dBm)	<input type="text" value="30"/> <input type="button" value="+"/> <input type="button" value="-"/>
Frequency Trim (Hz)	<input type="text" value="0"/> <input type="button" value="+"/> <input type="button" value="-"/>
	<input type="button" value="Save and apply"/>

Factory Default

The factory default IP address of the Q data radios is **192.168.2.15**. If you want to perform configuration changes on the Q data radio and are not aware of the configured IP address, you may need to activate a factory reset. Alternatively, COM 1 can provide access to the radio's configuration via Text User Interface (as long as this port remains at the default configuration). default interface settings are: 19200, N, 8, 1, No Handshaking.

A factory reset will cause all previous configuration settings to be erased and returned to the factory default values. A factory default can be initiated by applying DC power to the radio (wait up to 3 minutes for the unit to fully boot up, indicated by a solid GREEN Power LED), depress the factory default switch using a paper clip or similar object and keep the switch depressed for 6 seconds or until all four LEDs illuminate solid GREEN and begin flashing, indicating the radio will return to the factory default settings. Wait for up to 4 minutes for the factory default reset process to complete.

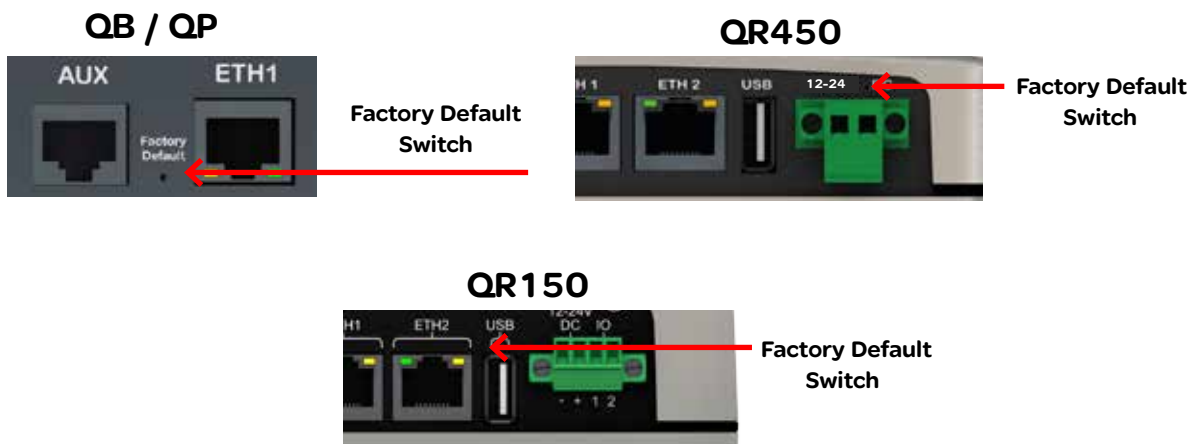

Digital I/O

The following Trio Q radios provide three dedicated Digital inputs as well as three digital outputs which can be read/written to via TView+ Diagnostics or SNMP.

- QB Full Duplex Radio
- QH Hot Standby Full Duplex Radio
- QP Hot Standby Half Duplex Radio

QH / QB / QP

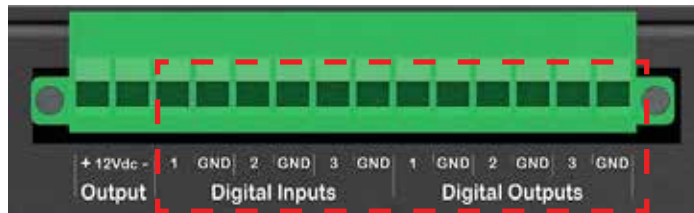

The QR150 provides two pins, dedicated for digital I/O. This I/O is user configurable, allowing each pin to be configured as either a digital Input or a digital output.

QR150

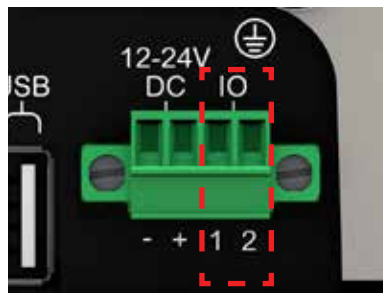

SNMP object descriptions for digital I/O can be found within the advanced section of this manual.

Inputs

The digital inputs for the QH/QB/QP & the QR150 have the same operational characteristics, the following input methods can be used across either of these hardware variants.

Some form of switching contact (i.e: switch, relay) is normally used to change the state of the input. Both an isolated and non-isolated input configuration is possible.

Typical input drivers include: dry contact (relay), electronic control or driven control. Each input can support either type of driver.

Reading the status of a user input while the circuit is CLOSED will report the input as being ON.

Reading the status of a user input while the circuit is OPEN (or not connected) will report the input as being OFF.

Typical Input Drivers

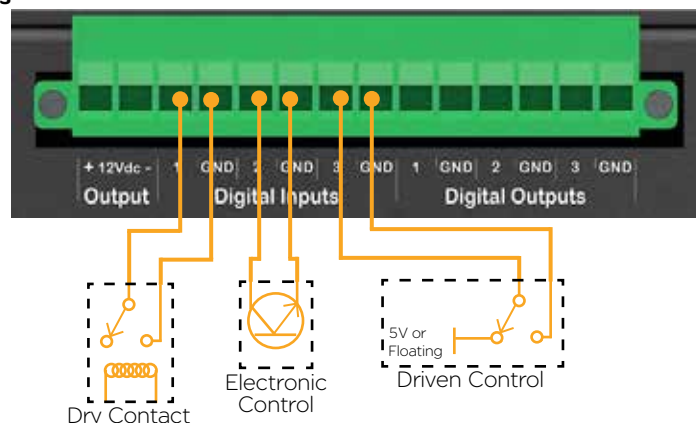

Outputs

The digital outputs for the QH/QB/QP & the QR1 50 have the same operational characteristics, the following output methods can be used across either of these hardware variants. Each output is an open collector.

Power Specifications

Maximum Voltage allowed across each output is 30 Vdc.

Maximum current allowed through each output is 1 A. External resistors or a current limited supply should be used to keep the current below this value.

When the OUTPUT is OFF, The circuit will be OPEN. When the OUTPUT is ON, The circuit will be CLOSED.

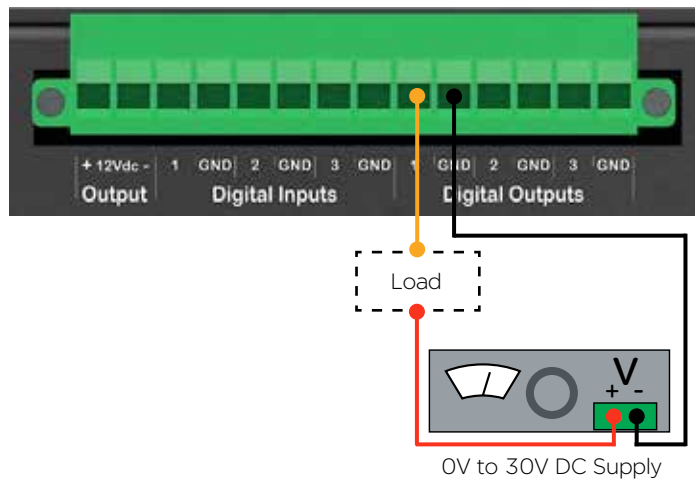

Connecting to Web User Interface (WUI)

Q data radios provide an embedded web server which provides access to the Web User Interface (WUI). The WUI can be used to perform configuration changes on the radio. To change a configuration parameter in a Q data radio, connect a PC to one of the Ethernet ports (ETH 1 or ETH 2) and direct a browser to the IP address of the Q data radio. It is strongly recommended that you follow these guidelines for successful connection to the radio:

(1) Ensure that the Q data radio is powered up and has fully booted. This is indicated by a solid GREEN power LED. It takes approximately 2 minutes from applying DC power for the Q data radio. Once the radio is fully booted, it may be indicating a user alarm. For example, if the radio's antenna port is incorrectly terminated, the radio will indicate a high VSWR alarm. Regardless of this user alarm, the radio can still be browsed to.

(2) Disconnect the PC from any other Internet/LAN networks, as this may create a conflict in IP addresses or the Q data radio IP might not fall within the subnet mask specified by the network.

(3) Connect the PC's Ethernet Port to one of the Ethernet Ports (ETH 1 or ETH 2) using an RJ-45 patch cable. Cross over cables will also work (Ethernet ports support MDI/MDIX). An active connection is indicated on the radio by solid green and amber illumination on the LEDs which are fixed to the physical Ethernet port you are connected to.

(4) Ensure that the PC LAN Port is configured for a suitable IP address. If you are using Windows 7, this can be done by configuring the LAN settings via the Control Panel. Navigate to the Windows "Start" button and open Control Panel -> Network and Sharing Center -> Change adapter setting -> Double click on the LAN port you are using -> Properties -> Double click 'TCP/IPv4'. You should see the window shown.

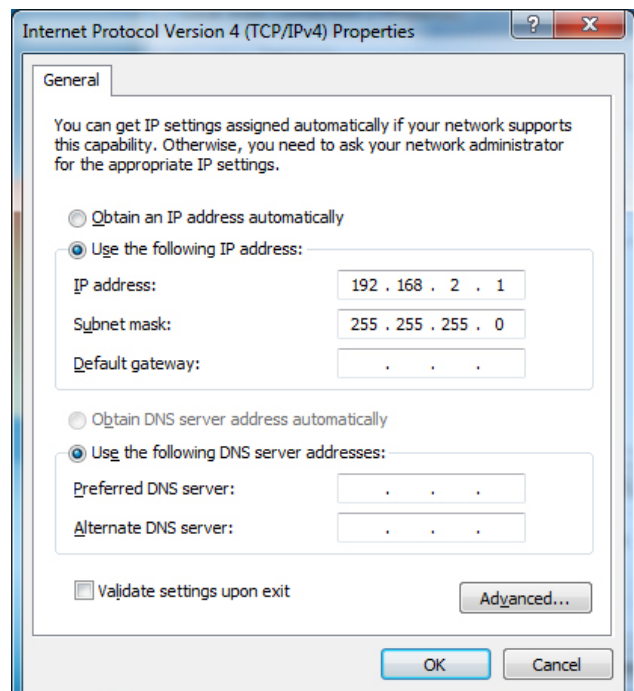

Ensure that "Obtain IP Address Automatically" is NOT selected. It is recommended that you manually specify a compatible IP Address. In this example, a factory default radio is being configured. The IP address of that radio is 192.168.2.15 and a compatible IP address for the PC would be 192.168.2.1. Click OK to accept the changes.

Check with your Network Administrator before allocating IP addresses as each LAN/WAN network is different.

(5) Now open the web browser and insert the IP address of the Q data radio into the URL. In this case, we type "192.168.2.15", the browser should now display the home page of the radio. (Shown below).

You may need to disable a web proxy (if in use) or disable or modify the local firewall to help ensure the security.



Resolving Ethernet Connection Issues

Here are some basic tips to help you along the way with Ethernet configuration issues. The Windows operating system (and others) comes complete with many useful tools. First, you need to open a command window. This can be done by clicking on “Start” then “Run” and entering “CMD” and clicking OK.

Obtaining IP information about your PC

If you need to find out more information about your computer’s Ethernet IP configuration, network gateways and DNS servers, you can use a tool called “IPConfig”. Simply type “IPconfig /all” into the command window.

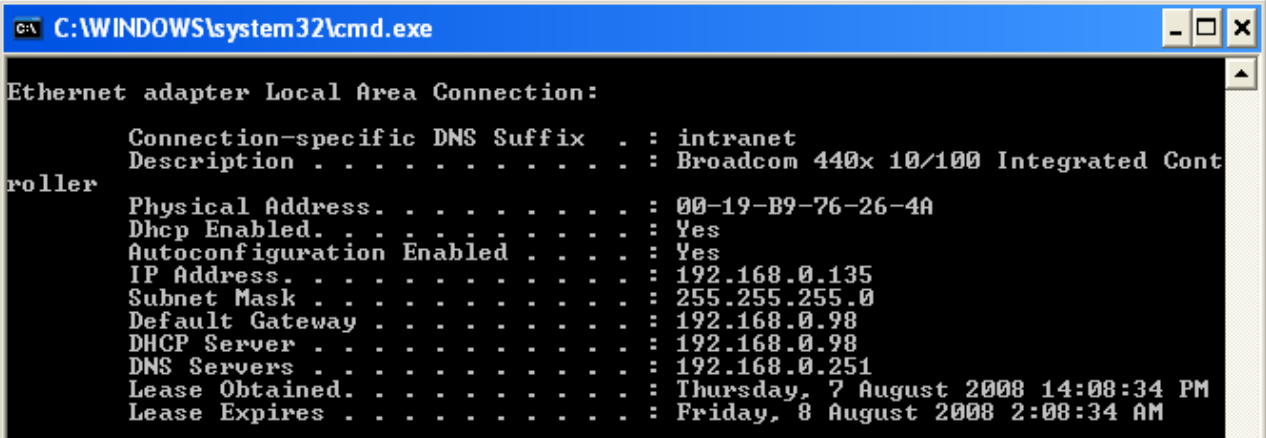

```

C:\WINDOWS\system32\cmd.exe

Ethernet adapter Local Area Connection:

    Connection-specific DNS Suffix  . : intranet
    Description . . . . .           : Broadcom 440x 10/100 Integrated Cont
roller
    Physical Address. . . . .       : 00-19-B9-76-26-4A
    Dhcp Enabled. . . . .           : Yes
    Autoconfiguration Enabled . . . : Yes
    IP Address. . . . .             : 192.168.0.135
    Subnet Mask . . . . .           : 255.255.255.0
    Default Gateway . . . . .       : 192.168.0.98
    DHCP Server . . . . .           : 192.168.0.98
    DNS Servers . . . . .           : 192.168.0.251
    Lease Obtained. . . . .         : Thursday, 7 August 2008 14:08:34 PM
    Lease Expires . . . . .         : Friday, 8 August 2008 2:08:34 AM
  
```

Checking IP connectivity

A reliable way to check IP connectivity to a device is using the “Ping” utility. Type “ping xxx” where xxx is the complete IP address of the destination device you want to check. Ping will either respond with latency results (as shown) or say “timed out” if no connection was possible.

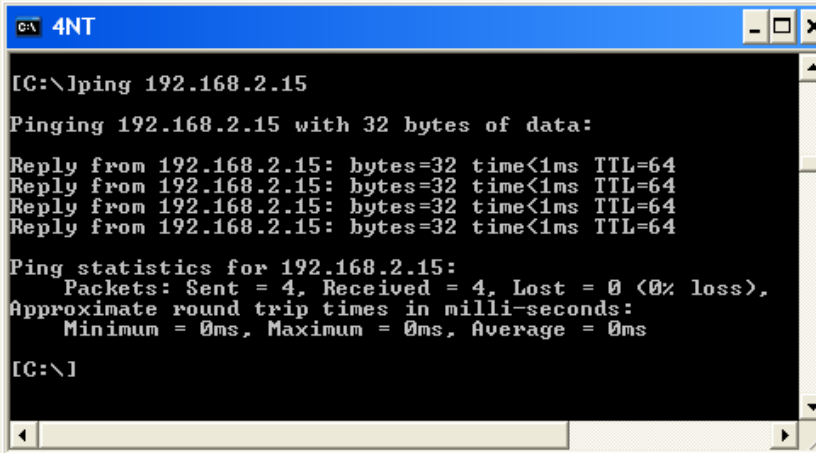

```

C:\ 4NT

[C:\>ping 192.168.2.15

Pinging 192.168.2.15 with 32 bytes of data:

Reply from 192.168.2.15: bytes=32 time<1ms TTL=64
Reply from 192.168.2.15: bytes=32 time<1ms TTL=64
Reply from 192.168.2.15: bytes=32 time<1ms TTL=64
Reply from 192.168.2.15: bytes=32 time<1ms TTL=64

Ping statistics for 192.168.2.15:
    Packets: Sent = 4, Received = 4, Lost = 0 (0% loss),
    Approximate round trip times in milli-seconds:
        Minimum = 0ms, Maximum = 0ms, Average = 0ms

[C:\>]
  
```

Repeated connections to multiple devices with same IP address

A common issue experienced when attempting to configure multiple radios with the same IP address (such as factory default radios). The issue is due to invalid MAC table entries. If you change the Ethernet connection between two devices with the same IP address quickly, you may need to reset the MAC look up table in the PC. You can do this by typing “arp -d” in the command window.

Part G– Quick Start Guide

Step-by-Step Point to Point Setup

Introduction

This document describes the 10 key steps required for:

- Connecting and configuring a pair of Q data radios.
- Performing basic diagnostics and health checks
- Connecting user equipment such as Host Software and/or RTUs

Typical Bench setup

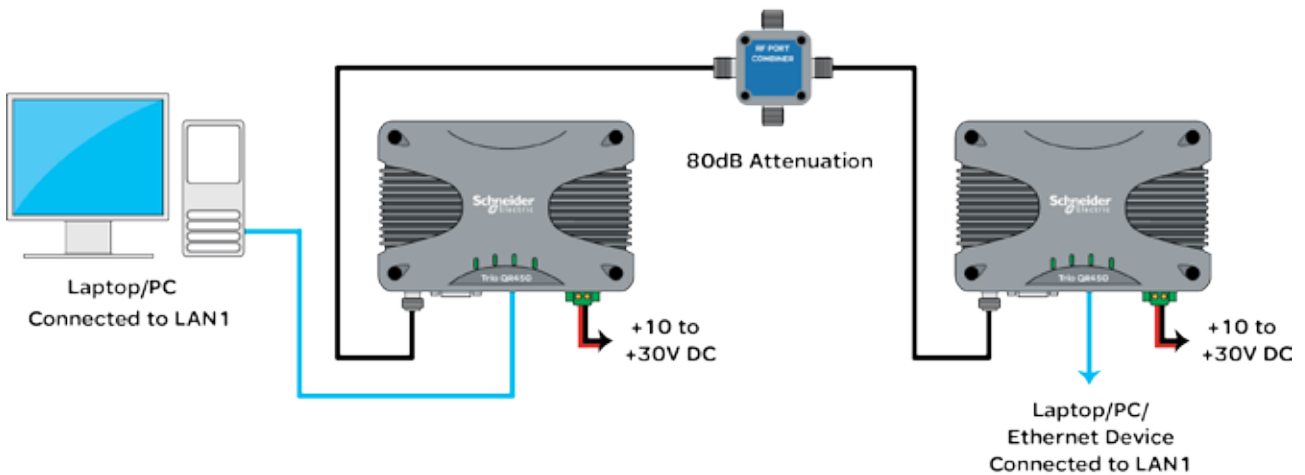

Step 1 - RF and DC power connection

RF Connection

Bench testing is typically performed over short distances, so RF signals need to be significantly attenuated. Using dummy loads or whip antennas is not recommend.

A suitable method for attenuation of RF signals is to use a 4 Port RF Attenuator (Part Number TBUM4PORTATTEN). An attenuator accurately reduces RF signal level, simulating a real world, long distance RF link. Other types of RF attenuators can be used providing the total attenuation is between 80dB to 100dB. Check the attenuator power ratings against the configured Tx power of the radio.

If the TX power of each radio is set to 20dBm (100mW) then, low power, low cost attenuators can be used.

DC Power Connection

Ensure that each radio is wired using the correct polarity and that power supply is regulated and has adequate current delivering capacity. See the Quick reference guide section of this manual to confirm the power supply requirements you require for the product you are using.

Step 2 - Power Up Radios

Apply DC power to the radios. The radio will begin a boot up process. This process can take up to 2 minutes (during this time frame, the 'Pwr' LED will periodically flash GREEN, indicating that the boot up process is still in progress).

Once the boot up process has completed, the 'Pwr' LED should be solid GREEN. If there is no LED indication, re-check the DC polarity and ensure that the DC voltage is between operating voltages.

If these checks are correct they you may need to inspect the internal fuse. Consult the maintenance section of this manual for further information on fuse replacement.

Step 3 - Setup for Radio Configuration

IP Address and Factory Default

The factory default IP address of the Q data radios is **192.168.2.15**. If you want to perform configuration changes on the Q data radio and are not aware of the configured IP address, you may need to activate a factory reset. Alternatively, COM 1 can provide access to the radio's configuration via Text User Interface (as long as this port remains at the default configuration). default interface settings are: 19200, N, 8, 1, No Handshaking.

A factory reset will cause all previous configuration settings to be erased and returned to the factory default values. A factory default can be initiated by applying DC power to the radio (wait up to 3 minutes for the unit to fully boot up, indicated by a solid GREEN Power LED), depress the factory default switch using a paper clip or similar object and keep the switch depressed for 6 seconds or until all four LEDs illuminate solid GREEN and begin flashing, indicating the radio will return to the factory default settings. Wait for up to 4 minutes for the factory default reset process to complete.

Connection to Embedded Web User Interface (WUI) - HTTP

Connect the PC Ethernet Port to one of the Ethernet Ports (ETH1 or ETH2). To verify you can communicate with the QR you should first ping the radio.

Open up a command window on the PC by going to the "Start" -> Run and typing "CMD" then OK. Then type "ping 192.168.2.15" which is the default address of the radio. The radio should respond to the ping as shown below. If this is not the case, refer to the 'Resolving Ethernet Connection Issues' section in Part F of this manual.

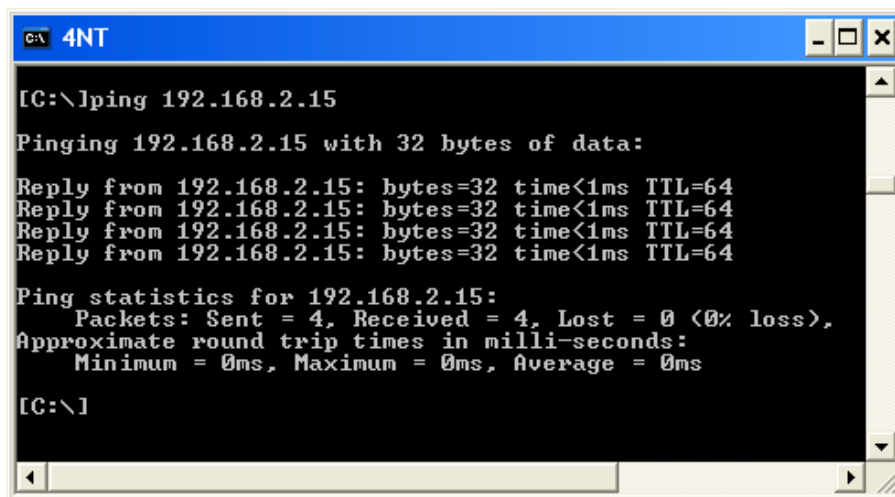

```

C:\>ping 192.168.2.15

Pinging 192.168.2.15 with 32 bytes of data:

Reply from 192.168.2.15: bytes=32 time<1ms TTL=64
Reply from 192.168.2.15: bytes=32 time<1ms TTL=64
Reply from 192.168.2.15: bytes=32 time<1ms TTL=64
Reply from 192.168.2.15: bytes=32 time<1ms TTL=64

Ping statistics for 192.168.2.15:
    Packets: Sent = 4, Received = 4, Lost = 0 (0% loss),
    Approximate round trip times in milli-seconds:
        Minimum = 0ms, Maximum = 0ms, Average = 0ms

C:\>

```

Q Data Radios can also be configured via a Text User Interface (TUI). Console protocols such as Telnet, SSH or a serial connection may be used. For further details on making configuration changes via the TUI, refer to the advanced configuration section of this manual.

Step 4 - Start Web Browser on your PC

Start a web browser and insert the IP address of the radio into the URL. In this case, type "192.168.2.15" and the configuration page is now displayed in the browser.



Browse to the "Wizards" section of the WUI by clicking: -> Setup -> Wizards.

Step 5 - Activate Entry Point - PTP Wizard

Select Point to Point with Half Duplex Entry Point.

Select 'Entry Point radio' and click on the "Start The Wizard" button.

The Wizard now prompts the user to configure the minimum parameters to achieve point to point operation. For each configuration item, help text is provided on the HTML programmer interface. If you are manually specifying IP addresses, ensure that you record them for future reference. You will need to know the IP address of each radio in future steps.

After configuration of all items are complete, activate the configuration by clicking on the "Activate Configuration" button in the top right corner.

Shared IP Address (Optional Configuration - For Hot Standby units only)

Radio A and Radio B (within the QP) can be configured to 'share' an IP address. This is a separate IP address from each radio's unique IP address. The shared IP address can be used to access the current 'online' radio.

The shared IP address should be configured in each individual internal radio as the same IP address.

To configure the shared IP address, go to: Setup -> Basestation -> General and enable Shared IP Mode.

Shared IP Mode Enabled Disabled

Shared IP

Step 6 - Activate Remote - PTP Wizard

Repeat steps (3) to (5) for the Remote radio. When in Step 5, select the 'Remote radio' button and click on the 'Start The Wizard' button.

Step 7 - Verify Modem Operation

The radio configuration & RF link can now be verified for correct operation. First, check that the remote radio can correctly decode a transmitted signal. This is done by energising the transmitter (modulated carrier) of the entry point radio. Refer to the instructions about this in the quick reference guide section of this manual.

With the transmitter energised, inspect the LED status on each radio. The entry point radio should have a solid RED 'Pwr/Tx' LED. The remote radio should a solid GREEN 'Sync/RxSig' LED. If this LED is not SOLID green it may indicate incorrect configuration or inadequate signal strength and the setup should be checked. Repeat this test with the Remote radio transmitting.

Step 8 - Packet Transmission Test

This tool provides a useful way to test a radio communications link by transmitting data packets between two units in a loop-backed mode.

You can find this tool in the "Diagnostics" tab, then click on the "Packet Transmission Test" sub-menu.

Enter the "Destination IP Address" field with the IP address of the of the target radio that you want to ping. Ensure that the "Number of Packets" is set to 1000. Now click on the "Start Packet Test" button. The radio will indicate the packet test has started and is currently running and both units will have flashing Tx LEDs indicating data is being transmitted.

When the test is complete, a message stating "Packet transmission test completed" will be shown and the test results summarised in the "Test Results" section.

The test results show TX & RX Packets, Lost Packets and the Packet Error Rate.

The screenshot shows the 'Packet Transmission Test' window. At the top right is a 'Start Test (Continuously Repeat)' button. Below it is a note: 'This test will send continuous packets to an IP address. If the system is live, and destination device is across a radio link, collisions are likely which may affect the resulting error rate.' The configuration section includes: Destination IP Address (192.168.2.20), Packet Length (B) (100), Number of Packets (10), Timeout (s) (5), Time Between Packets (ms) (100), and Time Between Refresh (s) (1). The Results section shows: Transmit Packet Count (0), Receive Packet Count (0), Lost Packet Count (0), Percentage Error (0), and Normalised Packet Error Rate (0).

Step 9- Embedded Diagnostics Testing

8.1 Review Diagnostics

Connect the web browser to the Entry Point radio using the IP address recorded in Step 5. Once loaded, click on the Diagnostics tab, then select the summary sub-menu. This will display the Diagnostics summary page. Review the diagnostics parameters checking for abnormal items such as high VSWR (high TX reverse power) and lower than expected radio RSSI (Received Signal Strength).

Follow this step again for the Remote radio.

Summary

Unit

Date	Mon Nov 24 18:14:28 1975
Up Time (sec)	2585.37
CPU Load (%)	7
Supply Voltage (V)	13.7
Radio Temperature (C)	40.3
Radio Temperature (F)	104.54

LAN

ETH 1 Rx Packets	317
ETH 1 Rx Bytes	38864
ETH 1 Tx Packets	101
ETH 1 Tx Bytes	27379
ETH 2 Rx Packets	0
ETH 2 Rx Bytes	0
ETH 2 Tx Packets	0
ETH 2 Tx Bytes	0

Radio

Radio Rx Packets	1
Radio Rx Bytes	21
Radio Tx Packets	195
Radio Tx Bytes	18794
Radio Forward Power (dBm)	30.0
Radio Reverse Power (dBm)	28.6
Radio VSWR	> 10.0:1
Radio RSSI (dBm)	-120.1
Radio Rx Frequency Offset (Hz)	0.3

Step 10 - Commissioning Record

After a packet transmission test has been performed, a Commissioning Record can be prepared. This facility is activated by clicking on the "Commissioning Record" button.

It is recommended that the radio is configured to use the current date (either time configured manually or obtained from an NTP server) otherwise the date / time shown will not be correct.

The user can enter an appropriate Unit Name and Location for reference purposes. Additionally, a comment may be added noting the type of antenna in use. Once this information has been added, the web page can be printed (using the print facility in the web browser). It may be useful to print the commissioning record to PDF for future reference.

This now completes the requirements for setting up a half duplex, Point to Point Q Data Radio Link. The radios are now ready for application testing. The application can be connected to either ETH1 or ETH2 or both.

QH Hot Standby Quick Start Guide

Introduction

This document describes the seven key steps required for connecting and configuring a single QH arrangement.

Step 1 - RF and DC power connection

Connect the DC power and Antenna ports following the connection diagrams shown in the QH Quick Reference Guide section.

If antennas are not available, terminate the radios antenna ports with a suitable load or attenuator.

Do not apply DC power to the hot standby arrangement at this stage.

Step 2 - Interface Connections

Connect the interface cables following the diagram below (leaving the QB interconnecting cable [ETH3-ETH3] disconnected).

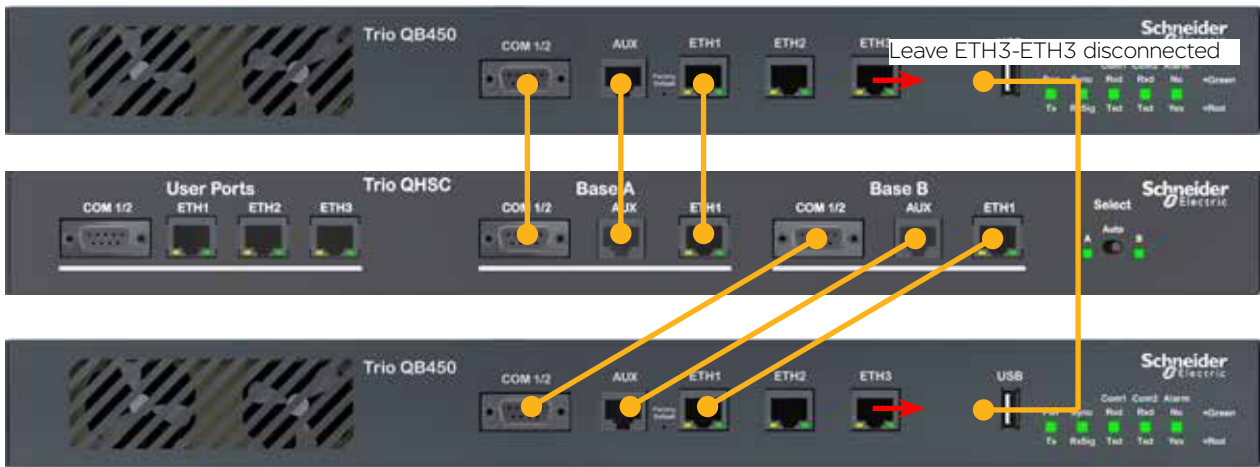

Step 3 - Apply DC Power

Ensure that the radio select switch on the hot standby controller is switched to Radio A.

Apply DC power to the hot standby arrangement, allowing up to two minutes for the radios to power up.

Once the hot standby arrangement is powered up (indicated by a solid green LED state on the pwr LEDs), ensure that the HSC radio select LED for Radio A is illuminated amber. This indicates that Radio A is forced online.

Step 4 - Start Web Browser on your PC

Ensure that each QB radio is in factory default state. This is done by depressing the hidden factory default button on the front panel of each QB for 5 seconds. Allow up to three minutes for the factory default process to complete.

Connect your PC Ethernet port to the ETH 2 interface of Base A. Verify that your PC can communicate with Base A by performing a ping test. The default IP address of a Q data radio is 192.168.2.15.

Start a web browser and insert the IP address of the radio into the URL. In this case, type "192.168.2.15" and the configuration page should now be displayed in the browser.

Further details on factory default and WEB browser connection can be found in the QB Quick Start Guide.

Step 5 - Radio Configuration

There are three main QB configuration parameters to review for hot standby operation:

- **HSC Mode:** Configure the QB to operate within a hot standby arrangement by enabling HSC mode. To access HSC mode, go to: Setup -> Basestation -> General and enable the HSC Mode. Once HSC Mode is enabled, a range of hot standby configuration parameters becomes available.

General

HSC Mode

- **Unique IP Address:** Each QB radio within a hot standby arrangement requires its own unique IP address. To configure the IP address, go to: Setup -> Network -> Ethernet -> IP Address . For this example, the following unique IP address allocations have been given:

- **Base A IP:** 192.168.2.21
- **Base B IP:** 192.168.2.22

- **Shared IP Address:** The two QB radios within a hot standby arrangement can be configure to 'share' an IP address. This is an IP address separate from the radio's unique IP address. The 'online' base within the hot standby arrangement assumes ownership of the shared IP address. The shared IP address has to be configured in Base A & B.

To configure the shared IP address, enable HSC mode, then go to: Setup -> Basestation -> General and enable Shared IP Mode. For this example, the following shared IP address has been allocated:

- **Base A & B Shared IP:** 192.168.2.20

General

HSC Mode

Shared IP Mode Enabled Disabled

Shared IP

When these parameters have been configured, activate the configuration.

Once the configuration is activated Base A will attempt to negotiate and pair with an alternate QB. As Base B is still in a factory default state, HSC mode negotiation messages will be ignored (until HSC mode is enabled). This will cause Base A to indicate a pairing alarm, which can be ignored until Base B has been configured.

QB (within a QH)				
Alarm Type	Pwr / Tx	Sync / NoRx	COM 1 Rx/D / Tx/D	COM 2 Rx/D / Tx/D
Pairing Alarm	Green	Green		

[For further details on alarms, refer to Part F - Quick Reference Guide]

When Base A has been successfully configured, perform the following steps:

- Force Base B online using the radio select switch on the QHHSC
- Begin from Step 4 and configure Base B

Step 6 - Base Interconnection

When Base A and Base B have both been successfully configured, interconnect the ETH 3 interfaces of both Bases. The cable is shown in the diagram below in RED. Once this cable is in place, each base should be able to successfully negotiate with one another and the pairing alarms should stop.

When the cable has been connected, set the radio select switch on the QHSC to the Auto position.

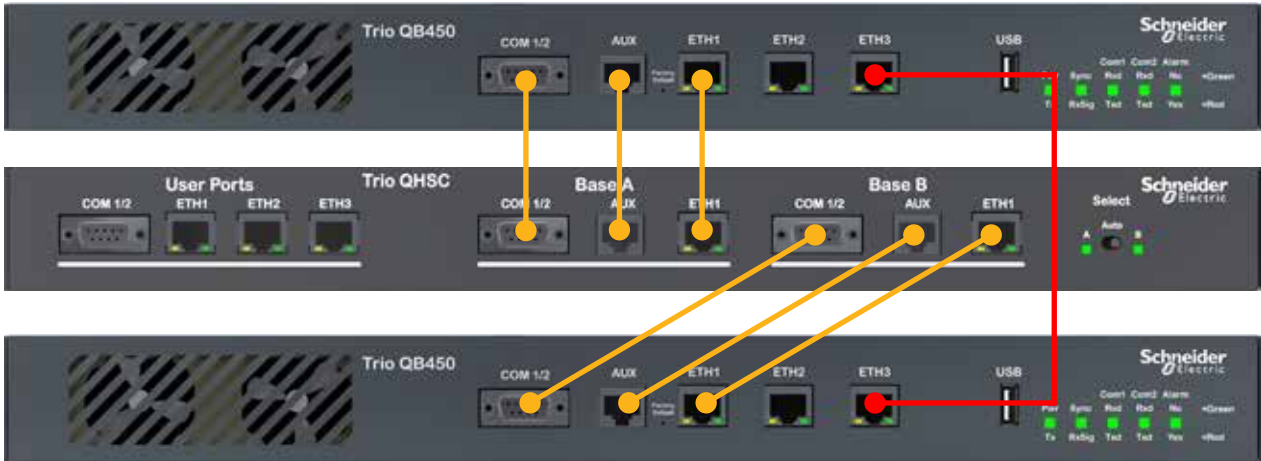

Step 7 - Change-over triggers

When the alarm output becomes active on the online QB, a change-over can occur (as long as the alternate QB does not also have an active alarm output). The alarm output can become active when an alarm is detected. The alarms are user-configurable and can be subscribed to the alarm output.

By default, no alarms are subscribed to the alarm output. It is recommended to review the alarms setup in each base, to ensure that suitable alarms have been subscribed to the alarm output for the given system requirements. If the system requirements are unknown, all of the alarms can be subscribed to the alarm output, then disabled in the future, if no longer required.

Refer to the advanced section of this manual for further information on configuring radio alarms.

Step-by-Step eDiags Setup

Ethernet diagnostics (also known as eDiags) is a feature of the TView+ diagnostics software that encapsulates the TView+ diagnostics protocol in an Ethernet UDP/IP packet. Together with the eDiags server embedded into each Q data radio, the user can monitor a Q data radio network using the TView+ diagnostics software over an Ethernet LAN/WAN. A typical use diagram is shown below.

For more information on the features, benefits and technical details of the TView+ diagnostics software, refer to the TView+ diagnostics user manual.

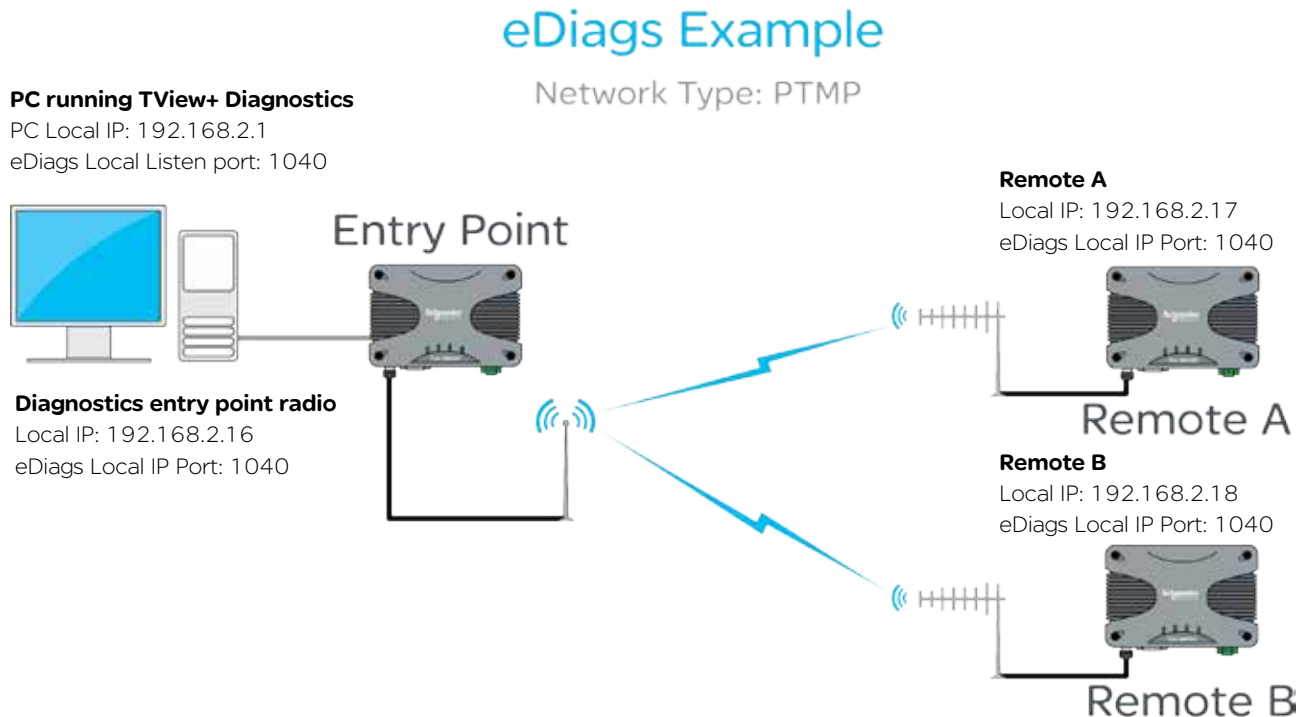

The following instructions will explain how to poll Q data radios using eDiags over a wireless network.

(1) Enable eDiags within each radio that is required to be polled. Configure the following parameter in each radio:

- Local Port number - This will be the port number the eDiags session (within the PC) will address all eDiags data to (example uses: 1040)

(2) Ensure that TView+ Diagnostics software has been installed on the PC

(3) Open the TView+ Diagnostics software on the PC and configure the following items (for detailed instructions on the TView+ Diagnostics software, refer to the TView+ Diagnostics user manual):

- Create a list (database) of Q data radios that are required to be polled for diagnostics. Each data base entry should have the communications port set to eDiags (Ethernet) and configured to use the IP address and eDiags port number of the corresponding radio. Each serial number entered needs to be correct. Other information can also be specified.
- Define the IP address and local listening port number for the eDiags session (controller address and port number). This can be configured in Settings -> eDiags Port settings. The IP address and port number configured, needs to match the controller IP address and controller port number specified within the eDiags settings within each of the radios (they should all have common settings).

This now completes the requirements for configuring eDiags. The operation of eDiags for a typical poll/response diagnostics transaction is as follows:

(1) The TView+ Diagnostics software constructs a UDP/IP data gram which targets the embedded eDiags server of each radio configured within the database.

(2) The UDP datagram is placed onto the LAN/WAN which routes the datagram onto the radio network.

(3) The entry point radio will respond to any poll addressed to it's own IP address and eDiags port, or, will transmit the poll over the air to the targeted radio.

(4) The targeted radio will then respond to the poll, by transmitting a response, which will be sent back to the controller address (the Diagnostics PC).

System Topology Configuration

Transparent Bridge Mode

Introduction

The following Diagrams are designed to provide configuration information on typical topologies. The channel bandwidth and Tx/Rx frequencies are not shown within the diagrams, as they depend on the users license.

The following diagrams show '/24' after an IP address. This short hand addressing indicates the device's subnet mask. '/24' equals a subnet mask of 255.255.255.0

Point to Point - Full Duplex

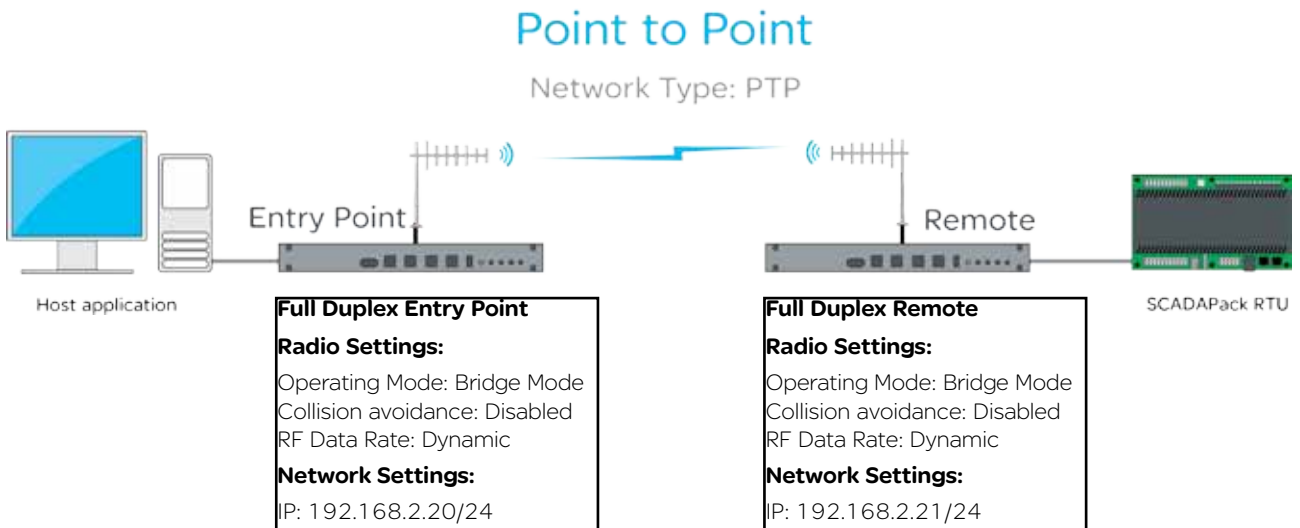

Point to Point - Half Duplex

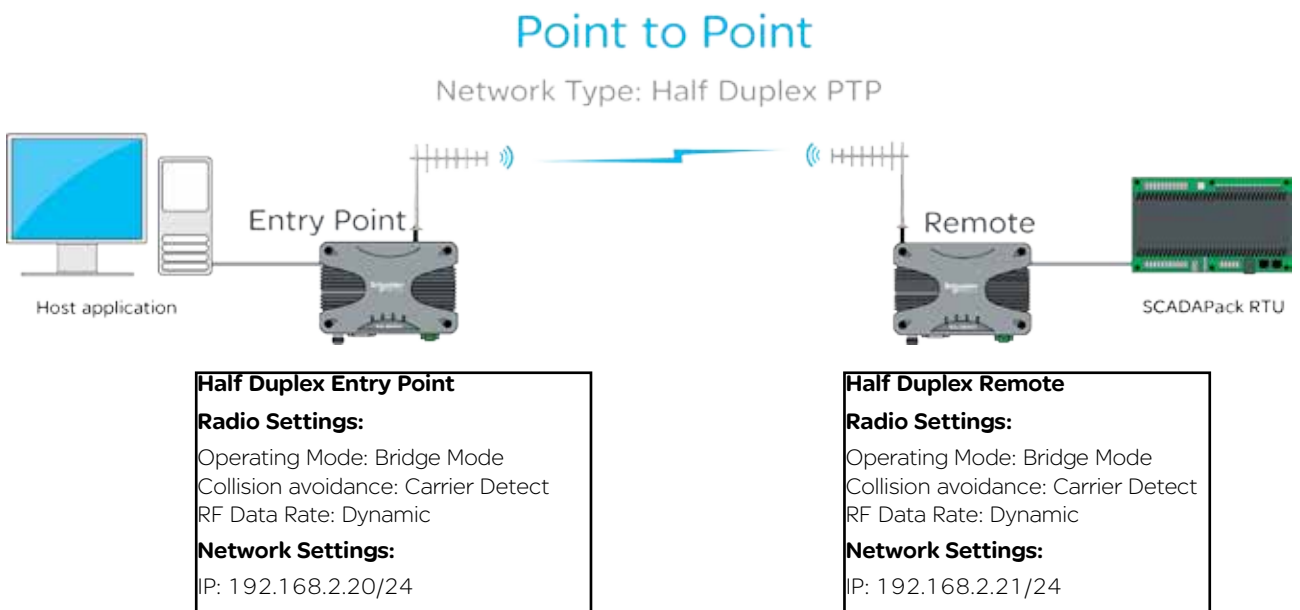

Point to Multipoint - Full Duplex Entry Point

Point to Multipoint

Network Type: PTMP

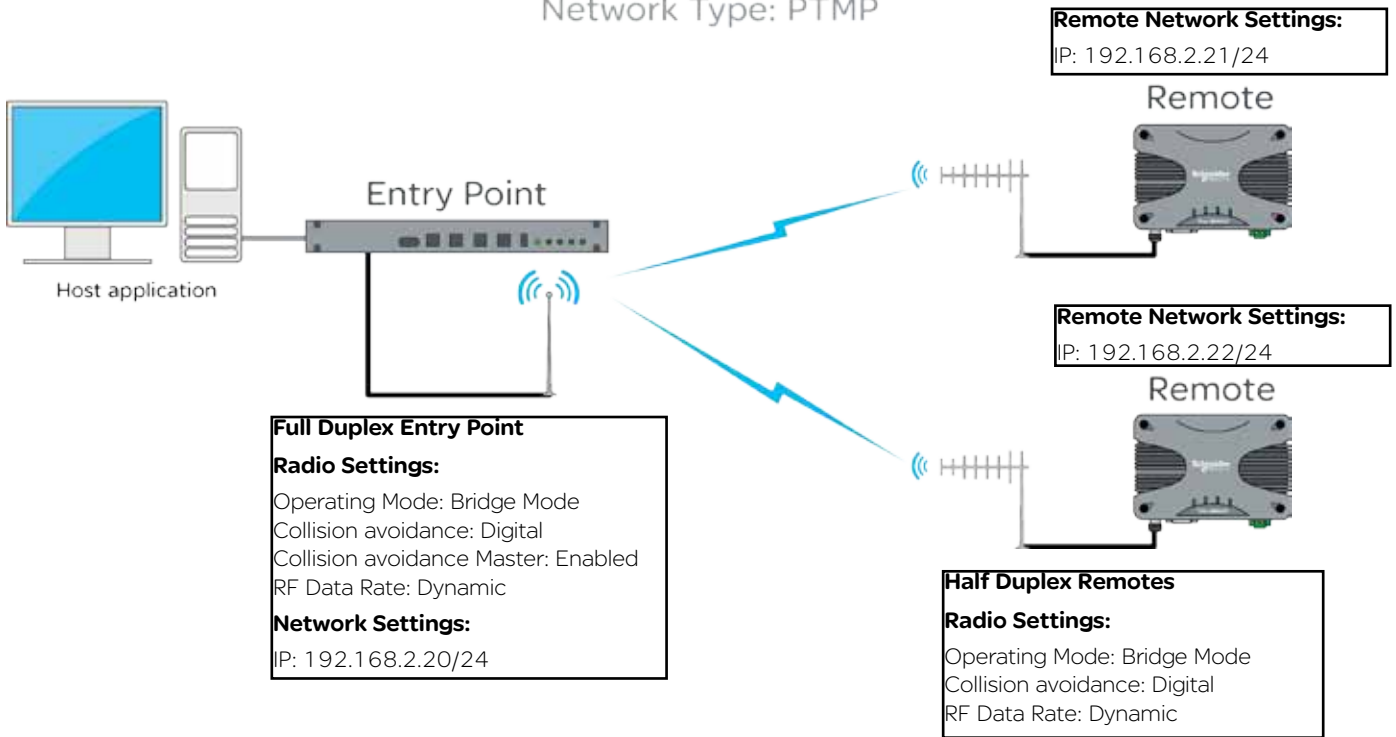

Point to Multipoint - Half Duplex Entry Point

Point to Multipoint

Network Type: PTMP

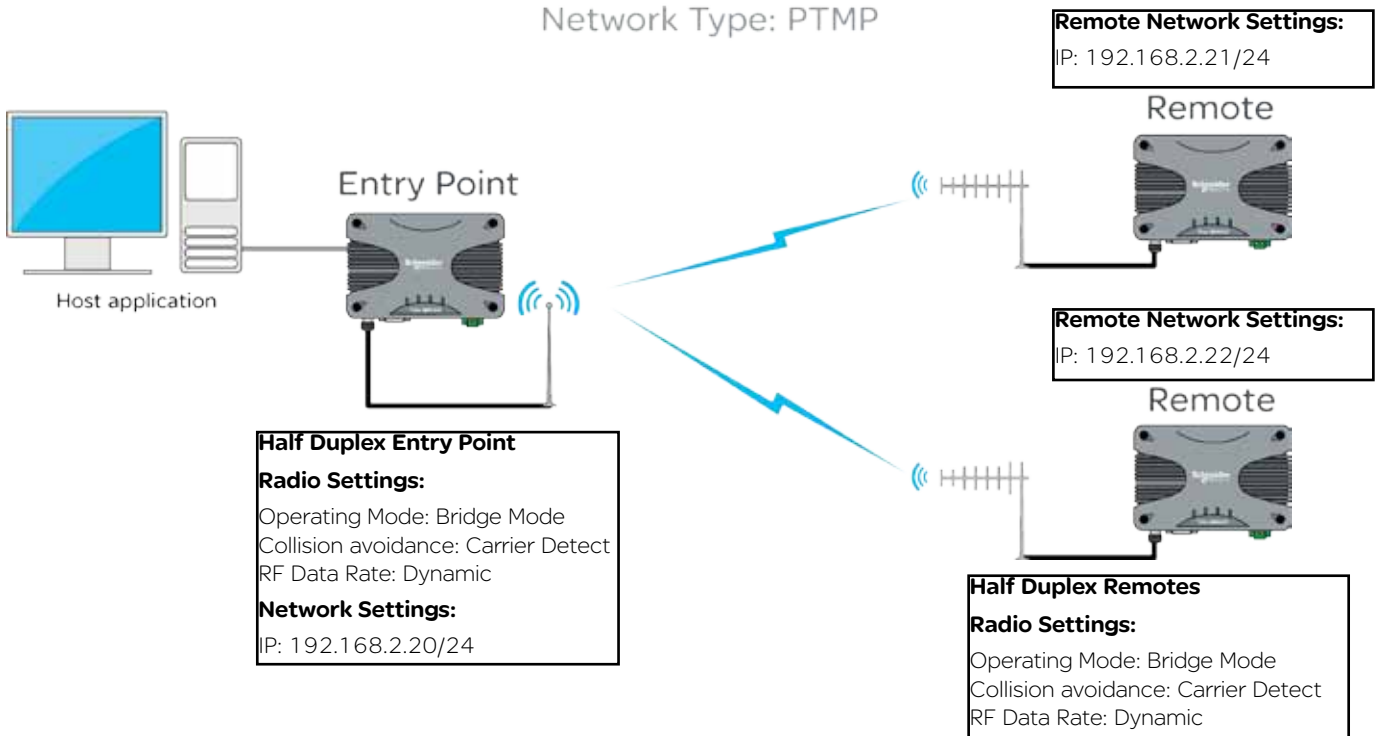

Point to Multipoint via Repeater - Full Duplex Repeater

Point to Multipoint via Repeater

Network Type: PTMP/R

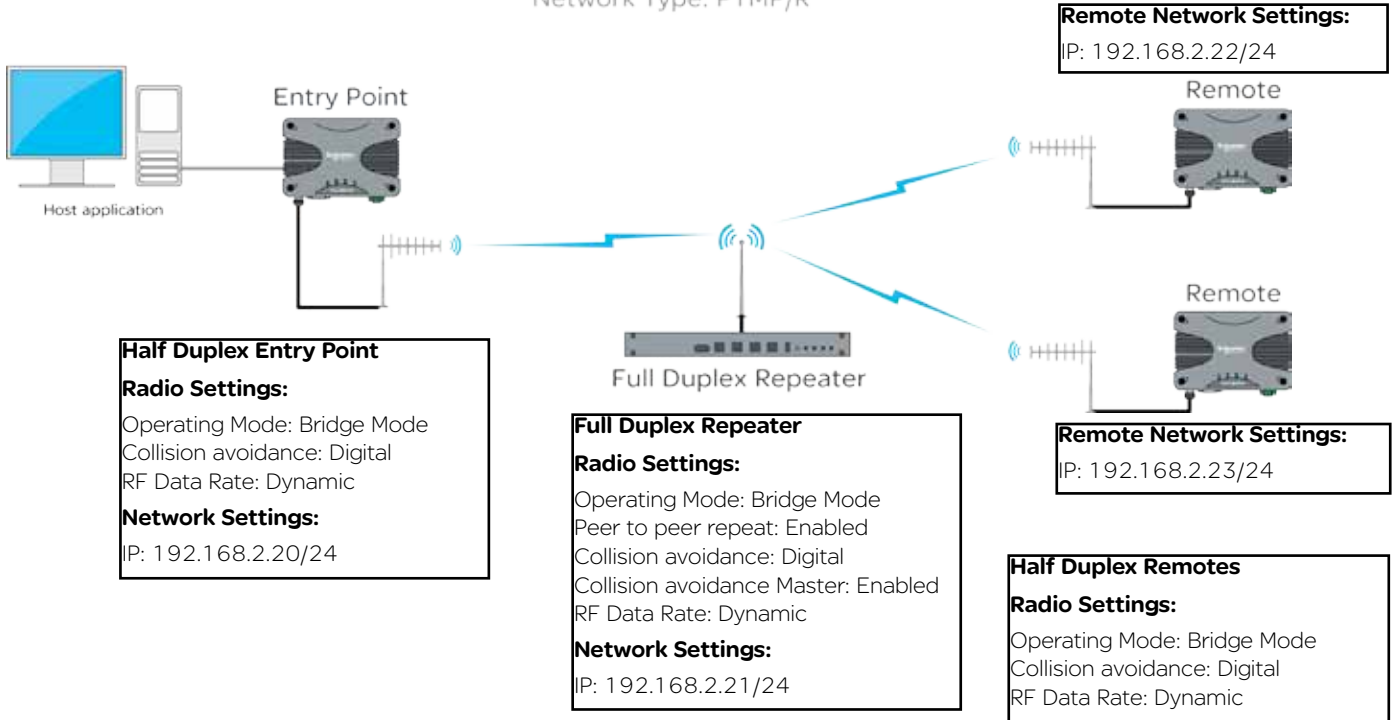

Point to Multipoint via Repeater - Half Duplex Repeater

Point to Multipoint via Repeater

Network Type: PTMP/R

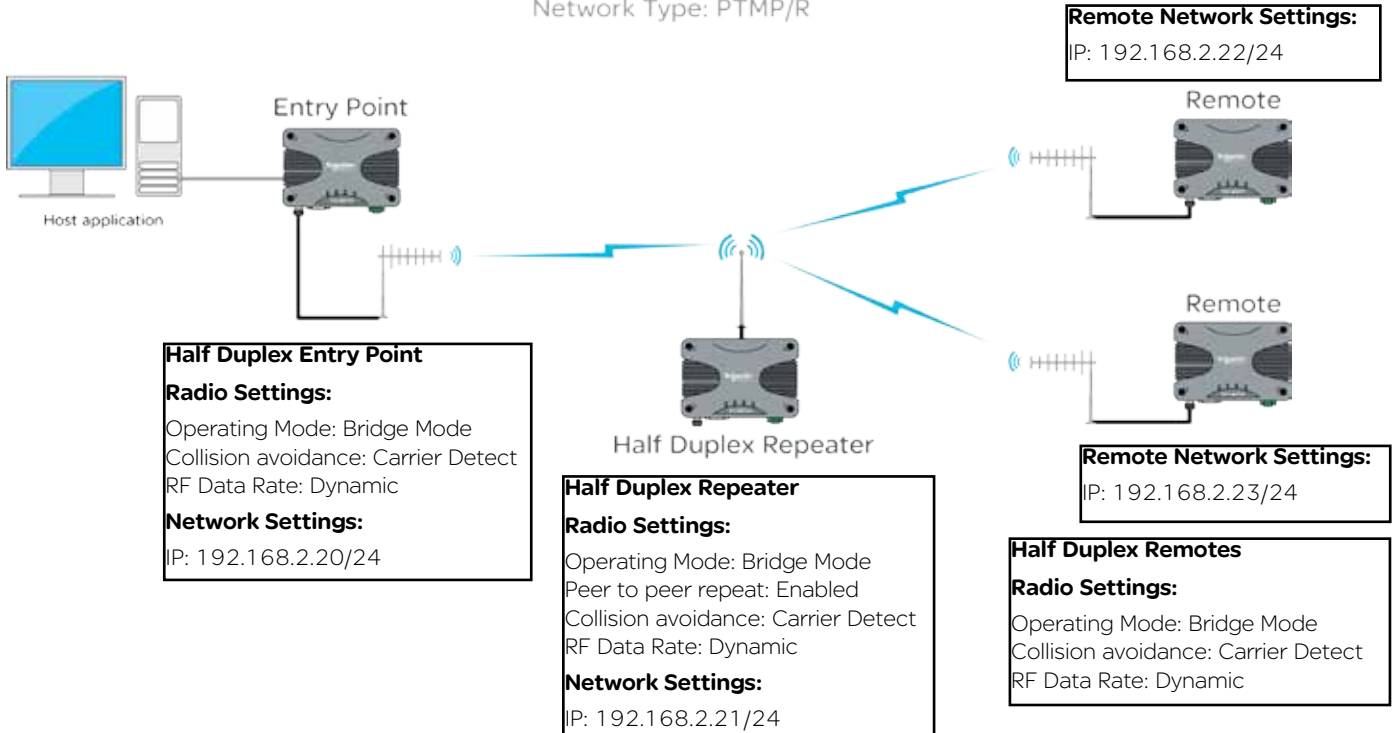

Multipoint to Multipoint

Multipoint to Multipoint (Simplex)

Network Type: MPTMP

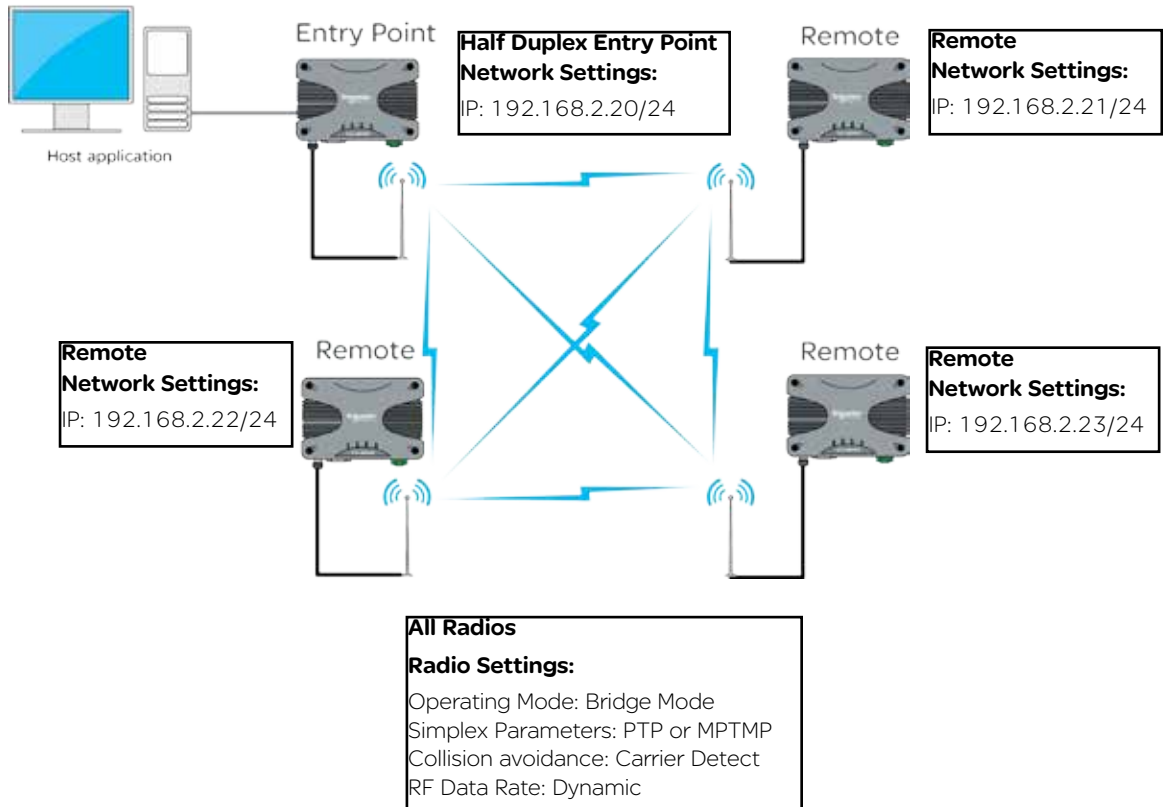

Static Routes

While operating in IP routing mode, a radio must be configured with a manually populated static route table.

That static route table can be accessed via Setup -> IP Routing (only available while radio operating mode is set to IP Routing).

To add a new route to the table, select the 'Add' button. This will add a new, empty table entry, which will need to be manually populated with a static route. The added routes must be populated in an acceptable format. Route formatting information is shown below.

Static Routes

Formatting a static route

There are multiple formatting methods in which static route rules can be written.

Routing rules may define a forwarding path to a gateway or to an interface (LAN or WAN) which is shown in the examples below as <Gateway IP or "LAN" or "WAN">.

Examples:

Using a network address and a subnet mask to define a range of target IP addresses to be forwarded to a gateway

Route Format: <Network Address> <Netmask> <Gateway IP or "LAN" or "WAN">

Example: 192.168.1.0 255.255.255.0 10.10.10.1

Using the CIDR format, a range of IP address may be routed to a specified gateway. The range may include the multicast address space. The network address must be valid (base address of the range) defined by the CIDR prefix.

Route Format: <Network Address/CIDR> <Gateway IP or "LAN" or "WAN">

Example: 192.168.1.0/24 10.10.10.1

A single host or multicast address can be defined and routed to a gateway or an interface as described above.

Route Format: <IP Address> <Gateway IP or "LAN" or "WAN">

Example: 192.168.1.20 10.10.10.1

For each multicast address required to traverse from one interface to another or to effect a store and forward, a route instruction is required. (Where square brackets represent optional route entry parameters.)

Route Format: <Multicast IP Address> [FROM IP Address] "WAN" or "LAN" "WAN" or "LAN" ["WAN" or "LAN"]

Example: 224.240.1.1 192.168.1.40 WAN WAN LAN

There may only be one occurrence of LAN in the rule above.

A second occurrence of WAN will effect a store and forward action.

All routes can also have comments added to them. Comments can be added to the end of each route by prefixing the comment text with an exclamation mark '!'.
Example: 192.168.1.0/24 10.10.10.1 !Mountain Top Route

Router Mode

Introduction

The following Diagrams are designed to provide configuration information on typical topologies. The channel bandwidth and Tx/Rx frequencies are not shown within the diagrams, as they depend on the users license.

The following diagrams show '/24' after an IP address. This short hand addressing indicates the device's subnet mask. '/24' equals a subnet mask of 255.255.255.0. Short hand addressing can be used when writing a static route.

For details on static route formatting, refer to the advanced section of this manual.

Point to Multipoint - Full Duplex Entry Point

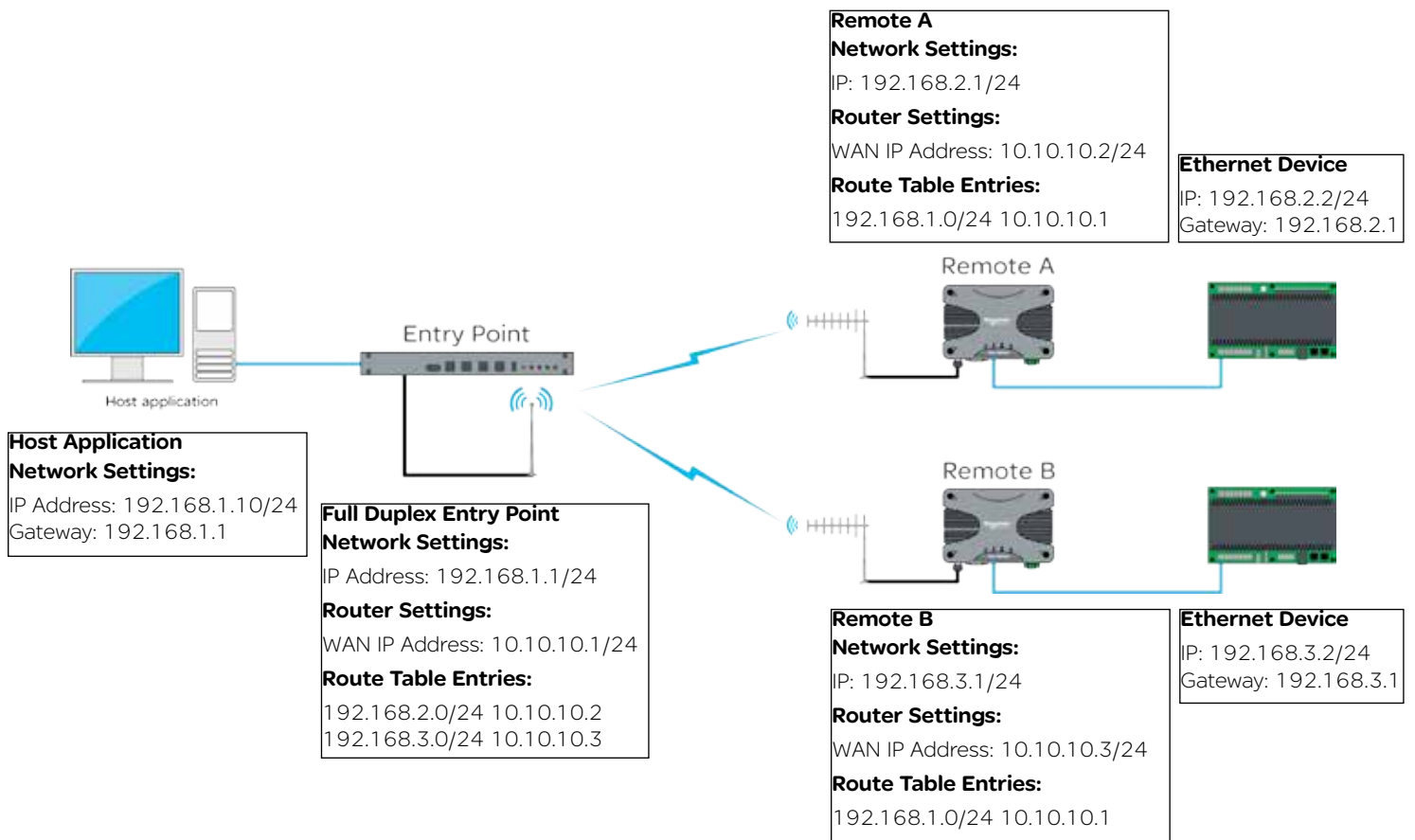

IP Route Configuration Example - Full Duplex Entry Point

In relation to the diagram above (Point to Multipoint - Full Duplex Entry Point) the following example shows how the IP Routing configuration would appear within the Full Duplex Entry Point radio.

IP Routing

WAN IP Address:

WAN Mask:

Static Routes:

192.168.2.0 255.255.255.0 10.10.10.2	Remove
192.168.3.0 255.255.255.0 10.10.10.3	Remove/Add

For detailed information regarding route table entries, refer to the Static Routes section of Part G within this manual.

Point to Multipoint via multiple Repeaters

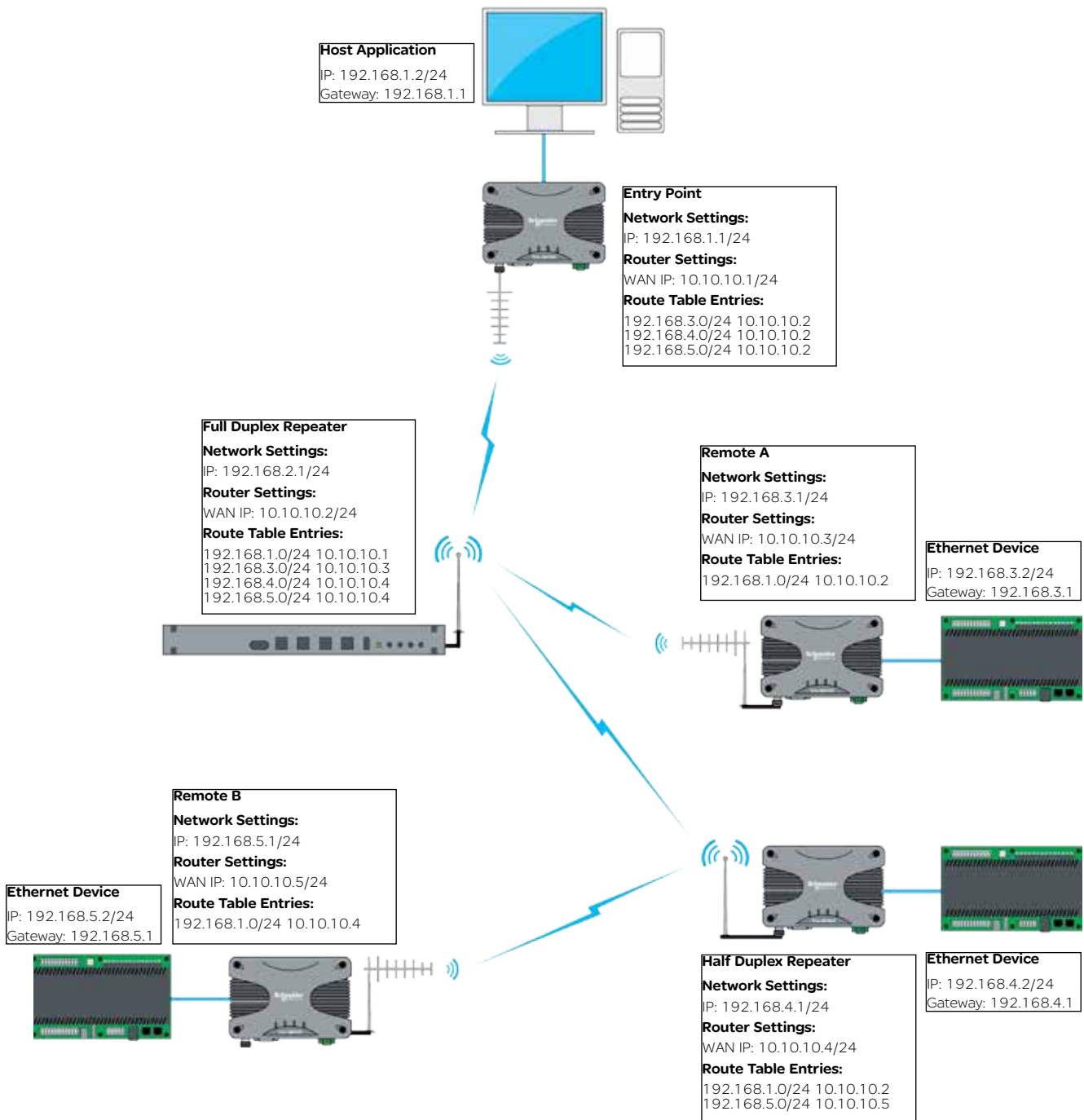

For detailed information regarding route table entries, refer to the Static Routes section of Part G within this manual.

This topology should use Carrier detect collision avoidance.

IP Routing - Serial Data PTMP

As serial data uses the embedded device server (or MODBUS Gateway) the data sent over the air can also be routed. The example below shows a PTMP topology, where the entry point radio is performing the following functions:

- Encapsulating serial data in IP frames.
- Addressing these IP frames to a multicast address.
- Forwarding the multicast frames on to the radio WAN network.

This allows the distribution of the SCADA host’s serial data to be received by all remote radios subscribed to the multicast address and within the subnet of the radio WAN.

To simplify the example, the Character Layer and Interface setting have been shown as default values. These parameters should match the configuration of the external serial device you are connecting to the Q data radio’s Serial Port.

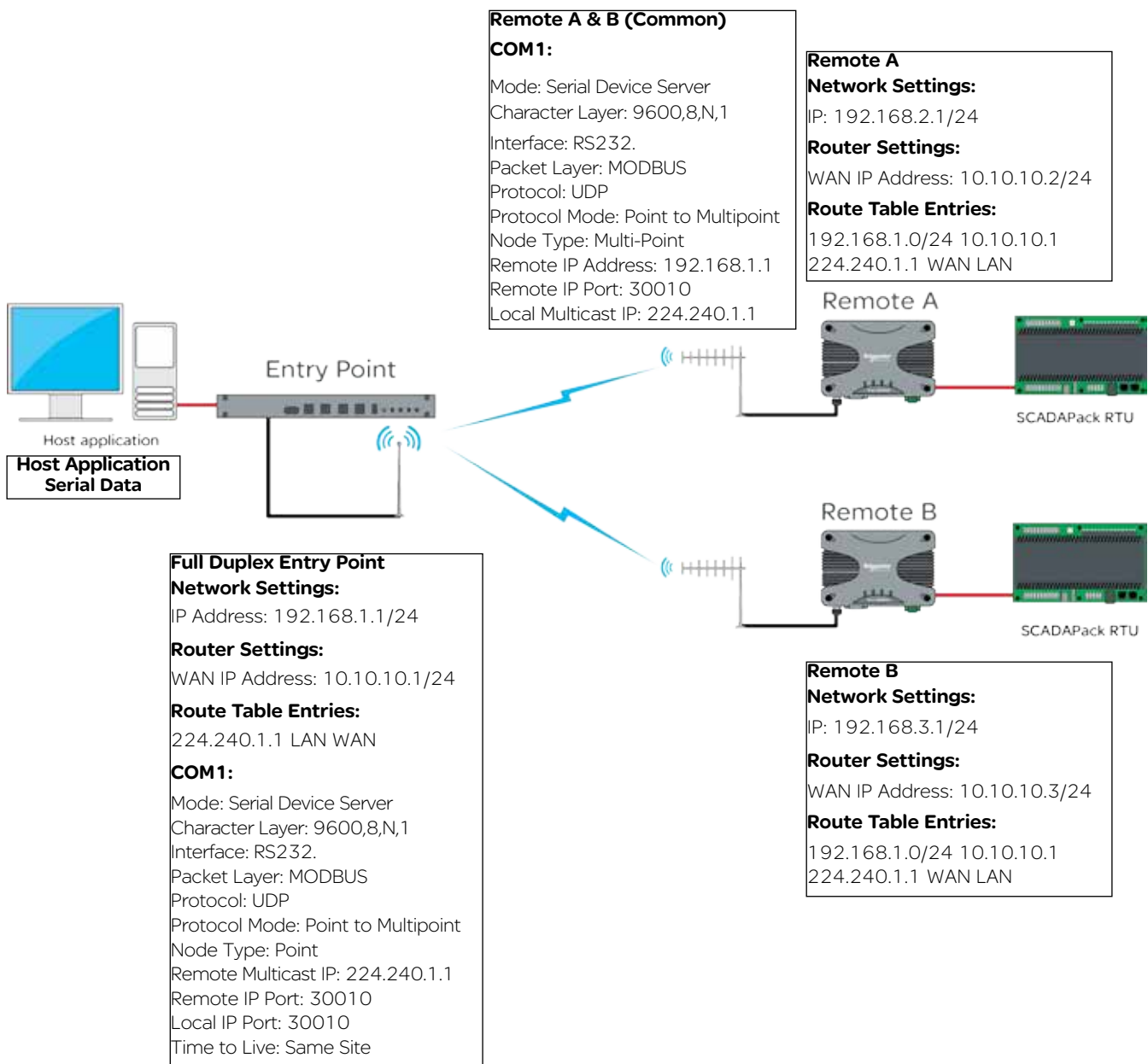

For detailed information regarding route table entries, refer to the Static Routes section of Part G within this manual.

IP Routing - Serial Data PTMP via multiple Repeaters

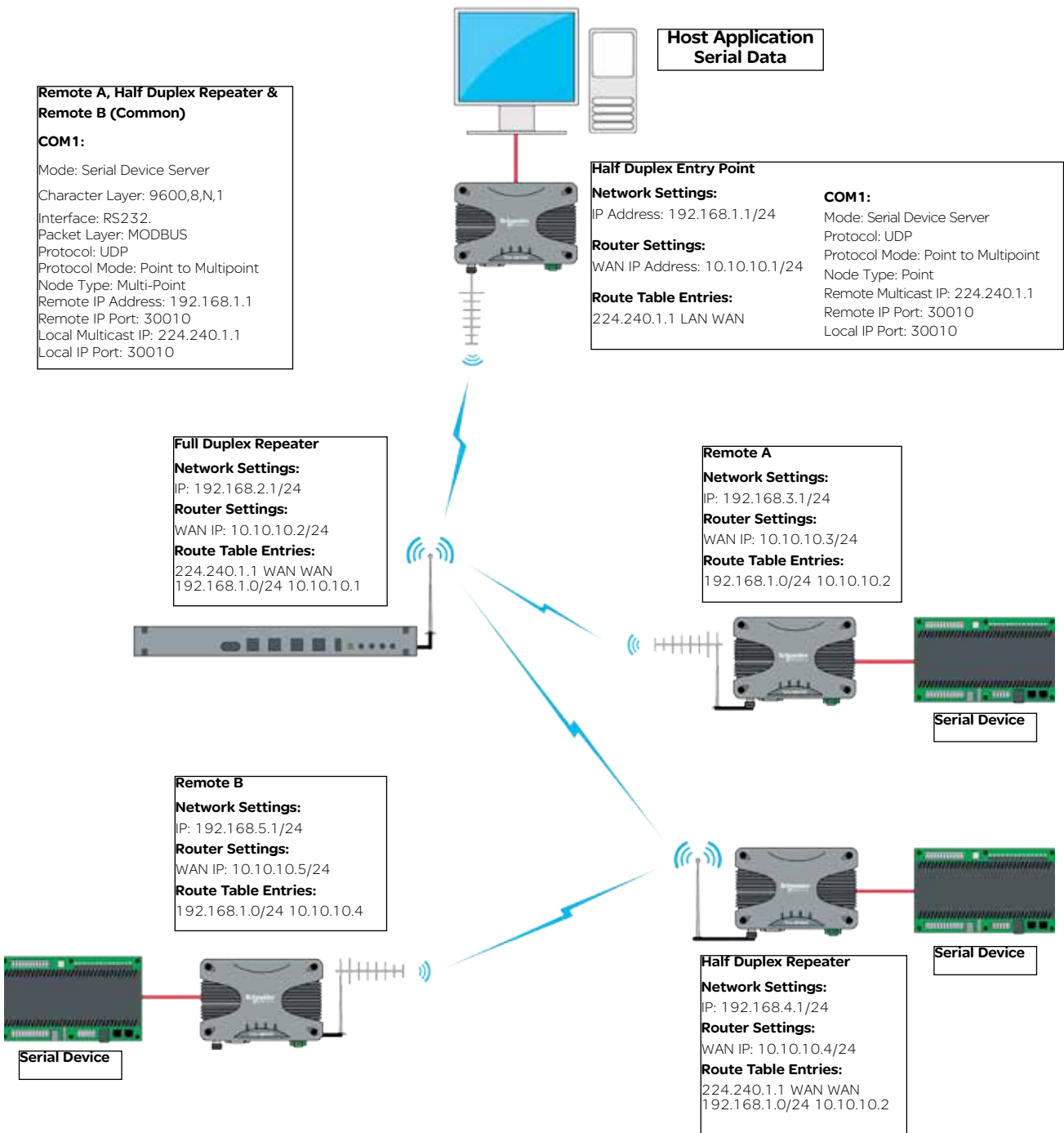

This topology should use Carrier detect collision avoidance.

Network Address Translation (NAT)

Introduction

As of firmware version 1.4.0, Network Address Translation (NAT) is available.

The following Diagrams are designed to provide configuration information on typical topologies. The channel bandwidth and Tx/Rx frequencies are not shown within the diagrams, as they depend on the user's license.

The following diagrams show '/24' after an IP address. This short hand addressing indicates the device's subnet mask. '/24' equals a subnet mask of 255.255.255.0. Short hand addressing can be used when writing a static route.

NAT Configuration

NAT is only available when the radio is operating in IP Routing mode.

NAT configuration parameters can be accessed within the radio's configuration page by browsing to: Setup -> IP Routing.

NAT

Enabled Disabled

Port Forwarding Rules

Enabled	Protocol	WAN Port	LAN Address	LAN Port	Rule Comments	
<input checked="" type="checkbox"/>	ALL ▼	2300	192.168.2.1	23	Telnet	<input type="button" value="Remove"/>
<input type="button" value="Add"/>						

Enable or disable the NAT feature via the Buttons shown above (Enable/Disable). When enabled Port Forwarding Rules become available.

Port Forwarding Rules:

Rules for redirecting a Port on the WAN to a Port on the LAN at the specified LAN Address (250 Max).

- State: [Enable] or [Disable] the rule (1 or 0 in TUI)
- Protocol: Apply to [TCP], [UDP], or [ALL] traffic.
- WAN Port: Listening Port on the WAN interface.
- LAN Address: IP address to redirect traffic to.
- LAN Port: Port at the specified LAN Address to redirect traffic to.
- Rule Comments: Optional notes for the rule (128 Characters Max).

NAT - Point to Multipoint - Full Duplex Entry Point

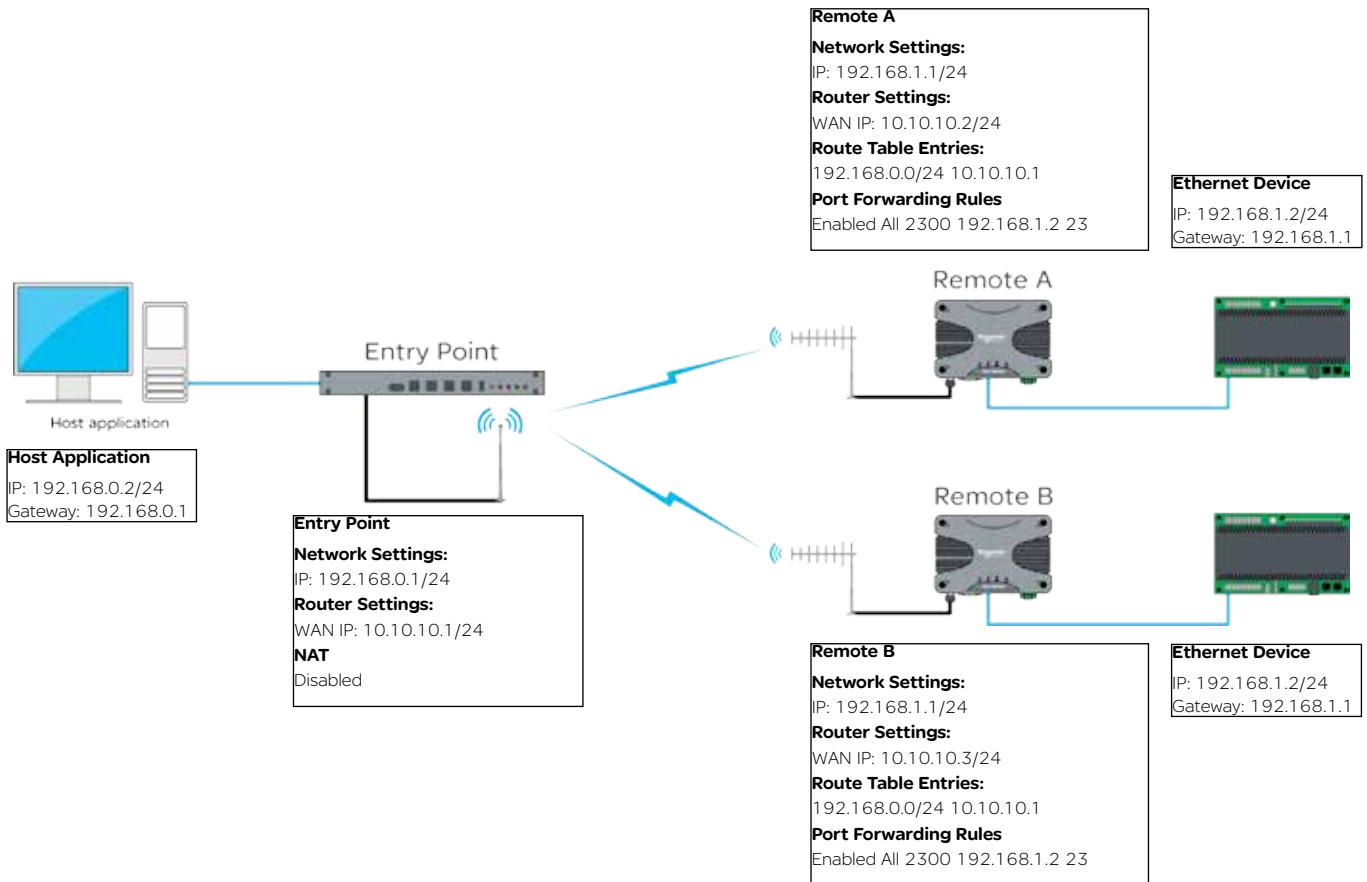

The diagram above provides an example of how to port-forward a Telnet session. In order to establish a Telnet session from the host application, to the Ethernet device connected to Remote A, the host application will have to use the following addressing: [Telnet 10.10.10.2 2300]. This address references Remote A's WAN IP and the unique port number allocated to the Ethernet device specified within the port forwarding rule.

NAT - Point to Multipoint via multiple Repeaters

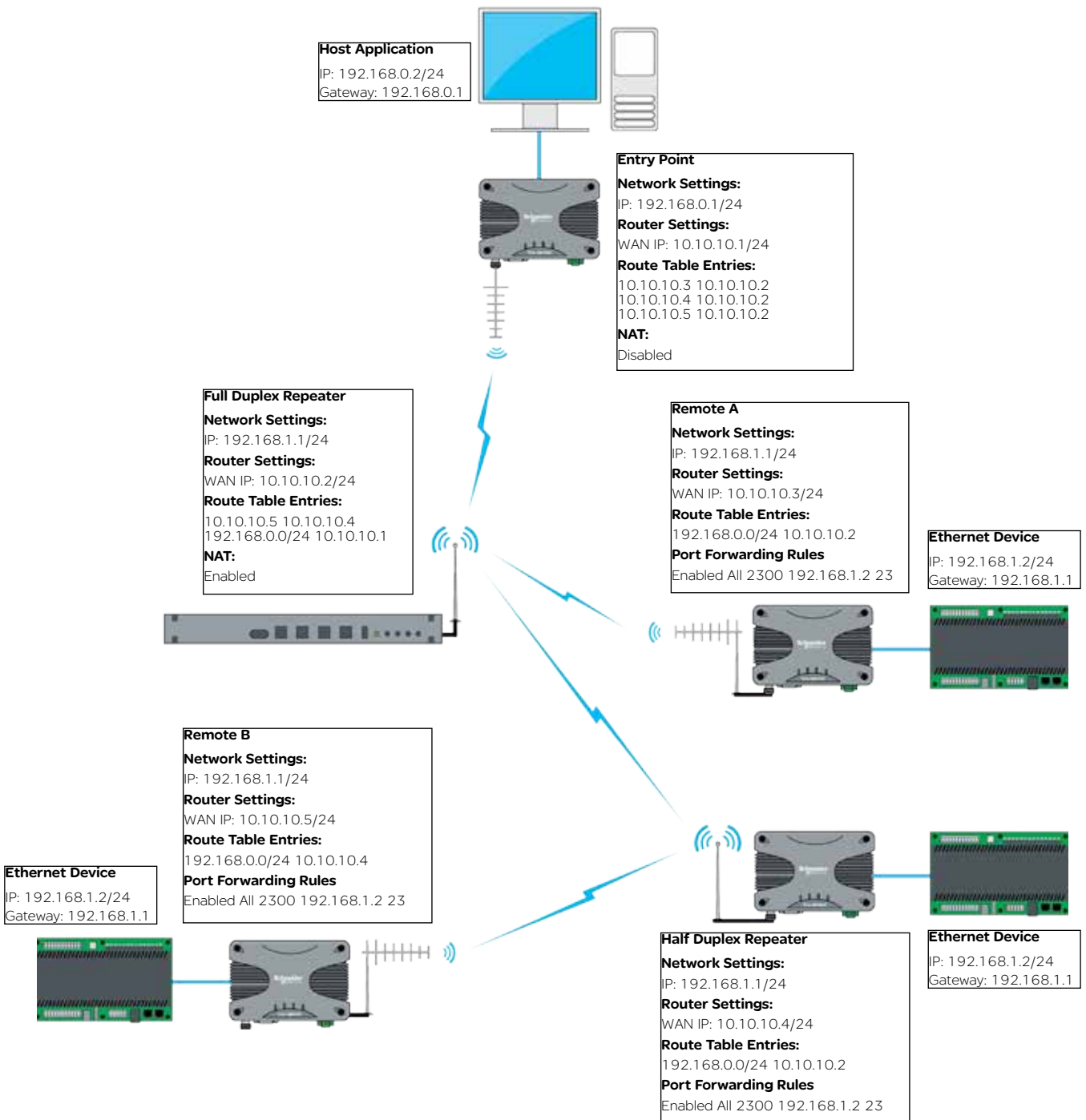

The diagram above provides an example of how to port-forward a Telnet session from the Host application, to an Ethernet device shown. In order to establish a Telnet session from the host application to the Ethernet device connected to Remote A, the host application requires the following addressing: [Telnet 10.10.10.3 2300]. This address references Remote A's WAN IP and the unique port number allocated to the Ethernet device specified within the port forwarding rule.

This topology should use Carrier detect collision avoidance.

Virtual LAN (VLAN)

Introduction

As of firmware version 1.5.0, VLAN is available (in Transparent Bridge mode only).

VLAN can help provide isolation between separate entities who share a single network.

For example, Department A may require access to the radios configuration/Diagnostics, while Department B may only require access to SCADA information. By implementing VLAN, a virtual network segregation can be implemented to help isolate each of the departments from one another.

VLAN Configuration

To access the VLAN configuration section, browse to: Setup -> VLAN.

By default, VLAN is disabled. To enable VLAN, select 'Enabled'. The configurable range of each VLAN is 1 - 4094.

General

VLAN

Enabled Disabled

Radio Services VLAN

Management VLAN ID:

Defines the VLAN ID for access to radio management services. Management services include HTTP/S, Telnet, SSH, SNMP and eDiags. A minimum of one Ethernet interface must be a member of this VLAN to ensure that radio management services can be accessed. (Default = 1).

SCADA VLAN:

Enables a separate VLAN for radio SCADA services. SCADA services include serial device server & MODBUS gateway. Allows external serial devices to be connected to COM1/2 and belong to a separate SCADA VLAN. Once enabled, additional configuration options become available:

- **SCADA VLAN ID:** SCADA VLAN ID is normally the same VLAN ID defined for SCADA traffic on the Ethernet interface. Default value is 2.
- **SCADA VLAN IP Address:** Defines the unique IP address for the Serial Device Server/MODBUS Gateway when they belong to the SCADA VLAN.
- **SCADA VLAN Subnet Mask:** Defines the subnet mask for the SCADA VLAN. This determines which IP addresses are local to the device, and which should be reached through a gateway or router
- **COM1 VLAN:** Defines the VLAN that the serial device server/MODBUS Gateway using COM1 belongs to. (If SCADA VLAN is disabled, this defaults to Management)
 - Management: Service on serial port COM1 will be assigned to the management VLAN
 - SCADA: Service on serial port COM1 will be assigned to the SCADA VLAN.
- **COM2 VLAN:** Defines the VLAN that the serial device server/MODBUS Gateway using COM2 belongs to. (If SCADA VLAN is disabled, this defaults to Management)
 - Management: Service on serial port COM2 will be assigned to the management VLAN.
 - SCADA: Service on serial port COM2 will be assigned to the SCADA VLAN.

Ethernet Ports (VLAN)

Each Ethernet port can be independently configured to operate in one of two modes: Access or Trunk.

Access: a port in access mode will process un-tagged packets from the Ethernet interface, append the corresponding Port VLAN ID (PVID) and send the packets over the radio channel. When a packet is received on the radio channel, the packet's VLAN tag will be examined, and if it matches the user configured PVID for any Ethernet port on the radio, the tag will be removed and sent out the corresponding port.

A port configured in access mode, requires a Port VLAN ID (PVID).

Access ports configured with a PVID which match the management services VLAN will provide access to internal radio management services.

Trunk: a port in trunk mode will transmit tagged VLAN packets from the Ethernet interface over the radio channel. If an un-tagged packet is received on the port, it will be discarded.

Filtering can be applied to a trunk port, to allow only select VLAN IDs to pass through the port.

Ingress Filtering, when enabled, applies filtering on VLAN packets processed on any Ethernet port configured as a trunk port. The filter will discard all VLAN tagged packets which are not found within the membership table (for the corresponding port) while, allowing VLAN tagged packets within the membership table to be sent over the radio channel. When Disabled, the Ethernet interface will pass all tagged VLAN packets over the radio channel.

Membership

VLAN Membership:

For trunked ports with ingress filtering enabled, VLAN IDs not defined in the table are discarded.

- State: [Enable] or [Disable] the VLAN
- VID: VLAN ID (1-4094).
- ETH1: Include ETH1 in this VLAN. Can not be enabled if ETH1 is an access port.
- ETH2: Include ETH2 in this VLAN. Can not be enabled if ETH2 is an access port.
- Description: Description of the VLAN (128 Characters Max).

VLAN - PTMP via Repeater

The following Diagrams are designed to provide VLAN configuration information on typical topologies. The channel bandwidth and Tx/Rx frequencies are not shown within the diagrams, as they depend on the user's license.

The following examples require a prerequisite understanding of VLAN functionality.

Example 1: Access Port

The following example shows the configuration of VLAN required to isolate different hosts residing on the same network.

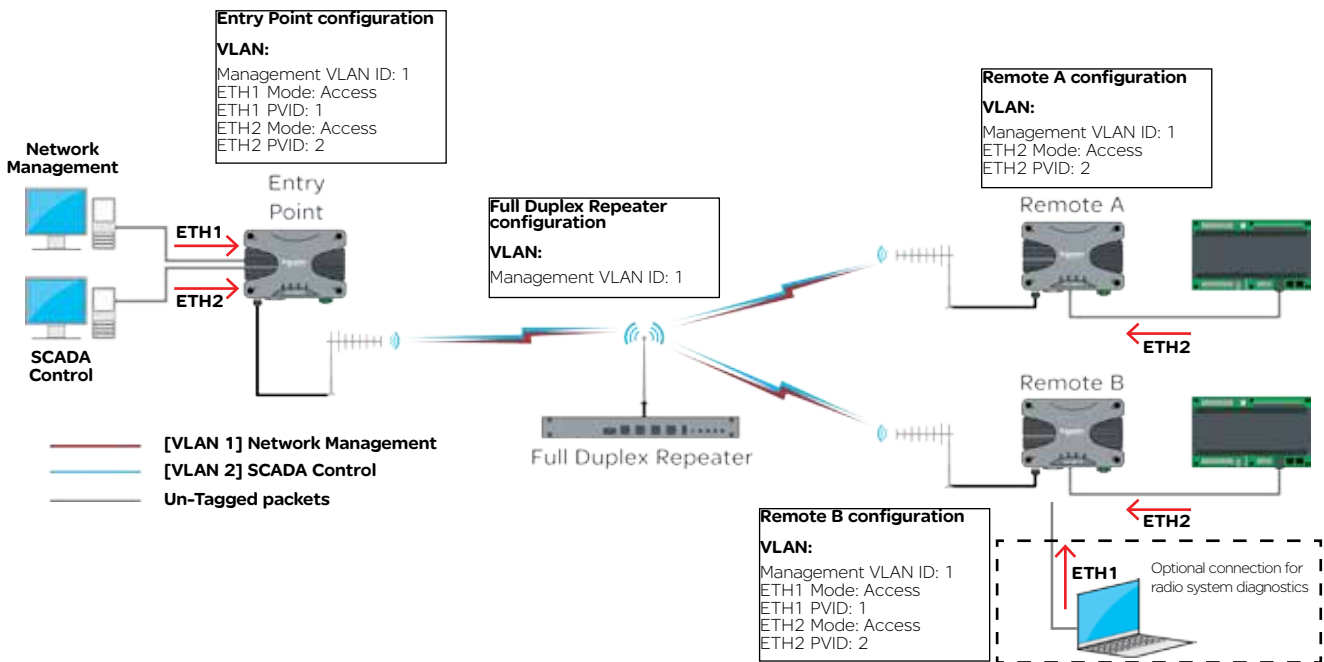

The Network Management Host is connected to the ETH1 interface of the Entry Point radio. Via this interface, the Network Management Host will reside on VLAN 1 (over the radio network). As the Management VLAN ID of each radio is a member of VLAN 1, the Network Management Host will have access to radio services including: HTTP/S, Telnet, SSH, SNMP & eDiags.

The SCADA Control Host is connected to the ETH2 interface of the Entry Point radio. Via this interface, the SCADA Control Host will reside on VLAN 2 (over the radio network). As the remote radio's ETH2 interface is a member of VLAN 2, the SCADA Control Host will have access to the SCADA devices connected to the ETH2 interface of the remote radios.

In this example, the Network Management Host does not have access to the SCADA devices (as they are connected to the ETH2 interface of the remote radios, which is a member of VLAN 2), while the SCADA Control Host does not have access to radio services, as they reside on VLAN 1.

Example 2: Trunk Port

The following example shows the configuration of VLAN required to allow pre-tagged VLAN packets, to be sent over the radio network.

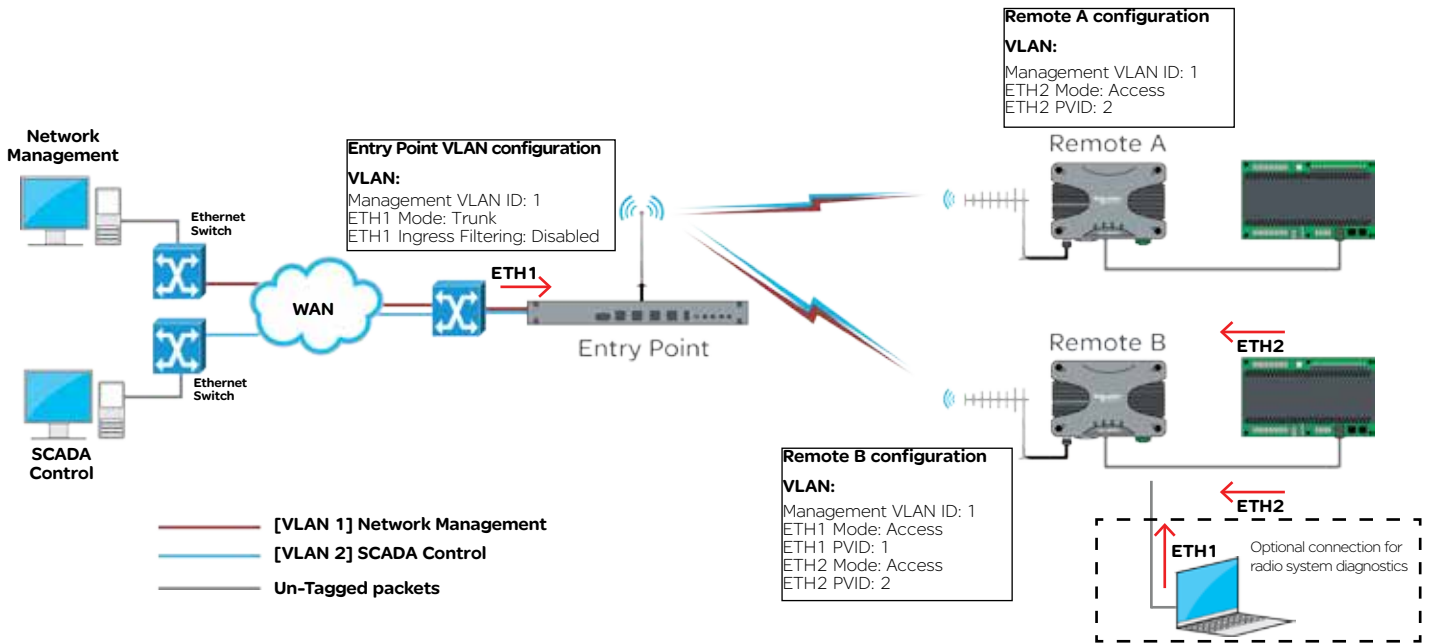

Pre-tagged VLAN packets are sent into each port of the entry point radio. This example shows managed Ethernet switches performing the VLAN tagging.

The entry point radio is configured to trunk VLAN 1 & VLAN 2 on the ETH1 interface.

As packets from the Network Management Host are being tagged on VLAN 1 (by the managed switch) and the Management VLAN ID of each radio is a member of VLAN 1, the Network Management Host will have access to radio services including: HTTP/S, Telnet, SSH, SNMP & eDiags.

As packets from the SCADA Control Host are being tagged on VLAN 2 (by the managed switch) and the remote radio’s ETH2 interface is a member of VLAN 2, the SCADA Control Host will have access to the SCADA devices connected to the ETH2 interface of the remote radios.

In this example, the Network Management Host does not have access to the SCADA devices (as they are connected to the ETH2 interface of the remote radios, which is a member of VLAN 2), while the SCADA Control Host does not have access to radio services, as the managed switch has tagged them on VLAN 1.

Example 3: Trunk Port & Access Port

A mixture of the preceding examples can be implemented on the radio network. In this circumstance, the trunk port will not allow the VLAN which the Access port is a member of, unless specified in the membership table.

Serial and MODBUS

Introduction

Point to Point serial connectivity can be achieved by using the serial device server embedded within the Q data radios radio. The serial device server has three protocols available, each with their own benefits:

TCP: Establishes a session based connection, providing high reliability on data delivery.

UDP: Consumes low bandwidth and provides a low latency connection.

PPP: Provides a virtual Ethernet connection over a serial link.

Serial data transport via TCP

Connect the PC's Ethernet port to ETH1 or ETH2 of the radio being configured and using a web browser, browse to the radio's configuration page by entering the IP address the unit into the browser's URL bar. Once the configuration has been activated, repeat the process for the remaining radio.

To access the parameters below, browse to the "Setup" tab and select the "COM1" option under "Configuration".

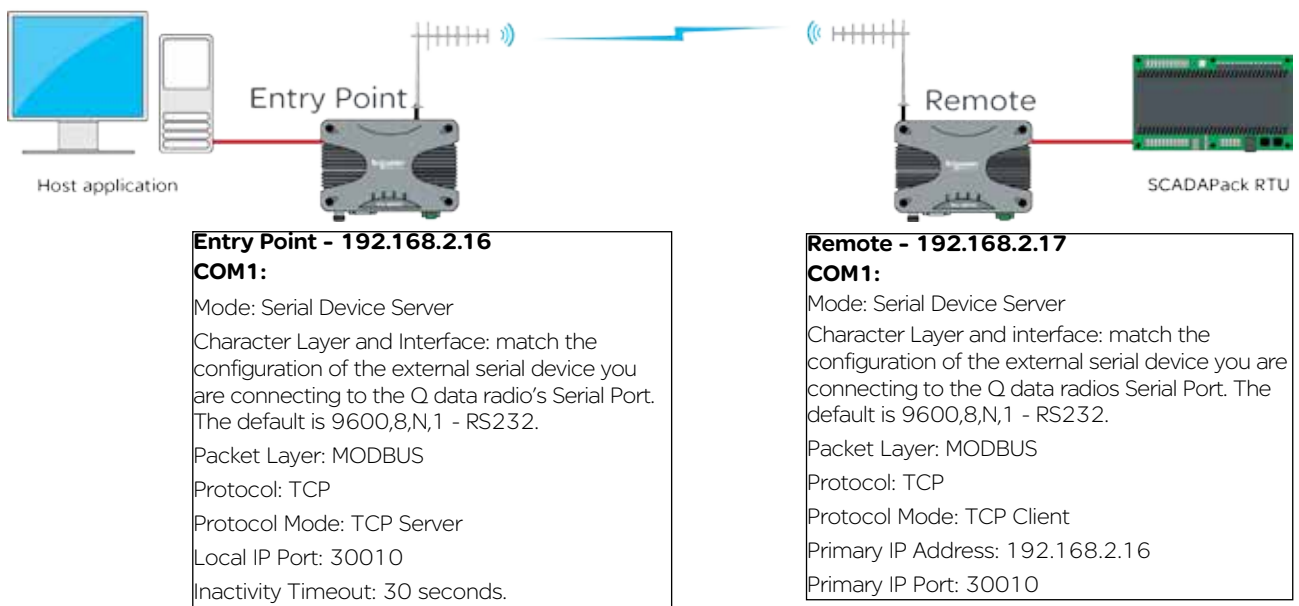

Serial data transport via UDP

Connect the PC's Ethernet port to ETH1 or ETH2 of the radio being configured and using a web browser, browse to the radio's configuration page by entering the IP address the unit into the browser's URL bar. Once the configuration has been activated, repeat the process for the remaining radio.

To access the parameters below, browse to the "Setup" tab and select the "COM1" option under "Configuration".

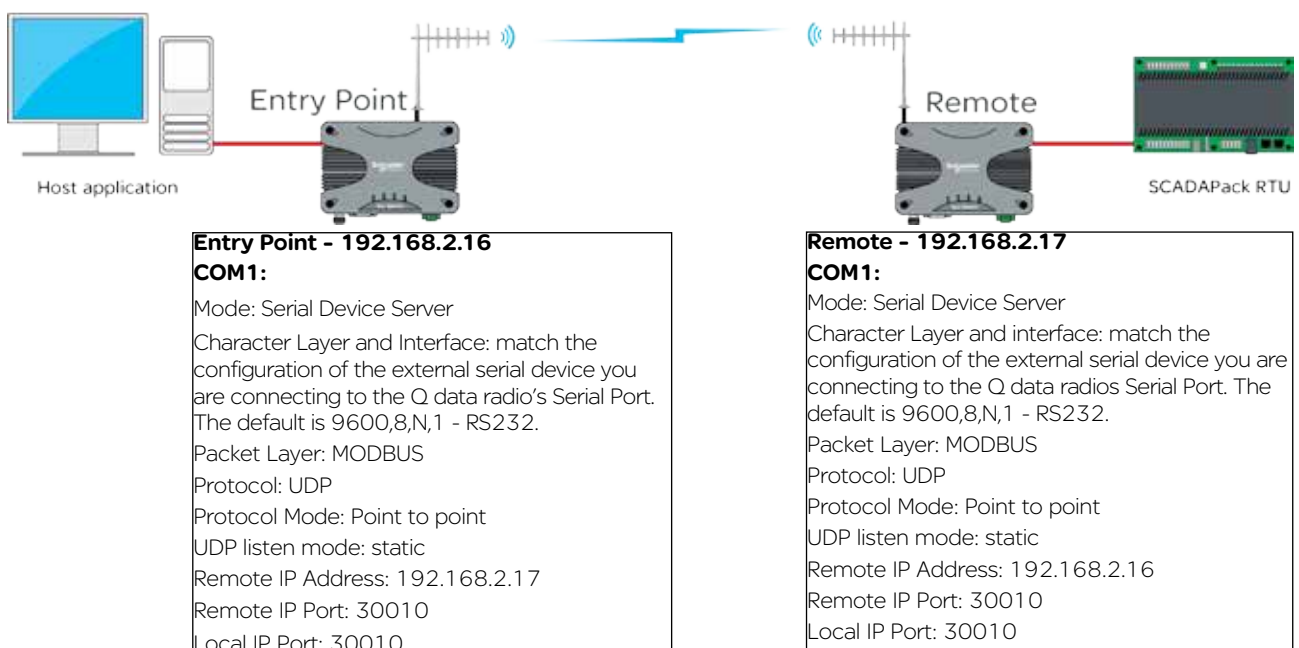

Serial data transport via PPP

Connect the PC's Ethernet port to ETH1 or ETH2 of the radio being configured and using a web browser, browse to the radio's configuration page by entering the IP address the unit into the browser's URL bar. Once the configuration has been activated, repeat the process for the remaining radio.

To access the parameters below, browse to the "Setup" tab and select the "COM1" option under "Configuration".

The example uses the following IP addresses for external PPP Clients: 'Host Application - 192.168.2.20' 'External Device (RTU) - 192.168.2.30'

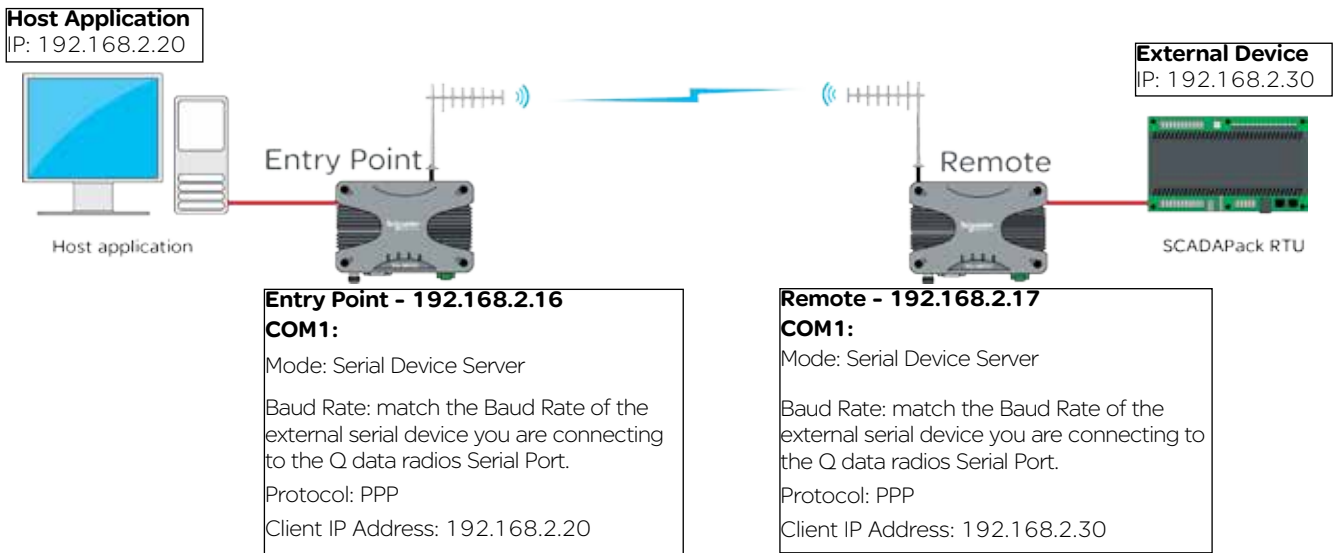

Point to Multipoint Serial to Serial Link Setup

Introduction

Point to Multipoint serial connectivity can be achieved by using the serial device server embedded within the Q data radios. The serial device server can be used in UDP mode, to achieve a point to multipoint serial link.

Serial data transport via UDP

Connect the PC's Ethernet port to ETH1 or ETH2 of the radio being configured and using a web browser, browse to the radio's configuration page by entering the IP address the unit into the browser's URL bar. Once the configuration has been activated, repeat the process for the remaining radio/s.

To access the parameters below, browse to the "Setup" tab and select the "COM1" option under "Configuration".

The allocated IP addresses for this example are 'Entry Point- 192.168.2.16', 'Remote A - 192.168.2.17', 'Remote B - 192.168.2.18'.... (additional remotes can use incremental IP allocation from Remote B).

Entry Point - 192.168.2.16
COM1:
 Mode: Serial Device Server
 Character Layer and Interface: match the configuration of the external serial device you are connecting to the Q data radios Serial Port. The default is 9600,8,N,1 - RS232.
 Packet Layer: MODBUS
 Protocol: UDP
 Protocol Mode: Point to Multipoint
 Node Type: Point
 Remote Multicast IP Address: 224.240.1.1
 Remote IP Port: 30010
 Local IP Port: 30010

Remote A - 192.168.2.17
COM1:
 Mode: Serial Device Server
 Character Layer and interface: match the configuration of the external serial device you are connecting to the Q data radios Serial Port. The default is 9600,8,N,1 - RS232.
 Packet Layer: MODBUS
 Protocol: UDP
 Protocol Mode: Point to Multipoint
 Node Type: Multi-Point
 Remote IP Address: 192.168.2.16
 Remote IP Port: 30010
 Local Multicast IP Address: 224.240.1.1
 Local IP Port: 30010

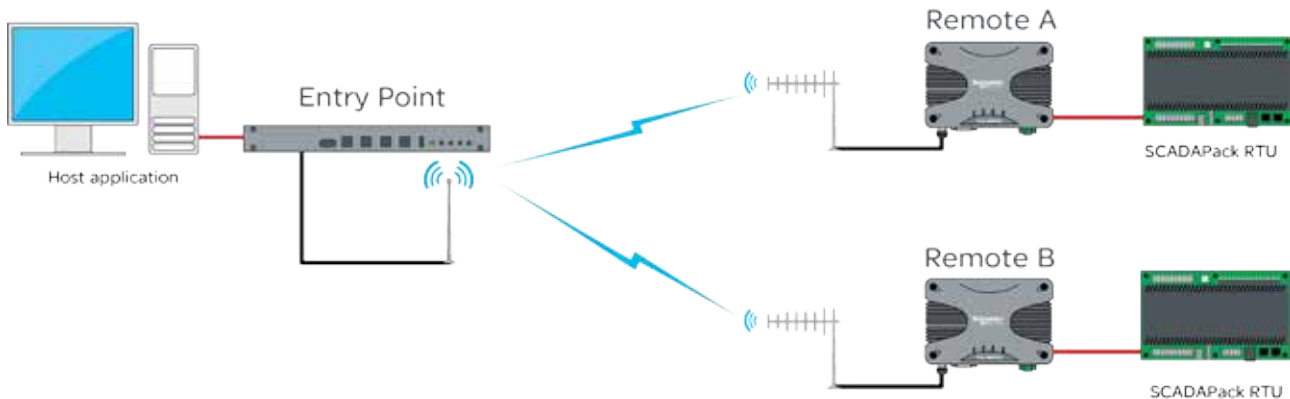

Remote B - 192.168.2.18
COM1:
 Mode: Serial Device Server
 Character Layer and interface: match the configuration of the external serial device you are connecting to the Q data radios Serial Port. The default is 9600,8,N,1 - RS232.
 Packet Layer: MODBUS
 Protocol: UDP
 Protocol Mode: Point to Multipoint
 Node Type: Multi-Point
 Remote IP Address: 192.168.2.16
 Remote IP Port: 30010
 Local Multicast IP Address: 224.240.1.1
 Local IP Port: 30010

MODBUS Gateway

Introduction

Point-to-Point (PTP) with MODBUS TCP to MODBUS RTU can be performed by using the MODBUS gateway feature embedded within the Q data radios.

MODBUS TCP to MODBUS RTU - Point to point

Connect the PC's Ethernet port to ETH1 or ETH2 of the radio being configured and using a web browser, browse to the radio's configuration page by entering the IP address the unit into the browser's URL bar. Once the configuration has been activated, repeat the process for the remaining radio/s.

To access the parameters below, browse to the "Setup" tab and select the "COM1" option under "Configuration".

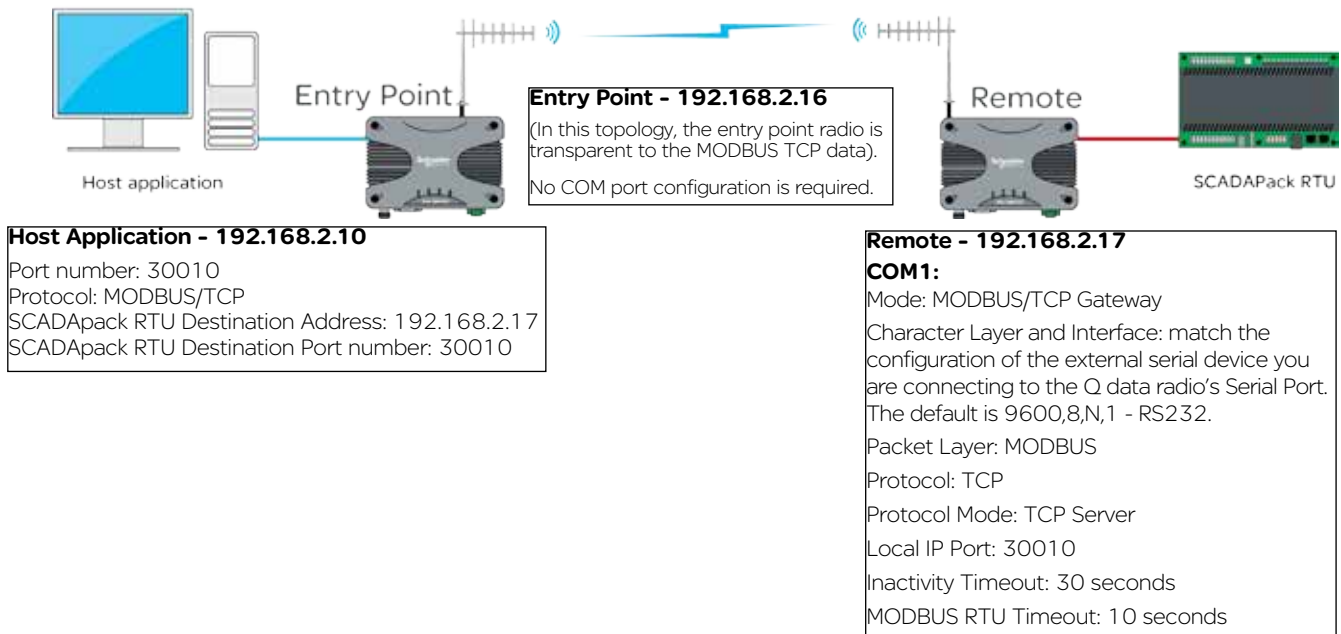

MODBUS TCP to MODBUS RTU - Point to multipoint

Introduction

Point to multipoint (PTMP) with MODBUS TCP to MODBUS RTU can be performed by using the MODBUS gateway feature embedded within the Q data radios.

MODBUS TCP to MODBUS RTU - Point to multipoint

Connect the PC's Ethernet port to ETH1 or ETH2 of the radio being configured and using a web browser, browse to the radio's configuration page by entering the IP address the unit into the browser's URL bar. Once the configuration has been activated, repeat the process for the remaining radio/s.

To access the parameters below, browse to the "Setup" tab and select the "COM1" option under "Configuration".

Host Application - 192.168.2.10
 Port number: 30010
 Protocol: MODBUS/TCP
 Site A - RTU Destination Address: 192.168.2.17
 Site A - RTU Destination Port number: 30010
 Site B - RTU Destination Address: 192.168.2.18
 Site B - RTU Destination Port number: 30010

Remote A - 192.168.2.17
COM1:
 Mode: MODBUS/TCP Gateway
 Character Layer and Interface: match the configuration of the external serial device you are connecting to the Q data radio's Serial Port. The default is 9600,8,N,1 - RS232.
 Packet Layer: MODBUS
 Protocol: TCP
 Protocol Mode: TCP Server
 Local IP Port: 30010
 Inactivity Timeout: 30 seconds.
 MODBUS RTU Timeout: 10 seconds

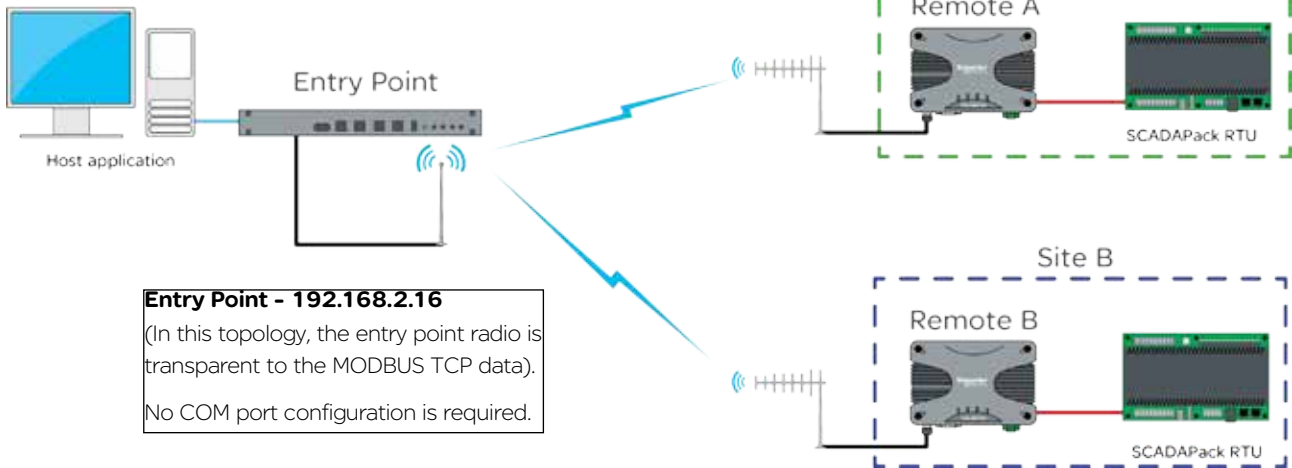

Entry Point - 192.168.2.16
 (In this topology, the entry point radio is transparent to the MODBUS TCP data).
 No COM port configuration is required.

Remote B - 192.168.2.18
COM1:
 Mode: MODBUS/TCP Gateway
 Character Layer and Interface: match the configuration of the external serial device you are connecting to the Q data radio's Serial Port. The default is 9600,8,N,1 - RS232.
 Packet Layer: MODBUS
 Protocol: TCP
 Protocol Mode: TCP Server
 Local IP Port: 30010
 Inactivity Timeout: 30 seconds.
 MODBUS RTU Timeout: 10 seconds

Single Frequency (Simplex) Mode

Introduction

Half Duplex Trio Q data radios can operate in a single frequency (Simplex) mode. This means the transmitting and receiving frequencies are the same single frequency. See the diagram below. (The frequencies shown are for example purposes only).

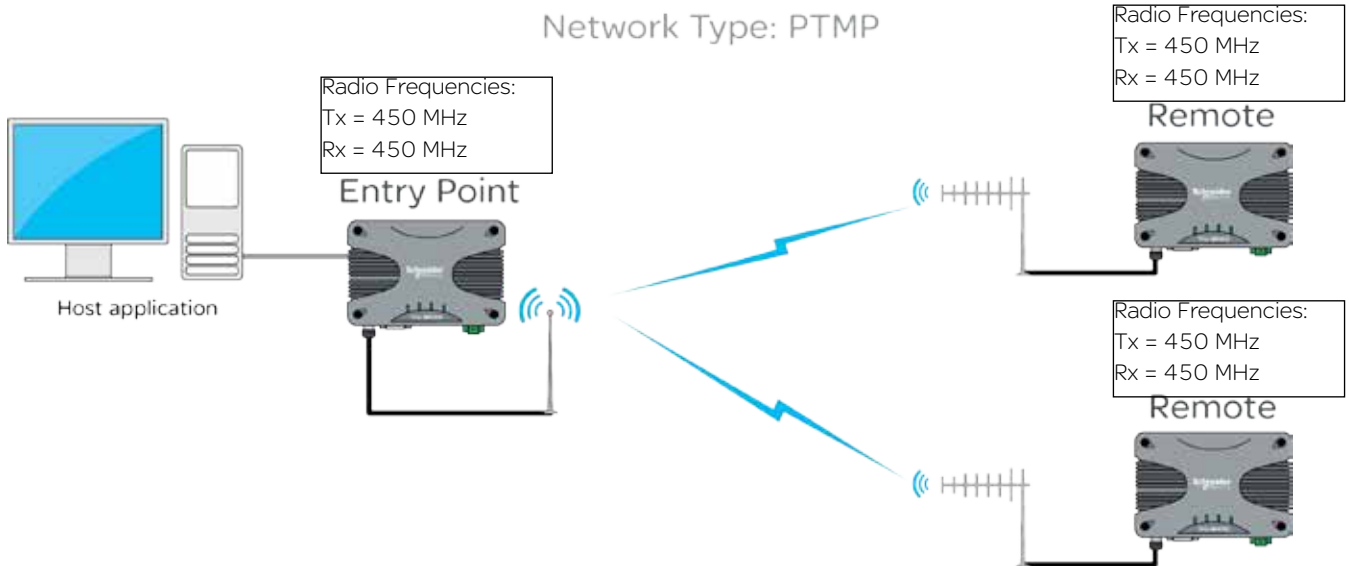

Configuration

Single frequency operation also requires parameters to be configured which relate to the system topology.

System Topology: Select between Point to Multipoint (PTMP), Point to Multipoint via Repeater (PTMP via Repeater) or Point to Point (PTP). Every radio in a simplex radio system should have same system topology selected.

System Topology

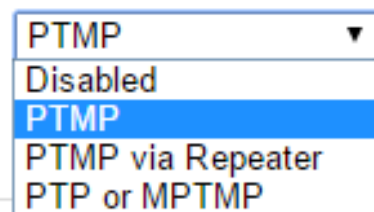

Topology Function: Each radio in a simplex radio system will have its own topology function. Select between Entry Point, Repeater or Remote.

Topology Function

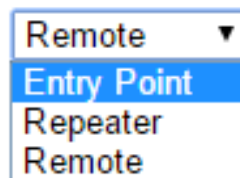

Simplex PTMP via Repeater

Point to multipoint via repeater(PTMP/R) in simplex mode can be performed. See the diagram below for an example:

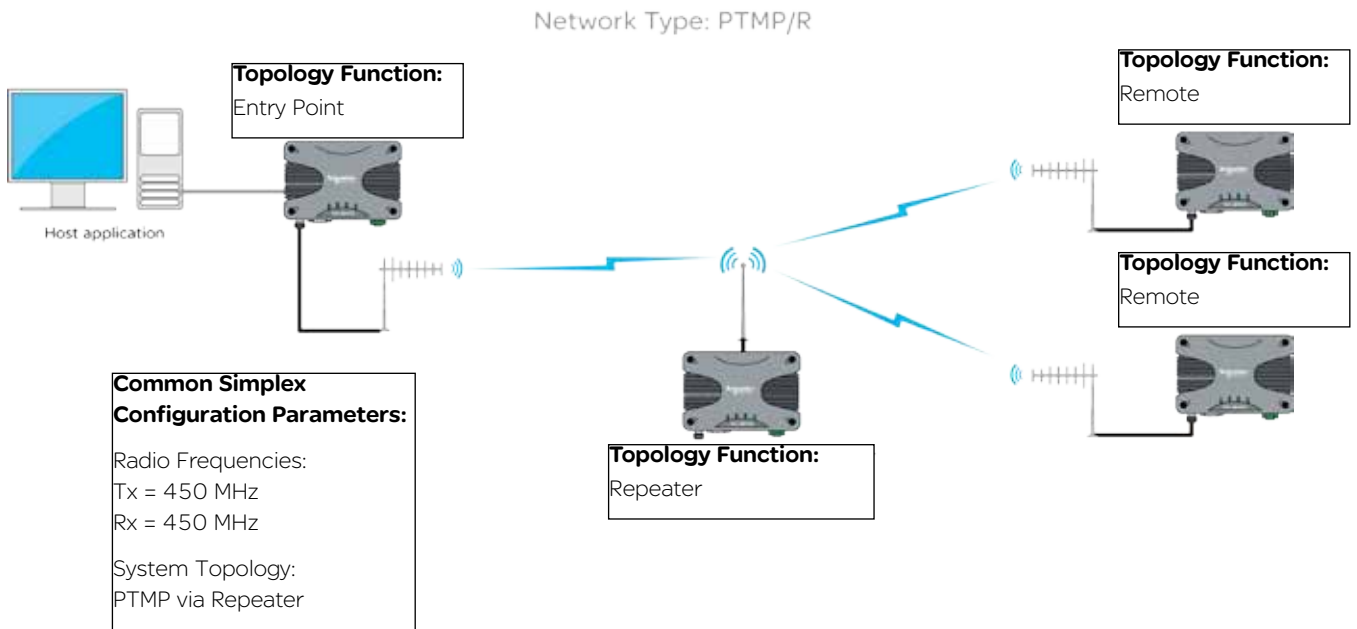

Simplex MPTMP

Multipoint to multipoint in simplex mode can be performed. See the diagram below for an example:

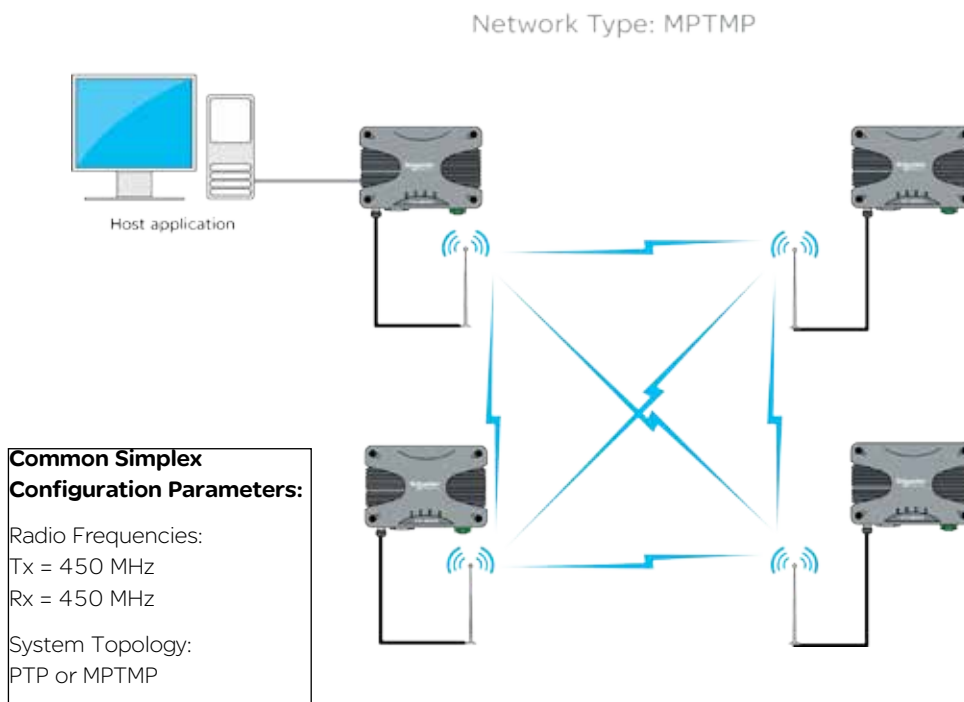

E-Series Emulation Mode

Introduction

As of firmware release 1.3.6.3674, the Q (UHF only) supports E-Series emulation mode. The Diagram below shows a typical E-Series PTMP via Repeater topology, where the remote sites have been replaced with half duplex Q data radios. Configuration values which are fundamental to a successful radio link are shown below to provide an example on how to configure the Q data radios in E-Series emulation mode. Single frequency or two frequency systems can utilise E-Series emulation mode.

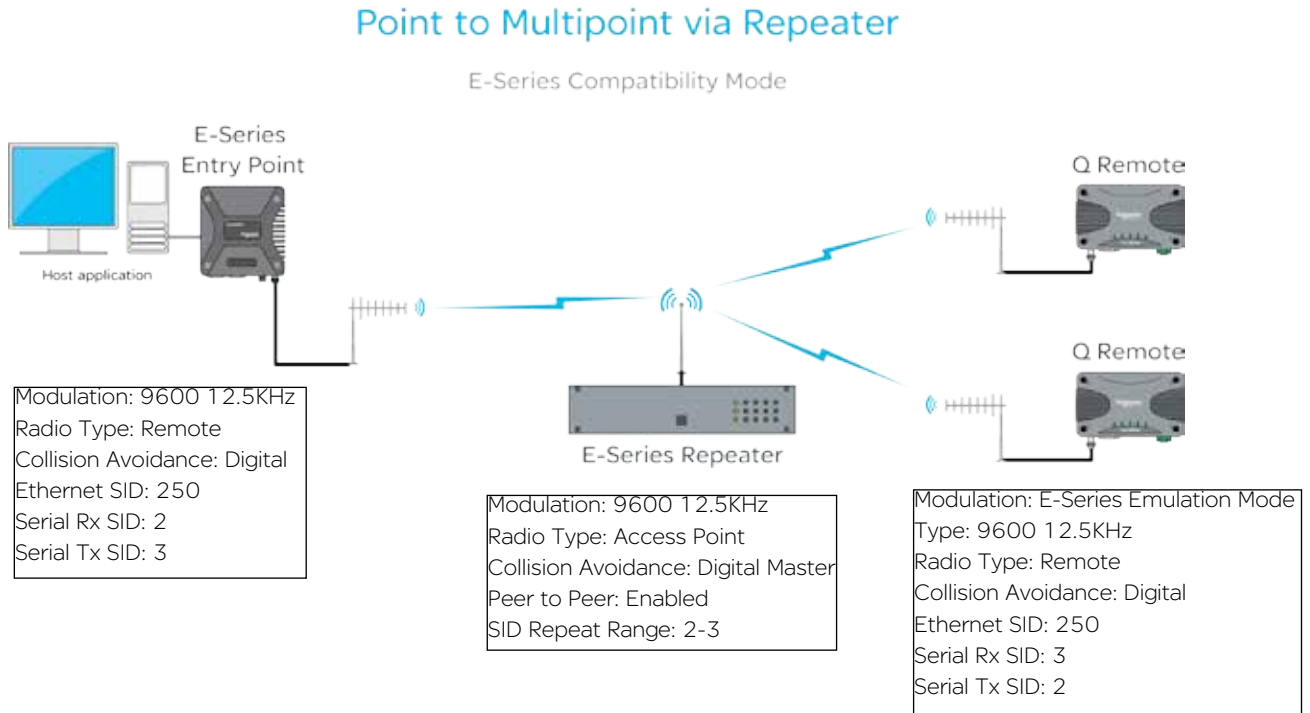

Configuration

The configuration parameters shown in the diagram above can be accessed within the Q data radio within the following locations:

Modulation (Setup -> Radio -> Modulation) provides the compatibility options of: Q Data Radio Mode or E/M Data Radio Mode.

Compatibility

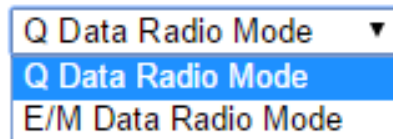

Radio Type (Setup -> Radio -> System Parameters) provides the options of:

- Access Point
- Remote

Radio Type

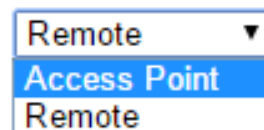

Type (Setup -> Radio -> Modulation) the following bandwidth/data rates are supported. Availability is dependant on the regional approval of the radio (ACMA/ETSI/FCC):

• E-Series

- 9600 12.5 kHz ACA 4 Level
- 19200 25.0 kHz ACA 4 Level
- 9600 12.5 kHz FCC 4 Level
- 19200 12.5 kHz FCC 4 Level
- 19200 25.0 kHz FCC 2 Level
- 9600 12.5 kHz ETSI 4 Level

• M-Series

- 9600 25.0kHz ACA M-Series
- 4800 12.5kHz ACA M-Series
- 4800 25.0kHz ACA M-Series
- 2400 12.5kHz ACA M-Series
- 9600 12.5kHz FCC M-Series
- 4800 12.5kHz ETSI M-Series

For BER specifications and/or sensitivities, refer to the corresponding E or M Series Data sheet.

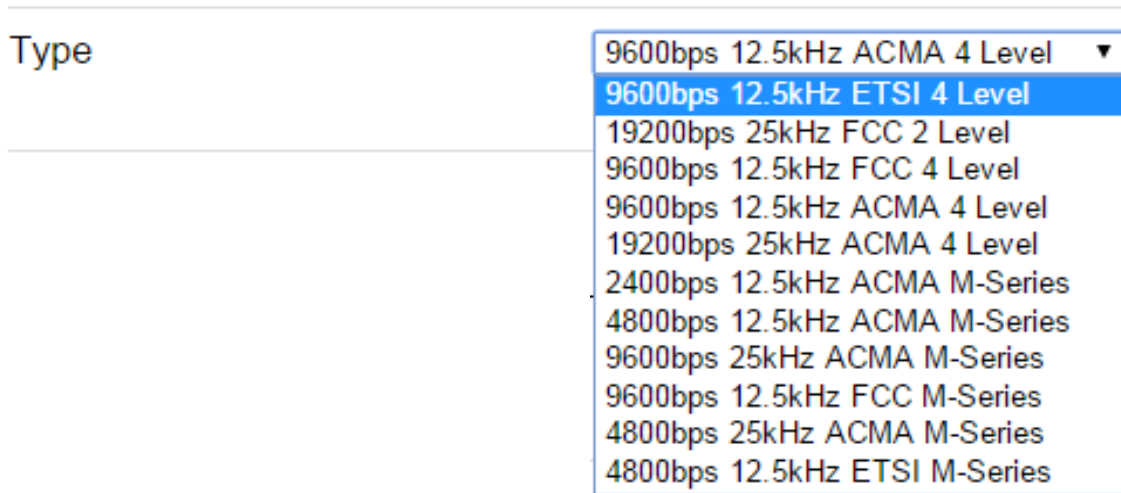

Ethernet Stream ID (SID) (Setup -> Radio -> System Parameters) provides the configuration option of Ethernet SID to be used

Ethernet SID

Serial Rx/Tx SIDs (Setup -> Serial COM 1 (or 2) provides the configuration options of the Serial SIDs to be used

Rx SID

Tx SID

Radio configuration is still performed via WUI or TUI (not via TView+ Programmer).
 For detailed information on E-Series parameters, refer to the E-Series user manual.

Part H – Advanced

Connectivity

Text User Interface (TUI)

The Text user interface can be accessed via; a serial connection, a Telnet session or a SSH session.

TUI Interface - Serial Console

The serial TUI interface is accessed via the COM 1/2 interface as shown in the diagram below. By default, the TUI can be accessed via COM 1 (Pins 2,3 & 5) .

Text User Interface:

- Com 1
- Port Speed : 19200 bps
- Format : 8, N, 1

Connection to the PC requires a strait-through serial cable with Pins 2,3 & 5 connected. Hardware handshaking is not enabled by default within the Q data radios, so unless handshaking is a requirement, no other connections are required.

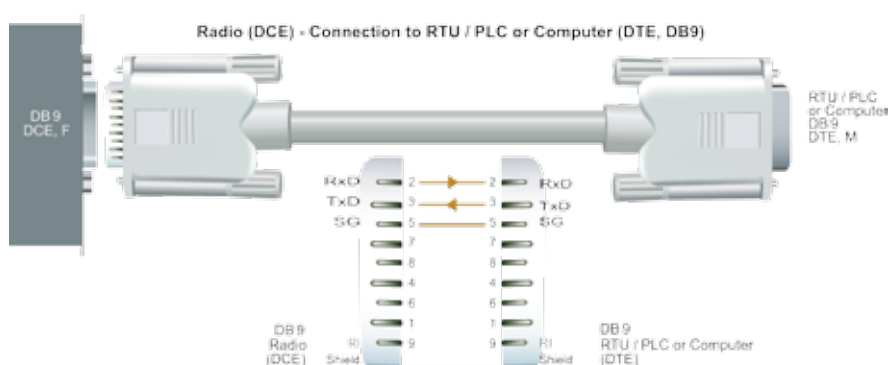

Once the Q data radio is connected to the PC via a strait through serial cable, use a serial console tool to create a serial communications connection to the TUI. The following example uses a software package called 'PuTTY'. PuTTY is a freely available Serial console, SSH and Telnet client. PuTTY can be downloaded from: <http://www.putty.org/>

Once installed, open PuTTY to display the configuration window.



Within the 'Category' section, go to: Connection > Serial. Within the serial line configuration section configure the serial port you will be using to interface to the Q data radio to the following settings:

- Speed (baud): 19200
- Data bits: 8
- Stop bits: 1
- Parity: None
- Flow control: None

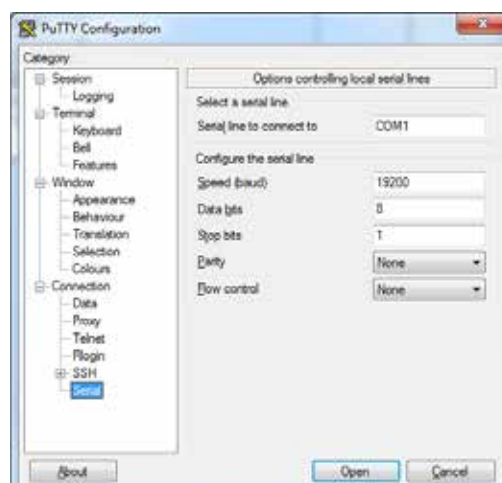

TUI Interface - Telnet session

The text user interface can be accessed via Telnet. This is convenient if you are remotely connected to a Q data radio via an Ethernet network. The Telnet interface requires much less bandwidth compared to the web user interface, which results in higher speed access to configuration parameters and diagnostics. Most computer operating systems come with integrated Telnet software. For Windows based operating system, you can initiate a Telnet session using the command line interface.

Before you can connect to the text user interface (TUI) via Telnet, ensure that the Telnet interface within the Q data radio is enabled. By default, the Telnet service is enabled. The Telnet service can be enabled/disabled using the Web user interface. Enable the interface via the “Configuration -> Security” menu item as shown below.

Telnet Terminal

Enable Disable

Telnet Terminal:

Set to enable Telnet Sessions.

To start a Telnet session, open a command window via “Start -> Run” and type “Telnet xxx.xxx.xxx.xxx” where xxx is the IP address of the target radio. See example below.

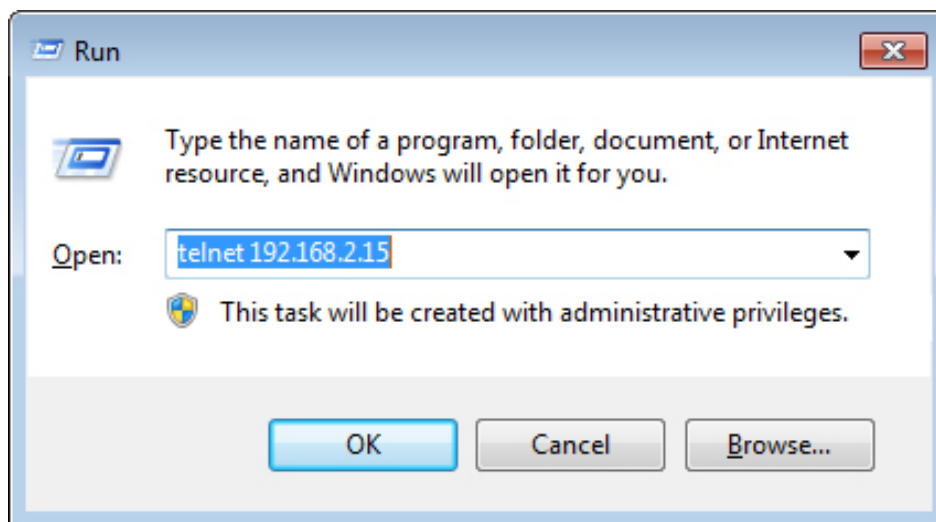

If the Telnet connection was successful, the following screen will be displayed.

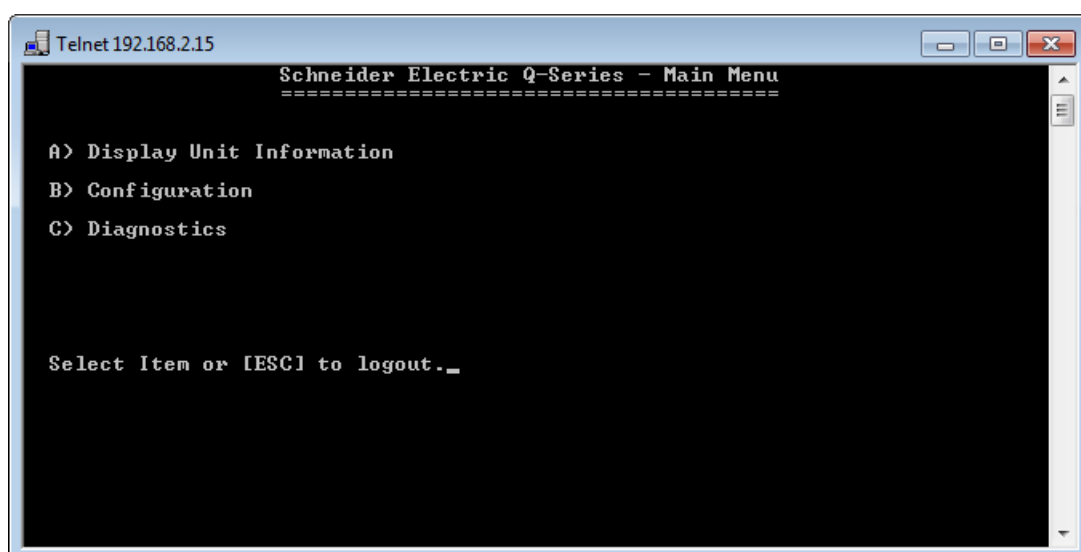

If security password protection has been enabled, you will first need to enter the appropriate user name and password.

The TUI is divided into three distinct areas :

(1) Unit Information - Displays unique unit information about the radio such as serial number, currently configured IP address and firmware pack version identification.

```

Unit Information
=====
Model:                QR450
Reference:            TBURQR4LH-E00E1L0
Serial Number:       700271
Firmware Version:    1.0.0.2665
AES Encryption:      Enabled
Feature License [Serial]: Enabled
Feature License [Ethernet]: Enabled
Regulatory Region:   ETSI/ACMA
Hardware Revision:    E5
IP Address:          192.168.2.15
MAC Address:         00:1F:EB:20:03:2D
  
```

(2) Configuration - Provides access to the configuration of Network Parameters, Radio configuration, Serial interfaces, eDiags, Security, SNMP and IP routing.

```

Configuration Menu
=====
A) Network
B) Radio
C) Serial COM1
D) Serial COM2
E) eDiags
F) Security
G) SNMP
I) IP Routing
J) Activate Configuration
Select Item or [ESC] to go back
  
```

(3) Diagnostics - Provides access to the Diagnostics facilities in the radio.

```

Diagnostics
=====
Unit                               Radio
====                               =====
Date:    Mon Nov 24 20:05:56 1975  Rx Packets:    1
time(s): 9254.61                    Rx Bytes:      17
U Load:  20 percent                  Tx Packets:    1086
pply(U): 12.3                       Tx Bytes:     97501
mp(C):   42.4                       Forward Power (dBm): 30.0
mp(F):   100.14                     Reverse Power (dBm): 30.5
                                         USWR:         > 10.0:1
                                         RSSI (dBm):   10.2
                                         Rx Freq Offset (Hz): 0.0
                                         ARQ Retransmitted Packets: 0
                                         ARQ Discarded Packets: 0
                                         Radio RF Data Rate (bps): 14000

twork
====
H 1 Rx Packets: 0
H 1 Rx Bytes:  0
H 1 Tx Packets: 0
H 1 Tx Bytes:  0
ETH 2 Rx Packets: 1216
ETH 2 Rx Bytes: 99833
ETH 2 Tx Packets: 116
ETH 2 Tx Bytes: 21957

Select [ESC] to go back.
  
```

Secure Shell (SSH)

Secure Shell (SSH) provides a secure alternative to standard Telnet. To access the Q data radio's Text User Interface (TUI) via the embedded SSH server, use an SSH client. The following example shows how to access a Q data radio's TUI using a commonly used Windows SSH client called PuTTY.

Before you can connect to the TUI via SSH, ensure that the SSH server within the Q data radio is enabled (set to SSH Terminal to Enable). For security reasons, the SSH server is disabled by default. It can be enabled via the web user interface. Enable the interface via the "Configuration -> Security" menu item as shown.

Upon enabling SSH, you will also be required to fill out a user name and password. Ensure that you record this user name and password for future use.

In order for the SSH client to know it is communicating with the device it is addressing (not a "man in the middle"), the client will attempt to first authenticate the server.

Administration	
Security	<input checked="" type="radio"/> Enable <input type="radio"/> Disable
Login name	<input type="text" value="admin"/>
Password	<input type="text"/>
Confirm Password	<input type="text"/>
Telnet Terminal	<input checked="" type="radio"/> Enable <input type="radio"/> Disable
SSH Terminal	<input checked="" type="radio"/> Enable <input type="radio"/> Disable

The client will take the following process to authenticate the server:

- The client requests the device finger print from the server it is trying to connect to.
- Once the client has received the server's finger print, it will check it's own records to see whether it already has this finger print in memory.
- If it does have the finger print on record, the connection between the client and the server should automatically begin.
- If the client does not have the finger print in memory, a security alert will appear, advising the user that either an attacker could be intercepting the device as it does not have the finger print on record, or it is a new device that it has not connected to before.



As there is no way of differentiating between a "man in the middle" attack or a first time connection due to the finger print not stored on the client's records, it is advised that the SSH server (Q data radio) is always connected locally to the client and read before they are deployed in the field. This will allow the client to store the server's finger print on record and will help prevent any chances of undetected "man in the middle" attacks.

Once a finger print has been stored into memory, it can be extracted from the registry (Putty example only)

HKEY_CURRENT_USER\Software\SmonTatham\Putty\SSHHostKeys.

This can then be deployed into another client PC if required.

Configure the SSH client (in this case PuTTY) to interface correctly with the embedded Q data radio's SSH server.

The Port number for the embedded Q data radio's SSH terminal is 22. This is a standard and is not user definable.

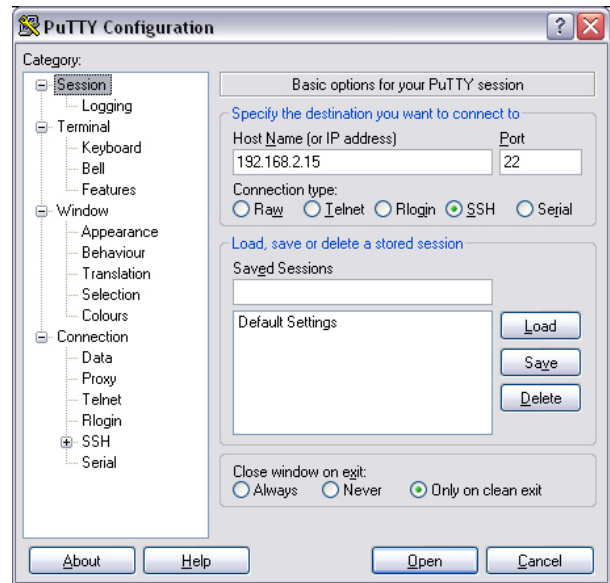

The SSH terminal also requires a user name and password to be configured. Upon logging into the Q data radio via SSH, the user will be prompted for the user name and password.

Once the correct user name and password have been entered, the Q data radio will grant access to the TUI main menu.

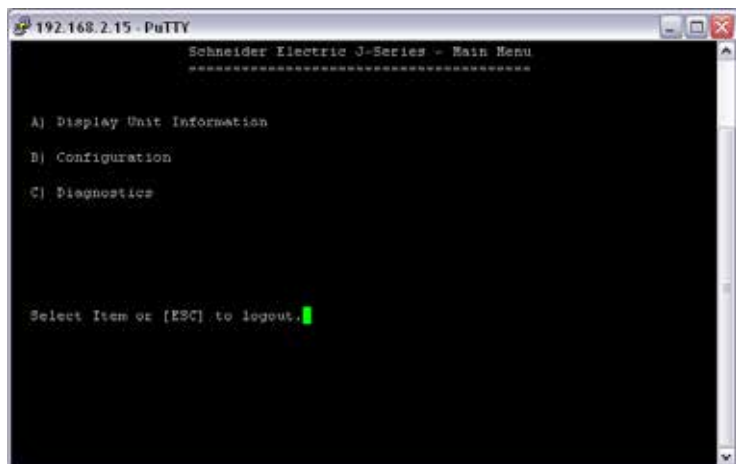

Web User Interface (WUI)

The Web User Interface can be accessed via a HTTP connection or a HTTPS connection. For instructions on how to access the WUI via a HTTP connection, refer to the Quick Reference Guide section within this manual.

HTTP Secure (HTTPS)

The Q data radio's web user interface can be accessed through a secure HTTP (HTTPS) connection.

There are multiple steps required to establish a successful HTTPS connection to a Q data radio, which include:

- Enabling HTTPS within the Q data radio.
- Loading a signed, digital certificate into the Q data radio. This may be generated by a certificate server (i.e. Active directory) or can be self-generated by the Q data radio.
- Resolving web browser issues.

Once the above steps have been completed, enter "HTTPS://xxx.xxx.xxx.xxx" where 'x' is the unit's IP address, into the web browser's URL bar and press enter.

Enabling HTTPS within a Q data radio:

Browse to the unit's Security page (Setup -> Security) and under the Administration heading, you are able to enable/disable HTTPS. You also have the option to disable HTTP access once HTTPS is enabled.

Administration

Security	<input type="radio"/> Enable <input checked="" type="radio"/> Disable	Security: Enable administration security.
Telnet Terminal	<input checked="" type="radio"/> Enable <input type="radio"/> Disable	Telnet Terminal: Set to enable Telnet Sessions.
Https Access	<input checked="" type="radio"/> Enable <input type="radio"/> Disable	Https Access: Enable secure https (https) access.
Http Access	<input checked="" type="radio"/> Enable <input type="radio"/> Disable	Http Access: Enable insecure http access.

Loading a digitally signed certificate into a Q data radio:

Certificate Management Server:

A certificate can be generated and signed from a certificate management server. Once a certificate is signed, it should then be loaded into the Q data radio. An example of commonly used certificate management server is Active directory. For each individual unit, a unique certificate is required. Certificates used are bound to each unit by its IP address and serial number. If the IP address of a unit is changed, the certificate needs to be re-generated and re-loaded back into the Q data radio.

HTTP SSL Certificate

Upload Certificate:

To load a signed certificate into a Q data radio via the WUI, browse to the Security Management page (Maintenance -> Security management) and select the 'Browse' button.

Verify the correct file has been selected, then press the 'Upload' button.

Once the certificate has been successfully uploaded, a message will appear and information about the certificate will be visible within the current certificate section.

Unless the certificate management server has been linked to the web browser as a trusted certificate server, the browser may display security messages upon entry to the Q data radio WUI via HTTPS. To add exceptions into the browser for these security messages see the instructions on the following page.

Self signed certificate:

A self signed certificate can easily be generated from within the Q data radio. To generate a self signed certificate, browse to the security update page (Maintenance -> Security maintenance) and select the 'Generate' button.

Once the self signed certificate has been created, a message will appear and information about the certificate will be visible within the current certification section.

HTTP SSL Certificate

Upload Certificate:

Generate Certificate:

Self-signed certificate generated successfully.

Resolving web browser issues:

Every web browser has a list of trusted Certification Authorities (CAs). When either a CA that is not included within the web browsers trusted list is used to sign a certificate, or a self signed certificate is used, a security message will appear within the web browser when an attempt to access a Q data radio’s WUI via HTTPS is made. See the example below (Example uses internet explorer 8).

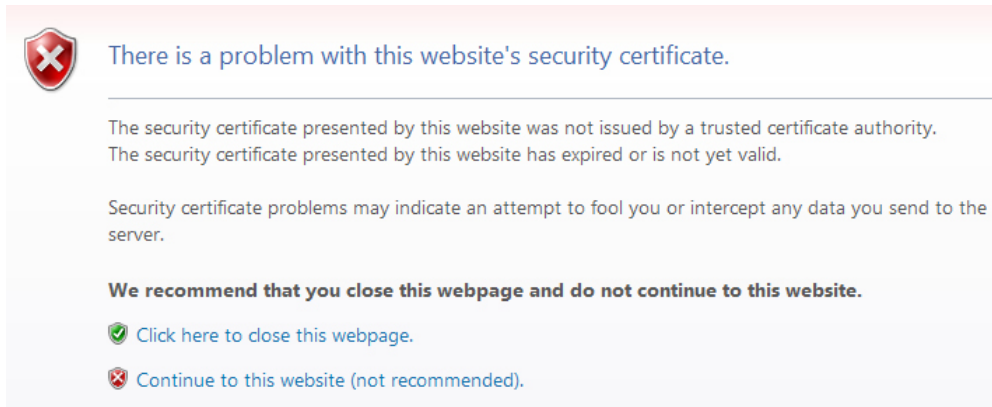

This security message is identifying the fact that the signer of the certificate being read is not within the browser’s trusted list. Pressing the ‘Continue to this website (not recommended)’ button will allow a HTTPS connection through to the Q data radio. The URL bar of the browser will still indicate that the certificate is still not trusted.

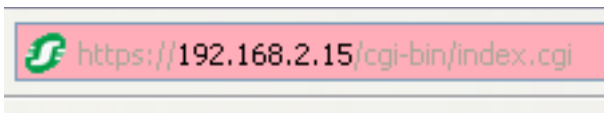

Although the Browser is identifying this, a secure connection should still be in place between the browser and the Q data radio. To add the signer to the browser’s trusted list, follow the steps shown below.

Click on the ‘Certificate Error’ window within the URL bar as shown. This will open a Certificate invalid window, click on the ‘View certificates’ button.

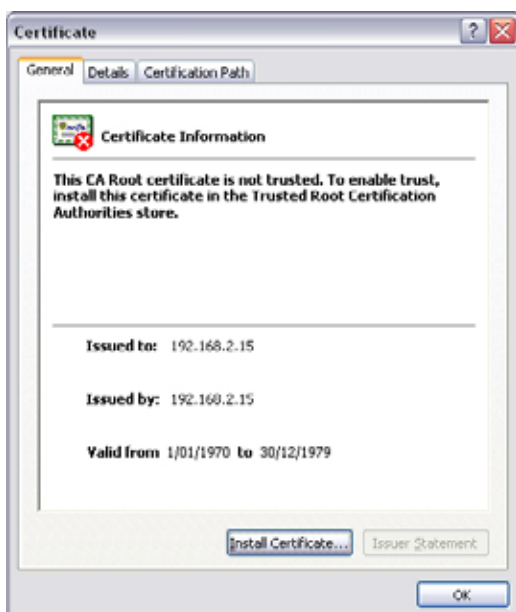
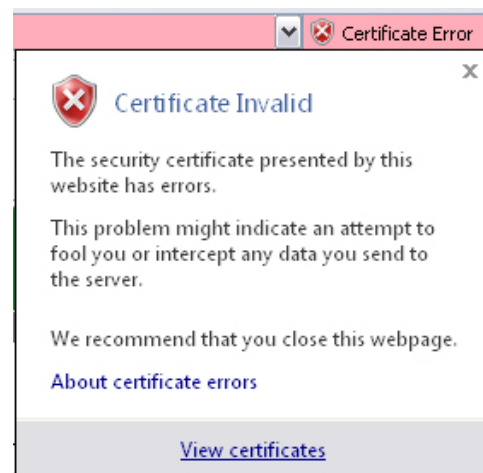

Once the ‘View certificates’ button is selected, a certificate information window will open. Once this window has opened, select the ‘Install Certificate..’ button.

If you cannot see the ‘Install Certificate..’ button, restart Internet explorer in administration mode. Do this by right clicking the Internet Explorer icon on the desktop and selecting ‘open in administrator mode’. If this selection is not available, speak to your system administrator.



This will start the certificate import wizard. Select the Next button.

Select the 'Place all certificates in the following store' option and press the 'Browse...' button.



Select the 'Trusted Root Certification Authorities' folder and press the 'OK' button.



Once the import directory has been selected, press the 'Finish' button.



A security message will appear providing information about the added certificate exception. Press the 'Yes' button to complete the installation process.

















Ease of Use

Alarms

Introduction





The Q data radio can monitor the condition of various diagnostic and operating parameters (i.e DC volts, Tx Power, etc). The radio's active alarms can be evaluated by observing the event history and alarm states.

The alarm states can be viewed within the Monitoring section of the Web User Interface (Monitoring -> Alarms and Events).

ID	ALARM	STATE	CURRENT VALUE
50	Global Alarm		
60	Base Health		
100	Frequency Offset		
110	Received Signal Strength Indication (RSSI)		
120	VSWR		< 1.5:1
130	Tx Power		30.3dBm
140	DC Supply		12.0V
150	Temperature		35.0 (Deg C)
160	Ethernet Link		
170	PLL Lock		
180	Fan		
190	Operational		
200	Rx Packet Comparison		
210	RSSI Comparison		

Alarm States

Depending on active values of monitored alarms, the alarm states can be displayed in different levels of severities, including:

 Disabled  Normal  Recovered  Warning  Critical

- **Disabled:** The alarm is not being monitored.
- **Normal:** The alarm value is in normal (acceptable) operating conditions.
- **Recovered:** The alarm has recovered from a warning or critical state, back into normal operating conditions, the alarm state will remain in a recovered state, until either, the alarms are reset (by clicking the reset alarms button at the top corner of the window) or the alarm state changes again.
- **Warning:** The alarm is within the warning threshold limits defined by the user.
- **Critical:** The alarm is outside of the hardware limits of the radio (alarms which can reach critical severity, can not be disabled).

Configuration

The diagram below provides an example of how an alarm state can be deemed 'Normal' or 'Critical'. The example shows the value thresholds for the normal and critical state of the DC supply in a QB. Once a DC supply measurement is taken, the behavior of the alarm state reporting structure is as follows:

- **Normal:** If the value falls within the green zone (11 to 30 VDC) the alarm state can display 'normal' as this is an acceptable operating value.
- **Critical:** If the value falls within the red zone (below 11 VDC or above 30 VDC) the alarm state can display 'critical' as these values are the hardware limits of the radio (the radio may switch off or self protect depending on the extremity of the critical value).

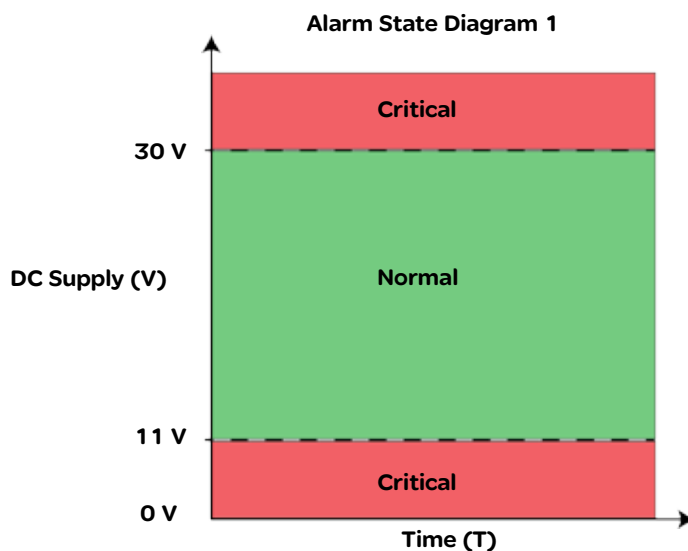

Warning State

Enable/Disable the warning state for the respective alarm being configured. The warning state can help prevent a critical alarm from occurring, by indicating an alarm value has been measured outside of 'normal' operating conditions, but, still within 'critical' operating conditions. This means a warning alarm can be active, before a critical alarm state is reached.

Once the warning alarm is enabled, a limit/threshold should be configured. The diagram below provides an example of how the warning alarm is implemented into the alarm state reporting structure for the DC supply in a QB. Once a DC supply measurement is taken, the behavior of the alarm state reporting structure is as follows:

- **Normal:** If the value falls within the green zone (12 to 28 V) the alarm state can display 'normal' as this is an acceptable operating value.
- **Warning:** If the value falls within the amber zone (11 to 12 V OR 28 to 30V) the alarm state can display 'warning' as this is has been configured by the user to be outside of normal operating conditions.
- **Critical:** If the value falls within the red zone (below 11 V or above 30 V) the alarm state can display 'critical' as these values are the hardware limits of the radio (the radio may switch off or self protect depending on the extremity of the critical value).

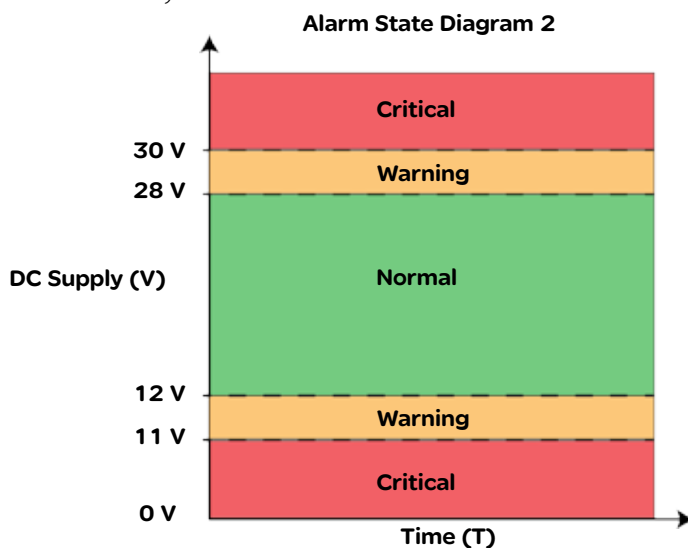

DC Supply	
Warning	<input type="button" value="Enable"/>
Upper	<input type="text" value="28"/>
Lower	<input type="text" value="12"/>
Alarm Output	<input type="radio"/> Enable <input checked="" type="radio"/> Disable

Alarm Specifications

To perform alarm configuration, go to: Setup -> Alarms

Global Alarm	
The global alarm reflects the highest severity state of all the alarm states being monitored. This can allow a user to monitor the global alarm state, and if/when the alarm state changes, a detailed review of the radio's operating condition can be performed.	
Subscriptions available	SNMP Notifications

Operational	
The operational alarm will display a critical state during situations that cannot be resolved by the user through factory default, configuration or firmware upgrade. While an operation alarm is critical, the radio's transmitter may become disabled.	
Subscriptions available	SNMP Notifications, Alarm Output

Temperature	
Units of measurement available	Celsius, Fahrenheit
State Change Hysteresis	1 Deg C (1.8 Deg F)
Subscriptions available	SNMP Notifications, Alarm Output
Critical Alarm	
Upper Critical Alarm Threshold	81 Deg C (177.8 Deg F)
Lower Critical Alarm Threshold	-40 Deg C (-40 Deg F)
Warning Alarm	
Default Upper Warning Alarm Threshold	70 Deg C (113 Deg F)
Default Lower Warning Alarm Threshold	-10 Deg C (14 Deg F)
Configurable Warning Alarm Threshold Range	-40 to 70 Deg C (-40 to 158 Deg F)

Frequency Offset	
Units of measurement available	Hz
State Change Hysteresis	5 Hz
Subscriptions available	SNMP Notifications
Warning Alarm	
Default Upper Warning Alarm Threshold	1000 Hz
Default Lower Warning Alarm Threshold	-1000 Hz
Configurable Warning Alarm Threshold Range	3000 to -3000 Hz

RSSI	
Units of measurement available	dBm
State Change Hysteresis	1 dBm
Subscriptions available	SNMP Notifications
Warning Alarm	
Default Upper Warning Alarm Threshold	-50 dBm
Default Lower Warning Alarm Threshold	-120 dBm
Configurable Warning Alarm Threshold Range	-140 to 0 dBm

VSWR	
Measurement taken	Ratio
Subscriptions available	SNMP Notifications, Alarm Output
Critical Alarm	
Upper Critical Alarm limit	10:1
Warning Alarm	
Default Warning Alarm Limit	3:1
Configurable Warning Alarm Limits	1.5:1, 2:1 or 3:1

DC Supply	
Units of measurement available	DC Volts
State Change Hysteresis	0.5V DC
Subscriptions available	SNMP Notifications, Alarm Output
Critical Alarm	
Upper Critical Alarm Threshold	30V DC
Lower Critical Alarm Threshold	10V DC
Warning Alarm	
Default Upper Warning Alarm Threshold	28V DC
Default Lower Warning Alarm Threshold	12V DC
Configurable Warning Alarm Threshold Range	10 to 30 V DC

Ethernet Link	
The Ethernet link monitor will send pings to a user defined IP address. The radio can raise a warning alarm, if a ping response is not received from the specified IP device.	
Subscriptions available	SNMP Notifications, Alarm Output
Warning Alarm	
Primary IP	The primary IP address to test
Secondary IP	The secondary IP address to test
Fail Threshold	The number of failed pings allowed before an alarm is raised
Retry Interval	The number of seconds to wait before retrying a failed ping

Tx Power	
Units of measurement available	dBm
State Change Hysteresis	2 dBm
Subscriptions available	SNMP Notifications, Alarm Output (QB & QP only)
Critical Alarm	
A Critical alarm will be raised if the radio detects a Tx power level which is +/- 2dBm of the target Tx power.	

PLL Lock	
A critical alarm can be raised if a PLL has been detected out of lock.	
Subscriptions available	SNMP Notifications, Alarm Output

QB and Hot Standby Specific Alarm Specifications

Fan	
A critical alarm can be raised if a fan alarm has been detected.	
Subscriptions available	SNMP Notifications, Alarm Output

Base Health	
The base health alarm is a warning indicator (alarm state can be either normal or warning), which is subscribed to the radio's alarm output. This can allow a user to monitor the base health alarm state, and if/when the alarm state changes, a detailed review of the radio's operating condition can be performed.	
Subscriptions available	SNMP Notifications

The following hot standby specific alarms can only be configured once HSC mode has been enabled within the radio. To enable HSC mode, go to: Setup -> Basestation

Rx Packet Comparison	
A hot standby radio can compare the amount of good packets received by radio A and radio B.	
A warning alarm can be raised if the differential between good packets received by the configured radio and good packets received by the alternate radio is greater than the specified differential. Primarily used in separate antenna arrangements.	
Subscriptions available	SNMP Notifications, Alarm Output
Warning Alarm	
Default Differential Value (%)	20 %

RSSI Comparison	
A hot standby radio can compare the level of RSSI received by radio A and radio B. A warning alarm can be raised if the reported RSSI of the configured radio is lower than the reported RSSI of the alternate radio by the specified margin (dB).	
An offset should be used where the configured radio has an expected reduced RSSI, compared to that of the alternate radio.	
The offset can help detect RSSI compare alarms more accurately within a Hot standby arrangement which utilises separate antennas for each radio.	
The Margin and Offset are configured as a negative number	
Subscriptions available	SNMP Notifications, Alarm Output
Warning Alarm	
Default Margin Value (dB)	-10 dB
Default Offset Value (dB)	0

Alarm Subscription:

Services can be subscribed to alarm state changes for respective alarms. Depending on which service is enabled, a state change can either raise an alarm output, or, send a notification.

The diagram below provides an example of a DC supply dropping and recovering over time.

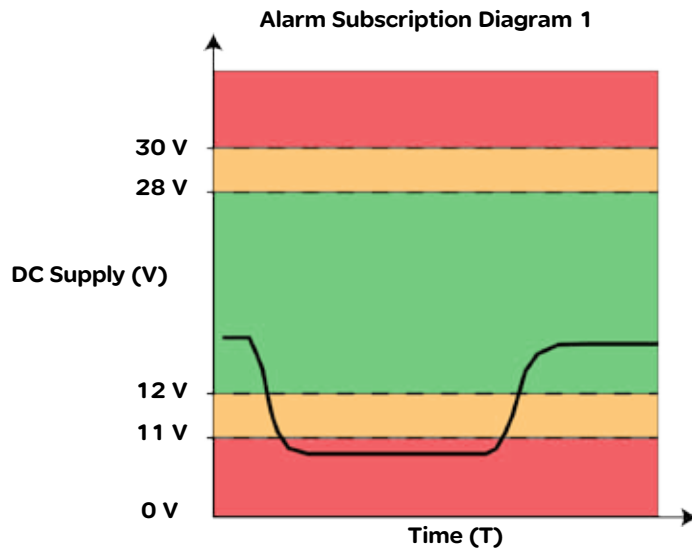

SNMP

The SNMP notifications service can be subscribed to an alarm. This can cause an SNMP notification to be sent to the configured SNMP NMS each time a subscribed alarm changes state. Referring to the example above, an SNMP notification would be sent during each alarm state change.

The SNMP agent and notifications section should be enabled and configured (Setup -> SNMP) before the SNMP notification service can be subscribed to alarms (review the SNMP section for information on the SNMP agent configuration).

To subscribe the SNMP notification service to an alarm, go to Setup -> Alarms, and enable ‘SNMP Notification’ for the respective alarm being subscribed to.

DC Supply

Warning	Enable ▾
Upper	28
Lower	12
SNMP Notification	<input checked="" type="radio"/> Enable <input type="radio"/> Disable
Alarm Output	<input type="radio"/> Enable <input checked="" type="radio"/> Disable

Alarm Output

Available in QB & QP hardware only. The radio alarm output is an internal dual-state indicator (ON/OFF) which can control the dynamic changeover mechanism within a QH (QB with HSC mode enabled) and a QP.

By subscribing the alarm output service to an alarm, the alarm output will turn ON when any subscribed alarm has reached the highest level of alarm severity and will turn OFF when no subscribed alarms are in their highest level of alarm severity.

To subscribe the alarm output service to an alarm, go to Setup -> Alarms, and enable 'Alarm Output' for the respective alarm being subscribed to.

DC Supply

Warning	Enable ▼
Upper	28
Lower	12
Alarm Output	<input checked="" type="radio"/> Enable <input type="radio"/> Disable

Events

Introduction

The Q data radios can log meaningful events that occur throughout the operation of the radio. These events are viewable within the monitoring section (Monitoring -> Alarms and Events).

Each event that is recorded includes the following information:

- **Time Stamp:** The time stamp is only accurate, when the time configuration has been set (Setup -> Network). If the time configuration has not been set, the default starting time for the radio will be used.
- **Event ID:** Each type of event has a unique event identification number. The event IDs and corresponding event descriptions are shown within tables on the following pages.
- **Severity:** There are different event severities depending on the respective event:
 - EVENT: This is an indicative event to record behaviour of the radio (i.e power up, firmware update).
 - NORMAL: This indicates that the recorded event is within acceptable operating conditions
 - WARNING: This indicates that the recorded event is within configured warning conditions
 - CRITICAL: This indicates that the recorded event may cause the radio to stop operating.
- **Notes:** Description of the event which has occurred.

The event log window can be cleared by selecting the 'Clear Logs' button at the top corner of the event log window.

Events				Clear Logs
24/11/1975 17:32:06	400	EVENT	Radio power up.	
24/11/1975 17:32:06	501	EVENT	Radio firmware installation successful	
26/11/1975 20:33:22	500	EVENT	Radio firmware installation activated. 1.2.6.3524 -> 1.2.6.3545	
24/11/1975 17:32:10	300	EVENT	Radio changed to online status.	
24/11/1975 17:32:08	301	EVENT	Radio changed to offline status.	
24/11/1975 17:32:06	400	EVENT	Radio power up.	
24/11/1975 17:32:10	300	EVENT	Radio changed to online status.	
24/11/1975 17:32:08	301	EVENT	Radio changed to offline status.	
24/11/1975 17:32:06	400	EVENT	Radio power up.	
24/11/1975 17:34:29	51	EVENT	Active critical alarms detected.	
24/11/1975 17:34:29	190	CRITICAL	Operational critical alarm detected.	
24/11/1975 17:33:21	300	EVENT	Radio changed to online status.	
24/11/1975 17:33:18	301	EVENT	Radio changed to offline status.	
24/11/1975 17:33:16	400	EVENT	Radio power up.	
24/11/1975 17:33:16	300	EVENT	Radio changed to online status.	

Alarm Events:

Event ID	Description
50	Active warning alarm detected
51	Active critical alarm detected
52	Active critical alarm cleared
53	Active warning alarm cleared
60	Base health alarm detected
61	Base health alarm cleared
100	Frequency offset warning detected
101	Frequency offset warning alarm cleared
110	Received signal level (RSSI) warning alarm detected
111	Received signal level (RSSI) warning alarm cleared
120	High VSWR warning alarm detected
121	High VSWR critical alarm detected
122	High VSWR critical alarm cleared
123	High VSWR warning alarm cleared
130	Transmit power target critical alarm detected
131	Transmit power target critical alarm cleared
140	DC supply warning alarm detected
141	DC supply critical alarm detected
142	DC supply critical alarm cleared
143	DC supply warning alarm cleared
150	Radio Temperature warning alarm detected
151	Radio Temperature critical alarm detected
152	Radio Temperature critical alarm cleared
153	Radio Temperature warning alarm cleared
160	Ethernet link warning alarm detected
161	Ethernet link warning alarm detected cleared
170	PLL Lock critical alarm detected
171	PLL Lock critical alarm cleared
180	FAN critical alarm detected
181	FAN critical alarm cleared
190	Operational critical alarm detected
191	Operational critical alarm cleared
330	Received good data warning alarm detected
331	Received good data warning alarm cleared
340	Good RSSI comparison warning alarm detected
341	Good RSSI comparison warning alarm cleared

Hot Standby Specific Events:

Event ID	Description
300	Radio changed to online status
301	Radio changed to offline status
310	Radio forced to offline
311	Radio forced to online
320	Radio period change-over timer expired.

Operational Events:

Event ID	Description
400	Radio power up
401	User initiated radio reset
402	Watch dog initiated radio reset
403	NTP date/time locked
404	PTT timeout timer activated

Management Events:

Event ID	Description
500	Radio firmware installation activated
501	Radio firmware installation successful
502	Radio firmware installation unsuccessful
510	Factory default reset activated
511	Factory default reset successful
512	Factory default reset unsuccessful
520	Radio configuration change activated
521	Radio configuration change successful
522	Radio configuration change unsuccessful

Base Station

Introduction

Base station hardware (QP and QB) have specific configuration parameters for hardware specific features. To access these configuration parameters go to: Setup -> Basestation.

HSC (Hot Standby Controller) Mode

Only configurable within a QB (a QP always has this enabled), this should be enabled when a QB is operating within a hot standby arrangement.

HSC Mode

Enable ▼

Shared IP Address

Radio A and Radio B within a hot standby arrangement can be configured to 'share' an IP address. This is a separate IP address from each radio's unique IP address. The shared IP address can be used to access the current 'online' radio.

The shared IP address should be configured in radio A & B as the same IP address.

The shared IP address is only available once HSC mode is enabled (a QP always has HSC mode enabled).

Shared IP Mode

Enable Disable

Shared IP

192.168.2.50

General Purpose Digital I/O (GPIO)

The digital outputs can be configured to reflect the status of different operating conditions. By disabling either of the following parameters, the respective digital output can be set manually by the user (TView Diagnostics or SNMP can be used to set the digital output).

Output 1 Alternate Function - When enabled, digital output 1 will subscribe to the base health status (the base health alarm can reflect the status of the alarm output. See the alarms section for further detail). If the output is active, the base health alarm is in warning state.

Output 1 Alternate Function

Enable Disable

Output 2 Alternate Function - When enabled, digital output 2 will reflect which radio of a hot standby arrangement is online.

When the output is inactive: Base A is online

When the output is active: Base B is online

Output 2 Alternate Function

Enable Disable

SNMP Notifications

Configure the radio to send SNMP notifications when a respective event occurs.

GPIO Inputs - By enabling SNMP notification on a GPIO input, the radio will send an SNMP notification to the NMS specified in the configured SNMP section (to access SNMP, go to: Setup -> SNMP), when the respective digital input state changes.

GPIO Input 1 Enable Disable

GPIO Input 2 Enable Disable

GPIO Input 3 Enable Disable

Base Station Health - By enabling the Base Station Health SNMP notification, the radio will send an SNMP notification to the NMS specified in the configured SNMP section (to access SNMP, go to: Setup -> SNMP), when a change in alarm state for the base health alarm occurs.

Base Station Health Enable Disable

Base change over - By enabling the Base change over SNMP notification, the radio will send an SNMP notification to the NMS specified in the configured SNMP section (to access SNMP, go to: Setup -> SNMP), when a hot standby base change over occurs.

Base change over Enable Disable

Advanced

Periodic Switch Over Period - The period, in hours, after which the online base station will initiate an automatic switch over. This can be useful, to exercise each radio within a hot standby arrangement, to validate redundant link availability.

Setting a value of zero will disable this feature.

Periodic Switch Over Period

Hot Standby Status

Introduction

The active condition of a hot standby can easily be reviewed via the hot standby status window. To access this window, go to: Monitoring -> Hot Standby Status.

Alarms for a particular radio can be reset, by clicking the Reset button at the bottom of the respective radios alarms column.

Hot Standby Status

Serial Number	790035	
Selection Mode	Site Forced	
Pending Switchover	<input type="checkbox"/>	
Status	A	B
Online	<input checked="" type="checkbox"/>	<input type="checkbox"/>
Health	<input checked="" type="checkbox"/>	<input type="checkbox"/>
Alarms	A	B
DC Supply	<input checked="" type="checkbox"/>	<input checked="" type="checkbox"/>
Tx Power ¹	<input type="checkbox"/>	<input type="checkbox"/>
Ethernet Link	<input type="checkbox"/>	<input type="checkbox"/>
Temperature	<input checked="" type="checkbox"/>	<input checked="" type="checkbox"/>
PLL lock ¹	<input checked="" type="checkbox"/>	<input checked="" type="checkbox"/>
Operational ¹	<input checked="" type="checkbox"/>	<input checked="" type="checkbox"/>
VSWR	<input checked="" type="checkbox"/>	<input checked="" type="checkbox"/>
Fan	<input checked="" type="checkbox"/>	<input checked="" type="checkbox"/>
RSSI Comparison ²	<input checked="" type="checkbox"/>	<input type="checkbox"/>
Rx Packet Comparison ²	<input checked="" type="checkbox"/>	<input type="checkbox"/>
	<input type="button" value="Reset"/>	<input type="button" value="Reset"/>

Not enabled
 Normal
 Recovered
 Active

Latched Alarms

Once some alarms within a radio have been detected in a their most severe state, the hot standby will no longer dynamically switch over to that radio, to help prevent switching over to a non-functional radio. These type of alarms are called 'Latching Alarms'.

Latching alarms may be reported in a recovered state, but will prevent the hot standby from dynamically changing over to the respective radio, until the alarms have been manually reset.

The list of latching alarms include:

- Tx Power
- PLL Lock
- Operational

A Manual changeover on the front panel switch, or remotely forces change-over, can over-ride, but not clear, a latched alarm.

SNMP - Diagnostic objects and Notifications

Introduction

The Q data radio's SNMP Interface supports:

- Supports RFC1 21 3 (Unit name, Unit Location, Firmware, Uptime, etc). Details about RFC1 21 3 and the SNMP parameters included in this standard can be found in this link : <http://www.ietf.org/rfc/rfc1 21 3.txt>
- Supports Radio and Ethernet Diagnostics (as seen in the HTML Diagnostics overview)
- SNMP V1 & V2c
- SNMP notifications which include traps and informs

MIB Files

Distributed with the Q data radio firmware are two MIB files which provide structure definitions for the SNMP objects. The MIB files are suitable for importation into most common SNMP browsers. Definitions for each SNMP object are noted as comments in the MIB files. Only a summary of each object is noted in this user manual.

SNMP user alarm detection

The Trio Q data radio range can detect a number of SNMP alarms which have been raised due to varying radio diagnostic values. These diagnostic values include:

- VSWR
- Supply Voltage
- Temperature
- RSSI
- Transmit Power

Each SNMP alarm for the diagnostic values shown above, has a maximum of three alarm states. Each one is also represented with a status number. The alarm states and corresponding numbers are as follows:

- **Normal state - 1:** The 'Normal' state will be displayed within an alarm when a diagnostics parameter is operating within normal limits.
- **User alarm state - 2:** A 'User alarm' state will be displayed when a diagnostics parameter within the Q data radio falls outside of the user defined alarm limits. User limits are configurable within the Q data radio.
- **Critical alarm state- 3:** A 'Critical alarm' state will be displayed when a diagnostics parameter within the Q data radio falls outside of the unit's hardware specification.

SNMP critical alarm detection

The Trio Q data radio range can detect a number of SNMP alarms which have been raised due to the operational state of the radio. These operational states include:

- Transmitter PLL locked
- Receiver PLL locked
- Operational alarm detected
- Fan alarm detected (QB, QP & QH only)

Each SNMP alarm for the operational states shown above, has a maximum of two alarm states. Each one is also represented with a status number. The alarm states and corresponding numbers are as follows:

- **Yes state - 1:** The 'Yes' state will be displayed if the corresponding operational state is active/true.
- **No state - 2:** The 'No' state will be displayed if the corresponding operational state is inactive/false.

Notifications

SNMP notifications are unsolicited SNMP messages designed to inform a user when an SNMP alarm state change has been detected. The Q data radio range supports two types of notifications:

- **Traps:** are low bandwidth consuming UDP notifications that have no requirement for a response. If the message is lost along the way to the destination IP address, the message will be lost.
- **Informs:** are essentially traps, that require a response from the destination IP address once a notification has been sent. This gives informs more reliability getting to a destination as the Q data radio range supports retries and time out periods.

Summary of SNMP MIB Objects Supported

Object name	Object Identifier (OID)	Syntax	Object description
General Group:			
serialNumber	.1.3.6.1.4.1.33302.30.1.1.0	String	Serial number of the Q data radio
modelName	.1.3.6.1.4.1.33302.30.1.2.0	String	Model number of the Q data radio
hardwareRevision	.1.3.6.1.4.1.33302.30.1.3.0	String	Hardware revision of the Q data radio
firmwareRevision	.1.3.6.1.4.1.33302.30.1.5.0	String	The firmware revision the Q data radio
date	.1.3.6.1.4.1.33302.30.1.6.0	String	The date as reported by the Q data radio
time	.1.3.6.1.4.1.33302.30.1.7.0	String	The time as reported by the Q data radio
utcTimeOffset	.1.3.6.1.4.1.33302.30.1.8.0	String	Time offset from UTC for the Q data radio's local time zone
upTime	.1.3.6.1.4.1.33302.30.1.9.0	String	The uptime of the Q data radio
primaryNtpServer	.1.3.6.1.4.1.33302.30.1.10.0	String	Primary Network Time Protocol (NTP) domain name
cpuLoad	.1.3.6.1.4.1.33302.30.1.11.0	Integer	Average CPU utilisation (%) for the past 15 minutes
supplyVoltage	.1.3.6.1.4.1.33302.30.1.12.0	Integer	Supply Voltage of the Q data radio in mV
TemperatureTable	.1.3.6.1.4.1.33302.30.1.13.0	Table	Table of radio temperatures.
ipAddress	.1.3.6.1.4.1.33302.30.1.15.0	IP Address	The IP address of the Q data radio.
Radio Group:			
radioReceivedPackets	.1.3.6.1.4.1.33302.30.2.3.0	Counter	Number of packets received from over the radio link
radioTrasnmittedPackets	.1.3.6.1.4.1.33302.30.2.4.0	Counter	Number of packets transmitted over the radio link
radioForwardPowerTable	.1.3.6.1.4.1.33302.30.2.5.0	Table	Table of radio forward powers.
radioReversePowerTable	.1.3.6.1.4.1.33302.30.2.6.0	Table	Table of radio Reverse powers.
radioVswrTable	.1.3.6.1.4.1.33302.30.2.7.0	Table	Table of radio VSWR's
radioRssiTable	.1.3.6.1.4.1.33302.30.2.8.0	Table	Table of RSSI values.
radioDataRate	.1.3.6.1.4.1.33302.30.2.15.0	Integer	The over-the-air data rate of the Q data radio. [Dynamic(0), 8000bps(1), 14000bps(2), 16000bps(3), 24000bps(4), 28000bps(5), 32000bps(6), 42000bps(7), 56000bps(8), 9600bps(9), 19200bps(10), 2400bps(11), 4800bps(12)]
txFrequency	.1.3.6.1.4.1.33302.30.2.18.0	Integer	Radio's transmit frequency (Hz).
rxFrequency	.1.3.6.1.4.1.33302.30.2.19.0	Integer	Radio's receive frequency (Hz).
muteThreshold	.1.3.6.1.4.1.33302.30.2.20.0	Integer	Radio's mute threshold (dBm).
rxGoodFrameCount	.1.3.6.1.4.1.33302.30.2.23.0	Counter	Good frames received.
rxGoodByteCount	.1.3.6.1.4.1.33302.30.2.24.0	Counter	Good bytes received.
rxBadFrameCount	.1.3.6.1.4.1.33302.30.2.25.0	Counter	Bad frames received.
rxAverageGoodFrameSize	.1.3.6.1.4.1.33302.30.2.26.0	Integer	Average received good frame size.
rxAverageFrameRate	.1.3.6.1.4.1.33302.30.2.27.0	Integer	Average receive frame rate.
rxChannelOccupancy	.1.3.6.1.4.1.33302.30.2.28.0	Integer	Receive channel occupancy.
rxSlidingChannelOccupancy	.1.3.6.1.4.1.33302.30.2.29.0	Integer	Sliding channel occupancy.
txByteCount	.1.3.6.1.4.1.33302.30.2.31.0	Counter	Transmitted byte counter.
txFrameCount	.1.3.6.1.4.1.33302.30.2.32.0	Counter	Transmit frame count.
txAverageFrameSize	.1.3.6.1.4.1.33302.30.2.33.0	Integer	Transmit average frame size.
txAverageFrameRate	.1.3.6.1.4.1.33302.30.2.34.0	Integer	Transmit average frame rate.
radioFrequencyError	.1.3.6.1.4.1.33302.30.2.36.0	Integer	Radio frequency error (Hz).

Object name	Object Identifier (OID)	Syntax	Object description
Security Group:			
snmpVersion	.1.3.6.1.4.1.33302.30.3.1.0	Integer	Default SNMP version
consoleLoginStatus1	.1.3.6.1.4.1.33302.30.3.2.0	Integer	Console login status for COM1
consoleLoginStatus2	.1.3.6.1.4.1.33302.30.3.3.0	Integer	Console login status for COM2
numberOfActiveTelnetSessions	.1.3.6.1.4.1.33302.30.3.4.0	Integer	Number of active Telnet sessions
TelnetSessionTable	.1.3.6.1.4.1.33302.30.3.5.0	Table	Table of Telnet and Ssh sessions
encryptionStatus	.1.3.6.1.4.1.33302.30.3.11.0	Integer	Encryption status
ETH Group:			
ethInterfaceTable	.1.3.6.1.4.1.33302.30.4.1.0	Table	Table of network interfaces
interfaceName	.1.3.6.1.4.1.33302.30.4.1.1.2.x	String	Ethernet interface (row) name (where x is the Ethernet interface - 1 [ETH1], 2 [ETH2] or 3[(ETH3])
interfaceStatus	.1.3.6.1.4.1.33302.30.4.1.1.3.x	Integer	Ethernet interface (row) name (where x is the Ethernet interface - 1 [ETH1], 2 [ETH2] or 3[(ETH3])
interfaceSpeed	.1.3.6.1.4.1.33302.30.4.1.1.4.x	Integer	Ethernet interface (row) name (where x is the Ethernet interface - 1 [ETH1], 2 [ETH2] or 3[(ETH3])
interfaceMode	.1.3.6.1.4.1.33302.30.4.1.1.5.x	Integer	Ethernet interface (row) name (where x is the Ethernet interface - 1 [ETH1], 2 [ETH2] or 3[(ETH3])

Alarm Group:			
operationalAlarm	.1.3.6.1.4.1.33302.30.5.1.0	Integer	Operational alarm
rxPllLocked	.1.3.6.1.4.1.33302.30.5.2.0	Integer	Receiver PLL lock status
radioVswrAlarmTable	.1.3.6.1.4.1.33302.30.5.10.0	Table	Table of VSWR alarms
radioVswrAlarmState	.1.3.6.1.4.1.33302.30.5.10.1.2.1	Integer	High VSWR Normal =Operating within normal conditions, UserAlarm =Operating outside of user specified limits, CriticalAlarm =Operating outside of specified operating limits. Recovered =Normal operating conditions restored.
externalSupplyVoltageAlarmState	.1.3.6.1.4.1.33302.30.5.11.0	Integer	External supply voltage Normal =Operating within normal conditions, UserAlarm =Operating outside of user specified limits, CriticalAlarm =Operating outside of factory specified operating limits. Recovered =Normal operating conditions restored.
temperatureAlarmState	.1.3.6.1.4.1.33302.30.5.12.0	Integer	Internal temperature. Normal =Operating within normal conditions, UserAlarm =Operating outside of user specified limits, CriticalAlarm =Operating outside of specified operating limits. Recovered =Normal operating conditions restored.
radioRssiAlarmTable	.1.3.6.1.4.1.33302.30.5.13.0	Table	Table of radio RSSI alarm states
radioRssiAlarmState	.1.3.6.1.4.1.33302.30.5.13.1.2.1	Integer	RSSI Normal =Operating within normal conditions, UserAlarm =Operating outside of user specified limits. Recovered =Normal operating conditions restored.

Alarm Group (Continued):			
radioTxPowerAlarmTable	.1.3.6.1.4.1.33302.30.5.14.0	Table	Table of radio tx power alarms.
radioTxPowerAlarmState	.1.3.6.1.4.1.33302.30.5.14.1.2.1	Integer	Tx Power Normal =Operating within normal conditions, CriticalAlarm =Operating outside of specified operating limits. Recovered =Normal operating conditions restored.
globalAlarmState	.1.3.6.1.4.1.33302.30.5.15.0	Integer	Global Monitored Alarm. Normal =All monitored parameters are operating within normal conditions, UserAlarm =One or more monitored parameters are operating outside of user specified limits, CriticalAlarm =One or more monitored parameters are operating outside of factory specified operating limits. Recovered =One or more monitored parameters had its normal operating conditions restored.
txPllLocked	.1.3.6.1.4.1.33302.30.5.17.0	Integer	Transmit PLL lock status
radioFrequencyOffsetAlarmState	.1.3.6.1.4.1.33302.30.5.18.0	Integer	Frequency error state. Normal =Operating within normal conditions, UserAlarm =Receive frequency error out of user specified limits. Recovered =Normal operating conditions restored.
radioPllLockedAlarmState	.1.3.6.1.4.1.33302.30.5.19.0	Integer	Normal =Operating within normal conditions, CriticalAlarm =Tx/Rx PLL failed to lock, Recovered =Normal operating conditions restored.
radioRssiCompareAlarmState	.1.3.6.1.4.1.33302.30.5.20.0	Integer	Normal =Operating within normal conditions, UserAlarm =Rssi compared with paired unit dropped below user specified limits, Recovered =Normal operating conditions restored.
radioGoodRxPacketAlarmState	.1.3.6.1.4.1.33302.30.5.21.0	Integer	Normal =Operating within normal conditions, UserAlarm =Rx packet compared with paired unit dropped below user specified limits, Recovered =Normal operating conditions restored.
ethernetLinkAlarmState	.1.3.6.1.4.1.33302.30.5.22.0	Integer	Normal =Operating within normal conditions, UserAlarm =Ethernet link target unreachable, Recovered =Normal operating conditions restored.
resetAlarms	.1.3.6.1.4.1.33302.30.5.100.0	Integer	Read/Write Parameter Reset alarms on current module.

SNMP - Critical Alarm Object Specifications

Operational Alarm Detection	
Name	operationalAlarm
Alarm states	Yes (1), No (2)
Alarm limits	No limits, if the radio go into a operational alarm state, the object changes alarm state to Yes (1). During normal operation, this alarm state in No (2)

Receiver PLL Lock Alarm Detection	
Name	rxPllLocked
Alarm states	Yes (1), No (2)
Alarm limits	No limits, if the radio detects the receiver PLL is no longer in lock, the object changes alarm state to No (2). During normal operation, this alarm state in Yes (1)

Transmitter PLL Lock Alarm Detection	
Name	txPllLocked
Alarm states	Yes (1), No (2)
Alarm limits	No limits, if the radio detects the transmitter PLL is no longer in lock, the object changes alarm state to No (2). During normal operation, this alarm state in Yes (1)

SNMP - Notifications

Customisations can be made on which SNMP alarms will be detected, along with the user alarm limits which will trigger an alarm state change and can be sent as a notification.

To configure which alarms are to be detected or to configure the limits of a user alarm state change, see the user alarm management section found within the SNMP page of the Q data radio web user interface. Specifications on alarms which can be sent as notifications, can be found within the tables below:

Global Alarm Detection Notification

The global alarm detection notification can be sent when the global alarm state is changed. The global alarm state will change based on the highest active alarm state (1 Normal state, 2 User alarm state, 3 Critical alarm state) of all of the alarm objects shown in the table below. When a global alarm detection notification is sent, the notification will include all of the alarm objects and their alarm states, shown in the table below.

Global Alarm Detection Notification				
Notification Name	notificationGloalAlarmChanged			
Notification OID	.1.3.6.1.4.1.33302.30.10.12			
Global Alarm Detection Notification Objects				
Name	OID	Position	Specific Code	Description
globalAlarmState	.1.3.6.1.4.1.33302.30.5.15.0	0	12	Global alarm state
externalSupplyVoltageAlarmState	.1.3.6.1.4.1.33302.30.5.11.0	1	12	Supply voltage alarm state
temperatureAlarmState	.1.3.6.1.4.1.33302.30.5.12.0	2	12	Temperature alarm state
rxPllLocked	.1.3.6.1.4.1.33302.30.5.2.0	3	12	Receiver PLL lock alarm state
txPllLocked	.1.3.6.1.4.1.33302.30.5.17.0	4	12	Transmit PLL lock alarm state
radioFrequencyErrorState	.1.3.6.1.4.1.33302.30.5.18.0	5	12	Radio frequency error alarm state
radioTxPowerAlarmState	.1.3.6.1.4.1.33302.30.5.14.1.2.1	6	12	Radio Tx power alarm state
radioVswrAlarmState	.1.3.6.1.4.1.33302.30.5.10.1.2.1	7	12	VSWR alarm state
radioRssiAlarmState	.1.3.6.1.4.1.33302.30.5.13.1.2.1	8	12	Radio RSSI alarm state

Diagnostics Heartbeat Notification

The diagnostics heartbeat notification does not rely on a change of state in order to send a notification. Instead, the diagnostics heartbeat will send a notification periodically, based on a time period, specified by the user. In each notification sent, the values for each of the embedded objects (shown in the table below) will be sent.

Diagnostics Heartbeat Notification				
Notification Name	notificationDiagnostic			
Notification OID	.1.3.6.1.4.1.33302.30.10.13			
Diagnostics Heartbeat Notification Objects				
Name	OID	Position	Specific Code	Description
sysName	.1.3.6.1.2.1.1.5.0	0	13	System name
sysLocation	.1.3.6.1.2.1.1.6.0	1	13	System location
serialNumber	.1.3.6.1.4.1.33302.30.1.1.0	2	13	Radio serial number
modelName	.1.3.6.1.4.1.33302.30.1.2.0	3	13	Radio model number
supplyVoltage	.1.3.6.1.4.1.33302.30.1.12.0	4	13	Supply voltage value
sysUpTime	.1.3.6.1.2.1.1.3.0	5	13	System up time
globalAlarmState	.1.3.6.1.4.1.33302.30.5.15.0	6	13	Global alarm state
radioFrequencyError	.1.3.6.1.4.1.33302.30.2.36.0	7	13	Radio frequency error
temperatureC	.1.3.6.1.4.1.33302.30.1.13.1.3.1	8	13	Temperature value (Celsius)
temperatureF	.1.3.6.1.4.1.33302.30.1.13.1.4.1	9	13	Temperature value (Fahrenheit)
radioRssiValue	.1.3.6.1.4.1.33302.30.2.8.1.2.1	10	13	radio RSSI value
radioForwardPower	.1.3.6.1.4.1.33302.30.2.5.1.2.1	11	13	Radio Tx power value
radioVswr	.1.3.6.1.4.1.33302.30.2.7.1.2.1	12	13	VSWR value

Operational Alarm Detection Notification				
Notification Name	notificationOperationalAlarm			
Notification OID	.1.3.6.1.4.1.33302.30.10.1			
Operational Alarm Detection Notification Objects				
Name	OID	Position	Specific Code	Description
operationalAlarm	.1.3.6.1.4.1.33302.30.5.1.0	0	1	Operational alarm state

PLL Lock Alarm Detection Notification				
Notification Name	notificationPllLock			
Notification OID	.1.3.6.1.4.1.33302.30.10.2			
PLL Lock Notification Objects				
Name	OID	Position	Specific Code	Description
rxPllLocked	.1.3.6.1.4.1.33302.30.5.2.0	0	2	Receiver PLL lock alarm state
txPllLocked	.1.3.6.1.4.1.33302.30.5.17.0	1	2	Transmit PLL lock alarm state

VSWR Alarm Detection Notification				
Notification Name	notificationVswr			
Notification OID	.1.3.6.1.4.1.33302.30.10.4			
VSWR Notification Objects				
Name	OID	Position	Specific Code	Description
radioVswrAlarmState	.1.3.6.1.4.1.33302.30.5.10.1.2.1	0	4	VSWR alarm state
radioVswr	.1.3.6.1.4.1.33302.30.2.7.1.2.1	1	4	VSWR value

Temperature Alarm Detection Notification				
Notification Name	notificationTemperature			
Notification OID	.1.3.6.1.4.1.33302.30.10.5			
Temperature Notification Objects				
Name	OID	Position	Specific Code	Description
temperatureAlarmState	.1.3.6.1.4.1.33302.30.5.12.0	0	5	Temperature alarm state
temperatureC	.1.3.6.1.4.1.33302.30.1.13.1.3.1	1	5	Temperature value (Celsius)
temperatureF	.1.3.6.1.4.1.33302.30.1.13.1.4.1	2	5	Temperature value (Fahrenheit)

Supply Voltage Alarm Detection Notification				
Notification Name	notificationSupplyVoltage			
Notification OID	.1.3.6.1.4.1.33302.30.10.6			
Supply Voltage Notification Objects				
Name	OID	Position	Specific Code	Description
externalSupplyVoltageAlarmState	.1.3.6.1.4.1.33302.30.5.11.0	0	6	Supply voltage alarm state
supplyVoltage	.1.3.6.1.4.1.33302.30.1.12.0	1	6	Supply voltage value

RSSI Alarm Detection Notification				
Notification Name	notificationRssi			
Notification OID	.1.3.6.1.4.1.33302.30.10.7			
RSSI Alarm Detection Notification Objects				
Name	OID	Position	Specific Code	Description
radioRssiAlarmState	.1.3.6.1.4.1.33302.30.5.13.1.2.1	0	7	Radio RSSI alarm state
radioRssiValue	.1.3.6.1.4.1.33302.30.2.8.1.2.1	1	7	Radio RSSI value

Transmit Power Alarm Detection Notification				
Notification Name	notificationTxPower			
Notification OID	.1.3.6.1.4.1.33302.30.10.8			
Transmit Power Alarm Detection Notification Objects				
Name	OID	Position	Specific Code	Description
radioTxPowerAlarmState	.1.3.6.1.4.1.33302.30.5.14.1.2.1	0	8	Radio Tx power alarm state
radioForwardPower	.1.3.6.1.4.1.33302.30.2.5.1.2.1	1	8	Radio Tx power value

Frequency Error Alarm Detection Notification				
Notification Name	notificationFrequencyErrorChanged			
Notification OID	.1.3.6.1.4.1.33302.30.10.14			
Frequency Error Alarm Detection Notification Objects				
Name	OID	Position	Specific Code	Description
radioFrequencyErrorState	.1.3.6.1.4.1.33302.30.5.18.0	0	14	Radio frequency error alarm state
radioFrequencyError	.1.3.6.1.4.1.33302.30.2.36.0	1	14	Radio frequency error value

SNMP - QB, QP & QH Specific Notifications

Digital Input 1 Notification				
Notification Name	notificationDigitalInput1Notification			
Notification OID	.1.3.6.1.4.1.33302.30.10.20			
Digital Input 1 Notification Objects				
Name	OID	Position	Specific Code	Description
digitalInput	.1.3.6.1.4.1.33302.30.6.2.1.2.1	0	20	Digital input 1 value

Digital Input 2 Notification				
Notification Name	notificationDigitalInput2Notification			
Notification OID	.1.3.6.1.4.1.33302.30.10.21			
Digital Input 2 Notification Objects				
Name	OID	Position	Specific Code	Description
digitalInput	.1.3.6.1.4.1.33302.30.6.2.1.2.2	0	21	Digital input 2 value

Digital Input 3 Notification				
Notification Name	notificationDigitalInput3Notification			
Notification OID	.1.3.6.1.4.1.33302.30.10.22			
Digital Input 3 Notification Objects				
Name	OID	Position	Specific Code	Description
digitalInput	.1.3.6.1.4.1.33302.30.6.2.1.2.3	0	22	Digital input 3 value

Fan Alarm Detection Notification				
Notification Name	notificationFanAlarmChanged			
Notification OID	.1.3.6.1.4.1.33302.30.10.23			
Fan Alarm Detection Notification Objects				
Name	OID	Position	Specific Code	Description
chassisFanStatus	.1.3.6.1.4.1.33302.30.6.4.1.3.1	0	23	Fan 1 Status
chassisFanStatus	.1.3.6.1.4.1.33302.30.6.4.1.3.2	1	23	Fan 2 Status

Configuration Save / Load (WUI)

Any single radio configuration can be saved to a configuration file. The configuration file can be used to duplicate a radio's configuration or as the basis for another remote radio's configuration.

To save or load a configuration file, browse to Setup -> Save / Load.

Save Configuration

As of firmware version 1.5.0, there are two modes for saving a configuration file:

- **Standard:** Saves a configuration file including standard configuration parameters (i.e. Network, Radio, COM1/2, etc).
- **Standard with Passwords:** (Only available when logged in with unrestricted access)
Saves a standard configuration file which includes secure information. Secure information includes:
 - Configuration Security [Enable/Disable]
 - HTTP/HTTPS [Enable/Disable]
 - Telnet/SSH [Enable/Disable]
 - AES [Enable/Disable]
 - SNMP community Strings
 - User Administration information (passwords hashed).

The 'Standard with Passwords' saved configuration file allows an unrestricted user to duplicate the security information saved from one radio into another radio.

NOTICE
<p>POTENTIAL SECURITY RISK</p> <p>A configuration file saved with passwords should be stored in a secure location and only given to those with unrestricted access. The security information in the configuration file is not encrypted (except for user passwords, which are hashed)</p> <p>Failure to follow these instructions can result in cyber security vulnerabilities</p>

Once the Saved configuration mode has been selected, select the 'Save' button.

When a configuration file is saved, the radio will take an image of the current active configuration and create a '.cfg' file. Configuration changes which have not been activated will not be saved.

NOTICE
<p>POTENTIAL SECURITY RISK</p> <p>When saving confidential information such as user names and passwords, use a secure connection to the configuration page such as HTTPS or SSH.</p> <p>Failure to follow these instructions can result in cyber security vulnerabilities.</p>

Load Configuration

To load a configuration file, select the 'Choose File' button, browse to a directory where a configuration has been previously saved and select open. Once the file is selected, select the 'Load' button.

Once the configuration file has loaded, press the 'Activate' button.

NOTICE
<p>POTENTIAL SECURITY RISK</p> <p>When loading confidential information such as user names and passwords, use a secure connection to the configuration page such as HTTPS or SSH.</p> <p>Failure to follow these instructions can result in cyber security vulnerabilities.</p>

Configuration Save / Load (TUI)

Trivial File Transfer Protocol (TFTP) Client

As of firmware 1.4.0, radio configuration files can be saved and/or loaded via TFTP. TFTP file saving/loading is available within the Text User Interface (TUI) only.

In order for a TFTP file transaction to occur, the embedded TFTP client within the radio, requires a connection to an active TFTP server. TFTP server software is available on the internet, where they can be installed on a PC and operate in the background.

To access the radio's TFTP client within the TUI, explore to: Configuration -> Configuration file Load or Save

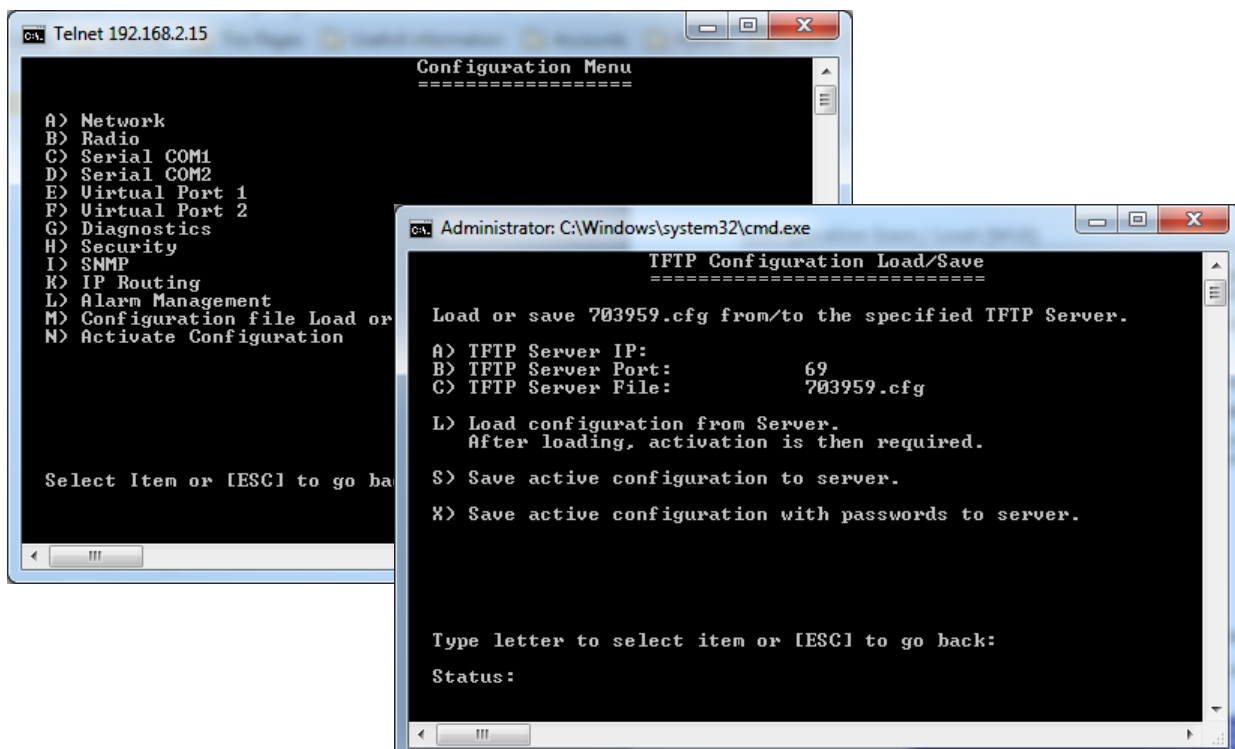

To connect to the TFTP Server, the following parameters are required by the TFTP Client:

TFTP Server IP: Specify the IP address of where the TFTP server resides (the TFTP server can be connected via a radio link or directly connected to the radio)

TFTP Server Port: Specify the IP port number in which the TFTP server is listening on. (Default: 69).

TFTP Server File: Specify the name of the file being saved/loaded. (Default file name is the serial number of the radio) If the name is changed from default, only alphanumeric characters, without spaces can be used.

Load configuration from Server: Using the information provided in the previous parameters, the TFTP Client will attempt to:

- Establish a connection with a TFTP server at the specified IP address and port number.
- If a connection is successful, the client will then request from the server, a configuration file to load into the radio (a previously stored configuration file within the TFTP Server is required). The name of the file requested is that which is specified within the TFTP server file parameter. Ensure that the spelling and case sense of the file name is correct.
- Once the file is successfully loaded in to the radio, use Escape to browse back to the main menu, to allow activation of the loaded configuration file.
- Once the configuration file has been activated, if the new configuration contained a different IP address from the previous configuration and the TUI connection had been established via an IP connection, a new IP connection may need to be established (i.e. new Telnet session) targeting the new IP address of the radio.

Save active configuration to Server: Save the active configuration file of the radio to the TFTP server specified. The name of the file saved will be that which is specified within the TFTP server file parameter.

Save active configuration with passwords to Server: Save the active configuration file including secure information of the radio to the TFTP server specified (for details on saved secure information, see 'Configuration Save / Load (WUI)'). The name of the file saved will be that which is specified within the TFTP server file parameter.

Security

User Administration

Available as of firmware version 1.5.0.

User administration allows an administrator to create individual users with associated levels of radio access privileges.

User administration can be accessed by browsing to: Setup -> Security

Enable 'Security' for the access control table to become visible (Security is enabled by default).

Administration

Security Enabled Disabled

Users

Enabled Username	Password	Access	Access Comment
<input type="button" value="Add"/>			

To add a new user, select the 'Add' button at the bottom of the Users table.

An empty row will be added to the table, with five configurable fields.

Enabled Username	Password	Access	Comment
<input type="checkbox"/>	<input type="text"/>	<input type="text"/>	<input type="text"/>
		Unrestricted ▼	<input type="text"/>
<input type="button" value="Remove"/>			

Enabled: Check box to enable/disable a user account (without removing it from the table)

Username: The user name can only consist of letters and/or numbers and can be 1 to 30 characters long. (No two users can have the same user name).

Password: The password can be between 6 and 30 characters long.



- When the password field is selected, a password window will appear.
- The password window prompts for the password to be populated twice, to help ensure that the characters entered are as expected (if the passwords do not match, a message will appear).
- For security purposes, the password characters are always hidden behind black dots.

Access: Defines the access privilege level for the user being created.

There are four access privilege levels to select from:

Access	Privileges
Unrestricted	No restrictions to user access
Read/Write/Sec	Allows configuration of all items except for user administration
Read/Write	Allows configuration of all items except for user administration and security
Read Only	Read only

Comment: An optional field for a profile description.

User Administration configuration example:

The following user administration table shows four users configured, one for each priority access level:

Enabled	Username	Password	Access	Comment	
<input checked="" type="checkbox"/>	Admin	*****	Unrestricted	Administrator	Remove
<input checked="" type="checkbox"/>	User1	*****	Read/Write/Sec	Security Access	Remove
<input checked="" type="checkbox"/>	User2	*****	Read/Write	Write Access	Remove
<input checked="" type="checkbox"/>	User3	*****	Read only	Read Access	Remove

Logging in:

Once the configuration is activated, the configuration page will prompt for log in credentials to allow access to the radio:

LOGIN REQUIRED

User:

user

Password:

password

Enter the log in credentials and select the 'Login' button.

If entered correctly, the Home page of the radio will be displayed along with the user name and access level shown within the page banner (Circled in RED below):



Serial Number: 703050
 Model: QR450
 Firmware Version: 1.1.0.6K75
 Copyright © 2010 Schneider Electric. All Rights Reserved.

Without log in credentials, users will have access to the radio's monitoring page, where the radio's diagnostic information and basic unit information is available.

NOTICE

POTENTIAL SECURITY RISK

When configuring confidential information such as user names and passwords, use a secure connection to the configuration page such as HTTPS or SSH.

Failure to follow these instructions can result in cyber security vulnerabilities.

AES Encryption

When encryption is enabled in a network, all data sent over the air is encrypted and can only be read by radios sharing the same Encryption Key. Encryption must be enabled in each radio in a network. The encryption key is 256 bits long and is entered as string or a hexadecimal number. For maximum security the chosen key should be one that is difficult for an intruder to guess.

Once written into the radio using the programmer, it is not possible to read the encryption key so care must be taken to record the key in a safe place.

Encryption Key: String

For a string type of key, use up to a maximum of 64 printable characters. Observe that the key is case sensitive.

Some examples are:

TRIO2012

Murray River Region

Encryption Key: Hexadecimal Number

Hexadecimal numbers can have a value of 0 to 15 and are represented by 0-9 and A, B, C, D, E or F.

A hexadecimal key begins with 0x and has up to 64 digits following.

Use an even number of hexadecimal digits.

Some examples are:

0x1234

0x123456789ABCDE

0x11111111222222223333333344444444 up to 64 digits

Configuration of AES is done via Setup -> Security

Encryption

Encryption

AES ▼

Shared Key

.....

Part I – Installation & Commissioning

Introduction

All Q data radios need to be properly installed and commissioned in order to function reliably. Installers should be familiar with RF products / installations and are equipped with appropriate tools necessary to help ensure that the ongoing reliability of a communications system.

This is a short form guide to assist with the correct installation and commissioning of Q data radios and help ensure that useful tests are made and recorded at each site for future reference should an issue arise.

Installers should check that each Q data radio has been programmed to suit their requirements before installation.

Installations play a role in network performance. The installation should be performed in a professional manner with careful consideration to the following items:

1. Adequate primary power cable - relative to the length of cable to minimise voltage drop.
2. Shielded CAT-5 or CAT-6 Ethernet patch cable between the Q data radio and any external Ethernet equipment.
3. Shielded RS-232 data cable between the Q data radio and any external RS-232 equipment.
3. Low loss coax used for antenna feed line.
4. Careful termination of RF connectors.
5. A suitable antenna for the requirement.
6. Suitable placement of the antenna.
7. Adequate signal strength from the master radio.

TYPICAL INSTALLATION OVERVIEW

The following information should assist when installing and commissioning a Q data radio Ethernet system.

DATA CONNECTION

In industrial environments connection to any external device should be by shielded CAT-5 or CAT-6 patch cable. A cables should be routed with strain relief.

MOUNTING

The radio modem should be mounted in a cool, dry, and vibration free environment. Mounting of the unit should be in a location providing easy access to mounting screws and all connections. Q Data radios can operate within a -40...70°C (-40 to 158°F) ambient environment.

POWER SUPPLY REQUIREMENTS (QR)

Rated Operating Voltage: 10...30 Vdc
 Input Power (Rx typical): 5 Watts
 Input Power (Tx typical): (See table below)

Tx Power (dBm)	Typical Input Power (Watts)	
	QR150	QR450
30	18	24
37	28	37
40	39	52

The QR is supplied with a lock-in mating DC power connector which should be installed with the locking screws done up tightly (0.5 - 0.6 Nm / 4.42 - 5.31 ftin).

The radio is designed to limit damage if the voltage exceeds 30 Vdc or if reverse polarity is applied. The field replaceable internal fuse has a 7 Amp rating.

POWER SUPPLY REQUIREMENTS (QB)

Operating Voltage: 11...30 Vdc (Dual Input)
 Input Power (Rx typical): 14 Watts
 Input Power (Tx typical): (See table below)

Tx Power (dBm)	Typical Input Power (Watts)	
	QB150	QB450
30	26	34
37	38	46
40	46	59

In high ambient temperature situations, the internal fans may operate, resulting in an increase of input power of up to 28 Watts.

Typical receive/standby input power is 14 Watts. The input power will vary in transmit mode according to RF output power level.

The QB is supplied with a lock-in mating DC power connector which should be installed with the locking screws done up tightly (0.5 - 0.6 Nm / 4.42 - 5.31 ftin).

The radio is designed to limit damage if the voltage exceeds the operating voltage or if reverse polarity is applied. The field replaceable internal fuse has a 12 Amp rating.

Before proceeding with any wiring to the radio, refer to the wiring safety notices within the preface of this document.

Connect and secure the Antenna, Ethernet and Serial plugs BEFORE applying power to the unit. Lastly, before inserting the power plug, re-check that the terminals being used, polarity and voltage on the DC power plug is correct using a multimeter and check the power cable against the +/- label on the power input socket.

COAX CABLE CONNECTION

Select the appropriate cable and connectors for each application; selection can impact on the performance of the system.

As an example, for each 3dB of cable and connector loss, half the transmitter power is lost and twice the receiver signal power is required to produce the same RF link performance.

In some installations where strong signals are present, a compromise of cable and connector cost may be acceptable.

All connector terminations should be performed as per the manufacturer's specifications; and if connectors are to be used outside, use a sealant such as amalgamating tape to seal connectors. Acetic cure silicon to seal the connectors is not advised.

Coax cables should not be stressed by tight bends, kinking or excessive flexing. Ensure that coax cables have sufficient strain relief and are secure. If large-diameter rigid or semi rigid cable is used, it is recommended to use a short length of high quality RG223 cable between the unit and main cable feed.

ANTENNA INSTALLATION

The selection of antennas and their placement can influence RF link quality.

Antennas are generally mounted to a vertical pole with either vertical or horizontal polarisation as per the license requirement.

Antennas should be mounted as high as practical and away from metal surfaces which can cause reflections.

As a typical generic example for selecting the suitable antenna type, Point to Multipoint (PTMP) systems generally employ high gain (3, 6, or 9dB gain) omni directional antennas at the Entry Point/Repeater sites and either omni directional whips (unity gain) or preferably high gain directional yagi antennas (9 or 14dB gain) at the remote sites.

YAGI ANTENNAS

Yagi antennas not only provide signal gain and directivity, but also provides protection from interfering signals which are outside the beam width of the antenna. Yagi antennas help provide optimum performance when communicating over very long distances.

Yagi antennas are polarised and need to be mounted either vertically (elements pointing from the ground to the sky) or horizontally (elements in parallel with the horizon).

When mounting yagi antennas with vertical polarisation, it should be noted that some antennas have a drain hole in the dipole (loop section of antenna). The small drain hole on one end of the dipole must be pointed towards the ground so that water will drain out of the antenna.

OMNI DIRECTIONAL ANTENNAS

Omni directional antennas provide a radiation pattern of equal strength through 360° in the horizontal plane. This makes them ideal for Entry Point /Repeater radio antennas in point to multipoint systems because they can reach a large populous of remote sites.

Omni directional antennas are also used at remote sites (although yagi antennas are preferred) and are typically ground independent whip type antennas. The main reason for using whips at remote sites is for aesthetics as they are far less obtrusive than a yagi.

Regardless of the type, antennas need to be mounted properly and in a suitable location as covered below.

ANTENNA PLACEMENT

Antenna placement is of paramount importance and plays a big part of the antennas and in turn systems performance.

When choosing antenna locations the aim is to find the largest path of unobstructed space and locate the antennas within that space. Locate the antennas as high as possible and clear of any obstructions.

Where possible, avoid mounting antennas:

1. Against or adjacent to steel structures.
2. In an area which will have intermittent obstructions - people walking past, vehicles driving past etc. That is, mount antennas well above such moving obstructions.
3. Near any electrical equipment.
4. Near metal beams, structures etc.
5. Inside any metal enclosures, tin sheds / warehouses etc. - (Some meshed wire fences act like a “brick wall” to RF transmissions).
6. Away from guard rails or support beams.
7. Above any pipe work or corrugated iron roofs.

Sometimes installations in such environments are unavoidable and where this is the case, certain care can be taken to help ensure a reliable installation.

If tests indicate poor signal strength then the antennas at one or both ends of the link should be raised, and/ or moved clear of obstructing objects, or if directional antennas are employed they should be checked for correct directional orientation and polarisation (horizontal or vertical signal orientation).

LED Indicators

LED indicators are documented in Part E - Quick Reference Guide - Hardware of this User Manual. However, during the installation process check that the LED indicators are operating correctly.

DC POWER

If all the LEDs are off, no DC power is reaching the radio modem or the fuse is open. Successful power-up is indicated by the “Pwr/Tx” LED showing a continuous GREEN state.

When the transmitter is active the “Pwr/Tx” LED turns RED.

Sync/No RX LED Indicator



The “Sync/NoRx” LED is used to indicate the state of the receiver.

A solid or regular flashing GREEN LED shows that the modem is receiving decodable data.

A solid or flashing RED LED indicates the modem is receiving un-decodable data, this is typically from an unwanted source.

ETH port LED Indicators

See the table below for Ethernet port LED indicators.

ETH1/2 LEDs	
Ethernet port inactive, no cable connected	
Ethernet port active @ 10Mbps	
Ethernet port active @ 100Mbps	

Optimising the Antenna for Rx Signal

When using a directional antenna, it will be necessary to align the antenna to achieve optimal received signal. This can be done using TVView+ Diagnostics (measured RSSI) or by measuring the RSSI output on Pin 9 of the serial COM port.

This can be done by using the (0-5Vdc) output on Pin 9 of the serial COM port to indicate signal strength (RSSI). This voltage can be converted to dBm using the chart below.

The RSSI output will peak latch for 3 seconds.

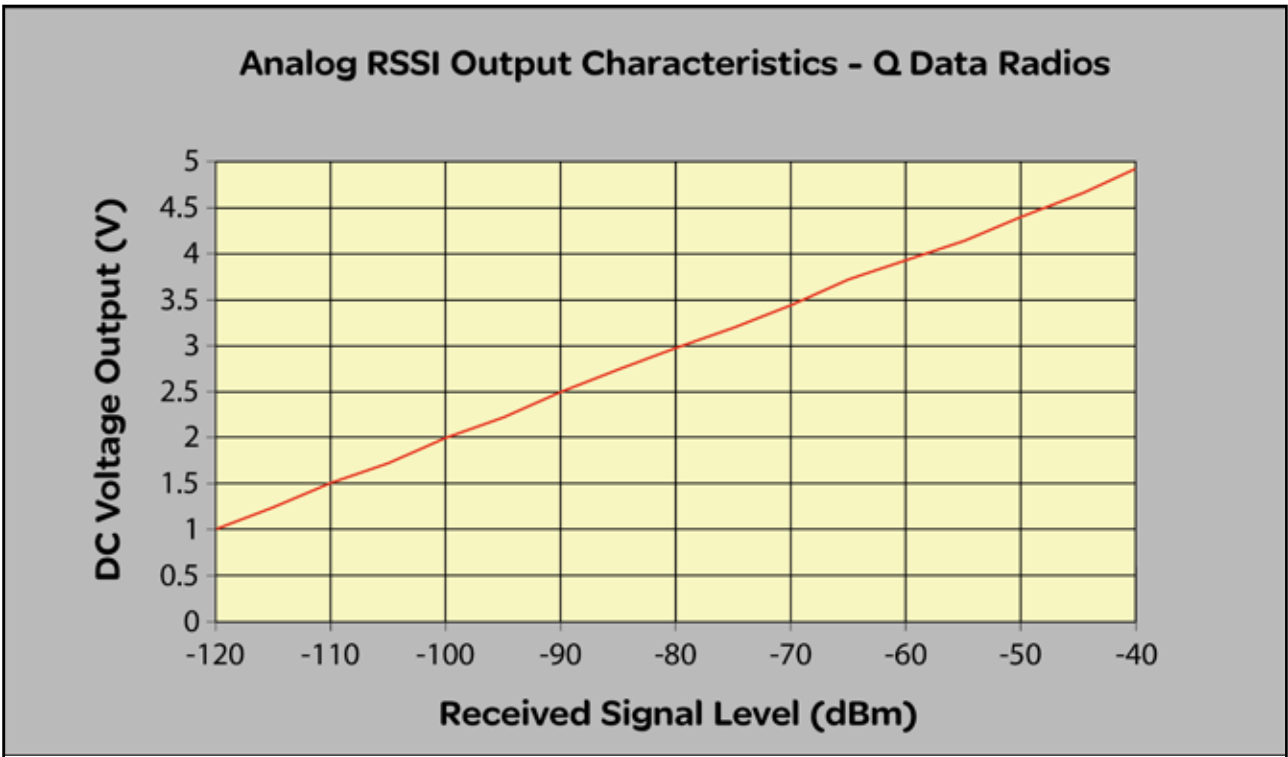
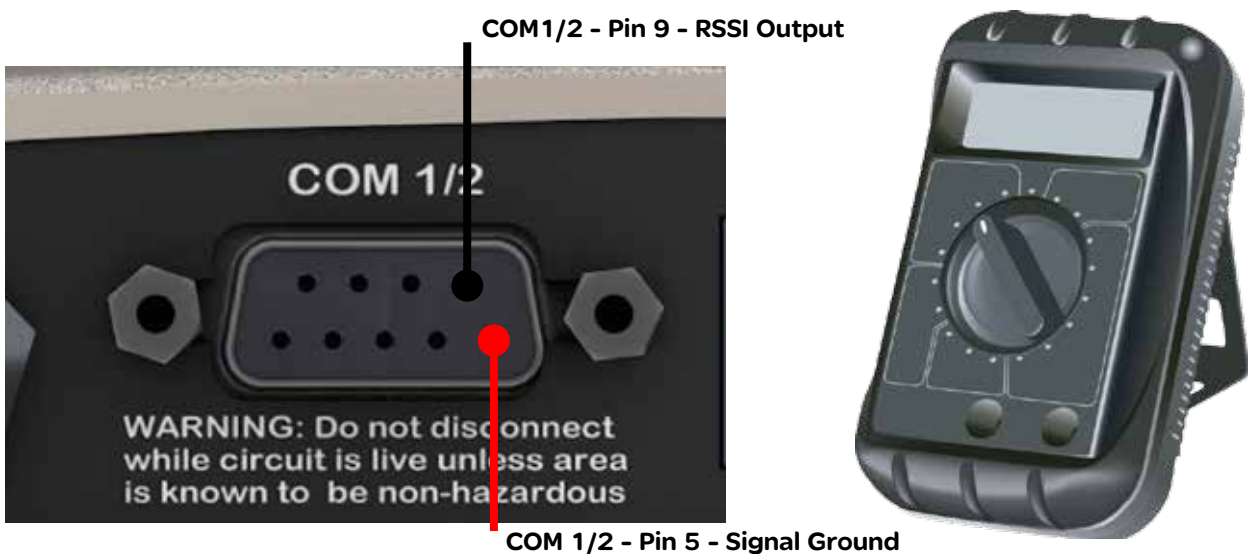

Chart is approximate only.



Commissioning

When commissioning an Ethernet radio network, ensure that the incoming received signal strength (RSSI) is adequate to provide reliable communications.

In order for a system to operate reliably, an “adequate” signal level needs to be present which allows for fading and interference.

An adequate level is typically 20 to 30dB above the minimum threshold of the receiving device. Using the dynamic RF data rate can allow the minimum threshold specification to be taken from the lowest available data rate of the bandwidth being used.

Should this level not be achieved, then either;

1. A more suitable location to mount the antenna.
2. The antenna will need to be mounted higher in a more prominent location to achieve as close as possible to clear line of site.

HTML Diagnostics

Overview

After the Q data radios have been configured and installed, the next step in the commissioning process is to review the HTML diagnostics available in every radio. Diagnostic parameters available are shown in the image below:

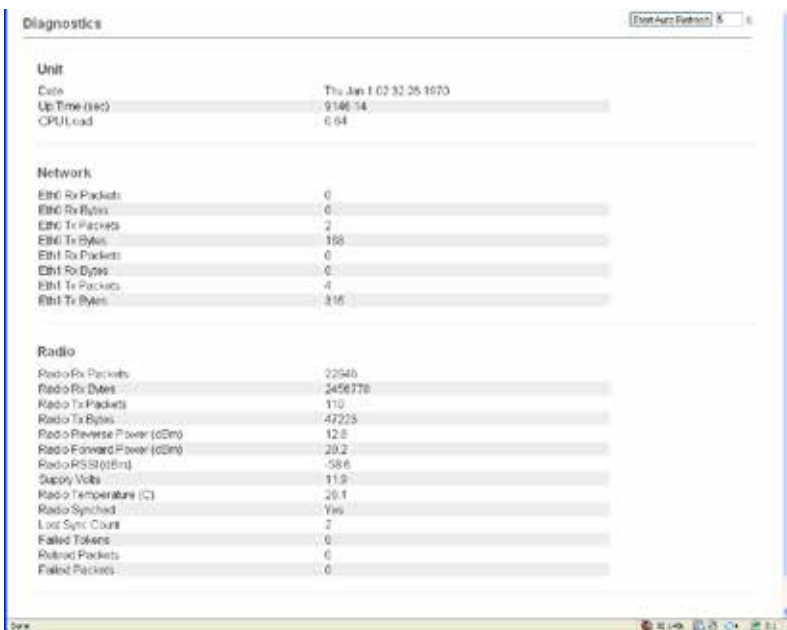

Unit Specific:

Date: Specifies the current date and time. For the date and time to be correct the radio needs to be configured to synchronise with a NTP Time Server.

CPU Load: Specifies the amount of CPU load the linux based kernel is experiencing.

Network Specific:

ETH 1 Rx Packets: The number of Ethernet packets received on ETH1.

ETH 1 Rx Bytes: The number of bytes received on ETH1.

ETH 1 Tx Packets: The number of Ethernet packets transmitted on ETH1.

ETH 1 Tx Bytes: The number of Ethernet packets received on ETH1.

(The same applies for ETH2)

Radio Specific:

Radio Rx Packets: The number of packets received by the radio.

Radio Rx Bytes: The number of bytes received by the radio.

Radio Tx Packets: The number of packets transmitted by the radio.

Radio Tx Bytes: The number of bytes transmitted by the radio.

Radio Reverse Power (dBm) : TX Reverse power measured in dBm.

Radio Forward Power (dBm): TX Forward power measured in dBm.

Radio RSSI (dBm): The RSSI (Received Signal Strength Indicator) measured in dBm.

Supply Volts: The DC supply voltage measured in dBm.

Radio Temperature (C): The internal radio temperature measured in degrees Celsius.

Retired Packets: The number of packets that were discarded after ARQ retries and time outs were exhausted.

Failed Packets: The number of incoming packets that have failed CRC check and have been discarded.

Part J – Firmware Updating and Maintenance

Firmware Updating

Introduction

Schneider Electric work towards providing enhancements and improvements to the firmware for the Q data radios. It is recommended that you keep the Q data radios up to date with the latest firmware releases.

The following instructions can be used to upgrade firmware in any Q Data Radio.

Using a standard web browser you can connect to a Q data radio and inspect the current firmware version which is displayed on the home page of the Web User Interface.

For new firmware updates which may be beneficial to your system, check the Schneider Electric web site:

<http://www.schneider-electric.com/>

To access the Trio radio section of the website, browse to: Products -> Automation and Control -> Telemetry and Remote SCADA Systems.

Download the firmware pack from the website and store it on your PC or in a location on your computer network which can be accessed during the firmware update process.

Firmware updates can be performed on a unit connected locally to the PC or remotely via an operational radio link. For a local upgrade, it is recommended that all other cabling to the unit be disconnected prior to commencing the firmware update to minimise any interruption to the process or disturbances of signals on cables still connected.

For remote upgrades, it is advised to use the global firmware update tool.

The firmware update process is two part. First, the firmware is transferred from the PC to the Q data radio alternate firmware image via the HTML browser. This is called "uploading and unpacking" the firmware. This typically takes several minutes. The second process involves the user activating the alternate firmware pack, which causes the radio to swap current firmware with the alternate, and re-boot. This typically takes between 5 to 6 minutes, depending on how much firmware needs to be updated.

Firmware is distributed inside a ZIP file that contains a full firmware image as well as patch files. Patch files contain only the differential set of changes based between two specific firmware versions, hence they are smaller and take less time to transmit over the air than a full firmware file.

Full firmware images should be applied when locally firmware upgrading the radio. Patch files are designed for use with the global firmware upgrade software tool (see below), which automatically inspects the target radios current firmware version and chooses the correct patch file to send. Patch files can also be loaded manually via the firmware upgrade page in the web browser, however the correct patch file needs to be manually selected.

Both full and patch file methods only apply changes to the alternate firmware pack. Once the changes are applied, a separate user initiated process will activate the alternate firmware pack. This activation can be done both via the web page interface and via the global firmware upgrade software tool.

Firmware Updating and Factory Default Information LEDs

In some circumstances a firmware update or factory default might be required. A special LED sequence is shown during this phase.

	COM 1 Rx/D / Tx/D	COM 2 Rx/D / Tx/D	Sync / RxSig	Pwr / Tx
Firmware upgrade	Amber	Amber	Amber	Amber
Factory Defaults	Green	Green	Green	Green

Firmware Upgrade: All LEDs flash AMBER (as shown in table above) - 1 second ON and 1 second OFF

Factory Default: (as shown in table above) will first illuminate all LEDs to a solid green state to indicate a factory default process has been initiated. Once the factory default process has begun, the LEDs will begin a sequence of flashing green LEDs until the process has been completed.

Firmware Update Procedure

Ensure that an Ethernet cable is connected from the PC's LAN port to an Ethernet port of the Q data radio, and the unit's IP address is entered into the web browser. Check the serial number displayed in the HTML page against the Q data radio that you are about to update. The serial number can be found in center of the home page as shown across the page.



Serial Number: 700187
Model: TBURQR450-01000049
Firmware Version: 1.0.0.2478
Copyright © 2012 Schneider Electric. All Rights Reserved.

1. Click on the 'Maintenance' button located along the top of the page.
2. Select the 'Firmware Management' button along the left hand side of the page. The firmware upload page will now be displayed as shown below.



3. To select the new firmware pack you wish to upload, click on the Browse/Choose File button.
4. Locate the .tpk file which contains the new firmware. Select the file and click on "Open". The page should now display the name of the .tpk file chosen in the upload firmware pack section.
5. Click the 'Upload Firmware' button. If there is an existing firmware pack located in the Alternate Firmware section, the radio will display a message, indicating that the alternate pack is about to be over written by the new firmware pack. Click OK to continue.
6. This process can take up to 10 minutes, wait until the new firmware pack is displayed within the Alternate Firmware section.
7. Once the firmware has successfully uploaded and unpacked in to the alternate firmware location, click the 'Activate Alternate' button.
8. During this phase, all 5 LED indicators will flash amber simultaneously. After 4 to 5 minutes the Q data radio will re-boot and the new firmware will be activated.

After a successful activation, the new firmware pack should be displayed within the 'Current Firmware' section.

Global Firmware Updating

Introduction

The TView+ Management Suite software provides a facility to perform Global firmware updates to every Q data radio within a network over the RF channel. The Global firmware update facility uses two techniques to limit the impact on user data. For instructions on installing TView+ Management Suite, refer to the TView Diagnostics User Manual.

1. Data rate-limiting which trickles the data onto the RF channel at 5% of the channel capacity.
2. Differential firmware packs (patch files) dramatically reduce the size of the file needed to be sent over the RF channel.

The combination of these two features allows seamless operation of SCADA traffic while the update is in progress.

The firmware upgrading tool is rate-limited to minimise impact on user data. The uploading process will take some time. Allow up to 24 hours to complete.

Minimum Programmer Requirements

TView+ Programming software Version 3.25.0 (Build 19) onwards.

(It is recommended to upgrade to the latest version of TView+ Programming software).

Connection

Ethernet connection between the PC and the ETH port of the entry point radio. This tool distributes firmware to the broadcast address of a subnet. If network routers/layer 3 switches/Firewalls or MAC layer filters are located on the Ethernet connection between the PC and the entry point radio, ensure that broadcast packets are not being blocked/prevented to allow the tool to work.

IP Routing Mode

When targeting the network address of the radio network while in IP routing mode, the radio WAN subnet is used.

As the entry point radio is operating as an IP router, a configuration to allow broadcast packets to pass is required.

Within Setup -> IP Routing -> Advanced, enable the parameter 'Directed Broadcast'. This will allow directed broadcasts between LAN/WAN.

Repeating Broadcast Messages

Within an IP Routing mode radio topology which includes a repeater, a configuration to repeat broadcast messages is required.

Within Setup -> IP Routing -> Advanced, enable the parameter 'Forward Broadcast'. This will allow forwarding of broadcasts received on the WAN back on to the WAN.

Ethernet Filtering

As the global firmware upgrade tool sends broadcast packets as a means of reaching each remote radio, ensure that Ethernet filtering is not enabled within the entry point radio, which would prevent the firmware upgrade broadcasts from being sent on to the radio channel.

Step by step instructions

1) Radio Pre-Configuration: Before performing a global firmware upgrade, ensure that each radio being upgraded has been pre-configured with the following common settings:

- **SNMP:** The firmware upgrade tool utilises the SNMP protocol, therefore, each radio requires the following pre-configuration:
 - **SNMP Enabled:**
 - **SNMP Version:** V1 or V2c
 - **Read/Write Community String:** (default sting is: private)
- **Mask:** The firmware upgrade tool will address packets to the radio network’s broadcast address. The broadcast address of a radio is defined by the subnet mask.

2) Open the Firmware Upgrade Tool: Open TView+ Management Suite, select the ‘Firmware Update’ button. This will open the Firmware upgrade page. Once open, select the ‘Q-Series Firmware Upgrade’ Button. This will open the Global Firmware Upgrade tool for Q-Series.

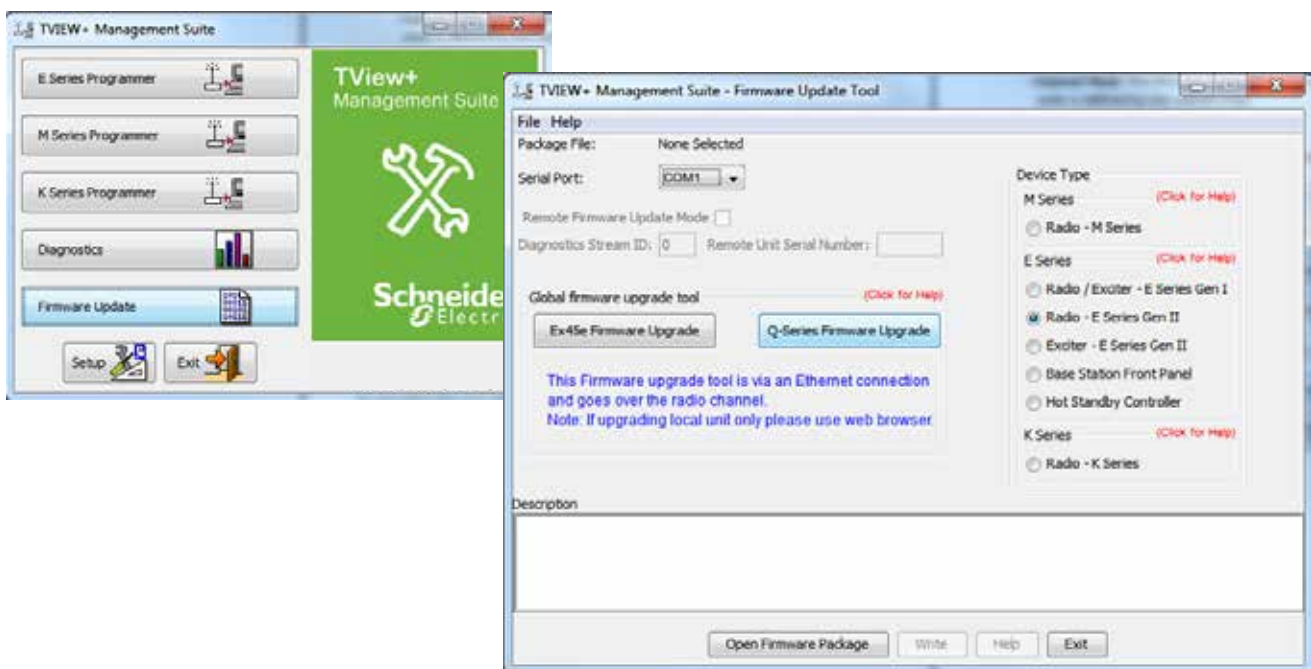

This will open the Global firmware upgrade tool.

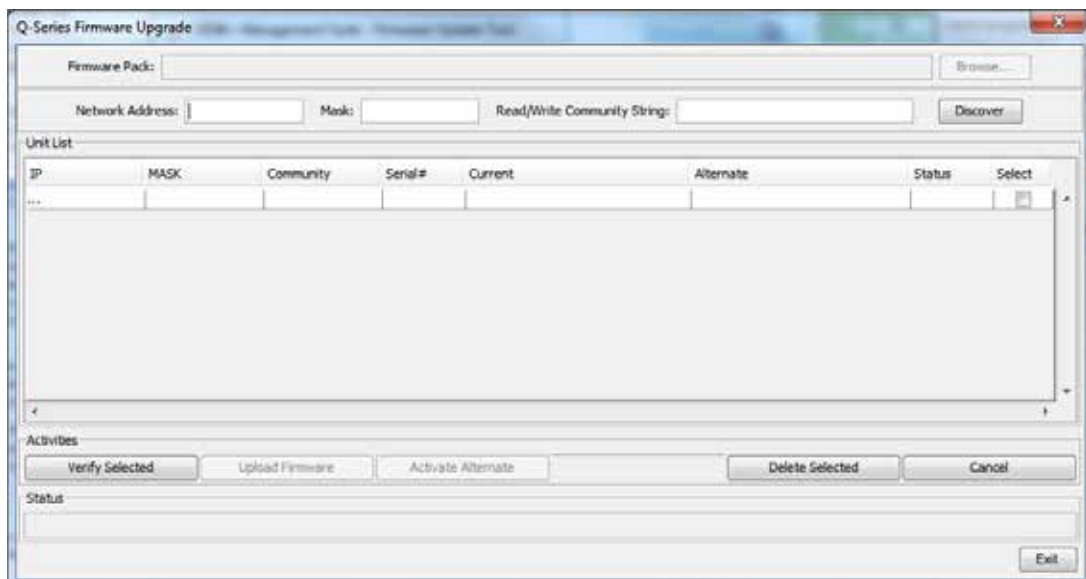

2) Configure the Firmware Upgrade Tool: The firmware upgrade tool requires the following parameters to allow communication with each of the radios being upgraded.

- **Network Address:** This parameter defines the base (beginning) IP Address of the subnet. Otherwise known as Subnet IP, Base Address or Subnet ID.

For information on how to determine what the network address of your radio system is, see your network specialist or refer to a network calculator such as the one found at this address: (<http://ipcalc.nmonitoring.com/>).

- **Mask:** The mask is used to define the range of the subnet. Used in conjunction with the Network Address, the firmware upgrade tool can determine:

- Where the subnet starts
- How many IP addresses are within it
- Where the Subnet ends (The last address within a subnet is always allocated as the broadcast address)

- **Read/Write Community String:** Set the same Read/Write Community String within all of the target radios.

Example - Configuring the Firmware Upgrade tool: The diagram below shows a typical PTMP system along with the configuration parameter values required by the Firmware Upgrade tool.

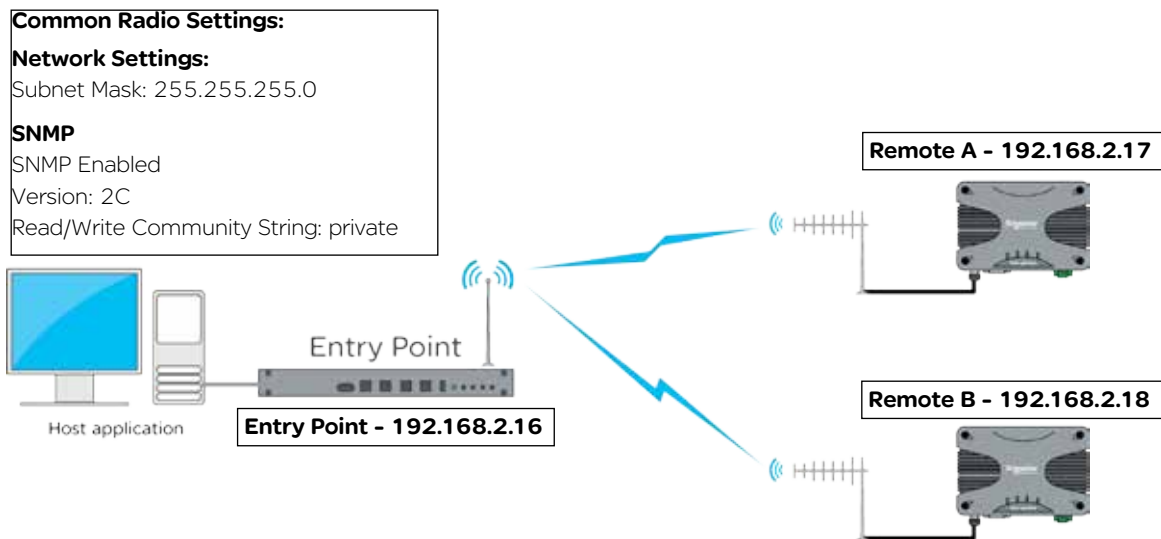

The Network Address, Mask and Read/Write Community String have been configured to reflect the radio diagram above.

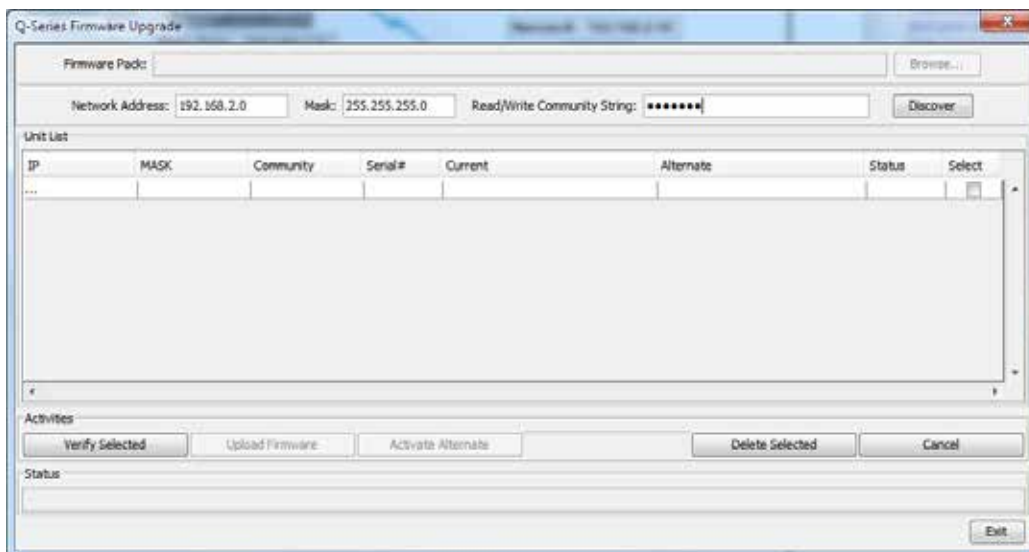

3) Radio Discovery: Once the firmware upgrade tool has been configured with the Network Address, Mask and SNMP Read/Write Community string of the radio network, the radios can be discovered, and can populate the table. There are two methods for radio discovery:

- **Auto Discovery:** By selecting the ‘Discover’ Button, the tool will automatically interrogate each IP address within the Subnet range defined by the mask. If any devices are discovered during this process, the table will be automatically populated upon discovery completion. Depending on how big the sub net is (how many IP address the tool needs to interrogate) this can take a long period of time to complete. During this time, the progress is shown at the bottom of the window.
- **Manual Population:** When a small number of remotes have known IP addresses, it can be time efficient to manually populate the table (rather than waiting for the tool to interrogate an entire subnet). To perform a manual table entry:
 - Within the Unit List, click inside the white blank box underneath ‘IP’
 - Enter the IP address of a radio, along with the Mask and Community String.
 - A new row will appear for an additional unit (if required) this will continue to happen after every IP address added to the list.

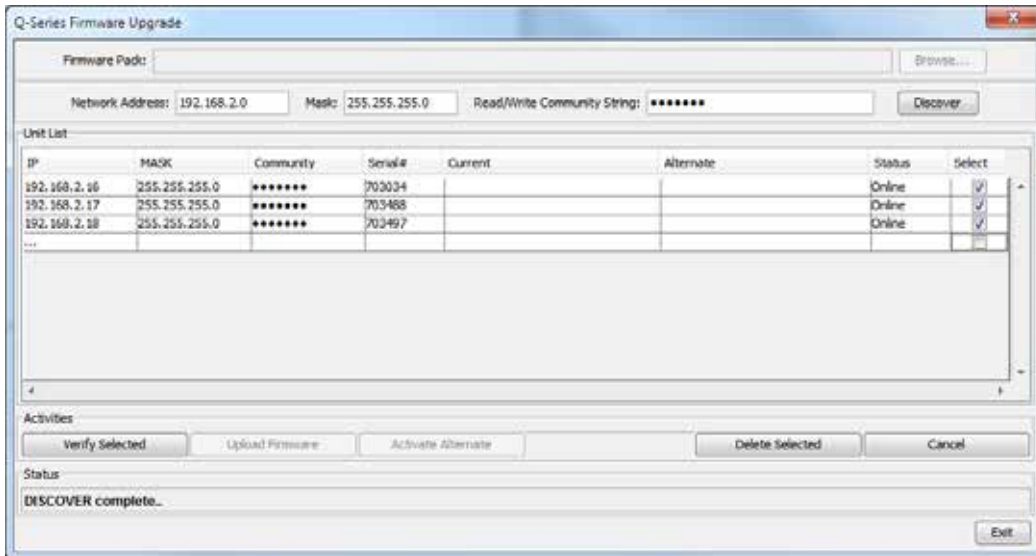

4) Radio Verification: Once the unit list table has been populated (automatically or manually) select the radios which are to be included in the firmware upgrade by checking the select box at the end of the corresponding radios table entry row.

Once the required radios are selected, click the “Verify Selected” button. This begin an SNMP polling cycle to each of the selected radios. The poll cycle will occur every 15 minutes, with 4 seconds between each selected radio. This will verify that each of the selected radio are still present and are able to receive the firmware upgrade broadcasts. To stop the polling or to select a different group of radios, select the cancel button.

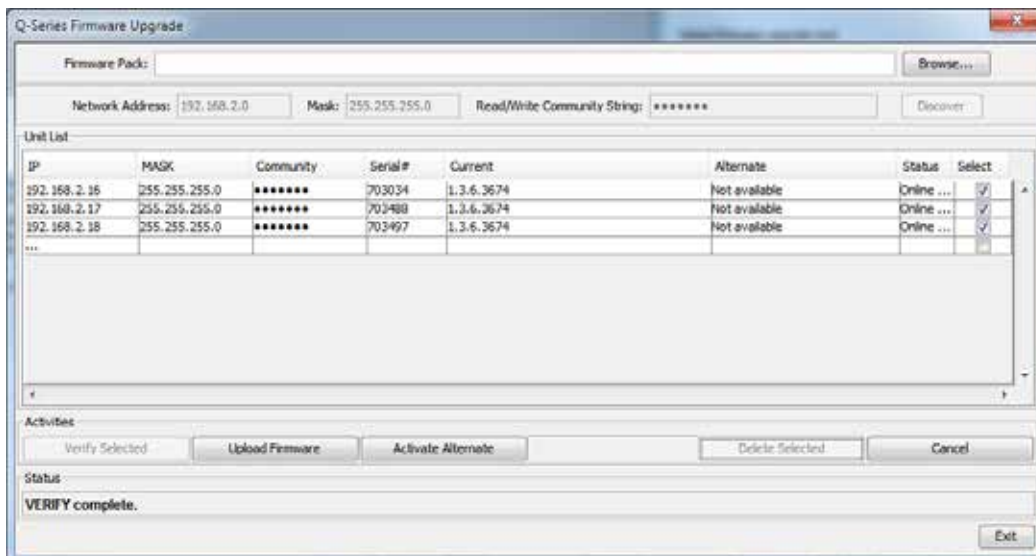

If at any time, a radio needs to be removed from the Unit List table, select the radio in the table and select the ‘Delete Selected Button’.

5) Open Firmware: Once the verification process is complete, open the new firmware pack into the firmware update tool.

During a firmware update, only a small patch file is applied to each radio. These patch files only contain the differences between current operating firmware and the new firmware being upgraded to.

This provides the benefit of only sending small amounts of data over the radio channel, rather than an entire firmware pack. As it is possible to have radios within the same network operating on different firmware packs, a number of different patch files may be required to be sent over the radio channel.

This means, during a global firmware update, the firmware update tool requires all firmware update patches at once. This is done by providing the tool with the global firmware zip package (contains all firmware update patches).

The global firmware zip package is contained within the standard Q Data Radio firmware zip, which can be downloaded from the Schneider Electric website: <http://www.schneider-electric.com/>

To access the Trio radio section of the website, browse to: Products -> Automation and Control -> Telemetry and Remote SCADA Systems.

To open the global firmware zip file within the tool, click the 'Browse...' button and select the firmware upgrade zip package. The global firmware update tool will then select the appropriate patch within the zip file for each radio within the unit list based on each current firmware pack.

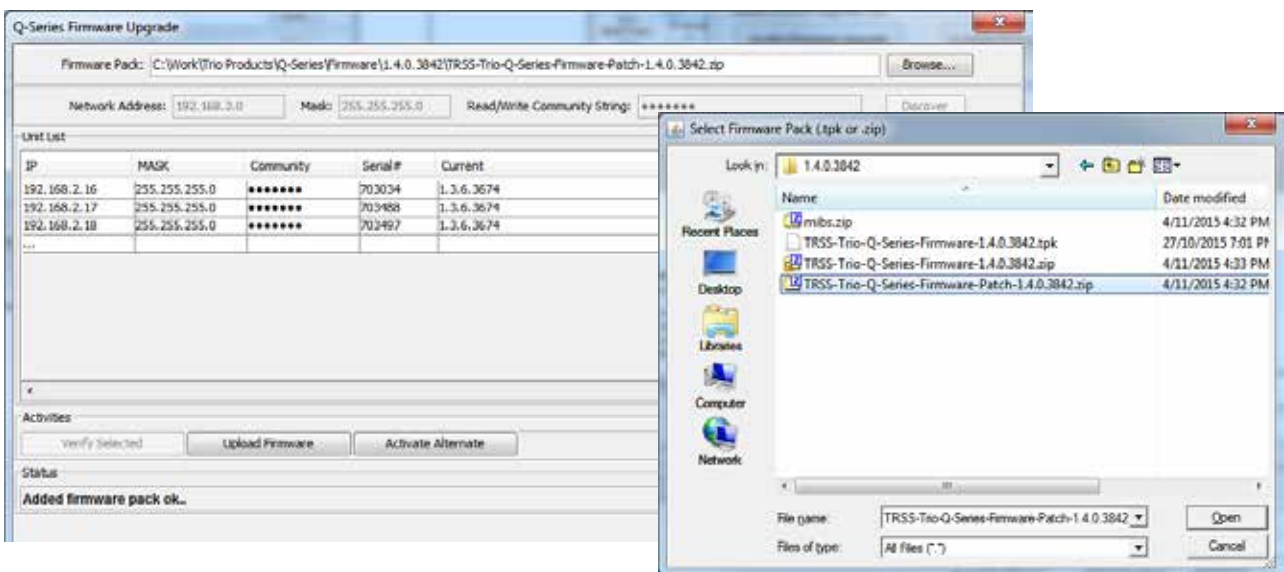

6) Upload Firmware: Once the Firmware Pack is selected, the firmware can be uploaded to the selected radios.

Select the 'Upload Firmware' button. As the uploading is rate-limited to minimise impact on user data, the uploading process will take some time. Allow up to 24 hours, per patch file being broadcast, to complete.

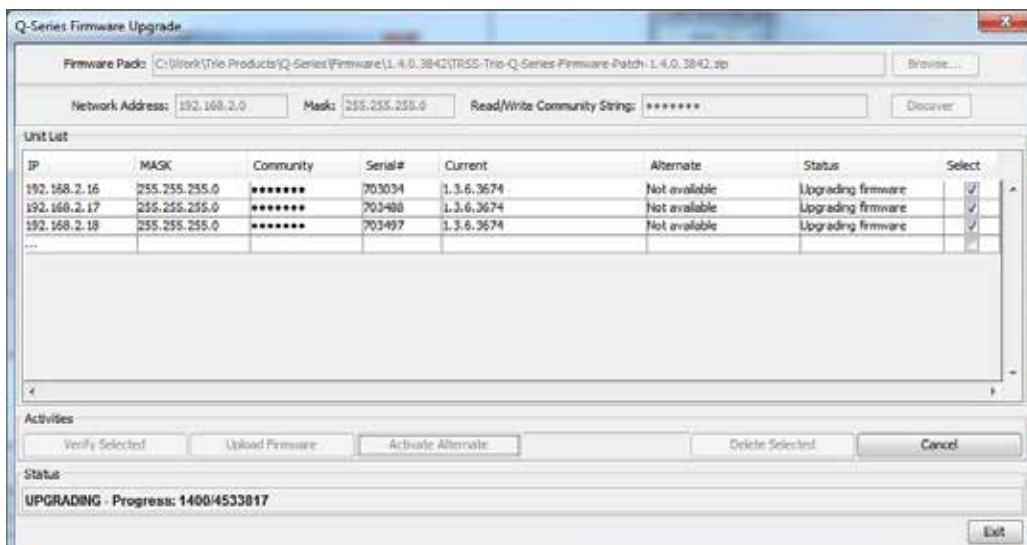

7) Activate Firmware: After the Upload process is complete, the new firmware will be loaded into each selected radios alternate firmware location.

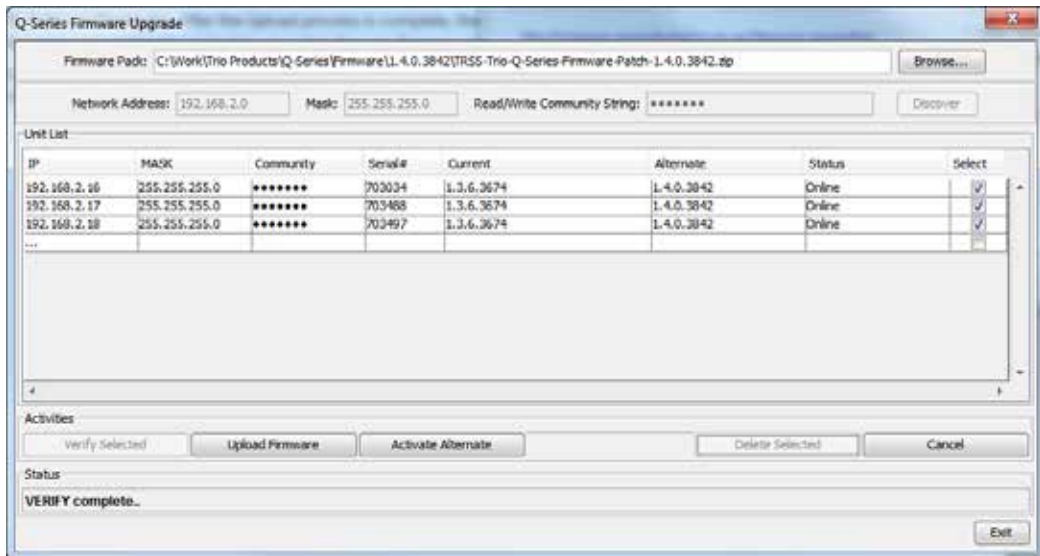

To activate the alternate firmware (which will switch the current and alternate firmware) select the radios requiring an alternate firmware activation, and select the 'Activate Alternate' button. The status column of the radios selected will display an active alternate firmware activation.

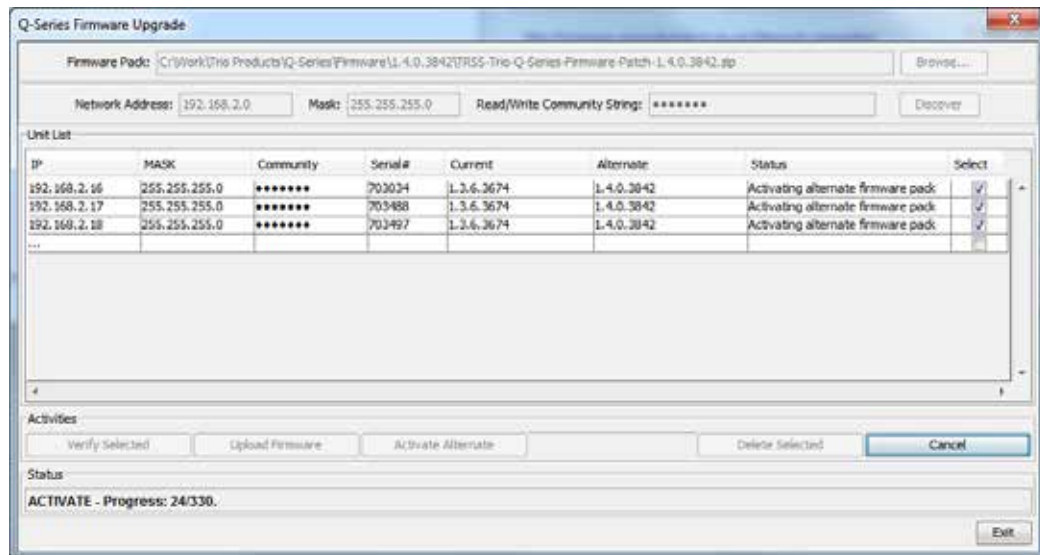

Once completed, the new firmware will be shown in the current firmware column as shown below.

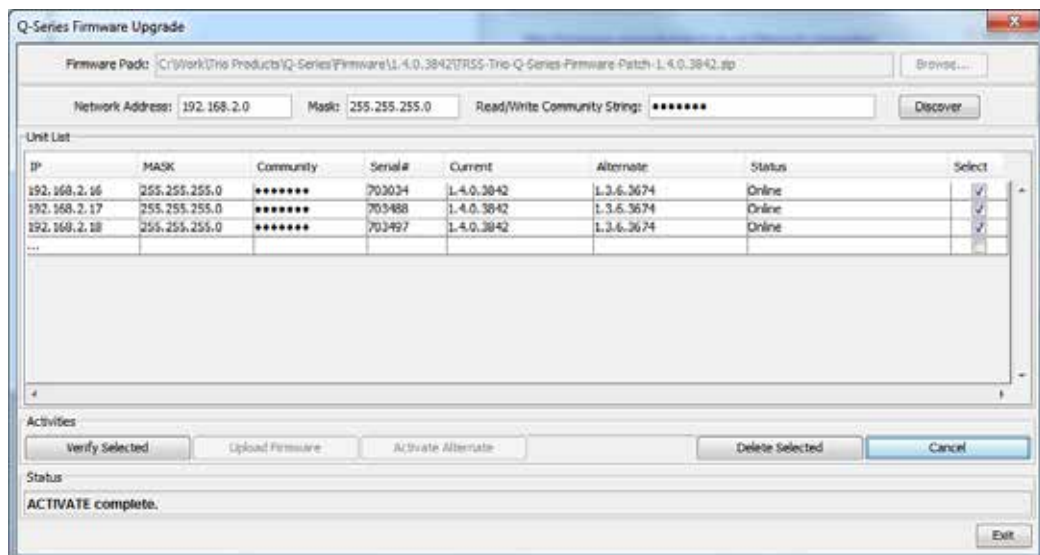

Over-the-air packet capture session (SE Technical Support Use Only)

To assist with support, the radio can capture and record data packets being transmitted/received over the radio channel. Reviewing this capture can help determine whether there is unwanted traffic being sent over the radio channel.

The packet capture files which are logged are encrypted and can only be reviewed by Schneider Electric technical support. The use of this tool will generally be requested from the technical support team.

The over-the-air packet capture session can be accessed in the WUI by browsing to: Maintenance -> Advanced.

To start the packet capture process, press the 'Start' button. Once started a packet capture session will begin. Any existing logs from a previous session will be cleared. A session will continue until the Stop button is selected.

To stop the packet capture session, press the 'Stop' button. Once the session has been stopped,, the captured log files will appear. Log files are date and time stamped and can be downloaded by clicking on the file name link.

A log file's size is limited to 1 MB each, and a maximum of ten Logs can be stored per session. Once the maximum number of logs has been reached, the session will continue by over-writing the oldest log.

As log files are stored within the local radio, over the air retrieval may take some time depending on channel bandwidth and utilization (up to/and 1 MB chunks for multiple files in session capture)

The screenshot shows the Schneider Electric Trio QR450 WUI interface. At the top, there is a green header with the Schneider Electric logo and the device name 'Trio QR450'. Below the header, there are navigation tabs for 'Home', 'Monitoring', 'Diagnostics', and 'Maintenance'. The 'Maintenance' tab is selected, and the 'Advanced' sub-tab is active. On the left side, there is a sidebar menu with options: 'Maintenance', 'Firmware Management', 'Security Management', 'Transmit Test', and 'Advanced'. The main content area displays the following text and buttons:

Selecting the reboot button will force the device to perform a device reboot.

Over-the-air packet capture session (SE Technical Support Use Only).
 Once started a packet capture session will begin. Any existing logs from a previous session will be cleared.
 A session will continue until the Stop button is selected.
 Once the session has been stopped, log files will appear. Log files are date and time stamped and can be downloaded by clicking on the file name link.

Files:
[1975-11-25 07:03:17](#)
[1975-11-25 07:05:52](#)
[1975-11-25 07:08:27](#)
[1975-11-25 07:11:02](#)
[1975-11-25 07:13:38](#)
[1975-11-25 07:16:13](#)
[1975-11-25 07:18:48](#)
[1975-11-25 07:21:23](#)
[1975-11-25 07:21:50](#)

Fuse Replacement - QR

WARNING

HAZARD OF FIRE

Where an internal fuse is to be replaced, the replacement fuse must be of the specified type and current rating. Refer to fuse replacement instructions within the product user manual before servicing.

Failure to follow these instructions can result in death or serious injury.

QR450 Fuse Specification:

Schneider Electric part number: TBUMPWR-FUSE-QR

Specified type fuses are: Littelfuse part numbers 0453007.MR, 0453007.NR, 0453007.MRSN and 0453007.NRSN.

Current rating: 7A

Fuse type: Fast Acting

These fuses can be obtained from the following suppliers.

Supplier	Part Number
Farnell	1677444
Element 14	1677444
Digikey	F3140TR-ND
Mouser	576-0453007.MR
Newark	20C2978

To access the internal fuse of the QR, remove the lid. In order to remove the lid, remove the single 2.5mm hex head screw from underneath the unit.



The fuse in a QR is not soldered into place. Instead it is mounted within a fixed fuse holder.

To replace the fuse, the following instructions should be used.

- Remove the blown fuse. Remove the fuse using a pair of pliers and lifting upwards, as per below diagram.



- Fit the new Fuse. Using a pair of pliers and sit the fuse straight across the top of the fuse holder as per below diagram.

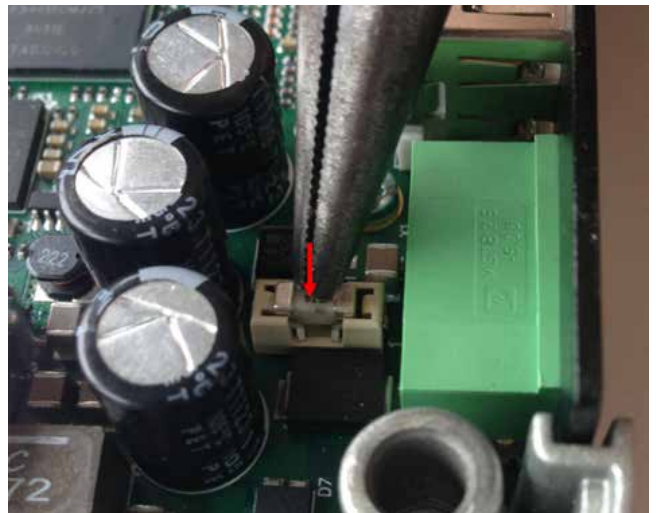

- Then, push down on to the centre of the fuse until it clicks down into place within the fuse holder.



Part K – Open Source License Acknowledgements

CGIC, copyright 1996-2011 by Thomas Boutell and Boutell.Com, Inc. Permission is granted to use CGIC in any application, commercial or noncommercial, at no cost. HOWEVER, this copyright paragraph must appear on a “credits” page accessible in the public online and offline documentation of the program.

Modified versions of the CGIC library should not be distributed without the attachment of a clear statement regarding the author of the modifications, and this notification may in no case be removed.

Modifications may also be submitted to the author for inclusion in the main CGIC distribution.

Component	Version	License	Website
arping	2.09	GPLv2	http://www.habets.pp.se/synscan/programs.php?prog=arping
avahi	0.6.29	LGPL	http://avahi.org/
bash	4.2	GPLv2	https://www.gnu.org/software/bash/
bridge-utils	1.4	GPLv2	http://www.linuxfoundation.org/collaborate/workgroups/networking/bridge
bsdiff	4.3	BSD	http://www.daemonology.net/bsdiff/
busybox	1.20.2	GPLv2	http://www.busybox.net/
bzip2	1.0.6	BSD	http://www.bzip.org/
curl	7.21.7	MIT	http://curl.haxx.se/
dropbear	0.53.1	MIT	https://matt.ucc.asn.au/dropbear/dropbear.html
ethtool	2.6.37	GPLv2	https://www.kernel.org/pub/software/network/ethtool/
expat	2.0.1	BSD	http://expat.sourceforge.net/
gettext	0.16	GPLv2 and LGPLv2+	https://www.gnu.org/software/gettext/
hostapd	0.7.3	GPLv2	http://w1.fi/hostapd/
iptables	1.4.11.1	GPLv2	http://www.netfilter.org/projects/iptables/index.html
libcgic	205	CGIC Basic License	http://www.boutell.com/cgic/
libdaemon	0.14	GPLv2	http://Opointer.de/lennart/projects/libdaemon/
libffi	3.0.9	BSD	https://sourceware.org/libffi/
libiconv	1.13.1	LGPL	https://www.gnu.org/software/libiconv/
libnet	1.1.2.1	BSD	http://libnet.sourceforge.net/
lighttpd	1.4.29	BSD	http://www.lighttpd.net/
Linux Kernel	2.6.38	GPLv2	https://www.kernel.org/
lzo	2.05	GPLv2	http://www.oberhumer.com/opensource/lzo/
makepasswd	0.5.1	GPL	https://github.com/khorben/makepasswd
net-snmp	5.7.1	BSD	http://www.net-snmp.org/
ncurses	5.9	MIT	https://www.gnu.org/software/ncurses/
ntp	4.2.8	MIT/BSD	http://www.ntp.org/
openssl	0.9.8za	OpenSSL	https://www.openssl.org/
pcre	8.13	BSD	http://www.pcre.org/
python	2.7.2	PSF	https://www.python.org/
pyserial	2.5	PSF	http://pyserial.sourceforge.net/
socat	1.7.1.3	GPLv2	http://www.dest-unreach.org/socat/
u-boot	2011-12	GPLv2+	http://www.denx.de/wiki/U-Boot/WebHome
uClibc	0.9.31	LGPL	http://www.uclibc.org/
wpa_supplicant	0.6.10	GPLv2	http://w1.fi/wpa_supplicant/
zlib	1.2.5	BSD	http://www.zlib.net/

Part L – Support Options

When e-mailing questions to our support staff, make sure you tell us the exact model number (and serial number if possible) of the Trio equipment you are working with. Include as much detail as possible about the situation including radio configuration files and system diagrams, also any tests that you have done which may help us to better understand the issue. If possible, include your telephone contact information should we wish to further clarify any issues.

Technical Support: The Americas, Europe, Middle East, Asia

Available Monday to Friday 8:00am - 6:30pm Eastern Time
Toll free within North America: 1-888-226-6876
Direct Worldwide: +1-613-591-1943
Email: SupportTRSS@schneider-electric.com

Technical Support: Australia

Inside Australia: 1 300 369 233
Email: au.help@schneider-electric.com

Manufactured by Trio Datacom Pty Ltd
(a wholly owned company
of Schneider Electric)
415 Legget Drive, Suite 101,
Kanata, Ontario, K2K 3R1, Canada
Printed in Canada