

## BATTERY INSTALLATION

### PERFORMANCE TIPS

1. Operate your vehicle in a safe place. Do not drive in the street. Avoid driving through sand, mud, and water, which can impair the performance of your vehicle.
2. Do not leave your vehicle near sources of heat or under direct sunlight for long periods of time.
3. Do not expose your transmitter or car to humidity for long periods of time as dampness can damage interior mechanism.
4. Clean the toy vehicle regularly with a slightly damp cloth.
5. When the vehicle slows down or begins to move erratically, replace the batteries with new ones.
6. Concrete walls, metal posts, wire fence, and other electrical appliances and machineries can interfere with the transmission signal of your transmitter and result in erratic performance of your car. In this case, change to a different location.
7. If another radio control vehicle or CB radio is operating at your same location, they may interfere with the performance of your vehicle.
8. Alkaline batteries are highly recommended.

### BATTERY CAUTIONS

1. For maximum performance, use alkaline batteries.
2. Do not mix old and new batteries.
3. Do not mix alkaline, standard (carbon-zinc), or rechargeable batteries.
4. Do not recharge non-rechargeable battery.
5. Ensure batteries are inserted with the correct polarity.
6. Remove batteries when toy is not in use.
7. Remove exhausted batteries from toy and dispose of in accordance with the makers recommendation.
8. Rechargeable batteries should only be charged under adult supervision.
9. Remove rechargeable batteries from toy before charging.
10. The supply terminals are not to be short-circuited.

Battery/Batteries should be installed by adult only. The toy is not intended for children under 3 years old.  
Keep packing for reference since it contains important information.  
Exhausted batteries are to be removed from the toy.

### WARNING:

NOT SUITABLE FOR CHILDREN UNDER THE AGE OF 36 MONTHS AS SMALL PART(S) AND ENTANGLEMENT/STRANGULATION HAZARDS. PACKAGING MATERIALS ARE NOT TOYS. PLEASE REMOVE ALL PACKAGING AND PACKING TAGS/WIRES BEFORE GIVING THIS TOY TO YOUR CHILD. COLOUR, DESIGNS AND DECORATIONS MAY VARY FROM THOSE SHOWN IN THE PHOTOGRAPHS. HAIR ENTANGLEMENT MAY RESULT IF THE CHILD'S HEAD IS TOO CLOSE TO THE MOTORISED UNIT OF THIS TOY.

### ATTENTION PARENTS

It is recommended that this toy and all accessories be periodically examined for potential hazards and that any potentially hazardous parts be repaired or replaced.

### HOW TO INSTALL BATTERY IN VEHICLE

1. Turn over the vehicle and push the ON/OFF to "OFF" position. (See Diagram #1)
2. Open the battery cover. (See Diagram #1)
3. Follow the "arrow" sign and insert the battery pack into the battery compartment. Make sure the (+) (-) polarity is correct. (See Diagram #2)
4. Replace the battery cover.

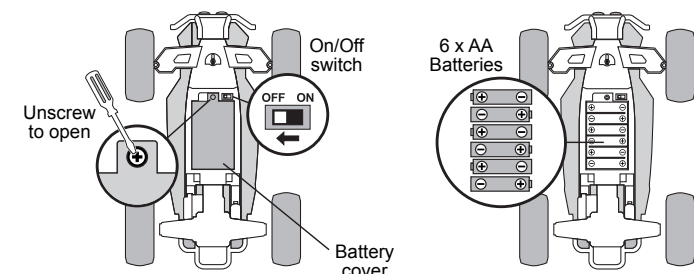

DIAGRAM 1

DIAGRAM 2

### HOW TO INSTALL BATTERY IN TRANSMITTER

1. Remove battery cover and install 2 x AA batteries by matching + and - poles as indicated in the battery compartment. (See Diagram #3)
2. Replace the battery cover.

**Note:** Remove battery after you have finished using your vehicle.

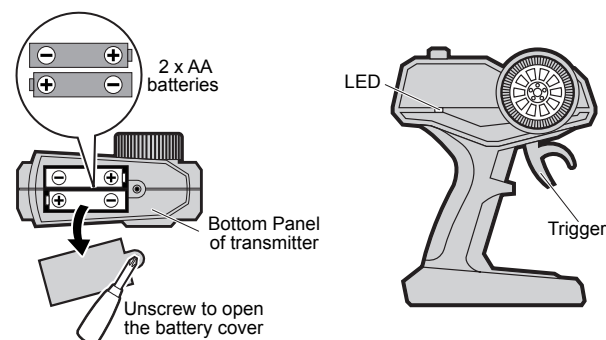

DIAGRAM 3

DIAGRAM 4

### HOW TO PLAY PAIRING TRANSMITTER WITH VEHICLE

1. Turn ON the vehicle (See Diagram #5).
2. Install 2 x AA battery in the transmitter, the pairing LED light on the transmitter will flash (See Diagram #3).
3. If pairing success, the pairing LED light will turn OFF.
4. You must pairing the transmitter with the vehicle within 45 seconds, after 45 seconds you must push the control on the transmitter to pair again.
5. You must repeat pairing again when the transmitter needs to replace new batteries.

### Notes:

1. If pairing failed, reinstall the battery of transmitter, move closer and then try again.
2. If more than one vehicle are pairing at the same time, pair each vehicle one by one.

Vehicle has memory to store the paired data, no need to pair each time play until replace the battery in transmitter

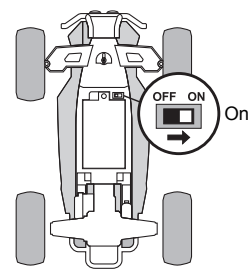

DIAGRAM 5

### OPERATION

1. Operate the vehicle with the transmitter (See Diagram #6).
2. Turn OFF the vehicle after playing and remove all batteries from the transmitter and the car.

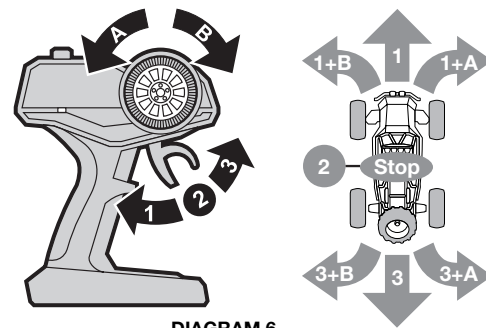

DIAGRAM 6

3. To adjust steering alignment, adjust the "Steering Alignment Lever" on the underside of the vehicle when the vehicle does not run straight forward (See Diagram #7).

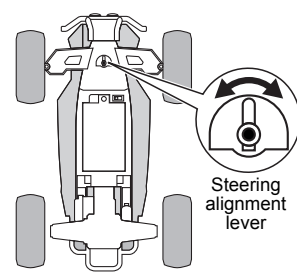

DIAGRAM 7

### CAUTIONS

1. Non-rechargeable batteries are not to be recharged.
2. Rechargeable batteries are to be removed from the toy before being charged.
3. Rechargeable batteries are only to be charged under adult supervision.
4. Different types of batteries or new and used batteries are not to be mixed.
5. Only batteries of the same or equivalent type as recommended are to be used.
6. Batteries are to be inserted with the correct polarity.
7. Exhausted batteries are to be removed from the toy.
8. The supply terminals are not to be short-circuited.

WARNING: CHOKING HAZARD - SMALL PARTS, NOT FOR CHILDREN UNDER 3 YEARS.

### FCC INFORMATION

This equipment has been tested and found to comply with the limits for a Class B digital device, pursuant to Part 15 of the FCC Rules. These limits are designed to provide reasonable protection against harmful interference in a residential installation. This equipment generates, uses and can radiate radio frequency energy and, if not installed and used in accordance with the instructions, may cause harmful interference to radio communications. However, there is no guarantee that interference will not occur in a particular installation. If this equipment does cause harmful interference to radio or television reception, which can be determined by turning the equipment off and on, the user is encouraged to try to correct the interference by one or more of the following measures:

- Reorient or relocate the receiving antenna.
- Increase the separation between the equipment and receiver.
- Connect the equipment into an outlet on a circuit different from that to which the receiver is connected.
- Consult the dealer or an experienced radio/TV technician for help.

If you cannot eliminate the interference, the FCC requires that you stop using your equipment. Changes or modifications not expressly approved by the party responsible for compliance could void the user's authority to operate the equipment. This device complies with Part 15 of the FCC rules. Operation is subject to the following two conditions:

- (1) this device may not cause harmful interference, and
- (2) this device must accept any interference received, including interference that may cause undesired operation.



**WARNING:**  
**CHOKING HAZARD-**  
Small parts, Not for children under 3 years

**EZTEC**<sup>®</sup>  
www.eztec.hk

EZ-TEC<sup>®</sup> IS A REGISTERED TRADEMARK OWNED BY SCIENTIFIC TOYS, LTD.  
© 2017 SCIENTIFIC TOYS LTD. 1108, TOWER B,  
14 SCIENCE MUSEUM ROAD, TSIMSHATSUI, HONG KONG.  
PRINTED IN CHINA  
O.I. NO.6102

SIZE: 210MM X 297MM PN#65-6102-000-0100