

SEGA™

GAME GEAR™

COLOR PORTABLE VIDEO GAME SYSTEM

MAINTENANCE MANUAL

EUROPE

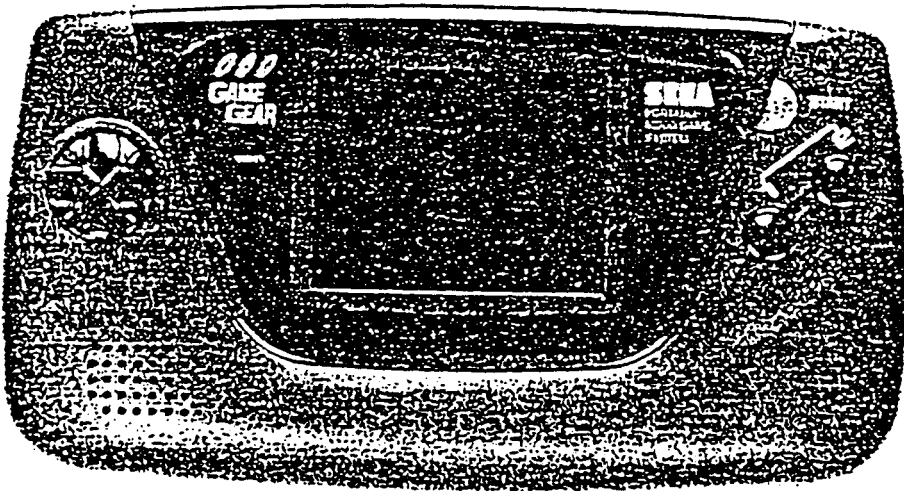

August, 1992
SEGA ENTERPRISES, LTD.
Rev. A

GAME GEAR
MAINTENANCE MANUAL
EUROPE

◆ INDEX ◆

1. BLOCK DIAGRAM
2. ASSEMBLY DRAWING
- 2-1. GENERAL REFERENCE NUMBER LIST
- 2-2. ASSEMBLY LIST
 - 1001 BOTTOM CASE ASSEMBLY 1
 - 1002 BOTTOM CASE ASSEMBLY 2
 - 1003 MAIN BOARD ASSEMBLY
 - 1004 BOTTOM CASE ASSEMBLY 3
- 2-3. PROCEDURE OF DISASSEMBLY AND ASSEMBLY
3. SPARE PARTS LIST
4. ACCESSORIES LIST
5. PCB REPAIR PROCEDURE
6. SOFT & HARD CHECK MANUAL

7. PARTS SPECIFICATION

7-1.	MAIN BOARD	IC1	IC	Z80A	TMP84C00AM-6
7-2.	MAIN BOARD	IC2	IC	CUSTAM	VDP 315-5377
7-3.	MAIN BOARD	IC3	IC	CUSTAM	SCA 315-5378A
7-4.	MAIN BOARD	IC4	IC	μ PD4364G-15L	
7-5.	MAIN BOARD	IC5	IC	HM6256BLFP-12	
7-6.	MAIN BOARD	IC6	IC	μ PC358G2	
7-7.	DC-DC CONV. BOARD	IC1	IC	MB3775FP-G-BND	
7-8.	SOUND BOARD	IC1	IC	TDA2822M	

8. PARTS LIST OF PCB

8-1.	IC	BD	GG	MAIN	EUROPE
8-2.	IC	BD	GG	MAIN	EUROPE B
8-3.	IC	BD	GG	DC-DC CONV.	EUEOPE
8-4.	IC	BD	GG	DC-DC CONV.	EUEOPE B
8-5.	IC	BD	GG	SOUND	EUROPE
8-6.	IC	BD	GG	SOUND	EUROPE B

9. SCHEMATIC DIAGRAM

9-1.	PC	BD	GG	MAIN	EUROPE
9-2.	PC	BD	GG	MAIN	EUROPE SCA B
9-3.	PC	BD	GG	DC-DC CONV.	EUROPE
9-4.	PC	BD	GG	DC-DC CONV.	EUROPE SCA B
9-5.	PC	BD	GG	SOUND	EUROPE
9-6.	PC	BD	GG	SOUND	EUROPE SCA B

10. MOUNT DIAGRAM

10-1a.	IC	BD	GG	MAIN	EUROPE	Comp	Side
10-1b.	IC	BD	GG	MAIN	EUROPE	Sold	Side
10-2a.	IC	BD	GG	MAIN	EUROPE	SCA B	Comp Side
10-2b.	IC	BD	GG	MAIN	EUROPE	SCA B	Sold Side
10-3a.	IC	BD	GG	DC-DC CONV.	EUROPE		
10-3b.	IC	BD	GG	DC-DC CONV.	EUROPE	SCA B	
10-4a.	IC	BD	GG	SOUND	EUROPE		
10-4b.	IC	BD	GG	SOUND	EUROPE	SCA B	

GAME GEAR

EUROPE

B L O C K D I A G R A M

GameGear ブロック図...

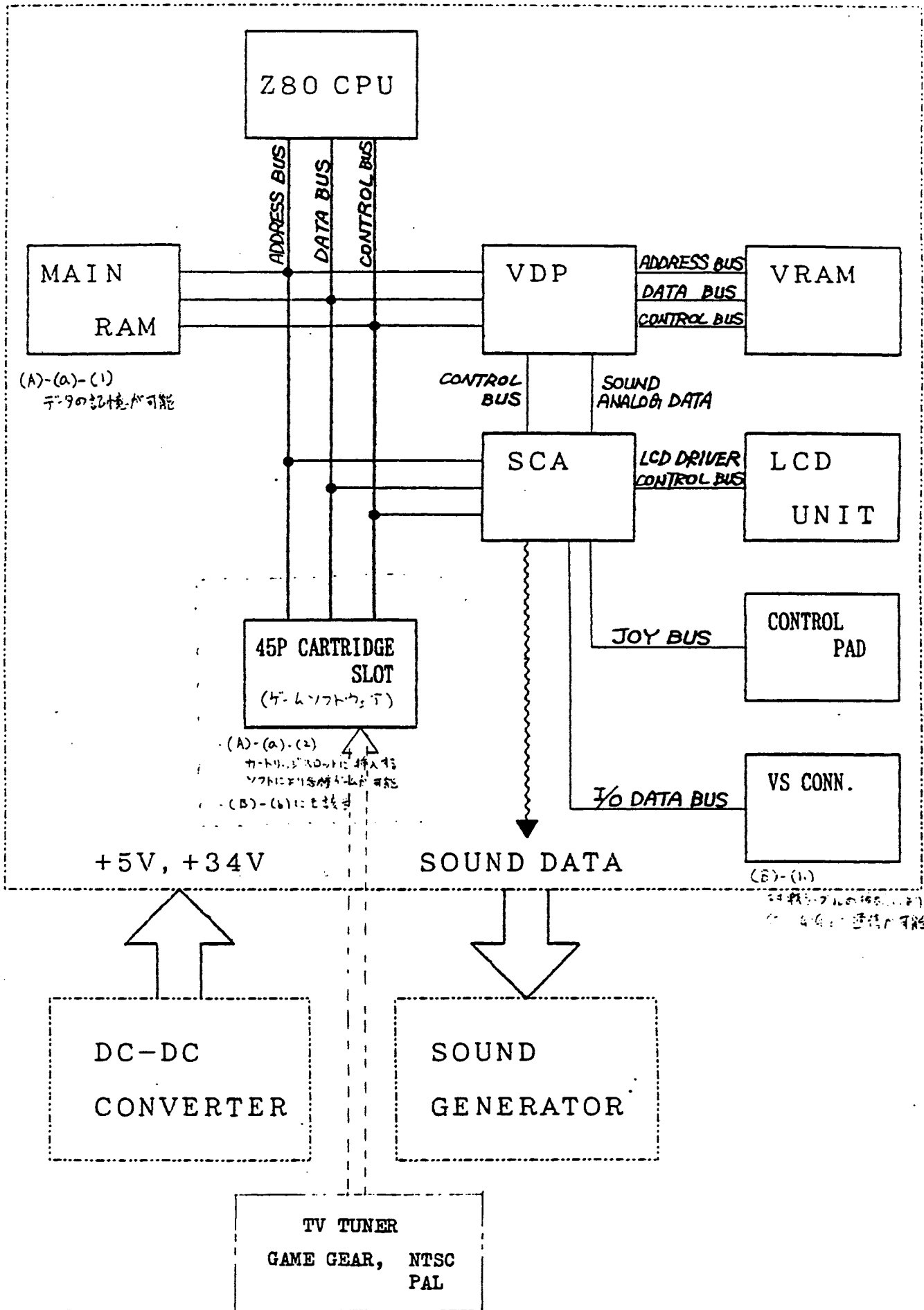

11. PCB DESIGN SPEC.

11-1a.	PC	BD	GG	MAIN BOARD	COMP SIDE MARK
11-1b.	PC	BD	GG	MAIN BOARD	SOLD SIDE MARK
11-1c.	PC	BD	GG	MAIN BOARD	COMP SIDE LAYER
11-1d.	PC	BD	GG	MAIN BOARD	SOLD SIDE LAYER
11-2a.	PC	BD	GG	DC-DC CONV. BOARD	COMP SIDE MARK
11-2b.	PC	BD	GG	DC-DC CONV. BOARD	SOLD SIDE MARK
11-2c.	PC	BD	GG	DC-DC CONV. BOARD	COMP SIDE LAYER
11-2d.	PC	BD	GG	DC-DC CONV. BOARD	SOLD SIDE LAYER
11-3a.	PC	BD	GG	SOUND BOARD	COMP SIDE MARK
11-3b.	PC	BD	GG	SOUND BOARD	SOLD SIDE MARK
11-3c.	PC	BD	GG	SOUND BOARD	COMP SIDE LAYER
11-3d.	PC	BD	GG	SOUND BOARD	SOLD SIDE LAYER

GAME GEAR FOR EUROPE

GENERAL REFERENCE NUMBER LIST

REF NO.	PART NO.	DESCRIPTION	QTY
001	610-5212	ASSY TOP CASE GG USA	(1)
	610-5212-01	ASSY TOP CASE GG USA 01	(1)
002	610-5255	ASSY BOTTOM CASE GG MULTI	(1)
	610-5255-01	ASSY BOTTOM CASE GG MULTI 01	(1)
003	253-6362	CLEAR PLATE GG	(1)
	253-6434	CLEAR PLATE GG INMOLD	(1)
004	253-6363-01	PAD GG 01	(1)
	253-6363-03	PAD GG 03 (CONTACT TYPE)	(1)
005	253-6364	BUTTON 1 GG	1
006	253-6365	BUTTON 2 GG	1
007	253-6366	START BUTTON GG	1
008	253-6368	BATT LID LEFT GG	1
009	253-6369	BATT LID LIGHT GG	1
010	253-6378	POWER KNOB GG	1
011	253-6401	10P CONN COVER GG	1
101	837-7994	ASSY IC BD GG EUROPE	(1)
	837-7994B	ASSY IC BD GG EUROPE B	(1)
102	837-7997	IC BD GG DC-DC CONV.EUROPE	(1)
	837-7997B	IC BD GG DC-DC CONV.EUROPE B	(1)
103	837-7998	IC BD GG SOUND EUROPE	(1)
	837-7998B	IC BD GG SOUND EUROPE B	(1)
201	029-0069	TAP SCR PH 2.6*10 BLK	6
202	012-0312	TAP SCR PH 3*12	2
203	012-0206	TAP SCR PH 2*6	10
204	029-0326	TAP SCR LH-3 2.6*10 BLK	1
301	509-5334	RUBBER CONTACT GG 4P	(1)
	509-5334-01	RUBBER CONTACT GG 4P 01	(1)
302	509-5335	RUBBER CONTACT GG 1P	3
303	601-6428	LCD CUSHION GG	1
304	253-6422	BATT. BLADE COVER GG	1
305	250-6243	SUPPORT PLATE GG 01	1

GAME GEAR

EUROPE

ASSEMBLY DRAWING

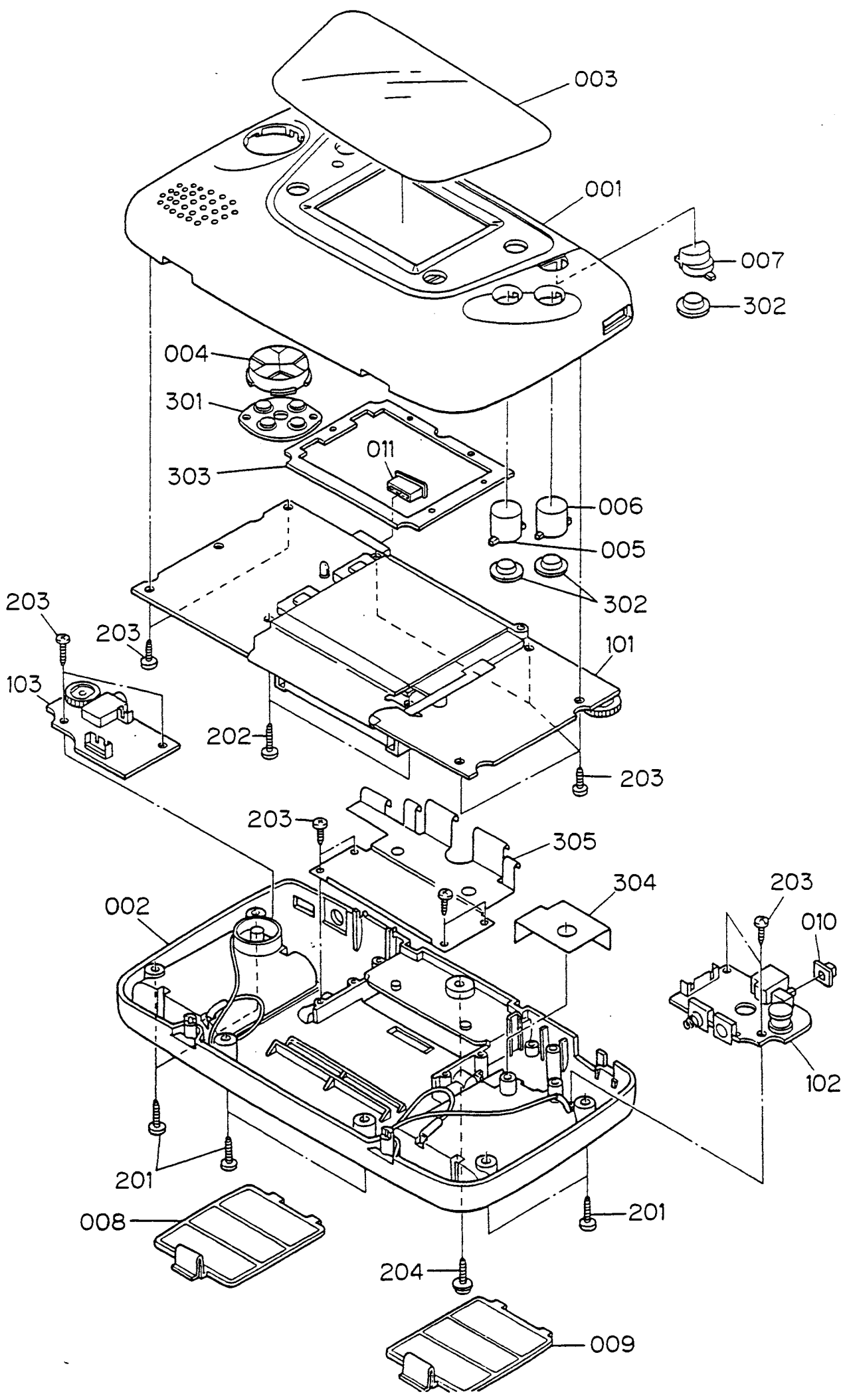

ASSEMBLY LIST FOR GAME GEAR EUROPE

INDEX

- 1001 BOTTOM CASE ASSEMBLY 1
- 1002 BOTTOM CASE ASSEMBLY 2
- 1003 MAIN BOARD ASSEMBLY
- 1004 BOTTOM CASE ASSEMBLY 3

PARTS LIST FOR GAME GEAR EUROPE

1001 BOTTOM CASE ASSEMBLY 1

REF NO.	PART NO.	DESCRIPTION	QTY
008	253-6368	BATT LID LEFT GG	1
009	253-6369	BATT LID LIGHT GG	1
201	029-0069	TAP SCR PH 2.6*10 BLK	6
204	029-0326	TAP SCR LH-3 2.6*10 BLK	1

1001 BOTTOM CASE ASSEMBLY 1

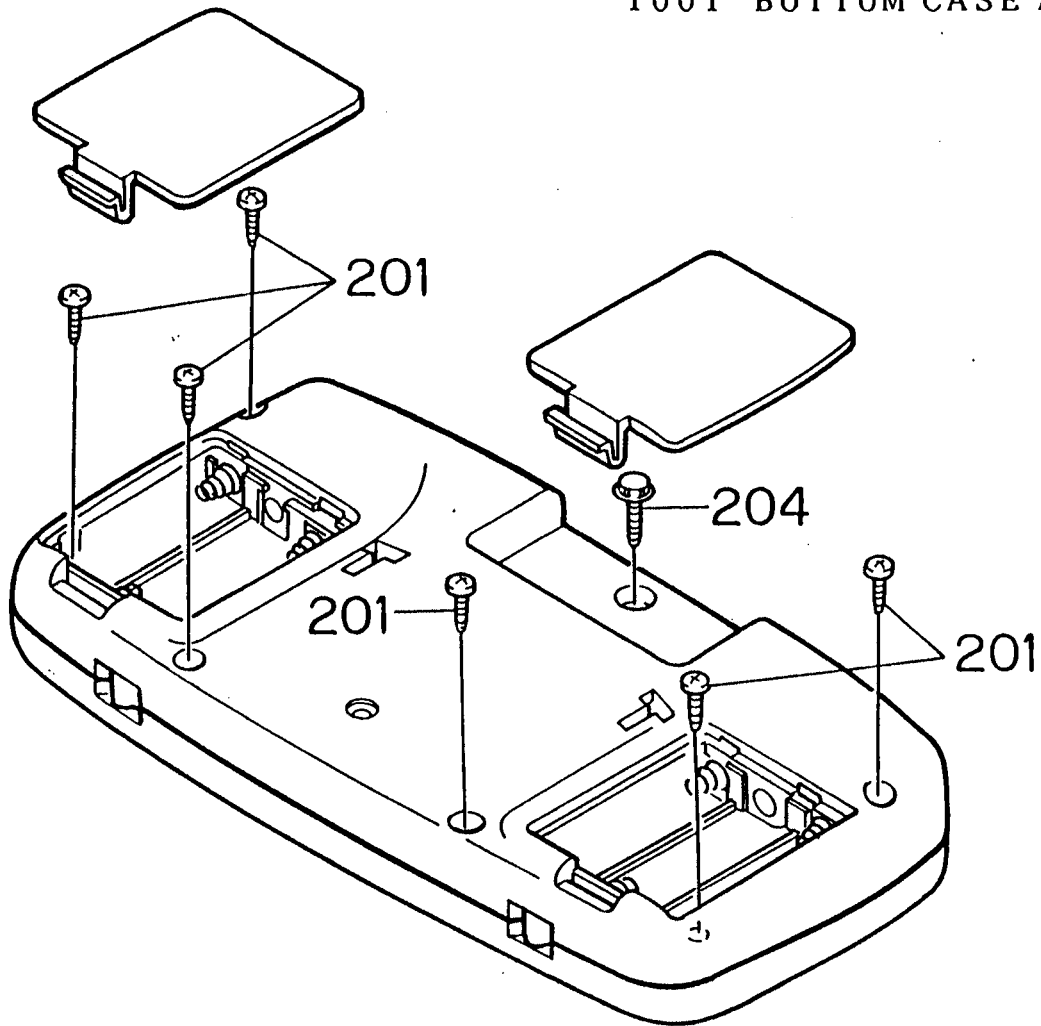

PARTS LIST FOR GAME GEAR EUROPE

1002 BOTTOM CASE ASSEMBLY 2

REF NO. PART NO. DESCRIPTION QTY

NON PARTS ASSEMBLY.

1002 BOTTOM CASE ASSEMBLY

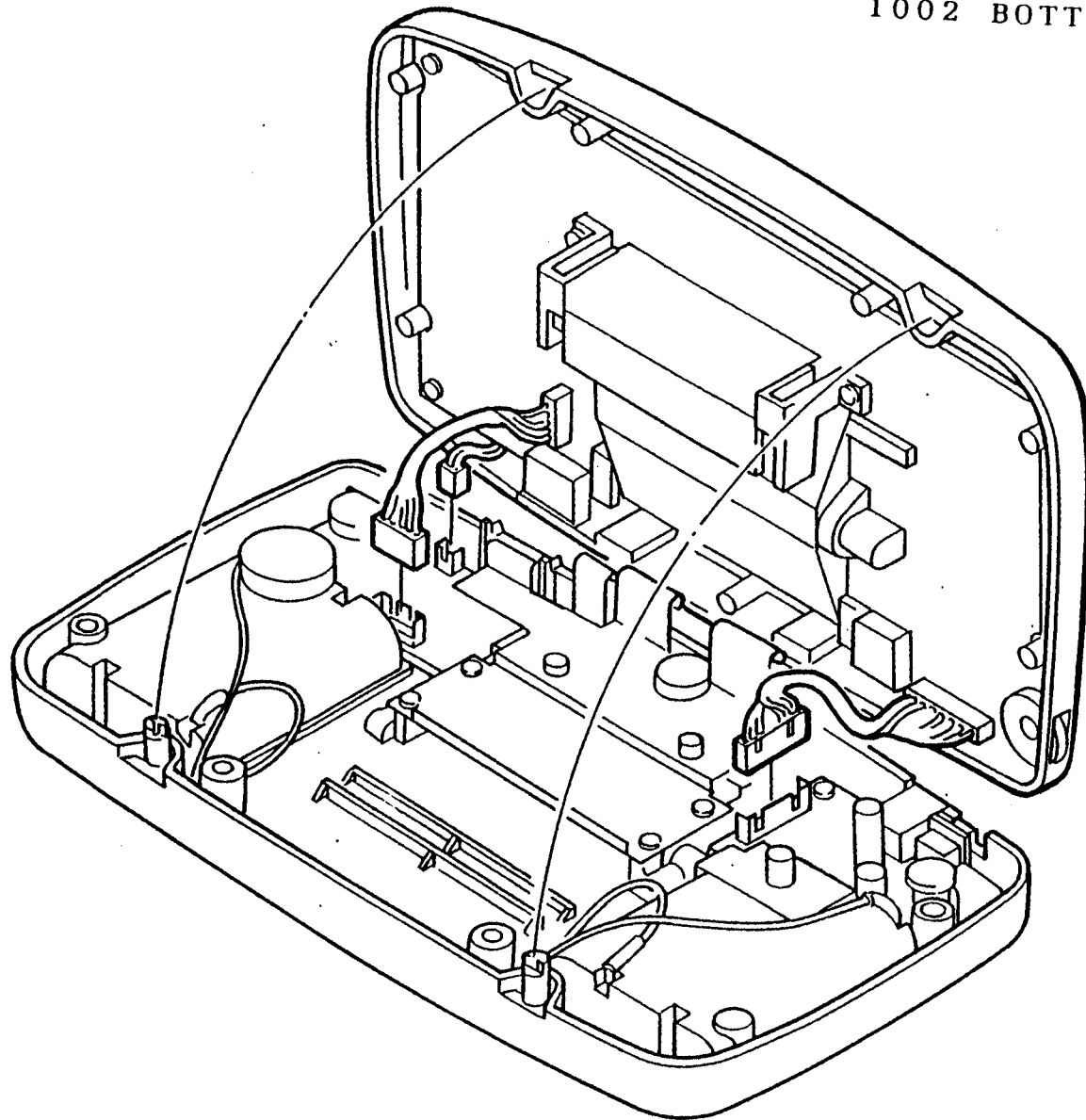

PARTS LIST FOR GAME GEAR EUROPE

1003 MAIN BOARD ASSEMBLY

REF NO.	PART NO.	DESCRIPTION	QTY
101	837-7994	ASSY IC BD GG EUROPE	(1)
	837-7994B	ASSY IC BD GG EUROPE B	(1)
202	012-0312	TAP SCR PH 3*12	2
203	012-0206	TAP SCR PH 2*6	6

1003 MAIN BOARD ASSEMBLY

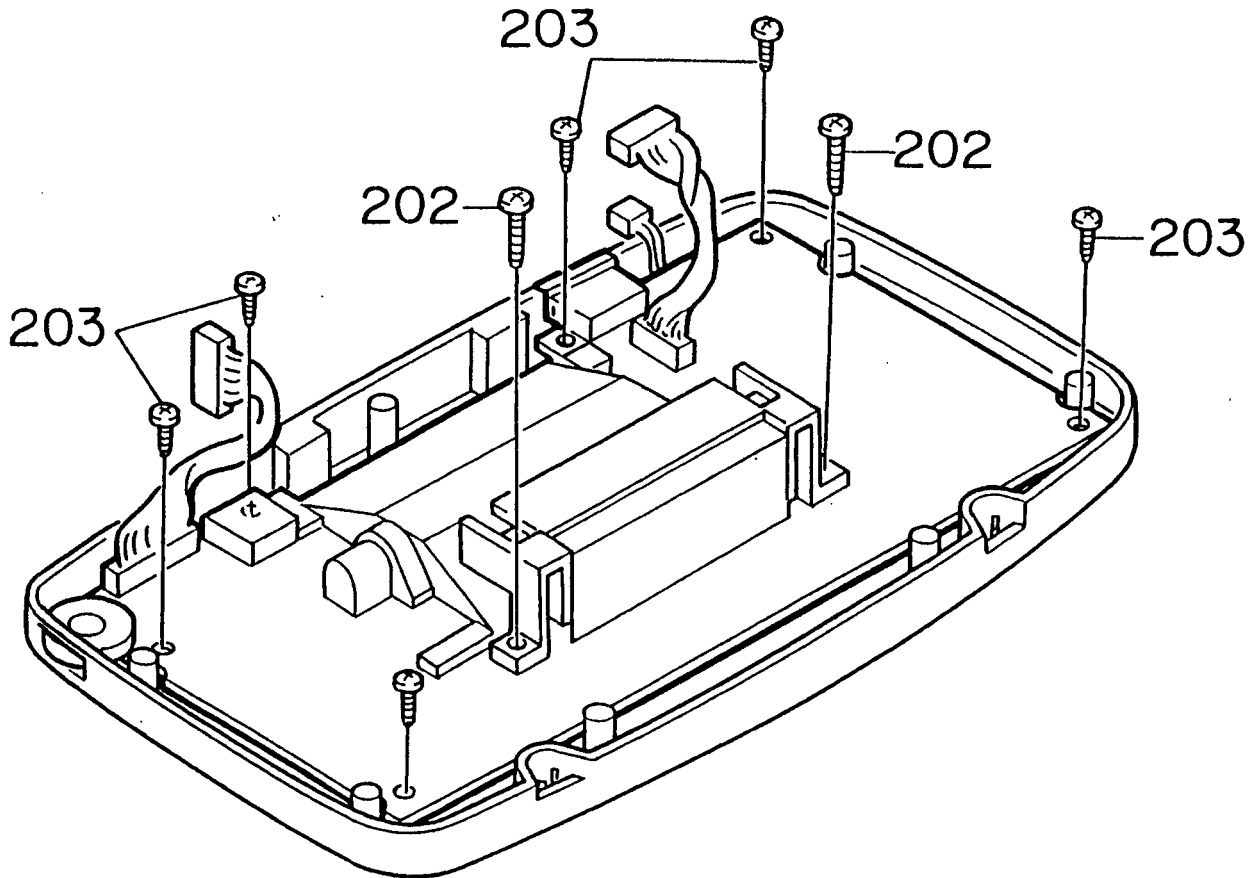

PARTS LIST FOR GAME GEAR EUROPE

1004 BOTTOM CASE ASSEMBLY 3

REF NO.	PART NO.	DESCRIPTION	QTY
002	610-5255	ASSY BOTTOM CASE GG MULTI	(1)
	610-5255-01	ASSY BOTTOM CASE GG MULTI 01	(1)
102	837-7997	IC BD GG DC-DC CONV.EUROPE	(1)
	837-7997B	IC BD GG DC-DC CONV.EUROPE B	(1)
103	837-7998	IC BD GG SOUND EUROPE	(1)
	837-7998B	IC BD GG SOUND EUROPE B	(1)
203	012-0206	TAP SCR PH 2*6	8
305	250-6243	SUPPORT PLATE GG 01	1

1004 BOTTOM CASE ASSEMBLY 3

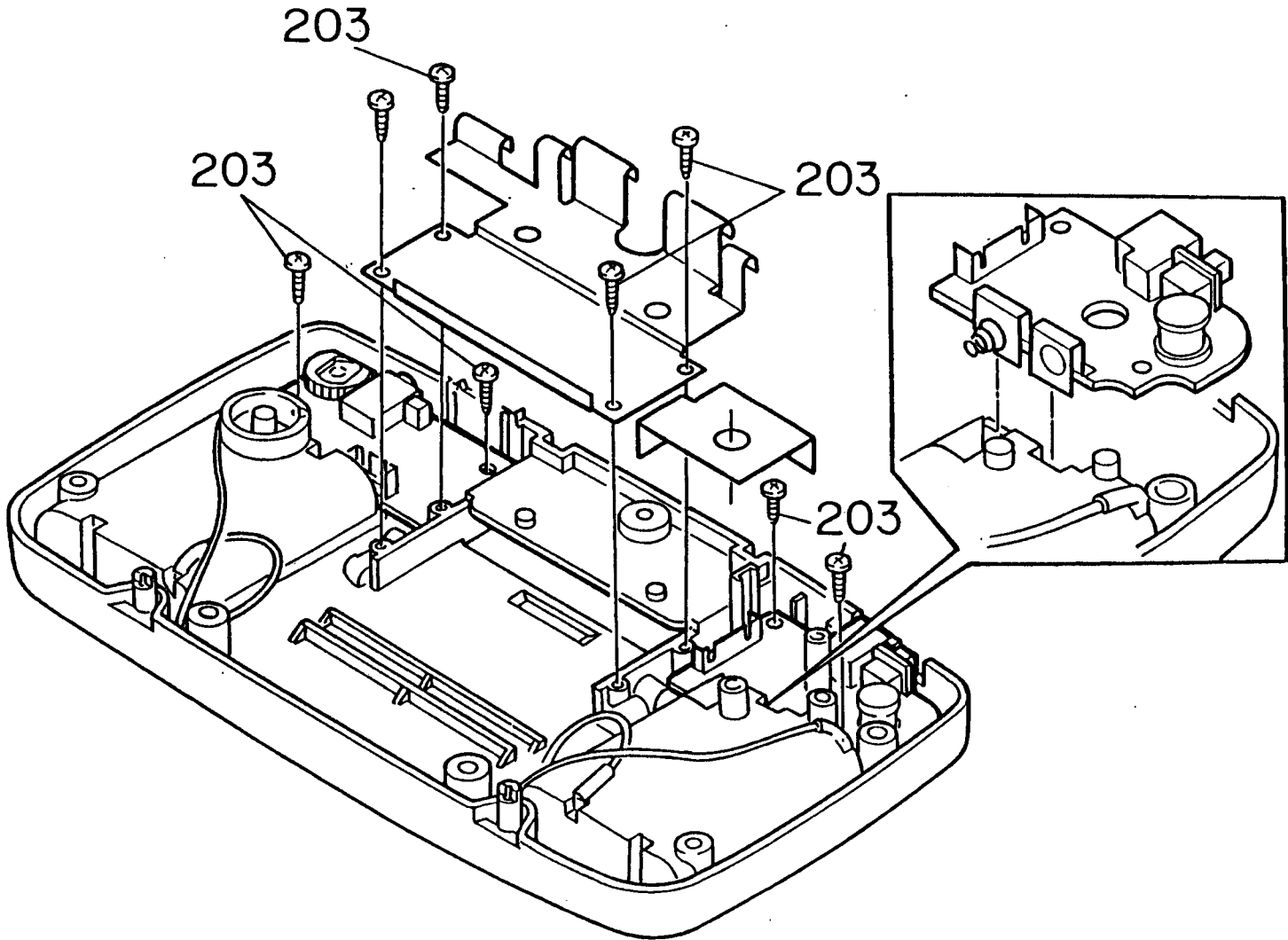

PROCEDURE OF DISASSEMBLY AND ASSEMBLY OF GAME GEAR

1. DISASSEMBLY

PROCESS 1 : Removing screw from Bottom Case.

- 1) Upset the unit.
- 2) Remove Battery Lid.
- 3) Remove screws (201 and 204)
- 4) Remove a screw (204)

PROCESS 2 : Removing Bottom Case.

- 1) Hold up Bottom Case to the direction (A) and make the open condition.
- 2) Remove the connector of DC converter Board fixed on the Bottom Case.
- 3) Remove two connectors of Sound Board fixed as above.

PROCESS 3 : Removing the Main Board.

- 1) Remove the screws (two 202 and six 203) and Main Board from Top Case.

PROCESS 4 : Removing Support Plate, DC-DC Conv. Board and Sound Board.

- 1) Remove 4 screws (203).
- 2) Remove Support Plate from Bottom Case.
- 3) Remove 2 screws (203).
- 4) Remove DC-DC Conv. Board from Bottom Case.
- 5) Remove 2 screw (203).
- 6) Remove Sound Board as above.

2. ASSEMBLY

PROCESS 1 : Setting Support Plate, DC-DC Conv. Board and Sound Board.

- 1) Set the Sound Board, DC-DC Conv. Board and Support Plate to Bottom Case using 8 screws (203).

PROCESS 2 : Setting of Main Board.

- 1) Spray surface of inside clear plate with static proof liquid.
- 2) Carefully observe and take away dust inside clear plate and Top Case using air gun in clean place. Set each Button and Rubber contact to normal position.
- 3) Set LCD cushion along to the place of Bosses in Top Case.
- 4) Lead Speaker Cable outside of Boss of Top Case.
- 5) Setting of Main Board.
 - Case 1 After exchange of LCD
Take off protection film of LCD.
 - Case 2 Others
Clean surface of LCD using air gun.Set the Main Board inside and along to the Bosses of Top Case.

- Note : At the setting of Main Board, it is important to set it as quick as possible to prevent the stick of dust on the surface of LCD and clear plate.
- 6) Fix screw 6 of 203 and 2 of 202.

PROCESS 3 : Setting of Bottom Case.

- 1) Correct 2 connectors from Main Board to Sound Board and 1 connector from Main Board to DC-DC Conv. Board.
- 2) Firmly set Bottom Case to Top Case taking care not to pinch cables in the edge of cases.

PROCESS 4 : Screwing Bottom Case.

- 1) Upset the unit.
- 2) Fix a screw (204).
- 3) Fix 6 screws (201).
- 4) Fix Battery Lids.

GAME GEAR

EUROPE

SPARE PARTS LISTS

GAME GEAR SPARE PARTS LIST FOR EUROPE

No	PARTS No.	DESCRIPTION	R1	R2	R3	R4
1	610-5212	Assy Top Case GG USA	●		●	
	610-5212-01	Assy Top Case GG USA 01		●		●
2	610-5255	Assy Bottom Case GG MULTI	●		●	
	610-5255-01	Assy Bottom Case GG MULTI 01		●		●
3	253-6362	CLEAR PLATE GG	●	●		
	253-6434	CLEAR PLATE GG INMOLD	●	●	●	●
4	509-5334-01	RUBBE CONTACT 4P 01	●	●		
	509-5334	RUBBER CONTACT 4P			●	●
	509-5335	RUBBER CONTACT 1P	●	●	●	●
5	837-7994	ASSY IC BD GG EUROPE (837-7995)	●	●	●	●
	837-7994B	ASSY IC BD GG EUROPE (837-7995B SCA B)	●	●	●	●
6	837-7997	IC BD GG DC-DC CONV.EUROPE	●	●	●	●
7	837-7998	IC BD GG SOUND EUROPE	●	●	●	●

Note:

R1: PARTS No.610-5224 ASSY GG MULTI
R2: PARTS No.610-5224-01 ASSY GG MULTI 01
R3: PARTS No.610-5358 ASSY GG MULTI CONTACT TYPE
R4: PARTS No.610-5358-01 ASSY GG MULTI CONTACT TYPE 01

GAME GEAR

EUROPE

ACCESSORIES LIST

GAME GEAR ACCESSORIES LIST FOR EUROPE

No	PARTS No.	DESCRIPTION
1	MK-2101-05	TV TUNER PAC (PAL-I:ENGLAND)
	MK-2101-18	TV TUNER PAC (PAL-B:ITALY/PAL-G:GERMANY)*ZZF APPROVAL
	MK-2101-20	TV TUNER PAC (PAL-B:ITALY/PAL-G:GERMANY)*ZZF NOT APPROVAL
2	MK-2102-50	GEAR TO GEAR CABLE
3	MK-2104-50	CAR ADAPTOR
4	MK-2105-50	BATTERY PAC
5	MK-2106-50	AV CABLE
6	400-5122A	AC ADAPTOR AC220V/DC10V 1.2A
	400-5122B	AC ADAPTOR AC220V/DC10V 1.2A
	400-5127	AC ADAPTOR AC240V/DC10V 1.2A
	400-5127A	AC ADAPTOR AC240V/DC10V 1.2A

GAME GEAR

EUROPE

P C B R E P A I R P R O C E D U R E

PCB REPAIR FLOW CHART

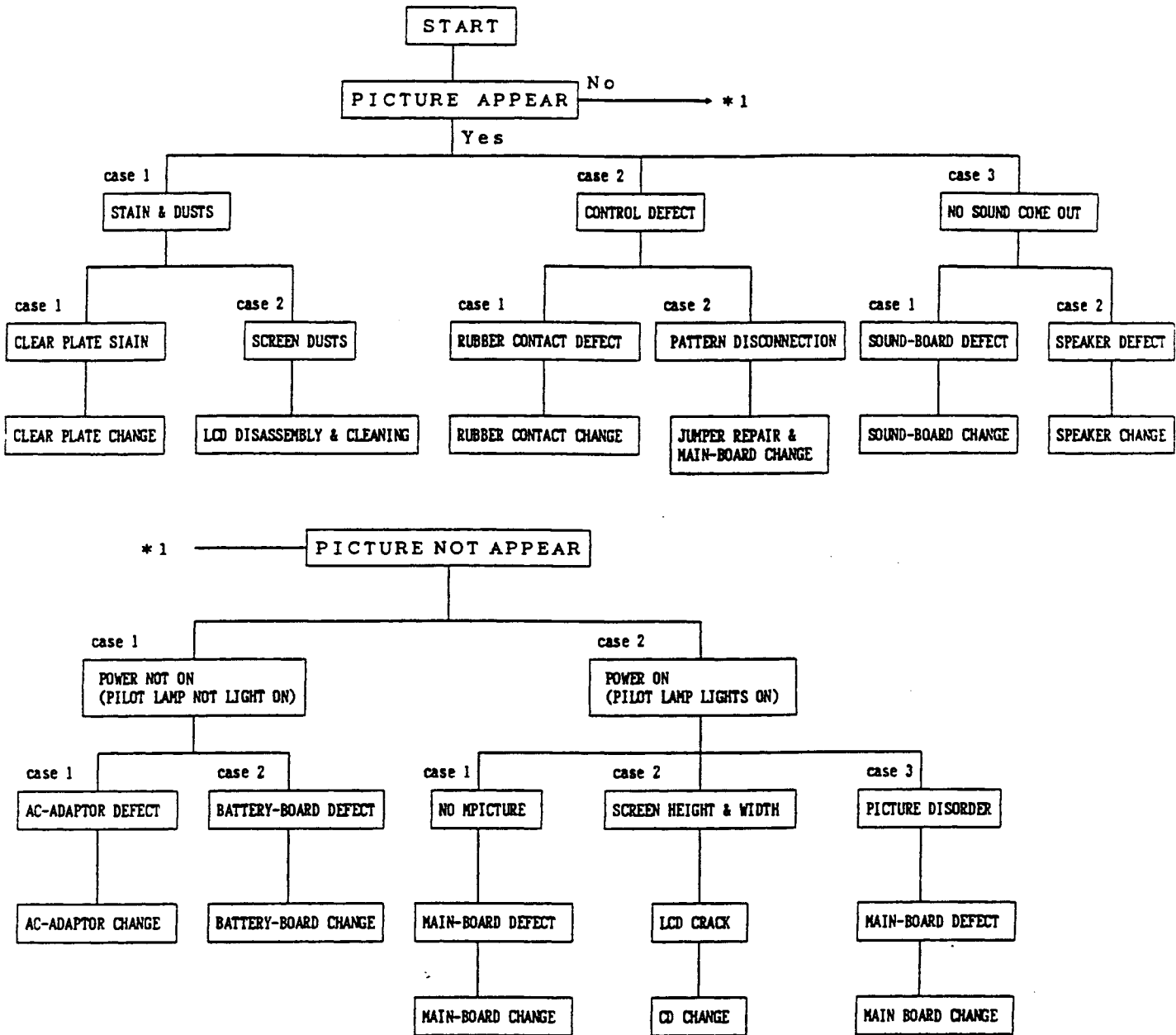

GAME GEAR

EUROPE

SOFT & HARD CHECK MANUAL

SOFT CHECK MANUAL

GAME GEAR SOFT CHECK FLOW

CHECK CARTRIDGE-----

COMMUNICATION CABLE |---> START

HEADPHONE-----



NO

CHECK PATTERNS APPEAR ---> ERROR

|Yes



NO

CHECK OF 4-KEY PAD & BUTTON 1 OR 2 & HEADPHONE SOUND ---> ERROR

|Yes



REMOVE THE HEADPHONE PIN



NO

CHECK OF THE BUILT-IN SPEAKER ---> ERROR

|Yes



START BUTTON ON



NO

-----> CHECK OF BRIGHTNESS (CONTRAST) ---> ERROR

|Yes



START BUTTON ON



NO

CHECK COLOR 1 (VERTICAL COLOR PATTERNS) ---> ERROR

|Yes



START BUTTON ON



NO

CHECK COLOR 2 (HORIZONTAL COLOR PATTERNS) ---> ERROR

|Yes



-----> START BUTTON ON



END

GAME GEAR SOFT CHECK MANUAL

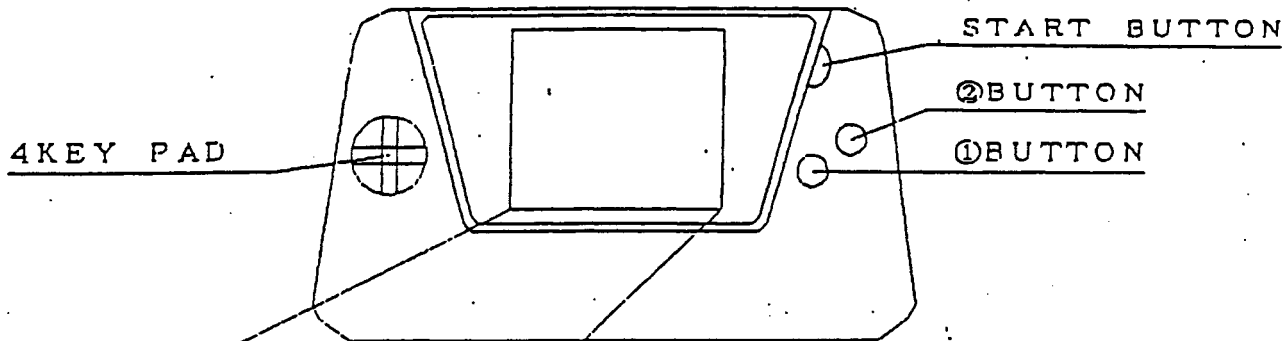
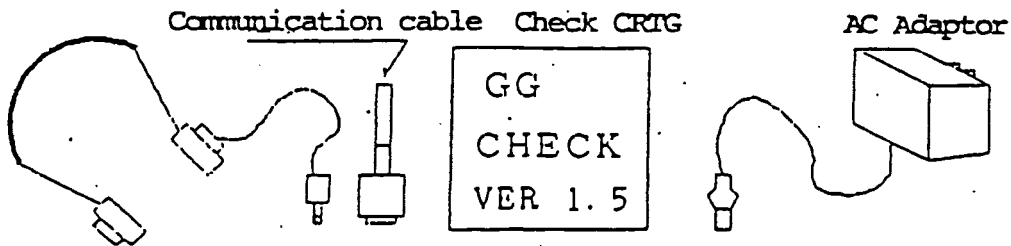

SCREEN 1

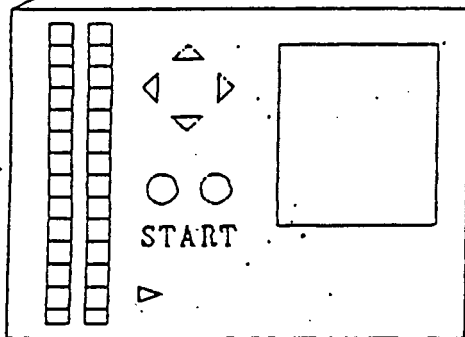

If the power is turned on, the screen shown on left is displayed.
 Make sure that the LED location is correct and the LED is lit.
 Be sure that the mark ▶ under START moves in the right direction.

Check 1. Check of 4-key pad & headphone sound

Press button-1 while pressing an optional direction of the 4-key pad ; then, the sound is heard from the left of the headphone.
 In the same manner, press button-2 ; then, the sound is heard from the right of the headphone.

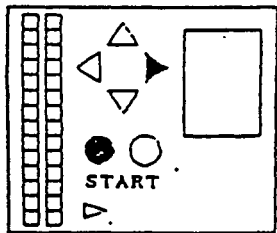

Right + ① button

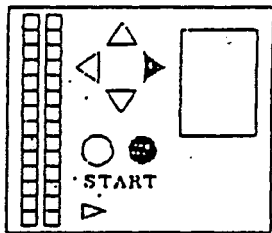

Right + ② button

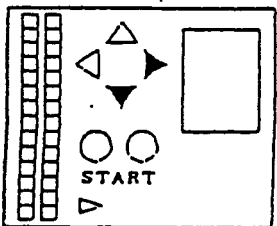

Lower Right

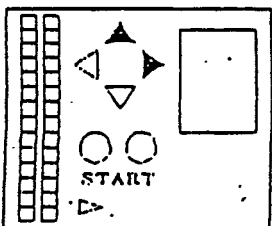

Upper Right

Operate "Right + Button ①, ②", "Up + Button ①, ②", "Left + Button ①, ②", "Down + Button ①, ②" and check if the clicking feeling of the PAD button ①, ② is normal, if the headphone sound is heard from left and right respectively, and if the quality of the sound is normal, etc.
 Go on the checking in the slant direction in the order of lower right, upper right, upper left and lower left.

CHECK 2. Check of the built-in speaker

Remove the headphone pin and perform the same manner as the check 1.

(Check in the slant direction canceled.)

Move the sound volume to the maximum and minimum and check if the sound is interlocked and the volume sound is smooth.

If there is no problem in the above check, switch to the next screen.

(Press START)

* At this point, check if there is any abnormality in the operation of the START button or in the click feeling.

SCREEN 2

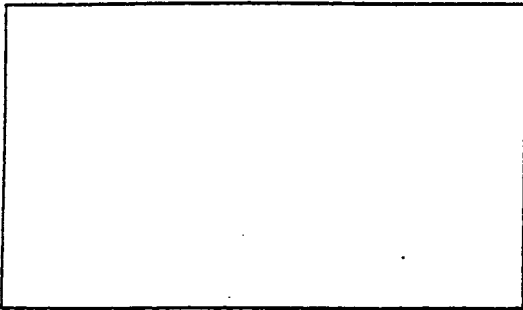

CHECK 3. Check of brightness (Contrast)

Move the brightness volume to the maximum and minimum and check if the light volume is interlocked to the movement and if there is any light unevenness, LCD stain, damage, spots, etc.

At this point, press the pad and buttons the respective colors and LCD (spot,dust, difference defects, etc.)

1. Red. 2. Yellow 1+2. Black

Upper: Green Lower: Green Left: Purple
Right: Pink

If there is no problem in the above check, switch to the next screen. (Press START)

SCREEN 3

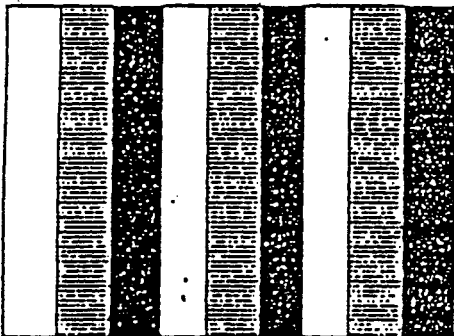

CHECK 4. Color check ①

Vertical color patterns appear.

Check if the hues are normal, or if there is any LCD stain, scratch, and spot etc.

If there is no problem in the above check, switch to the next screen. (Press START)

GG CHECK PROGRAM SPECIFICATION

CHECK PROGRAM AND ORDER

(I) Check the following 3 items in the state of black screen until the check screen (Fig.1) appears after turning on the power. If an error occurs, the error messages as shown in Table 1 appear in white characters on the red background. At this point, terminate the checking and stop further checking work.

- ① Scratch RAM R/W check
- ② V_RAM R/W check
- ③ Communication port check (Parallel & Serial)

(II) If the above check (I) is O.K., check the following 5 items as the check screen (Fig.1) appears.

- ④
- JOY port check
 - Color RAM check
 - Spright check
 - Sound check
 - Cross-talk check

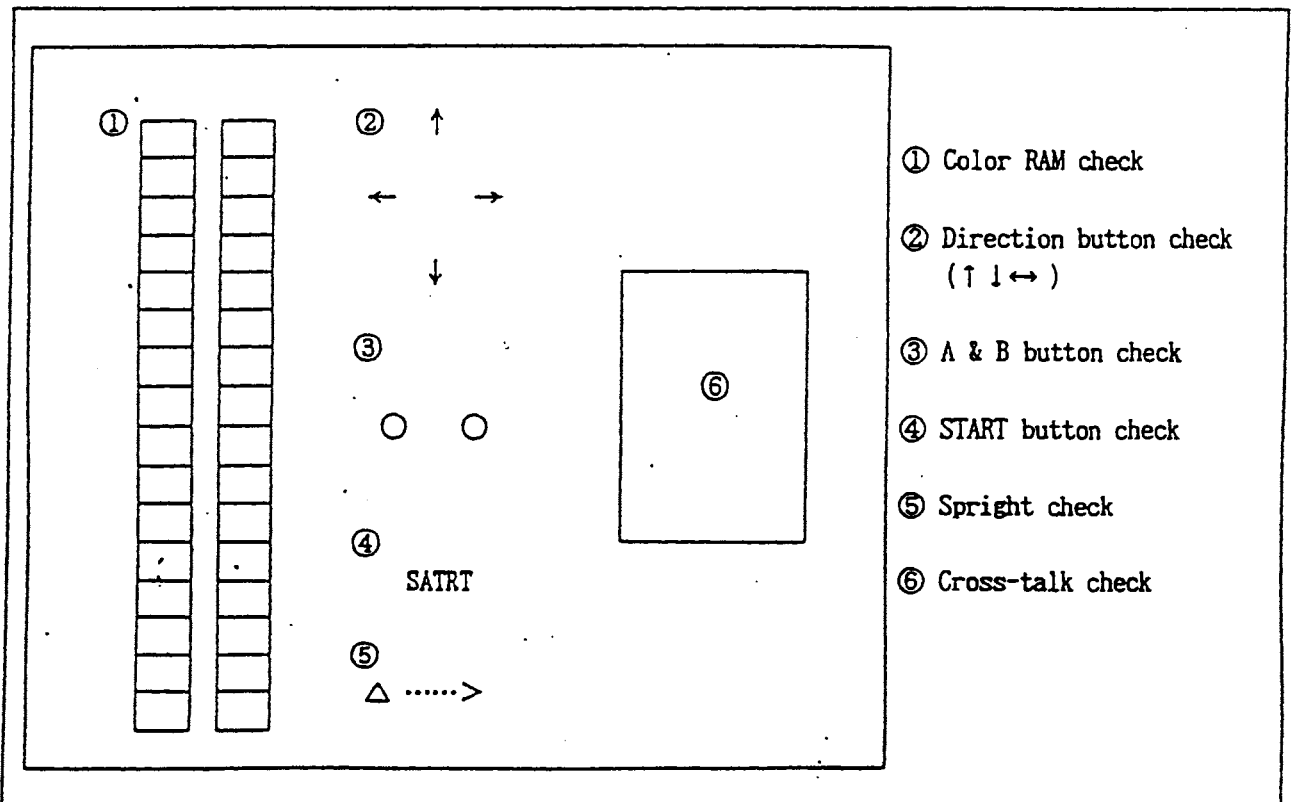

Fig. 1 Check screen

[CHECK METHOD OF EACH ITEM]

SCRATCH RAM CHECK

- ① Read after writing all 55h to C000h~DFFFh.
- ② Read after writing all AAh to C000h~DFFFh.
- ③ Write 1FFFh to C000h and C001h.
Write 1FFEh to C002h and C003h.

↓

Write 1000h to DFFEh and DFFFh.
Read the above values respectively.

V_RAM CHECK

- ① Read after writing all 55h to 0000h~3FFFh.
- ② Read after writing all AAh to 0000h~3FFFh.
- ③ Write 3FFFh to 0000h and 0001h.
Write 3FFEh to 0002h and 0003h.

↓

Write 2000h to 3FFEh and 3FFFh.
Read the above values respectively.

COMMUNICATION PORT
CHECK

- ① Serial communication check
- ② Parallel Communication check

{ The exclusive adaptor is required as checking is done by one(1) set. }

JOY PORT CHECK

- ① Checking of the direction button (↑ ↓ ↔),
A&B buttons and START button (if the button
is pressed, the corresponding porttion turns red.)

COLOR RAM CHECK

- ① Displaying of the 32 (colors) squares

SPRIGHT CHECK

- ① Move the arrow in right and left direction
with spright definition.

SOUND CHECK

- ① Check the (pseudo) stereo (left, right or left-right
simultaneousl by using an earphone). Three tones and
one noise are allocated to the direction buttons
(↑ ↓ ↔) and the distribution to left/right by stereo
is allocated to the A/B butons. For example,
if the (↑) button is turned on while pressing
the A button, the tone-1 is delivered to the left.
(If the left-right button is pressed in this state,
the output is made o the both sides.)

CROSS-TALK CHECK

.....① The white square is displayed on the black background. Check the extent of the cross-talk at the upper/lower parts.

Table-1. ERROR MESSAGE

S-RAM 不良 (S-RAM DEFECT)

.....At the point of scratch RAM check

V-RAM 不良 (V-RAM DEFECT)

.....At the point of V - RAM check

通信不良 (COMMUNICASION DEFECT)

.....At the point of communication port check

パッド不良 (PAD DEFECT)

..... At the point of JOY port check

Game Gear Hardware Checker

(Part No. 610-5176)

Issued on: Aug. 4, 1992

SEGA JAPAN.

1. General

This checker is designed to check the Printed Circuit Board Assembly for Game Gear.

2. Operation Flow

1. Connect the Checker to Pin Tool by using the connectors (14 pin, 24 pin, 36 pin, 2 pin, SUB PCB, START SW, SW2)
2. Connect the checker to TV by using Video Cable
3. Connect the checker to 100V outlet.
4. Turn the Checker Power on.
(“SET INSPECTED TARGET” is indicated on TV screen.)
5. Set the PCB Assy on Pin Tool.
6. Turn the “START SW” on
(Screen should be fade out and “CHECK VOLUME” is indicated on TV screen after about 2sec, then “VOLUME CHECK” is indicated on LCD screen)
7. Rotate the Volume Adjustment on PCB and check the “Level Gauge” on Volume Screen adjusted between 0 - 8 and also confirm the Indication of color Bar change the color from white to black.
LED on PCB should be lit on.
8. By pressing “SW2”, Finish the Volume Check function and “CHECK LED” on TV and Red Color Bar on LCD are indicated.
Then color bar should be change color from Red → Green → Blue by pressing “SW2”
9. Press “SW2” again and confirm the “CHECK LED” is indicated on both TV and LCD. In this condition, LED should blink.
10. After confirm the LED blinking, press “SW2” to change the screen for TV Mode Check. Confirm both LCD and TV has same indication in this condition. Then press “SW-2” again to change the TV screen to Error Check (Horizontal / Vertical Direction = Color Bar)
* In case of no error “TEST 10K” and in case of error “ERR POINT” and Error Point should be indicated.

11. Turn "START SW" off and remove PCB from Pin Tool
12. Repeat above procedure ⑤ - ⑪.

Note

1. If turn the "START SW" on without setting or improper setting of PCB Assy on Pin Tool or POWER SHORT ERROR is found, Checker will stop inspection and indicate "WARNING POWER SHORT ERROR CHECK STOP" on TV screen
2. If "BUS ERR" is found, checker do not execute item 7 and 8.
3. In case the Error other than "POWER SHORT ERROR" is found, all errors are indicated on Error Check Screen during TV Mode check. (As to Errors, Please refer to Error Message)
4. As to Volume Check, LCD Color Bar check, LED Check & TV Mode Screen check should be visible inspection. (Item 7, 8, 9 & 10)
5. Checker program can not perform the Visible Inspection.

3) Check Flow

Check Item (SYSTEM)

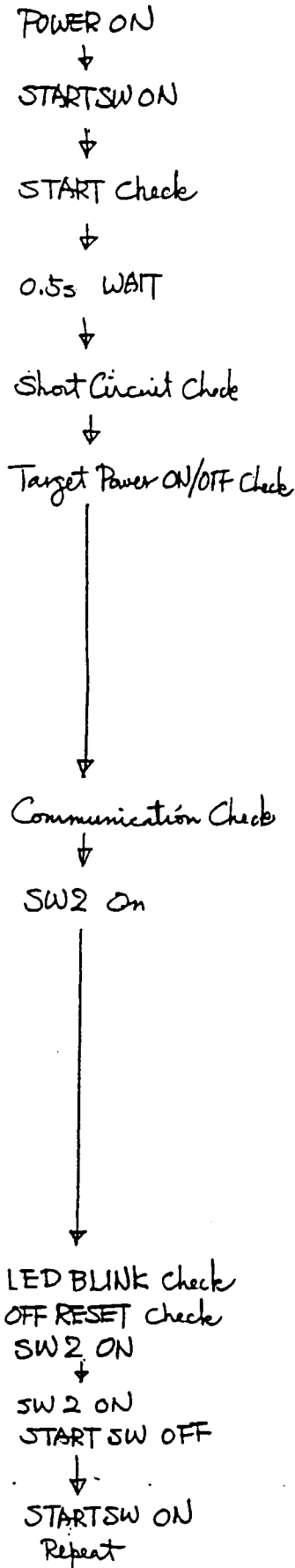

Check Item (TARGET)

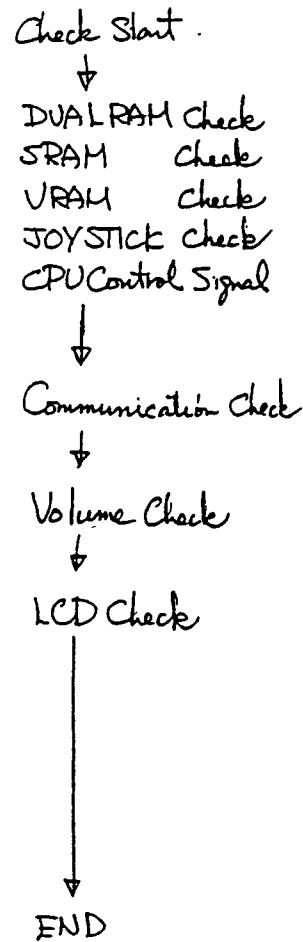

TV SCREEN

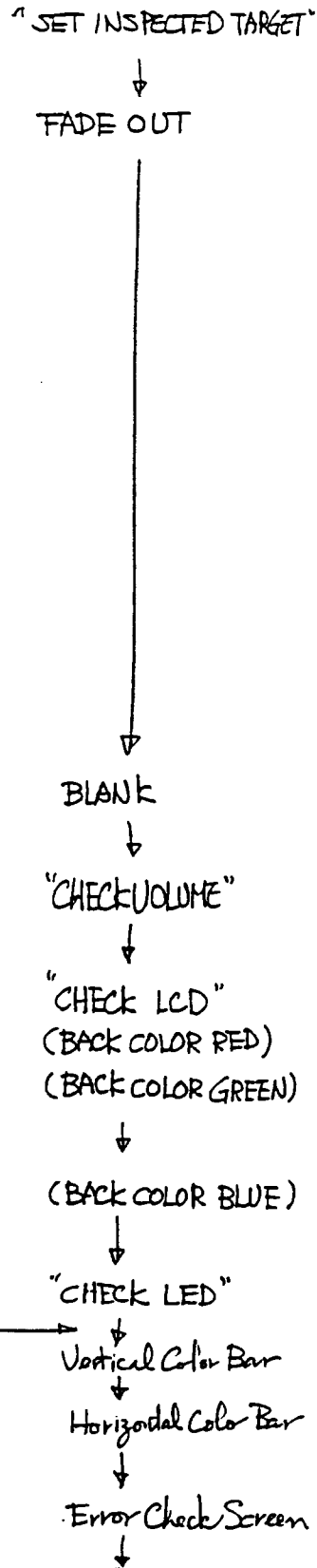

LCD SCREEN

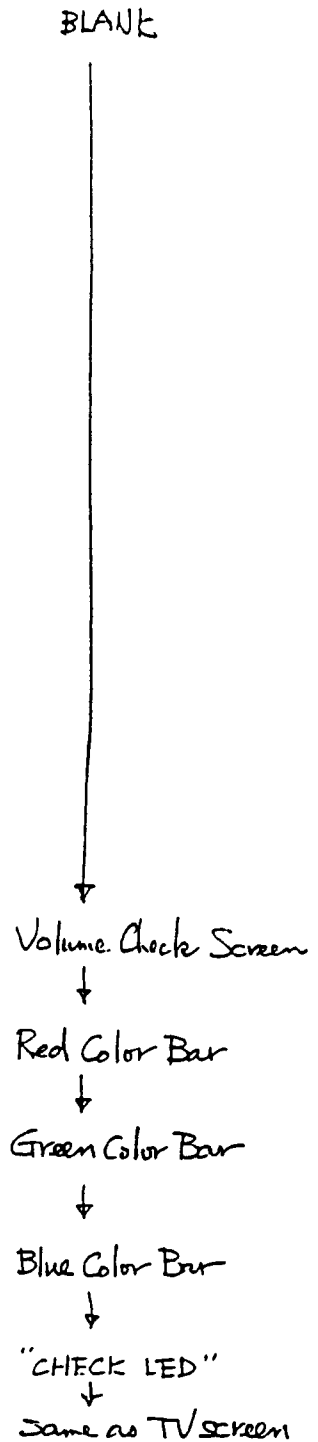

4) Error Message.

Errors except for "POWER SHORT ERROR" are discovered during inspection - shall be indicated on TV screen as "ERR POINT" after inspection. (If there is no error, "TEST 1 OK shall be indicated)

Error message is constructed from Main Error Message (Error Portion) and Sub Error Message (Error status or Further to define error portion)

(1) Error Indication

I. Standard Error Indication

ERR		POINT	
	Main Error Message ↑		↑ sub Error Message
POWER	H	S-RAM	
T5V	L	V-RAM	
T2.5V	H	JOYSTICK	↪ Main Error Message
VREF	L	012345	↪ Sub Error Message
VRES	H	CPU SIGNAL	
VONF	L	012345	
T34V	H	COMM	
FL-H	L	VOL OVER	
CURNT	L	ON RST FST	
		OFFSET SLW	

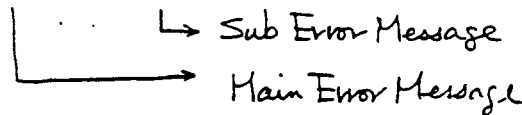

CHECK ERRORS = * * ↪ Total Error

II Bus Error Indication

ERR		POINT	
Main Error Message ↙		↗ Sub Error Message	
POWER	H	BUS	≈ BUS ERROR
+5V	L		
+2.5V	H		
VREF	L	ERR	
VRES	H		
VONF	L		
+34V	H		
FL-F	L		
FL-V	H		
CURNT	L	ON RST FST	
		OFF RST SLW	
		└───┬───> Sub Error Message	
		└───┴───> Main Error Message	
CHECK ERRORS = ** ≈ TOTAL ERROR			

In case of short circuit of Address, Data Bus and/or CN1, "Wire disconnection", "Pin Tool or Sub PCB Assy missetting" or "Defective CI" function check of PCB Assy shall not be executed to eliminate the uncontrolled program run. (Therefore, inspection between DUAL ROM check and LCD check shall not be performed.)

2). Power Short Error Indication.

In case of short circuit on PCB Assy or improper setting of PCB Assy, stop inspection to protect the PCB damage and indicate the following message

WARNING
POWER SHORT ERROR
CHECK STOP

If turn "START SW" off, screen returns to original ("SET INSPECTION TARGET").

(3) Error Message and Defective Portion

<u>No.</u>	<u>Main Error</u>	<u>Sub Error</u>	<u>Defective Portion</u>	<u>Note</u>
Ⓐ	POWER	H or L	Short Circuit or Improper setting	Due to POWER SHORT ERROR, this is not indicated as long as program runs correctly.
Ⓑ	T5V	H or L	Battery Board (837-7399-01)	ANALOG 5V signal is not within standard Voltage.
Ⓒ	+2.5V	H or L	R48, R49, C48 Battery Board	+2.5V is not within standard Voltage
Ⓓ	VREF	H or L	IC3-PIN30 Battery Board	Vref signal is not within standard Voltage.
Ⓔ	VRES	H or L	IC3-PIN32, R50, R51, R52 D4, C49 Battery Board	Vres signal is not within standard Voltage
Ⓕ	VONF	H or L	IC3-PIN31, R50, R51, R52 D4, C49.	Vonf signal is not within standard Voltage
Ⓖ	T34V	H or L	Battery	T34V signal is not within standard Voltage.
Ⓗ	FL-F	H or L	Around T1, Q3, Q4	FL Frequency is out of spec.
Ⓘ	FL-V	H or L	"	FL Voltage is out of spec.
Ⓣ	CURNT	H or L	IC2, IC5, Resistor, Capacitor, Soldering of IC, Misselling.	Current is out of spec
Ⓚ	S-RAM	Non	IC4, IC2, IC1	Internal RAM operate correctly?
Ⓛ	V-RAM	Non	IC5, IC2, IC1.	V-RAM operate correctly?
Ⓜ	JOYSTICK	0-5	IC3, Pattern on PCB	Data can transfer to JOYSTICK PORT * 1
Ⓝ	CPU SIGNAL	0-5	IC1, IC3. X1 Misccontact on Pin Tool	Check CPU Signal * 1
Ⓞ	COMM	0~6	IC3, CW2, EM1~EM8, X1	Communication done in proper way. * 1.

① VOL OVER	Non	IC3, IC6, IC2 SOUNDBOARD (837-7400-01)	SOUND Output is more than spec. ("LEVEL OVER" is indicated on Volume Check Screen)
② ON RST	FST or SLW	IC3, Battery Board RD~52, D4, C49 inspection did not execute correctly	Reset signal is not generated for required period during power on stage.
③ OFF RST	FST or SLW	IC3, Battery Board RD~52, D4, C49 inspection did not execute correctly.	

(4) Sub Error Message

I. H or L (A ~ J)

H: Inspected value is higher than spec. (High)

L: Inspected value is lower than spec. (Low)

II. FST or SLW (Q, R)

FST: During Power On or off stage, Reset signal raises or drops earlier than spec. (FAST)

SLW: During Power on or off stage, Reset signal raises or drops slower than spec. (SLOW)

III JOYSTICK 0 ~ 5 (M)

<u>SUB ERROR</u>	<u>Defective Portion</u>	<u>Note.</u>
0	IC3, Pattern on PCB	PAD SW do not became all on condition
1	IC3, Pattern on PCB	PAD SW do not became all off condition
2	IC3, Pattern on PCB	Upper, Right, SW1 do not became on
3	IC3, Pattern on PCB	Lower, Left, SW2 do not became on.
4	=	PAUSE/START SW do not became on
5	=	PAUSE/START SW do not became off.

7 CPU SIGNAL 0~5 (㉑)

<u>SUB ERROR</u>	<u>Defective Portion</u>	<u>Note.</u>
0	IC1 - PIN 20	IDPQ does not generate correctly.
1	IC1 - PIN 27	M1 does not generate correctly.
2	IC1 - PIN 28	RFSH does not generate correctly.
3	IC3 - PIN 35, X1	CCLK does not generate correctly.
4	IC1 - PIN 24, R2	WAIT does not generate correctly.
5	IC1 - PIN 24, R1	BUSRQ does not generate correctly.

Communication 1~6 (㉒)

<u>SUB ERROR</u>	<u>Defective Portion</u>	<u>Note.</u>
0	IC3, CN2, EM1~EM8	Input data does not match with instructed value.
1	IC3, CN2, EM1~EM8	Cannot input data.
2	IC3, CN2, EM1~EM8	Output data does not match with instructed value.
3	IC3, CN2, EM1~EM8	Cannot output data.
4	IC3, CN2, X1	Cannot output 4800 BPS.
5	IC3, CN2, X1	Cannot output 2400 BPS.
6	IC3, CN2, X1	Cannot output the data with 2400 BPS.

Note.

In case 0~3 and 4 error is indicated, 0~3 sub error is happened during data input/output with 4800 BPS.

⑤ Note about sub Error.

- I. H and L Sub Error does not generate at the same time for 1 Main Error.
- II. FST and SLW Sub Error does not generate at the same time for 1 Main Error
- III. Ⓐ ~ Ⓓ, Ⓔ and Ⓕ error is generated, How L, FST or SLW Sub Error should be generated after Main Error. So, these error is making 1 error with the combination of Sub and Main Error.
Therefore, if SUB Error is not generated after Main Error, there may be some chance program does not run properly.
- IV. 0 ~ 6 Sub Error generate for Ⓐ, Ⓓ and Ⓔ Main Error, 1 numeric is match for 1 Error. Therefore, there is possibility more than 1 numeric is generated. And as explained in above item III, Sub Error and Main Error is always making pair.

Visual Check.

Please perform the Visual Check on the following 4 items. And, Visual Check portions are "LCD Screen on Checker" and "LED on Checking PCB"

Checker program did not have this function.

<u>No</u>	<u>Visual Check Point</u>	<u>Check Item</u>	<u>Defective Partion</u>
㊸	LCD Screen (Volume Check)	When turn the VOL adjuster on PCB, check the level gauge in "VOLUME CHECK" screen moves 0-8 / P-0.	SOUND BOARD (837-7400-01), IC6, IC3, IC2, R3~R10, C8~C11.
㊸	LCD Screen (LCD Check)	Check the color bar changed the color Red → Green → Blue, by pressing SW2. (Specially on Red Color Bar, Black line at color changing portion should not be observed)	IC3, IC2, IC5
㊸	LED (LED CHECK)	check LED-blinking on PCB at "CHECK LED" screen	LD1, IC3, R11 Battery PCB (837-7399-01)
㊸	LCD Screen (TV Mode Check)	Check there is no difference between LCD screen and TV screen in TV mode	IC3, CN1

5) Others

① Meter Relay.

Meter Relay observes the power consumption of GGT.

Setting Value should be in between "LOW side = +0360" and "HI SIDE = +0430".

This setting has enough allowance even if parts specification value maybe fluctuated. So, please try to set above gap as much as narrow.

This error is indicated as **① CURRENT** on screen.

② CN2

Inspection starts as soon as CN2 is activated. Please make sure CN2 is activated after "Cam SW makes contact" and "Pin or Pin Tool contact to points completely".

③ CN4

Please connect the Push SW which is used at Inspection. And Pin # 1 and # 3 should be used.

Moment Type Switch should be used also.

④ Radiator for IC2 & IC9

Please mount the proper radiator on IC2 (uPC 817), IC9 is not required to mount any radiator.

Please do not use the radiator jointly between IC2 & IC9.

⑤ Pattern Correction

The following pattern layout modifications should be required on 837-7617 Board.

- a. $\pm V$ of AC/12VDC and AC/5VDC should be jumpered at both side of PCB
- b. 10 pin of IC5, IC8 and IC12, should be disconnected and connected to pin # 11
- c. Add 74HC4066 and connect the pin # 1 to Pin # 1 of IC36, Pin # 2 to Pin # 24 of CN3 and pin # 13 to Pin # 1 of IC38.
- d. Cut the pattern between Pin # 1 of IC37 and Pin # 24 of CN3
- e. Disconnect pin # 64 of IC28 and jumper to pin # 65 line.
- f. Jumper the pin # 14 of IC44 to GND
- g. Disconnect Pin # 3 and # 45 of IC41 and these disconnected lines should be connected to Pin # 48 through 1K Ω Resistors. And disconnected Pin # 3 should be connected the line used to connect with Pin # 45 through 120 Ω Resistor.

Disconnected Pin #45 should be connected to the line used to connect with Pin #3 through 120 Ω Resistor.

) Caution

1. Since more than 300 V high Voltage line on 837-7619 PCB Assy (ASSY GG CHECKER LCD) - Please handle very carefully.
2. 36 wire cable length for Pin Tool should be minimized. If cable is too long, you may observe LCD screen interference.
3. Please turn on the checker 10 minute before inspection.

GAME GEAR

EUROPE

PARTS SPECIFICATION

ピン配置図(上面図)

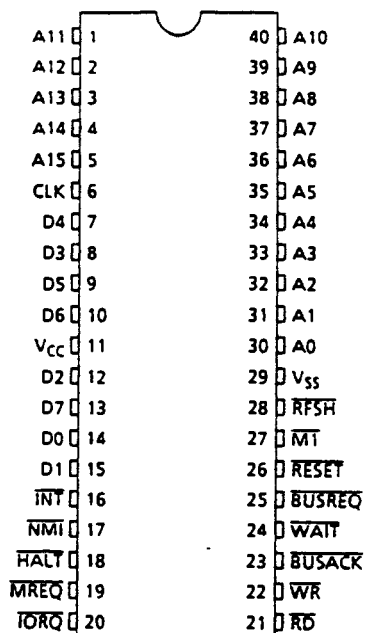

SSOP40-P-450

単位: mm

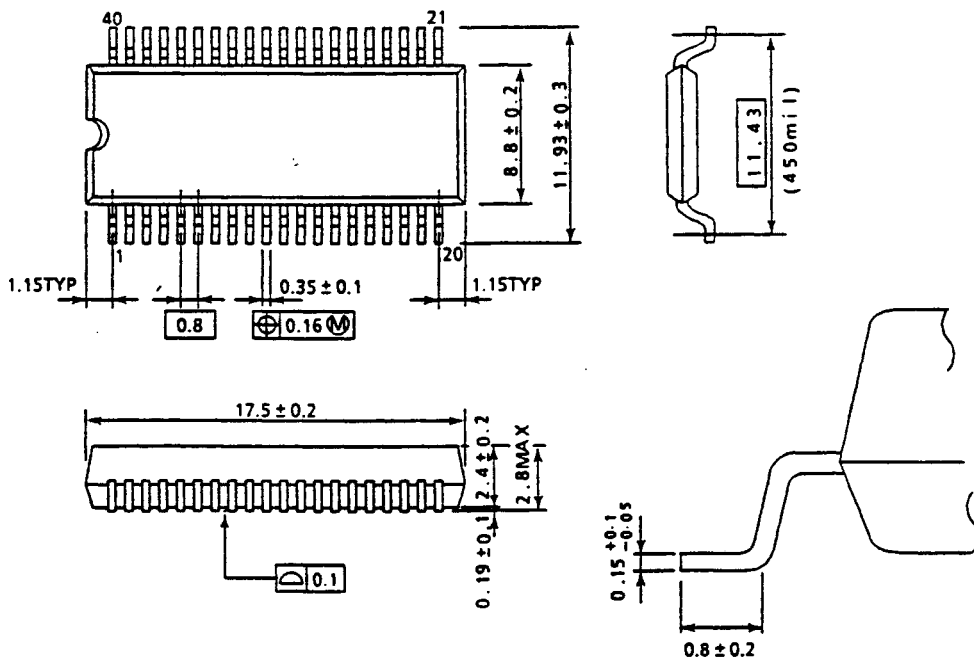

270289

ピン名称と機能

ピン名称	ピン数	入/出力 3ステート	機 能
A0-A15	16	出 力 3ステート	16ビットのアドレスバス。 アクセスするメモリや入出力ポートのアドレス指定を行います。リフレッシュ期間中はリフレッシュ用アドレスが出力されます。
CLK	1	入 力	単相のクロック入力。 クロック入力にDC状態("1"レベルまたは"0"レベル継続)になるとMPUは動作を停止し、そのときの状態を保持します。
D0-D7	8	入出力 3ステート	8ビットの双方向性データバス。
INT	1	入 力	マスカブル割込み要求信号。 割込みは周辺LSIから起動されます。ソフトウェアによって、割込み許可フリップフロップ(IFF)が"1"にセットされていれば受けられます。INTは通常ワイヤードオアで使用され、その場合はプルアップ抵抗を外部に付加します。
NMI	1	入 力	ノンマスカブル割込み要求信号。 この割込み要求は、マスカブル割込みより優先度が高く、割込み許可フリップフロップ(IFF)の状態に依存しません。
HALT	1	出 力	ホールド信号。 MPUがHALT命令を実行し、ホールド状態になると"0"が出力されます。
MREQ	1	出 力 3ステート	メモリリクエスト信号。 メモリアクセスのための有効アドレスがアドレスバスに乗っているときに"0"が出力されます。また、メモリリフレッシュ期間中もRFSH信号とともに"0"となります。
IORQ	1	出 力 3ステート	入出力リクエスト信号。 入出力動作で入出力のためのアドレスがアドレスバスの下位8ビット(A0-A7)に乗っているときに"0"が出力されます。また、IORQ信号は割込みアクノリッジ時にINT信号とともに出力され、割込み応答ベクトルをデータバス上に乗せてもよいことを周辺LSIに知らせます。
RFSH	1	出 力	リフレッシュ信号。 ダイナミックメモリのリフレッシュ用アドレスがアドレスバスの下位7ビットに乗っているとき"0"が出力されます。このとき、MREQ信号もアクティブ状態("0")になります。
MT	1	出 力	マシンサイクル1を示す信号。 命令のオペコードフェッチサイクルでMREQとともに"0"が出力されます。2バイトのオペコード実行時には、オペコードフェッチごとに出力されます。マスカブル割込みアクノリッジサイクルではIORQ信号とともに出力されます。
RESET	1	入 力	リセット信号。 RESET信号は、MPUの初期化を行う信号で少なくとも3クロック期間アクティブ状態("0")にしなければなりません。
BUSREQ	1	入 力	バスリクエスト信号。 BUSREQ信号はMPUのアドレスバス、データバス、MREQ、IORQ、RD、WRを高インピーダンス状態にすることを要求する信号です。BUSREQ信号は通常ワイヤードオアで使用され、その場合はプルアップ抵抗を外部に付加します。
WAIT	1	入 力	ウェイト信号。 WAIT信号は、MPUに対して指定されたメモリあるいは周辺LSIがデータ転送準備ができていないことを知らせます。 WAIT信号が"0"である限り、MPUはウェイト状態を継続します。
BUSACK	1	出 力	バスアクノリッジ信号。 BUSREQ信号を受けて、周辺LSIに対して、MPUのアドレスバス、データバス、MREQ、IORQ、RD、WRが高インピーダンス状態になったことを知らせます。
WR	1	出 力 3ステート	ライト信号。 指定したメモリあるいは周辺LSIに格納すべきデータがMPUデータバスに乗っているとき出力されます。
RD	1	出 力 3ステート	リード信号。 MPUがメモリまたは周辺LSIからデータを受入れ可能な期間、"0"が出力されます。指定された周辺LSIあるいはメモリのデータをこの信号でゲートし、MPUのデータバスに乗せることができます。
NC (PLCCのみ)	4	-	内部には接続されていません。 オープンで使用して下さい。
Vcc	1	電 源	+5V
Vss	1	電 源	0V

PARTS LIST

PART NO. : 837-7996B

DESCRIPTION : IC BD GG MAIN EUROPE B

LINE	LOCATE	DNO OR	PART NO.	DESCRIPTION
61.00	R14	126	476-2201-J-10	RES CHIP 200 OHM 1/10W 5%
62.00	R17	133	476-2472-J-10	RES CHIP 4.7KOHM 1/10W 5%
63.00	R18	134	476-2103-J-10	RES CHIP 10KOHM 1/10W 5%
64.00	R20 (SOLDER)	129	476-2102-J-10	RES CHIP 1KOHM 1/10W 5%
65.00	R21 (SOLDER)	129	476-2102-J-10	RES CHIP 1KOHM 1/10W 5%
66.00	R22 (SOLDER)	134	476-2103-J-10	RES CHIP 10KOHM 1/10W 5%
67.00	R23 (SOLDER)	129	476-2102-J-10	RES CHIP 1KOHM 1/10W 5%
68.00	R24 (SOLDER)	129	476-2102-J-10	RES CHIP 1KOHM 1/10W 5%
69.00	R25 (SOLDER)	134	476-2103-J-10	RES CHIP 10KOHM 1/10W 5%
70.00	R26	138	476-2473-J-10	RES CHIP 47KOHM 1/10W 5%
71.00	R27	138	476-2473-J-10	RES CHIP 47KOHM 1/10W 5%
72.00	R28	910	NOT USED	NOT USED
73.00	R29	130	476-2182-J-10	RES CHIP 1.8KOHM 1/10W 5%
74.00	R30	130	476-2182-J-10	RES CHIP 1.8KOHM 1/10W 5%
75.00	R31	139	476-2104-J-10	RES CHIP 100KOHM 1/10W 5%
76.00	R32	139	476-2104-J-10	RES CHIP 100KOHM 1/10W 5%
77.00	R33	172	476-2303-J-10	RES CHIP 30KOHM 1/10W 5%
78.00	R34	135	476-2203-J-10	RES CHIP 20KOHM 1/10W 5%
79.00	R35	125	476-2510-J-10	RES CHIP 51 OHM 1/10W 5%
80.00	R36	148	476-2563-F-10	RES CHIP 56KOHM 1/10W 1%
81.00	R37	146	476-2303-F-10	RES CHIP 30KOHM 1/10W 1%
82.00	R38	125	476-2510-J-10	RES CHIP 51 OHM 1/10W 5%
83.00	R39	143	476-2471-F-10	RES CHIP 470 OHM 1/10W 1%
84.00	R40	143	476-2471-F-10	RES CHIP 470 OHM 1/10W 1%
85.00	R41	131	476-2222-J-10	RES CHIP 2.2KOHM 1/10W 5%
86.00	R42	140	476-2244-J-10	RES CHIP 240KOHM 1/10W 5%
87.00	R43	136	476-2223-J-10	RES CHIP 22KOHM 1/10W 5%
88.00	R44	136	476-2223-J-10	RES CHIP 22KOHM 1/10W 5%
89.00	R45	142	476-2105-J-10	RES CHIP 1MOHM 1/10W 5%
90.00	R46	136	476-2223-J-10	RES CHIP 22KOHM 1/10W 5%
91.00	R47	136	476-2223-J-10	RES CHIP 22KOHM 1/10W 5%
92.00	R48 (SOLDER)	134	476-2103-J-10	RES CHIP 10KOHM 1/10W 5%
93.00	R49 (SOLDER)	134	476-2103-J-10	RES CHIP 10KOHM 1/10W 5%
94.00	R50	174	476-2912-F-10	RES CHIP 9.1KOHM 1/10W 1%
95.00	R51	173	476-2112-F-10	RES CHIP 1.1KOHM 1/10W 1%
96.00	R52	175	476-2302-F-10	RES CHIP 3KOHM 1/10W 1%
97.00	R53 (SOLDER)	171	476-2122-J-10	RES CHIP 1.2KOHM 1/10W 5%
98.00	R54	127	476-2221-J-10	RES CHIP 220 OHM 1/10W 5%
99.00	R55	127	476-2221-J-10	RES CHIP 220 OHM 1/10W 5%
100.00	R56	127	476-2221-J-10	RES CHIP 220 OHM 1/10W 5%
101.00	R57	127	476-2221-J-10	RES CHIP 220 OHM 1/10W 5%
102.00	R58	127	476-2221-J-10	RES CHIP 220 OHM 1/10W 5%
103.00	R59	127	476-2221-J-10	RES CHIP 220 OHM 1/10W 5%
104.00	R60 (SOLDER)	127	476-2221-J-10	RES CHIP 220 OHM 1/10W 5%
105.00	R61 (SOLDER)	127	476-2221-J-10	RES CHIP 220 OHM 1/10W 5%
106.00	R62 (SOLDER)	127	476-2221-J-10	RES CHIP 220 OHM 1/10W 5%
107.00	R63 (SOLDER)	127	476-2221-J-10	RES CHIP 220 OHM 1/10W 5%
108.00	R64	910	NOT USED	NOT USED
109.00	C1	165	150-0311	CAP E CHIP 33UF 6.3V M
110.00	C3	163	150-0308	CAP E CHIP 10UF 6.3V M
111.00	C4	157	151-0265	CAP CER CP 0.1UF 25V ZF 2125
112.00	C5	157	151-0265	CAP CER CP 0.1UF 25V ZF 2125
113.00	C6	163	150-0308	CAP E CHIP 10UF 6.3V M
114.00	C7	157	151-0265	CAP CER CP 0.1UF 25V ZF 2125
115.00	C8 (SOLDER)	158	151-0266	CAP CER CP 0.33UF 25V Z F 3216
116.00	C9 (SOLDER)	158	151-0266	CAP CER CP 0.33UF 25V Z F 3216
117.00	C10 (SOLDER)	158	151-0266	CAP CER CP 0.33UF 25V Z F 3216
118.00	C11 (SOLDER)	158	151-0266	CAP CER CP 0.33UF 25V Z F 3216
119.00	C12 (SOLDER)	157	151-0265	CAP CER CP 0.1UF 25V ZF 2125
120.00	C14	157	151-0265	CAP CER CP 0.1UF 25V ZF 2125

PARTS LIST

PART NO. : 837-7996B

DESCRIPTION : IC BD GG MAIN EUROPE B

LINE	LOCATE	DNO	OR	PART NO.	DESCRIPTION
1.00		1		171-6101A	PC BD GG MAIN EUROPE
2.00	IC1	101		315-0545	IC 280A C-MOS SOP TMP84C00AM-6
3.00	IC2	102		315-5377	IC CUSTOM CHIP VDP GG QFP
4.00	IC3	103		315-5378B	IC CUSTOM CHIP SCA GG QFP
5.00	IC4	104	1	315-0546	IC UPD4364G-15L SOP 28P
6.00	IC4	104	2	315-0611	IC FCBG1C65L-70T SOP 28P
7.00	IC5 (SOLDER)	105		315-0547	IC HM65256BLEP-12 SOP 28P
8.00	IC6 (SOLDER)	106		313-5134	IC UPC358G2 SOP 8P
9.00	Q1	108		482-5126	XSTR 2SC1623 L5..7 CHIP
10.00	Q2	910		NOT USED	NOT USED
11.00	Q3 (SOLDER)	109		482-5127	XSTR 2SD1614 CHIP
12.00	Q4 (SOLDER)	109		482-5127	XSTR 2SD1614 CHIP
13.00	Q5	108		482-5126	XSTR 2SC1623 L5..7 CHIP
14.00	Q6	108		482-5126	XSTR 2SC1623 L5..7 CHIP
15.00	Q7	108		482-5126	XSTR 2SC1623 L5..7 CHIP
16.00	Q8	107		482-5125	XSTR 2SA812 M5..7 CHIP
17.00	Q9	108		482-5126	XSTR 2SC1623 L5..7 CHIP
18.00	Q10	107		482-5125	XSTR 2SA812 M5..7 CHIP
19.00	Q11	108		482-5126	XSTR 2SC1623 L5..7 CHIP
20.00	FB1	910		NOT USED	NOT USED
21.00	LD1 (SOLDER)	110		390-5308	LED SLR 34-VT3F
22.00	D1	111		481-5072	DIODE 1SS184 CHIP
23.00	D2	111		481-5072	DIODE 1SS184 CHIP
24.00	D3	111		481-5072	DIODE 1SS184 CHIP
25.00	D4	111		481-5072	DIODE 1SS184 CHIP
26.00	X1	112		230-5066	XTAL OSC 32.215905M 100PPM
27.00	CN1	113		209-5037	CONN 45P FOR GG 01-176914-1-
27.10	CN1	113		209-5037-01	CONN 45P FOR GG 01
28.00	CN2	114		209-5038	CONN 10P FOR GG HDC-0492
29.00	CN3	115		212-5304	CONN 6P FOR GG 178094-6
30.00	CN4	116		212-5305	CONN 9P FOR GG 178094-9
31.00	FU1	117		514-5040	FUSE THERMAL SMO95B0
32.00	FU2	117		514-5040	FUSE THERMAL SMO95B0
33.00	1	118		048-0001	EYLET 3.5*7
34.00	2	118		048-0001	EYLET 3.5*7
35.00	EM1	119		271-0007	EMI FILTER STX222MB
36.00	EM2	119		271-0007	EMI FILTER STX222MB
37.00	EM3	119		271-0007	EMI FILTER STX222MB
38.00	EM4	119		271-0007	EMI FILTER STX222MB
39.00	EM5	119		271-0007	EMI FILTER STX222MB
40.00	EM6	119		271-0007	EMI FILTER STX222MB
41.00	EM7	119		271-0007	EMI FILTER STX222MB
42.00	EM8	119		271-0007	EMI FILTER STX222MB
43.00	L1	120		271-0017	BEADS INDUCTOR FBA04VA900AB-00
44.00	L3	121		180-5073	P.COIL CHIP 100UH LEM4532T101K
45.00	L2	122		180-5077	CHOKE COIL 105UH KI-1589
46.00	T1	123		560-5172	INVERTER XFMR KI-1588
47.00	VR1	124		220-5339	VOL CONT 20KB RKO9J11T0
48.00	R1	133		476-2472-J-10	RES CHIP 4.7KOHM 1/10W 5%
49.00	R2	133		476-2472-J-10	RES CHIP 4.7KOHM 1/10W 5%
50.00	R3 (SOLDER)	133		476-2472-J-10	RES CHIP 4.7KOHM 1/10W 5%
51.00	R4 (SOLDER)	133		476-2472-J-10	RES CHIP 4.7KOHM 1/10W 5%
52.00	R5 (SOLDER)	133		476-2472-J-10	RES CHIP 4.7KOHM 1/10W 5%
53.00	R6 (SOLDER)	133		476-2472-J-10	RES CHIP 4.7KOHM 1/10W 5%
54.00	R7 (SOLDER)	141		476-2474-J-10	RES CHIP 470KOHM 1/10W 5%
55.00	R8 (SOLDER)	141		476-2474-J-10	RES CHIP 470KOHM 1/10W 5%
56.00	R9 (SOLDER)	141		476-2474-J-10	RES CHIP 470KOHM 1/10W 5%
57.00	R10 (SOLDER)	141		476-2474-J-10	RES CHIP 470KOHM 1/10W 5%
58.00	R11	128		476-2471-J-10	RES CHIP 470 OHM 1/10W 5%
59.00	R12 (SOLDER)	133		476-2472-J-10	RES CHIP 4.7KOHM 1/10W 5%
60.00	R13	132		476-2302-J-10	RES CHIP 390OHM 1/10W 5%

PARTS LIST

PART NO. : 837-7996B

DESCRIPTION : IC BD GG MAIN EUROPE B

LINE	LOCATE	DNO OR PART NO.	DESCRIPTION
176.00	C70	151 151-0291	CAP CER CP 39PF 50V K SL 160
177.00	C71	151 151-0291	CAP CER CP 39PF 50V K SL 160
178.00	C72	151 151-0291	CAP CER CP 39PF 50V K SL 160
179.00	C73	151 151-0291	CAP CER CP 39PF 50V K SL 160
180.00	C74	151 151-0291	CAP CER CP 39PF 50V K SL 160
181.00	C75	910 NOT USED	NOT USED
182.00	C76	177 151-0307	CAP CER CP 0.022UF 50V ZF212
183.00	C77	177 151-0307	CAP CER CP 0.022UF 50V ZF212
184.00	C78	178 151-0298	CAP CER CP 100PF 50V J SL 212
185.00	C79	910 NOT USED	NOT USED
186.00	C80	157 151-0265	CAP CER CP 0.1UF 25V ZF 212
187.00	C81	177 151-0307	CAP CER CP 0.022UF 50V ZF212
188.00	C82	179 151-0320	CAP CER CP 68PF 50V J CH 212
189.00	C83	181 151-0323	CAP CER CP 33PF 50V K SL 212
190.00	C84	182 151-0340	CAP CER CP 5PF 50V D CH 212
191.00	C85	181 151-0323	CAP CER CP 33PF 50V K SL
192.00		930 NOTE#1	NOTE LINE
193.00		931 NOTE#2	NOTE LINE
194.00		932 NOTE#3	NOTE LINE

PARTS LIST

PART NO. : 837-7996B

DESCRIPTION : IC BD GG MAIN EUROPE B

LINE	LOCATE		DNO OR PART NO.	DESCRIPTION
121.00	C15	(SOLDER)	149 151-0289	CAP CER CP 10PF 50V D CH 212
122.00	C16	(SOLDER)	149 151-0289	CAP CER CP 10PF 50V D CH 212
123.00	C17		170 1 153-0090	CAP TANT CHIP 1UF 10V
124.00	C17		170 2 153-0086	CAP TANT CHIP 1UF 16V
125.00	C18		155 151-0264	CAP CER CP 8200PF 50V K B 212
126.00	C19	(SOLDER)	157 151-0265	CAP CER CP 0.1UF 25V ZF 212
127.00	C20	(SOLDER)	170 1 153-0090	CAP TANT CHIP 1UF 10V
128.00	C20	(SOLDER)	170 2 153-0086	CAP TANT CHIP 1UF 16V
129.00	C21		170 1 153-0090	CAP TANT CHIP 1UF 10V
130.00	C21		170 2 153-0086	CAP TANT CHIP 1UF 16V
131.00	C22		155 151-0264	CAP CER CP 8200PF 50V K B 212
132.00	C23	(SOLDER)	170 1 153-0090	CAP TANT CHIP 1UF 10V
133.00	C23	(SOLDER)	170 2 153-0086	CAP TANT CHIP 1UF 16V
134.00	C24		154 151-0263	CAP CER CP 2200PF 50V K B 212
135.00	C25		154 151-0263	CAP CER CP 2200PF 50V K B 212
136.00	C26		154 151-0263	CAP CER CP 2200PF 50V K B 212
137.00	C27		154 151-0263	CAP CER CP 2200PF 50V K B 212
138.00	C28		154 151-0263	CAP CER CP 2200PF 50V K B 212
139.00	C29		154 151-0263	CAP CER CP 2200PF 50V K B 212
140.00	C30		154 151-0263	CAP CER CP 2200PF 50V K B 212
141.00	C31		167 150-0313	CAP E CHIP 100UF 6.3V M
142.00	C32		169 152-0177	CAP MP 0.1UF 100V 10%
143.00	C33		159 151-0272	CAP CER 270PF 2KV SL
144.00	C34		157 151-0265	CAP CER CP 0.1UF 25V ZF 212
145.00	C35		162 150-0307	CAP E CHIP 4.7UF 35V
146.00	C36		157 151-0265	CAP CER CP 0.1UF 25V ZF 212
147.00	C37		166 150-0318	CAP E CHIP 68UF 6.3V
148.00	C38		157 151-0265	CAP CER CP 0.1UF 25V ZF 212
149.00	C39		168 150-0319	CAP E CHIP 100UF 4V
150.00	C40		157 151-0265	CAP CER CP 0.1UF 25V ZF 212
151.00	C41		157 151-0265	CAP CER CP 0.1UF 25V ZF 212
152.00	C42		156 151-0271	CAP CER CP 0.01UF 50V ZF 212
153.00	C43		156 151-0271	CAP CER CP 0.01UF 50V ZF 212
154.00	C44		161 150-0317	CAP E CHIP 0.47UF 50V
155.00	C45		161 150-0317	CAP E CHIP 0.47UF 50V
156.00	C46		152 151-0270	CAP CER CP 47PF 50V K SL 212
157.00	C47		152 151-0270	CAP CER CP 47PF 50V K SL 212
158.00	C48		163 150-0308	CAP E CHIP 10UF 6.3V M
159.00	C49		164 150-0309	CAP E CHIP 22UF 6.3V M
160.00	C50		157 151-0265	CAP CER CP 0.1UF 25V ZF 212
161.00	C51		157 151-0265	CAP CER CP 0.1UF 25V ZF 212
162.00	C52		160 151-0286	CAP CER CHIP 0.47UF 16V Z F
163.00	C53		160 151-0286	CAP CER CHIP 0.47UF 16V Z F
164.00	C58	(SOLDER)	153 151-0290	CAP CER CP 1200PF 50V K B 212
165.00	C59		151 151-0291	CAP CER CP 39PF 50V K SL 160
166.00	C60		151 151-0291	CAP CER CP 39PF 50V K SL 160
167.00	C61		151 151-0291	CAP CER CP 39PF 50V K SL 160
168.00	C62		151 151-0291	CAP CER CP 39PF 50V K SL 160
169.00	C63		151 151-0291	CAP CER CP 39PF 50V K SL 160
170.00	C64		151 151-0291	CAP CER CP 39PF 50V K SL 160
171.00	C65		151 151-0291	CAP CER CP 39PF 50V K SL 160
172.00	C66		151 151-0291	CAP CER CP 39PF 50V K SL 160
173.00	C67		151 151-0291	CAP CER CP 39PF 50V K SL 160
174.00	C68		151 151-0291	CAP CER CP 39PF 50V K SL 160
175.00	C69	(SOLDER)	150 151-0288	CAP CER CP 39PF 50V K SL 212

PARTS LIST

PART NO. : 837-7996
 DESCRIPTION : IC BD GG MAIN EUROPE

LINE	LOCATE	DNO	OR	PART NO.	DESCRIPTION
173.00	C67	151		151-0291	CAP CER CP 39PF 50V K SL 160
174.00	C68	151		151-0291	CAP CER CP 39PF 50V K SL 160
175.00	C69 (SOLDER)	150		151-0288	CAP CER CP 39PF 50V K SL 212
176.00	C70	151		151-0291	CAP CER CP 39PF 50V K SL 160
177.00	C71	151		151-0291	CAP CER CP 39PF 50V K SL 160
178.00	C72	151		151-0291	CAP CER CP 39PF 50V K SL 160
179.00	C73	151		151-0291	CAP CER CP 39PF 50V K SL 160
180.00	C74	151		151-0291	CAP CER CP 39PF 50V K SL 160
181.00	C75	180		151-0322	CAP CER CP 120PF 50V J CH 160
182.00	C76	177		151-0307	CAP CER CP 0.022UF 50V ZF212
183.00	C77	177		151-0307	CAP CER CP 0.022UF 50V ZF212
184.00	C78	178		151-0298	CAP CER CP 100PF 50V J SL 212
185.00	C79	178		NOT USED	NOT USED
186.00	C80	157		151-0265	CAP CER CP 0.1UF 25V ZF 212
187.00	C81	177		151-0307	CAP CER CP 0.022UF 50V ZF212
188.00	C82	179		151-0320	CAP CER CP 68PF 50V J CH 212
189.00	C83	181		151-0323	CAP CER CP 33PF 50V K SL 212
190.00	C84	182		151-0340	CAP CER CP 5PF 50V D CH 212
191.00	C85	181		151-0323	CAP CER CP 33PF 50V K SL 212
192.00		930		NOTE#1	NOTE LINE
193.00		931		NOTE#2	NOTE LINE
194.00		932		NOTE#3	NOTE LINE

PARTS LIST

PART NO. : 837-7996

DESCRIPTION : IC BD GG MAIN EUROPE

LINE	LOCATE	DNO	OR	PART NO.	DESCRIPTION
116.00	C9 (SOLDER)	158		151-0266	CAP CER CP 0.33UF 25V Z F 3216
117.00	C10 (SOLDER)	158		151-0266	CAP CER CP 0.33UF 25V Z F 3216
118.00	C11 (SOLDER)	158		151-0266	CAP CER CP 0.33UF 25V Z F 3216
119.00	C12 (SOLDER)	157		151-0265	CAP CER CP 0.1UF 25V ZF 2125
120.00	C14	157		151-0265	CAP CER CP 0.1UF 25V ZF 2125
121.00	C15 (SOLDER)	149		151-0289	CAP CER CP 10PF 50V D CH 2125
121.10	C16 (SOLDER)	149		151-0289	CAP CER CP 10PF 50V D CH 2125
122.00	C16 (SOLDER)	176		151-0316	CAP CER CP 20PF 50V D CH 2125
123.00	C17	170	1	153-0090	CAP TANT CHIP 1UF 10V
124.00	C17	170	2	153-0086	CAP TANT CHIP 1UF 16V
125.00	C18	155		151-0264	CAP CER CP 8200PF 50V K B 2125
126.00	C19 (SOLDER)	157		151-0265	CAP CER CP 0.1UF 25V ZF 2125
127.00	C20 (SOLDER)	170	1	153-0090	CAP TANT CHIP 1UF 10V
128.00	C20 (SOLDER)	170	2	153-0086	CAP TANT CHIP 1UF 16V
129.00	C21	170	1	153-0090	CAP TANT CHIP 1UF 10V
130.00	C21	170	2	153-0086	CAP TANT CHIP 1UF 16V
131.00	C22	155		151-0264	CAP CER CP 8200PF 50V K B 2125
132.00	C23 (SOLDER)	170	1	153-0090	CAP TANT CHIP 1UF 10V
133.00	C23 (SOLDER)	170	2	153-0086	CAP TANT CHIP 1UF 16V
134.00	C24	154		151-0263	CAP CER CP 2200PF 50V K B 2125
135.00	C25	154		151-0263	CAP CER CP 2200PF 50V K B 2125
136.00	C26	154		151-0263	CAP CER CP 2200PF 50V K B 2125
137.00	C27	154		151-0263	CAP CER CP 2200PF 50V K B 2125
138.00	C28	154		151-0263	CAP CER CP 2200PF 50V K B 2125
139.00	C29	154		151-0263	CAP CER CP 2200PF 50V K B 2125
140.00	C30	154		151-0263	CAP CER CP 2200PF 50V K B 2125
141.00	C31	167		150-0313	CAP E CHIP 100UF 6.3V M
142.00	C32	169		152-0177	CAP MP 0.1UF 100V 10%
143.00	C33	159		151-0272	CAP CER 270PF 2KV SL
144.00	C34	157		151-0265	CAP CER CP 0.1UF 25V ZF 2125
145.00	C35	162		150-0307	CAP E CHIP 4.7UF 35V
146.00	C36	157		151-0265	CAP CER CP 0.1UF 25V ZF 2125
147.00	C37	166		150-0318	CAP E CHIP 68UF 6.3V
148.00	C38	157		151-0265	CAP CER CP 0.1UF 25V ZF 2125
149.00	C39	168		150-0319	CAP E CHIP 100UF 4V
150.00	C40	157		151-0265	CAP CER CP 0.1UF 25V ZF 2125
151.00	C41	157		151-0265	CAP CER CP 0.1UF 25V ZF 2125
152.00	C42	156		151-0271	CAP CER CP 0.01UF 50V ZF 2125
153.00	C43	156		151-0271	CAP CER CP 0.01UF 50V ZF 2125
154.00	C44	161		150-0317	CAP E CHIP 0.47UF 50V
155.00	C45	161		150-0317	CAP E CHIP 0.47UF 50V
156.00	C46	152		151-0270	CAP CER CP 47PF 50V K SL 2125
157.00	C47	152		151-0270	CAP CER CP 47PF 50V K SL 2125
158.00	C48	163		150-0308	CAP E CHIP 10UF 6.3V M
159.00	C49	164		150-0309	CAP E CHIP 22UF 6.3V M
160.00	C50	157		151-0265	CAP CER CP 0.1UF 25V ZF 2125
161.00	C51	157		151-0265	CAP CER CP 0.1UF 25V ZF 2125
162.00	C52	160		151-0286	CAP CER CHIP 0.47UF 16V Z F
163.00	C53	160		151-0286	CAP CER CHIP 0.47UF 16V Z F
164.00	C58 (SOLDER)	153		151-0290	CAP CER CP 1200PF 50V K B 2125
165.00	C59	151		151-0291	CAP CER CP 39PF 50V K SL 1608
166.00	C60	151		151-0291	CAP CER CP 39PF 50V K SL 1608
167.00	C61	151		151-0291	CAP CER CP 39PF 50V K SL 1608
168.00	C62	151		151-0291	CAP CER CP 39PF 50V K SL 1608
169.00	C63	151		151-0291	CAP CER CP 39PF 50V K SL 1608
170.00	C64	151		151-0291	CAP CER CP 39PF 50V K SL 1608
171.00	C65	151		151-0291	CAP CER CP 39PF 50V K SL 1608
172.00	C66	151		151-0291	CAP CER CP 39PF 50V K SL 1608

PART NO. : 837-7996

DESCRIPTION : IC BD GG MAIN EUROPE

LINE	LOCATE	DNO OR PART NO.	DESCRIPTION
56.00	R9 (SOLDER)	141 476-2474-J-10	RES CHIP 470KOHM 1/10W 5%
57.00	R10 (SOLDER)	141 476-2474-J-10	RES CHIP 470KOHM 1/10W 5%
58.00	R11	128 476-2471-J-10	RES CHIP 470 OHM 1/10W 5%
59.00	R12 (SOLDER)	133 476-2472-J-10	RES CHIP 4.7KOHM 1/10W 5%
60.00	R13	132 476-2302-J-10	RES CHIP 3KOHM 1/10W 5%
61.00	R14	126 476-2201-J-10	RES CHIP 200 OHM 1/10W 5%
62.00	R17	133 476-2472-J-10	RES CHIP 4.7KOHM 1/10W 5%
63.00	R18	134 476-2103-J-10	RES CHIP 10KOHM 1/10W 5%
64.00	R20 (SOLDER)	129 476-2102-J-10	RES CHIP 1KOHM 1/10W 5%
65.00	R21 (SOLDER)	129 476-2102-J-10	RES CHIP 1KOHM 1/10W 5%
66.00	R22 (SOLDER)	134 476-2103-J-10	RES CHIP 10KOHM 1/10W 5%
67.00	R23 (SOLDER)	129 476-2102-J-10	RES CHIP 1KOHM 1/10W 5%
68.00	R24 (SOLDER)	129 476-2102-J-10	RES CHIP 1KOHM 1/10W 5%
69.00	R25 (SOLDER)	134 476-2103-J-10	RES CHIP 10KOHM 1/10W 5%
70.00	R26	138 476-2473-J-10	RES CHIP 47KOHM 1/10W 5%
71.00	R27	138 476-2473-J-10	RES CHIP 47KOHM 1/10W 5%
72.00	R28	910 NOT USED	NOT USED
73.00	R29	130 476-2182-J-10	RES CHIP 1.8KOHM 1/10W 5%
74.00	R30	130 476-2182-J-10	RES CHIP 1.8KOHM 1/10W 5%
75.00	R31	139 476-2104-J-10	RES CHIP 100KOHM 1/10W 5%
76.00	R32	139 476-2104-J-10	RES CHIP 100KOHM 1/10W 5%
77.00	R33	172 476-2303-J-10	RES CHIP 30KOHM 1/10W 5%
78.00	R34	135 476-2203-J-10	RES CHIP 20KOHM 1/10W 5%
79.00	R35	125 476-2510-J-10	RES CHIP 51 OHM 1/10W 5%
80.00	R36	148 476-2563-F-10	RES CHIP 56KOHM 1/10W 1%
81.00	R37	146 476-2303-F-10	RES CHIP 30KOHM 1/10W 1%
82.00	R38	125 476-2510-J-10	RES CHIP 51 OHM 1/10W 5%
83.00	R39	143 476-2471-F-10	RES CHIP 470 OHM 1/10W 1%
84.00	R40	143 476-2471-F-10	RES CHIP 470 OHM 1/10W 1%
85.00	R41	131 476-2222-J-10	RES CHIP 2.2KOHM 1/10W 5%
86.00	R42	140 476-2244-J-10	RES CHIP 240KOHM 1/10W 5%
87.00	R43	136 476-2223-J-10	RES CHIP 22KOHM 1/10W 5%
88.00	R44	136 476-2223-J-10	RES CHIP 22KOHM 1/10W 5%
89.00	R45	142 476-2105-J-10	RES CHIP 1MOHM 1/10W 5%
90.00	R46	136 476-2223-J-10	RES CHIP 22KOHM 1/10W 5%
91.00	R47	136 476-2223-J-10	RES CHIP 22KOHM 1/10W 5%
92.00	R48 (SOLDER)	134 476-2103-J-10	RES CHIP 10KOHM 1/10W 5%
93.00	R49 (SOLDER)	134 476-2103-J-10	RES CHIP 10KOHM 1/10W 5%
94.00	R50	174 476-2912-F-10	RES CHIP 9.1KOHM 1/10W 1%
95.00	R51	173 476-2112-F-10	RES CHIP 1.1KOHM 1/10W 1%
96.00	R52	175 476-2302-F-10	RES CHIP 3KOHM 1/10W 1%
97.00	R53 (SOLDER)	171 476-2122-J-10	RES CHIP 1.2KOHM 1/10W 5%
98.00	R54	127 476-2221-J-10	RES CHIP 220 OHM 1/10W 5%
99.00	R55	127 476-2221-J-10	RES CHIP 220 OHM 1/10W 5%
100.00	R56	127 476-2221-J-10	RES CHIP 220 OHM 1/10W 5%
101.00	R57	127 476-2221-J-10	RES CHIP 220 OHM 1/10W 5%
102.00	R58	127 476-2221-J-10	RES CHIP 220 OHM 1/10W 5%
103.00	R59	127 476-2221-J-10	RES CHIP 220 OHM 1/10W 5%
104.00	R60 (SOLDER)	127 476-2221-J-10	RES CHIP 220 OHM 1/10W 5%
105.00	R61 (SOLDER)	127 476-2221-J-10	RES CHIP 220 OHM 1/10W 5%
106.00	R62 (SOLDER)	127 476-2221-J-10	RES CHIP 220 OHM 1/10W 5%
107.00	R63 (SOLDER)	127 476-2221-J-10	RES CHIP 220 OHM 1/10W 5%
108.00	R64	910 NOT USED	NOT USED
109.00	C1	165 150-0311	CAP E CHIP 33UF 6.3V M
110.00	C3	163 150-0308	CAP E CHIP 10UF 6.3V M
111.00	C4	157 151-0265	CAP CER CP 0.1UF 25V ZF 212
112.00	C5	157 151-0265	CAP CER CP 0.1UF 25V ZF 212
113.00	C6	163 150-0308	CAP E CHIP 10UF 6.3V M
114.00	C7	157 151-0265	CAP CER CP 0.1UF 25V ZF 212
115.00	C8 (SOLDER)	158 151-0266	CAP CER CP 0.33UF 25V Z F 321

PART NO. : 837-7996

DESCRIPTION : IC BD GG MAIN EUROPE

LINE	LOCATE	DNO	OR	PART NO.	DESCRIPTION
1.00		1		171-6101A	PC BD GG MAIN EUROPE
2.00	IC1	101		315-0545	IC Z80A C-MOS SOP TMP84C00AM
3.00	IC2	102		315-5377	IC CUSTOM CHIP VDP GG QFP
4.00	IC3	103		315-5378A	IC CUSTOM CHIP SCA GG QFP
5.00	IC4	104	1	315-0546	IC UPD4364G-15L SOP 28P
6.00	IC4	104	2	315-0611	IC FCB61C651-70T SOP 28P
7.00	IC5 (SOLDER)	105		315-0547	IC HM65256BLEP-12 SOP 28P
8.00	IC6 (SOLDER)	106		313-5134	IC UPC358G2 SOP 8P
9.00	Q1	108		482-5126	XSTR 2SC1623 L5..7 CHIP
10.00	Q2	910		NOT USED	NOT USED
11.00	Q3 (SOLDER)	109		482-5127	XSTR 2SD1614 CHIP
12.00	Q4 (SOLDER)	109		482-5127	XSTR 2SD1614 CHIP
13.00	Q5	108		482-5126	XSTR 2SC1623 L5..7 CHIP
14.00	Q6	108		482-5126	XSTR 2SC1623 L5..7 CHIP
15.00	Q7	108		482-5126	XSTR 2SC1623 L5..7 CHIP
16.00	Q8	107		482-5125	XSTR 2SA812 M5..7 CHIP
17.00	Q9	108		482-5126	XSTR 2SC1623 L5..7 CHIP
18.00	Q10	107		482-5125	XSTR 2SA812 M5..7 CHIP
19.00	Q11	108		482-5126	XSTR 2SC1623 L5..7 CHIP
20.00	FB1	910		NOT USED	NOT USED
21.00	LD1 (SOLDER)	110		390-5308	LED SLR 34-VT3F
22.00	D1	111		481-5072	DIODE 1SS184 CHIP
23.00	D2	111		481-5072	DIODE 1SS184 CHIP
24.00	D3	111		481-5072	DIODE 1SS184 CHIP
25.00	D4	111		481-5072	DIODE 1SS184 CHIP
26.00	X1	112		230-5066	XTAL OSC 32.215905M 100PPM
27.00	CN1	113		209-5037	CONN 45P FOR GG-0-176914-J
27.10	CN1	113		209-5037-01	CONN 45P FOR GG 01
28.00	CN2	114		209-5038	CONN 10P FOR GG HDC-0492
29.00	CN3	115		209-5039	CHANGE TO 212-5304
30.00	CN4	116		209-5041	CHANGE TO 212-5305
30.10	CN3	115		212-5304	CONN 6P FOR GG 178094-6
30.20	CN4	116		212-5305	CONN 9P FOR GG 178094-9
31.00	FU1	117		514-5040	FUSE THERMAL SMO95B0
32.00	FU2	117		514-5040	FUSE THERMAL SMO95B0
33.00	1	118		048-0001	EYLET 3.5*7
34.00	2	118		048-0001	EYLET 3.5*7
35.00	EM1	119		271-0007	EMI FILTER STX222MB
36.00	EM2	119		271-0007	EMI FILTER STX222MB
37.00	EM3	119		271-0007	EMI FILTER STX222MB
38.00	EM4	119		271-0007	EMI FILTER STX222MB
39.00	EM5	119		271-0007	EMI FILTER STX222MB
40.00	EM6	119		271-0007	EMI FILTER STX222MB
41.00	EM7	119		271-0007	EMI FILTER STX222MB
42.00	EM8	119		271-0007	EMI FILTER STX222MB
43.00	L1	120		271-0017	BEADS INDUCTOR FBA04VA900AB-1
44.00	L3	121		180-5073	P.COIL CHIP 100UH LEM4532T10
45.00	L2	122		180-5077	CHOKE COIL 105UH KI-1589
46.00	T1	123		560-5172	INVERTER XFMR KI-1588
47.00	VR1	124		220-5339	VOL CONT 20KB RK09J11TO
48.00	R1	133		476-2472-J-10	RES CHIP 4.7KOHM 1/10W 5%
49.00	R2	133		476-2472-J-10	RES CHIP 4.7KOHM 1/10W 5%
50.00	R3 (SOLDER)	133		476-2472-J-10	RES CHIP 4.7KOHM 1/10W 5%
51.00	R4 (SOLDER)	133		476-2472-J-10	RES CHIP 4.7KOHM 1/10W 5%
52.00	R5 (SOLDER)	133		476-2472-J-10	RES CHIP 4.7KOHM 1/10W 5%
53.00	R6 (SOLDER)	133		476-2472-J-10	RES CHIP 4.7KOHM 1/10W 5%
54.00	R7 (SOLDER)	141		476-2474-J-10	RES CHIP 470KOHM 1/10W 5%
55.00	R8 (SOLDER)	141		476-2474-J-10	RES CHIP 470KOHM 1/10W 5%

GAME GEAR

EUROPE

PARTS LIST OF PCB

TDA2822M

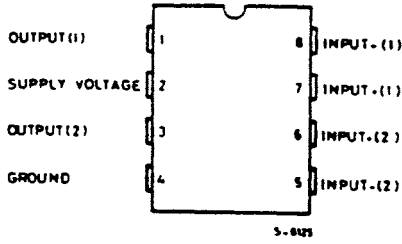

SCHEMATIC DIAGRAM

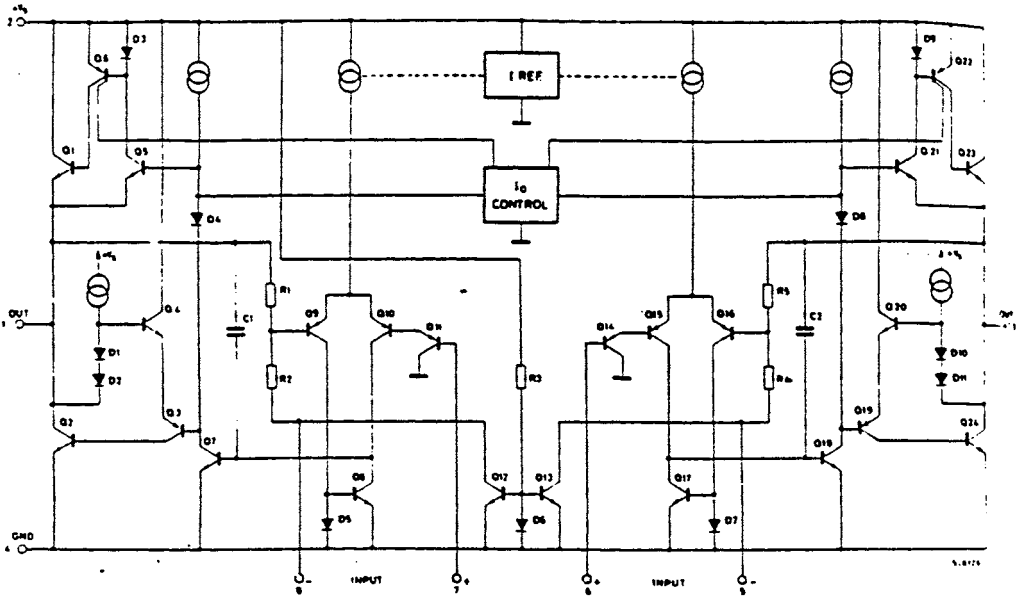

8 lead Plastic Minidip
4 + 4 lead Powerdip

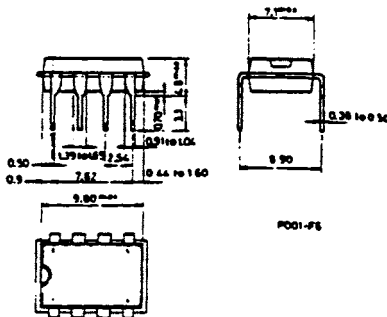

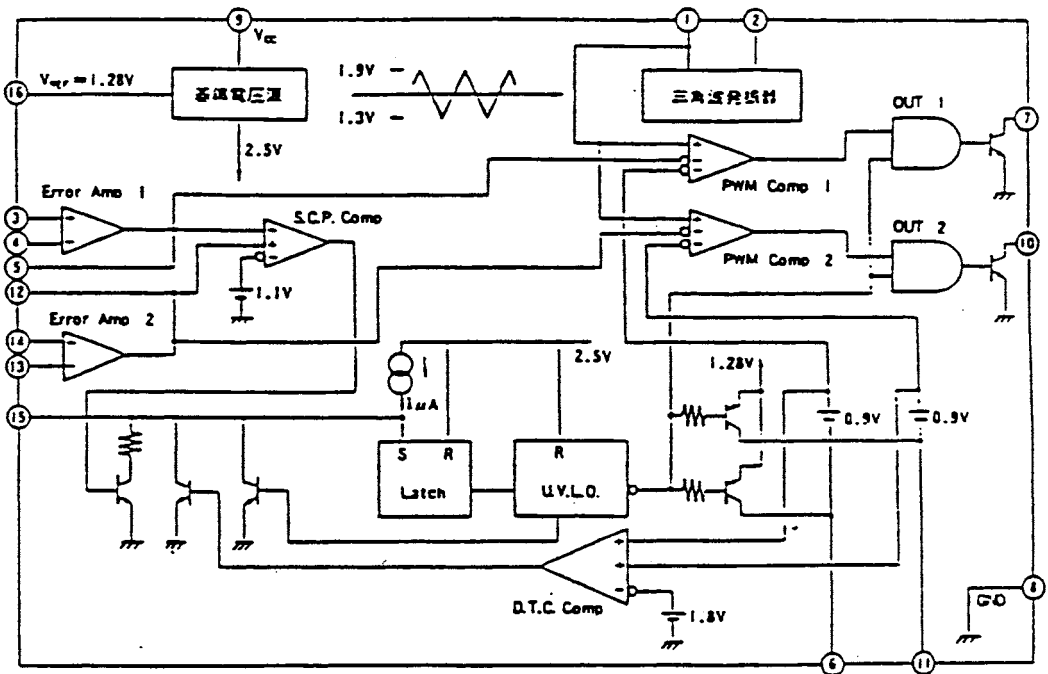
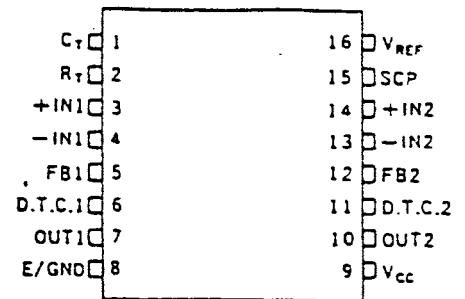
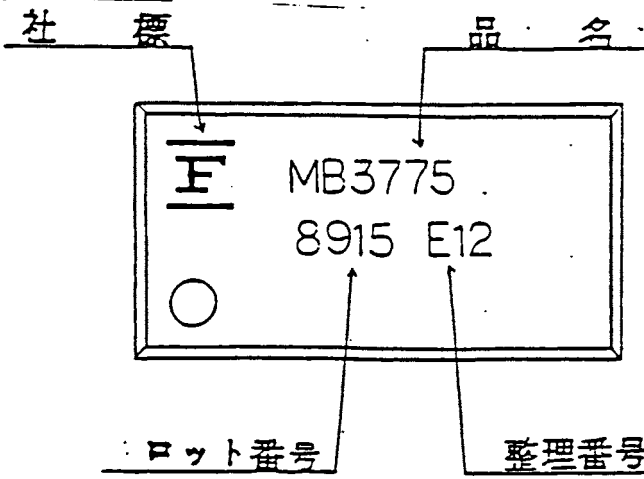

プラスチック・SOP, 16ピン
(FPT-16P-M02)

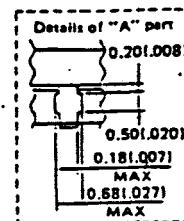
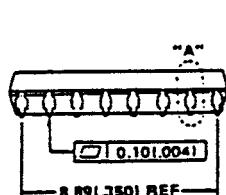
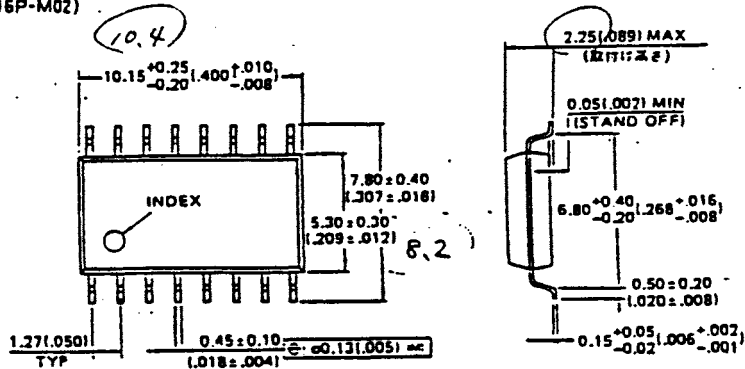

單位: mm (inches)

MAIN BOARD IC4 1/1
IC uPD4364G-15L

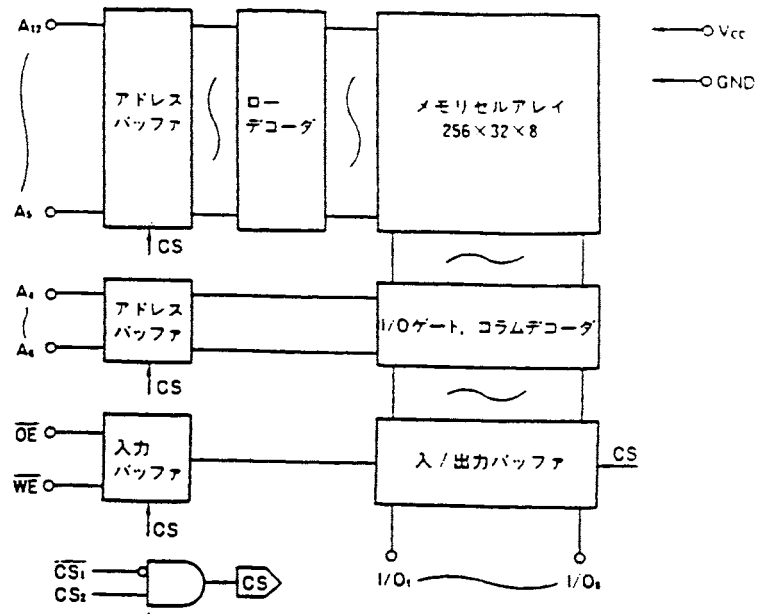
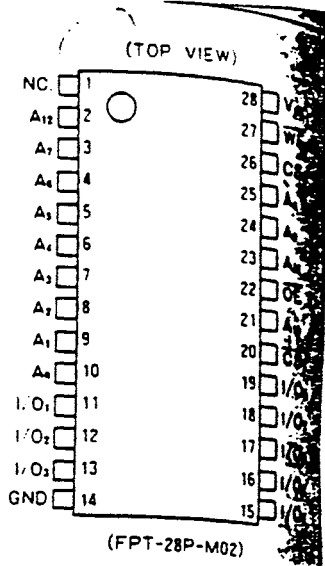

(FPT-28P-M02)

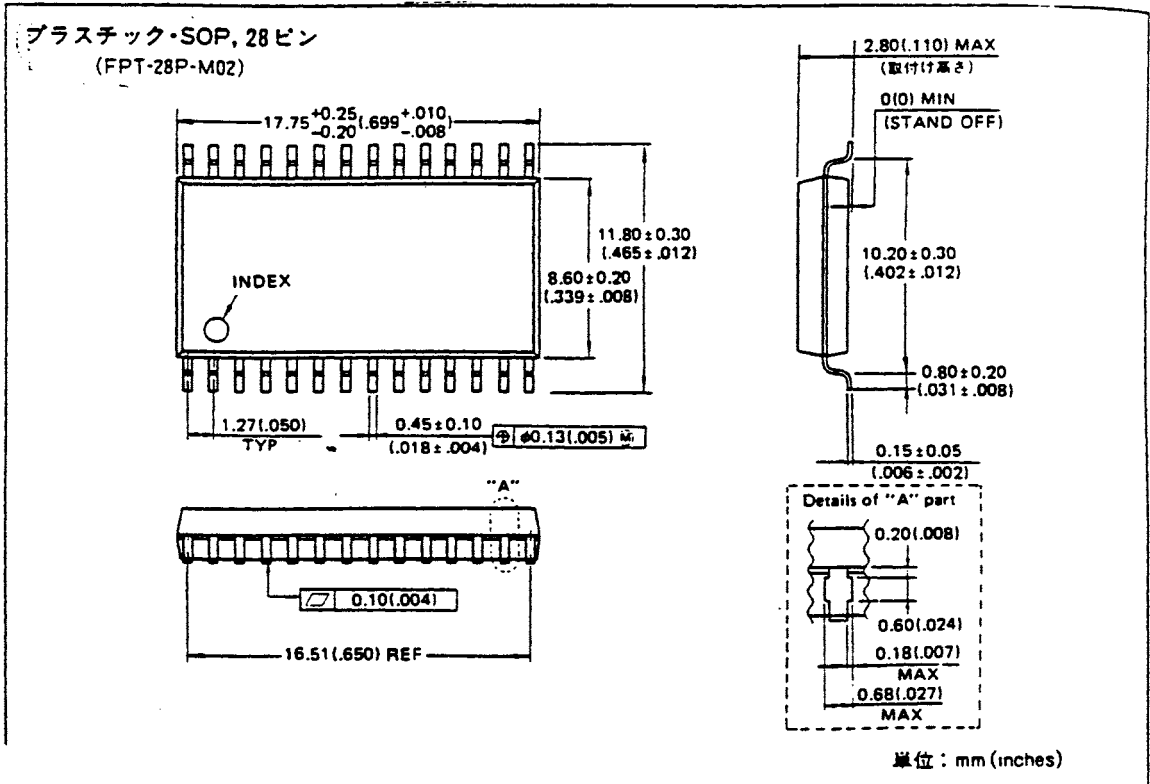

μPC1251/358

電子回路 (Top View)

μPC1251D, 1251C, 1251G
μPC358C, 358G

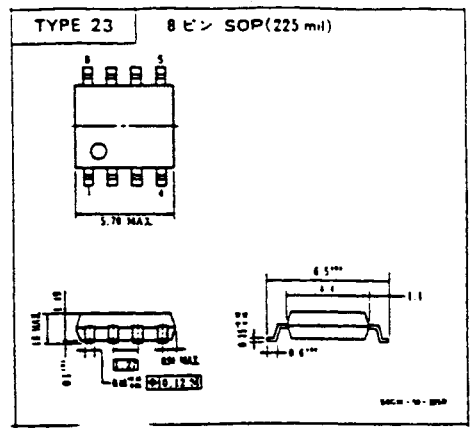
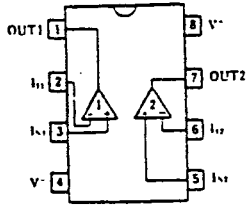

MAIN BOARD IC5 1/1
IC HM6256BLFP-12

■ピン配置

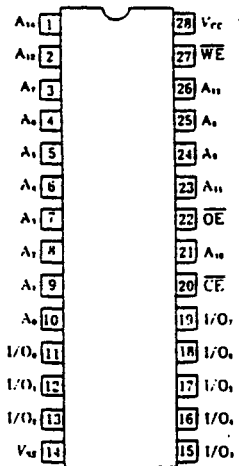

■ブロックダイアグラム

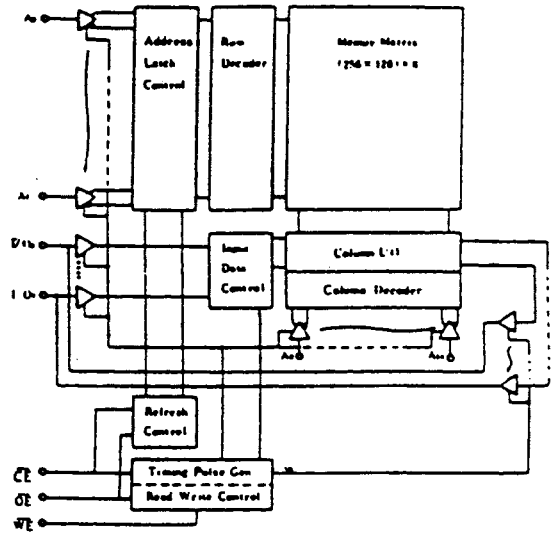

FP-28DA

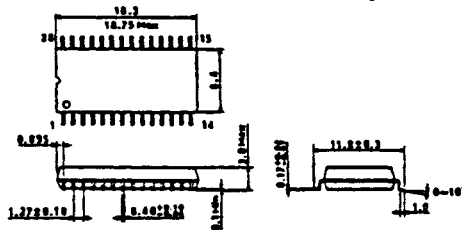
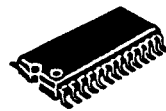

マーキング方法

SEGA

315-5378B

ワット

PIN ASSIGN (TOP VIEW)

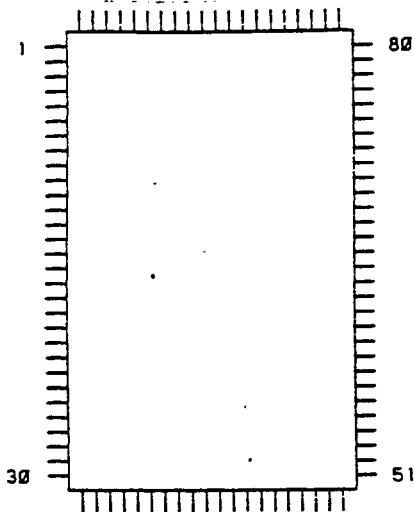

PIN NO.	PIN NAME	PIN NO.	PIN NAME	PIN NO.	PIN NAME	PIN NO.	PIN NAME
1	GND	26	RESO	51	DW	76	PC4
2	VDD	27	NLED	52	VDD	77	PC5
3	XTL1	28	GND	53	GND	78	PC6
4	XTL2	29	VDD	54	CLB1	79	VDD
5	CCLK	30	VREF	55	CLA1	80	GND
6	VCLK	31	VONF	56	CLB2	81	D7D
7	NUP	32	VRES	57	CLA2	82	D6D
8	NDW	33	SNDN	58	CLB3	83	D5C
9	NLE	34	SND3	59	CLA3	84	D4P
10	NR1	35	SND2	60	TPR1	85	D3P
11	NTL	36	SND1	61	TPR2	86	D2P
12	NTR	37	SNDL	62	A	87	D1P
13	NPS	38	SNDR	63	SAMP	88	D0D
14	CPA0	39	TEST	64	NLCD	89	AAR2
15	CPA1	40	GND	65	NTV	90	A9R1
16	CPA2	41	DB	66	NGG	91	A8A3
17	CPA3	42	P3	67	NNM1	92	A7B3
18	CPB	43	P2	68	NM1	93	A6A2
19	NTSC	44	P4	69	IORQ	94	A5B2
20	H488	45	P1	70	NWR	95	A4A1
21	HBNK	46	CL2	71	NRD	96	A3B1
22	VBNK	47	DO2	72	PC0	97	A2DW
23	NHL	48	DO4	73	PC1	98	A1D3
24	NJAP	49	DO1	74	PC2	99	A0D1
25	SPON	50	DO3	75	PC3	100	XCLK

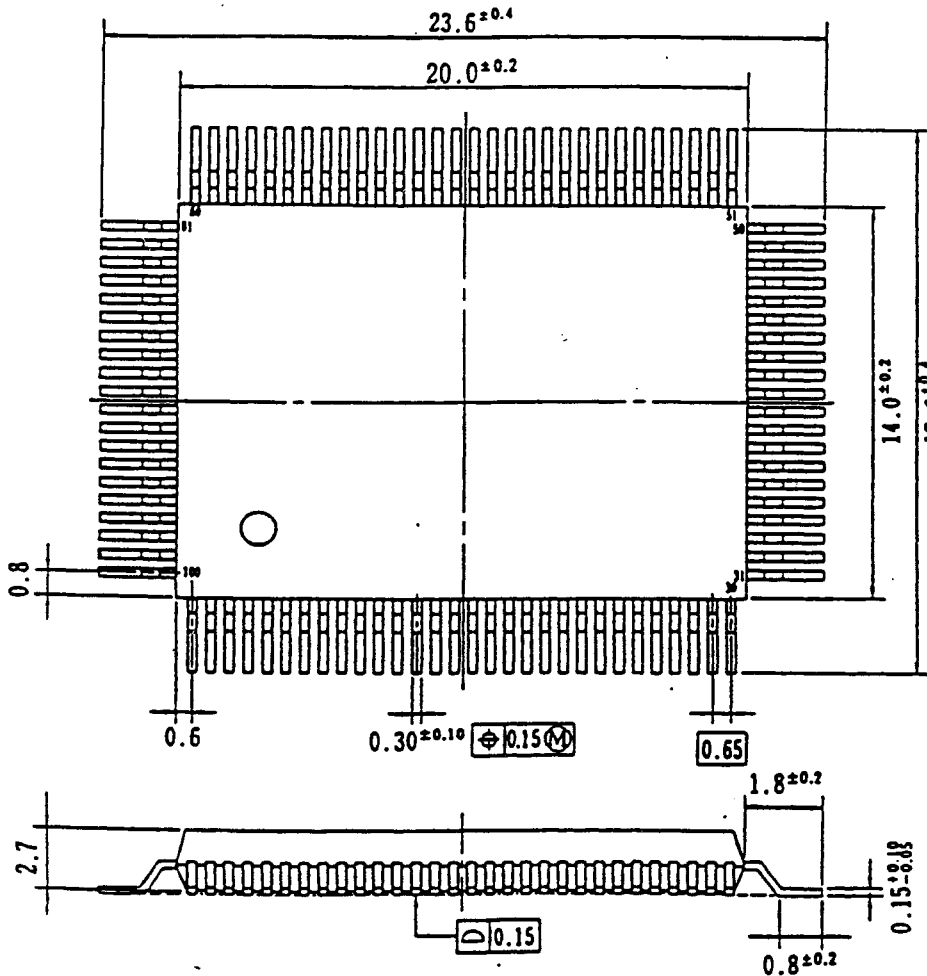

端子先端形状詳細図

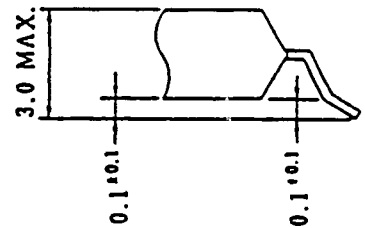

IC CUSTAM VDP

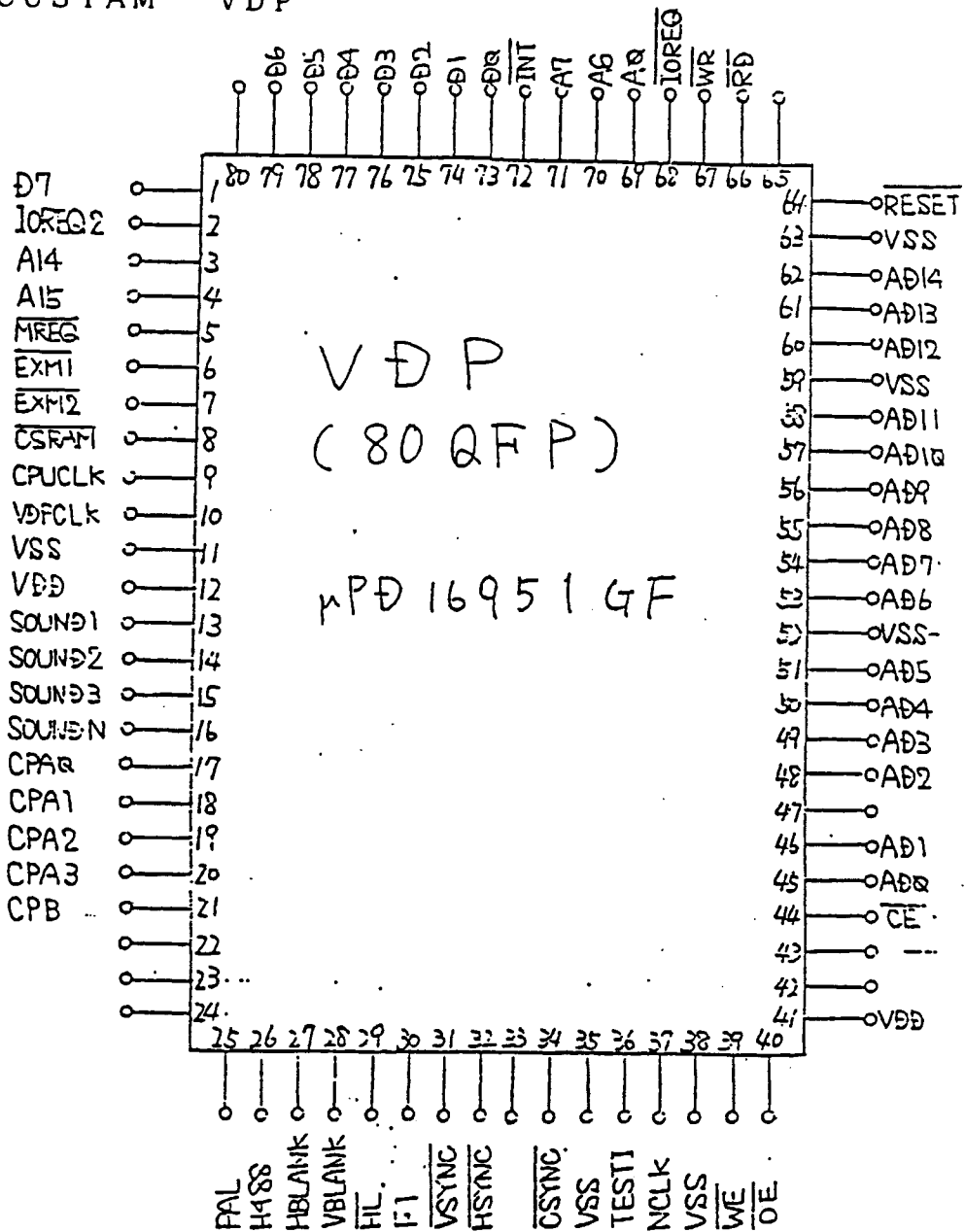

80 Pin Plastic FLAT

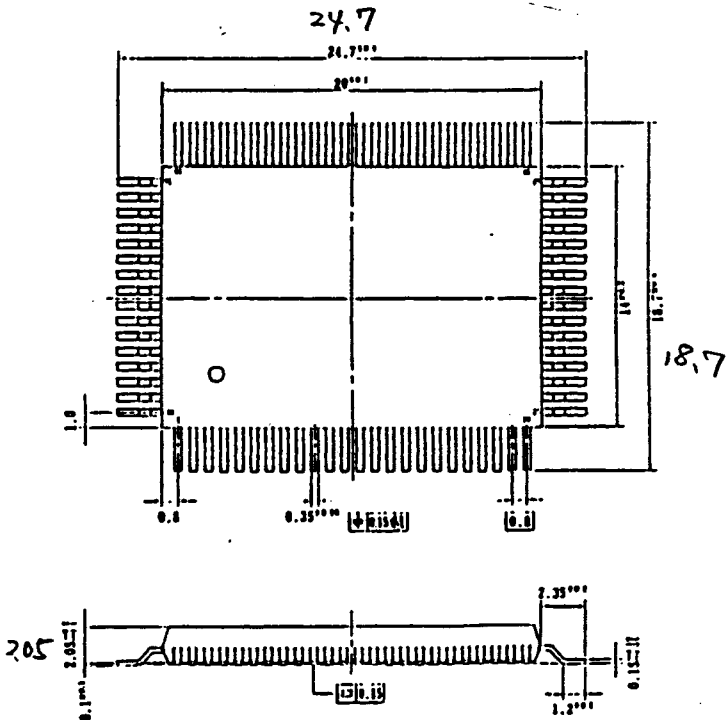

PARTS LIST

PART NO. : 837-7998
 DESCRIPTION : IC BD GG SOUND EUROPE

LINE	LOCATE	DNO	OR	PART NO.	DESCRIPTION
1.00		1		171-6103A	PC BD GG SOUND EUROPE
2.00	J1	102		210-5061	CONN MINI JACK HSJ0873-01-110
3.00	CN1	103		600-5910	WIRE HARN 6P FOR GG GOMM
4.00	CN2	104		209-5040	CHANGE TO 212-5301-02
4.10	CN2	104		212-5301-02	CONN M MT AMP CT 2P 173981-2
5.00	VR1	105		220-5343	SW VOL CONT 10KOHM K102JOZ25
6.00	IC1	101		313-5141	IC TDA2822M
7.00	R1	108		476-2563-J-10	RES CHIP 56KOHM 1/10W 5%
8.00	R2	108		476-2563-J-10	RES CHIP 56KOHM 1/10W 5%
9.00	R3	106		476-24R7-J-10	RES CHIP 4.7 OHM 1/10W 5%
10.00	R4	106		476-24R7-J-10	RES CHIP 4.7 OHM 1/10W 5%
11.00	R5	107		476-2101-J-10	RES CHIP 100 OHM 1/10W 5%
12.00	R6	107		476-2101-J-10	RES CHIP 100 OHM 1/10W 5%
13.00	C1	111		150-0313-01	CAP E CP 100UF 6.3V MV6.3VC10
14.00	C2	111		150-0313-01	CAP E CP 100UF 6.3V MV6.3VC10
15.00	C3	111		150-0313-01	CAP E CP 100UF 6.3V MV6.3VC10
16.00	C4	109		151-0265	CAP CER CP 0.1UF 25V ZF 212
17.00	C5	110		150-0312-01	CAP E CP 47UF 4V MV4VC47
18.00	C6	109		151-0265	CAP CER CP 0.1UF 25V ZF 212
19.00	C7	110		150-0312-01	CAP E CP 47UF 4V MV4VC47
20.00	C8	109		151-0265	CAP CER CP 0.1UF 25V ZF 212
21.00	LF1	112		270-5044	LINE FILTER(SDP-103C)

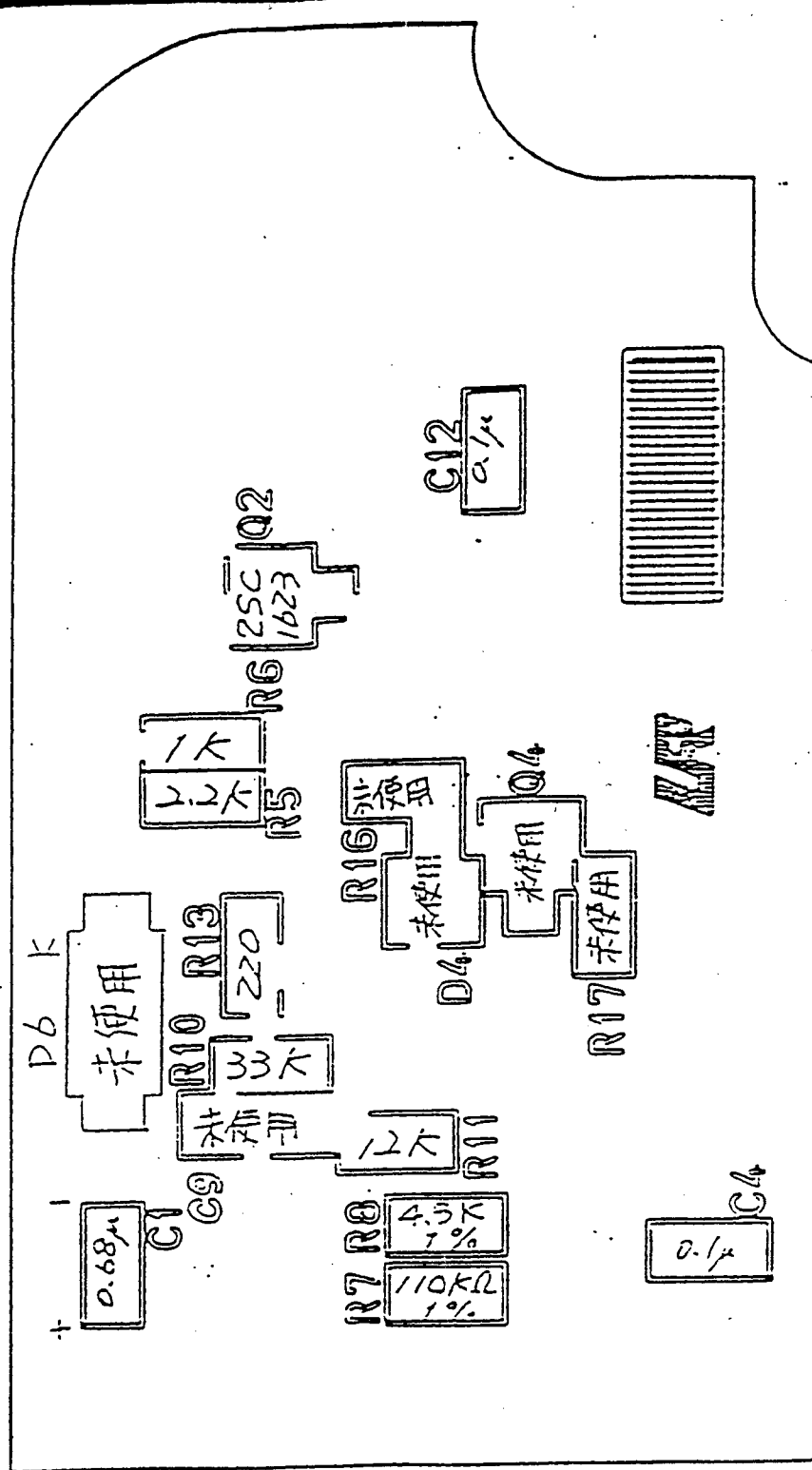

Sold Side 部品面視半田面

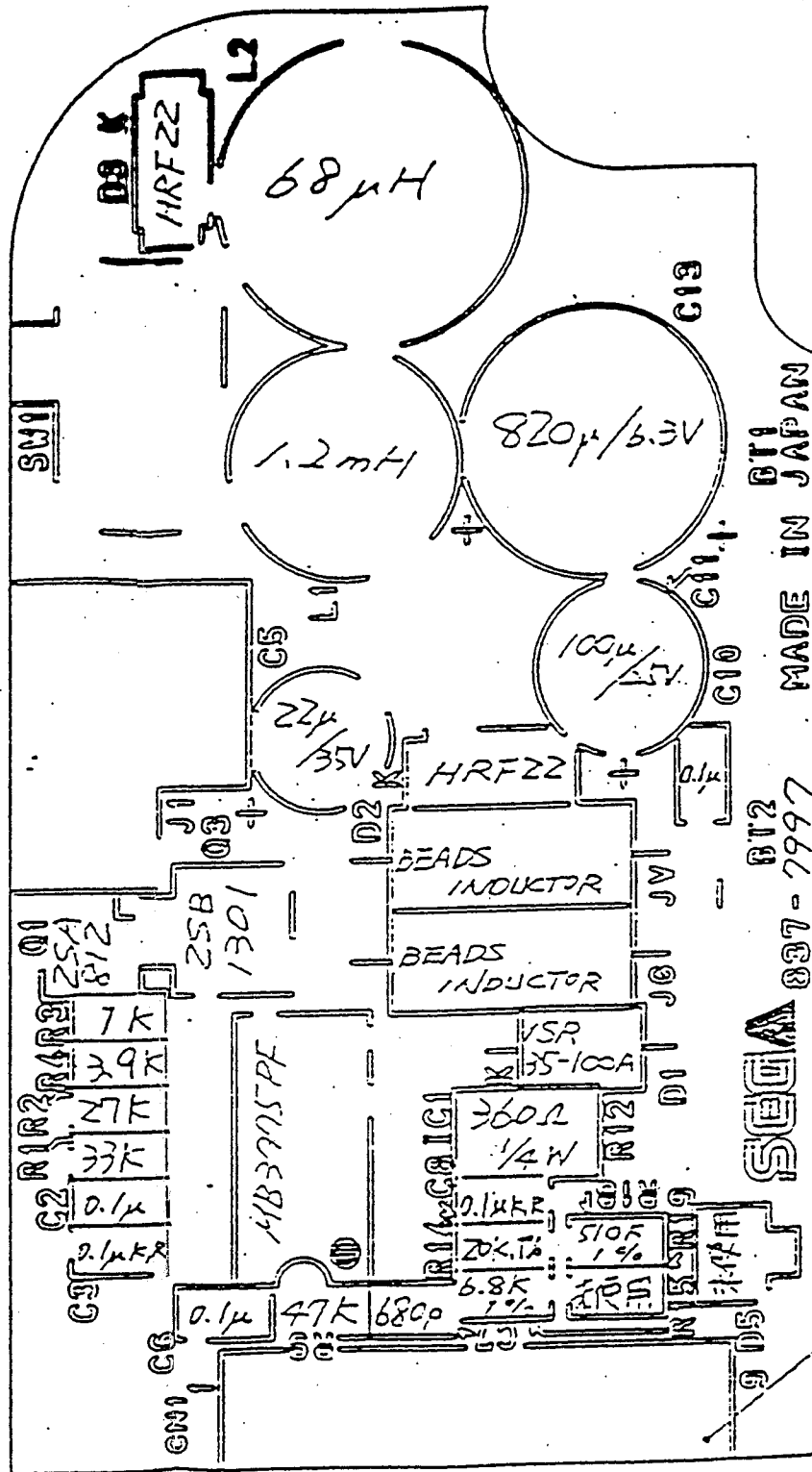

部品面視部品面 Comp Side

MACHINE 機名	SUB-ASS'Y 組立番
	837-79958
ALTERATIONS 改訂	

MADE IN JAPAN
 BT1
 BT2
 BT3
 BT4
 BT5
 BT6
 BT7
 BT8
 BT9
 BT10
 BT11
 BT12
 BT13
 BT14
 BT15
 BT16
 BT17
 BT18
 BT19
 BT20
 BT21
 BT22
 BT23
 BT24
 BT25
 BT26
 BT27
 BT28
 BT29
 BT30
 BT31
 BT32
 BT33
 BT34
 BT35
 BT36
 BT37
 BT38
 BT39
 BT40
 BT41
 BT42
 BT43
 BT44
 BT45
 BT46
 BT47
 BT48
 BT49
 BT50
 BT51
 BT52
 BT53
 BT54
 BT55
 BT56
 BT57
 BT58
 BT59
 BT60
 BT61
 BT62
 BT63
 BT64
 BT65
 BT66
 BT67
 BT68
 BT69
 BT70
 BT71
 BT72
 BT73
 BT74
 BT75
 BT76
 BT77
 BT78
 BT79
 BT80
 BT81
 BT82
 BT83
 BT84
 BT85
 BT86
 BT87
 BT88
 BT89
 BT90
 BT91
 BT92
 BT93
 BT94
 BT95
 BT96
 BT97
 BT98
 BT99
 BT100

837-7997B(7/3)

SEGA SEGA ENTERPRISES, LTD.		THIS DRAWING WILL IN NO WAY BE COPIED, TO BE RETURNED ON DEMAND.		許可なく複写複製等は禁断	
LIMITS UNLESS OTHERWISE SPECIFIED 一般公差		3RD QUAT. PROJ. DRAWING 第三角法		設計-製図	検図
		SCALE 尺法	X		
		DIM. IN 単位	mm	1/5本	
MATERIAL 材料	HEAT TREAT. 熱処理	FINISH 表面処理	REMARK 特殊指示	REV.	
IC BD 0A DC-DC CONU. EUROPE (A/B)			837-7997B (7/3)		
DESCRIPTION 名称			PART NO. 図番・部品番号		

108

MACHINE 機名	SUB-ASS'Y. 組立番
	837-7995
ALTERATIONS 改訂	

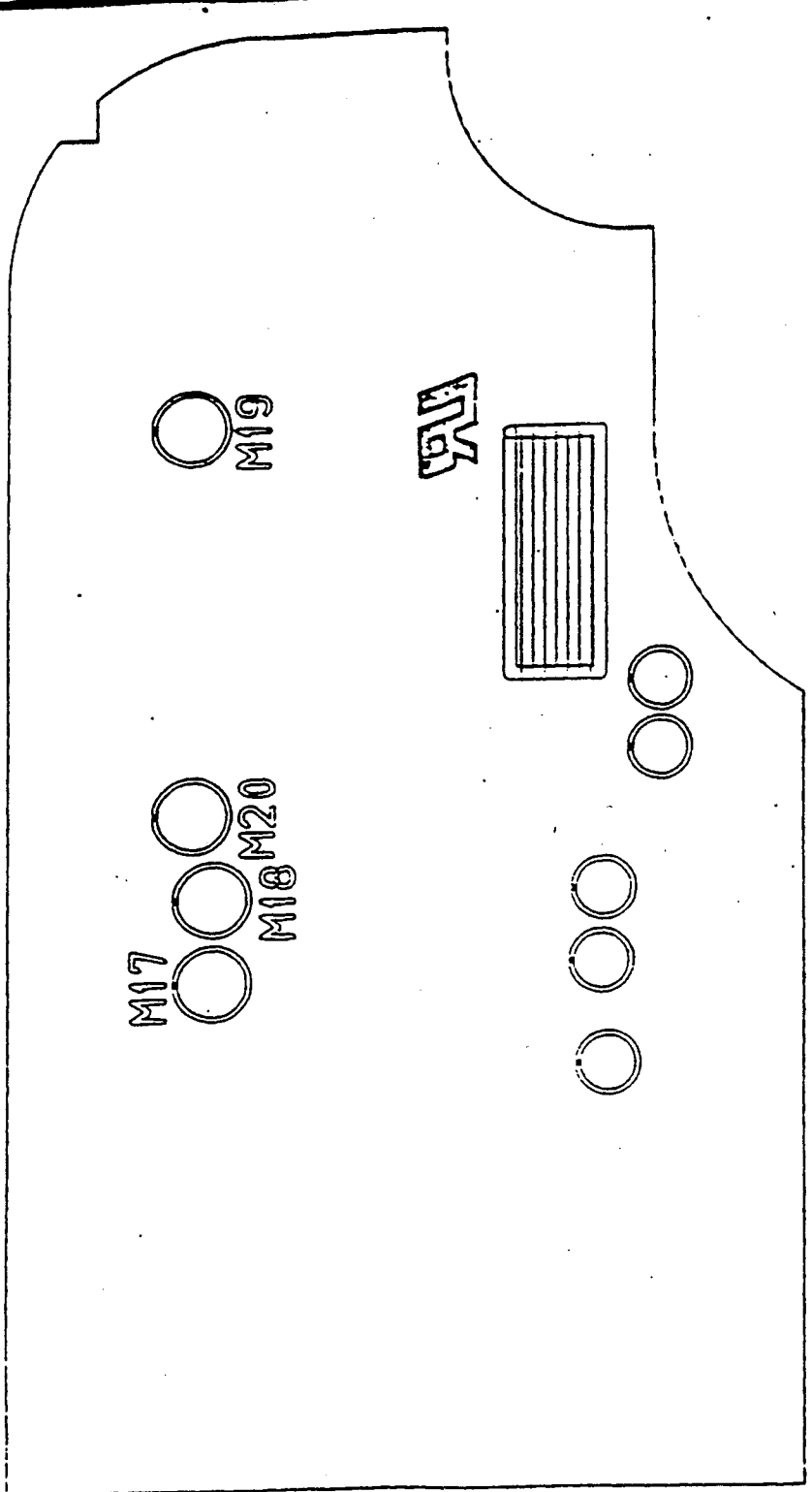

Sold Side 半田面視 半田面

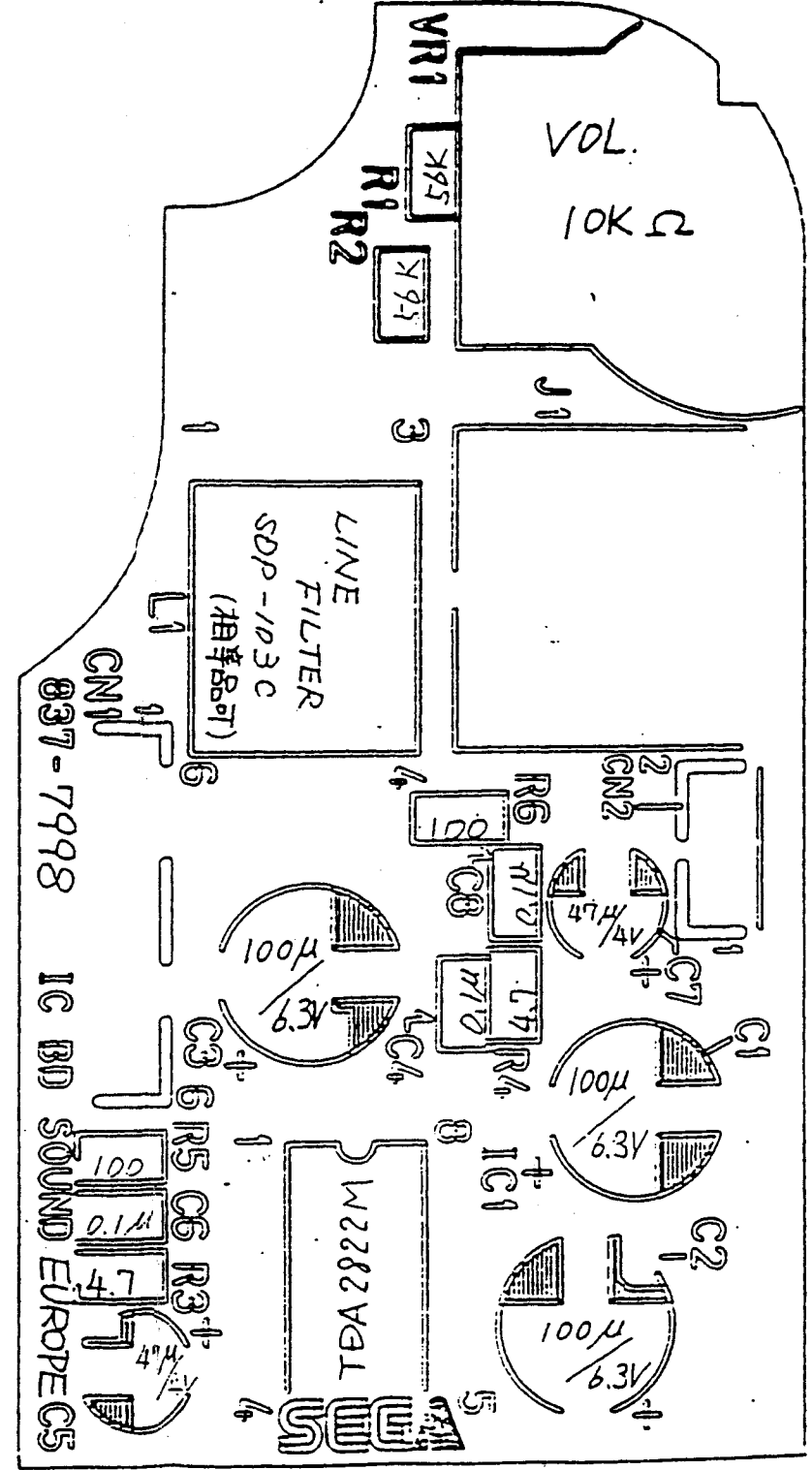

部品面視 部品面 Comp Side

837-7998 (73)

SEGA SEGA ENTERPRISES, LTD.		THIS DRAWING WILL IN NO WAY BE COPIED, TO BE RETURNED ON DEMAND.		許可なく複写 複製等は禁	
LIMITS UNLESS OTHERWISE SPECIFIED 一以之準		3RD QUAT PROJ. DRAWING 第三角法		設計 松本	承認 永
		SCALE 尺法	X	松本 大場	永
		DIM. IN 単位	mm	5/8-'91 5/9-'91	5/9-'91
MATERIAL 材料	HEAT TREAT. 熱処理	FINISH 表面処理	REMARK 特殊指示	REV.	
IC BD 818 SOUND EUROPE			837-7998 (7/3)		
DESCRIPTION 名称			PART NO. 部品番		

A B C D E F

1
2
3
4
5
6

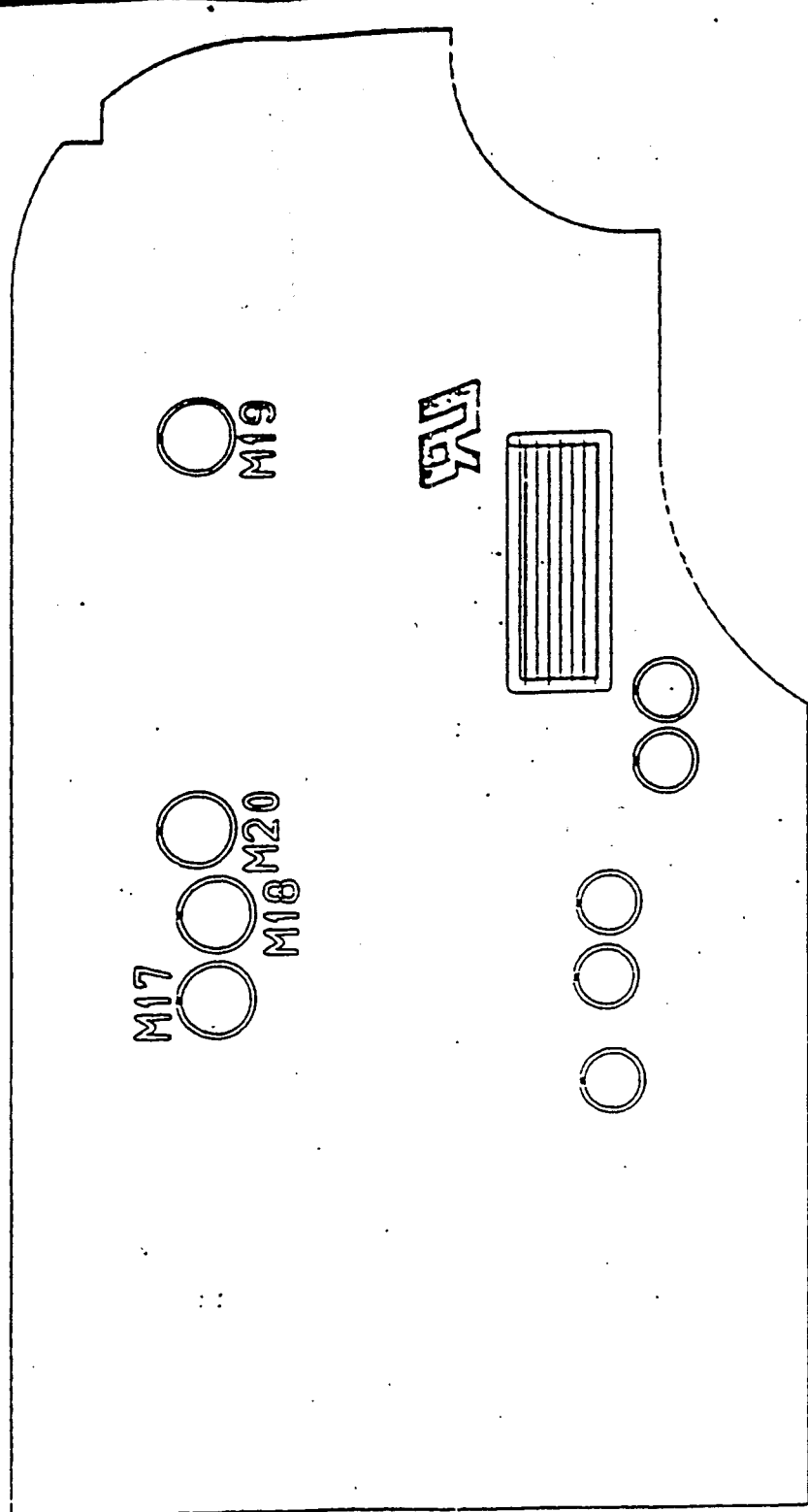

Sold Side 半田面視半田面

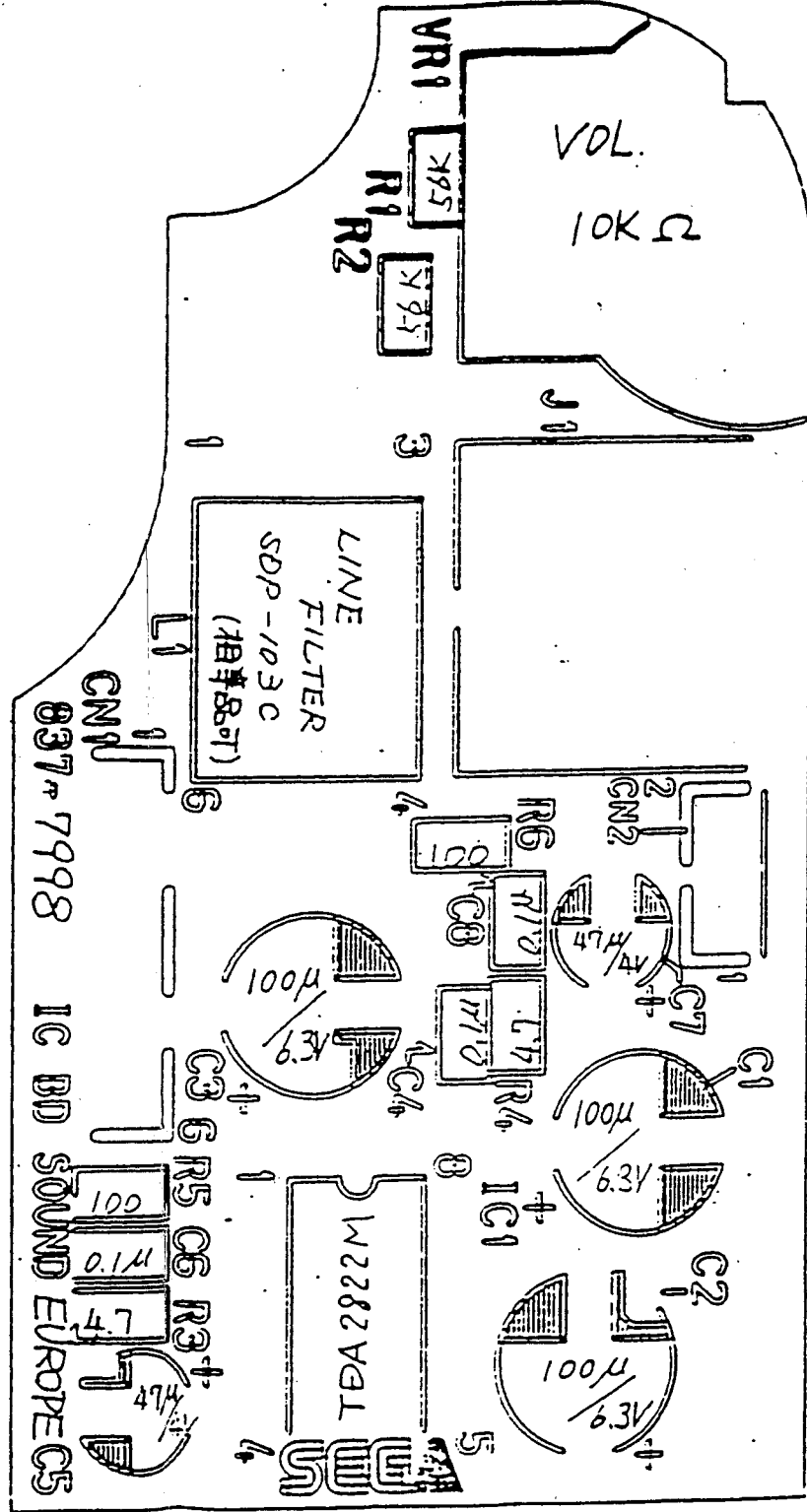

部品面視部品面 Comp Side

MACHINE 機名	SUB-ASSY. 組立番
	837-7995B
ALTERATIONS 改訂	

SEGA SEGA ENTERPRISES, LTD.		THIS DRAWING WILL IN NO WAY BE COPIED, TO BE RETURNED ON DEMAND.		許可なく複写複製等厳禁	
LIMITS UNLESS OTHERWISE SPECIFIED 一般公差		3RD QUAT. PROJ. DRAWING 第三角法	設計製図	検図	検記
		SCALE 尺法	X		
		DIM. IN 単位	mm	松本	
MATERIAL 材料	HEAT TREAT. 熱処理	FINISH 表面処理	REMARK 特殊指示	REV.	
IC BD 8A SOUND EUROPE (SCA B)			837-7998B (2/3)		
DESCRIPTION 名称			PART NO. 図番・部品番号		

837-7998B(2/3)

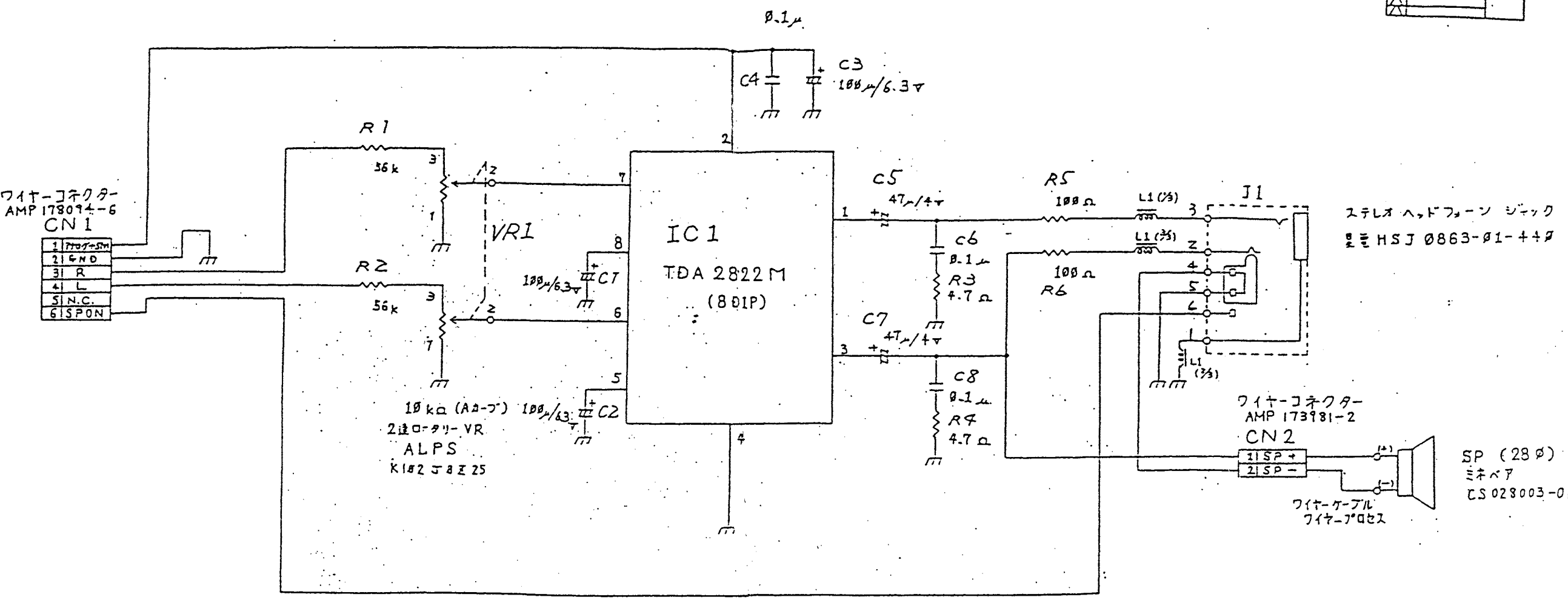
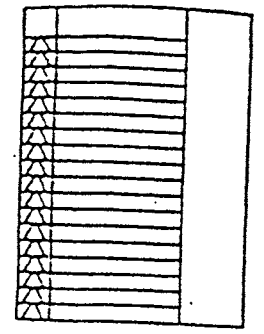

IC BD 0A SOUND EUROPE B 837-7998 05-5375 0A
 IC BD 0A SOUND EUROPE 837-7998 05-5375 0A

SEGA SEGA ENTERPRISES, LTD.	APL	
THIS DRAWING WILL IN NO WAY BE CONSIDERED TO BE RETURNED OR REPRODUCED WITHOUT THE WRITTEN PERMISSION OF SEGA.	ASST	
	CHK	
	REV. CH	
PC CD 0A SOUND EUROPE	REV	
	171-6102A	
DESCRIPTION	PART	QTY
	001	1

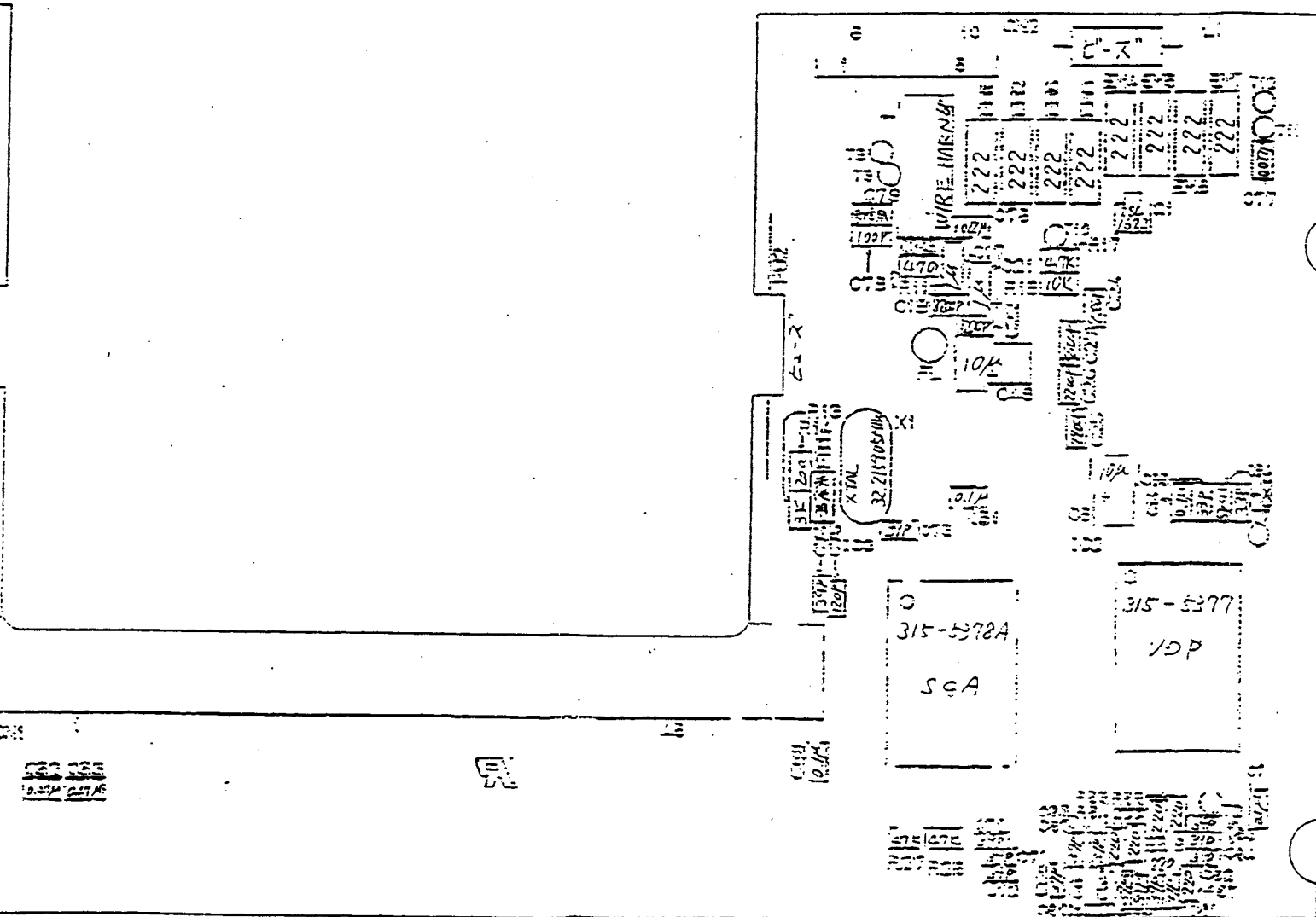
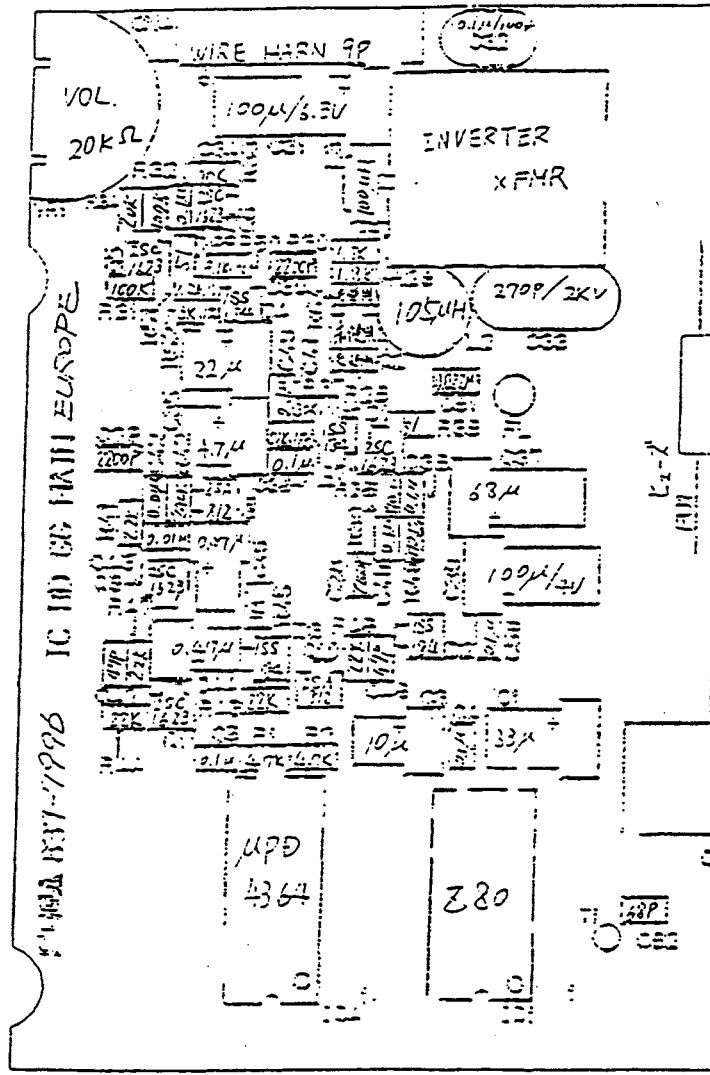

3D 03 03 MAIN EUROPE

MACHINE	MMT	SUB-ASSY	MMT
		P37-7995	
ALTERATIONS			

Comp Side

SEGA SEGA ENTERPRISES, LTD.		THIS DRAWING WILL BE MADE BY COPYING OR BY REPRODUCING ON DEMAND.		REVISIONS	
LIMITS UNLESS OTHERWISE SPECIFIED		DWD QUAT PROJ DRAWING NUMBER		REV	
		SCALE		REVISIONS	
		DIM IN MM		REV	
MATERIAL		HEAT TREAT		FINISH	
IC 3D 03 MAIN EUROPE				REMARK	
DESCRIPTION				PART NO.	
				P37-7995 (92)	

MACHINE NO.	SUB-ASSY NO.
	837-7995
ALTERATIONS	

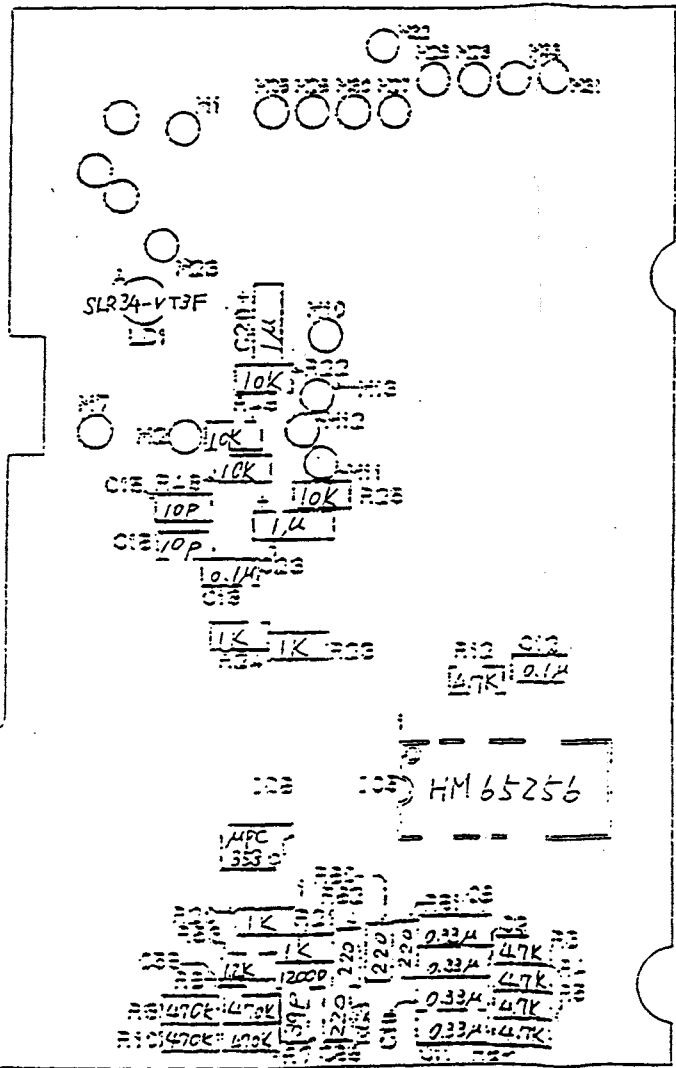
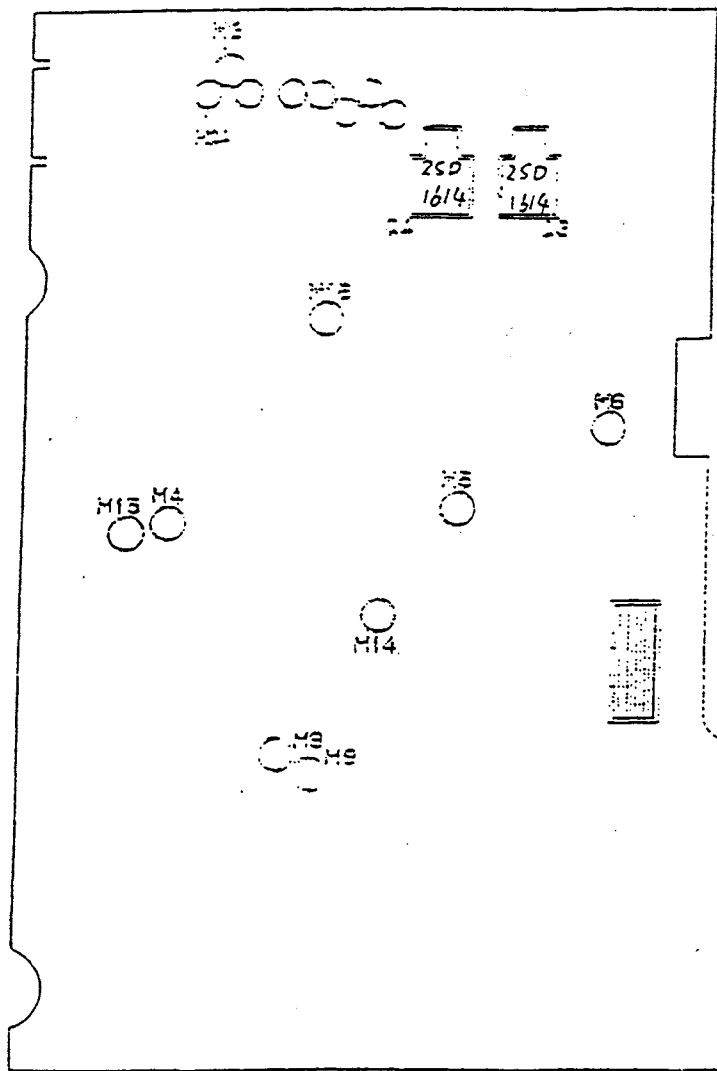

半日面視 半日面

Sold Side

SEGA SEGA ENTERPRISES, LTD.		THIS DRAWING WILL BE NO PART BE COPIED. 此圖不得翻印	
LIMITS UNLESS OTHERWISE SPECIFIED		3PO QUAT PROJ DRAWING	
SCALE 1:1		DIM IN INCH	
MATERIAL		HEAT TREAT.	
FINISH		REMARK	
IC BD 86 MAIN EUROPE		837-7996 (3/4)	
DESCRIPTION NO.		PART NO.	

MACHINE N/A	SUB-ASS'Y N/A
P37-7996B	
ALTERATIONS	REV

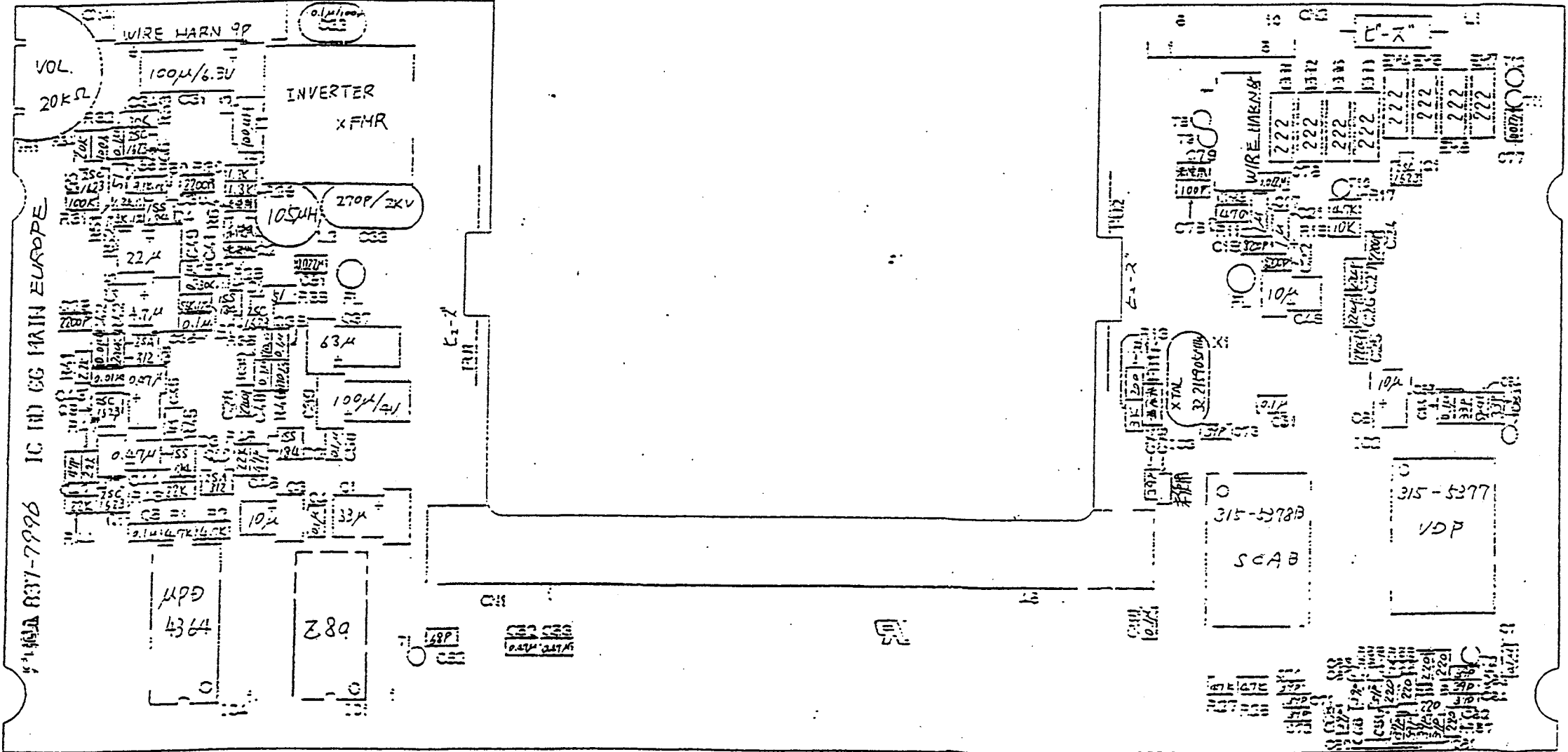

部品面視部面

Comp Side

SEGA SEGA ENTERPRISES, LTD.		THIS DRAWING WILL IN NO WAY BE COPIED, REPRODUCED OR TRANSMITTED IN ANY FORM OR BY ANY MEANS, WITHOUT THE WRITTEN PERMISSION OF SEGA.		許可なく複製・複製・複製	
LIMITS UNLESS OTHERWISE SPECIFIED		3RD QUAT PROJ. DRAWING 第三水準図	図番 図名	単位	出寸
SCALE 1:1		mm	mm	mm	mm
DIM. IN 1/16"		mm	mm	mm	mm
MATERIAL 材料	HEAT TREAT. 熱処理	FINISH 表面処理	REMARK 注記	REV.	REV.
IC BD GA MAIN EUROPE (SCAB)			P37-7996B(34)		
DESCRIPTION 名称			PART NO. 部品番号		

MACHINE	NO.	SUB-ASSY	NO.
		837-79952	
ALTERATIONS			

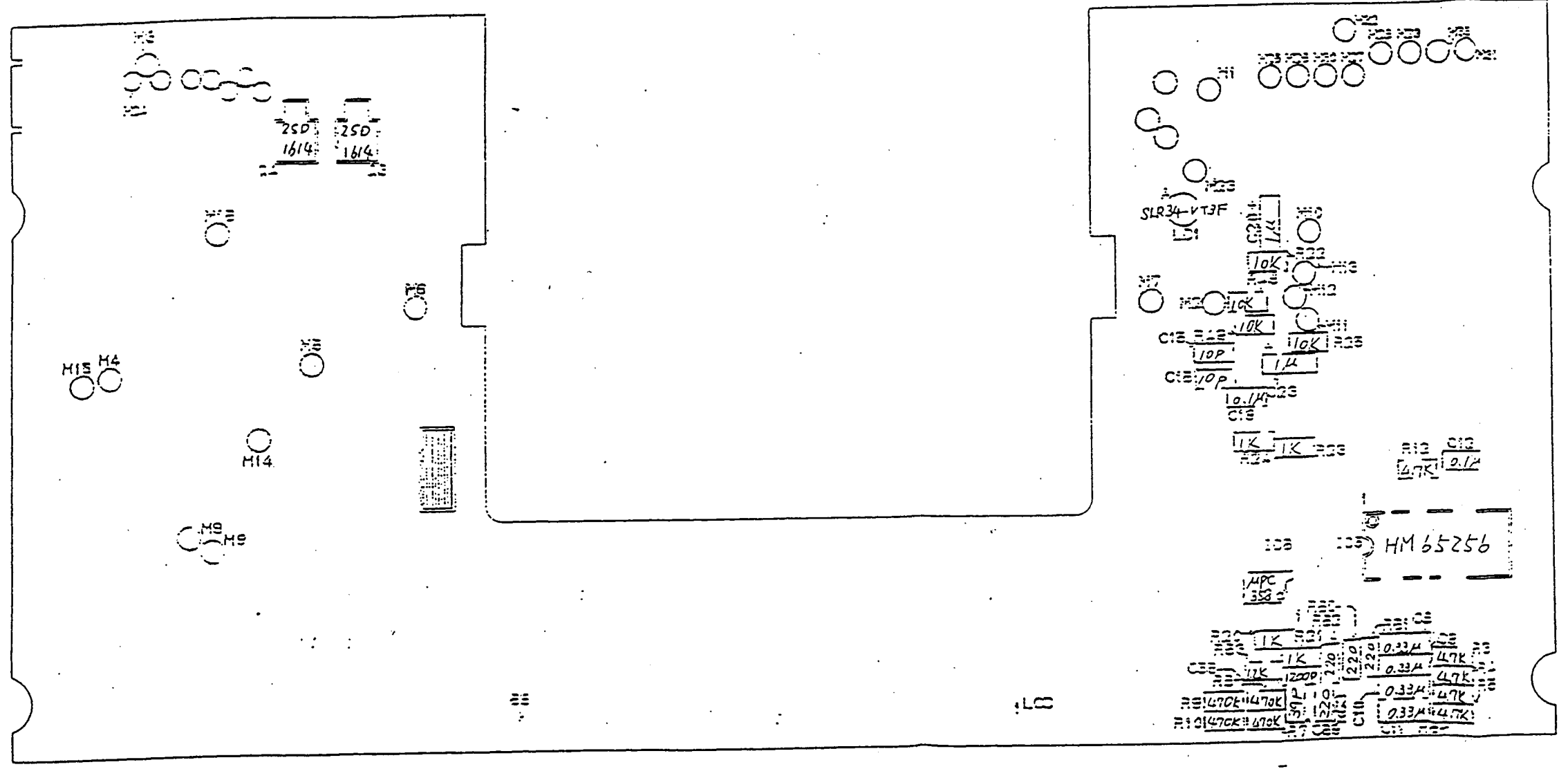

半田面視, 半田面

Sold Side

SEGA SEGA ENTERPRISES, LTD.		THIS DRAWING WILL BE RETURNED TO THE DRAWER ON DEMAND.		許可なく複製 複製禁止	
LIMITS UNLESS OTHERWISE SPECIFIED		3RD QUAT PROJ DRAWING		SCALE: X	
		DIM. IN: mm		DIM. IN: mm	
MATERIAL	HEAT TREAT.	FINISH	REMARK	REV.	
IC BD 65 MAIN EUROPE (SCAB)			837-7996B(3/4)		
DESCRIPTION				PART NO. 148-2289	

837-7996B

PARTS LIST

PART NO. : 837-7997
 DESCRIPTION : IC BD GG DC-DC CONV. EUROPE

LINE	LOCATE	DNO OR	PART NO.	DESCRIPTION
1.00		1	171-6102A	PC BD GG DC-DC CONV. EUROPE
2.00	J1	111	210-5062	CONN DC JACK W/SW LCP4031-0300
3.00	CN1	108	600-5911	WIRE HARN 9P FOR GG 60MM
4.00	SW1	112	510-5028	SLIDE SW HSW1805-010010
5.00	IC1	101	313-5140	IC MB3775PF-G-BND SOP
6.00	Q1	102	482-5125	XSTR 2SA812 M5.7 CHIP
7.00	Q2 (SOLDER)	103	482-5126	XSTR 2SC1623 L5.7 CHIP
8.00	Q3	104	482-5130	XSTR 2SB1301 ZQ OR ZP CHIP
9.00	Q4 (SOLDER)	910	NOT USED	NOT USED
10.00	D1	106	481-5038	DIODE 1SR-35-100A AXIAL
11.00	D2	105	481-5071	DIODE HRF 22 CHIP
12.00	D3	105	481-5071	DIODE HRF 22 CHIP
13.00	D4 (SOLDER)	910	NOT USED	NOT USED
14.00	D5	910	NOT USED	NOT USED
15.00	D6 (SOLDER)	910	NOT USED	NOT USED
16.00	L1	113	180-5071	CHOKE COIL 1.2MH FL7H122J
17.00	L2	114 1	180-5072	CHOKE COIL 68UH TSL1110680K1R
18.00	L2	114 2	180-5083	CHOKE COIL 68UH A90-870-0
19.00	JV	115	271-0017	BEADS INDUCTOR FBA04VA900AB-00
20.00	JG	115	271-0017	BEADS INDUCTOR FBA04VA900AB-00
21.00	R1	122	476-2333-J-10	RES CHIP 33KOHM 1/10W 5%
22.00	R2	121	476-2273-J-10	RES CHIP 27KOHM 1/10W 5%
23.00	R3	117	476-2102-J-10	RES CHIP 1KOHM 1/10W 5%
24.00	R4	119	476-2392-J-10	RES CHIP 3.9KOHM 1/10W 5%
25.00	R5 (SOLDER)	118	476-2222-J-10	RES CHIP 2.2KOHM 1/10W 5%
26.00	R6 (SOLDER)	117	476-2102-J-10	RES CHIP 1KOHM 1/10W 5%
27.00	R7 (SOLDER)	129	476-2114-F-10	RES CHIP 110KOHM 1/10W 1%
28.00	R8 (SOLDER)	126	476-2432-F-10	RES CHIP 4.3KOHM 1/10W 1%
29.00	R9	123	476-2473-J-10	RES CHIP 47KOHM 1/10W 5%
30.00	R10 (SOLDER)	122	476-2333-J-10	RES CHIP 33KOHM 1/10W 5%
31.00	R11 (SOLDER)	120	476-2123-J-10	RES CHIP 12KOHM 1/10W 5%
32.00	R12	130	476-0361-J-04	RES CHIP 360 OHM 1/4W 5%
33.00	R13 (SOLDER)	116	476-2221-J-10	RES CHIP 220 OHM 1/10W 5%
34.00	R14	128	476-2203-F-10	RES CHIP 20KOHM 1/10W 1%
35.00	R15	127	476-2682-F-10	RES CHIP 6.8KOHM 1/10W 1%
36.00	R16 (SOLDER)	910	NOT USED	NOT USED
37.00	R17 (SOLDER)	910	NOT USED	NOT USED
38.00	R18	125	476-2514-F-10	RES CHIP 510KOHM 1/10W 1%
39.00	R19	910	NOT USED	NOT USED
40.00	C1 (SOLDER)	139	153-0088	CAP TANT CP 0.68UF 16V 3216
41.00	C2	133	151-0265	CAP CER CP 0.1UF 25V ZF 2125
42.00	C3	134	151-0269	CAP CER CP 0.1UF 25V K 2125
43.00	C4 (SOLDER)	133	151-0265	CAP CER CP 0.1UF 25V ZF 2125
44.00	C5	135	150-0314	CAP E 22UF 35V N 35SP(X)22
45.00	C6	133	151-0265	CAP CER CP 0.1UF 25V ZF 2125
46.00	C7	131	151-0268	CAP CER CHIP 680PF K B 2125
47.00	C8	134	151-0269	CAP CER CP 0.1UF 25V K 2125
48.00	C9 (SOLDER)	132	NOT USED	NOT USED
49.00	C10	133	151-0265	CAP CER CP 0.1UF 25V ZF 2125
50.00	C11	136	150-0315	CAP E 100UF 25V N 25SP(X)100
51.00	C12 (SOLDER)	133	151-0265	CAP CER CP 0.1UF 25V ZF 2125
52.00	C13	137	150-0316	CAP E 820UF 6.3V N 6.3SP(X)820

PARTS LIST

PART NO. : 837-7997B
 DESCRIPTION : IC BD GG DC-DC CONV. EUROPE B

LINE	LOCATE	DNO	OR	PART NO.	DESCRIPTION
1.00		1		171-6102A	PC BD GG DC-DC CONV. EUROPE
2.00	J1	111		210-5062	CONN DC JACK W/SW LGP4031-03
3.00	CM1	108		600-5911	WIRE HARN 9P FOR GG 60MM
4.00	SW1	112		510-5028	SLIDE SW HSW1805-010010
5.00	IC1	101		313-5140	IC MB3775PF-G-BND SOP
6.00	Q1	102		482-5125	XSTR 2SA812 M5..7 CHIP
7.00	Q2 (SOLDER)	103		482-5126	XSTR 2SC1623 L5..7 CHIP
8.00	Q3	104		482-5130	XSTR 2SB1301 ZQ OR ZP CHIP
9.00	Q4 (SOLDER)	910		NOT USED	NOT USED
10.00	D1	106		481-5038	DIODE 1SR-35-100A AXIAL
11.00	D2	105		481-5071	DIODE HRF 22 CHIP
12.00	D3	105		481-5071	DIODE HRF 22 CHIP
13.00	D4 (SOLDER)	910		NOT USED	NOT USED
14.00	D5	910		NOT USED	NOT USED
15.00	D6 (SOLDER)	910		NOT USED	NOT USED
16.00	L1	113		180-5071	CHOKO COIL 1.2MH FL7H122J
17.00	L2	114	1	180-5072	CHOKO COIL 68UH TSL1110680K11
18.00	L2	114	2	180-5083	CHOKO COIL 68UH A90-870-0
19.00	JV	115		271-0017	BEADS INDUCTOR FBA04VA900AB-0
20.00	JG	115		271-0017	BEADS INDUCTOR FBA04VA900AB-0
21.00	R1	122		476-2333-J-10	RES CHIP 33KOHM 1/10W 5%
22.00	R2	121		476-2273-J-10	RES CHIP 27KOHM 1/10W 5%
23.00	R3	117		476-2102-J-10	RES CHIP 1KOHM 1/10W 5%
24.00	R4	119		476-2392-J-10	RES CHIP 3.9KOHM 1/10W 5%
25.00	R5 (SOLDER)	118		476-2222-J-10	RES CHIP 2.2KOHM 1/10W 5%
26.00	R6 (SOLDER)	117		476-2102-J-10	RES CHIP 1KOHM 1/10W 5%
27.00	R7 (SOLDER)	129		476-2114-F-10	RES CHIP 110KOHM 1/10W 1%
28.00	R8 (SOLDER)	126		476-2432-F-10	RES CHIP 4.3KOHM 1/10W 1%
29.00	R9	123		476-2473-J-10	RES CHIP 47KOHM 1/10W 5%
30.00	R10 (SOLDER)	122		476-2333-J-10	RES CHIP 33KOHM 1/10W 5%
31.00	R11 (SOLDER)	120		476-2123-J-10	RES CHIP 12KOHM 1/10W 5%
32.00	R12	130		476-0361-J-04	RES CHIP 360 OHM 1/4W 5%
33.00	R13 (SOLDER)	116		476-2221-J-10	RES CHIP 220 OHM 1/10W 5%
34.00	R14	128		476-2203-F-10	RES CHIP 20KOHM 1/10W 1%
35.00	R15	127		476-2682-F-10	RES CHIP 6.8KOHM 1/10W 1%
36.00	R16 (SOLDER)	910		NOT USED	NOT USED
37.00	R17 (SOLDER)	910		NOT USED	NOT USED
38.00	R18	125		476-2514-F-10	RES CHIP 510KOHM 1/10W 1%
39.00	R19	910		NOT USED	NOT USED
40.00	C1 (SOLDER)	139		153-0088	CAP TANT CP 0.68UF 16V 3216
41.00	C2	133		151-0265	CAP CER CP 0.1UF 25V ZF 2125
42.00	C3	134		151-0269	CAP CER CP 0.1UF 25V K 2125
43.00	C4 (SOLDER)	133		151-0265	CAP CER CP 0.1UF 25V ZF 2125
44.00	C5	135		150-0314	CAP E 22UF 35V M 35SP(X)22
45.00	C6	133		151-0265	CAP CER CP 0.1UF 25V ZF 2125
46.00	C7	131		151-0268	CAP CER CHIP 680PF K B 2125
47.00	C8	134		151-0269	CAP CER CP 0.1UF 25V K 2125
48.00	C9 (SOLDER)	132		NOT USED	NOT USED
49.00	C10	133		151-0265	CAP CER CP 0.1UF 25V ZF 2125
50.00	C11	136		150-0315	CAP E 100UF 25V M 25SP(X)100
51.00	C12 (SOLDER)	133		151-0265	CAP CER CP 0.1UF 25V ZF 2125
52.00	C13	137		150-0316	CAP E 820UF 6.3V M 6.3SP(X)820

MACHINE 機名	SUB-ASS'Y 組立番
	837-7995
ALTERATIONS 改訂	

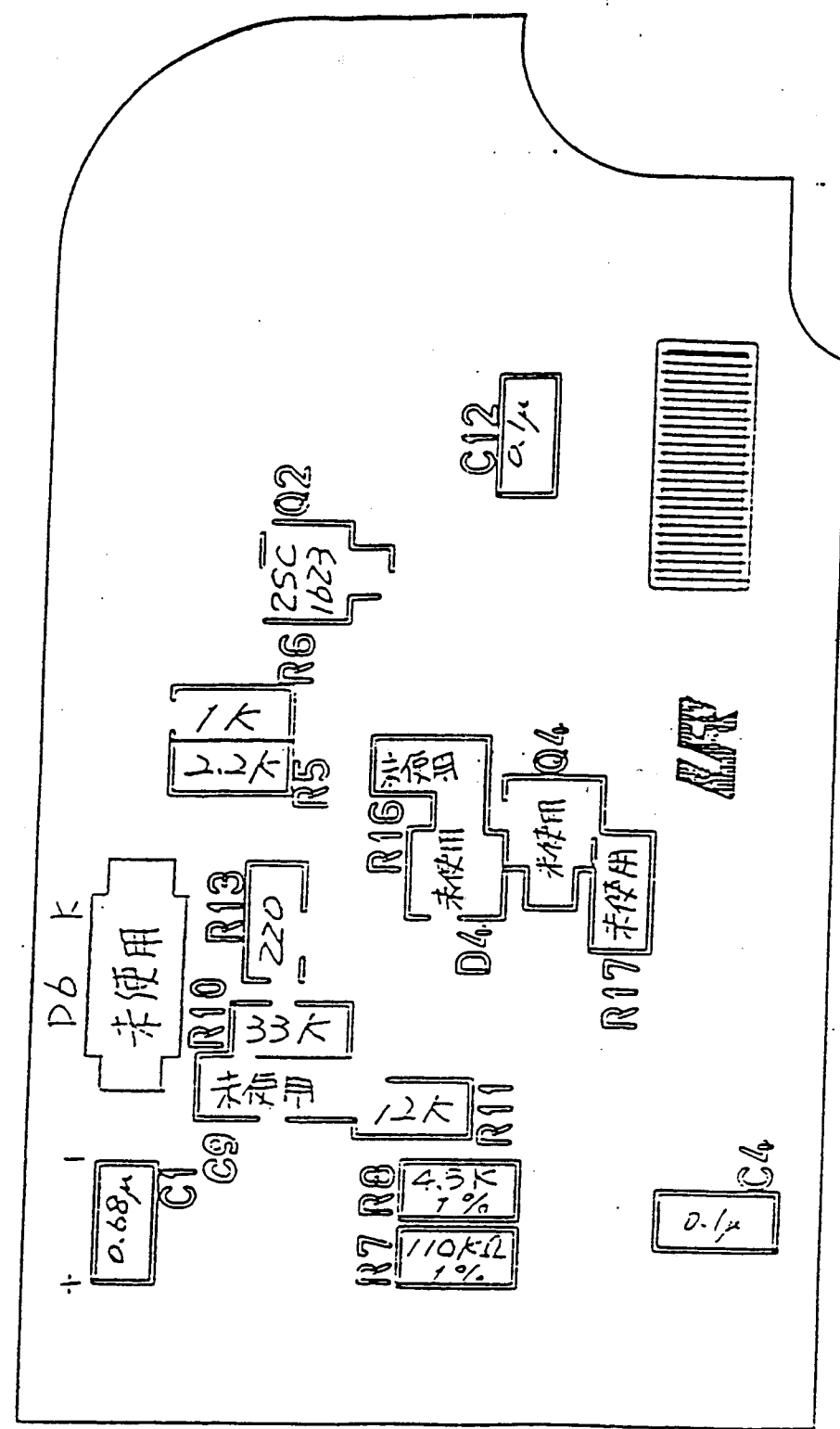

Sold Side 部品面視半田面

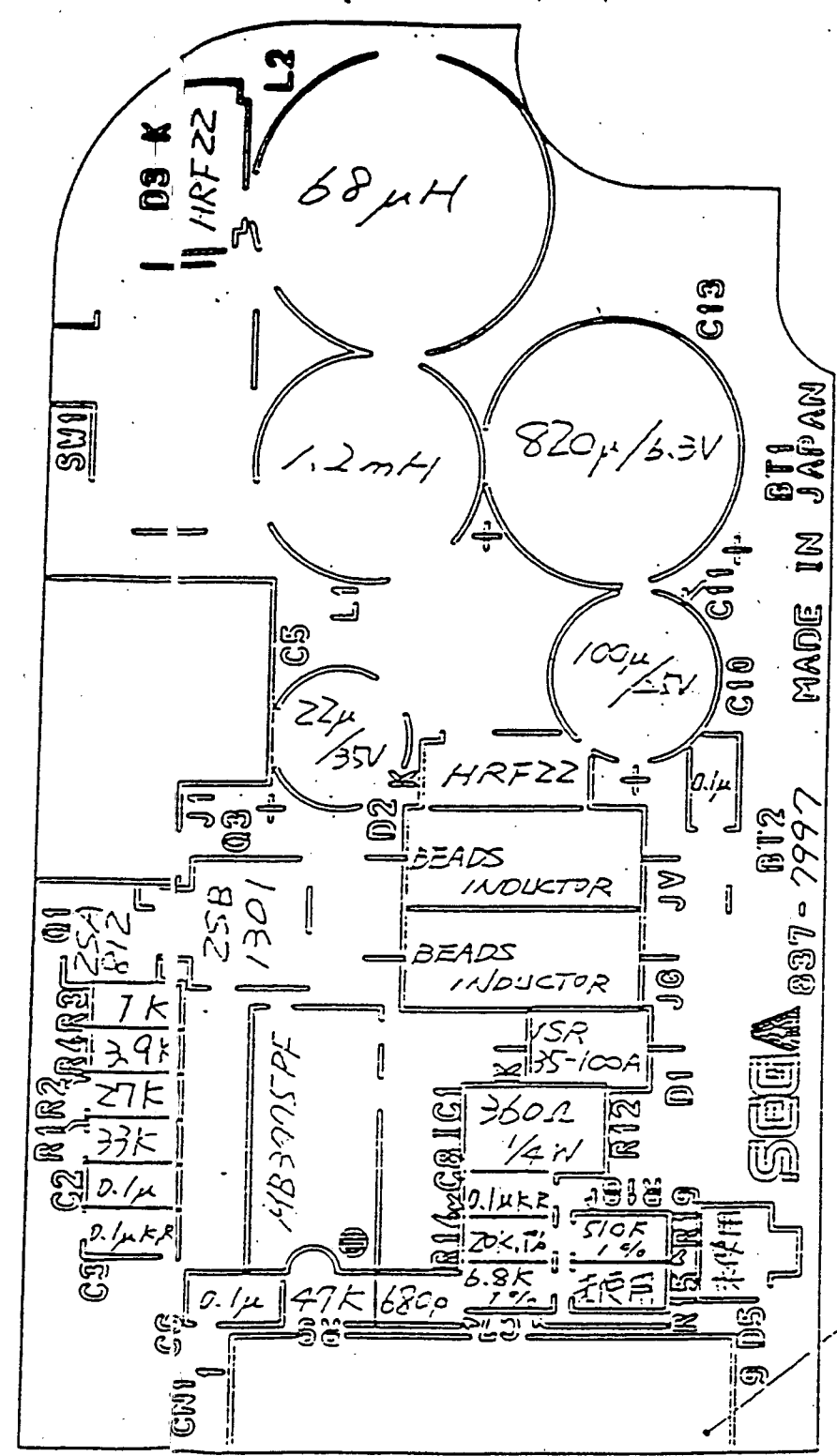

部品面視半田面 Comp Side

108

837-7997 (7/3)

SEGA ENTERPRISES, LTD.		THIS DRAWING WILL IN NO WAY BE COPIED. TO BE RETURNED ON DEMAND.		許可なく複写 複製等禁禁	
LIMITS UNLESS OTHERWISE SPECIFIED 一律寸法		3RD QUAT. PROJ. DRAWING 第三角法	設計・製図	原図	承認
		SCALE 尺寸	X	松本大場	水沢
		DIM. IN 単位	mm	5/8-91	5/9-91
MATERIAL 材料	HEAT TREAT. 熱処理	FINISH 表面処理	REMARK 特殊指示	REV.	
IC BD CA DC-DC CONV. EUROPE			837-7997 (7/3)		
DESCRIPTION 名称			PART NO. 図番・部品番号		

A B C D E F

SMK
LGP 4031-0300

HSW/805-010010

(一) 部品ニ対シテ
ノシテマシテ
1 (A)

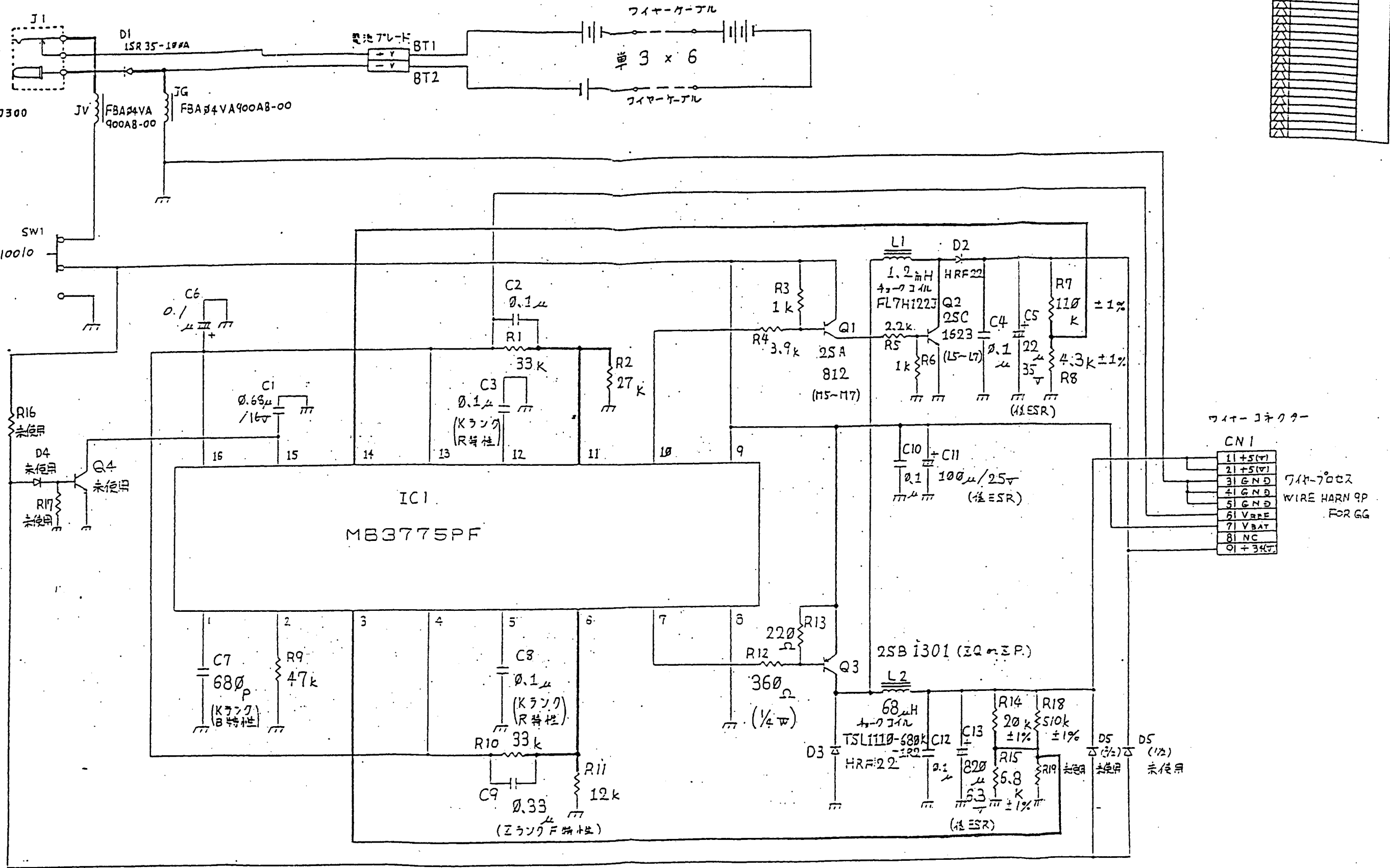

ワイヤコネクタ

1	+5V
2	+5V
3	GND
4	GND
5	GND
6	VREF
7	VBAT
8	NC
9	+3.4V

ワイヤ70ピン
WIRE HARN 9P
FOR GG

IC BD 09 DC-DC CONV. EUROPE 3 337-7997B
IC BD 09 DC-DC CONV. EUROPE 237-7997B

SEGA SEGA ENTERPRISES, LTD.		REV
THIS DRAWING WILL BE NO WAY BE COPIED, 許可なくして TO BE RETURNED ON DEMAND. 返却可能		REV
DC BD 09 DC-DC CONV. EUROPE		REV
DESCRIPTION		171-6102A
DATE		1987. 1. 1
DRAWN		1 / 1

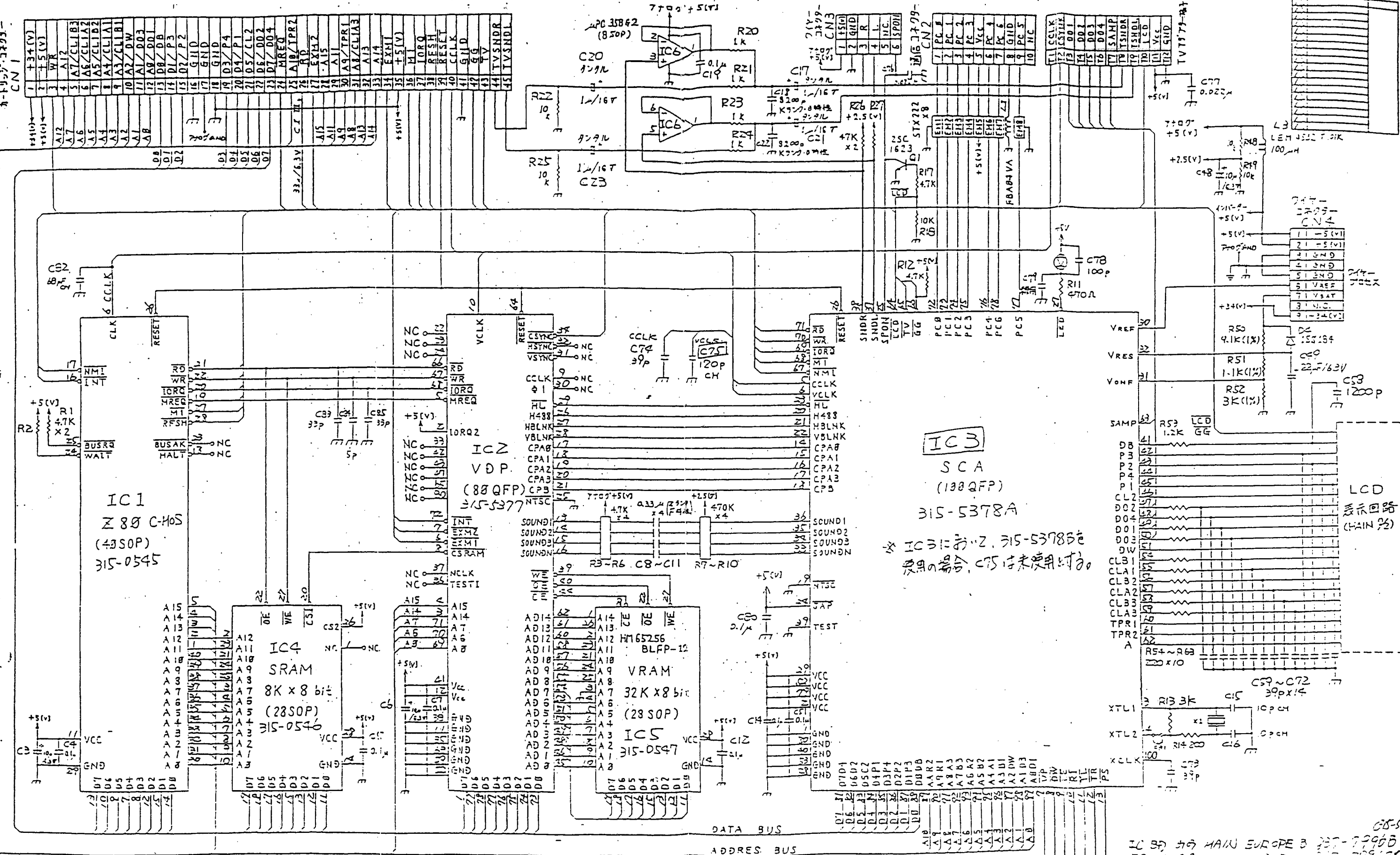

IC3
SCA
(188QFP)
315-5378A

* IC3は、IC2、315-5378Bと
同様の部品、C75は未使用時の。

IC 3D 509 MAIN EUROPE B 357-7990B
IC 3D 509 MAIN EUROPE 357-7990B-509

SEGA SEGA ENTERPRISES, LTD.	REV
PC 3D 509 MAIN EUROPE	REV
DESCRIPTION	

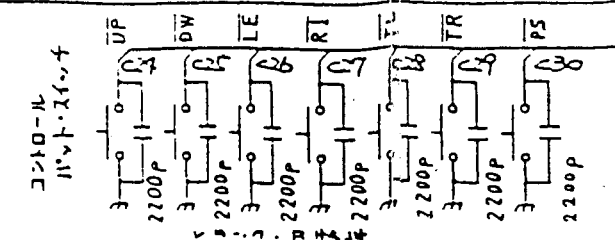

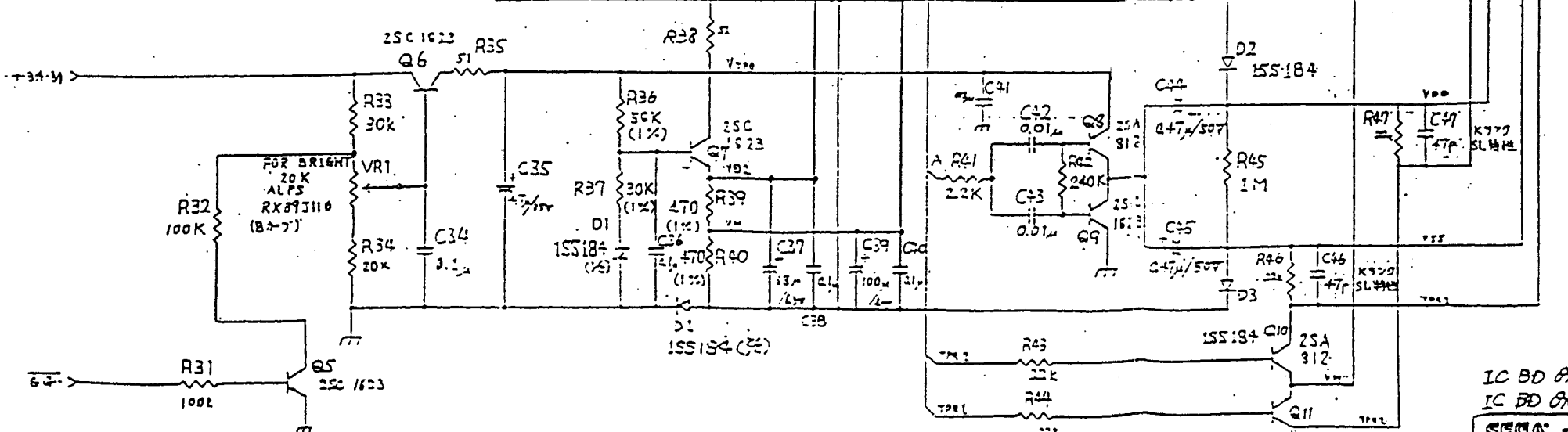
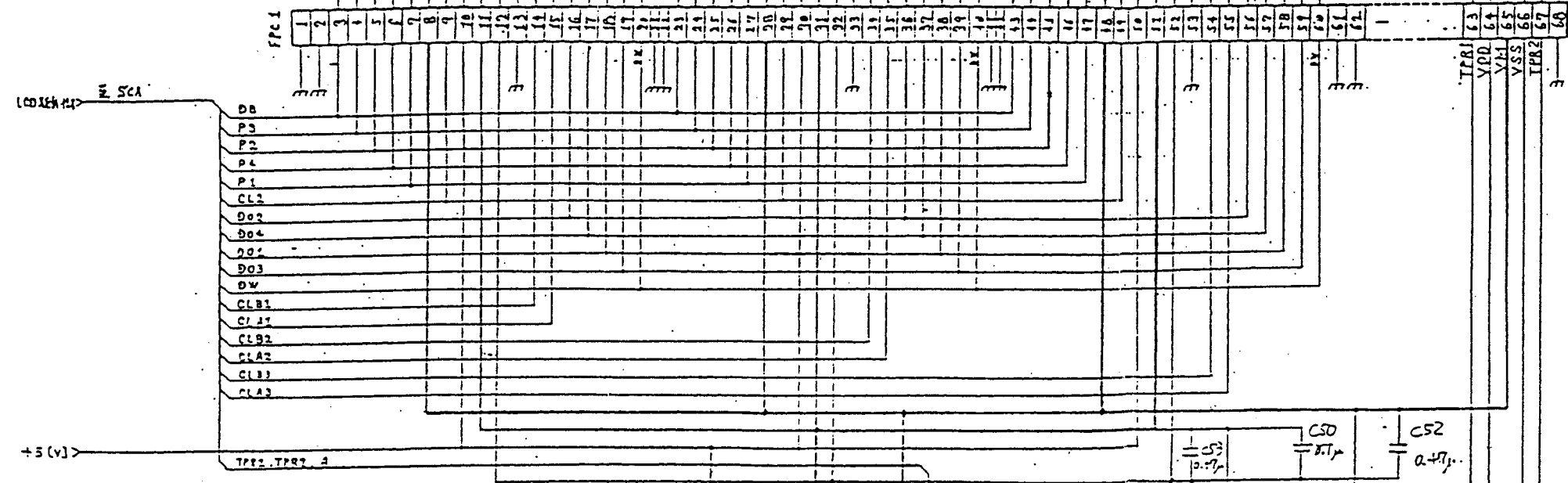
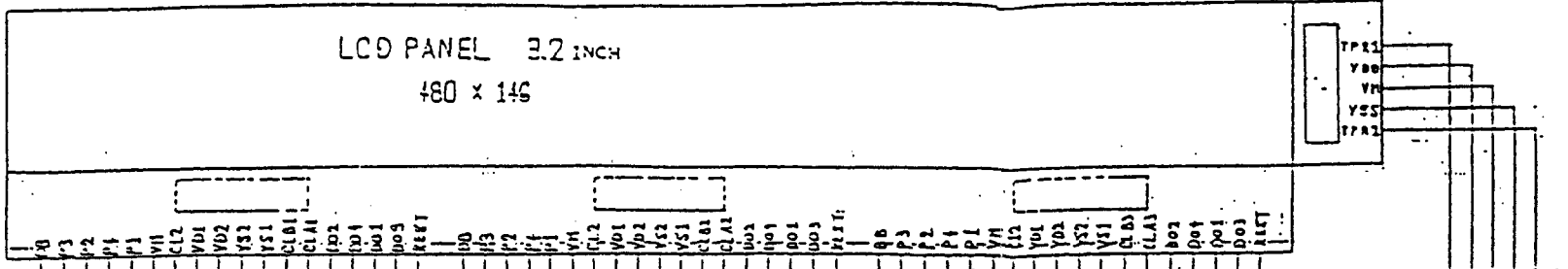
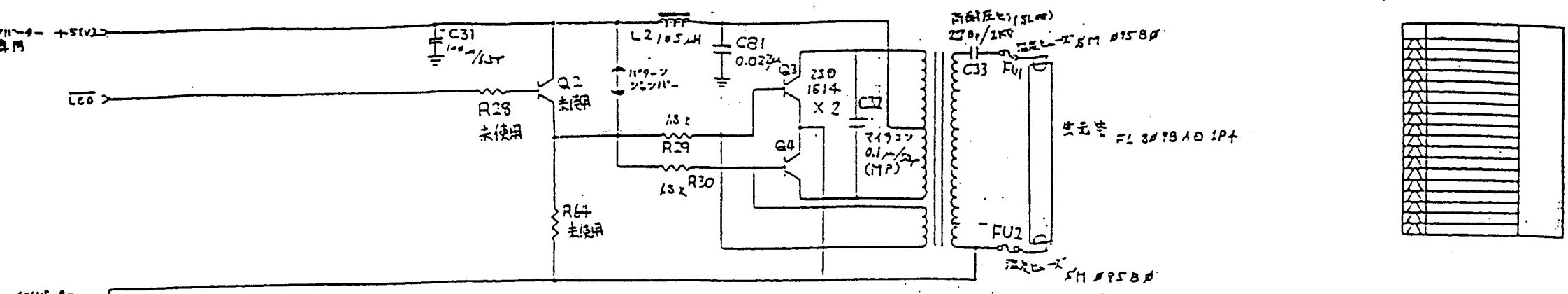

IC BD GA MAIN EUROPE B 237-796B (15-5718A) (A)
 IC BD GA MAIN EUROPE 237-7996 (15-5718A) (A)

SEGA	SEGA ENTERPRISES, LTD.	DATE	
THIS DRAWING SHALL IN NO WAY BE CONSIDERED TO BE RETURNED OR REPRODUCED WITHOUT THE WRITTEN PERMISSION OF SEGA. 此図等は返却されず複製を禁じます。		REV	
PC BD GA MAIN EUROPE		REV	01-2101A
DESCRIPTION		DATE	2. 01. 2