

SEGA™ SERVICE MANUAL

GENESIS II /MEGA DRIVE II (PAL-B/I/G, RGB)



NO.	001
ISSUED	JUNE, 1993

CONTENTS

1. SPECIFICATIONS	3
2. IDENTIFYING PARTS	4
3. DISASSEMBLY	6
4. BLOCK DIAGRAM	7
5. SCHEMATIC DIAGRAMS	8
6. CIRCUIT BOARD DIAGRAMS	12
7. PARTS SPECIFICATIONS	16
8. EXPLODED VIEW & PARTS LIST	28
8-1. EXPLODED VIEW	28
8-2. MECHANICAL PARTS LIST	28
8-3. ELECTRICAL PARTS LIST	29
8-4. ACCESSORIES/PACKAGE LIST	37

Sega Enterprises, Ltd.

Before Using This Service Manual

This service manual includes data for the GENESIS II and MEGA DRIVE II .

- Parts of the circuits are different in the GENESIS II depending on the model of IC11 (RGB encoder used).
Check the model of IC11 on the main circuit board and identify the type, F, S or SM.

Type	Model of IC11	Part No.
F	IC MB3514PF-G-BND-EF	313-5232-A
S	IC CXA1145M-T6 SOP	313-5213-A
SM	IC KA2195D	313-5236-A

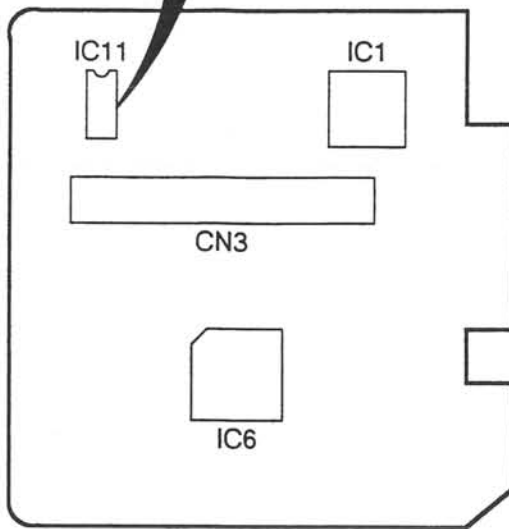

MAIN C.B (Top View)

- Differences in the circuits are shown in the difference tables in the schematic and circuit board diagrams.
- In the parts list, differences are shown in the REMARKS columns.

1. SPECIFICATIONS

RATINGS

Model	GENESIS II	MEGA DRIVE II		
		PAL-I	PAL-B	PAL-G, RGB
Power input	AC 120V, 60Hz	AC220V, 50Hz,	AC 240V, 50Hz	AC 220V, 50Hz
Power consumption	18 W	18 W	18 W	18 W
Usable temperature	Humidity 5-35 °C , 20-80%RH (non-condensing)			
Dimensions	220 (W) × 212 (D) × 59 (H) mm			

SPECIFICATIONS

CPU		68000 (8M) & Z80A (4M)
Memories	RAM	72k bytes
	VRAM	64k bytes
Audio		FM, PSG, PCM
Display capability	VDP	SEGA custom LSI
	Display	Regular color TV
	Colors	512
	Video outputs	VIDEO RGB
Control terminals		2, control pad, etc. can be attached
Reset button		Game restart function
Slots		For cartridge and extension

* Design and specifications are subject to change without notice.

2. IDENTIFYING PARTS

2-1. FRONT & TOP VIEW OF CONSOLE

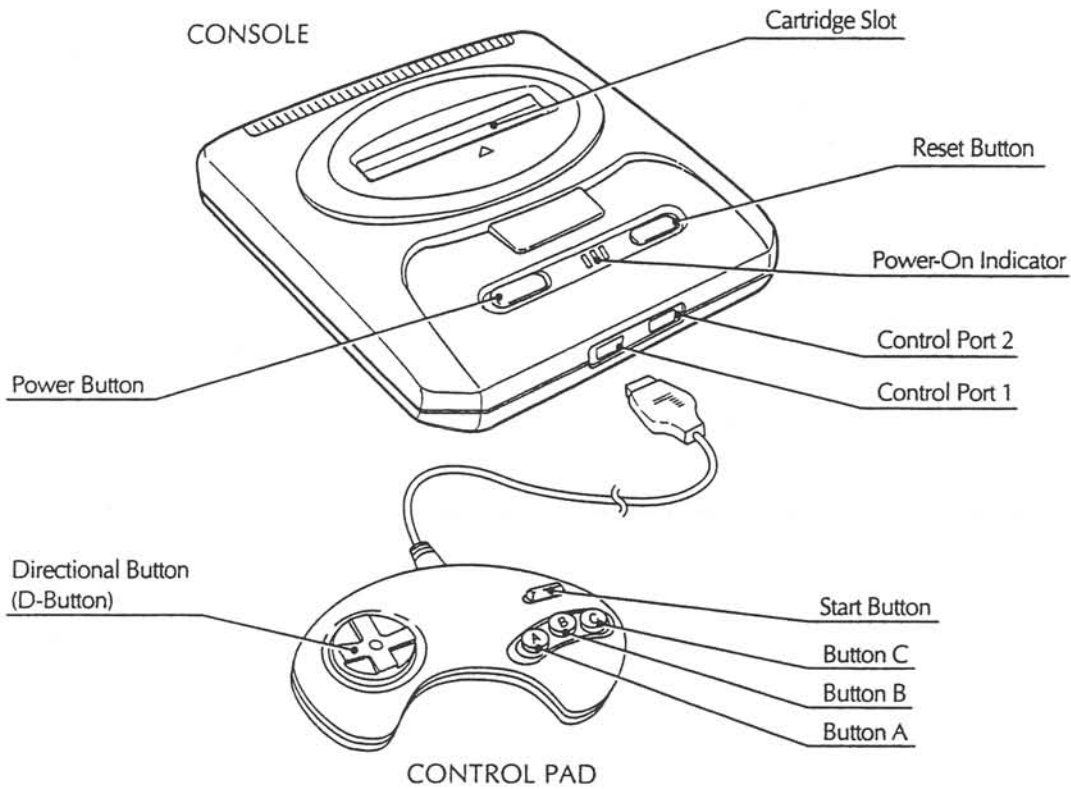

2-2. BACK VIEW OF CONSOLE

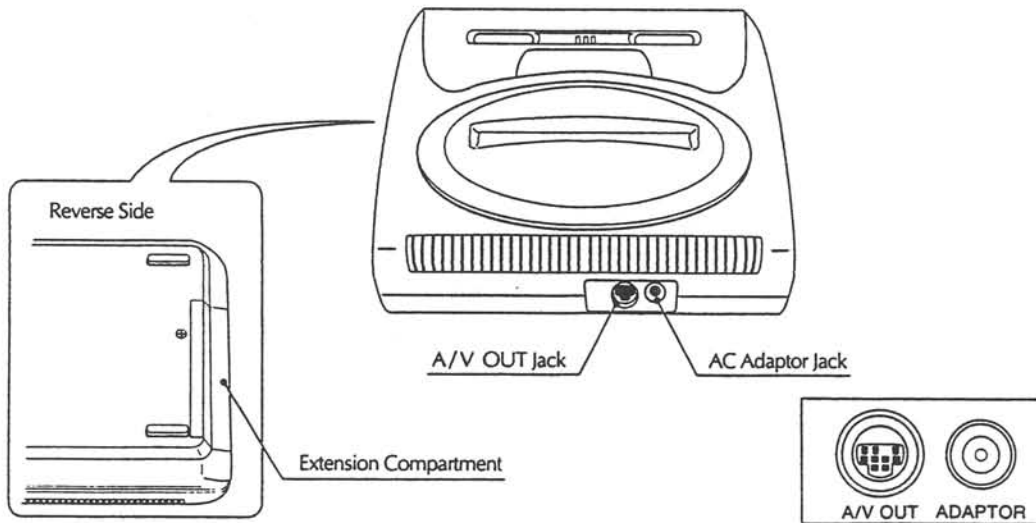

2-3. ACCESSORIES

GENESIS II

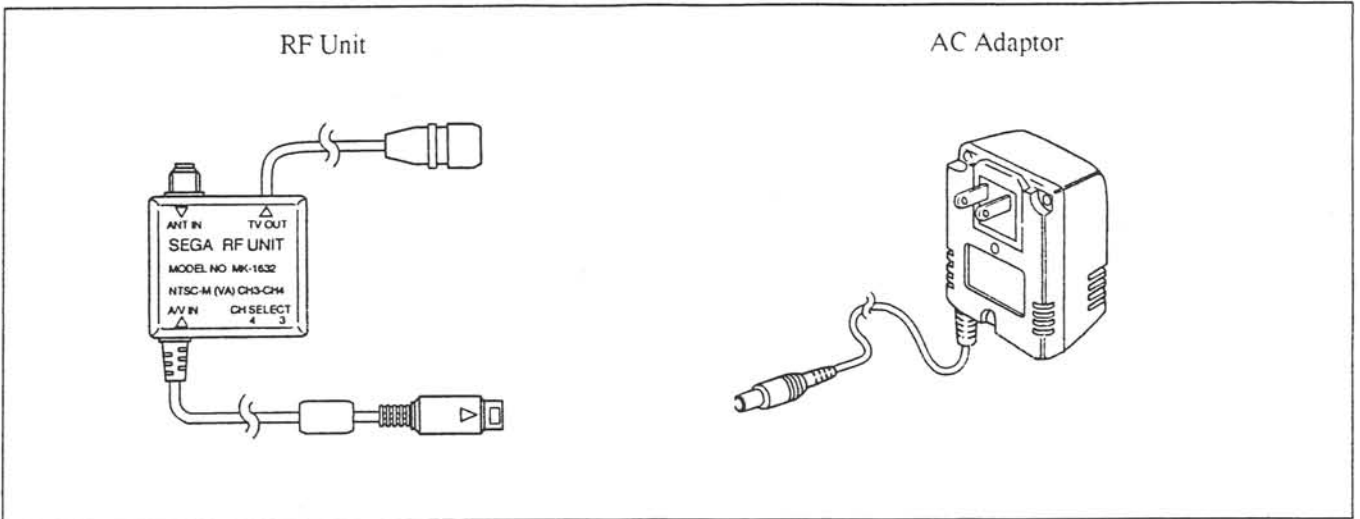

MEGA DRIVE II

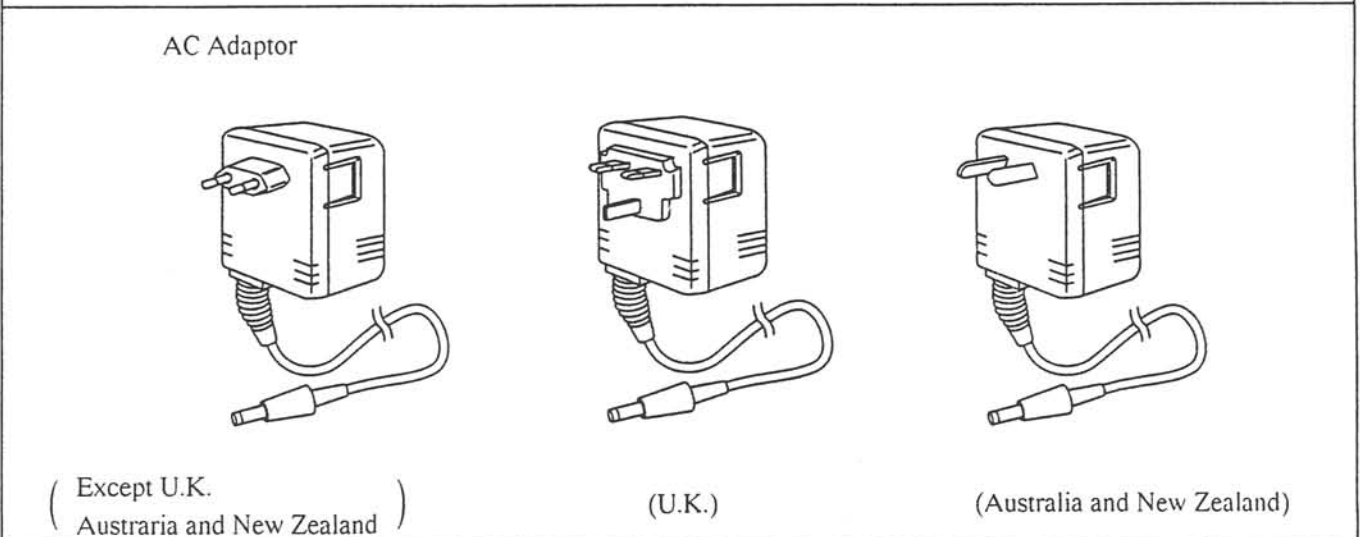
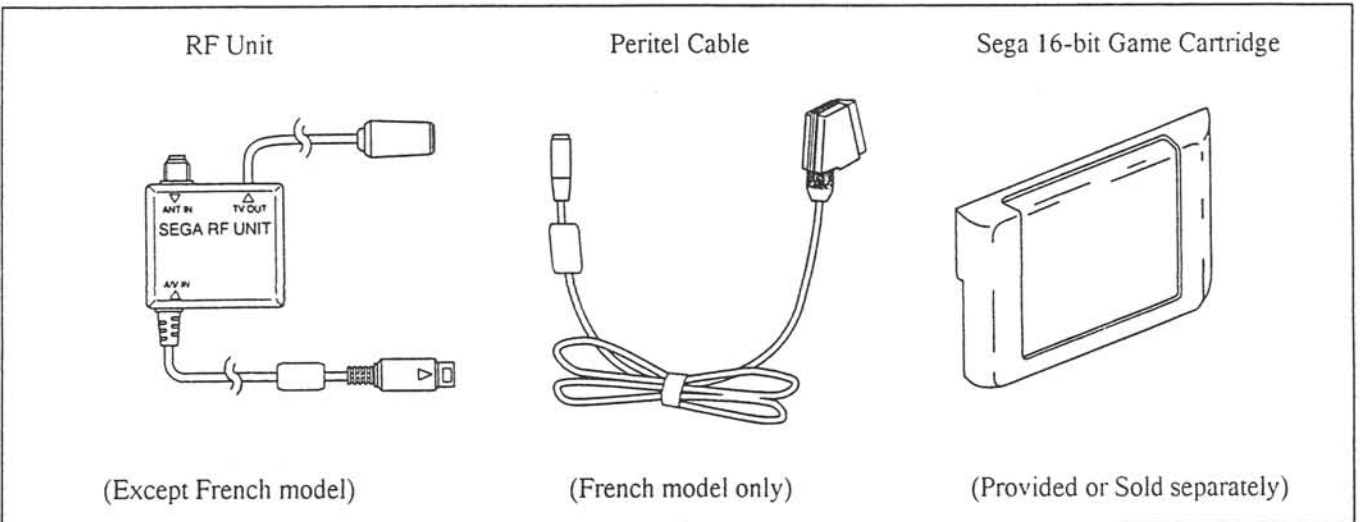

3. DISASSEMBLY

3-1. Dismantling procedure

Removal of bottom screws and top case

- 1) Turn the power button off.
- 2) Turn the unit over. (See Fig. 1)
- 3) Remove four screws (202).
- 4) Remove top case (1).

Main board removal (See Fig. 2)

- 1) Remove nine screws (201).
- 2) Remove the shield plate.
- 3) Remove two screws (203).
- 4) Remove the main board from the bottom case (2).

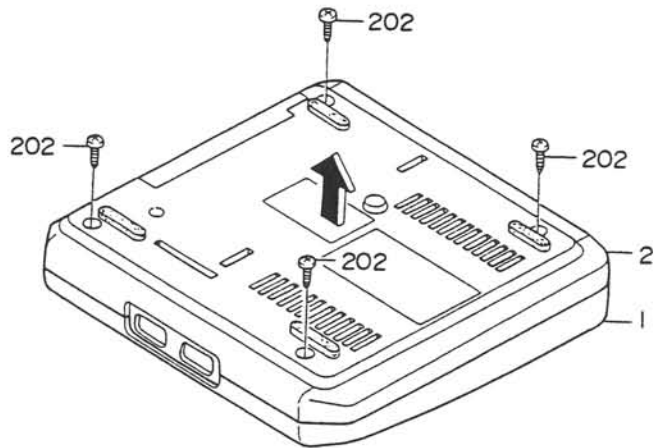

Fig. 1

3-2. Reinstalling procedure

Main board reinstallation

- 1) Attach the 64-pin cover (8).
- 2) Attach the main board to the bottom case.
- 3) Tighten two screws (203).
- 4) Attach the shield plate.
- 5) Tighten nine screws (201).

Top case reinstallation

- 1) Turn off the tactile power switch (TACT SW) on the main board.
- 2) Attach the top case.
- 3) Engage the top case with the bottom case.

Tightening the screws on the bottom case.

- 1) Turn the unit over. (See Fig. 1)
- 2) Tighten four screws (202).

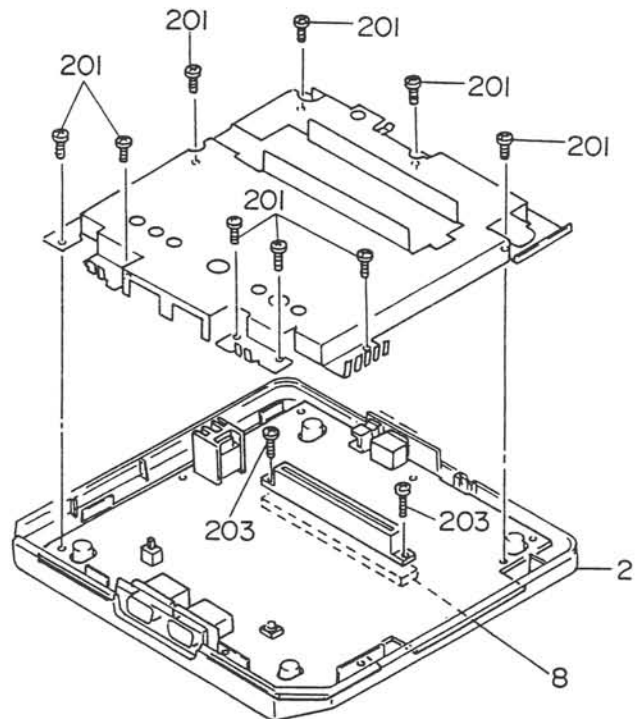
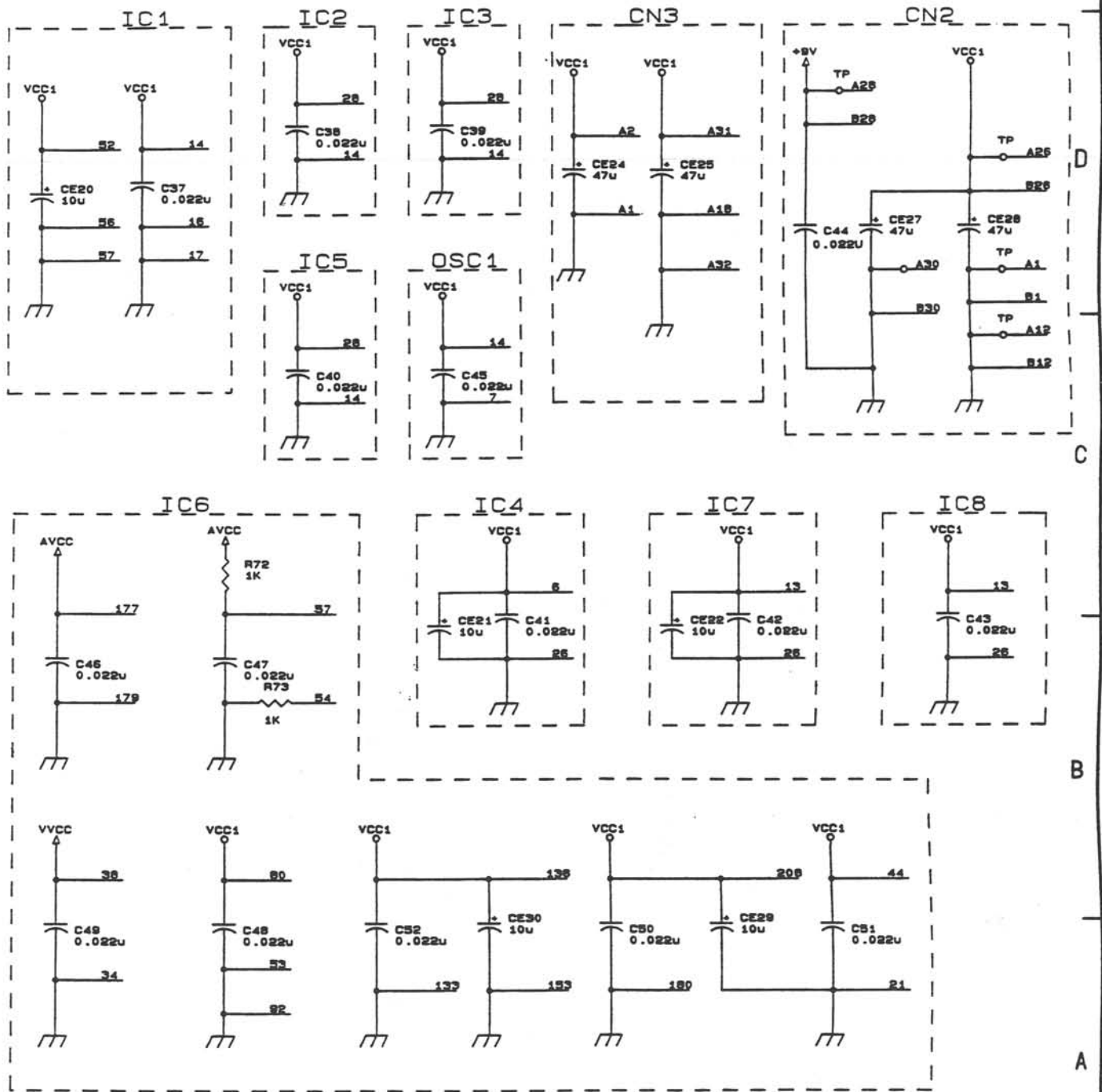

Fig. 2

*** DIFFERENCE TABLE FOR DIAGRAM-1**

CIRCUIT No.	GRID	GENESIS II	MEGA DRIVE II
OSC1	C-5	53.693175MHz	53.203424MHz
C9	E-7	NOT USED	47P
C10	C-5	NOT USED	10P
C11	B-4	NOT USED	33P

5-2. SCHEMATIC DIAGRAM-2



5-3. SCHEMATIC DIAGRAM-3

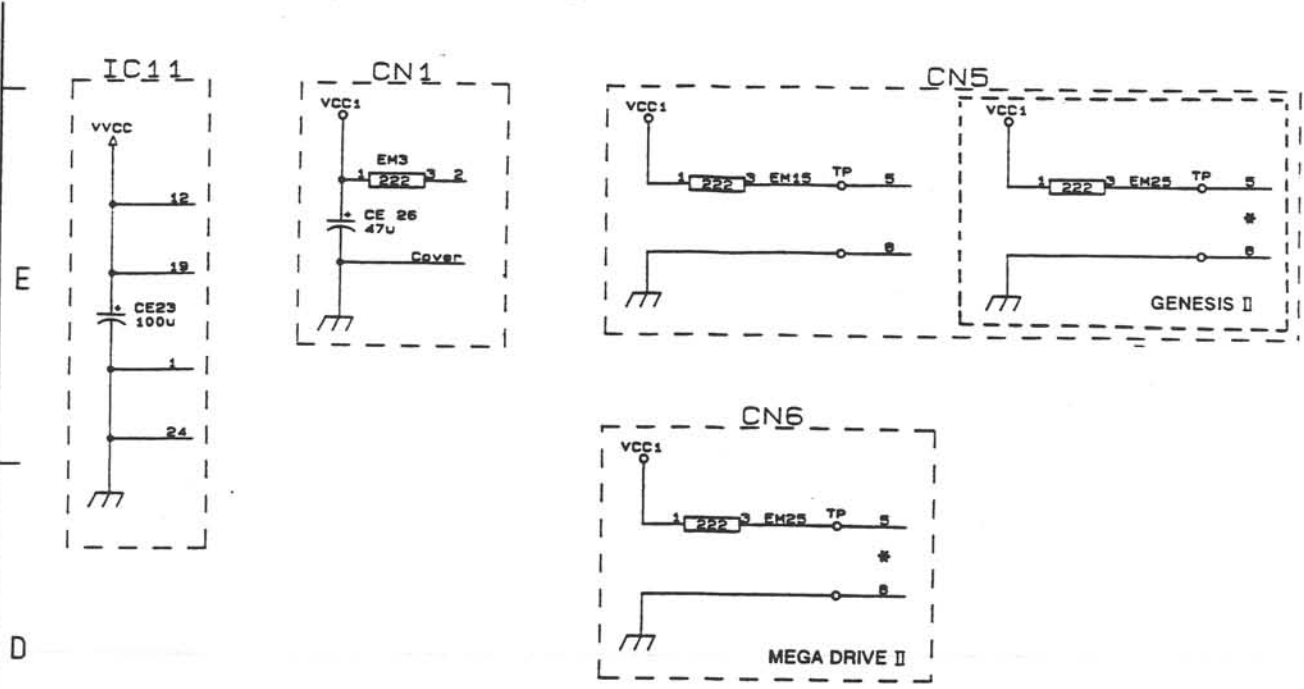

* DIFFERENCE TABLE FOR DIAGRAM-4

CIRCUIT No.	GRID	GENESIS II			MEGA DRIVE II
		TYPE-F	TYPE-S	TYPE-SM	
IC11	E-6	MB3514PF-G-BND-EF	CXA1145-T6 SOP	KA2195D	MB3514PF-G-BND-EF
L2	E-7	100 μ	100 μ	NOT USED	100 μ
L3	D-7	12 μ	12 μ	NOT USED	12 μ
L6	D-7	NOT USED	NOT USED	NOT USED	100 μ
CE14	D-6	220 μ	10 μ	10 μ	220 μ
C28	E-7	18P (CH)	18P (CH)	NOT USED	18P (CH)
C29	D-7	0.01 μ	0.01 μ	NOT USED	0.01 μ
C30	D-7	180P (CH)	180P (CH)	NOT USED	180P (CH)
C32	E-6	15P (CH)	180P (CH)	NOT USED	15P (CH)
C57	D-5	100P (CH)	NOT USED	NOT USED	100P (CH)
C61	D-6	NOT USED	NOT USED	NOT USED	0.1 μ
C62	D-7	NOT USED	NOT USED	NOT USED	12P (CH)
R47	E-6	12K	1.2K	NOT USED	12K
R54	D-6	NOT USED	24K	24K	NOT USED
R55	D-6	10K	1K	NOT USED	10K
R56	D-7	1.2K	1.2K	NOT USED	1.2K
R57	D-7	330	330	NOT USED	1K
R61	E-5	4.7K	10K	10K	4.7K

IC2/3

IC HM65256BLFP-10
Parts No. : 315-0547-10A

IC TC81832AFL-10
Parts No. : 315-0759-10A

IC TC51832FL-10
Parts No. : 315-0677-A

IC LH5P832N-12
Parts No. : 315-0760-12A

IC TC51832AFL-85
Parts No. : 315-0759-85A

Outside View

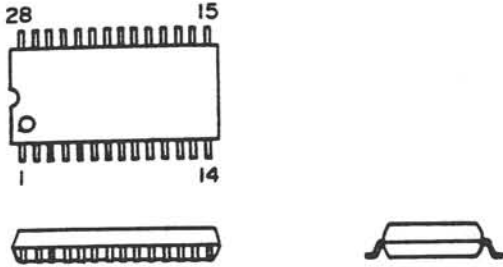

Pin Layout

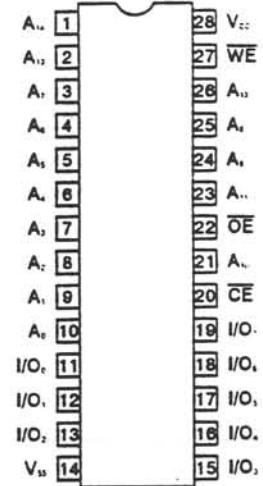

Operation Mode

\overline{CE}	\overline{OE}	\overline{WE}	I/O	MODE
L	L	H	Low Z	Read
L	X	L	High Z	Write
L	H	H	High Z	—
H	L	X	High Z	Refresh
H	H	X	High Z	Standby

Block Diagram

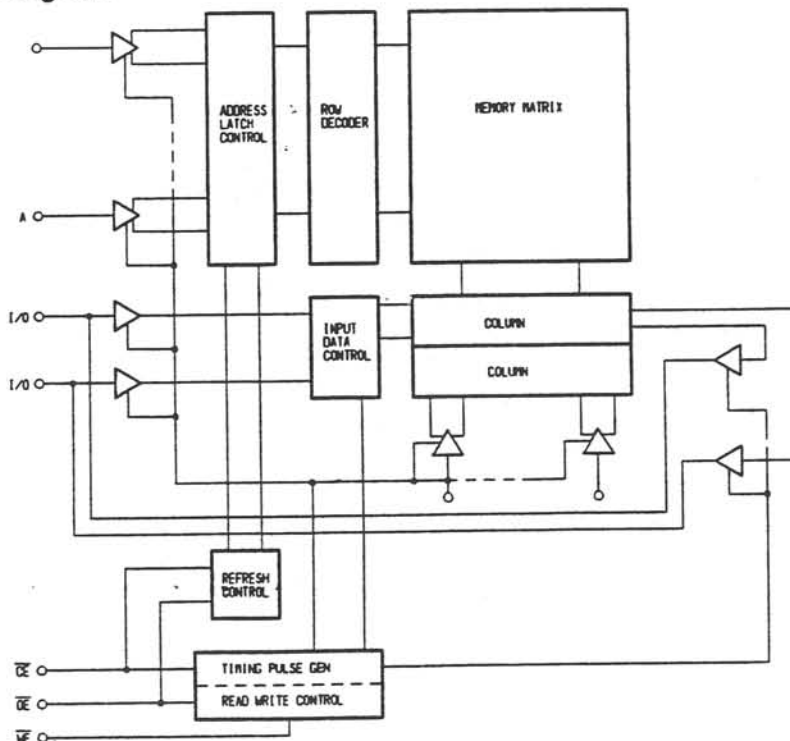

IC4 IC Z84C0006
Parts No. : 315-0738-R

IC UPD9033GB-4-3B4
Parts No. : 315-5676-R

IC TMPZ84C00AU-6
Parts No. : 315-0782-R

■ Outside View

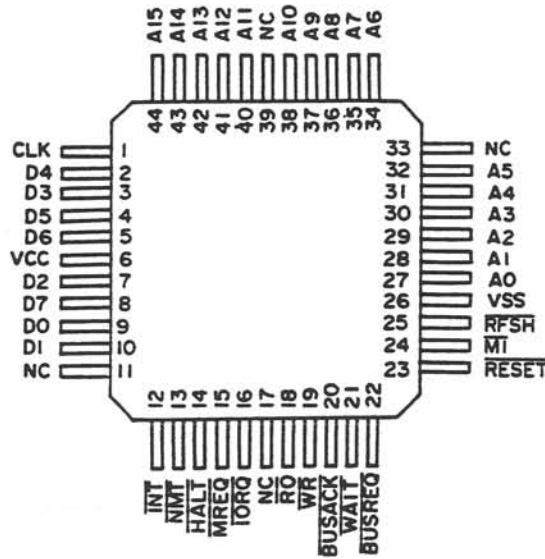

■ Description

Pin No.	Name	I/O	Function
1	CLK	I	Single-phase clock input. When the clock input is set to DC ("1" or "0" level continued), the MPU stops and holds that state.
2-5 7-10	D0-D7	I/O	8-bit bidirectional data bus.
6	Vcc	-	+5V power supply.
11/17	NC (PLCC Only)	-	Not connected internally. Set to open.
12	$\overline{\text{INT}}$	I	Maskable interrupt request signal. Interrupts are given by a peripheral LSI. When the interrupt enable flipflop (IFF) is set to "1" by software, the interrupt is accepted. $\overline{\text{INT}}$ is usually used as the wired OR and a pull-up resistor is added externally.
13	$\overline{\text{NMI}}$	I	Non-maskable interrupt request signal. This interrupt request has priority over the maskable interrupt and does not depend on the state of the interrupt enable flipflop (IFF).
14	$\overline{\text{HALT}}$	I	Halt signal. "0" is output when the MPU executes a HALT command and is set to the HALT state.
15	$\overline{\text{MREQ}}$	I	Memory request signal. "0" is output when there is an effective address for memory access on the address bus. MRFQ also goes "0" together with the $\overline{\text{RFSH}}$ signal during memory refresh.

Pin No.	Name	I/O	Function
16	$\overline{\text{IORQ}}$	O	Input/output request signal. "0" is output when the address for input/output is on the low-order 8 bits (A0-A7) of the address bus when an input or output is given. The $\overline{\text{IORQ}}$ signal is also output together with the $\overline{\text{MI}}$ signal when an interrupt is acknowledged to inform the peripheral LSI that the interrupt response vector can be superimposed on the data bus.
18	$\overline{\text{RD}}$	O	READ signal. "0" is output while the MPU can accept the data from a peripheral LSI. The data in the designated LSI or memory is gated by this signal and can be superimposed on the MPU data bus.
19	$\overline{\text{WR}}$	O	WRITE signal. This is output when the data to be stored in the memory or peripheral LSI is superimposed on the MPU data bus.
20	$\overline{\text{BUSACK}}$	O	Bus acknowledge signal. When the $\overline{\text{BUSREQ}}$ signal is input, the $\overline{\text{BUSACK}}$ signal informs the peripheral LSIs that the address bus and data bus of the MPU and the $\overline{\text{MREQ}}$, $\overline{\text{IORQ}}$, $\overline{\text{RD}}$ and $\overline{\text{WR}}$ signals have been set to high impedance.
21	$\overline{\text{WAIT}}$	I	WAIT signal. The $\overline{\text{WAIT}}$ signal informs the MPU that the designated memory or peripheral LSI is not ready for data transfer. The MPU continues in the wait state as long as the $\overline{\text{WAIT}}$ signal is "0".
22	$\overline{\text{BUSREQ}}$	I	Bus request signal. The $\overline{\text{BUSREQ}}$ signal requests to set the address bus and data bus of the MPU and the $\overline{\text{MREQ}}$, $\overline{\text{IORQ}}$, $\overline{\text{RD}}$ and $\overline{\text{WR}}$ signals to high impedance. $\overline{\text{BUSREQ}}$ is usually used as the wired OR and a pull-up resistor is connected externally.
23	$\overline{\text{RESET}}$	I	Reset signal. The $\overline{\text{RESET}}$ signal initializes the MPU and should be active ("0") for at least 3 clock-signal periods.
24	$\overline{\text{MI}}$	O	Signal that indicates machine cycle 1. "0" is output together with the $\overline{\text{MREQ}}$ in the command operation code fetch cycle. When 2-byte operation codes are executed, MI is output each time the operation code is fetched. MI is output with the $\overline{\text{IORQ}}$ signal in the maskable interrupt acknowledge cycle.
25	$\overline{\text{RFSH}}$	O	Refresh signal. "0" is output when the address that refreshes the dynamic memory is on the low-order 7 bits of the address bus. The $\overline{\text{MREQ}}$ signal also goes active ("0") in this state.
26	Vss	—	0V power supply
27-32 34-38 40-44	A0~A15	O	16-bit address bus. Address the memory and input/output ports. The address for refreshing is output during refreshing.

IC5 IC UPD4364G-15L
Parts No. : 315-0546-A

IC LC3564PM-10L
Parts No. : 315-0753-10A

IC KM6264BLG-10L
Parts No. : 315-0755-A

IC CXK5864CM-70LL-T6
Parts No. : 315-0773-A

IC MB8464A-80
Parts No. : 315-0651-A

IC LC3564PM-12L
Parts No. : 315-0753-12A

IC LC3664BML-85H
Parts No. : 315-0766-85

IC MB8464A-10LL
Parts No. : 315-0635-A

IC KM6264BLG-10
Parts No. : 315-0754-A

IC LC3664BML-10H
Parts No. : 315-0766-10

■ Outside View

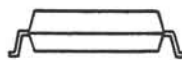

■ Pin Layout

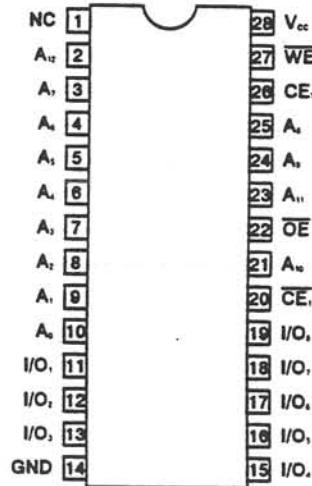

A₁-A₁₁ : ADDRESS INPUT
 OE : OUTPUT ENABLE INPUT
 I/O₁-I/O₁₀ : DATA IN/OUTPUT
 V_{cc} : +5V POWER SUPPLY
 CE₁, CE₂ : CHIP ENABLE 1, 2 INPUT
 GND : GROUND
 WE : WRITE ENABLE INPUT
 NC : NO CONNECTION

■ Operation Mode

CE ₁	CE ₂	OE	WE	MODE	OUTPUT STATE	POWER SUPPLY CURRENT
H	×	×	×	Non-Select (Power Down)	High Impedance	I _{SB}
×	L	×	×			
L	H	H	H	Output Disable		I _{CCA}
L	H	L	H	Read	D _{OUT}	
L	H	×	L	Write	D _{IN}	

■ Block Diagram

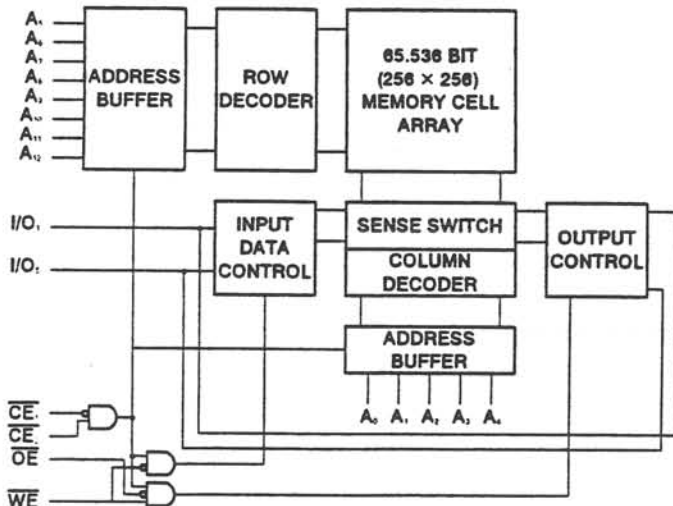

IC6 IC CUSTOM FC1004 REV.
Parts No. : 315-5660-R

■ Outside View

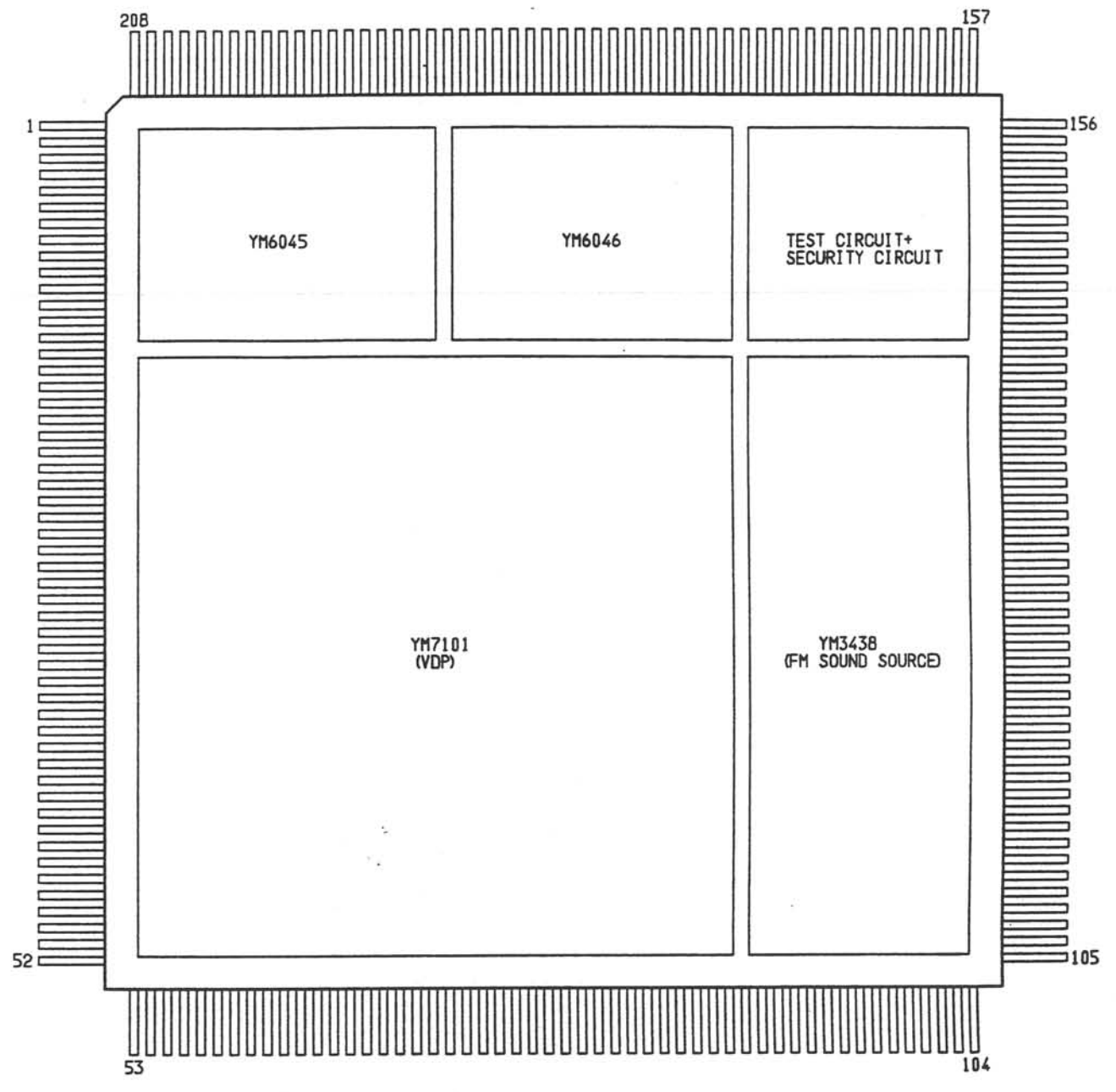

■ Description

Pin No.	Name	I/O	Function
1	SD0	I	Dual Port RAM Interface Signals.
2	SD1		
3	SD2		
4	SD3		
5	SD4		
6	SD5		
7	SD6		
8	SD7		
9	- SE1	O	Dual Port RAM Interface Signals.
10	- SE0		
11	- SC		
12	- RAS1		
13	- CAS1		
14	- WE1		
15	- WE0		
16	- OE1		
17	RD0	I/O	Dual Port RAM Interface Signals.
18	RD1		
19	RD2		
20	RD3		
21	VSS	-	GND
22	RD4	I/O	Dual Port RAM Interface Signals.
23	RD5		
24	RD6		
25	RD7		
26	AD0		
27	AD1		
28	AD2		
29	AD3		
30	AD4		
31	AD5		
32	AD6		
33	AD7		
34	VIDEO AVSS	-	VIDEO+PSG
35	R (ANLONG)	O	
36	G (ANLONG)		
37	B (ANLONG)		
38	VIDEO AVDD	-	
39	- YS	O	
40	SPA/B	I/O	

Pin No.	Name	I/O	Function
41	- VSYNC	O	
42	- CSYNC	I/O	VIDEO+PSG
43	- HSYNC	I/O	
44	VDD	-	Power Supply.
45	- M3	I	
46	- NTSC		
47	- VPA	O	68000 Interface Signals.
48	- HALT		
49	- RESET		
50	FC0	I	
51	FC1		
52	- MREQ	I/O	Z80 Interface Signals.
53	VSS	-	GND
54	AUSS	-	FM
55	MOR (ANLONG)	O	
56	MOL (ANLONG)	-	
57	SOUND AVDD	-	
58	- SOUND	I/O	Use This Pin Set To Open Certainly.
59	- ZRES	I/O	Z80 Interface Signals.
60	- ZBAK	I	
61	- NMI	O	
62	- ZBR	I/O	
63	- WAIT		
64	- EOE	O	P-SRAM Interface.
65	- NOE	O	SRAM Interface.
66	- ZRAM	O	
67	- REF	O	
68	- CAS2		
69	- RAS2		
70	- ASEL		
71	- ROM		
72	- FDC		
73	- FDWR		
74	- CEO		
75	- TIME	I	
76	- CART		
77	IA14	O	
78	- WRES	I	
79	- DISK	I/O	

Pin No.	Name	I/O	Function
80	VDD	-	Power Supply.
81	TEST0	I/O	Test Signal. (Set To "0" Certainly.)
82	TEST1	I	Test Signals. (These Pins Set To All Open.)
83	TEST2		
84	TEST3		
85	PC0		
86	PC1	I/O	Joy Pad Interface.
87	PC2		
88	PC3		
89	PC4		
90	PC5		
91	PC6		
92	VSS	-	GND
93	PB0	I/O	Joy Pad Interface.
94	PB1		
95	PB2		
96	PB3		
97	PB4		
98	PB5		
99	PB6		
100	PA0		
101	PA1		
102	PA2		
103	PA3		
104	PA4		
105	PA5		
106	PA6		
107	- JAP	I/O	
108	- FRES		
109	ZV	I/O	Use This Pin Set To Open Certainly.
110	VZ		
111	IO		
112	ZA0	I/O	Z80 Address Bus.
113	ZA1		
114	ZA2		
115	ZA3		
116	ZA4		
117	ZA5		
118	ZA6		
119	ZA7		

Pin No.	Name	I/O	Function
120	ZA8	I/O	Z80 Address Bus.
121	ZA9		
122	ZA10		
123	ZA11		
124	ZA12		
125	ZA13		
126	ZA14		
127	ZA15		
128	- SRES	I	
129	SEL1		
130	CLK	I/O	68000 Interface Signals.
131	SBCR	O	VIDEO+PSG
132	ZCLK	I/O	Z80 Interface Signals.
133	VSS	-	GND
134	MCLK	I	
135	EDCLK	I/O	
136	VDD	-	Power Supply.
137	VD0	I/O	68000 Data Bus.
138	VD1		
139	VD2		
140	VD3		
141	VD4		
142	VD5		
143	VD6		
144	VD7		
145	VD8		
146	VD9		
147	VD10		
148	VD11		
149	VD12		
150	VD13		
151	VD14		
152	VD15		
153	VSS	-	GND
154	VA1	I/O	68000 Address Bus.
155	VA2		
156	VA3		
157	VA4		
158	VA5		
159	VA6		

Pin No.	Name	I/O	Function
160	VA7	I/O	68000 Address Bus.
161	VA8		
162	VA9		
163	VA10		
164	VA11		
165	VA12		
166	VA13		
167	VA14		
168	VA15		
169	VA16		
170	VA17		
171	VA18		
172	VA19		
173	VA20		
174	VA21		
175	VA22		
176	VA23		
177	SOUND AVDD	-	VIDEO+PSG
178	PSG (ANLONG)	O	
179	SOUND AVSS	-	
180	VSS	-	GND
181	- INT	O	Z80 Interface Signals.
182	- BR	O	68000 Interface Signals.
183	- BGACK	I/O	
184	- BG	I	
185	- IPL1	O	
186	- IPL2	I	
187	- IORQ	O	
188	- ZRD	I	Z80 Interface Signals.
189	- ZWR	I/O	
190	- M1	I	
191	- AS	I/O	68000 Interface Signals.
192	- UDS		
193	- LDS		
194	R/W		
195	- DTAK		
196	- UWR	O	P-SRAM Interface.
197	- LWR	I/O	
198	- CASO	I/O	
199	- RASO	O	P-SRAM Interface.

Pin No.	Name	I/O	Function
200	ZD0	I/O	Z80 Data Bus.
201	ZD1		
202	ZD2		
203	ZD3		
204	ZD4		
205	ZD5		
206	ZD6		
207	ZD7		
208	VDD	-	Power Supply.

IC7/8

IC M5M4C264L-12

Parts No. : 315-0515

IC MB81461-12

Parts No. : 315-0423

IC V53C261Z10

Parts No. : 315-0616

IC KM424C64Z-12

Parts No. : 315-5543

IC M5M4C264L-15

Parts No. : 315-0515-15

IC HM53461ZP-12

Parts No. : 315-0481

IC KM424C64Z-10

Parts No. : 315-0622

IC UPD41264V-12

Parts No. : 315-0453

IC TMS4461-12

Parts No. : 315-0525

IC MSM51C262-10

Parts No. : 315-0623

Outside View

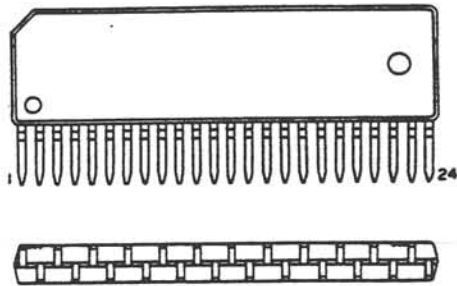

Pin Layout

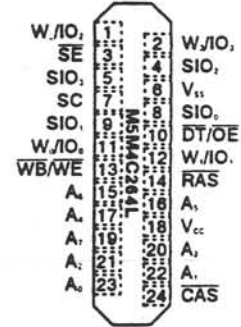

Block Diagram

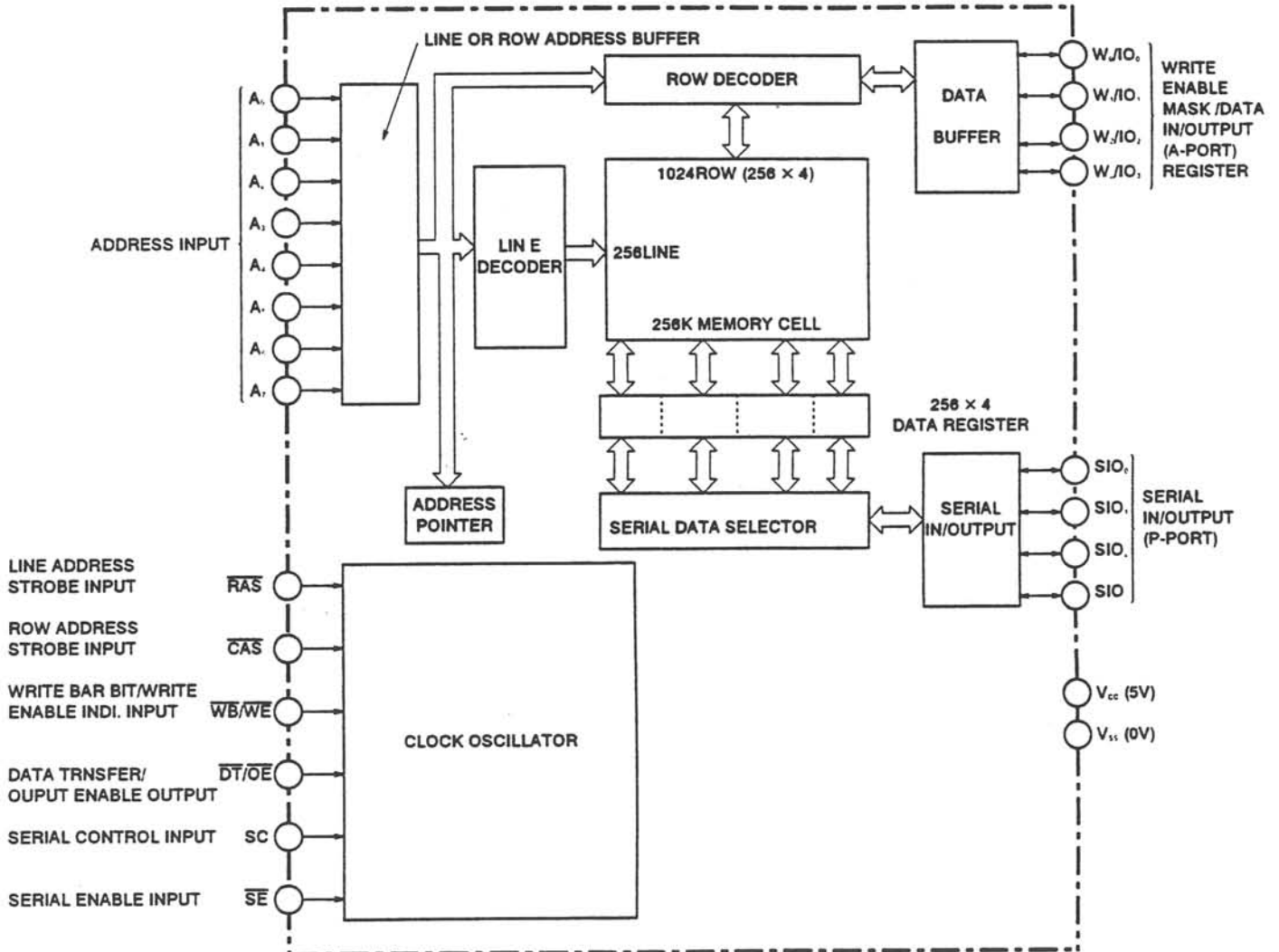

IC9/10

IC BA10324AF-T1
Parts No. : 313-5221-A

IC LM324

Parts No. : 313-5063-A

■ Outside View

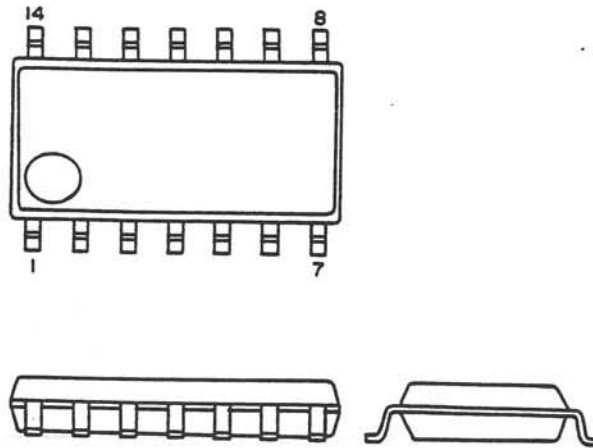

■ Pin Layout

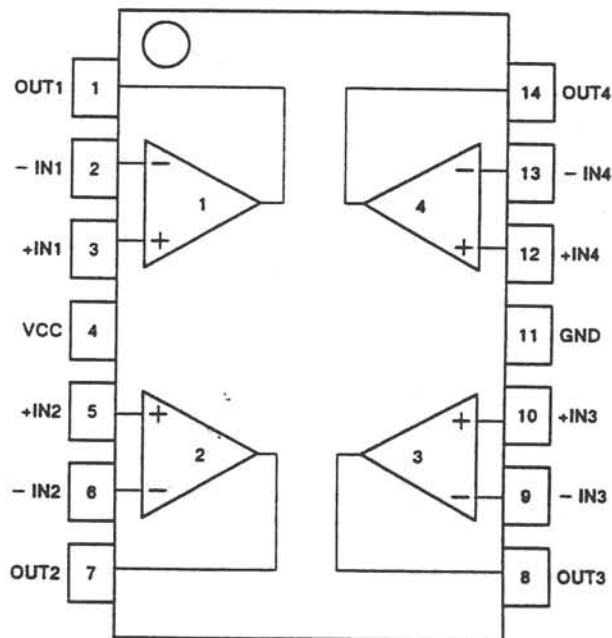

8-3. ELECTRICAL PARTS LIST

Notes: NTSC → GENESIS II
PAL, RGB → MEGA DRIVE II

Circuit No.	Parts No.	Description	Remarks
IC 1	315-0685-A	IC HD68HC000CP8 PLCC HITACHI	
IC 1	315-0686-A	IC MC68HC000FN8 PLCC MOTOROLA	
IC 2	315-0547-10A	IC HM65256BLFP-10 SOP	
IC 2	315-0677-A	IC TC51832FL-10 SOP TOSHIBA	
IC 2	315-0759-85A	IC TC51832AFL-85 SOP TOSHIBA	
IC 2	315-0759-10A	IC TC51832AFL-10 SOP TOSHIBA	
IC 2	315-0760-12A	IC LH59P832N-12 SOP SHARP	NTSC
IC 3	315-0547-10A	IC HM65256BLFP-10 SOP	
IC 3	315-0677-A	IC TC51832FL-10 SOP TOSHIBA	
IC 3	315-0759-85A	IC TC51832AFL-85 SOP TOSHIBA	
IC 3	315-0759-10A	IC TC51832AFL-10 SOP TOSHIBA	
IC 3	315-0760-12A	IC LH59P832N-12 SOP SHARP	NTSC
IC 4	315-0738-R	IC Z84C0006 QFP ZILOG	
IC 4	315-5676-R	IC CUSTOM CHIP UPD9033GB-4-3B4 NEC	PAL,RGB
IC 4	315-0782-R	IC TMPZ84C00AU-6 (QFP) TOSHIBA	PAL,RGB
IC 5	315-0546-A	IC UPD4364G-15L SOP 28P NEC	
IC 5	315-0651-A	IC MB8464A-80 SOP 28P FUJITSU	
IC 5	315-0635-A	IC MB8464A-10LL SOP FUJITSU	
IC 5	315-0753-10A	IC LC3564PM-10L SOP SANYO	
IC 5	315-0753-12A	IC LC3564PM-12L SOP SANYO	
IC 5	315-0754-A	IC KM6264BLG-10 SOP SAMSUNG	
IC 5	315-0755-A	IC KM6264BLG-10L SOP SAMSUNG	
IC 5	315-0766-85	IC LC3664BML-85H SOP SANYO	
IC 5	315-0766-10	IC LC3664BML-10H SOP SANYO	
IC 5	315-0773-A	IC CXK5864CM-70LL-T6 (64K SRAN)	PAL,RGB
IC 6	315-5660-R	IC CUSTOM CHIP FC1004 REV.	
IC 7	315-0515	IC M5M4C264L-12 ZIP MITSUBISHI	NTSC
IC 7	315-0515-15	IC M5M4C264L-15 ZIP MITSUBISHI	
IC 7	315-0453	IC UPD41264V-12 ZIP NEC	
IC 7	315-0423	IC MB81461-12 ZIP FUJITSU	
IC 7	315-0481	IC HM53461ZP-12 ZIP HITACHI	
IC 7	315-0525	IC TMS4461-12SDL ZIP T.I	
IC 7	315-0616	IC V53C261Z10 ZIP VITELIC	
IC 7	315-0622	IC KM424C64Z-10 ZIP SAMSUNG	
IC 7	315-0623	IC MSM51C262-10ZS ZIP OKI	
IC 7	315-5543	IC KM424C64Z-12 ZIP SAMSUNG	
IC 8	315-0515	IC M5M4C264L-12 ZIP MITSUBISHI	
IC 8	315-0515-15	IC M5M4C264L-15 ZIP MITSUBISHI	
IC 8	315-0453	IC UPD41264V-12 ZIP NEC	
IC 8	315-0423	IC MB81461-12 ZIP FUJITSU	
IC 8	315-0481	IC HM53461ZP-12 HITACHI	
IC 8	315-0525	IC TMS4461-12SDL ZIP T.I	
IC 8	315-0616	IC V53C261Z10 ZIP VITELIC	
IC 8	315-0622	IC KM424C64Z-10 ZIP SAMSUNG	

Circuit No.	Parts No.	Description	Remarks
IC 8	315-0623	IC MSM51C262- 10ZS ZIP OKI	
IC 8	315-5543	IC KM424C64Z- 12 ZIP SAMSUNG	
IC 9	313-5063-A	IC LM324 SOP	
IC 9	313-5221-A	IC BA10324AF- T1 SOP ROHM	
IC 10	313-5063-A	IC LM324 SOP	
IC 10	313-5221-A	IC BA10324AF- T1 SOP ROHM	
IC 11	313-5213-A	IC CXA1145M- T6 SOP SONY	NTSC-S
IC 11	313-5232-A	IC MB3514PF- G- BND- EF FUJITU	NTSC-F,PAL,RGB
IC 11	313-5236-A	IC KA2195D SAMSUNG	NTSC-SM
IC 12	313-5214	IC UPC7805HF NEC	
IC 12	313-5230	IC TA7805S TOSHIBA	
OSC 1	230-5053-01D	XTAL OSC 53.693175 MCO- 7020D- 1	NTSC
OSC 1	230-5058-01D	OSC 53.203424M 20PPM SYOWA	PAL,RGB
TR 1	482-0312	XSTR 2SC4177 CHIP M6 M7 NEC	
TR 1	482-0313	XSTR 2SC4081 CHIP ROHM	
TR 2	482-0312	XSTR 2SC4177 CHIP M6 M7 NEC	
TR 2	482-0313	XSTR 2SC4081 CHIP ROHM	
D 1	481-0149-01	DIODE 1S2473 RADIAL	
D 2	481-5038-01	DIODE 1SR- 35- 100A RADIAL	
L 1	NOT USED	NOT USED	
L 2	180-5060	PEAKING COIL 100UH 03TYPE RA	NTSC-F/S, PAL,RGB
L 2	NOT USED	NOT USED	NTSC-SM
L 3	180-5059	PEAKING COIL 12UH 03TYPE RA	NTSC-F/S, PAL,RGB
L 3	NOT USED	NOT USED	NTSC-SM
L 4	NOT USED	NOT USED	
L 5	NOT USED	NOT USED	
L 6	180-5060	PEAKING COIL 100UH 03TYPE RA	PAL,RGB
CF 1	270-5065	COMMON FILTER CM04RC04	
FB 1	271-0044	BEADS INDUCTOR CP BK2125 HS121	
FB 7	271-0043	BEADS INDUCTOR CP BK2125 HS601	
FB 13	271-0043	BEADS INDUCTOR CP BK2125 HS601	
FB 13	271-0044	BEADS INDUCTOR CP BK2125 HS121	PAL,RGB
EM 1	271-0045	EMI FILTER STB101KB	

Circuit No.	Parts No.	Description	Remarks
EM 2	271-0045	EMI FILTER STB101KB	
EM 3	271-0007	EMI FILTER STX222MB	
EM 11	271-0007	EMI FILTER STX222MB	
EM 12	271-0007	EMI FILTER STX222MB	
EM 13	271-0007	EMI FILTER STX222MB	
EM 14	271-0007	EMI FILTER STX222MB	
EM 15	271-0007	EMI FILTER STX222MB	
EM 16	271-0007	EMI FILTER STX222MB	
EM 17	271-0006	EMI FILTER STB271KB	
EM 18	271-0007	EMI FILTER STX222MB	
EM 21	271-0007	EMI FILTER STX222MB	
EM 22	271-0007	EMI FILTER STX222MB	
EM 23	271-0007	EMI FILTER STX222MB	
EM 24	271-0007	EMI FILTER STX222MB	
EM 25	271-0007	EMI FILTER STX222MB	
EM 26	271-0007	EMI FILTER STX222MB	
EM 27	271-0006	EMI FILTER STB271KB	
EM 28	271-0007	EMI FILTER STX222MB	
CE 1	150-0418	CAP E 10UF 16V U- TYPE L=5MM	
CE 2	150-0023	CAP E 10UF 16V U- TYPE 20%	
CE 3	150-0023	CAP E 10UF 16V U- TYPE 20%	
CE 4	150-0023	CAP E 10UF 16V U- TYPE 20%	
CE 5	150-0023	CAP E 10UF 16V U- TYPE 20%	
CE 6	150-0023	CAP E 10UF 16V U- TUPE 20%	
CE 7	150-0023	CAP E 10UF 16V U- TYPE 20%	
CE 8	150-0023	CAP E 10UF 16V U- TYPE 20%	
CE 9	150-0023	CAP E 10UF 16V U- TYPE 20%	
CE 10	150-0023	CAP E 10UF 16V U- TYPE 20%	
CE 11	150-0023	CAP E 10UF 16V U- TYPE 20%	
CE 12	150-0412	CAP E 220UF 6.3V U- TYPE	
CE 14	150-0023	CAP E 10UF 16V U- TYPE 20%	NTSC- S/SM
CE 14	150-0412	CAP E 220UF 6.3V U- TYPE	NTSC- F,PAL,RGB
CE 15	150-0023	CAP E 10UF 16V U- TYPE 20%	
CE 16	150-0159	CAP E 220UF 16V U- TYPE	
CE 17	150-0047	CAP E 100UF 10V U- TYPE	
CE 18	150-0062	CAP E 47UF 10V U- TYPE	
CE 19	150-0062	CAP E 47UF 10V U- TYPE	
CE 20	150-0023	CAP E 10UF 16V U- TYPE 20%	
CE 21	150-0023	CAP E 10UF 16V U- TYPE 20%	
CE 22	150-0023	CAP E 10UF 16V U- TYPE 20%	
CE 23	150-0047	CAP E 100UF 10V U- TYPE	
CE 24	150-0062	CAP E 47UF 10V U- TYPE	
CE 25	150-0062	CAP E 47UF 10V U- TYPE	
CE 26	150-0062	CAP E 47UF 10V U- TYPE	
CE 27	150-0062	CAP E 47UF 10V U- TYPE	
CE 28	150-0062	CAP E 47UF 10V U- TYPE	
CE 29	150-0023	CAP E 10UF 16V U- TYPE 20%	
CE 30	150-0023	CAP E 10UF 16V U- TYPE 20%	
CE 31	150-0023	CAP E 10UF 16V U- TYPE 20%	
CE 32	150-0023	CAP E 10UF 16V U- TYPE 20%	

Circuit No.	Parts No.	Description	Remarks
C 1	NOT USED	NOT USED	
C 2	151-0372	CAP CER CP 33PF 50V CH2125	
C 3	151-0354	CAP CER CP 100PF 50V CH2125	
C 4	NOT USED	NOT USED	
C 5	151-0354	CAP CER CP 100PF 50V CH2125	
C 6	NOT USED	NOT USED	
C 7	NOT USED	NOT USED	
C 8	NOT USED	NOT USED	
C 9	151-0363	CAP CER CHIP 47PF 50V CH2125	PAL,RGB
C 9	NOT USED	NOT USED	NTSC
C 10	151-0289	CAP CER CP 10PF 50V D CH2125	PAL,RGB
C 10	NOT USED	NOT USED	NTSC
C 11	151-0372	CAP CER CP 33PF 50V CH2125	PAL,RGB
C 11	NOT USED	NOT USED	NTSC
C 12	151-0305	CAP CER CP 1000PF 50V KB2125	
C 13	NOT USED	NOT USED	
C 14	151-0305	CAP CER CP 1000PF 50V KB2125	
C 15	NOT USED	NOT USED	
C 16	151-0354	CAP CER CP 100PF 50V CH2125	
C 17	151-0372	CAP CER CP 33PF 50V CH2125	
C 18	151-0354	CAP CER CP 100PF 50V CH2125	
C 19	NOT USED	NOT USED	
C 20	151-0311	CAP CER CP 5600PF 50V KB2125	
C 21	151-0305	CAP CER CP 1000PF 50V KB2125	
C 22	151-0311	CAP CER CP 5600PF 50V KB2125	
C 23	151-0305	CAP CER CP 1000PF 50V KB2125	
C 24	151-0312	CAP CER CP 0.01UF 50V KB2125	
C 25	151-0307	CAP CER CP 0.022UF 50V ZF2125	
C 26	151-0307	CAP CER CP 0.022UF 50V ZF2125	
C 27	151-0307	CAP CER CP 0.022UF 50V ZF2125	
C 28	151-0308	CAP CER CP 18PF 50V CH2125	NTSC-F/S, PAL,RGB
C 28	NOT USED	NOT USED	NTSC-SM
C 29	151-0312	CAP CER CP 0.01UF 50V KB2125	NTSC-F/S, PAL,RGB
C 29	NOT USED	NOT USED	NTSC-SM
C 30	151-0309	CAP CER CP 180PF 50V CH2125	NTSC-F/S, PAL,RGB
C 30	NOT USED	NOT USED	NTSC-SM
C 31	151-0354	CAP CER CP 100PF 50V CH2125	
C 32	151-0309	CAP CER CP 180PF 50V CH2125	NTSC-S
C 32	151-0361	CAP CER CP 15PF 50V CH2125	NTSC-F,PAL,RGB

Circuit No.	Parts No.	Description	Remarks
C 32	NOT USED	NOT USED	NTSC - SM
C 33	NOT USED	NOT USED	
C 34	NOT USED	NOT USED	
C 35	151-0265	CAP CER CP 0.1UF 25V ZF2125	
C 36	151-0265	CAP CER CP 0.1UF 25V ZF2125	
C 37	151-0307	CAP CER CP 0.022UF 50V ZF2125	
C 38	151-0307	CAP CER CP 0.022UF 50V ZF2125	
C 39	151-0307	CAP CER CP 0.022UF 50V ZF2125	
C 40	151-0307	CAP CER CP 0.022UF 50V ZF2125	
C 41	151-0307	CAP CER CP 0.022UF 50V ZF2125	
C 42	151-0307	CAP CER CP 0.022UF 50V ZF2125	
C 43	151-0307	CAP CER CP 0.022UF 50V ZF2125	
C 44	151-0307	CAP CER CP 0.022UF 50V ZF2125	
C 45	151-0307	CAP CER CP 0.022UF 50V ZF2125	
C 46	151-0307	CAP CER CP 0.022UF 50V ZF2125	
C 47	151-0307	CAP CER CP 0.022UF 50V ZF2125	
C 48	151-0307	CAP CER CP 0.022UF 50V ZF2125	
C 49	151-0307	CAP CER CP 0.022UF 50V ZF2125	
C 50	151-0307	CAP CER CP 0.022UF 50V ZF2125	
C 51	151-0307	CAP CER CP 0.022UF 50V ZF2125	
C 52	151-0307	CAP CER CP 0.022UF 50V ZF2125	
C 53	151-0307	CAP CER CP 0.022UF 50V ZF2125	
C 54	151-0307	CAP CER CP 0.022UF 50V ZF2125	
C 55	151-0307	CAP CER CP 0.022UF 50V ZF2125	
C 56	151-0311	CAP CER CP 5600PF 50V KB2125	
C 57	NOT USED	NOT USED	NTSC - S/SM
C 57	151-0354	CAP CER CP 100PF 50V CH2125	NTSC - F,PAL,RGB
C 58	151-0311	CAP CER CP 5600PF 50V KB2125	
C 59	151-0307	CAP CER CP 0.022UF 50V ZF2125	
C 60	NOT USED	NOT USED	
C 61	151-0265	CAP CER CP 0.1UF 25V ZF2125	PAL,RGB
C 62	151-0336	CAP CER CHIP 12PF 50V CH2125	PAL,RGB
CA 1	151-0401	C - PACK CP 33P*16 W/COMMON TDK	
R 9	476-2121-J-10	RES CHIP 120 OHM 1/10W 5%	
R 10	476-2222-J-10	RES CHIP 2.2kOHM 1/10W 5%	
R 11	476-2472-J-10	RES CHIP 4.7kOHM 1/10W 5%	
R 12	476-2222-J-10	RES CHIP 2.2kOHM 1/10W 5%	
R 13	NOT USED	NOT USED	
R 14	476-2122-J-10	RES CHIP 1.2kOHM 1/10W 5%	
R 15	476-2222-J-10	RES CHIP 2.2kOHM 1/10W 5%	
R 18	NOT USED	NOT USED	
R 21	476-2222-J-10	RES CHIP 2.2kOHM 1/10W 5%	
R 22	476-2103-J-10	RES CHIP 10kOHM 1/10W 5%	
R 23	476-2103-J-10	RES CHIP 10kOHM 1/10W 5%	
R 24	476-2103-J-10	RES CHIP 10kOHM 1/10W 5%	
R 25	476-2103-J-10	RES CHIP 10kOHM 1/10W 5%	

Circuit No.	Parts No.	Description	Remarks
R 26	476-2100-J-10	RES CHIP 10 OHM 1/10W 5%	
R 27	476-2151-J-10	RES CHIP 150 OHM 1/10W 5%	
R 28	476-2102-J-10	RES CHIP 1kOHM 1/10W 5%	
R 29	476-2100-J-10	RES CHIP 10 OHM 1/10W 5%	
R 30	476-2151-J-10	RES CHIP 150 OHM 1/10W 5%	
R 31	476-2102-J-10	RES CHIP 1kOHM 1/10W 5%	
R 32	476-2473-J-10	RES CHIP 47kOHM 1/10W 5%	
R 33	476-2513-J-10	RES CHIP 51kOHM 1/10W 5%	
R 34	476-2153-J-10	RES CHIP 15kOHM 1/10W 5%	
R 35	476-2473-J-10	RES CHIP 47kOHM 1/10W 5%	
R 36	476-2513-J-10	RES CHIP 51kOHM 1/10W 5%	
R 37	476-2153-J-10	RES CHIP 15kOHM 1/10W 5%	
R 38	476-2473-J-10	RES CHIP 47kOHM 1/10W 5%	
R 39	476-2473-J-10	RES CHIP 47kOHM 1/10W 5%	
R 40	476-2750-J-10	RES CHIP 75 OHM 1/10W 5%	
R 41	476-2750-J-10	RES CHIP 75 OHM 1/10W 5%	
R 42	476-2472-J-10	RES CHIP 4.7kOHM 1/10W 5%	
R 43	476-2472-J-10	RES CHIP 4.7kOHM 1/10W 5%	
R 44	476-2472-J-10	RES CHIP 4.7kOHM 1/10W 5%	
R 45	476-2472-J-10	RES CHIP 4.7kOHM 1/10W 5%	
R 46	476-2752-J-10	RES CHIP 7.5kOHM 1/10W 5%	
R 47	476-2122-J-10	RES CHIP 1.2kOHM 1/10W 5%	NTSC-S
R 47	476-2123-J-10	RES CHIP 12kOHM 1/10W 5%	NTSC-F,PAL,RGB
R 47	NOT USED	NOT USED	NTSC-SM
R 48	476-2222-J-10	RES CHIP 2.2kOHM 1/10W 5%	
R 49	476-2750-J-10	RES CHIP 75 OHM 1/10W 5%	
R 50	476-2562-J-10	RES CHIP 5.6kOHM 1/10W 5%	
R 51	476-2562-J-10	RES CHIP 5.6kOHM 1/10W 5%	
R 52	476-2562-J-10	RES CHIP 5.6kOHM 1/10W 5%	
R 53	476-2102-J-10	RES CHIP 1kOHM 1/10W 5%	
R 54	476-2243-J-10	RES CHIP 24kOHM 1/10W 5%	NTSC-S/SM
R 54	NOT USED	NOT USED	NTSC-F,PAL,RGB
R 55	476-2102-J-10	RES CHIP 1kOHM 1/10W 5%	NTSC-S
R 55	476-2103-J-10	RES CHIP 10kOHM 1/10W 5%	NTSC-F,PAL,RGB
R 55	NOT USED	NOT USED	NTSC-SM
R 56	476-2122-J-10	RES CHIP 1.2kOHM 1/10W 5%	NTSC-F/S, PAL,RGB
R 56	NOT USED	NOT USED	NTSC-SM
R 57	476-2102-J-10	RES CHIP 1kOHM 1/10W 5%	PAL,RGB
R 57	476-2331-J-10	RES CHIP 330 OHM 1/10W 5%	NTSC-F/S
R 57	NOT USED	NOT USED	NTSC-SM
R 58	476-2122-J-10	RES CHIP 1.2kOHM 1/10W 5%	
R 59	476-2122-J-10	RES CHIP 1.2kOHM 1/10W 5%	
R 60	476-2122-J-10	RES CHIP 1.2kOHM 1/10W 5%	

Circuit No.	Parts No.	Description	Remarks
R 61	476-2103-J-10	RES CHIP 10kOHM 1/10W 5%	NTSC - S/SM NTSC - F,PAL,RGB
R 61	476-2472-J-10	RES CHIP 4.7kOHM 1/10W 5%	
R 62	476-2472-J-10	RES CHIP 4.7kOHM 1/10W 5%	
R 63	476-2472-J-10	RES CHIP 4.7kOHM 1/10W 5%	
R 64	476-2472-J-10	RES CHIP 4.7kOHM 1/10W 5%	
R 65	476-2473-J-10	RES CHIP 47kOHM 1/10W 5%	
R 66	476-2103-J-10	RES CHIP 10kOHM 1/10W 5%	
R 67	476-2104-J-10	RES CHIP 100kOHM 1/10W 5%	
R 68	476-2331-J-10	RES CHIP 330 OHM 1/10W 5%	
R 69	476-2331-J-10	RES CHIP 330 OHM 1/10W 5%	
R 70	476-2331-J-10	RES CHIP 330 OHM 1/10W 5%	
R 71	476-2331-J-10	RES CHIP 330 OHM 1/10W 5%	
R 72	476-2102-J-10	RES CHIP 1kOHM 1/10W 5%	
R 73	476-2102-J-10	RES CHIP 1kOHM 1/10W 5%	
R 74	476-2151-J-10	RES CHIP 150 OHM 1/10W 5%	
R 75	476-2221-J-10	RES CHIP 220 OHM 1/10W 5%	
R 76	476-2752-J-10	RES CHIP 7.5kOHM 1/10W 5%	
R 77	476-2103-J-10	RES CHIP 10kOHM 1/10W 5%	
R 78	476-2103-J-10	RES CHIP 10kOHM 1/10W 5%	
R 79	476-2331-J-10	RES CHIP 330 OHM 1/10W 5%	
R 80	476-2331-J-10	RES CHIP 330 OHM 1/10W 5%	
R 81	476-2682-J-10	RES CHIP 6.8kOHM 1/10W 5%	
R 82	479-5005-0000	RES CHIP 0 OHM 1/10W 5%	
R 83	479-5005-0000	RES CHIP 0 OHM 1/10W 5%	
RA 1	477-0136	R- PACK CHIP 4*100 OHM 1/16W 5%	
RA 2	477-0136	R- PACK CHIP 4*100 OHM 1/16W 5%	
RA 3	477-0139	R- PACK CHIP 2*100 OHM 1/16W 5%	
RA 4	477-0136	R- PACK CHIP 4*100 OHM 1/16W 5%	
RA 5	477-0136	R- PACK CHIP 4*100 OHM 1/16W 5%	
RA 6	477-0136	R- PACK CHIP 4*100 OHM 1/16W 5%	
RA 7	477-0132	R- PACK CHIP 8*4.7kOHM W/COMM.	
RA 8	477-0148	R- PACK CHIP 4*2.2kOHM W/COMM.	
LED 1	390-5234	LED GL3PR8	
S 1	510-5019	TACTILE PUSH SW SKEVAA	
S 1	509-5207	TACT SW SKEVAA ALPS	
S 2	510-5046	PUSH SWITCH JPK0010- Z091 SMK	
CN 1	212-5364	MINI DIN CONN 9P TCS7913- 43	
CN 3	209-5061	EDGE CONNECTOR 64P PSB4D32K- 7R	
CN 5	209-5066	D- SUB 9P*2 UC0082- 21#10- 0	
CN 7	212-5353	CONN DC JACK EIAJ3 HEC3100	
EYLET CN3L	079-000003	EYLET 3.5*7	
EYLET CN3L	079-000005	EYLET 6*3.5*8	
EYLET CN3R	079-000003	EYLET 3.5*7	

Circuit No.	Parts No.	Description	Remarks
EYLET CN3R	079-000005	EYLET 6*3.5*8	
TS CN5L	012-P00308	TAP SCR PH 3 × 8	
EYLET CN5L	079-000001	EYLET 2.3*7	
TS CN5C	012-P00308	TAP SCR PH 3 × 8	
EYLET CN5C	079-000001	EYLET 2.3*7	
TS CN5R	012-P00308	TAP SCR PH 3 × 8	
EYLET CN5R	079-000001	EYLET 2.3*7	

8-4. ACCESSORIES/PACKAGE LIST

For GENESIS II

Symbol No.	Parts No.	Description	Remarks
1	610-5571-01	ASSY CP M5 USA (CONTROL PAD)	
2	400-5135A	AC ADAPTOR AC120V/DC10V 0.85A	
2	400-5135A-01	AC ADAPTOR AC120V/DC10V 0.85A	
2	400-5135A-02	AC ADAPTOR AC120V/DC10V 0.85A	
2	400-5135A-03	AC ADAPTOR AC120V/DC10V 0.85A	
3	610-5472	RF UNIT GEN2 MDU-VA3431	
3	610-5472-01	RF UNIT GEN2 MDQT2A801A	
3	610-5472-02	RF UNIT GEN2 TOWA NTSC	
5	672-1208	OPERATION MANUAL GEN2 USA	
6	671-3379-01	BOX & PACK SET GEN2 USA 1630L	MK-1630
6	671-3379-02	BOX & PACK SET GEN2 USA 1614L	MK-1614
7	671-3373-01	MA CTN GEN2 USA 1630L	MK-1630
7	671-3373-02	MA CTN GEN2 USA 1614L	MK-1614
8	SGM-4216	POLY BAG 260 × 320 × 0.05 EXP 6	
9	SGM-4217	POLY BAG 200 × 300 × 0.05 EXP 6	
10	670-0483	GAME CATALOG GEN	
11	670-3264	BUSINESS REPLY MAIL GEN2 USA	
12	670-3265	CROSS SELL POSTER GNE2 USA	
13	670-3284	PARTS ORDER FORM GEN2 USA	

NOTE:
ACCESSORY PROVIDED

MODEL No.	MK-1614	MK-1630
SONIC 2 CARTRIDGE	YES	NO

For MEGA DRIVE II

Symbol No.	Parts No.	Description	Remarks
1	610-5372-01	ASSY CP M5 REV. EUR SE (CONTROL PAD)	
1	610-5376-01	ASSY CP M5 REV. EUR EFA (CONTROL PAD)	
2	400-5211	AC ADAPTOR AC240V/DC9V 0.85A	AUSTRALIA, NEW ZEALAND
2	400-5208	AC ADAPTOR AC240V/DC9V 0.85A	U. K
2	400-5209	AC ADAPTOR AC230V 50Hz/DC10V 0.85A	Except U. K, AUSTRALIA AND NEW ZEALAND
3	610-5493	RF UNIT MD2 PAL - B	NEW ZEALAND
3	610-5473	RF UNIT MD2 MDU- UD3631	Except
3	610-5473-01	RF UNIT MD2 MDQT4E801A	NEW ZEALAND,
3	610-5473-02	RF UNIT MD2 TOWA PAL - G/I	FRANCE
4	600-6273	RGB CABLE MD2 UNION (PERITEL CABLE)	FRANCE, SAUDI ARABIA
5	672-1209	OPERATION MANUAL MD2 MULTI	Except
5	672-1328	OPERATION MANUAL MD2 KSA	SAUDI ARABIA SAUDI ARABIA
6	671-3127-02	BOX & PACK SET MD2 MULTI 1630	MK-1630
6	671-3127-04	BOX & PACK SET MD2 MULTI 1685	MK-1685
6	671-3127-05	BOX & PACK SET MD2 MULTI 1686	MK-1686
6	671-3127-06	BOX & PACK SET MD2 MULTI 1695	MK-1695
7	671-3124-02	MA CTN MD2 MULTI 1630	MK-1630
7	671-3124-04	MA CTN MD2 MULTI 1685	MK-1685
7	671-3124-05	MA CTN MD2 MULTI 1686	MK-1686
7	671-3124-06	MA CTN MD2 MULTI 1695	MK-1695
8	SGM-4216	POLY BAG 260 × 320 × 0.05 EXP 6	
9	SGM-4217	POLY BAG 200 × 300 × 0.05 EXP 6	
10	670-0740	GAME CATALOG 16 MULTI	
11	670-3330	GUARANTEE CARD SOE MD2 FRG & ESP	GERMAN, SPAIN
11	670-3331	GUARANTEE CARD SOE MD2 FRA	FRANCE
11	670-3332	GUARANTEE CARD SOE MD2 GBR	U. K
11	670-3381	GUARANTEE CARD MD2 ITA	ITALY
11	670-3327	GUARANTEE CARD OZISOFT MD2	AUSTRALIA, NEW ZEALAND

NOTE:
ACCESSORY PROVIDED

MODEL No.	MK-1630	MK-1685	MK-1686	MK-1695
SONIC 2 CARTRIDGE	0	1	1	0
MEGA GENESIS 1 CARTRIDGE	0	0	1	0
CONTROL PAD	1	2	1	2



4. BLOCK DIAGRAM

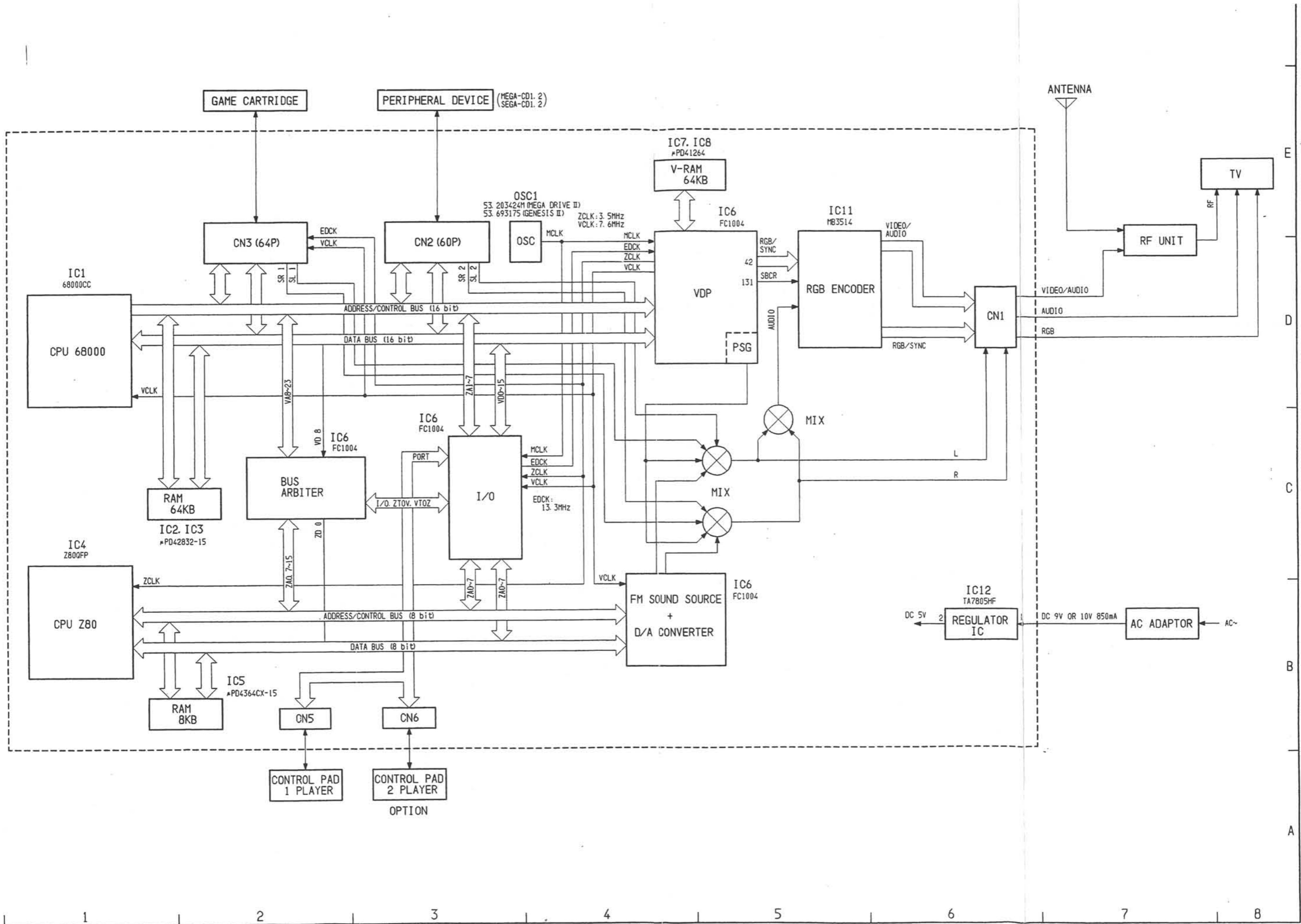

5. SCHEMATIC DIAGRAMS

5-1. SCHEMATIC DIAGRAM-1

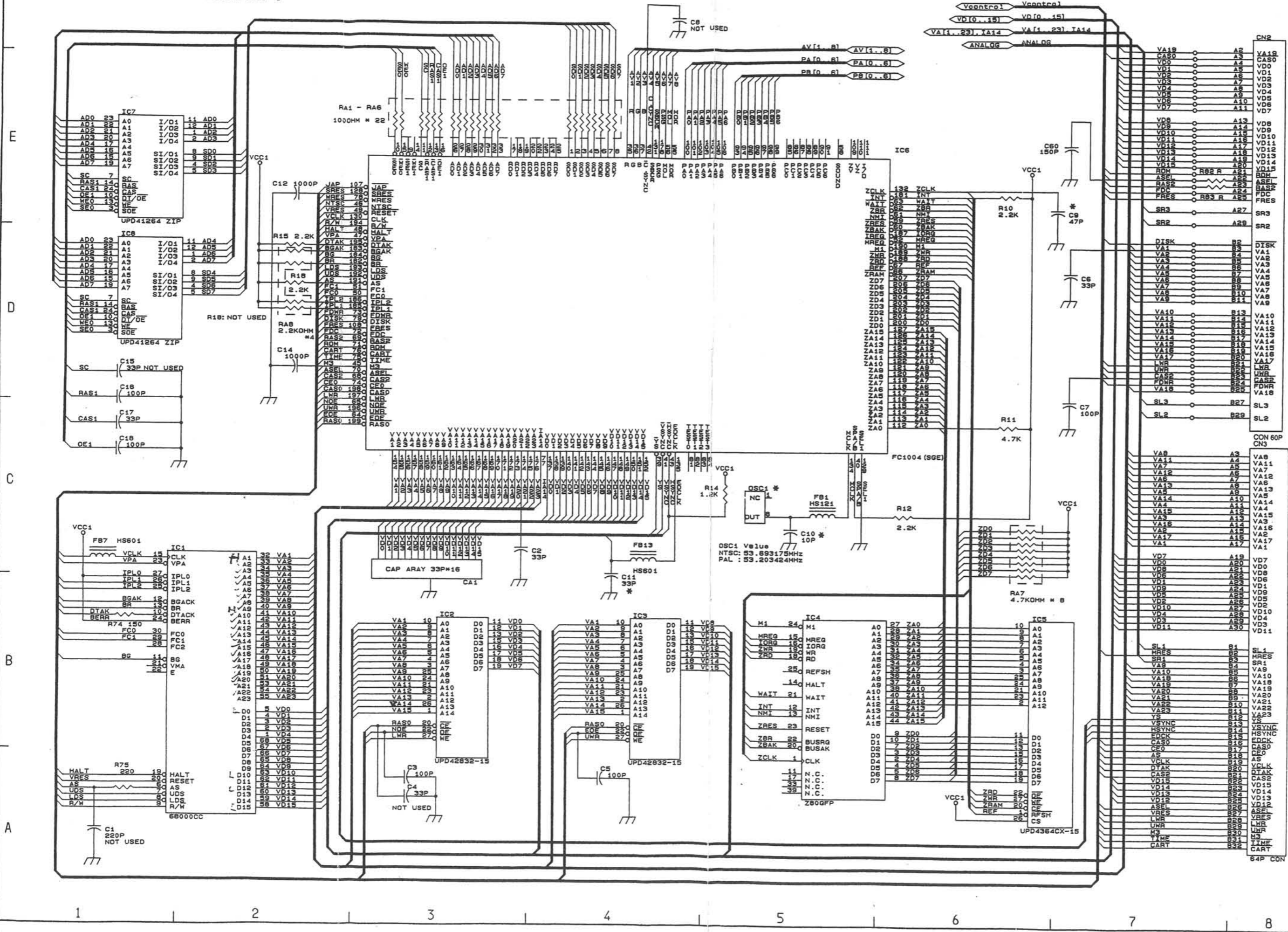

5-4. SCHEMATIC DIAGRAM-4

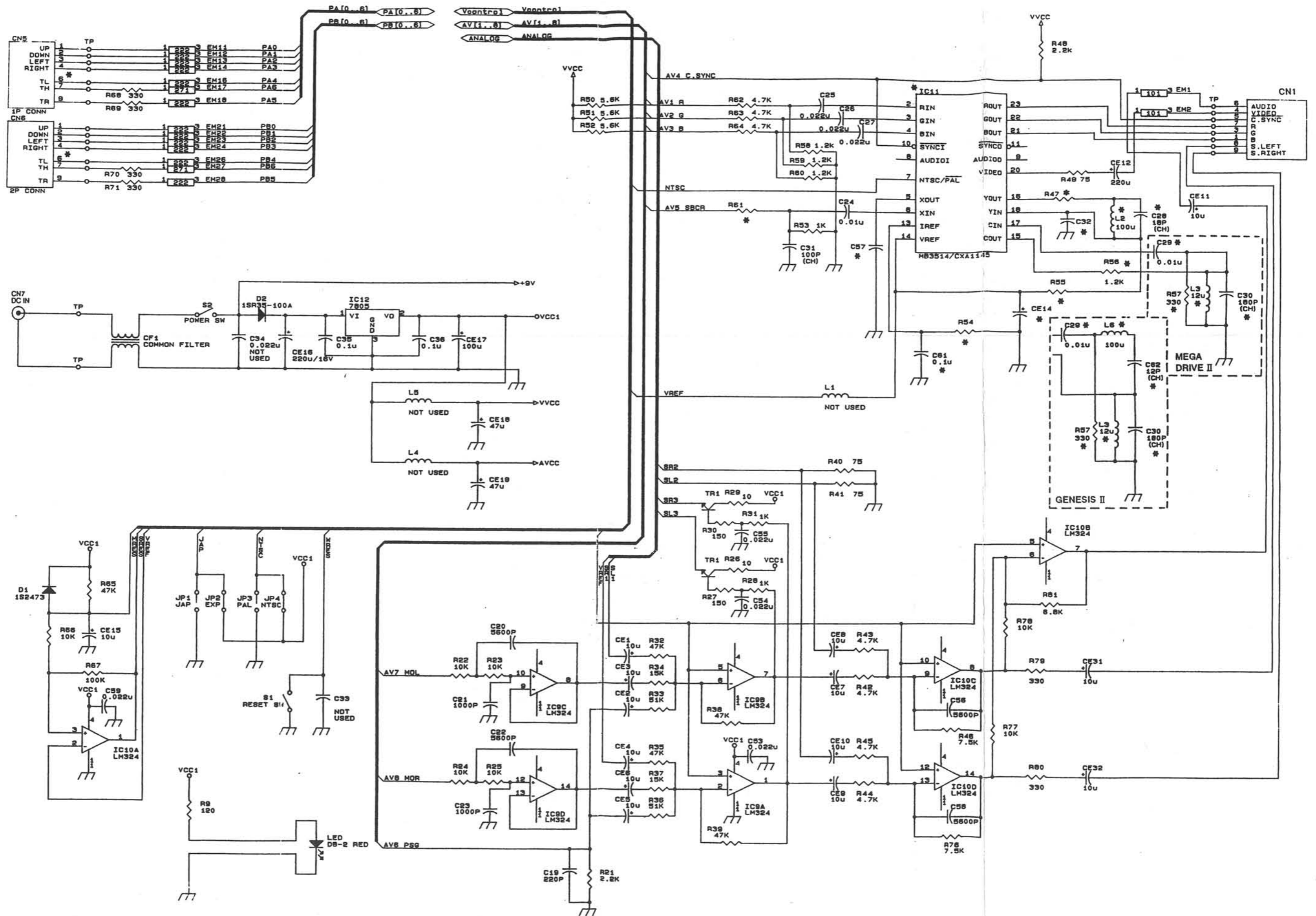

6. CIRCUIT BOARD DIAGRAMS

6-1. MAIN CIRCUIT BOARD (Top View) —For GENESIS II —

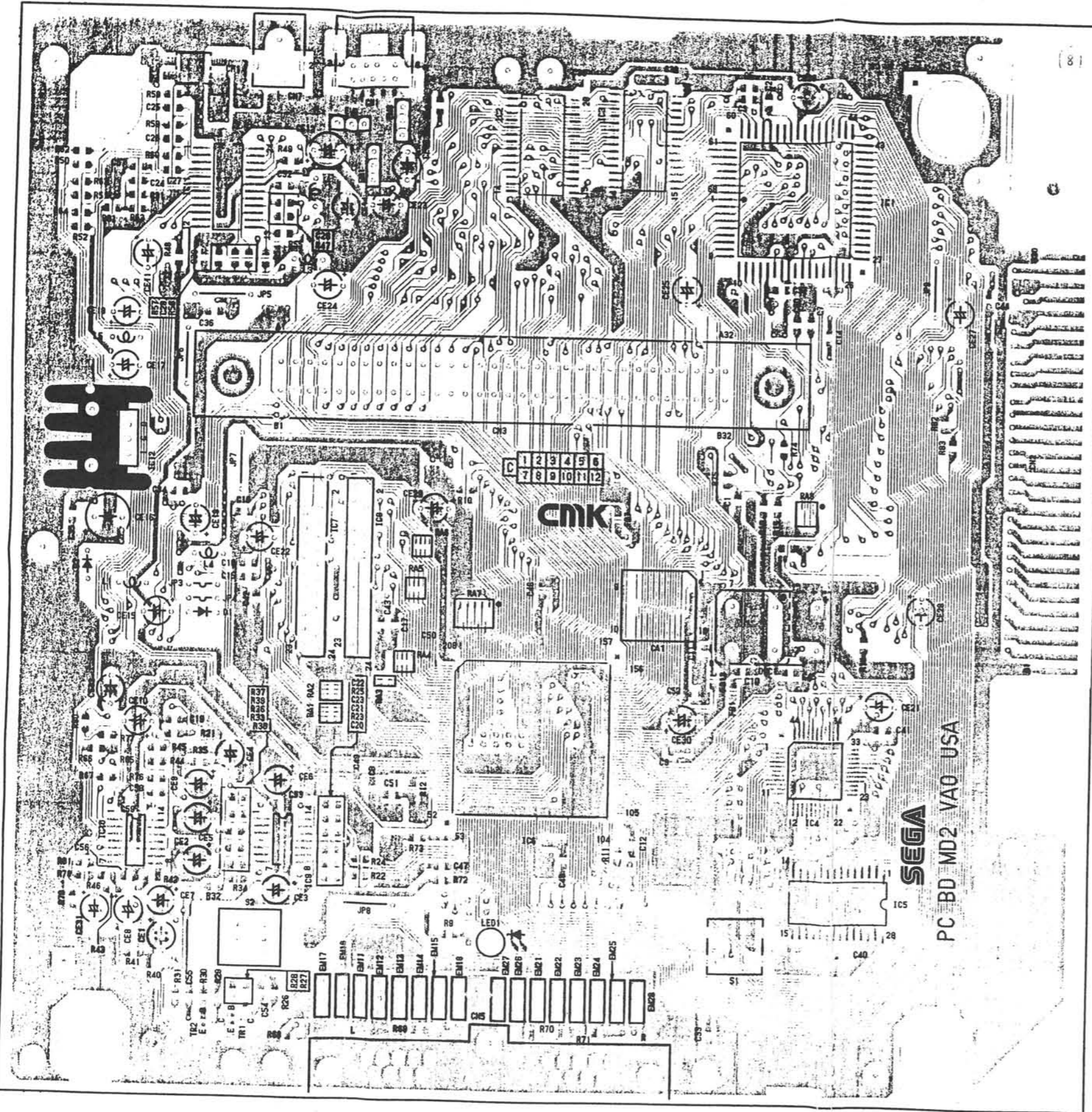

* DIFFERENCE TABLE

CIRCUIT No.	GENESIS II		
	TYPE-F	TYPE-S	TYPE-SM
L2	○	○	×
L3	○	○	×
L6	×	×	×
C9	×	×	×
C10	×	×	×
C11	×	×	×
C28	○	○	×
C29	○	○	×
C30	○	○	×
C32	○	○	×
C57	○	×	×
C61	×	×	×
C62	×	×	×
R47	○	○	×
R54	×	○	○
R55	○	○	×
R56	○	○	×
R57	○	○	×

× : NOT MOUNTED

○ : MOUNTED

6-2. MAIN CIRCUIT BOARD (Bottom View) —For GENESIS II —

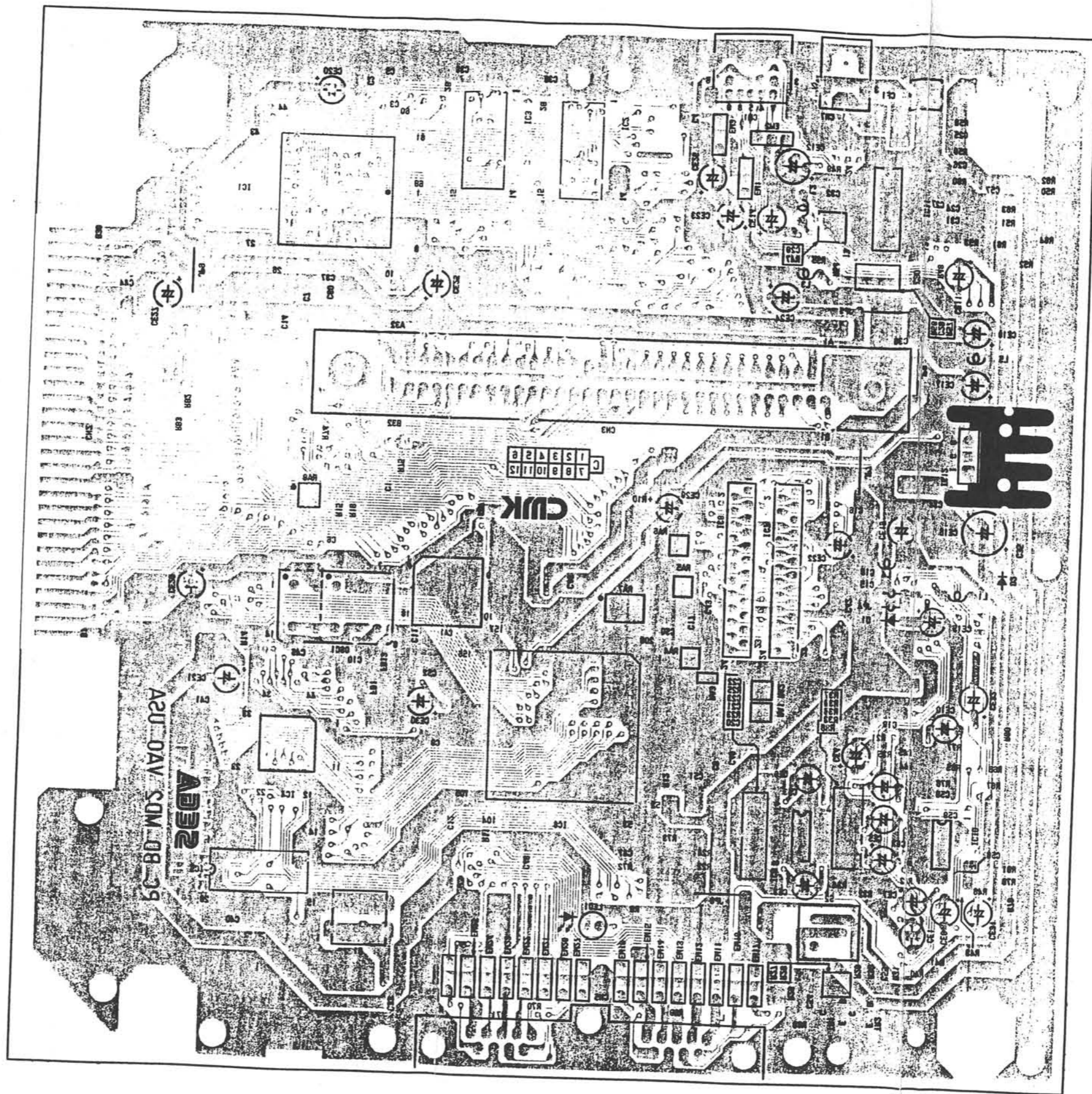

1 2 3 4 5 6 7

A B C D E

6-3. MAIN CIRCUIT BOARD (Top View) —For MEGA DRIVE II —

E

D

C

B

A

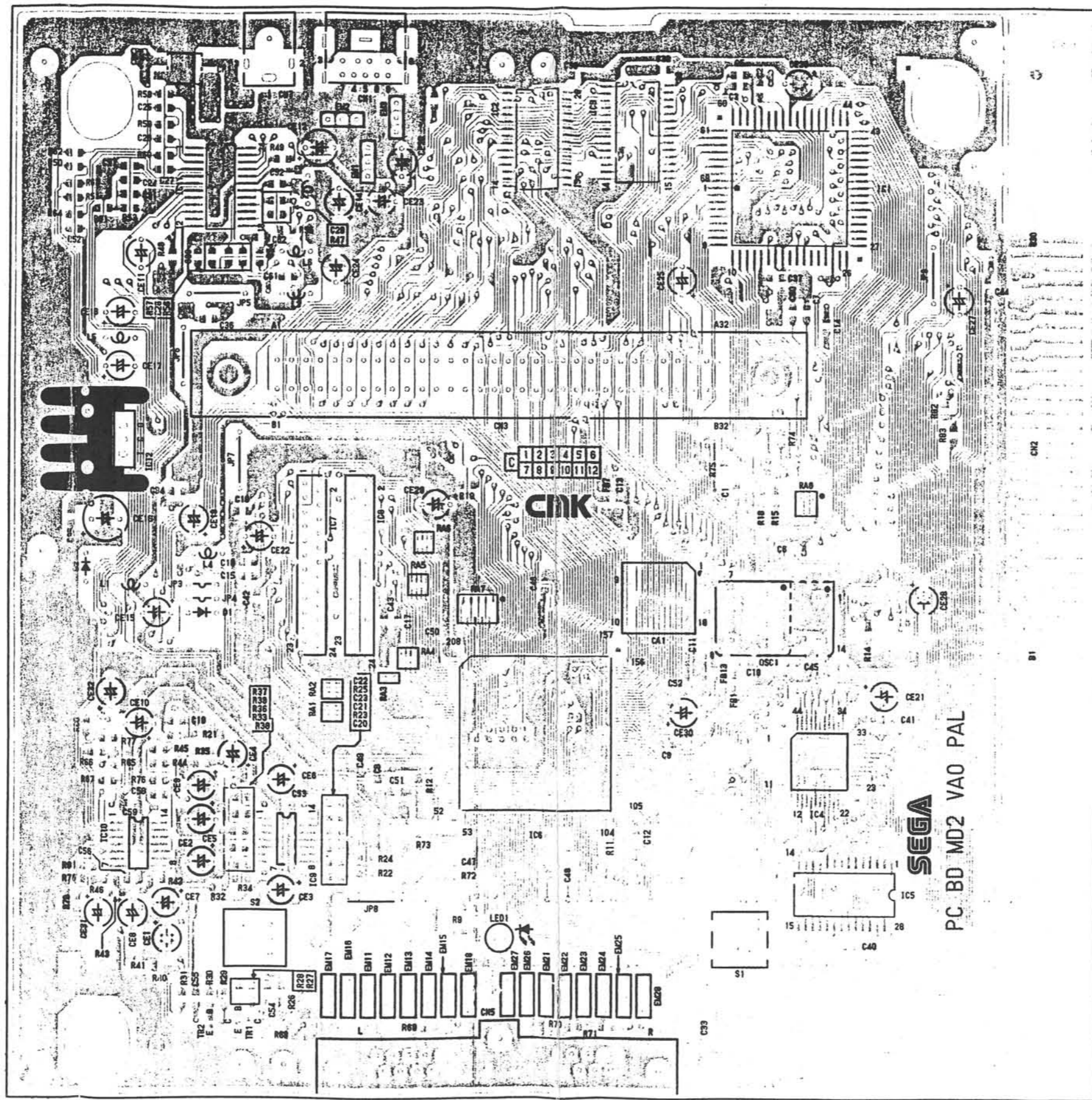

SEGA
PC BD MD2 VA0 PAL

1

2

3

4

5

6

7

8

6-4. MAIN CIRCUIT BOARD (Bottom View) —For MEGA DRIVE II —

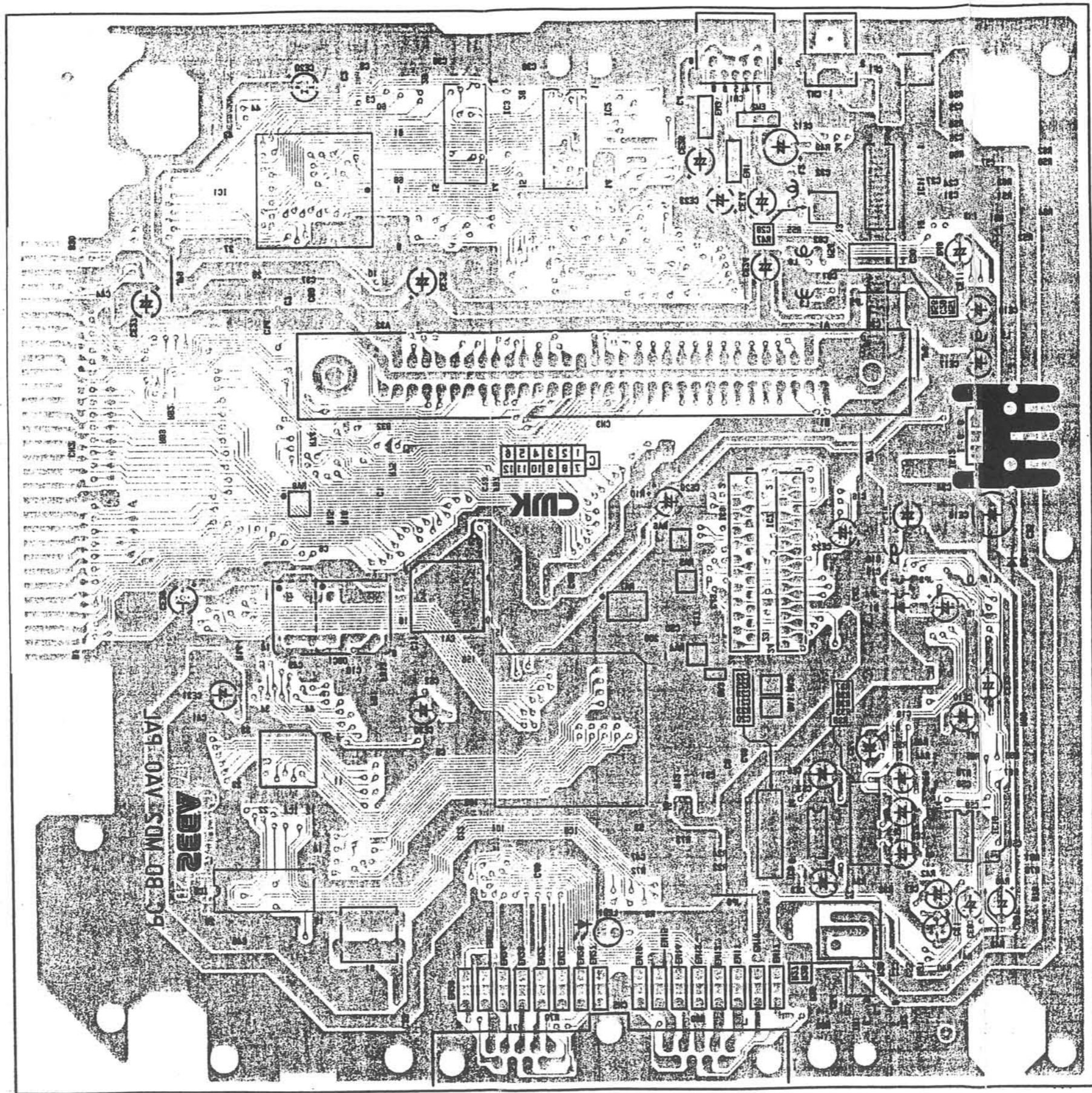

7. PARTS SPECIFICATION

IC1 IC HD68HC000CP8
Parts No. : 315-0685-A

IC MC68HC000FN8
Parts No. : 315-0686-A

■ Outside View

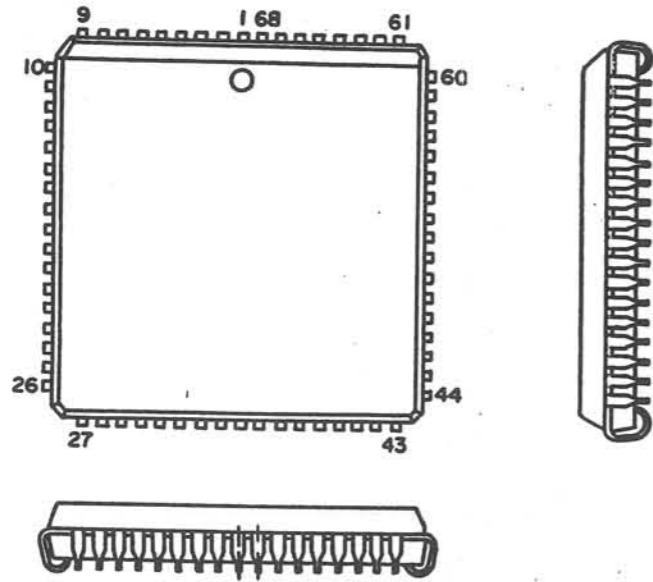

■ Description

Pin No.	Name	I/O	Function	Pin No.	Name	I/O	Function
1	N/C	-	N/C	21	A ₁₆	O	Address Bus 16.
2	\overline{DTACK}	I	Data Transfer Acknowledge.	22	A ₁₇	O	Address Bus 17.
3	\overline{BGACK}	I	Bus Grant Acknowledge.	23	A ₁₉	O	Address Bus 19.
4	\overline{BR}	I	Bus Request.	24	A ₂₀	O	Address Bus 20.
5	CLK	I	Clock.	25	A ₂₁	O	Address Bus 21.
6	\overline{HALT}	I/O	Halt.	26	A ₂₂	O	Address Bus 22.
7	\overline{VMA}	O	Valid Memory Address.	27	D ₁₅	I/O	Data bus 15.
8	E	O	Enable.	28	D ₁₂	I/O	Data bus 12.
9	\overline{BERR}	I	Bus Error.	29	D ₁₀	I/O	Data bus 10.
10	N/C	-	N/C	30	D ₈	I/O	Data bus 8.
11	FC ₂	O	Function Code Output 2.	31	D ₇	I/O	Data bus 7.
12	FC ₀	O	Function Code Output 0.	32	D ₅	I/O	Data bus 5.
13	A ₁	O	Address Bus 1.	33	D ₄	I/O	Data bus 4.
14	A ₃	O	Address Bus 3.	34	D ₂	I/O	Data bus 2.
15	A ₄	O	Address Bus 4.	35	D ₁	I/O	Data bus 1.
16	A ₆	O	Address Bus 6.	36	\overline{AS}	O	Address Strobe.
17	A ₇	O	Address Bus 7.	37	\overline{LDS}	O	Lower Data Strobe.
18	A ₉	O	Address Bus 9.	38	\overline{BG}	O	Bus Grant.
19	N/C	-	N/C	39	V _{CC}	I	Power Input.
20	A ₁₄	O	Address Bus 14.	40	V _{SS}	I	GND.

Pin No.	Name	I/O	Function
41	\overline{RES}	I/O	Reset
42	\overline{VPA}	I	Valid Peripheral Address.
43	\overline{IPL}_2	I	Interrupt Priority Level 2.
44	\overline{IPL}_0	I	Interrupt Priority Level 0.
45	FC ₁	O	Function Code Output 1.
46	N/C	-	N/C
47	A ₂	O	Address Bus 2.
48	A ₅	O	Address Bus 5.
49	A ₈	O	Address Bus 8.
50	A ₁₀	O	Address Bus 10.
51	A ₁₁	O	Address Bus 11.
52	A ₁₂	O	Address Bus 12.
53	A ₁₅	O	Address Bus 15.
54	A ₁₈	O	Address Bus 18.
55	V _{CC}	I	Power Input.
56	V _{SS}	I	GND.
57	A ₂₃	O	Address Bus 23.
58	D ₁₄	I/O	Data bus 14.
59	D ₁₁	I/O	Data bus 11.
60	D ₉	I/O	Data bus 9.
61	D ₆	I/O	Data bus 6.
62	D ₃	I/O	Data bus 3.
63	D ₀	I/O	Data bus 0.
64	\overline{UDS}	O	Upper Data Strobe.
65	$\overline{R/W}$	O	Read/Write.
66	\overline{IPL}_1	I	Interrupt Priority Level 1.
67	A ₁₃	O	Address Bus 13.
68	D ₁₃	I/O	Data Bus 13.

IC11 IC MB3514PF-G-BND-EF
Parts No. : 313-5232-A

IC CXA1145M-T6
Parts No. : 313-5213-A

IC KA2195D
Parts No. : 313-5236-A

■ Outside View

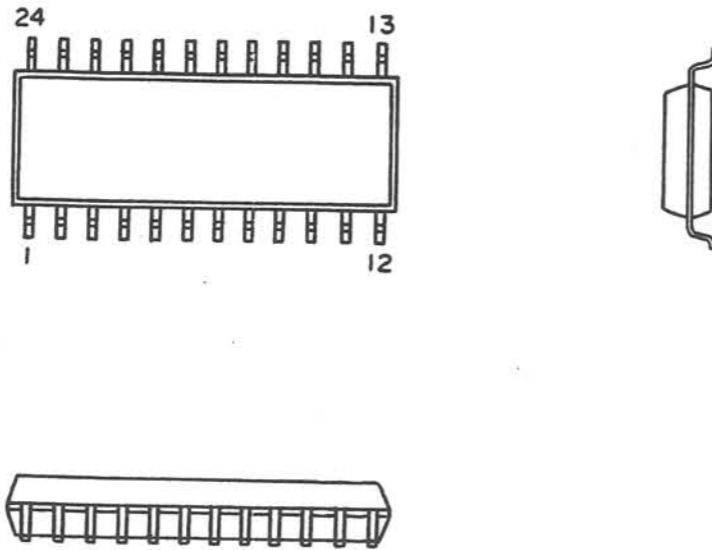

■ Pin Layout

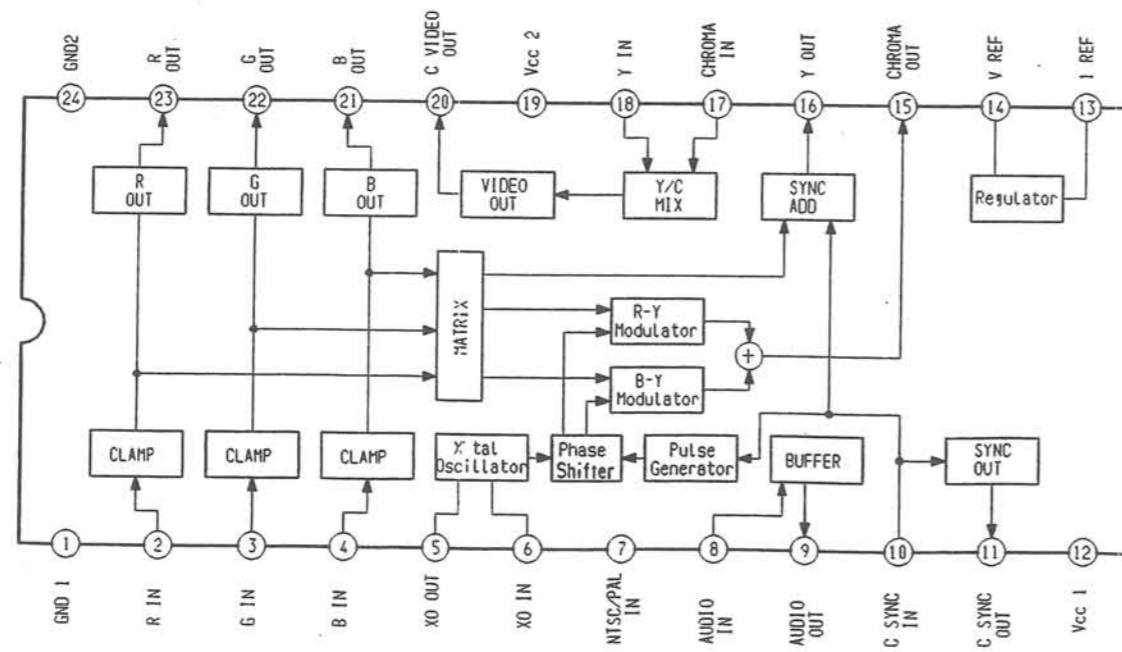

IC12 IC UPC7805HF
Parts No. : 313-5214

IC TA7805S
Parts No. : 313-5230

■ Outside View

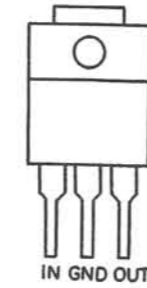

■ Equivalent Block Diagram

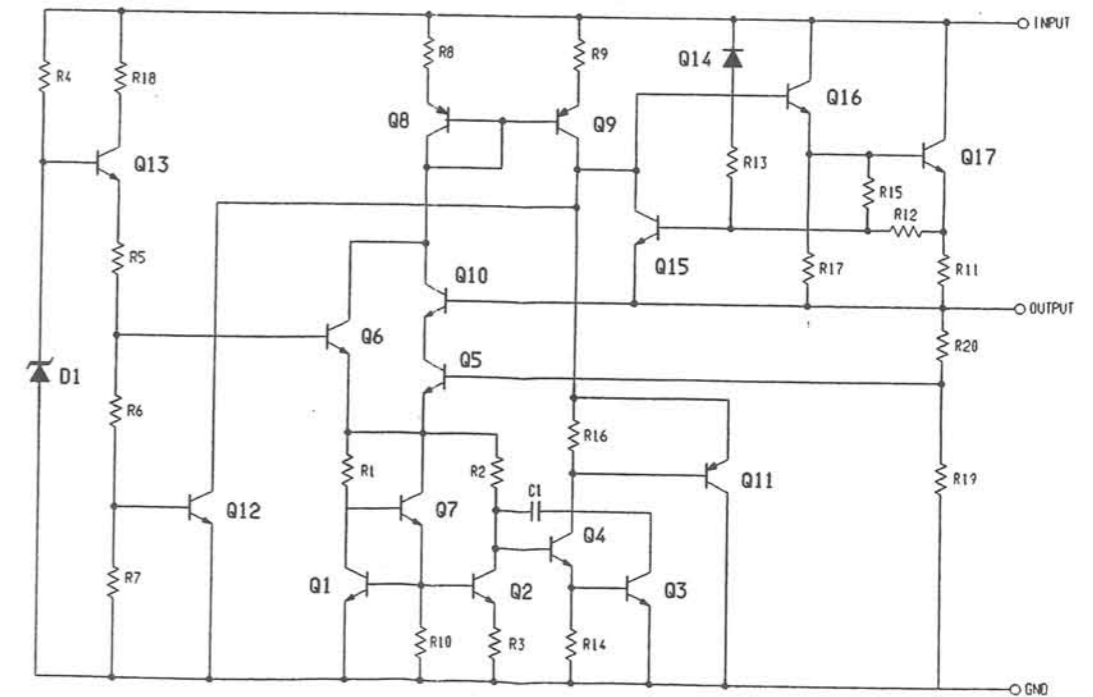

8. EXPLODED VIEW & PARTS LIST

8-1. EXPLODED VIEW

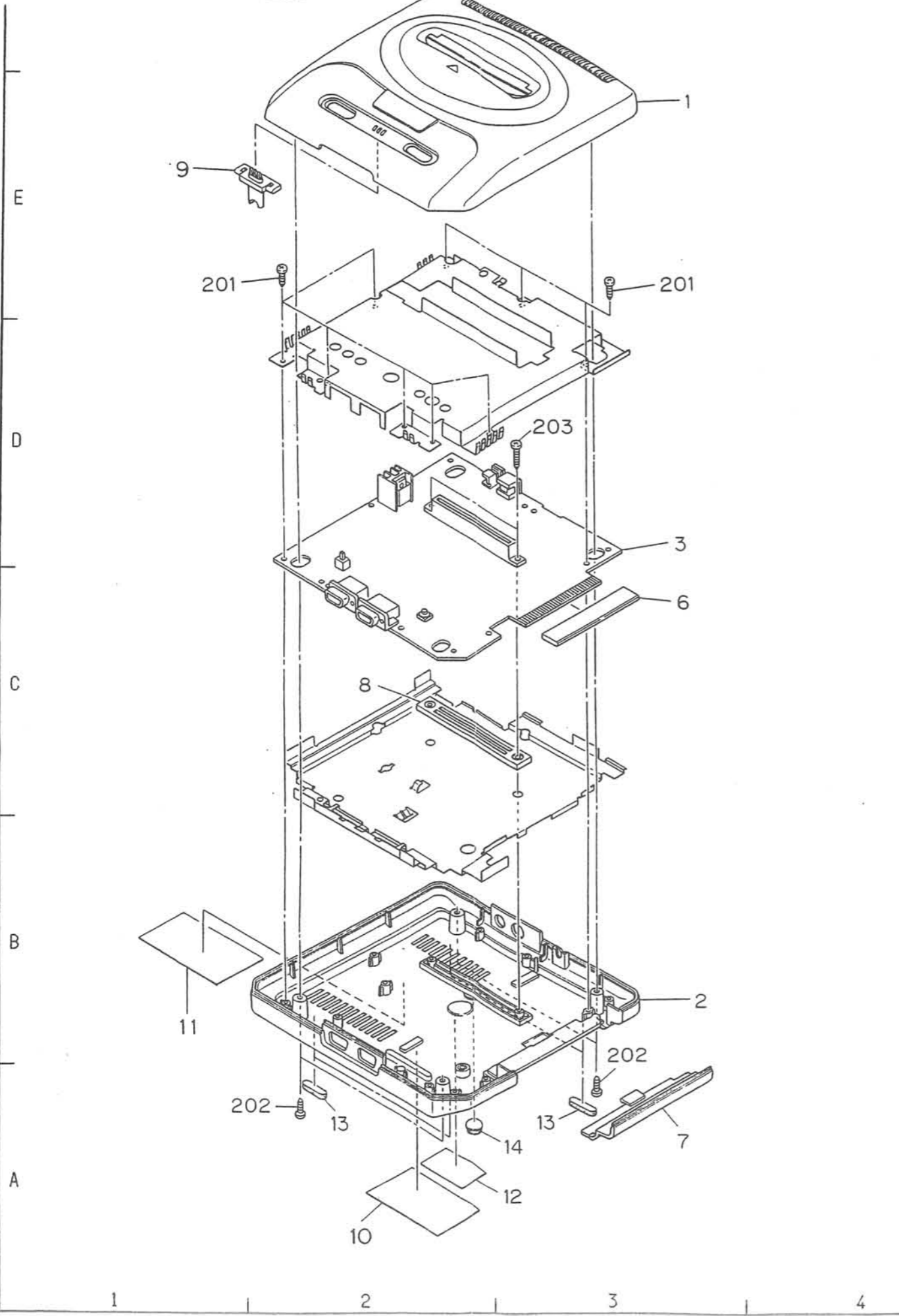

8-2. MECHANICAL PARTS LIST

Notes: NTSC → GENESIS II
PAL, RGB → MEGA DRIVE II

Ref. No.	Parts No.	Description	Q'TY	Remarks
1	610-5479	ASSY TOP CASE GENESIS2 USA	1	NTSC
1	610-5480	ASSY TOP CASE MD2 EUR	1	PAL,RGB
2	253-6592	BOTTOM CASE MD2 EXPORT	1	
3	837-9602-S	IC BD MD2 VA0S USA (CBA)	1	NTSC-S
3	837-9602-F	IC BD MD2 VA0F USA (CBA)	1	NTSC-F
3	837-9602-SM	IC BD MD2 VA0SM USA (CBA)	1	NTSC-SM
3	837-9603	IC BD MD2 VA0 EUR (CBA)	1	PAL,RGB
6	253-6298	60P CARD EDGE COVER	1	
7	253-6504	LID MD2	1	
8	253-6599	64P COVER MD2 EXPORT	1	
9	253-6598	LED LENS MD2 EXPORT	1	
10	670-0248	SEAL CUSTOMER SERVICE	1	NTSC
11	670-3128	LABEL FCC & SMITH MK-1630 USA	1	NTSC
12	670-3129	LABEL SER. NO. MK-1630 USA	1	NTSC
12	670-3130	LABEL SER. NO. MD2 MULTI	1	PAL,RGB
13	601-6973	RUBBER FOOT MD2	4	
14	601-6974	RUBBER FOOT SJ-5012 BLACK	1	
201	012-P00308	TAP SCR PH 3 × 8	9	
202	012-P00310	TAP SCR PH 3 × 10	4	
203	012-P00316-0B	TAP SCR PH BLK 3 × 16	2	