

EPSON

GPS Sports Monitor

WristableGPS

SF-710 | SF-510 | SF-310

User's Guide

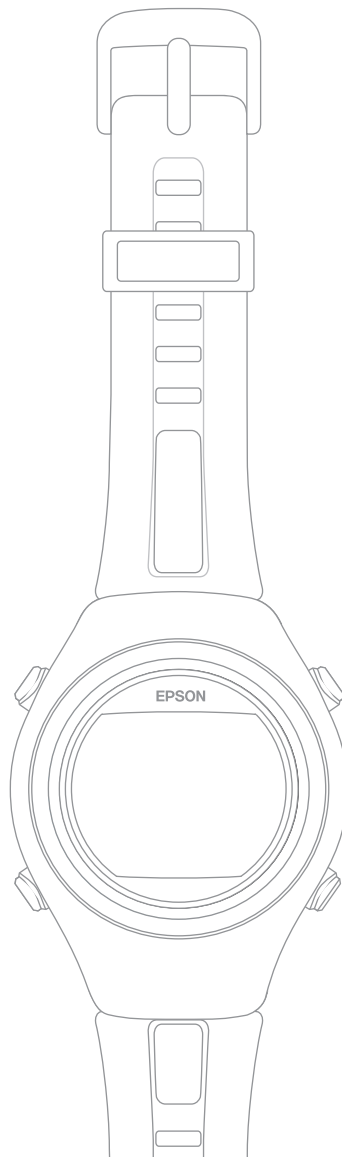
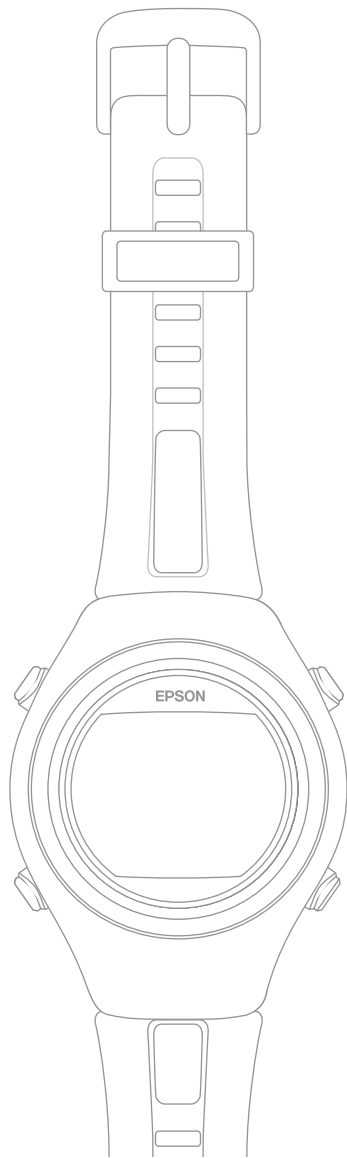

Introduction

Introduction

Thank you very much for purchasing this GPS Sports Monitor "WristableGPS".



To use the device correctly, make sure you read the supplied Quick Guide along with this User's Guide.

Keep the supplied Quick Guide handy to help you resolve any problems.

The illustrations and screens shown in the Quick Guide/User's Guide are for the SF-710.

By using a built-in GPS sensor and stride sensor, this device can measure running distance, pace elapsed time, altitude, and calories burnt. You can also upload recorded data to a dedicated Web site allowing you to look back over previous workouts. You can then make more effective plans and gain more enjoyment from your running.

Descriptions in the User's Guide

 Important:	Indicates things you must do. Ignoring these instructions or mishandling this device could cause the device to malfunction or operational problems to occur.
Note:	Indicates additional information and related information.
Menu Name	Indicates menu items displayed on the screen of the device.
A/B/C/D	Indicates the device buttons.
	Indicates related pages. If the related page is displayed in blue text, click it to display the related page.

Trademarks

EPSON and EXCEED YOUR VISION are registered trademarks of the Seiko Epson Corporation.

Microsoft and Windows are registered trademarks of the Microsoft Corporation in the United States of America and other countries.

The Bluetooth word mark and logos are the registered trademarks owned by Bluetooth SIG, Inc. and any use of such marks by the Seiko Epson Corporation is under license.

Other product names are the trademarks or registered trademarks of their respective companies.

Caution:

- Unapproved copying of part or all of this guide is strictly forbidden.
- The content of this guide may be changed without prior notice.
- Although every effort has been made to ensure the accuracy of this guide, contact us if you have any questions or notice any errors in descriptions in the content of this guide.
- Despite the preceding clause, we cannot accept any responsibility for mishandling due to errors in this guide.
- We cannot accept any responsibility for malfunctions and so that occur due to ignoring the content of this guide, the device being handled inappropriately, repairs or modifications performed by a third party that is not our company or appointed by our company.

Introduction

Features

Chronograph function



This function allows you to measure running data such as distance and time.

You can measure split and lap times, as well as using the GPS signal to measure distance and pace.

 [“Measuring Time, Distance, and Speed \(Chronograph Function\)” on page 39](#)

Split Time: Elapsed time from the start

Lap time: Time for each lap

You can use the history screen to check recorded measurement data.

 [“Checking Measurement Data” on page 64](#)

Interval function

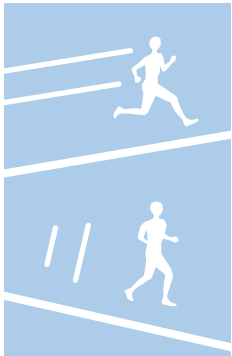

This function allows you to perform interval training.

Interval training:

Allows you to repeat sets of light and hard exercise to increase your athletic ability. An exercise menu is created using combinations of hard (sprint) and light (rest) exercise. An alarm sounds when it is time to change between sprinting and resting.

 [“Setting a Time and Distance for Hard and Light Workouts\(Interval Function\)” on page 44](#)

Goal function (timed race)



Allows you to set a time as your goal and measure the time taken until that goal is reached.

You can exercise while checking the elapsed time. You can also calculate the estimated distance.

 [“Measure until the time or distance set in advance is reached \(Goal function\)” on page 52](#)

You can use the history screen to check recorded measurement data.

 [“Checking Measurement Data” on page 64](#)

Introduction

Goal function (distance race)



Allows you to set a distance as your goal and measure the time taken until that goal is reached.

You can exercise while checking the distance. You can also calculate the estimated time.

 [“Measure until the time or distance set in advance is reached \(Goal function\)” on page 52](#)







You can use the history screen to check recorded measurement data.

 [“Checking Measurement Data” on page 64](#)

Mes. Settings



Allows you to change the measurement settings.

- When a time or distance is set in advance, laps are recorded automatically (AT Lap function)
 [“Recording Laps Automatically \(AT Lap Function\)” on page 57](#)
- Automatically stops measuring when you stop running, and resumes when you continue running (AT Pause function)
 [“Automatically Start/Stop Measuring \(AT Pause Function\)” on page 59](#)
- Set and measure the target time for one kilometer (Target Pace function)
 [“Setting a Pace and Measuring \(Target Pace Function\)” on page 61](#)
- Monitoring heart rate with the HR Monitor (heart rate function)
 [“Measuring Heart Rate” on page 72](#)
- Change the items and layout of the measurement screen display (screen settings function)
 [“Screen” on page 97](#)
- Tap to load a set function (tap function)
 [“Tap” on page 21](#)

Introduction

Settings



Allows you to change the settings for the device.

- ❑ Communicate with external devices (communication function)
[☞ "Comm. Settings" on page 94](#)
- ❑ Invert the screen's monochrome display (invert function)
[☞ "Sys. Settings" on page 95](#)
- ❑ Adjust the screen's contrast (adjust contrast function)
[☞ "Sys. Settings" on page 95](#)
- ❑ Turn on the light automatically when the screen changes (Auto Light function)
[☞ "Sys. Settings" on page 95](#)
- ❑ Set an alarm (Alarm function)
[☞ "Sys. Settings" on page 95](#)
- ❑ Turn off operation tones (Operation Tones function)
[☞ "Sys. Settings" on page 95](#)
- ❑ Reset configuration information in the device's memory (Initialize function)
[☞ "Sys. Settings" on page 95](#)

Other features

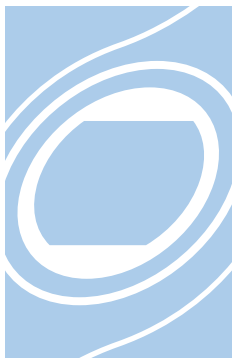

- ❑ Supports the Quasi-Zenith Satellite System (QZSS).
[☞ "Supports the Quasi-Zenith Satellite System" on page 32](#)
- ❑ You can measure pitch and stride using the built-in stride sensor (SF-710/SF-510 only).
[☞ "Educating Your Stride Sensor" on page 33](#)
- ❑ You can skip GPS positioning if it is taking too long.
[☞ "Skipping GPS positioning" on page 30](#)
- ❑ You can manage recorded data using the dedicated Web application "NeoRun".
[☞ "Data Management Using the Web Application \(NeoRun\)" on page 76](#)

Contents

Introduction

Features. 3

Using this Device Safely

Symbols in this Manual. 8

Notes on Usage. 9

 About the Device and Accessories. 9

 About the Cradle. 10

 Optional HR Monitor. 11

Notes on Storage. 11

Notes on Electromagnetic Waves. 11

Preparing and Basic Operations

Checking the Items Provided. 14

Basic Operations. 15

 Changing screens. 15

 Function of each button. 17

 Tap. 21

Charging. 22

 During Use. 22

 Charging. 23

Initializing. 26

 About the Battery. 28

Specifying a GPS (GPS Positioning). 29

 Measuring Function for the Device. 29

 GPS Positioning. 30

 Making Precise Measurements. 32

 Supports the Quasi-Zenith Satellite System. 32

Educating Your Stride Sensor. 33

 About the Stride Sensor. 33

 Educating the Stride Sensor. 33

Measurable items. 34

Measure

Measuring Time, Distance, and Speed
(Chronograph Function). 39

 What is the chronograph function?. 39

 Measuring. 40

 Screen Display. 42

Setting a Time and Distance for Hard and Light
Workouts(Interval Function). 44

 What is the Interval Function?. 44

 Setting Interval Conditions and Measuring. 45

 Loading Interval Conditions that have Already
 been Set. 49

 Screen Display. 51

Measure until the time or distance set in advance
is reached (Goal function). 52

 What is the goal function?. 52

 Setting the Time or Distance and Measuring
 53

 Screen Display. 56

Recording Laps Automatically (AT Lap
Function). 57

Automatically Start/Stop Measuring (AT Pause
Function). 59

Setting a Pace and Measuring (Target Pace
Function). 61

Checking Measurement Data (History Function)

Checking Measurement Data. 64

 Measurement Data that can be Checked in
 History. 64

Measuring Heart Rate (HR Monitor)

Preparing to Measure Heart Rate. 67

 Preparing the HR Monitor. 67

 Wearing the HR Monitor. 67

 Registering the HR Monitor to the Device. 68

 Enabling the HR Monitor. 70

Measuring Heart Rate. 72

 Checking the Communication Status with the
 HR Monitor. 72

 Displaying the Measured Heart Rate Screen. 72

Replacing the Battery for the HR Monitor. 74

Data Management Using the Web Application (NeoRun)

What is the Web Application (NeoRun). 77

Installing the NR Uploader. 79

Creating an Account (When Using for the First
Time). 80

Uploading Measurement Data. 82

Checking Uploaded Measurement Data. 84

Contents**Settings**

Making Settings.	88
Mes. Settings.	89
Changing the Mes. Settings.	89
Mes. Settings Table.	91
Settings.	93
Changing the Settings.	93
Settings Table.	94
Screen.	97
Screen Settings.	98
Screen Pattern Table.	99
Measurement Display Items Table.	101
Changing the Measurement Screen.	103
Changing the Lap.	108
Setting Examples.	110

Maintenance

Performing Maintenance.	112
Performing After Care.	112
About the strap.	112
HR Monitor Maintenance.	112
Replacing the Battery.	114
About the Device's Rechargeable Battery.	114
About the HR Monitor Battery.	114
Updating the Firmware.	115
Checking the Firmware Version.	115
Updating the Firmware.	115

Troubleshooting

Caution:.	117
Problem Solving.	118
Resetting the System.	121
Contacting us About this Product.	122
After Service.	123

Appendix

Understanding the Icons.	125
Product Specifications.	126
Device Specifications.	126
Cradle specifications.	127
Option Specifications.	127
Glossary.	129

Index

Using this Device Safely

Using this Device Safely

To use this device safely, make sure you read the user's guides before use (the supplied Quick Guide and this User's Guide).

If you do not follow the content of the user's guides, a problem or accident could occur.

- Keep the user's guides (supplied Quick Guide and User's Guide) handy to help you resolve any problems.
- This device is for use in Japan only.**
- This is not a medical device. Use for exercising only.

Symbols in this Manual

This User's Guide uses the following symbols to prevent injury to the user or to others, or damage to property when using this device, as well as preventing dangerous usage. Read the guide after understanding these symbols.



Ignoring these instructions or mishandling this device could cause serious injury or death.



Caution:

Ignoring these instructions or mishandling this device could cause injury or damage to property.



This symbol indicates operations (instructions and actions) you must perform.









This symbol indicates actions (forbidden actions) that must not be performed.

Using this Device Safely

Notes on Usage

About the Device and Accessories

 警告	
	Exercise according to your own physical condition. It is dangerous to exercise suddenly or excessively. If you feel nauseous or if your physical condition alters while exercising, stop exercising and contact a doctor.
	Do not watch the device too closely while exercising. Otherwise you could fall or cause a traffic accident. Pay close attention to your surroundings while using the device.
	Do not use while scuba diving.
	This device is made using precision parts and electronic components. Do not use or store in the following locations. Otherwise an electric shock, fire, problem, or malfunction could occur. <ul style="list-style-type: none"> <input type="checkbox"/> Locations subject to large changes in temperature and humidity <input type="checkbox"/> Near volatile substances <input type="checkbox"/> Sooty or dusty places <input type="checkbox"/> Near a fire <input type="checkbox"/> Locations close to magnetic fields (near speakers and so on)
	Do not disassemble or perform repairs yourself. Otherwise an electric shock or an accident could occur.
	Do not leave this device in reach of children.

 注意	
	If you suffer from any allergies or rashes when wearing the device, stop using it immediately and contact a medical specialist such as a dermatologist.
	The device is water resistant at 5 barometric pressures. Although you can use the device in water, such as when swimming, do not perform button operations when it is wet. This may effect the quality of the waterproofing.
	Do not hold the device directly under high pressure water from a faucet. Water pressure from a faucet is high and could effect the quality of the waterproofing.
	Do not use in the bath or in a sauna. Steam and materials in soap and in hot springs could effect the quality of the waterproofing or cause rust.

Using this Device Safely

About the Cradle

Do not use the cradle if it is damaged. Otherwise a problem or fire could occur. If it is damaged, contact a repair center.

Do not use them if you notice any abnormalities such as smoke, strange odors, or noises. Otherwise a fire could occur.

If any abnormalities occur, disconnect the cable from the cradle immediately, and contact a repair center.



Do not use if any foreign substances or liquids such as water get inside any of the devices. Otherwise an electric shock or fire could occur. Disconnect the cable from the cradle immediately, and contact a repair center.

Do not use the cable for the cradle if any foreign substances such as dust are stuck to the connector. Otherwise a fire could occur.

Do not use the cradle to charge any other devices. Also, do not charge the device with any thing except for the cradle. Otherwise a problem, electric shock, or fire could occur.

Using this Device Safely

Optional HR Monitor

⚠ 警告	
	If the HR monitor battery is accidentally swallowed, contact your doctor immediately.
	Be careful not to injure yourself when replacing the HR monitor battery.
	When disposing of the HR monitor battery, follow your local laws and regulations.
	When replacing the HR monitor battery, only use the type of battery specified. Also, make sure the polarities (+ and -) are correct.
	Do not place the battery or the HR monitor with a battery installed into a fire.

Notes on Storage

⚠ 注意	
	Do not place in a location subject to magnetic fields or electromagnetic waves, such as on top of a television. Otherwise, data may be corrupted or lost.
	Do not leave the device unattended in locations where it could come into contact with chemicals, or in locations where chemical substances are emitted. If any spray-on liquid such as gasoline, nail varnish, or cosmetics, as well as cleaning liquid, toilet detergent, adhesives, and so on, come into contact with the device or the strap, they could cause discoloring or damage.

Notes on Electromagnetic Waves

This device is equipped with Bluetooth® Smart technology. When operating supported HR monitors and smartphones, this function wirelessly sends and receives heart rate measurement data to the device.

This device has been classified as a small electronic data communication system based on Radio Law. Therefore, this device does not require a radio station license. The following acts may be punishable by law.

- Disassembling or remodeling the device
- Removing the verification or certification number for the device

VCCI Class B Information Technology Device

This device is a class B information technology device. This device is designed for home use, but interference could occur when using in close proximity to radios or television antennas.



Using this Device Safely

Certification information

Japan



R007-AB0210
T D13-0316001



Frequency

This device uses the frequency bands 2.402 to 2.480 GHz. Wireless devices may use the same frequency. Note the following points to avoid wireless interference with other wireless devices.

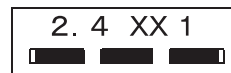

Precautions when performing wireless communication

This device operates on the 2.4 GHz band.

This device operates in the same frequency bandwidth as industrial, scientific, and medical devices such as microwave ovens and mobile object identification (RF-ID) systems (licensed premises radio stations, amateur, and unlicensed specified low-power radio stations (hereafter "other radio stations")) used in factory production lines.

1. Before using this device, make sure there are no "other radio stations" being used in the vicinity.
2. If this device causes RF interference between the device and "other radio stations", promptly move to a different location, stop using the device, and contact your local dealer to ask for advice on preventing interference (for example setting up partitions).
3. In addition, when harmful radio wave interference occurs between the device and "other radio stations", and refer to "Contacting us about this product" to contact our information center.

["Contacting us About this Product" on page 122](#)

警告	
	If you notice any abnormalities on your skin and so on, stop using the device immediately and contact a specialist.
	In areas in which usage is restricted, such as on airplanes and in hospitals, follow the rules and regulations provided (such as in-flight announcements).
	Do not use the device if you have a surgically implanted pacemaker.
	Do not bring the device into an operating room, intensive care unit, and so on, and do not use the device near medical equipment. Radio waves from the device may interfere with electronic medical equipment causing the equipment to malfunction and cause an accident.

Preparing and Basic Operations

You need to make the following preparations before use.

 **"Checking the Items Provided" on page 14**

 **"Basic Operations" on page 15**

 **"Charging" on page 22**

 **"Initializing" on page 26**

Once preparations are complete, check the method and important points when performing GPS satellite positioning.

 **"Specifying a GPS (GPS Positioning)" on page 29**



 **"Educating Your Stride Sensor" on page 33**

 **"Measurable items" on page 34**

Preparing and Basic Operations

Checking the Items Provided

Make sure you check that all of the following items have been supplied with this product. If there is anything missing, contact your local dealer.

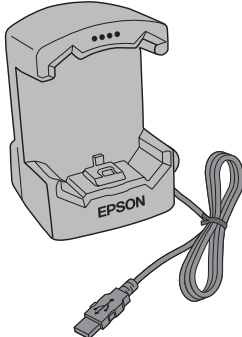
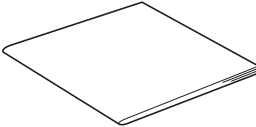
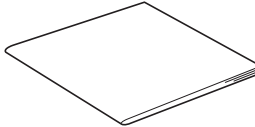
This device (One of the models that you purchased.)		
<p>SF-710</p> 	<p>SF-510</p> 	<p>SF-310</p> 
Cradle	Quick Guide	Warranty
		

Options

The following products are available as optional extras. Contact your local dealer for more information.

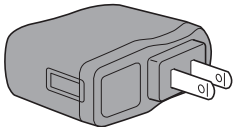
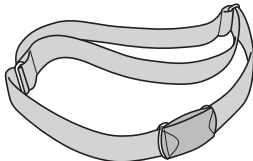
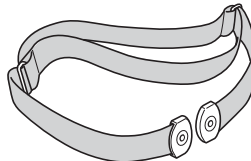
AC Adapter (Model No.: SFAC01)	HR Monitor (Model No.: SFHRM01)	HR Belt (Model No.: SSHRST01)
		

Basic Operations

Changing screens

This device is comprised of a Time screen, Measurement screen, Settings screen (**Settings** menu and **Mes. Settings** menu), and History screen, and you can perform operations with the following buttons.



⇨ : Short press

➡ : Long press (for at least two seconds)

Preparing and Basic Operations

Settings menu

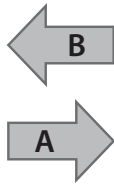
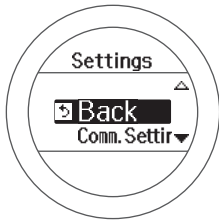

☞ “Setting screen (Settings menu/Mes. Settings menu)” on page 19

Time screen

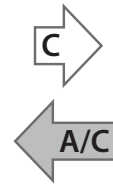

☞ “Time screen” on page 17

Measurement screen



☞ “Measurement screen” on page 18

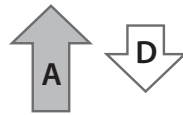

History screen

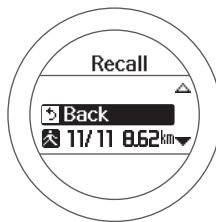

☞ “History screen” on page 20

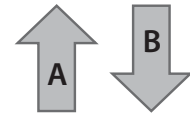

Mes. Settings menu

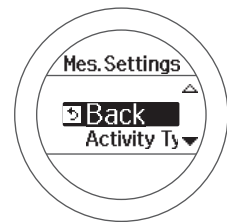

☞ “Setting screen (Settings menu/Mes. Settings menu)” on page 19

See the following pages for information on making settings for each screen.

☞ “Making Settings” on page 88

Note:

- ☐ When you are resting, the device enters sleep status and the time is displayed. This does not indicate a problem as the display is restored the next time you move. You can also turn off the sleep function.

☞ “Sys. Settings” on page 95

- ☐ The time screen is displayed if no operations are made for a specified length of time. The time varies depending on the screen displayed.

Sys. Settings/User Settings/History Screen: 3 mins.

Measurement Screen (without measurements being made): 60 mins.

- ☐ When three minutes have passed without any operations being performed on the **Mes. Settings** menu screen, the measurement screen is displayed.

Preparing and Basic Operations

Function of each button

The function for each button changes depending on which screen is displayed.

Time screen

Operation buttons



Button Operation		Explanation
A	Short press	-
	Long press (for at least two seconds)	Turns the power on or off.
B	Short press	Turns the light on or off. The light turns on for approximately 10 seconds.
	Long press (for at least two seconds)	Displays the Settings menu. ☞ "Setting screen (Settings menu/ Mes. Settings menu)" on page 19
C	Short press	Performs GPS positioning, and displays the measurement screen. ☞ "Measurement screen" on page 18
	Long press (for at least two seconds)	Changes to indoor mode (GPS off) (SF-710/SF-510 only). ☞ "Indoor mode (SF-710/SF-510 only)" on page 31
D	Short press	Displays a record of the measurement history (history screen). ☞ "History screen" on page 20
	Long press (for at least two seconds)	Performs Bluetooth® communication. Use this when uploading measurement data.

Preparing and Basic Operations

Measurement screen

Operation buttons



Button Operation		Explanation
A	Short press	There are four measurement screens that can be displayed. This changes the screen.
	Long press (for at least two seconds)	Displays the time screen. Not available while measuring.
B	Short press	Turns the light on or off. The light turns on for approximately 10 seconds.
	Long press (for at least two seconds)	Displays the Mes. Settings menu. Not available while measuring.
C	Short press	Starts, stops, or restarts measuring.
	Long press (for at least two seconds)	Displays the time screen. The time screen is displayed if you use reset* while measuring is stopped. Not available while measuring.
D	Short press	Records laps while measuring.
	Long press (for at least two seconds)	Resets* while measuring is stopped. Not available while resetting measurements.

* When you reset the display, it returns to the status before measuring started allowing you to start the next measurement. Data that has been measured up to that point is stored in the device's memory.

Preparing and Basic Operations

Setting screen (Settings menu/Mes. Settings menu)

Operation buttons

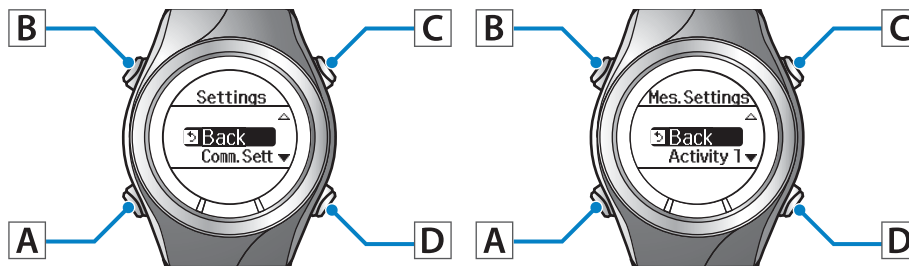

Button Operation		Explanation
A	Short press	Confirm a selection.
	Long press (for at least two seconds)	From the Settings menu, the time screen is displayed. From the Mes. Settings menu, the measurement screen is displayed.
B	Short press	Turns the light on or off. The light turns on for approximately 10 seconds.
	Long press (for at least two seconds)	-
C	Short press	Selects the top item. Increases the value.
	Long press (for at least two seconds)	Selects the top item. Speeds through the values.
D	Short press	Selects the bottom item. Decreases the value.
	Long press (for at least two seconds)	Selects the bottom item. Speeds through the values.

Preparing and Basic Operations

History screen

Operation buttons



Button Operation		Explanation
A	Short press	Confirm a selection.
	Long press (for at least two seconds)	Displays the time screen.
B	Short press	Turns the light on or off. The light turns on for approximately 10 seconds.
	Long press (for at least two seconds)	-
C	Short press	Selects the top item.
	Long press (for at least two seconds)	Selects the top item.
D	Short press	Selects the bottom item.
	Long press (for at least two seconds)	Selects the bottom item.

Preparing and Basic Operations

Tap

You can perform one of the following operations by tapping the screen once while measuring.

Tapping is not supported while measuring in SF-710/SF-510.

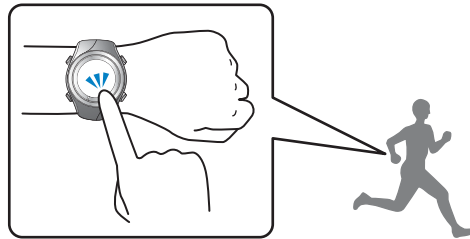

Function	Explanation
Lap	Records the lap. The same operation as pressing D while measuring.
Light	Turns on the light. The light turns on for approximately 10 seconds. The same operation as pressing B .
Screen Chg.	Changes between the four measurement screens. The same operation as pressing A .
OFF (default)	Turns off tap operations.

Note:

- ❑ When you want to change functions by tapping, set **Tap** from the **Mes. Settings** menu.
🔗 “Mes. Settings” on page 89
- ❑ The operation may not be recognized if you tap the screen rapidly in succession. Leave a gap of approximately one second between taps.
- ❑ When bike mode is selected, the tap function may operate automatically depending on the condition of the road surface. If this occurs, we recommend setting **OFF**.

Preparing and Basic Operations

Charging

During Use

! Important:

- ❑ Do not place the device in the cradle if it is wet from water or sweat. Otherwise the contact points on the cradle and the device could corrode, malfunction, or cause a communication failure.

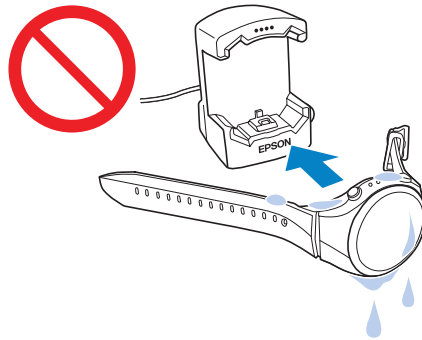

- ❑ Do not perform button operations when it is wet. Otherwise a malfunction could occur.

If the device is wet from water or sweat, use a little clean water to wash the contact points, wipe away most of the water with a towel and so on, and then let it dry naturally before placing it in the cradle.

Contact points

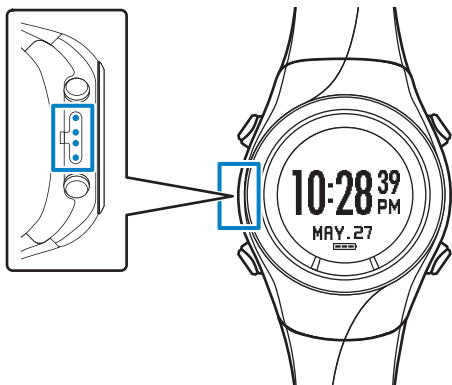

Use low pressure water to wash the device.



See the following for more details about daily maintenance.

 [“Performing Maintenance” on page 112](#)

Preparing and Basic Operations

Charging

! **Important:**

- ❑ **Charge this device when using it for the first time.**
- ❑ **Charge in an environment where the surrounding temperature is 5 to 35°C. In any other environment the following charge error screen is displayed, and charging stops. When it returns to a suitable temperature, charging continues.**

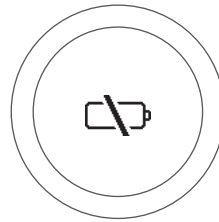

1 Connect the cradle using one of the following methods.

■ **Using a computer**

Connect the cradle's USB plug to the computer's USB port.

This is not guaranteed to work with all computers. Also, USB hubs are not supported. Connect the cradle directly to the computer.

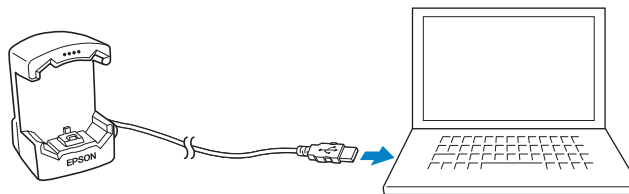

■ **Using the AC adapter**

Connect the cradle's USB plug to the AC adapter's USB port.

We recommend using the optional AC adapter (Model No.: SFAC01). If you do not use a supported AC adapter, you may not be able to charge or it may not operate correctly.

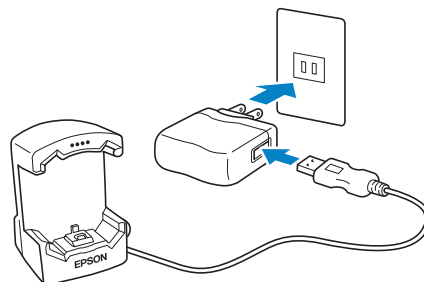

2 Place the device into the cradle.

Check that the contact points on the device are pointing up and match the contact marks on the cradle, and then press straight down until it is fixed in place.

Preparing and Basic Operations

After placing the bottom of the device into the cradle, push carefully on the top of the device.

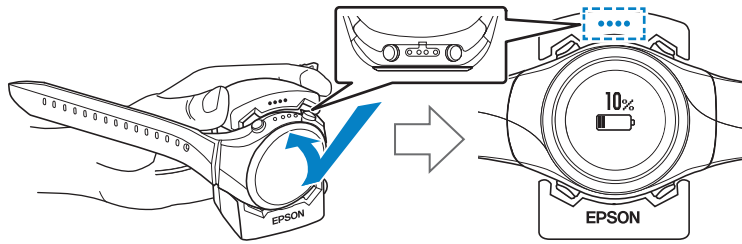

Important:

Make sure the device is placed in the correct direction. Otherwise the cradle could be damaged.

When the device is placed in the correct direction, the alarm sounds, the following screen is displayed, and charging starts.

Although the average time necessary for a full charge is **2.5 to 3.5 hours**, this varies depending on the situation.

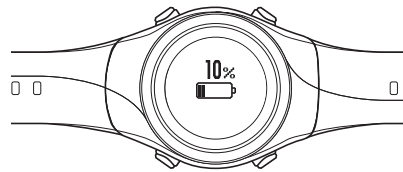

3

Check that charging is complete.

When the following charging icon turns on, charging is complete.

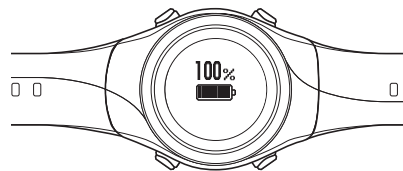

Note:

When the battery icon displays 100%, an over-charge function is activated to prevent the battery from being over charged. The device will not be damaged even if you continue to charge the battery.

Preparing and Basic Operations

4 When charging is complete, remove the device from the cradle.

Hold the cradle in one hand and press the device down into the lower part of the cradle with your other hand for a smooth release.

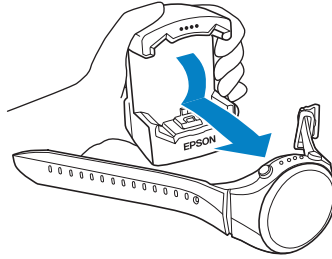

Preparing and Basic Operations

Initializing

After charging the device for the first time and removing it from the cradle, follow the on-screen instructions to initialize.



Important:

Set the time by receiving a GPS signal. Signals from the GPS cannot be received while indoors. Make sure this is performed outside.

Operation buttons



1 Set the language.

Use C/D to select, and then press A.

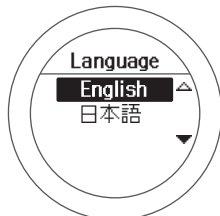

2 Set the Units.

Use C/D to select, and then press A.

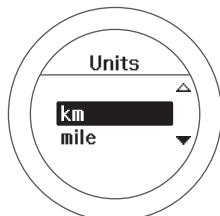

3 Set your Height and Weight.

Use C/D to select, and then press A.

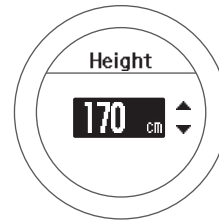

4 Set your DOB.

Use C/D to select, and then press A.

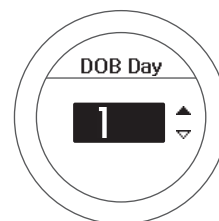
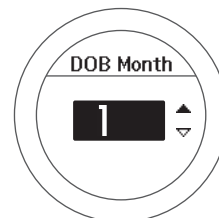
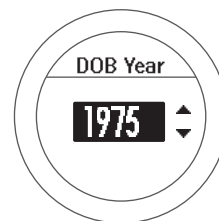

5 Set your Gender.

Use C/D to select, and then press A.

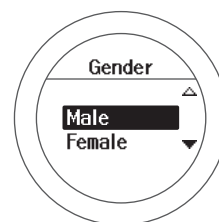

Preparing and Basic Operations

- 6 Set today's date.
Use C/D to select, and then press A.

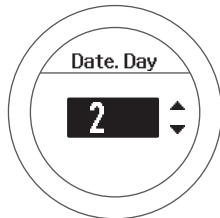
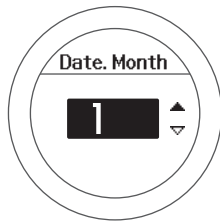

- 7 Set the Date Format.
Use C/D to select, and then press A.

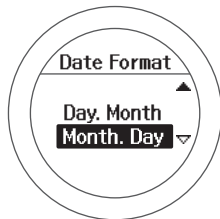

- 8 Go to a location outside with no obstructions overhead.



Important:

Next time, a signal is received from the GPS and time is automatically synchronized. Since the signal from the GPS cannot be received inside, go outside to a location without any obstructions overhead.

- 9 This completes the settings.
Use C/D to highlight Yes, and then press A.

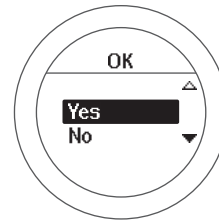

A signal is received from the GPS and time is automatically synchronized.

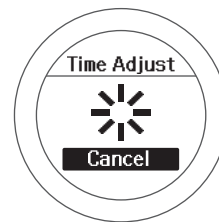

When Complete is displayed, press A.

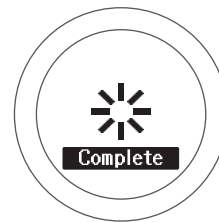

The time screen is displayed.



Note:

- ❑ When you are resting, the device enters sleep status and the time is displayed. This does not indicate a problem as the display is restored the next time you move.
- ❑ If time synchronization fails, the signal from the GPS may be being obstructed. Perform **Time Adjust** from **Sys. Settings**.

 "Sys. Settings" on page 95

Preparing and Basic Operations

About the Battery

You can check how much charge remains from the battery icon below the time display.



Battery icon					
Hours remaining*	GPS On HR Monitor Off	30 to 21 hours	21 to 12 hours	12 to 3 hours	3 to 0 hours
	GPS On HR Monitor On	26 to 18 hours	18 to 10 hours	10 to 2 hours	2 to 0 hours

* Standard hours during which you can use the Chronograph function while receiving a GPS signal. Usage hours vary depending on the conditions (HR Monitor On, frequency the light turns on, and so on).



Important:

Nothing is displayed when the battery runs out. If the device is left for a long time with a flat battery, the performance of the rechargeable battery will deteriorate. Make sure you charge the device **once every six months** even when it is not being used.

Note:

Even if the battery runs out, measurement data is stored in the main memory.

Specifying a GPS (GPS Positioning)

Measuring Function for the Device

This device receives a signal from the GPS, and measures distance and pace. To make sure measurements are performed accurately, try to use the device under the following conditions which allow for easy reception of GPS signals.

- Outside with no obstructions overhead
- Wear the device with the screen facing up

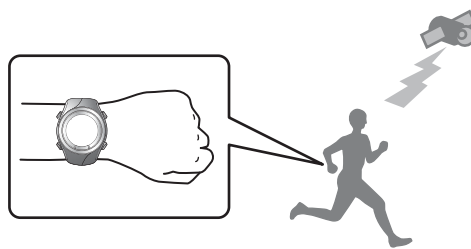

You cannot receive a signal from the GPS when inside and in the following environments.

Locations where you cannot receive signals

<p>Inside rooms or buildings, or underground</p>	<p>In tunnels</p>	<p>Under water</p>

Locations that are difficult to receive signals

<p>Locations with high levels of electronic interference, such as constructions sites and heavy traffic</p>	<p>Near high-voltage wires or television towers, overhead electric wires for trains, roads with skyscrapers</p>	<p>On water</p>

Preparing and Basic Operations

GPS Positioning

When you change to the measurement screen, the device receives a signal from various satellites, and identifies a GPS to use for measurement.



Important:

While identifying a GPS, make sure you are outside with no obstructions overhead, and try to keep the device as still as possible.

Operation buttons



- 1 Go to a location outside with no obstructions overhead.
- 2 Perform GPS positioning.
Press C.
GPS positioning starts.

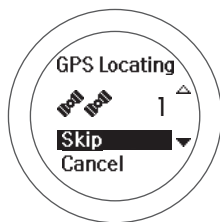

When GPS positioning is complete, the positioning complete screen flashes, and then the measurement screen is displayed.

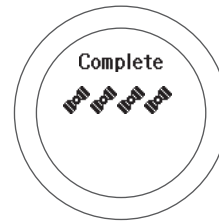

Note:

It usually takes less than two minutes to complete GPS positioning.

If GPS positioning is not complete after two minutes or **Failed** is displayed, we recommend selecting **Cancel**, moving to a different location, and trying again.

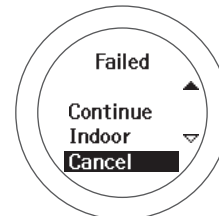

When the measurement screen is displayed, you can start measuring.

[“Measure” on page 38](#)

Skipping GPS positioning

If you want to start measuring immediately, or if GPS positioning is taking too long, select **Skip** during GPS positioning and start measuring.

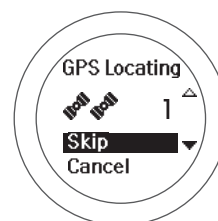

Preparing and Basic Operations

GPS positioning continues while measuring, and when positioning is complete the device starts recording positional information. The route before GPS positioning is complete is not recorded.

Indoor mode (SF-710/SF-510 only)

This function allows you to measure without performing GPS positioning. Use this when GPS positioning cannot be performed because you are inside and so on.

The route and so on is not recorded in indoor mode. Also, measurement items are limited in indoor mode.
[☞ “Measurable items” on page 34](#)

Use either of the following methods to enter indoor mode.

- Press **C** on the time screen
- If GPS positioning fails, select **Indoor** on the screen displayed



Preparing and Basic Operations

Making Precise Measurements

In the following situations, complete GPS positioning, and then display the measurement screen while you are outside for at least 15 minutes with no obstructions overhead. This allows you to make precise measurements.

- The first time you use the device after purchase
- When the device has not been used for several months

You do not need to make these preparations from the second time.

Note:

The basic configuration of the GPS system is 24 satellites orbiting the Earth at an altitude of 20,000 km, with at least four satellites traveling in six different orbits. The GPS receiver acquires data from four satellites and calculates the latitude, longitude, altitude, and time. Measuring can start once positioning has been performed and this information has been received. Since you can receive more detailed GPS navigation data (satellite orbital information) after 15 minutes from this point, you can make more precise measurements.

However, errors may occur in distance measurements, even after waiting 15 minutes or more, due to atmospheric conditions and the usage environment.

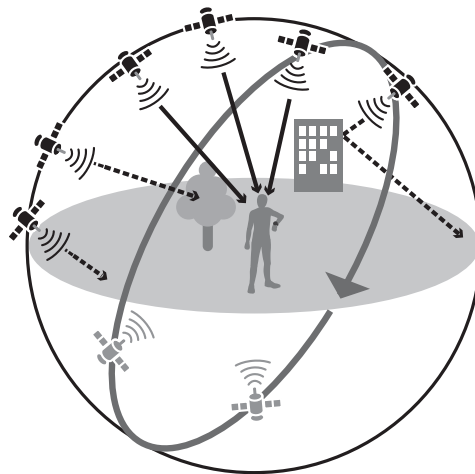

Supports the Quasi-Zenith Satellite System

This device supports the Quasi-Zenith Satellite System (QZSS). The Quasi-Zenith Satellite System is a system of satellites that pass directly over Japan allowing signals to be sent to areas of Japan that were previously trouble spots, such as mountainous regions, or areas with a high density of skyscrapers such as the center of Tokyo.

Educating Your Stride Sensor

About the Stride Sensor

This device contains a stride sensor that uses a stride algorithm to learn your pace from your actual speed and your body's vibration frequency. This allows the device to calculate distance and laps with high precision, as well as measure your pitch and stride even in locations that cannot receive signals from GPS satellites (SF-710/SF-510 only).

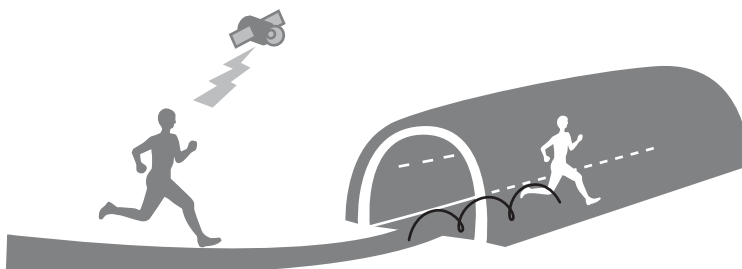

Educating the Stride Sensor

When using the device for the first time, run under the following conditions so that the stride sensor can learn your stride.

Location/Time

Run or walk in the following locations that allow GPS positioning.

- When outside with no obstructions overhead: Approximately 10 mins.
- When surrounded by tall buildings: approximately 30 mins.

Measure

Measure using the chronograph function.

 [“Measuring Time, Distance, and Speed \(Chronograph Function\)” on page 39](#)

Note:

- You do not need to make these preparations from the second time. However, note that information on your stride is initialized if the device is initialized.
- When you mainly use the device for walking, from the **Mes. Settings** menu, set **Activity Type** to **Walk**.
 [“Mes. Settings” on page 89](#)
- The device's stride sensor is used for running and walking. This does not support bicycle mode. In bike mode, "-" is displayed for the stride and pitch on the measurement display.
- Large measurement errors may occur if your stride differs significantly from this learning session.

Preparing and Basic Operations

Measurable items

Items that can be measured by each measurement function for chronograph, interval, and goal change according to the settings for the GPS signal (GPS on/off) and the HR monitor.

When GPS is off for indoor mode (SF-710/SF510 only), the route is not recorded.

○: Measurable -: Unmeasurable

Preparing and Basic Operations

		SF-710	SF-510	SF-310
Measurement item (display name)	Distance (Dist.)	<input type="radio"/>	<input type="radio"/>	<input type="radio"/>
	Lap Distance (LapDist.)	<input type="radio"/>	<input type="radio"/>	<input type="radio"/>
	Pace (Pace)	<input type="radio"/>	<input type="radio"/>	<input type="radio"/>
	Average Pace (Av.Pace)	<input type="radio"/>	<input type="radio"/>	<input type="radio"/>
	Lap Pace (LapSpd)	<input type="radio"/>	<input type="radio"/>	<input type="radio"/>
	Speed (Speed)	<input type="radio"/>	<input type="radio"/>	<input type="radio"/>
	Average Speed (Av.Spd)	<input type="radio"/>	<input type="radio"/>	<input type="radio"/>
	Lap Speed (LapSpeed)	<input type="radio"/>	<input type="radio"/>	<input type="radio"/>
	Split Time (Split)	<input type="radio"/>	<input type="radio"/>	<input type="radio"/>
	Lap Time (Lap)	<input type="radio"/>	<input type="radio"/>	<input type="radio"/>
	Time (Time)	<input type="radio"/>	<input type="radio"/>	<input type="radio"/>
	Calories Burnt (Calories)	<input type="radio"/>	<input type="radio"/>	<input type="radio"/>
	Altitude (Alt.)*	<input type="radio"/>	<input type="radio"/>	<input type="radio"/>
	Guide Time (Guide)	<input type="radio"/>	<input type="radio"/>	<input type="radio"/>
	Guide Distance (GuideDist.)	<input type="radio"/>	<input type="radio"/>	<input type="radio"/>
	Stride (Stride)	<input type="radio"/>	<input type="radio"/>	-
	Average Stride (Av.Stride)	<input type="radio"/>	<input type="radio"/>	-
	Lap Stride (LapStride)	<input type="radio"/>	<input type="radio"/>	-

Preparing and Basic Operations

		SF-710	SF-510	SF-310
Measurement items (display name)	Pitch (Pitch)	<input type="radio"/>	<input type="radio"/>	-
	Average Pitch (Av.Pitch)	<input type="radio"/>	<input type="radio"/>	-
	Lap Pitch (LapPitch)	<input type="radio"/>	<input type="radio"/>	-
	HR (HR)	See the following table for items that can be measured by the HR monitor settings		
	Average HR (Av.HR)			
	Maximum HR (Max.HR)			
	Lap HR (LapHR)			
	Steps (Steps)	<input type="radio"/>	<input type="radio"/>	-
	Lap Steps (LapStp)	<input type="radio"/>	<input type="radio"/>	-
	HR Zone Time (SpentHR)	See the following table for items that can be measured by the HR monitor settings		
	Time to HR Zone (TimeHR)			
	Total Ascent (Tot.Asc.)*	<input type="radio"/>	-	-
	Total Descent (Tot.Des.)*	<input type="radio"/>	-	-
	Grade (Grade)*	<input type="radio"/>	-	-
	Latitude/Longitude (LAT/LONG)	<input type="radio"/>	<input type="radio"/>	-
	Estimated Time (Est.)	<input type="radio"/>	<input type="radio"/>	<input type="radio"/>
	Estimated Distance (Est.Dist.)	<input type="radio"/>	<input type="radio"/>	<input type="radio"/>

* Not measured during indoor mode.  "Indoor mode (SF-710/SF-510 only)" on page 31

Preparing and Basic Operations

See the following table for items that can be measured by the HR monitor settings

		SF-710		SF-510		SF-310	
HR monitor status		On	Off	On	Off	On	Off
Measurement items (display name)	HR (HR)	<input type="radio"/>	-	<input type="radio"/>	-	<input type="radio"/>	-
	Lap HR (LapHR)	<input type="radio"/>	-	<input type="radio"/>	-	<input type="radio"/>	-
	Average HR (Av.HR)	<input type="radio"/>	-	<input type="radio"/>	-	<input type="radio"/>	-
	Maximum HR (Max.HR)	<input type="radio"/>	-	<input type="radio"/>	-	-	-
	Time to HR Zone (Spent.HR)	<input type="radio"/>	-	<input type="radio"/>	-	-	-
	HR Zone Time (Time.HR)	<input type="radio"/>	-	<input type="radio"/>	-	-	-







The HR monitor can be purchased as an optional item.

Measure

Measure

Using the positional information and time for the GPS signal, the time, distance, and speed are measured automatically.

Also, training is supported for a variety of functions, such as the interval function.

-  ["Measuring Time, Distance, and Speed \(Chronograph Function\)" on page 39](#)
-  ["Setting a Time and Distance for Hard and Light Workouts\(Interval Function\)" on page 44](#)
-  ["Measure until the time or distance set in advance is reached \(Goal function\)" on page 52](#)
-  ["Recording Laps Automatically \(AT Lap Function\)" on page 57](#)
-  ["Automatically Start/Stop Measuring \(AT Pause Function\)" on page 59](#)
-  ["Setting a Pace and Measuring \(Target Pace Function\)" on page 61](#)

Measuring Time, Distance, and Speed (Chronograph Function)

What is the chronograph function?

This function allows you to measure split times and lap times simultaneously. Also, since this device is equipped with a GPS function, you can automatically measure time, distance, and speed using the positional information and time from the GPS signal.

This is useful for a variety of activities such as running or walking, and can be used for competition or standard exercise.

Split Time

Measures the elapsed time from the start.

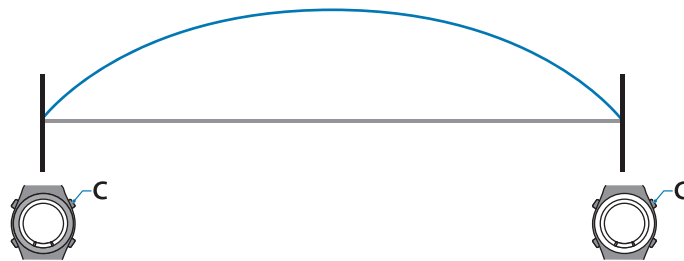

Press **C** to start measuring, and press **C** again to stop measuring.

Lap Time

Records the elapsed time for each lap.

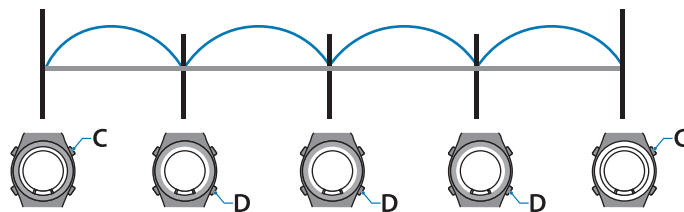

Press **D** while measuring to record a lap.

Also, when using the AT Lap function, laps are recorded automatically when a time or distance is set in advance.

[🔗 “Recording Laps Automatically \(AT Lap Function\)” on page 57](#)

Measure

Measuring

! Important:

- When performing GPS positioning, make sure the screen is facing up and you are outside with no obstructions overhead.

[“Specifying a GPS \(GPS Positioning\)” on page 29](#)

- It usually takes less than two minutes to complete GPS positioning.

If GPS positioning is not complete after two minutes or **Failed** is displayed, we recommend selecting **Cancel**, moving to a different location, and trying again.

Operation buttons

**1** Display the measurement screen.

Press **C** on the time screen.

GPS positioning starts, and the measurement screen is displayed once positioning is complete.

**2** Start measuring.

Press **C**.

**3** Record the lap.

Press **D** while measuring.

The Lap Hold Screen* is displayed for 10 seconds, and then the measurement screen is displayed.

[“Lap Hold Screen” on page 43](#)



* The screen display differs depending on the settings.

[“Screen Pattern Table” on page 99](#)

Note:

- You can skip GPS positioning if you want to start measuring immediately or if it is taking too long.

[“Skipping GPS positioning” on page 30](#)

- Use indoor mode when GPS positioning cannot be performed because you are inside and so on.

[“Indoor mode \(SF-710/SF-510 only\)” on page 31](#)

- Screens are explained using the default screens. You can invert the screen's monochrome display.

[“Sys. Settings” on page 95](#)

Measure

4 Stop measuring.

Press **C** while measuring.



Press **C** to start measuring again.

5 Reset the measurement results.

Hold down **D** while measuring is stopped.

When you reset the display, it returns to the status before measuring started allowing you to start the next measurement.



Data measured up to that point is stored in the device's memory, and you can check it by pressing **D** on the time screen.

[🔗](#) ["Checking Measurement Data" on page 64](#)

Note:

- After resetting the measurement results, hold down **A** to display the time screen.
- If you hold down **C** while measuring is stopped, the measurement results are reset and the time screen is displayed.
- If no operations are made for 60 minutes, the time screen is displayed.

Measure

Screen Display



Measurement screen

There are four measurement screens available. Press **A** to change the screen.

Note:

You can change the screen pattern and the measurement items displayed for each screen.

 "Screen" on page 97

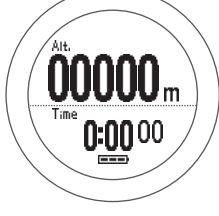
Screen	Screen Pattern (Default)	Measurement Item (Default)
Screen1		3 Lines Distance (Dist.) Split Time (Split) Average Pace (Av.Pace)
Screen2		2 Lines Lap Pace (LapPace) Lap Distance (LapDist.)
Screen3		3 Lines Distance (Dist.) Lap Time (Lap) Lap Distance (LapDist.)
Screen4		2 Lines Altitude (Alt.) Time (Time)

Measure

Lap Hold Screen

The Lap Hold Screen is displayed for 10 seconds when a lap is recorded.

Note:

You can change the screen pattern and the measurement items displayed.

 "Screen" on page 97

Screen	Screen Pattern (Default)	Screen Pattern (Default)	Measurement Item (Default)
Lap Hold Screen		2 Lines	Lap Distance (LapDist.) Lap Time (Lap)

Setting a Time and Distance for Hard and Light Workouts (Interval Function)

What is the Interval Function?

This function allows you to perform sets of hard (sprint) and light (rest) exercise.

You can set the time and distance, and create an exercise menu.

An alarm notifies you to change between sprint and rest times.

Sprint: Hard exercise

Rest: Light exercise

Repeat No.: Number of times to repeat one set of sprinting and resting

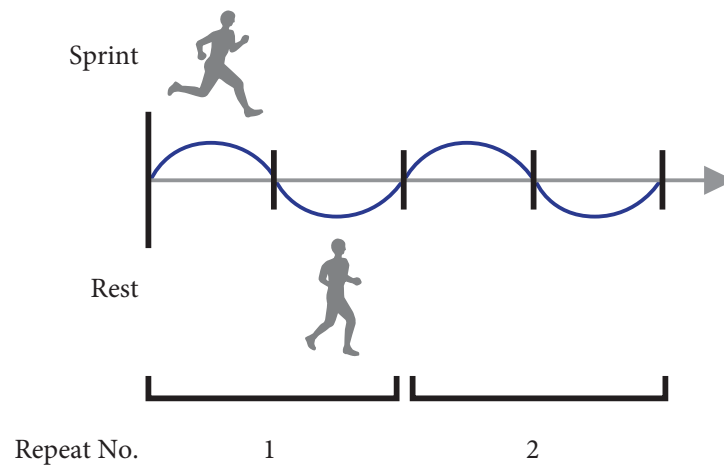

Setting Interval Conditions and Measuring

! Important:

- When performing GPS positioning, make sure the screen is facing up and you are outside with no obstructions overhead.

☞ “Specifying a GPS (GPS Positioning)” on page 29

- It usually takes less than two minutes to complete GPS positioning.

If GPS positioning is not complete after two minutes or **Failed** is displayed, we recommend selecting **Cancel**, moving to a different location, and trying again.

Operation buttons



Setting interval conditions

- 1 Display the measurement screen.
Press C on the time screen.

GPS positioning starts, and the measurement screen is displayed once positioning is complete.



Note:

- You can skip GPS positioning if you want to start measuring immediately or if it is taking too long.

☞ “Skipping GPS positioning” on page 30

- Use indoor mode when GPS positioning cannot be performed because you are inside and so on.

☞ “Indoor mode (SF-710/SF-510 only)” on page 31

- 2 Displays the **Mes. Settings** menu.

Hold down B on the measurement screen.

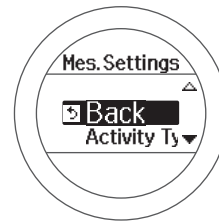

- 3 Select **Mode**.

Use C/D to select, and then press A.

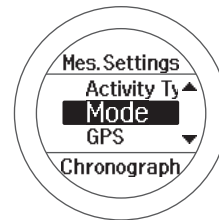

- 4 Select **Interval**.

Use C/D to select, and then press A.

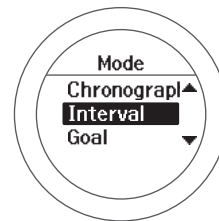

Measure

- 5** Select settings 1, 2, or 3.
Use **C/D** to select, and then press **A**.

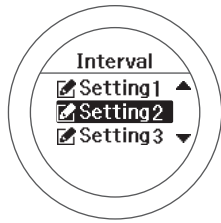

- 6** Select **Edit**.
Use **C/D** to select, and then press **A**.

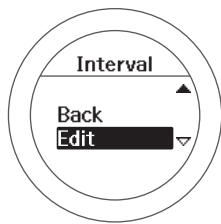

- 7** Select whether to set distance or time as the length of the sprint (hard exercise).
Use **C/D** to select, and then press **A**.

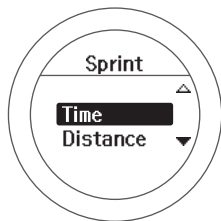

- 8** Set the time or distance.
Use **C/D** to set, and then press **A**.
Hold down **C/D** to speed through the numbers.

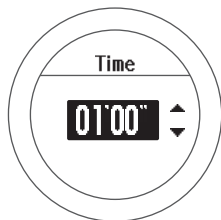

- 9** Set the heart rate zone you want to maintain while sprinting.
Use **C/D** to select, and then press **A**.

An alarm sounds if you are outside the set heart rate zone.

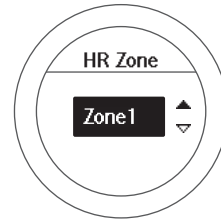

Note:
You can check or change the value set for the heart rate in each heart rate zone in **User Settings**.
[☞ "User Settings" on page 94](#)

- 10** Set the rest (light exercise).
Follow steps 7 to 9.

- 11** Set the Repeat No. (number of times to repeat one set of sprinting and resting).
Use **C/D** to set, and then press **A**.

Hold down **C/D** to speed through the numbers.

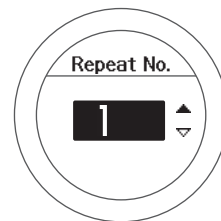

- 12** Check the set content.
After checking, press **A**.

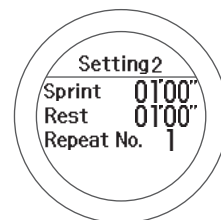

Measure

13 Select **OK**.

Use **C/D** to select, and then press **A**.

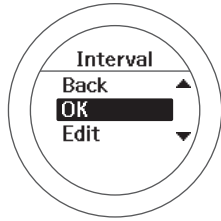

The interval measurement screen is displayed.

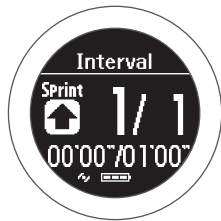

Measure

Measuring

1 Start measuring.

Press **C**.

Sprint measuring starts.

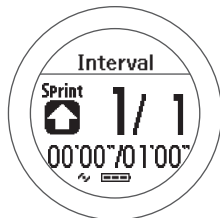

Measure

Loading Interval Conditions that have Already been Set

Important:

- When performing GPS positioning, make sure the screen is facing up and you are outside with no obstructions overhead.

☞ “Specifying a GPS (GPS Positioning)” on page 29

- It usually takes less than two minutes to complete GPS positioning.

If GPS positioning is not complete after two minutes or **Failed** is displayed, we recommend selecting **Cancel**, moving to a different location, and trying again.

Operation buttons



Loading interval conditions

- 1 Display the measurement screen.
Press C on the time screen.

GPS positioning starts, and the measurement screen is displayed once positioning is complete.



Note:

- You can skip GPS positioning if you want to start measuring immediately or if it is taking too long.

☞ “Skipping GPS positioning” on page 30

- Use indoor mode when GPS positioning cannot be performed because you are inside and so on.

☞ “Indoor mode (SF-710/SF-510 only)” on page 31

- 2 Displays the **Mes. Settings** menu.

Hold down B on the measurement screen.

- 3 Select **Mode**.

Use C/D to select, and then press A.

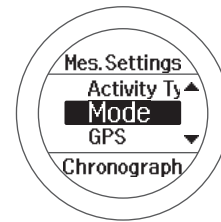

- 4 Select **Interval**.

Use C/D to select, and then press A.

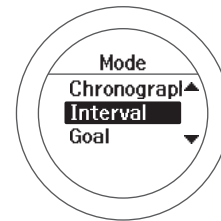

- 5 Select settings 1, 2, or 3.

Use C/D to select the previously made settings, and then press A.

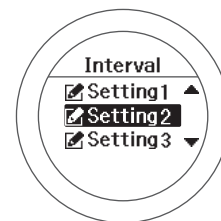

Measure

6 Check the set content.

Press A.



7 Select OK.

Use C/D to select, and then press A.

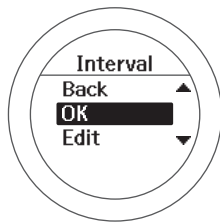

The interval measurement screen is displayed.

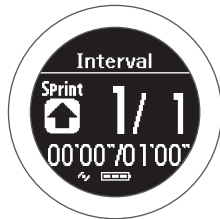
**Measuring**

See the following page for information on measuring.

 ["Measuring" on page 48](#)

Measure

Screen Display

There are five measurement screens available. Press **A** to change the screen.

Note:

You can change the screen pattern and the measurement items displayed for screens one to four.

 "Screen" on page 97

Screen	Screen Pattern (Default)	Measurement Item (Default)
Fixed interval screen		Time or distance for Sprint/Rest
Screen1		Distance (Dist.) Split Time (Split) Average Pace (Av.Pace)
Screen2		Lap Pace (LapPace) Lap Distance (LapDist.)
Screen3		Distance (Dist.) Lap Time (Lap) Lap Distance (LapDist.)
Screen4		Altitude (Alt.) Time (Time)

Measure

Measure until the time or distance set in advance is reached (Goal function)

What is the goal function?

This function measures until the time or distance set in advance is reached.

Time race

Allows you to set a time as your goal and measure the time taken until that goal is reached. You can exercise while checking your progress and the elapsed time. You can also calculate the estimated distance.

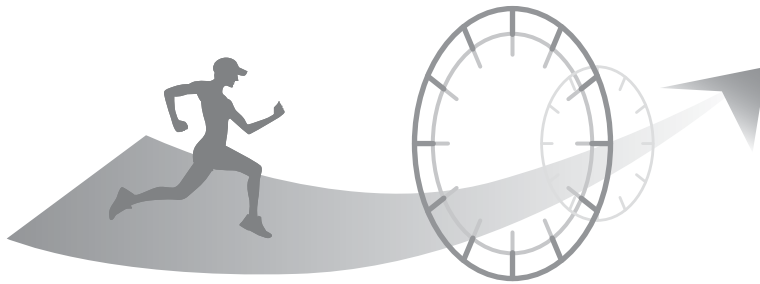

Distance race

Allows you to set a distance as your goal and measure the time taken until that goal is reached. You can exercise while checking your progress and distance traveled. You can also calculate the estimated time.



Measure

Setting the Time or Distance and Measuring

Important:

- When performing GPS positioning, make sure the screen is facing up and you are outside with no obstructions overhead.

☞ “Specifying a GPS (GPS Positioning)” on page 29

- It usually takes less than two minutes to complete GPS positioning.

If GPS positioning is not complete after two minutes or **Failed** is displayed, we recommend selecting **Cancel**, moving to a different location, and trying again.

Operation buttons



Set the time or distance.

- 1 Display the measurement screen.
Press C on the time screen.

GPS positioning starts, and the measurement screen is displayed once positioning is complete.



Note:

- You can skip GPS positioning if you want to start measuring immediately or if it is taking too long.

☞ “Skipping GPS positioning” on page 30

- Use indoor mode when GPS positioning cannot be performed because you are inside and so on.

☞ “Indoor mode (SF-710/SF-510 only)” on page 31

- 2 Displays the **Mes. Settings** menu.

Hold down B on the measurement screen.

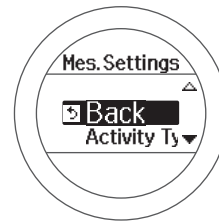

- 3 Select **Mode**.

Use C/D to select, and then press A.

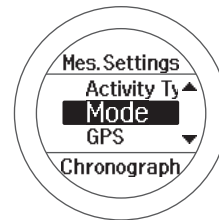

- 4 Select **Goal**.

Use C/D to select, and then press A.

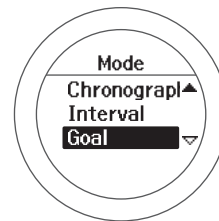

Measure

- 5 Select whether to set time or distance.

Use **C/D** to select, and then press **A**.

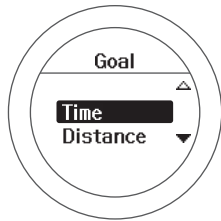

- 6 Set the time or distance.

Use **C/D** to set, and then press **A**.

Hold down **C/D** to speed through the numbers.

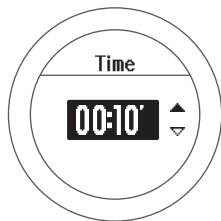

- 7 Select **OK**.

Use **C/D** to select, and then press **A**.

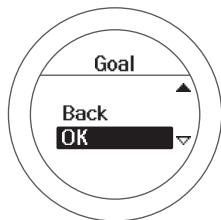

The goal measurement screen is displayed.



Measuring

- 1 Start measuring.

Press **C**.



- 2 When the set time or distance is reached, the "Finish" screen is displayed.

The time, distance, and calories burnt are displayed.



Note:
An alarm notifies you when you reach 50% and 90% of the set time or distance.

- 3 Stop measuring.

Press **C** while measuring.



- 4 Reset the measurement results.

Hold down **D** while measuring is stopped.

Measure

When you reset the display, it returns to the status before measuring started allowing you to start the next measurement.



Data measured up to that point is stored in the device's memory, and you can check it by pressing **D** on the time screen.

[🔗](#) “Checking Measurement Data” on page 64

Note:

- After resetting the measurement results, hold down **A** to display the time screen.
- If you hold down **C** while measuring is stopped, the measurement results are reset and the time screen is displayed.
- If no operations are made for 60 minutes, the time screen is displayed.

Measure

Screen Display

There are five measurement screens available. Press **A** to change the screen.

Note:

You can change the screen pattern and the measurement items displayed for screens one to four.

 "Screen" on page 97

Screen	Screen Pattern (Default)	Measurement Item (Default)
Fixed goal screen		Goal Time or distance for Goal
Screen1		3 Lines Distance (Dist.) Split Time (Split) Average Pace (Av.Pace)
Screen2		2 Lines Lap Pace (LapPace) Lap Distance (LapDist.)
Screen3		3 Lines Distance (Dist.) Lap Time (Lap) Lap Distance (LapDist.)
Screen4		2 Lines Altitude (Alt.) Time (Time)

Measure

Recording Laps Automatically (AT Lap Function)

When a time or distance is set in advance, laps are recorded automatically.

Set the lap time or distance. You can set five times or distances. However, only one setting can be used while measuring.

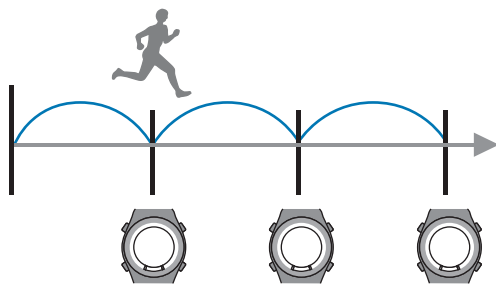

! Important:

- ❑ When performing GPS positioning, make sure the screen is facing up and you are outside with no obstructions overhead.
 - 🔗 “Specifying a GPS (GPS Positioning)” on page 29
- ❑ It usually takes less than two minutes to complete GPS positioning.
 - If GPS positioning is not complete after two minutes or **Failed** is displayed, we recommend selecting **Cancel**, moving to a different location, and trying again.

Operation buttons



- 1** Display the measurement screen.
Press C on the time screen.

GPS positioning starts, and the measurement screen is displayed once positioning is complete.



Note:

- ❑ You can skip GPS positioning if you want to start measuring immediately or if it is taking too long.
 - 🔗 “Skipping GPS positioning” on page 30
- ❑ Use indoor mode when GPS positioning cannot be performed because you are inside and so on.
 - 🔗 “Indoor mode (SF-710/SF-510 only)” on page 31

- 2** Displays the **Mes. Settings** menu.
Hold down B on the measurement screen.

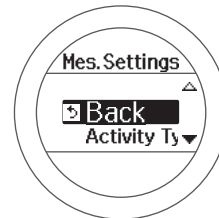

- 3** Select **AT Lap**.
Use C/D to select, and then press A.

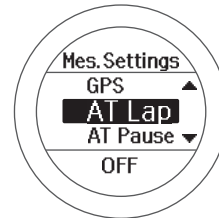

Measure

4 Select settings 1, 2, or 5.

Use **C/D** to select, and then press **A**.

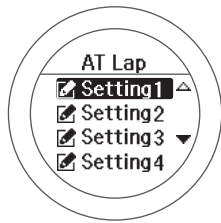

5 Select whether to set distance or time as the length of the lap.

Use **C/D** to select, and then press **A**.

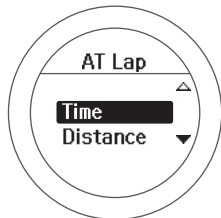

6 Set the time or distance.

Use **C/D** to set, and then press **A**.

Hold down **C/D** to speed through the numbers.

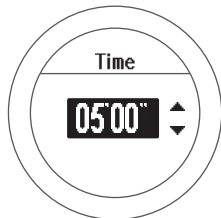

7 This completes the settings.

Hold down **A**.

The measurement screen is displayed.

Note:

To turn off this function, select **OFF** in step 4.

Measure

Automatically Start/Stop Measuring (AT Pause Function)

Automatically stops measuring when you stop running, and resumes when you continue running.

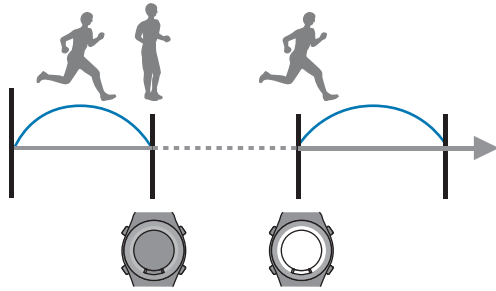

! Important:

- ❑ When performing GPS positioning, make sure the screen is facing up and you are outside with no obstructions overhead.
 - 🔗 [“Specifying a GPS \(GPS Positioning\)” on page 29](#)
- ❑ It usually takes less than two minutes to complete GPS positioning.
 - If GPS positioning is not complete after two minutes or **Failed** is displayed, we recommend selecting **Cancel**, moving to a different location, and trying again.

Operation buttons



- 1** Display the measurement screen.
Press C on the time screen.

GPS positioning starts, and the measurement screen is displayed once positioning is complete.



Note:

- ❑ You can skip GPS positioning if you want to start measuring immediately or if it is taking too long.
 - 🔗 [“Skipping GPS positioning” on page 30](#)
- ❑ Use indoor mode when GPS positioning cannot be performed because you are inside and so on.
 - 🔗 [“Indoor mode \(SF-710/SF-510 only\)” on page 31](#)

- 2** Displays the **Mes. Settings** menu.
Hold down B on the measurement screen.

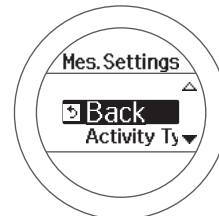

- 3** Select **AT Pause**.
Use C/D to select, and then press A.

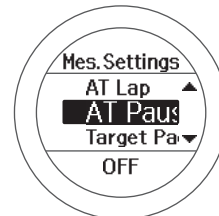

Measure

4 Select **ON**.

Use **C/D** to select, and then press **A**.

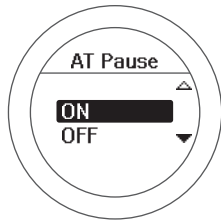

5 This completes the settings.

Hold down **A**.

The measurement screen is displayed.

Note:

To turn off this function, select **OFF** in step 4.

Setting a Pace and Measuring (Target Pace Function)

If you fall behind the pace set as the target pace during measuring, an alarm sounds.

When you fall behind the target pace, you can set a range for the alarm for completing your target time (target pace) of around one kilometer.

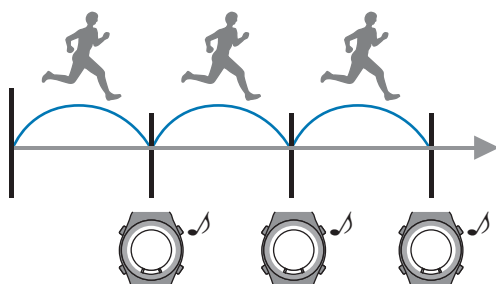

! Important:

- When performing GPS positioning, make sure the screen is facing up and you are outside with no obstructions overhead.
 - “Specifying a GPS (GPS Positioning)” on page 29
- It usually takes less than two minutes to complete GPS positioning.
 - If GPS positioning is not complete after two minutes or **Failed** is displayed, we recommend selecting **Cancel**, moving to a different location, and trying again.

Operation buttons



- 1 Display the measurement screen.
Press C on the time screen.

GPS positioning starts, and the measurement screen is displayed once positioning is complete.



Note:

- You can skip GPS positioning if you want to start measuring immediately or if it is taking too long.
 - “Skipping GPS positioning” on page 30
- Use indoor mode when GPS positioning cannot be performed because you are inside and so on.
 - “Indoor mode (SF-710/SF-510 only)” on page 31

- 2 Displays the **Mes. Settings** menu.
Hold down B on the measurement screen.

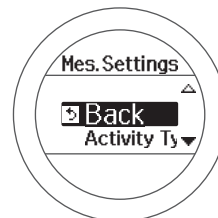

- 3 Select **Target Pace**.
Use C/D to select, and then press A.

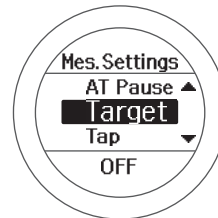

Measure

- 4** Select settings 1, 2, or 3.

Use **C/D** to select, and then press **A**.



- 5** Set the target time for one kilometer.

Use **C/D** to set, and then press **A**.

Hold down **C/D** to speed through the numbers.



- 6** Set the range for maintaining your target pace.

Use **C/D** to set, and then press **A**.

Hold down **C/D** to speed through the numbers.

An alarm sounds if you are outside the set pace range.

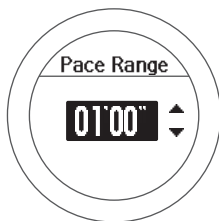

- 7** This completes the settings.

Hold down **A**.

The measurement screen is displayed.

Note:

If you want to turn off the alarm that notifies you when you are falling behind the set pace range, select **OFF** in step 6. **OFF** is the bottom line for the **Pace Range** (under 0'05").

Checking Measurement Data (History Function)

Checking Measurement Data (History Function)

You can check measured data on the history screen.

 ["Checking Measurement Data" on page 64](#)

 ["Measurement Data that can be Checked in History" on page 64](#)

Checking Measurement Data (History Function)

Checking Measurement Data

You can check measured data on the history screen.

Operation buttons



- 1 Display the history list screen.
Press **D** on the time screen.



- 2 Highlight the data you want to check.
The history list screen displays item icons, the measurement day, and the distance.
Use **C/D** to select, and then press **A**.



- 3 Check the measurement data.
Use **C/D** to scroll the screen.

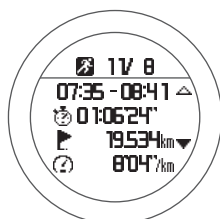

- 4 After checking, display the history list screen.
Press **A**.
- 5 Finish checking the history.
Hold down **A**.
Displays the time screen.

Measurement Data that can be Checked in History

The following measurement data can be checked.

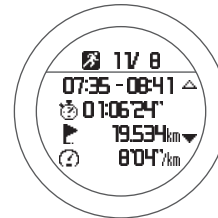

Icon	
	Run mode (measuring while running)
	Walking mode (measuring while walking)
	Bike mode (measuring while riding a bike)

Measurement item	
-	Measurement day
-	Start Time/End Time
	Split time
	Distance
	Average pace
	Calories Burnt
	Lap number
-	Lap pace

Checking Measurement Data (History Function)

To clear the history, you need to initialize the device. When initializing, all setting information for **User Settings**, **Sys. Settings**, and **Mes. Settings** is also initialized along with the history information.

 [“Sys. Settings” on page 95](#)

Measuring Heart Rate (HR Monitor)

Measuring Heart Rate (HR Monitor)

You can measure your heart rate by using the optional HR monitor.

 ["Preparing to Measure Heart Rate" on page 67](#)

 ["Measuring Heart Rate" on page 72](#)

 ["Replacing the Battery for the HR Monitor" on page 74](#)

Measuring Heart Rate (HR Monitor)

Preparing to Measure Heart Rate

Preparing the HR Monitor

The HR monitor can be purchased as an optional item. Contact your local dealer to purchase an HR monitor.

HR Monitor (Model No.: SFHRM01)

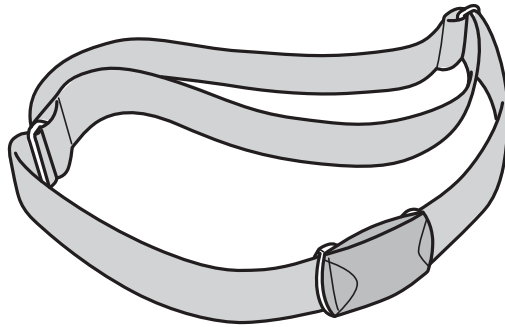

The HR monitor communicates with the device using Bluetooth® Smart technology.

Wearing the HR Monitor

Wear the HR belt so that the electrode section of the HR belt is pressed against your chest. Make sure it is attached correctly to avoid losing data.

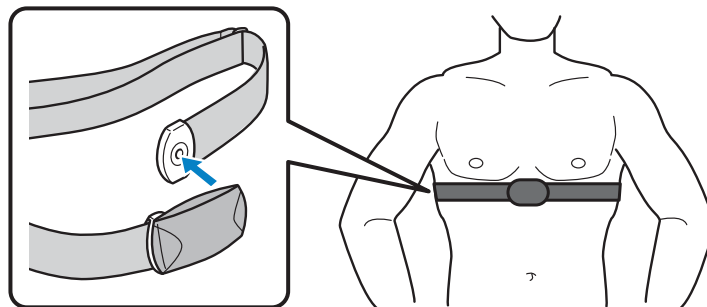

Note:

You can perform stable measurements when the electrode section of the HR belt is a little wet.

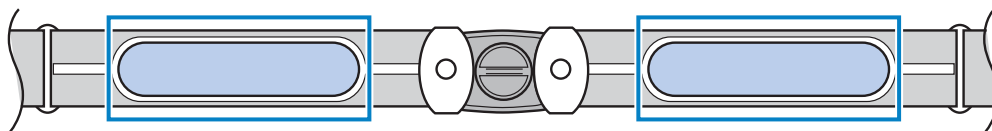

Measuring Heart Rate (HR Monitor)

Registering the HR Monitor to the Device

When using the HR monitor for the first time, wear the HR monitor when you register it to the device.

Operation buttons



Important:

Check that there are no other HR monitors in the surrounding area before registering.

1

Displays the **Settings** menu.

Hold down **B** on the time screen.

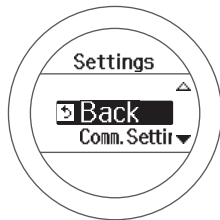

2

Select **Comm. Settings**.

Use **C/D** to select, and then press **A**.

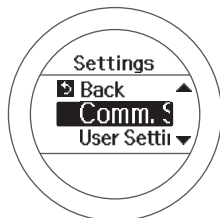

3

Select **HR Monitor**.

Use **C/D** to select, and then press **A**.

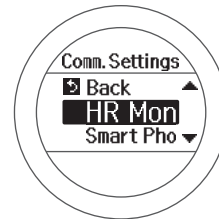

4

Select **Register**.

Use **C/D** to select, and then press **A**.



The device starts searching for the HR monitor and displays the search results.

5

Select the registered HR monitor.

Use **C/D** to select, and then press **A**.



6

This completes the communication settings.

Press **A**.

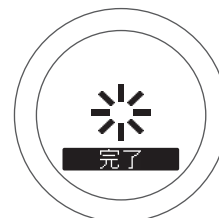

7

This completes the settings.

Hold down **A**.

Displays the time screen.

Measuring Heart Rate (HR Monitor)

Note:

If communication cannot be established, reset the HR monitor.

 *“Replacing the Battery for the HR Monitor” on page 74*

Measuring Heart Rate (HR Monitor)

Enabling the HR Monitor

When using the HR monitor, set **HR** to **ON** from the **Mes. Settings** menu.

! Important:

- When performing GPS positioning, make sure the screen is facing up and you are outside with no obstructions overhead.

☞ “Specifying a GPS (GPS Positioning)” on page 29

- It usually takes less than two minutes to complete GPS positioning.

If GPS positioning is not complete after two minutes or **Failed** is displayed, we recommend selecting **Cancel**, moving to a different location, and trying again.

Operation buttons



- 1 Display the measurement screen.

Press **C** on the time screen.

GPS positioning starts, and the measurement screen is displayed once positioning is complete.



Note:

- You can skip GPS positioning if you want to start measuring immediately or if it is taking too long.

☞ “Skipping GPS positioning” on page 30

- Use indoor mode when GPS positioning cannot be performed because you are inside and so on.

☞ “Indoor mode (SF-710/SF-510 only)” on page 31

- Screens are explained using the default screens. You can invert the screen's monochrome display.

☞ “Sys. Settings” on page 95

- 2 Displays the **Mes. Settings** menu.

Hold down **B** on the measurement screen.

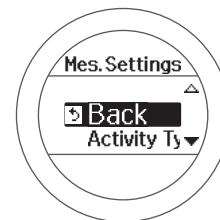

- 3 Select **HR**.

Use **C/D** to select, and then press **A**.

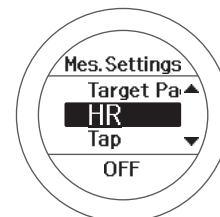

- 4 Select **ON**.

Use **C/D** to select, and then press **A**.



Measuring Heart Rate (HR Monitor)

- 5** Set the heart rate zone you want to maintain while exercising.

Use **C/D** to select, and then press **A**.

An alarm sounds if you are outside the set heart rate zone.

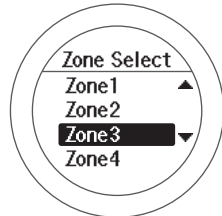

Note:

You can check or change the value set for the heart rate in each heart rate zone in **User Settings**.

 ["User Settings" on page 94](#)

- 6** Check the set content.

Press **A**.

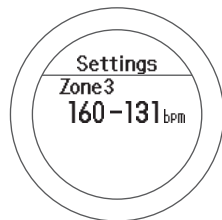

- 7** This completes the settings.

Hold down **A**.

The measurement screen is displayed.

Note:

- When **HR** is set to **ON**, the battery life for the device is reduced. When you are not using the HR monitor, set **HR** to **OFF**.
- If you want to turn off the alarm that notifies you when you are outside the set heart rate zone, select **OFF** in step 5.

Measuring Heart Rate (HR Monitor)

Measuring Heart Rate

When **HR** is set to **ON** from the **Mes. Settings** menu, you can use the HR monitor to measure heart rate in the chronograph, interval, and goal functions. See the following pages for information on each function.

 [“Measuring Time, Distance, and Speed \(Chronograph Function\)” on page 39](#)

 [“Setting a Time and Distance for Hard and Light Workouts\(Interval Function\)” on page 44](#)

 [“Measure until the time or distance set in advance is reached \(Goal function\)” on page 52](#)

Checking the Communication Status with the HR Monitor

You can check the communication status of the HR monitor from the icon on the measurement screen.

If  is flashing, check that you are wearing the HR monitor correctly.

Measurement screen: Chronograph



 On: Communicating with the HR monitor.

 Flashing: Cannot communicate with the HR monitor.

Displaying the Measured Heart Rate Screen

The heart rate measurement item is not displayed by default. Change the screen settings to display the heart rate item.

 [“Screen” on page 97](#)

List of measurement items displayed (items related to heart rate)

Display item	Display name		Explanation
	1 Line	2 Lines/3 Lines	
HR	HR	HR	Current heart rate
Average HR	Avg.HR	Av.HR	Average heart rate from the start of measurements
Maximum HR*	Max.HR	Max.HR	Maximum heart rate from the start of measurements

Measuring Heart Rate (HR Monitor)

Display item	Display name		Explanation
	1 Line	2 Lines/3 Lines	
Lap HR	LapHR	LapHR	Average heart rate for each lap
HR Zone Time*	Spent.HR	Spent.HR	Time within heart rate zone for each lap
Time to HR Zone*	Time.HR	Time.HR	Time until entering heart rate zone for each lap

* Only displayed for the SF-710/SF-510.

Measuring Heart Rate (HR Monitor)

Replacing the Battery for the HR Monitor

If you cannot measure your heart rate, the HR monitor battery may have run out. Replace the battery.

The HR monitor uses a lithium battery (CR2032).

- 1 Use something flat, such as a coin, to remove the battery cover.

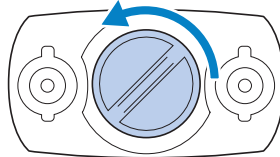
**Note:**

You can avoid damaging the cover by wrapping the coin in a thin handkerchief and so on.

- 2 Remove the battery, and reset the HR monitor.

Remove the battery.

Turn the battery over so that the negative side is facing up and replace it, and then wait for at least three seconds.

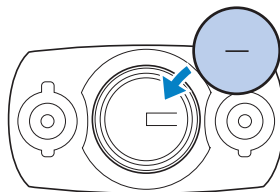
**Note:**

What is the HR monitor reset:

Any remaining charge in the HR sensor circuitry is dispersed by removing the battery, reinserting it with the negative side facing up, and waiting for at least three seconds.

If the HR monitor temporarily freezes, you can reset it by using this method.

- 3 Insert a new battery.

Make sure the + side is facing up.

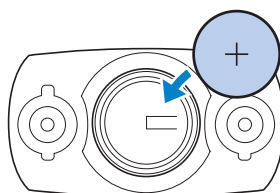

Measuring Heart Rate (HR Monitor)

- 4** Replace the battery cover.

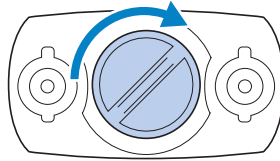

Important:

If the internal packing has come out, close the cover after putting it back in its original position. If the packing gets caught when closing the cover, it could be damaged and sweat or water could enter into the device causing a malfunction.

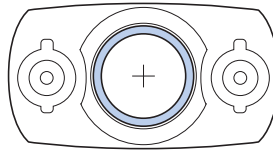

Data Management Using the Web Application (NeoRun)

This device allows you to manage measured data using a dedicated Web application (NeoRun).

The Web application (NeoRun) allows you to review your running route, distance, speed, heart rate, calories burnt, and so on.

Note:

You need to make an account the first time you use NeoRun.

 *“Creating an Account (When Using for the First Time)” on page 80*

If you already have an account with NeoRun, you can continue using it with this device.

 **“What is the Web Application (NeoRun)” on page 77**

 **“Installing the NR Uploader” on page 79**

 **“Creating an Account (When Using for the First Time)” on page 80**

 **“Checking Uploaded Measurement Data” on page 84**

Data Management Using the Web Application (NeoRun)

What is the Web Application (NeoRun)

The Web application (NeoRun) sends measurement data through your computer allowing you to manage your running route, distance, speed, heart rate, calories burnt, and so on.

You can also use this for data analysis as the sent data can be displayed in various formats, such as a map display for the route, a graph showing speed/distance, a total display (for months/entire periods).

By exporting in GPX format, you can also use the measurement data on other applications.

Home screen



Manage records in calendar format. Allows you to easily review past runs.

Training record screen

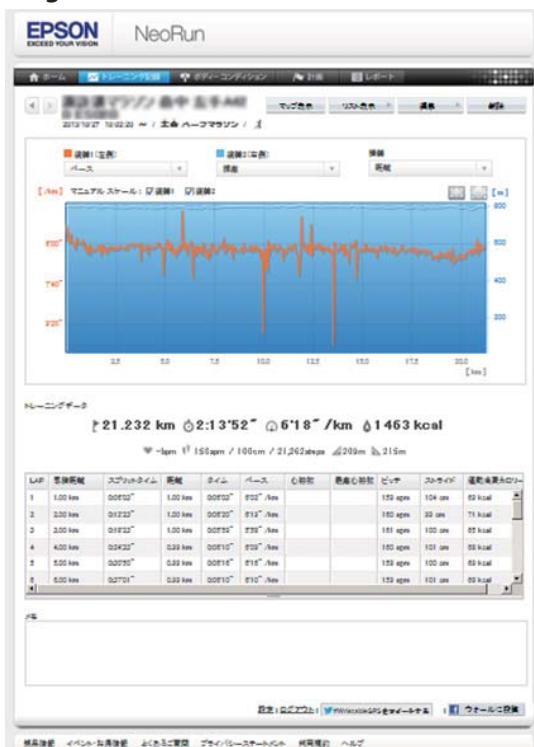

Displays the pace/speed, altitude, heart rate, and so on as a graph. Allows you to analyze training from different angles.

Data Management Using the Web Application (NeoRun)

Body condition screen



Displays changes in weight, body fat, calories burnt through exercise as a graph. Allows you to record, manage, and check your physical condition.

Training map screen



By using the built-in GPS function, you can review running routes you have left on the map, as well as running courses in competitions or targets you reached.

Data Management Using the Web Application (NeoRun)

Installing the NR Uploader

You need NR Uploader to upload measurement data to the Web application (NeoRun).

Follow the steps below to install NR Uploader.



Important:

Use NR Uploader Ver. 2.0 or later. You can use Ver. 2.0 with the SS series.

1

Access the following Web site and download NR Uploader.

<http://www.epson.jp/download/>

2

Run the downloaded file.

The Setup screen is displayed.

3

Select **I accept the terms in the License Agreement**, and then click **Install**.

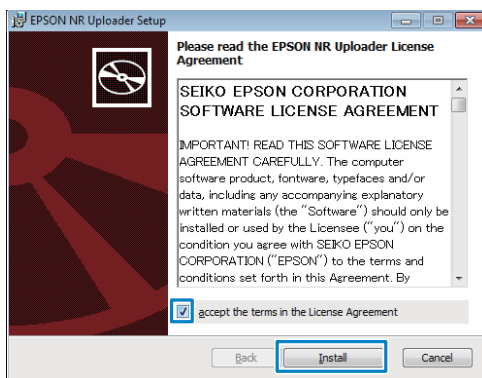

Installation starts.

Follow the on-screen instructions until the installation complete screen is displayed.

If a security message is displayed, simply continue with the installation.

4

When the completion screen is displayed, click **Finish**.

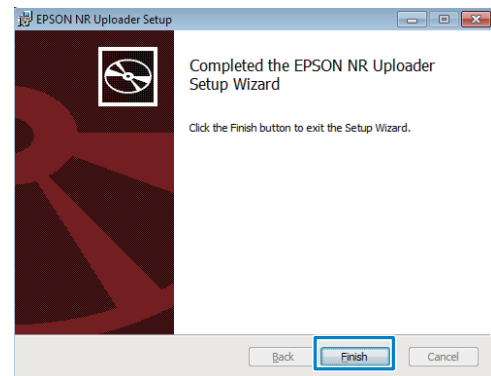

5

When a screen is displayed asking you to reboot your computer, click **Yes** to reboot.

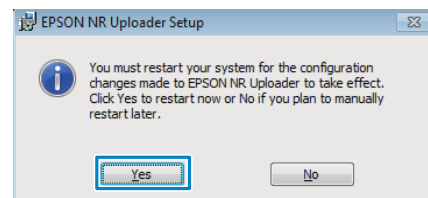

Installation is complete.

Data Management Using the Web Application (NeoRun)

Creating an Account (When Using for the First Time)

You need to create an account with the Web application (NeoRun) when using it for the first time.

- 1 Connect the cradle to the computer on which NR Uploader is installed.

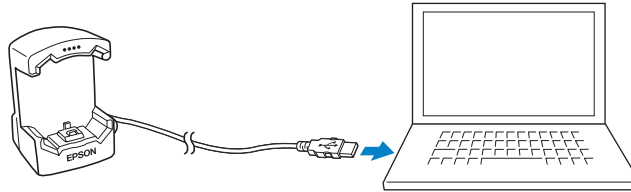

- 2 Place the device into the cradle.

Check that the contact points on the device are pointing up and match the contact marks on the cradle, and then press straight down until it is fixed in place.

After placing the bottom of the device into the cradle, push carefully on the top of the device.

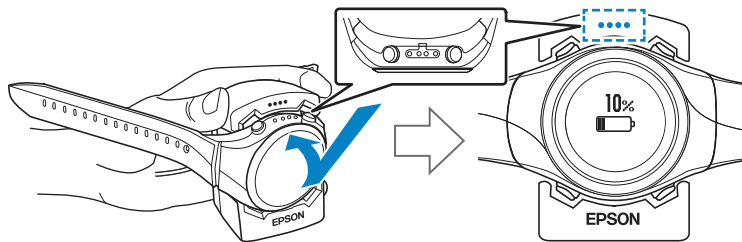

Important:

Make sure the device is placed in the correct direction. Otherwise the cradle could be damaged.

NR Uploader starts.

Note:

If NR Uploader does not start, disconnect the cable from the cradle, wait a few seconds, and then reconnect. Do not remove the device from the cradle.

Data Management Using the Web Application (NeoRun)

3 Click **Create Account**.

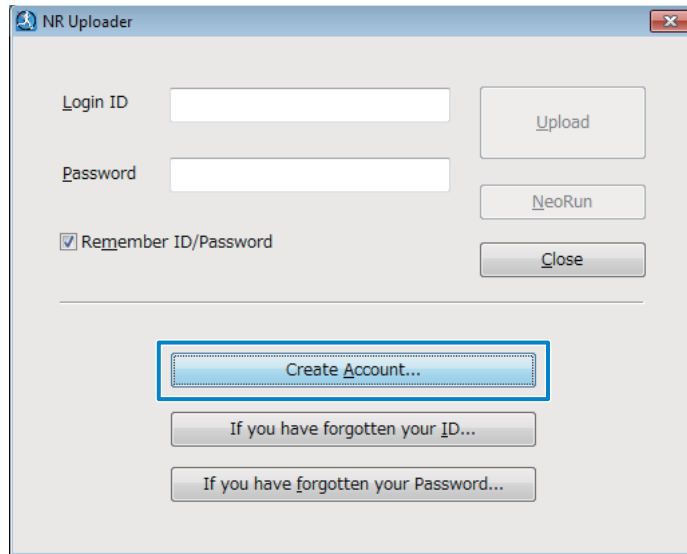

4 Create an account.

Enter information for the **Login ID**, **Password**, and **Email Address**, and then click **Create Account**.

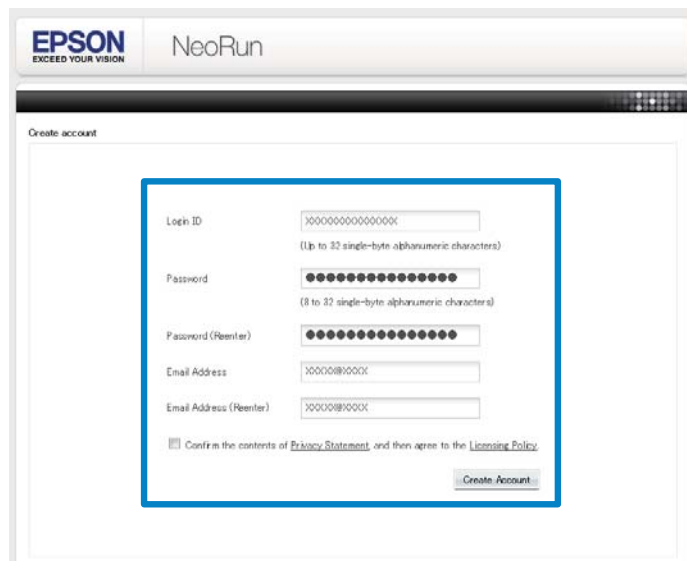

To upload measurement data, go to step 3 in the following section.

[“Uploading Measurement Data” on page 82](#)

Data Management Using the Web Application (NeoRun)

Uploading Measurement Data

You can upload measurement data to the Web application (NeoRun).

- 1 Connect the cradle to the computer on which NR Uploader is installed.

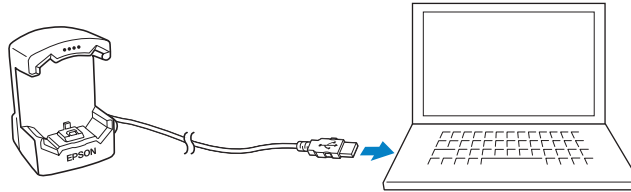

- 2 Place the device into the cradle.

Check that the contact points on the device are pointing up and match the contact marks on the cradle, and then press straight down until it is fixed in place.

After placing the bottom of the device into the cradle, push carefully on the top of the device.

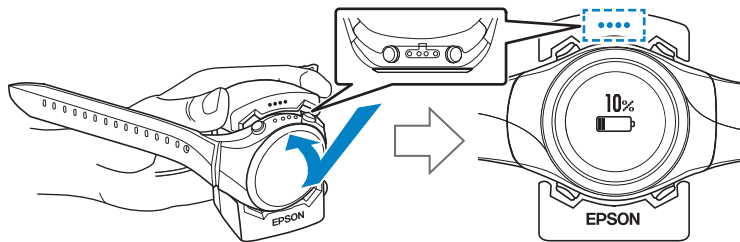

Important:

Make sure the device is placed in the correct direction. Otherwise the cradle could be damaged.

NR Uploader starts.

- 3 Enter your **Login ID** and **Password** on the NR Uploader screen, and then click **Upload**.

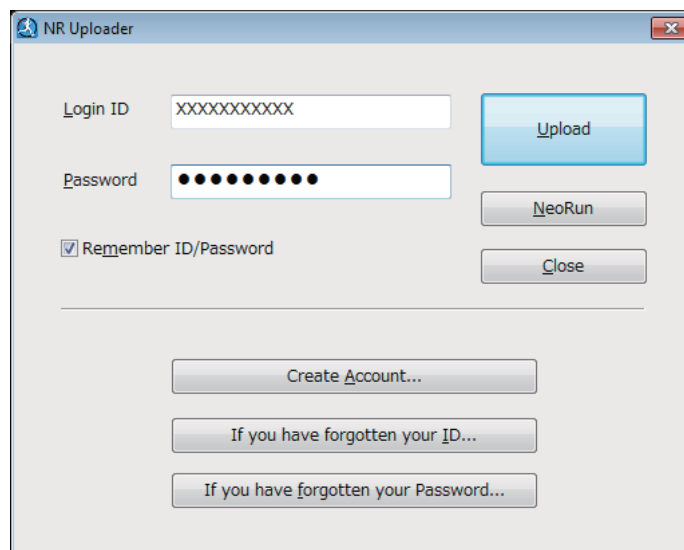

Data Management Using the Web Application (NeoRun)

Data is uploaded to the Web application (NeoRun).

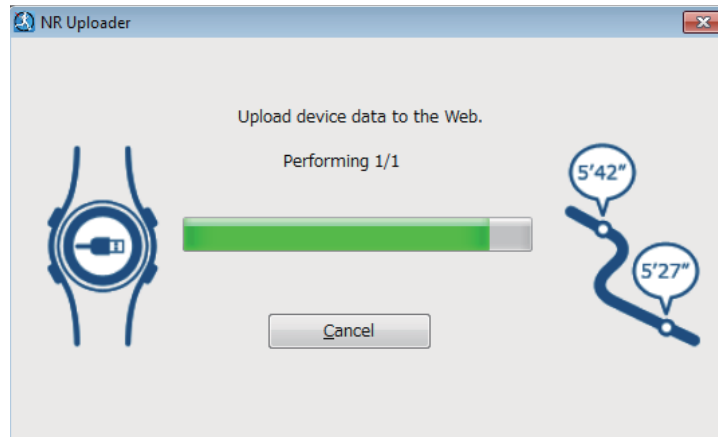

When the upload is complete, the Web application (NeoRun) starts and the Home screen is displayed.

Checking Uploaded Measurement Data

Access the Web application (NeoRun) to check uploaded measurement data.

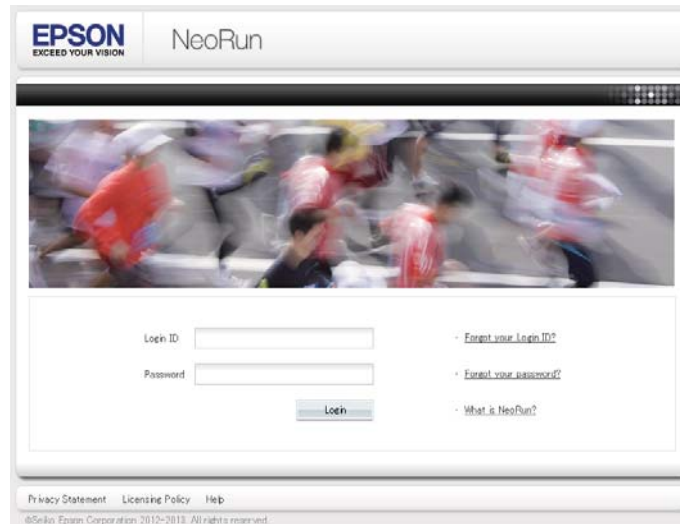
**1**

Start NeoRun.

Use one of the following methods to start NeoRun.

■ **Access the following Web site.**

<https://go-wellness.epson.com/neo-run/>

■ **Start from the NR Uploader icon on your computer.**

Right-click the NR Uploader icon from the Windows desktop taskbar, and then select **NeoRun**.

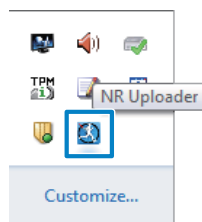

Data Management Using the Web Application (NeoRun)

■ **Click NeoRun on the NR Uploader screen.**

The NR Uploader screen is displayed when you place the device in the cradle connected to the computer.

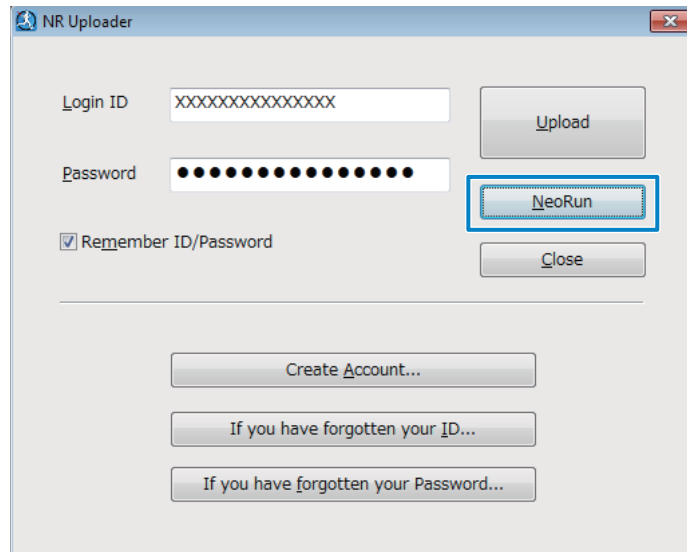

The Web application (NeoRun) starts and the Home screen is displayed. Go to step 3.

Note:

The **NeoRun** button is not available in the following circumstances.

- When the login ID and password have not be saved or entered.
- When the device has been removed from the cradle.

2

Enter the **Login ID** and **Password**, and then click **Login**.

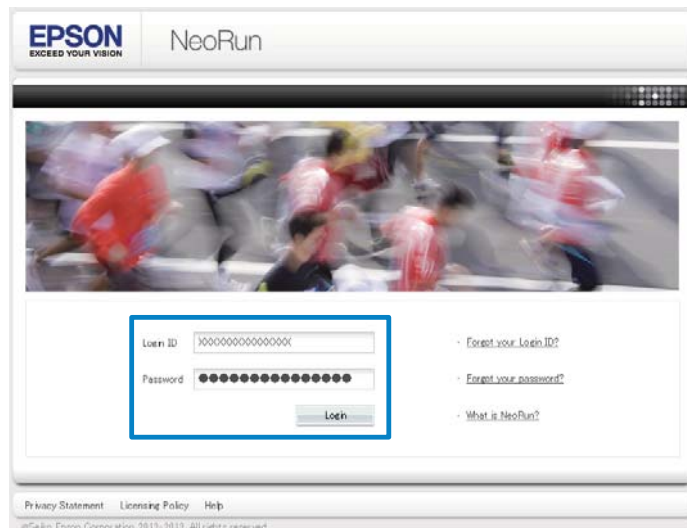

Data Management Using the Web Application (NeoRun)

3

Click the data you want to check from the uploaded data.

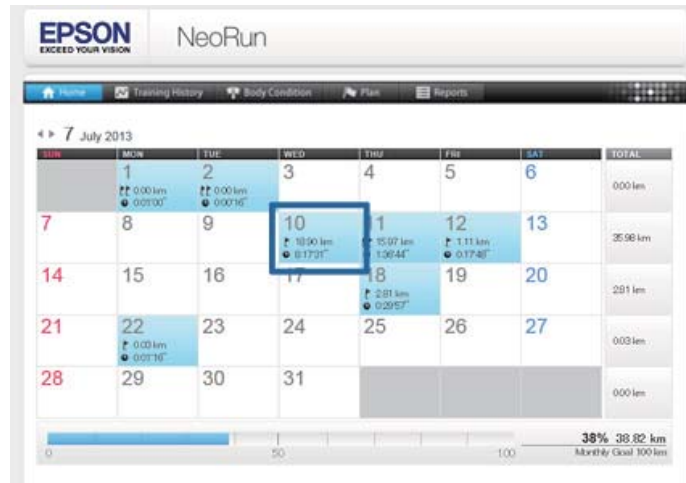

Note:

For information on using the Web application (NeoRun), see the NeoRun Help.

Settings

Settings

You can change a variety of measurement or device settings. Make settings to suit the way you use the device.

 ["Making Settings" on page 88](#)

 ["Mes. Settings" on page 89](#)

 ["Settings" on page 93](#)

 ["Screen" on page 97](#)

Settings

Making Settings

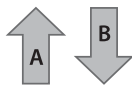
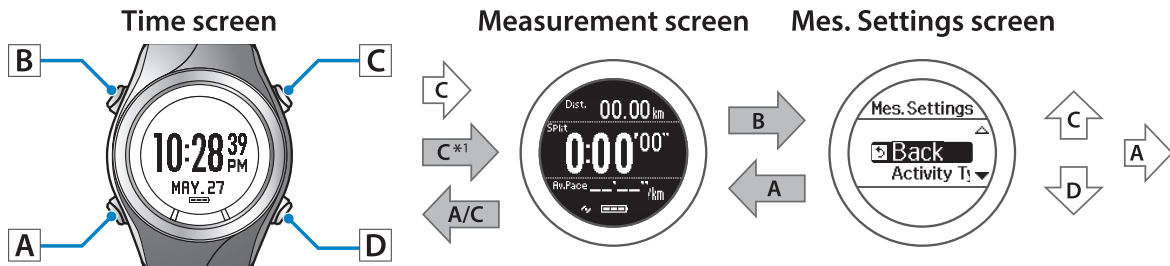

*1 : Indoor mode
SF-710/SF-510 only

Settings screen

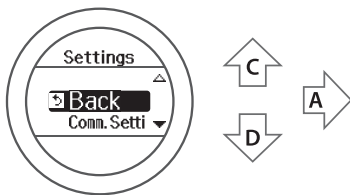

Settings menu

Comm. Settings	HR Monitor Smartphone	Settings
User Settings	Height Weight DOB Gender HR Zone	Settings
Sys. Settings	Language Units Clock DST Time Adjust Time Zone Date Format Invert Disp. Contrast Auto Sleep Auto Light Alarm Operation Tones Initialize Software Version	Settings

Hold down A to display the time screen.

Mes. Settings menu

Activity Type Mode GPS AT Lap AT Pause Target Pace HR*2 Tap*3 Screen	Settings
--	-----------------

*2 : Displayed after registering the HR monitor.
*3 : SF-710/SF-510 only

Hold down A to display the measurement screen.

Mes. Settings

Allows you to change the measurement settings.

Changing the Mes. Settings

! Important:

- ❑ When performing GPS positioning, make sure the screen is facing up and you are outside with no obstructions overhead.
☞ “Specifying a GPS (GPS Positioning)” on page 29
- ❑ It usually takes less than two minutes to complete GPS positioning.
*If GPS positioning is not complete after two minutes or **Failed** is displayed, we recommend selecting **Cancel**, moving to a different location, and trying again.*

Operation buttons



- 1** Display the measurement screen.
Use one of the following methods to display.
 - ❑ When performing GPS positioning:
Press **C** on the time screen.
 - ❑ When skipping GPS positioning:
Press **C** on the time screen, and then select **Skip** on the GPS positioning screen.
☞ “Skipping GPS positioning” on page 30
 - ❑ When not performing GPS positioning (Indoor mode: SF-710/SF-510 only):
Press **C** on the time screen.

☞ “Indoor mode (SF-710/SF-510 only)” on page 31



- 2** Displays the **Mes. Settings** menu.
Hold down **B** on the measurement screen.

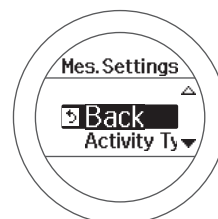

- 3** Select a setting item.
Use **C/D** to select, and then press **A**.

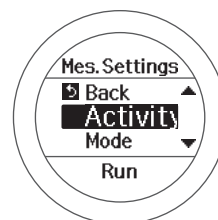

- 4** Select a setting value.
Use **C/D** to select, and then press **A**.

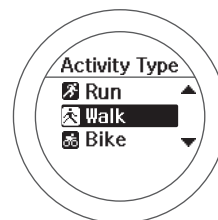

Depending on the setting item, you may need to make more settings after this. Follow the on-screen instructions.

Note:
When setting a number, hold down **C/D** to speed through the numbers.

Settings

5 This completes the settings.

Hold down **A**.

The measurement screen is displayed.

Note:



*On the screen displayed after resetting measurements, hold down **A** to display the time screen.*

Settings

Mes. Settings Table

Setting items	Value	Explanation
Activity Type	Run (default)	Set when running or jogging.
	Walk	Set when walking (exercising at a slow pace).
	Bike	Set when performing exercises that do not require you to swing your arms, such as riding a bike. We recommend setting Bike mode when in vehicles such as cars or trains.
Mode	Chronograph (default)	Set the mode to suit the measurements you want to make.
	Interval	Chronograph mode allows you to measure split times and lap times (section measurement) simultaneously.
	Goal	<p>🔗 “Measuring Time, Distance, and Speed (Chronograph Function)” on page 39</p> <p>Interval mode allows you to repeat sets of hard (sprint) or light (rest) exercises that have been set to last for a specific distance or time in advance.</p> <p>🔗 “Setting a Time and Distance for Hard and Light Workouts(Interval Function)” on page 44</p> <p>Goal mode measures until the time or distance set in advance is reached.</p> <p>🔗 “Measure until the time or distance set in advance is reached (Goal function)” on page 52</p>
GPS	-	Displays the number of GPS satellites being accessed.
AT Lap	Setting1	When a time or distance is set in advance, this function records laps automatically.
	Setting2	Set the lap time or distance.
	Setting3	You can set five times or distances.
	Setting4	🔗 “Recording Laps Automatically (AT Lap Function)” on page 57
	Setting5	
	OFF (default)	
AT Pause	ON	This function automatically stops measuring when you stop running, and resumes when you continue running.
	OFF (default)	🔗 “Automatically Start/Stop Measuring (AT Pause Function)” on page 59
Target Pace	Setting1	Set the target time and pace range for one kilometer. An alarm sounds if you are outside the set pace range.
	Setting2	You can set three target paces.
	Setting3	🔗 “Setting a Pace and Measuring (Target Pace Function)” on page 61
	OFF (default)	
HR*1	ON	You can measure your heart rate by wearing the HR monitor (optional).
	OFF (default)	🔗 “Measuring Heart Rate” on page 72

Settings

Setting items	Value	Explanation
Tap* ² (Only for the measurement screen)	Lap	<p>You can perform one of the operations set here by tapping the screen once while measuring.</p> <p>When Bike is selected as the Activity Type, the tap function may operate automatically depending on the condition of the road surface. If this occurs, we recommend setting OFF.</p> <p> "Tap" on page 21</p>
	Light	
	Screen Chg.	
	OFF (default)	
Screen	Screen1	<p>There are four measurement screens that can be displayed. You can change the screen pattern and the measurement items displayed for each screen.</p> <p>You can also change the Lap Hold Screen, but this is not displayed for the interval function.</p> <p> "Screen" on page 97</p>
	Screen2	
	Screen3	
	Screen4	
	Lap Hold Screen	

*1 Displayed after registering the HR monitor.

*2 Only displayed for the SF-710/SF-510.

Settings

Allows you to change the settings for the device.

Changing the Settings

Operation buttons



- 1** Displays the **Settings** menu.
Hold down **B** on the time screen.

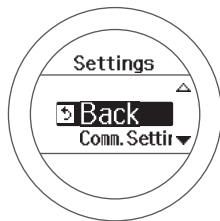

- 2** Select a setting item.
Use **C/D** to select, and then press **A**.

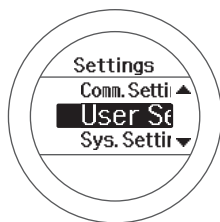

- 3** Select a setting item.
Use **C/D** to select, and then press **A**.

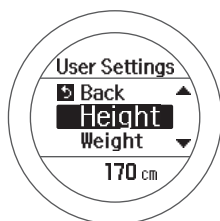

- 4** Select a setting value.
Use **C/D** to select, and then press **A**.

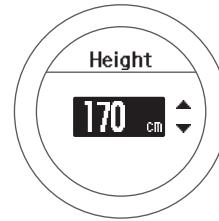

Depending on the setting item, you may need to make more settings after this. Follow the on-screen instructions.

Note:
When setting a number, hold down **C/D** to speed through the numbers.

- 5** This completes the settings.
Hold down **A**.
Displays the time screen.

Settings

Settings Table

Comm. Settings

Set to connect the HR monitor to this device and communicate.

Setting items	Value	Explanation
HR Monitor	Status	Register the HR monitor to this device.
	Register	 "Registering the HR Monitor to the Device" on page 68
Smartphone	Communicate	Register a smartphone to this device.
	Forget Device	See the "Smartphone User's Guide" for more details.

User Settings

Set the user information.

The Height, Weight, DOB, and Gender information is used to calculate the calories burnt.

The value in parenthesis () is the default setting.

Setting items	Value	Explanation
Height	(170 cm)	Set the height.
Weight	(60 kg)	Set the weight.
DOB Year	(1975)	Set your date of birth.
DOB Month	(1)	
DOB Day	(1)	
Gender	Male (default)	Set your gender.
	Female	
HR Zone	Zone1 (100 to 30 bpm)	Set the maximum and minimum heart rate.
	Zone2 (130 to 101 bpm)	You can set five zones to suit the exercise intensity.
	Zone3 (160 to 131 bpm)	
	Zone4 (190 to 161 bpm)	
	Zone5 (240 to 191 bpm)	

Settings

Sys. Settings

Make settings for the device's system.

The value in parenthesis () is the default setting.

Setting items	Value	Explanation
Language	English (default)	Set the display language.
	XXX	
Units	km (default)	Set the display units for distance.
	mile	
Clock	12 Hour (default)	Set the format for the display time.
	24 Hour	
DST	ON	Set summer time.
	OFF (default)	
Time Adjust	-	<p>The device receives a signal from the GPS and automatically sets the time.</p> <p>Signals from the GPS cannot be received while indoors. Make sure the screen is facing up and you are outside with no obstructions overhead.</p> <p>If GPS positioning is not complete after two minutes or Failed is displayed, we recommend selecting Cancel, moving to a different location, and trying again.</p>
Time Zone	Auto (default)	Sets the time zone for your location.
	Manual	<p>When Auto is selected, perform Time Adjust to set the time zone automatically.</p> <p>When Manual is selected, set the time zone within a range of -12:00 to +14:00.</p>
Date Format	Day. Month	Set the display format for the date.
	Month. Day (default)	
Invert Disp.	ON	Set the display format for the screen.
	OFF (default)	<p>When ON is selected, white text is displayed over a black background.</p> <p>When OFF is selected, black text is displayed over a white background.</p>
Contrast	(4)	Set the contrast for the screen.
Auto Sleep	ON (default)	When you are resting, this function automatically puts the device into sleep status.
	OFF	Entering sleep status reduces the amount of electricity being used.

Settings

Setting items	Value	Explanation
Auto Light	ON	When the screen changes, this function automatically turns on the light. When a specified time has passed, the light automatically turns off.
	OFF (default)	
Alarm	Tones (default)	Set the alarm type and time.
	Vib.*	
	Tones & Vib.*	
	OFF	
Operation Tones	ON (default)	Turn on or off the operation tones.
	OFF	
Initialize	-	Initialize all setting information (User Settings , Sys. Settings , and Mes. Settings) in the device's memory. History data is also deleted.
Software Version	-	Displays the firmware version information.

* Only displayed for the SF-710.

Settings

Screen

There are four measurement screens that can be displayed. You can change the screen pattern (change the screen display line 1, line 2, line 3, and so on) and the measurement items displayed for each screen.

You can also change the lap hold screen.

Note:

See the following pages for the default screen settings.

 ["Screen Display" on page 42](#)

Settings

Screen Settings

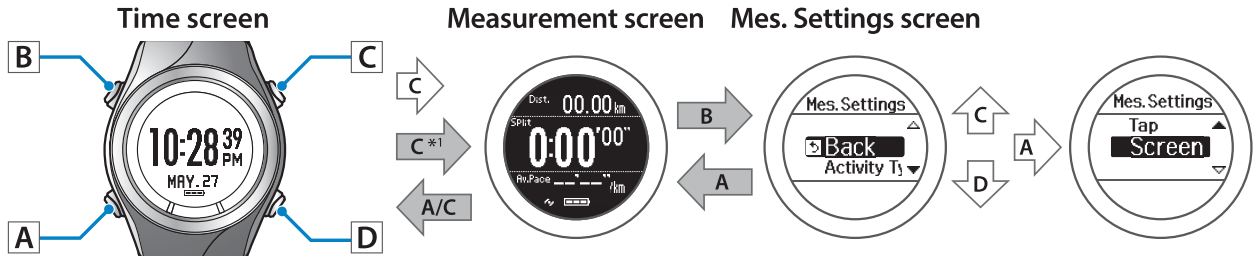
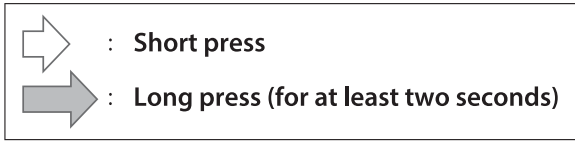

*1 : Indoor mode
SF-710/SF-510 only

Screen menu		
Screen	Screen Patt.	Item
Screen1 Screen2 Screen3 Screen4	1 Line 2 Lines 3 Lines	Distance Altitude Steps*2 Lap Distance Guide Time Lap Steps*2 Pace Guide Distance HR Zone Time*2 Average Pace Stride*2 Time to HR Zone*2 Lap Pace Average Stride*2 Total Ascent*3 Speed Lap Stride*2 Total Descent*3 Average Speed Pitch*2 Grade*3 Lap Speed Average Pitch*2 Latitude/Longitude*2 Split Time Lap Pitch*2 Estimated Time Lap Time HR Estimated Distance Time Average HR Calories Burnt Maximum HR*2 Lap HR
	Pace&Graph HR&Graph Lap Target Pace OFF	
Lap Hold Screen	1 Line 2 Lines	Split Time Lap Distance Lap Time Lap Pace Lap HR





*2 : SF-710/SF-510 only
*3 : SF-710 only

Hold down A to display the measurement screen.

Settings

Screen Pattern Table



Measurement screen

Screen Pattern	Screen	Explanation
1 Line		Displays one measurement item on the screen.
2 Lines	, LapDist. 0.000 km" data-bbox="338 332 475 429"/>	Displays two measurement items on the screen by dividing the screen into two sections.
3 Lines		Displays three measurement items on the screen by dividing the screen into three sections.
Pace&Graph	, Lap 5'30", and a bar graph" data-bbox="338 566 475 663"/>	When a pace alarm is set, this shows whether or not you have achieved the pace. When the pace alarm is off, only the current pace is displayed.
HR&Graph		When the HR alarm is set, this shows whether or not you are within the limits of the set heart rate zone. When the HR alarm is off, only the current heart rate is displayed.
Lap		Displays information on the lap acquired from the lap function.

Settings

Screen Pattern	Screen	Explanation
Target Pace		Displays the current pace at the top and the target pace at the bottom.
OFF	-	The measurement screen is not displayed.

Lap Hold Screen

Screen Pattern	Screen	Explanation
1 Line		Displays one measurement item on the screen.
2 Lines		Displays two measurement items on the screen by dividing the screen into two sections.

Settings

Measurement Display Items Table

Measurement screen

Display item	Display name		Explanation
	1 Line	2 Lines/3 Lines	
Distance	Distance	Dist.	Total distance from the start of measurements
Lap Distance	LapDistance	LapDist.	Distance for each lap
Pace	Pace	Pace	Current pace (time taken for one kilometer)
Average Pace	Avg.Pace	Av.Pace	Average pace from the start of measurements
Lap Pace	LapPace	LapPace	Average pace for each lap
Speed	Speed	Speed	Current speed
Average Speed	Avg.Speed	Av.Spnd	Average speed from the start of measurements
Lap Speed	LapSpeed	LapSpd	Average speed for each lap
Split Time	SplitTime	Split	Total time from the start of measurements
Lap Time	LapTime	Lap	Time for each lap
Time	Time	Time	Current time
Calories Burnt	Calories	Calories	Current calories burnt through exercise
Altitude* ¹	Altitude	Alt.	Current altitude
Guide Time* ²	GuideTime	Guide	Progress time towards target pace (reaching target or falling behind)
Guide Distance* ²	GuideDist.	GuideDist.	Progress distance towards target pace (reaching target or falling behind)
Stride* ³	Stride	Stride	Current Stride
Average Stride* ³	Avg.Stride	Av.Stride	Average stride from the start of measurements
Lap Stride* ³	LapStride	LapStride	Average stride for each lap
Pitch* ³	Pitch	Pitch	Current Pitch (number of strides in one minute)
Average Pitch* ³	Avg.Pitch	Av.Pitch	Average pitch from the start of measurements
Lap Pitch* ³	LapPitch	LapPitch	Average pitch for each lap
HR	HR	HR	Current heart rate
Average HR	Avg.HR	Av.HR	Average heart rate from the start of measurements
Maximum HR* ³	Max.HR	Max.HR	Maximum heart rate from the start of measurements
Lap HR	LapHR	LapHR	Average heart rate for each lap

Settings

Display item	Display name		Explanation
	1 Line	2 Lines/3 Lines	
Steps ^{*3}	Steps	Steps	Number of steps from the start of measurements
Lap Steps ^{*3}	LapSteps	LapStp	Number of steps for each lap
HR Zone Time ^{*3}	Spent.HR	Spent.HR	Time within heart rate zone for each lap
Time to HR Zone ^{*3}	Time.HR	Time.HR	Time until entering heart rate zone for each lap
Total Ascent ^{*1*4}	TotalAscent	Tot.Asc.	Total ascent from the start of measurements
Total Descent ^{*1*4}	TotalDescent	Tot.Des.	Total descent from the start of measurements
Grade ^{*1*4}	Grade	Grade	Current Grade
Latitude/Longitude ^{*1*3}	LAT/LONG	LAT/LONG	Current Latitude/Longitude
Estimated Time ^{*5}	Est.Time	Est.	Estimated time of arrival at the target time set in the goal function
Estimated Distance ^{*5}	Est.Distance	Est.Distance	Estimated time of arrival at the target distance set in the goal function

*1 **Altitude**, **Total Ascent**, **Total Descent**, and **Grade** are calculated using the GPS signal. There may be large errors in the position and distance depending on the GPS environment.

*2 Set the **Target Pace**.

 ["Setting a Pace and Measuring \(Target Pace Function\)"](#) on page 61

*3 Only displayed for the SF-710/SF-510.

*4 Only displayed for the SF-710.

*5 Use when **Mode** is set to **Goal** from the **Mes. Settings** menu.

Lap Hold Screen

Display item	Display name		Explanation
	1 Line	2 Lines/3 Lines	
Split Time	SplitTime	Split	Total time from the start of measurements
Lap Distance	LapDistance	LapDist.	Distance for each lap
Lap Time	LapTime	Lap	Time for each lap
Lap Pace	LapPace	LapPace	Average pace for each lap
Lap HR	LapHR	LapHR	Average heart rate for each lap

Changing the Measurement Screen

The setting method varies depending on the screen pattern. See the explanations for each screen pattern.

“Setting **1 Line/2 Lines/3 Lines**” on page 103

“Setting **Pace&Graph/HR&Graph**” on page 104

“Setting **Lap/Target Pace/OFF**” on page 106

Important:

- ❑ When performing GPS positioning, make sure the screen is facing up and you are outside with no obstructions overhead.

“Specifying a GPS (GPS Positioning)” on page 29

- ❑ It usually takes less than two minutes to complete GPS positioning.

If GPS positioning is not complete after two minutes or **Failed** is displayed, we recommend selecting **Cancel**, moving to a different location, and trying again.

Setting 1 Line/2 Lines/3 Lines

Here we will explain how to set **1 Line** to **Calories Burnt** in **Screen4**.

Operation buttons



- 1 Display the measurement screen.
Use one of the following methods to display.
 - ❑ When performing GPS positioning:
Press **C** on the time screen.
 - ❑ When skipping GPS positioning:

Press **C** on the time screen, and then select **Skip** on the GPS positioning screen.

“Skipping GPS positioning” on page 30

- ❑ When not performing GPS positioning (Indoor mode: SF-710/SF-510 only):

Press **C** on the time screen.

“Indoor mode (SF-710/SF-510 only)” on page 31



- 2 Displays the **Mes. Settings** menu.
Hold down **B** on the measurement screen.

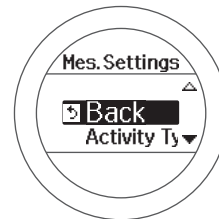

- 3 Select **Screen**.
Use **C/D** to select, and then press **A**.

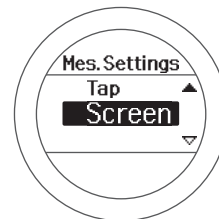

- 4 Select **Screen4**.
Use **C/D** to select, and then press **A**.

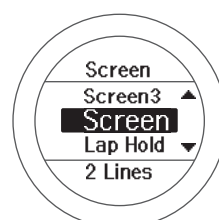

Settings

5 Select **1 Line**.

Use **C/D** to select, and then press **A**.

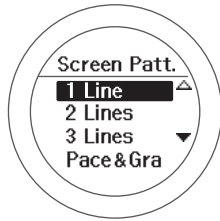

Screen Image is displayed. **Altitude** is displayed by default.

After checking, press **A** and go to the following step.

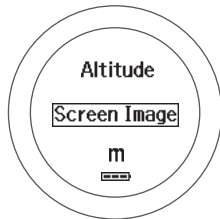

6 Select **Line 1**.

Use **C/D** to select, and then press **A**.

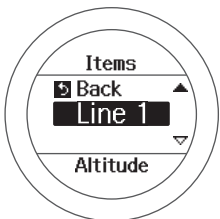

7 Select **Calories Burnt**.

Use **C/D** to select, and then press **A**.

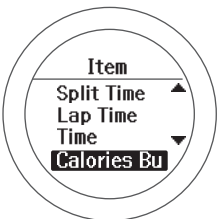

Screen Image is displayed.

After checking, press **A** and go to the following step.

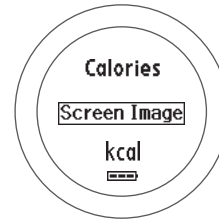

Note:
When you want to set **2 Lines** and **3 Lines**, repeats steps 6 and 7.

8 This completes the settings.

Hold down **A**.

The measurement screen is displayed.

Press **A** on the measurement screen to change the screen, and then check if **Screen4** has been changed.

Note:
Hold down **A** on the measurement screen to display the time screen.

Setting Pace&Graph/HR&Graph

Here we will explain how to set **Pace&Graph** in **Screen4**.

Operation buttons



1 Display the measurement screen.

Use one of the following methods to display.

- ❑ When performing GPS positioning:
Press **C** on the time screen.

Settings

- When skipping GPS positioning:

Press **C** on the time screen, and then select **Skip** on the GPS positioning screen.

“Skipping GPS positioning” on page 30

- When not performing GPS positioning (Indoor mode: SF-710/SF-510 only):

Press **C** on the time screen.

“Indoor mode (SF-710/SF-510 only)” on page 31



- Displays the **Mes. Settings** menu.

Hold down **B** on the measurement screen.

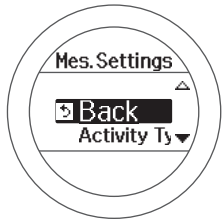

- Select **Screen**.

Use **C/D** to select, and then press **A**.

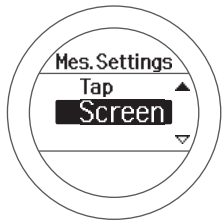

- Select **Screen4**.

Use **C/D** to select, and then press **A**.

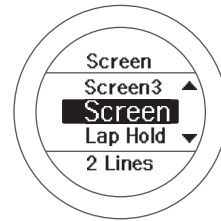

- Select **Pace&Graph**.

Use **C/D** to select, and then press **A**.

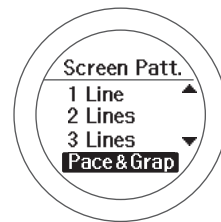

Screen Image is displayed.

After checking, press **A** and go to the following step.

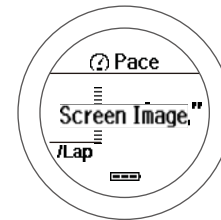

- Select the interval at which to display the screen.

Use **C/D** to select, and then press **A**.

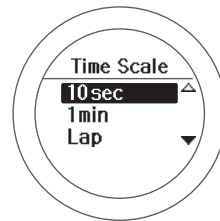

- This completes the settings.

Hold down **A**.

The measurement screen is displayed.

Settings

Press **A** on the measurement screen to change the screen, and then check if **Screen4** has been changed.

Note:

Hold down **A** on the measurement screen to display the time screen.

Setting Lap/Target Pace/OFF

Here we will explain how to set **Lap** in **Screen4**.



- 1 Display the measurement screen.
Use one of the following methods to display.
 - ❑ When performing GPS positioning:
Press **C** on the time screen.
 - ❑ When skipping GPS positioning:
Press **C** on the time screen, and then select **Skip** on the GPS positioning screen.
[“Skipping GPS positioning” on page 30](#)
 - ❑ When not performing GPS positioning (Indoor mode: SF-710/SF-510 only):
Press **C** on the time screen.
[“Indoor mode \(SF-710/SF-510 only\)” on page 31](#)



- 2 Displays the **Mes. Settings** menu.
Hold down **B** on the measurement screen.

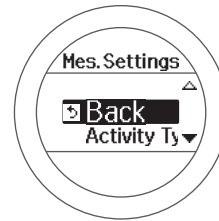

- 3 Select **Screen**.
Use **C/D** to select, and then press **A**.

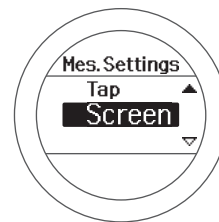

- 4 Select **Screen4**.
Use **C/D** to select, and then press **A**.

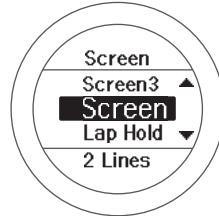

- 5 Select **Lap**.
Use **C/D** to select, and then press **A**.

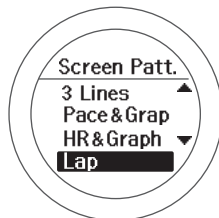

Screen Image is displayed.

Settings

After checking, press **A** and go to the following step.

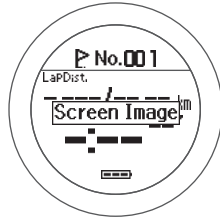

6 This completes the settings.

Hold down **A**.

The measurement screen is displayed.

Press **A** on the measurement screen to change the screen, and then check if **Screen4** has been changed.

Note:

Hold down A on the measurement screen to display the time screen.

Settings

Changing the Lap

Here we will explain how to set **Lap Pace** in **1 Line**.

Operation buttons



1 Display the measurement screen.

Use one of the following methods to display.

- ❑ When performing GPS positioning:
Press **C** on the time screen.
- ❑ When skipping GPS positioning:
Press **C** on the time screen, and then select **Skip** on the GPS positioning screen.

[🔗 “Skipping GPS positioning” on page 30](#)

- ❑ When not performing GPS positioning (Indoor mode: SF-710/SF-510 only):

Press **C** on the time screen.

[🔗 “Indoor mode \(SF-710/SF-510 only\)” on page 31](#)



2 Displays the **Mes. Settings** menu.

Hold down **B** on the measurement screen.

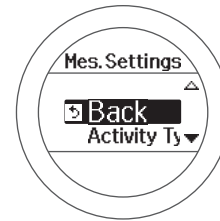

3 Select **Screen**.

Use **C/D** to select, and then press **A**.

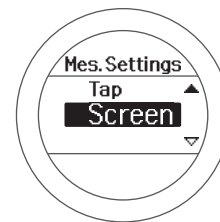

4 Select **Lap Hold Screen**.

Use **C/D** to select, and then press **A**.

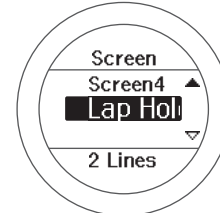

5 Select **1 Line**.

Use **C/D** to select, and then press **A**.

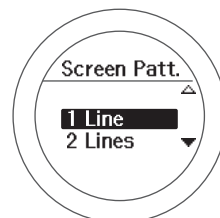

Screen Image is displayed. **Lap Distance** is displayed by default.

Settings

After checking, press **A** and go to the following step.

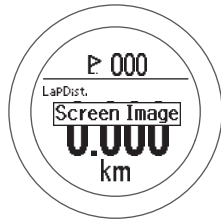

6 Select **Line 1**.

Use **C/D** to select, and then press **A**.

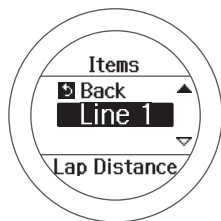

7 Select **Lap Pace**.

Use **C/D** to select, and then press **A**.

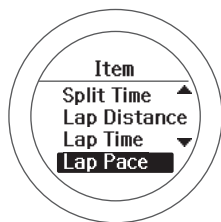

Screen Image is displayed.

After checking, press **A** and go to the following step.

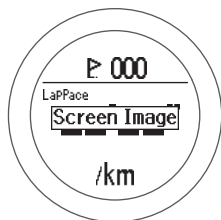

Note:

When you want to set **2 Lines**, repeats steps 6 and 7.

8 This completes the settings.

Hold down **A**.

The measurement screen is displayed.

Note:

Hold down **A** on the measurement screen to display the time screen.

Settings

Setting Examples

Here we will provide two usage examples.

Note:

See the following page for information on making changes.

 [“Changing the Measurement Screen” on page 103](#)

Default settings

Screen	Screen Pattern	Measurement item
Screen1		3 Lines Distance (Dist.) Split Time (Split) Average Pace (Av.Pace)

Recommended settings for a marathon

Display a large **Distance** and **Split Time** on one screen.

Screen	Screen Pattern	Measurement item
Screen1		2 Lines Distance (Dist.) Split Time (Split)

Recommended settings for walking

Display **Calories Burnt**, **Distance**, and **Time** on one screen.

Screen	Screen Pattern	Measurement item
Screen1		3 Lines Calories Burnt (Calories) Distance (Dist.) Time (Time)

Maintenance

This section explains how to maintain this device, replace the battery, and update the firmware.

 ["Performing Maintenance" on page 112](#)

 ["Replacing the Battery" on page 114](#)

 ["Updating the Firmware" on page 115](#)

Performing Maintenance

Performing After Care



Important:

- ❑ If the device is placed in the cradle when it is covered in water, sweat, or dirt, the contact points could corrode, malfunction, or cause a communication failure.
- ❑ Do not perform button operations when it is wet. Otherwise a malfunction could occur.

After using the device, use a little clean water to wash the contact points, wipe away most of the water with a towel and so on, and then let it dry naturally. Water, sweat, or dirt could cause the device to malfunction.



If charging or communicating becomes unstable, clean the contact points on the device and the cradle with a damp cotton swab.

Do not clean using organic solvents such as benzene, thinner, alcohol, or detergent. This could cause the product to degrade.

About the strap

If the strap gets soiled, wash it with water and wipe thoroughly with a dry cloth. This strap is made from polyurethane and after years of use the color may fade or it may lose its elasticity.

HR Monitor Maintenance

- ❑ After exercising, take off the HR monitor and HR belt, dip them in water and wash.
- ❑ Also make sure that you wash the button sections and wipe off all moisture.
- ❑ Although you can wash the HR belt in a washing machine, make sure you place the belt in a net, and do not use a drier.
- ❑ Do not iron, dry clean, or use a chlorine-based detergent on the HR belt.
- ❑ Wash the HR monitor carefully with water. Do not use a washing machine or a drier.

Maintenance

- ❑ Dry the HR monitor and HR belt completely and store them separately.

Replacing the Battery

About the Device's Rechargeable Battery

You cannot replace the built-in rechargeable battery yourself.

After prolonged use, the battery may not retain its charge for as long as it used to. In this situation, contact your local dealer or our repair center to replace the battery. You will need to pay for the battery to be replaced.

The average service life for the battery is five years, although this may change depending on the operating conditions.

About the HR Monitor Battery

Be careful not to injure yourself when replacing the HR monitor battery (CR2032).

 [“Replacing the Battery for the HR Monitor” on page 74](#)

The average service life for the battery when using the HR monitor for one hour every day is one and a half years.

Updating the Firmware

You may be able to resolve problems that occur by updating the firmware.

We recommend downloading and using the latest version.



Important:

When updating the firmware, the history may be deleted and settings may be initialized. See the updating explanation for more details. Before updating the firmware, we recommend uploading your measurement data to NeoRun.

“Creating an Account (When Using for the First Time)” on page 80

Checking the Firmware Version

Operation buttons



1

Displays the Settings menu.

Hold down **B** on the time screen.

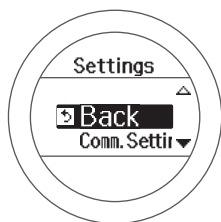

2

Select **Sys. Settings**.

Use **C/D** to select, and then press **A**.

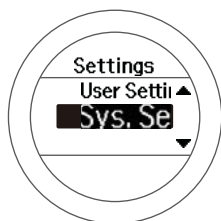

3

Select **Software Version**.

Use **C/D** to select, and then press **A**.

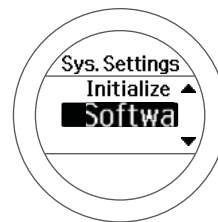

4

Check the version.



5

Close the settings.

Hold down **A**.

Displays the time screen.

Updating the Firmware

Download "WristableGPS" from the following Epson Web site and update the firmware.





<http://www.epson.jp/download/>

Note:

See the download page on the Epson Web site for details on how to update the firmware.

Troubleshooting

This section explains how to solve problems that occur during use.

-  **"Caution:" on page 117**
-  **"Problem Solving" on page 118**
-  **"Resetting the System" on page 121**
-  **"Contacting us About this Product" on page 122**
-  **"After Service" on page 123**

Troubleshooting

Caution:

- ❑ After using the device, use a little clean water to wash the contact points, wipe away most of the water with a towel and so on, and then let it dry naturally. If the device is placed in the cradle when it is dirty, it could corrode, malfunction, or cause a communication failure.
- ❑ If charging or communicating becomes unstable, clean the contact points on the device and the cradle with a damp cotton swab.
- ❑ If device operations become unstable or if functions do not operate correctly, perform a system reset (hold down all four buttons at the same time).
- ❑ If the HR monitor operations become unstable or if it does not function correctly, remove the HR monitor battery, turn it over so that the negative side is facing up, and then replace it for three seconds (reset).







Troubleshooting

Problem Solving



Check each item.

Problem		Solution
Basic actions	The screen is not displayed.	Operation stops immediately after purchase. Charge before use. Also, nothing is displayed if the battery runs out. Charge the battery. 🔗 "Charging" on page 22
	The device does not react even after performing an operation.	Is the battery running low? Charge the battery. 🔗 "About the Battery" on page 28 If the device does not operate after charging, try resetting the system. 🔗 "Resetting the System" on page 121
	The screen turns off or turns blue during use	Perform a system reset. 🔗 "Resetting the System" on page 121
	The clock turns off.	When you are resting, the device enters sleep status and the time is displayed. This does not indicate a problem as the display is restored the next time you move. If the display is not restored, the battery is running low. Charge the battery. 🔗 "Charging" on page 22 Also, if Auto Sleep is turned off, the clock does not disappear. 🔗 "Sys. Settings" on page 95
	The time is not set correctly.	Set "Time Adjust" from Sys. Settings. 🔗 "Sys. Settings" on page 95 If the hour is different, check the time zone and summer time settings. 🔗 "Sys. Settings" on page 95
	Measurement stops while exercising.	When exercising slowly, such as when walking, we recommend turning off the AT Pause function. 🔗 "Automatically Start/Stop Measuring (AT Pause Function)" on page 59
Chronograph actions	The device cannot receive a GPS signal.	Go to a location outside with no obstructions overhead. Signals from the GPS cannot be received while indoors. Also, if there are any obstacles partially blocking the sky, such as tall buildings and mountain sides, reception may be interrupted causing a lack of precision.
	Signals from the GPS are hard to receive or are interrupted.	Even when a signal is being received, it may be interrupted depending on the running environment. Wear on the outside of your arm. Also, make sure the strap is tightened.

Troubleshooting

Problem		Solution
Charging	The device does not charge even when it is placed in the cradle. Charging stops frequently.	<p>Check the connection for the cradle.</p> <p>Clean the contact points on the device and the cradle.</p> <p> "Performing After Care" on page 112</p> <p>A malfunction may have occurred if you cannot charge the device even after checking the points above. Stop charging the device, and contact our information center.</p>
	The charge error screen is displayed.	Charge in an environment where the surrounding temperature is 5 to 35°C.
	The device and the cradle become hot while charging.	There may be a malfunction. Stop using the device, and contact our information center.
Waterproofing function	Can I use the device when swimming?	This device is water resistant at 5 barometric pressures and can be used when swimming. Do not perform button operations in the water. GPS signals cannot be received when in water. Also, do not swim while wearing the optional HR monitor as it is not waterproof.
	Inside the glass becomes cloudy.	<p>Condensation may occur in the device due to differences in temperature between the device and the open air. Temporary condensation does not have any effect on the device. You can continue to use the device in this condition. If the condensation remains for a long time, water may have got inside the device.</p> <p>Contact our information center.</p>
Accessories	Acquiring optional products.	<p>The AC adapter and HR monitor are available as optional extras. Contact your local dealer for more information.</p> <p>Also, if you need an extra cradle, contact your local dealer or our information center.</p>
HR Monitor	The HR monitor is not working correctly.	<p>Check the following items.</p> <ul style="list-style-type: none"> <input type="checkbox"/> Are you wearing the HR belt correctly?  "Wearing the HR Monitor" on page 67 <input type="checkbox"/> Has it been registered to the device?  "Registering the HR Monitor to the Device" on page 68 <input type="checkbox"/> Is the HR monitor set to ON.  "Enabling the HR Monitor" on page 70 <input type="checkbox"/> If you cannot register to the device, replace the battery after resetting the HR monitor. To reset the HR monitor, turn the battery over so that the negative side is facing up and replace it for three seconds. <input type="checkbox"/> Has the battery run out? Replace the battery if it has run out.  "Replacing the Battery for the HR Monitor" on page 74 <input type="checkbox"/> Perform a system reset for the device.  "Resetting the System" on page 121

Troubleshooting

Problem		Solution
Communication	The device is not recognized correctly when it is connected to a computer.	<p>Check the connection for the computer and the cradle. Clean the contact points on the device and the cradle.</p> <p> "Performing After Care" on page 112</p> <p>Perform a system reset.</p> <p> "Resetting the System" on page 121</p>
Web application	When communicating with a computer, an error screen is displayed and communication stops.	<p>Do not move the device or the cradle during communication. Avoid communicating data under environments where static electricity has been generated. If an error occurs, reconnect the cradle to start communication again.</p>

* If you cannot solve the problem even after trying the points above, contact our information center.

Resetting the System

If operations are unstable, try resetting the system.

Hold down all of the buttons (A/B/C/D).

The screen is reset and the device restarts.

Initialize the device after restarting.

 [“Initializing” on page 26](#)

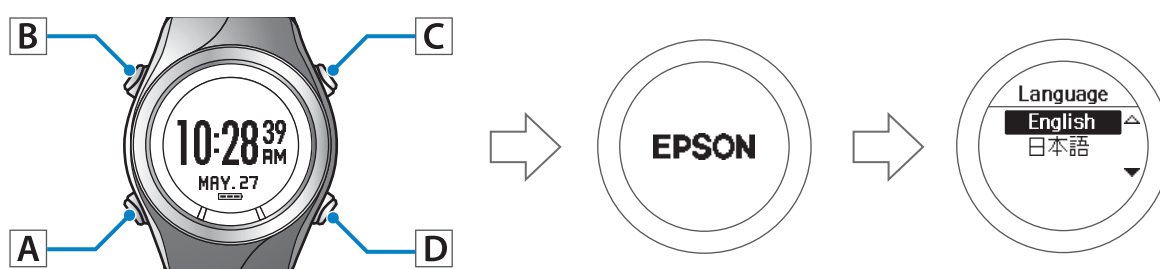

Important:

Measurement data is not recorded if a system reset is performed while measuring.

Note:

- Setting data and measurement data remains the same as before the reset was performed.
- The following shows the differences between a system reset and initializing. The time needs to be set again for both operations.

*System reset: The **User Settings**, **Sys. Settings**, **Mes. Settings**, history, stride, HR monitor, and smartphone registration information all remain as they were before the reset was performed.*

*Initialize: The **User Settings**, **Sys. Settings**, **Mes. Settings**, history, stride, HR monitor, and smartphone registration information are all initialized.*

Troubleshooting

Contacting us About this Product

- **インフォメーションセンター** 製品に関するご質問・ご相談に電話でお答えします。
【電話番号】 **050-3155-8280**
*上記電話番号をご利用できない場合は、042-585-8590 へお問い合わせください。
*記載の内容は予告無く変更になる場合がございます。
受付時間等、最新の情報はエプソンのホームページをご確認ください。<http://www.epson.jp/support/>

- **修理品送付・持ち込み依頼先**
お買い上げの販売店様へお持ち込みいただくか、下記修理センターまで送付願います。
松本修理センター
【所在地】 〒390-1243 松本市神林1563 エプソンサービス(株)
【電話番号】 **050-3155-7110**
*上記電話番号をご利用できない場合は、松本修理センター:0263-86-7660へお問い合わせください。
*記載の内容は予告無く変更になる場合がございます。
受付時間等、修理について最新の情報は、エプソンのホームページでご確認ください。<http://www.epson.jp/support/>

- **引取修理サービス(ドアto ドアサービス)に関するお問い合わせ**
引取修理サービス(ドアto ドアサービス)とはお客様のご希望日に、ご指定の場所へ、指定業者が修理品をお引取りにお伺いし、修理完了後弊社からご自宅へお届けする有償サービスです。*梱包は業者が行います。
【電話番号】 **050-3155-7150**
上記電話番号をご利用できない場合は、0263-86-9995 へお問い合わせください。
*記載の内容は予告無く変更になる場合がございます。
受付時間等、引取修理サービス(ドアto ドアサービス)について最新の情報は、エプソンのホームページでご確認ください。<http://www.epson.jp/support/>

- **ショールーム** *詳細はホームページでもご確認いただけます。<http://www.epson.jp/showroom/>
エプソンスクエア新宿 〒160-8324 東京都新宿区西新宿6-24-1 西新宿三井ビル1F

- **オプション品・消耗品ご購入**
お近くのエプソン商品取扱店及びエプソンダイレクト(ホームページアドレス <http://www.epson.jp/shop/> または通話料無料0120-545-101)でお買い求めください。(2012年5月現在)

WGPS 2013.11

Troubleshooting

After Service

- ❑ For repair and maintenance of this product, contact your local dealer or our repair center.
- ❑ After prolonged use, the battery may not retain its charge for as long as it used to. In this situation, contact your local dealer or our repair center to replace the battery. You will need to pay for the battery to be replaced.
- ❑ The strap for the device, the battery for the HR monitor, the HR belt, and the USB cable are not covered by the guarantee. If you need to purchase any of these items, contact your local dealer or our information center.
- ❑ Spare parts for repairing this product will be available for six years after the device has stopped being manufactured.
- ❑ In the event of product failure, we do not guarantee that data recorded on the device can be recovered.
- ❑ A sticker displaying the serial number for this product is stuck to the guarantee. If there is no sticker, the guarantee is void.

Appendix













 ["Understanding the Icons" on page 125](#)

 ["Product Specifications" on page 126](#)

 ["Glossary" on page 129](#)

Appendix

Understanding the Icons

Icon	Name
	Run mode (measuring while running)
	Walking mode (measuring while walking)
	Bike mode (measuring while riding a bike)
	The signal is being received from the GPS (GPS On)
	GPS positioning
	Communicating with the HR monitor
	Average pace
	Lap
	Distance
	Calories Burnt
	Split time
	Data that can be edited on the device
	Current setting

Appendix

Product Specifications

Device Specifications

Specifications		SF-710	SF-510	SF-310
Size (thickness)		13.6 mm	11.8 mm	12.8 mm
Weight		59g	49g	50g
Waterproofing function		5 atm		
Operating time	GPS On	30 hours		
	Time display (when Auto Sleep is On)	20 days		
Operating temperature		-5 to 50°C		
Possible memory time		Approx. 70 hours		
Maximum number of laps (one split)		400		
Heart rate measurement (using the HR monitor)		○*	○*	○*
Pitch/stride measurement		○	○	-
Indoor mode		○	○	-

Appendix

Specifications		SF-710	SF-510	SF-310
Display range	Distance/Lap Distance/Estimated Distance	0.000 to 999.99 km/0.000 to 999.99 mi		
	Pace/Lap pace/Average pace	0'00" to 30'00"/km/0'00" to 45'00"/mi		
	Speed/Lap Speed/Average Speed	0.0 to 999.9 km/h/0.0 to 999.9 mi/h		
	Split/Lap time	00'00" to 99:59'59"		
	Pitch/Lap Pitch/Average Pitch	0 to 255 spm		-
	Stride/Lap Stride/Average Stride	0 to 255 cm/0 to 100 inch		-
	Steps/Lap Steps	0 to 999999		-
	Calories Burnt	0 to 9999 kcal		
	Grade	-99 to 99%	-	-
	Altitude	-500 to 9,999m/-1500 to 914,369.52cm		
	Total Ascent	0 to 99999 m/ 0 to 99999 ft	-	-
	Total Descent	0 to 99999 m/ 0 to 99999 ft	-	-
	HR/Lap HR/Average HR/Maximum HR	1 to 255 bpm		
	Guide Time Range	0:00'00" to 9:59'59"		
Guide Distance Range	00.00 to 99.99 km/00.00 to 99.99 ml			

* The HR monitor can be purchased as an optional item.

Cradle specifications

Specifications	SF-710	SF-510	SF-310
Operating temperature range	5 to 35°C		

Option Specifications

The following products are available as optional extras. Contact your local dealer for more information.

AC adapter specifications

Specifications	Model No.: SFAC01
Power	AC 100V 50/60 Hz shared
Output voltage/Output current	DC 5V/1.0A

Appendix**HR monitor specifications**

Specifications	Model No.: SFHRM01
Waterproofing function	Water resistant for daily use

Glossary

	Term	Definition
	AT Lap	This automatically records laps when you have run for a fixed amount of time or a fixed distance.
	AT Light	This automatically turns on the light during lap measuring, alarm notification, and during the interval function.
	AT Pause	Automatically stops measuring when you stop exercising, and resumes when you continue.
	Chronograph	This function allows you to measure split times and lap times (section measurement) simultaneously.
	Distance	Distance from the measurement start point to the current time.
	GPS function	A system that receives signals in a GPS receiver from satellites orbiting the earth and calculates your current position. This function allows you to accurately understand positional and time information.
	Guide distance	This calculates if you are reaching or falling behind the target pace distance.
	HR Zone Time	The time you have remained with the heart rate zone.
	Lap pace	Your pace for the current lap.
	Lap Pitch	Your average pitch per lap.

Appendix

	Term	Definition
Lap Speed	Your average speed per lap.	
Lap time	Your time for the lap.	
NeoRun	WristableGPS dedicated Web application. This allows you to manage your course, analyze your pace, check calories burnt, and check your condition.	
Pace	Your current pace acquired from GPS information.	
Pitch	Measures the number of steps taken in one minute.	
Split time	The time from starting measurements to stopping measurements.	
Stride	The stride calculated from your running data.	
Stride sensor	This uses the GPS function to accumulate data on your stride and acceleration allowing the device to calculate the distance traveled even when you enter locations that cannot receive GPS signals.	
Time to HR Zone	The time until you arrive at the heart rate zone.	
Total Ascent	The total value of the height ascended from the measurement start point.	
Total Descent	The total value of the height descended from the measurement start point.	

Appendix

	Term	Definition	
XXX	Water resistant at 5 barometric pressures	The device is water resistant at up to 5 barometric pressures.	
	XXX	Interval	This training allows you to perform sets of hard (sprint) and light (rest) exercise over a specified time or distance, and repeat the set.
XXX		XXX	Guide time
			Calculating calories burnt
	XXX		XXX

Index

Index**A**

AC adapter.....	14
Altitude.....	35, 101
AT Lap.....	57
AT Pause.....	59
Average HR.....	36, 37, 72, 101
Average Pace.....	35, 101
Average Pitch.....	36, 101
Average Speed.....	35, 101
Average Stride.....	35, 101

C

Calories Burnt.....	35, 101
Chronograph.....	39
Cradle.....	14

D

Distance.....	35, 101
---------------	---------

E

Estimated Distance.....	36, 102
Estimated Time.....	36, 102

G

GPS positioning.....	29
Grade.....	36, 102
Guide Distance.....	35, 101
Guide Time.....	35, 101

H

Heart rate.....	66
HR.....	36, 37, 72, 101
HR belt.....	14
HR Monitor.....	70
HR monitor.....	14, 67
HR Zone Time.....	36, 37, 73, 102

I

Icons.....	125
Interval.....	44

L

Lap Distance.....	35, 101, 102
Lap HR.....	36, 37, 73, 101, 102
Lap Pace.....	35, 101, 102

Lap Pitch.....	36, 101
Lap Speed.....	35, 101
Lap Steps.....	36, 102
Lap Stride.....	35, 101
Lap Time.....	35, 39, 101, 102
Latitude/Longitude.....	36, 102

M

Maximum HR.....	36, 37, 72, 101
Measurement items.....	36, 37

N

NeoRun.....	82
NR Uploader.....	79

P

Pace.....	35, 101
Pitch.....	36, 101

R

Repeat no.....	44
Rest.....	44

S

Speed.....	35, 101
Split Time.....	35, 39, 101, 102
Sprint.....	44
Steps.....	36, 102
Stride.....	35, 101
Stride sensor.....	33
System reset.....	121

T

Target Pace.....	61
Time.....	35, 101
Time to HR Zone.....	36, 37, 73, 102
Total Ascent.....	36, 102
Total Descent.....	36, 102

EPSON

GPS Sports Monitor

WristableGPS

SF-710 | SF-510 | SF-310

<http://www.epson.jp/support/>



412644000

©2013 Seiko Epson Corporation. All rights reserved.



Certification information



GPS Sports Monitor
Model: SF-710, SF-510, SF-310

FCC ID : BKMAP003

CAN ICES-3 (B) /NMB-3 (B)
IC : 1052F-AP-003

FCC /IC Notices

This transmitter must not be co-located or operated in conjunction with any other antenna or transmitter.

This device complies with Part 15 of FCC Rules and Industry Canada licence-exempt RSS standard(s). Operation is subject to the following two conditions: (1) this device may not cause interference, and (2) this device must accept any interference, including interference that may cause undesired operation of this device.

Le présent appareil est conforme aux la partie 15 des règles de la FCC et CNR d'Industrie Canada applicables aux appareils radio exempts de licence. L'exploitation est autorisée aux deux conditions suivantes : (1) l'appareil ne doit pas produire de brouillage, et (2) l'utilisateur de l'appareil doit accepter tout brouillage radioélectrique subi, même si le brouillage est susceptible d'en compromettre le fonctionnement.

Caution:

Changes or modifications not expressly approved by the party responsible for compliance could void the user's authority to operate the equipment.

****Explanation that an SAR examination is unnecessary with Portable equipment****

This equipment complies with FCC/IC radiation exposure limits set forth for an uncontrolled environment and meets the FCC radio frequency (RF) Exposure Guidelines and RSS-102 of the IC radio frequency (RF) Exposure rules. This equipment has very low levels of RF energy that are deemed to comply without testing of specific absorption ratio (SAR).

Cet équipement est conforme aux limites d'exposition aux rayonnements énoncées pour un environnement non contrôlé et respecte les règles des radioélectriques (RF) de la FCC lignes directrices d'exposition et d'exposition aux fréquences radioélectriques (RF) CNR-102 de l'IC. Cet équipement émet une énergie RF très faible qui est considérée conforme sans évaluation du débit d'absorption spécifique (DAS).

****Explanation of the EMC demand part of the United States. ****

Note: This equipment has been tested and found to comply with the limits for a Class B digital device, pursuant to part 15 of the FCC Rules. These limits are designed to provide reasonable protection against harmful interference in a residential installation. This equipment generates, uses and can radiate radio frequency energy and, if not installed and used in accordance with the instructions, may cause harmful interference to radio communications. However, there is no guarantee that interference will not occur in a particular installation. If this equipment does cause harmful interference to radio or television reception, which can be determined by turning the equipment off and on, the user is encouraged to try to correct the interference by one or more of the following measures:

- Reorient or relocate the receiving antenna.
- Increase the separation between the equipment and receiver.
- Connect the equipment into an outlet on a circuit different from that to which the receiver is connected.
- Consult the dealer or an experienced radio/TV technician for help.

Epson America, Inc.

3840 Kilroy Airport Way Long Beach, CA 90806 U.S.A

Tel : 562-290-5254