

Proof Sign-off:
<antname> _____
<leadname> _____
<editname> _____

Paprika-U
Rev. B

A5 size
5/25/98

FRONT.FM
Pass 0

R

EPSON® GT-7000

GT-7000 PHOTO

Color Image Scanner

All rights reserved. No part of this publication may be reproduced, stored in a retrieval system, or transmitted in any form or by any means, electronic, mechanical, photocopying, recording, or otherwise, without the prior written permission of SEIKO EPSON CORPORATION. No patent liability is assumed with respect to the use of the information contained herein. Neither is any liability assumed for damages resulting from the use of the information contained herein.

Neither SEIKO EPSON CORPORATION nor its affiliates shall be liable to the purchaser of this product or third parties for damages, losses, costs, or expenses incurred by purchaser or third parties as a result of: accident, misuse, or abuse of this product or unauthorized modifications, repairs, or alterations to this product.

SEIKO EPSON CORPORATION and its affiliates shall not be liable against any damages or problems arising from the use of any options or any consumable products other than those designated as Original EPSON Products or EPSON Approved Products by SEIKO EPSON CORPORATION.

EPSON is a registered trademark of SEIKO EPSON CORPORATION.
IBM and PS/2 are registered trademarks of International Business Machines Corporation.
Macintosh is a registered trademark of Apple Computer, Inc.
Microsoft and Windows are registered trademarks of Microsoft Corporation in the United States of America and other countries.

General Notice: Other product names used herein are for identification purposes only and may be trademarks of their respective companies.

Copyright © 1998 by SEIKO EPSON CORPORATION, Nagano, Japan.



Printed on Recycled Paper.

User's Guide

FCC Compliance Statement For United States Users

This equipment has been tested and found to comply with the limits for a Class B digital device, pursuant to Part 15 of the FCC Rules. These limits are designed to provide reasonable protection against harmful interference in a residential installation. This equipment generates, uses, and can radiate radio frequency energy and, if not installed and used in accordance with the instructions, may cause harmful interference to radio or television reception. However, there is no guarantee that interference will not occur in a particular installation. If this equipment does cause interference to radio and television reception, which can be determined by turning the equipment off and on, the user is encouraged to try to correct the interference by one or more of the following measures.

- ▶ Reorient or relocate the receiving antenna.
- ▶ Increase the separation between the equipment and receiver.
- ▶ Connect the equipment into an outlet on a circuit different from that to which the receiver is connected.
- ▶ Consult the dealer or an experienced radio/TV technician for help.

WARNING

The connection of a non-shielded equipment interface cable to this equipment will invalidate the FCC Certification of this device and may cause interference levels which exceed the limits established by the FCC for this equipment. It is the responsibility of the user to obtain and use a shielded equipment interface cable with this device. If this equipment has more than one interface connector, do not leave cables connected to unused interfaces. Changes or modifications not expressly approved by the manufacturer could void the user's authority to operate the equipment.

For Canadian Users

This Class B digital apparatus complies with Canadian ICES-003.

Cet appareil numérique de la classe B est conforme à la norme NMB-003 du Canada.

Proof Sign-off: _____
<tantname> _____
<leadname> _____
<editname> _____

Paprika-U
Rev. B

A5 size
5/26/98

PAPR-U.TOC
Pass 0

R

Contents

Introduction

Features	1
Options	2
Warnings, Cautions, and Notes	2
Important Safety Instructions	3
ENERGY STAR Compliance	4
For United Kingdom Users	5
Safety information	5

Chapter 1 Setting Up the Scanner

Unpacking the Scanner	1-2
Scanner Parts	1-3
Choosing a Place for the Scanner	1-4
Installing a SCSI Interface Board (Windows Only)	1-6
Releasing the Transportation Lock	1-7
Plugging in the Scanner	1-8
Initialization	1-9
Connecting the Scanner to Your Computer	1-10
Understanding SCSI connections	1-10
Setting the SCSI ID number	1-12
Setting the terminator switch	1-14
Connecting the scanner	1-15
Power-on sequence	1-17
Power-off sequence	1-18

Proof Sign-off:
<antoname> _____
<leadername> _____
<editorname> _____

Paprika-U
Rev. B

A5 size
5/26/98

PAPR-U.TOC
Pass 0

R

Problems and Solutions	4-9
Error indicators	4-9
Operating problems	4-10
Quality problems	4-12
Clearing Jammed Paper	4-16

Appendix A Technical Specifications

Scanning	A-2
Electrical	A-4
Environmental	A-4
Safety Approvals	A-5
CE marking	A-5
SCSI Interface	A-6
Initialization Methods	A-7

Appendix B Contacting Customer Support

For United Kingdom and the Republic of Ireland Users	B-3
For Australian Users	B-5
For Singapore Users	B-6
For Hong Kong Users	B-7
For Philippines Users	B-8

Glossary

Index

Introduction

Features

The EPSON GT-7000/7000 PHOTO scanner offers the following features:

- Maximum optical resolution of 600 dots per inch (dpi) for main scanning, and 1200 dpi for sub scanning (36-bit for input, 24-bit for output) graphics scanner.
- Start Button control for shortcut scanning operation.
- Small and light body with A4/Letter size scanning area.
- Full color or grayscale scanning. Capture your images with 256 colors, or over 16 million colors; or up to 256 shades of gray.
- The EPSON Scan! II scanner utility and EPSON TWAIN let you take full advantage of your scanner's advanced features.
- Auto Area Segmentation (AAS) allows you to separate text from photographs on a page so that grayscale images are clearer and text recognition is more accurate.
- Text Enhancement Technology (TET) enhances text recognition accuracy when using your scanner for optical character recognition (OCR) scanning.
- EPSON TWAIN's "Best & de-screening" option automatically removes unwanted moiré patterns from scanned images for higher quality output.
- The GT-7000 PHOTO includes the Film Adapter which enables negative film and color slide film to be scanned. The Film Adapter is available as an option for GT-7000.

Proof Sign-off:
<stantoname> _____
<leadername> _____
<editorname> _____

Paprika-U
Rev. B

A5 size
5/26/98

INTRO.FM
Pass 0

R

Important Safety Instructions

Read all these instructions and save them for later reference.
Follow all warnings and instructions marked on the scanner.

- Unplug the scanner before cleaning. Clean with a damp cloth only. Do not spill liquid on the scanner.
- Do not place the scanner on an unstable surface or near a radiator or heat source.
- Do not block or cover the openings in the scanner's cabinet. Do not insert objects through the slots.
- Use only the type of power source indicated on the scanner's label.
- Connect all equipment to properly grounded power outlets. Avoid using outlets on the same circuit as photocopiers or air control systems that regularly switch on and off.
- Do not let the power cord become damaged or frayed.
- If you use an extension cord with the scanner, make sure the total ampere rating of the devices plugged into the extension cord does not exceed the cord's ampere rating. Also, make sure the total ampere rating of all devices plugged into the wall outlet does not exceed the wall outlet's ampere rating.
- Except as specifically explained in this *User's Guide*, do not attempt to service the scanner yourself.
- Unplug the scanner and refer servicing to qualified service personnel under the following conditions:

If the power cord or plug is damaged; if liquid has entered the scanner; if the scanner has been dropped or the cabinet damaged; if the scanner does not operate normally or exhibits a distinct change in performance. Adjust only those controls that are covered by the operating instructions.

Proof Sign-off:
<antname> _____
<leadname> _____
<editname> _____

Paprika-U
Rev. B

A5 size
5/26/98

INTRO.FM
Pass 0

R

For United Kingdom Users

Safety information



Warning: *This appliance must be earthed. Refer to the rating plate for voltage and check that the appliance voltage corresponds to the supply voltage.*

Important: *The wires in the mains lead fitted to this appliance are coloured in accordance with the following code:*

*Green and yellow — Earth
Blue — Neutral
Brown — Live*

As the colours of the wires in the mains lead of this appliance may not correspond with the coloured markings identifying the terminals in your plug, proceed as follows:

The green and yellow wire must be connected to the terminal in the plug which is marked with the letter E or with the earth symbol (\perp).

The blue wire must be connected to the terminal in the plug marked with the letter N.

The brown wire must be connected to the terminal in the plug marked with the letter L.

If damage occurs to the plug, replace the cord set or consult a qualified electrician.

Replace fuses only with a fuse of the correct size and rating.

Chapter 1

Setting Up the Scanner

1

Unpacking the Scanner	1-2
Scanner Parts	1-3
Choosing a Place for the Scanner	1-4
Installing a SCSI Interface Board (Windows Only)	1-6
Releasing the Transportation Lock	1-7
Plugging in the Scanner	1-8
Initialization	1-9
Connecting the Scanner to Your Computer	1-10
Understanding SCSI connections	1-10
Setting the SCSI ID number	1-12
Setting the terminator switch	1-14
Connecting the scanner	1-15
Power-on sequence	1-17
Power-off sequence	1-18

Scanner Parts

1

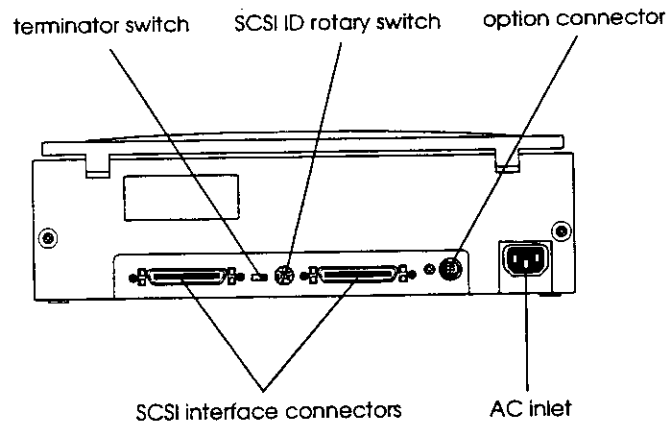
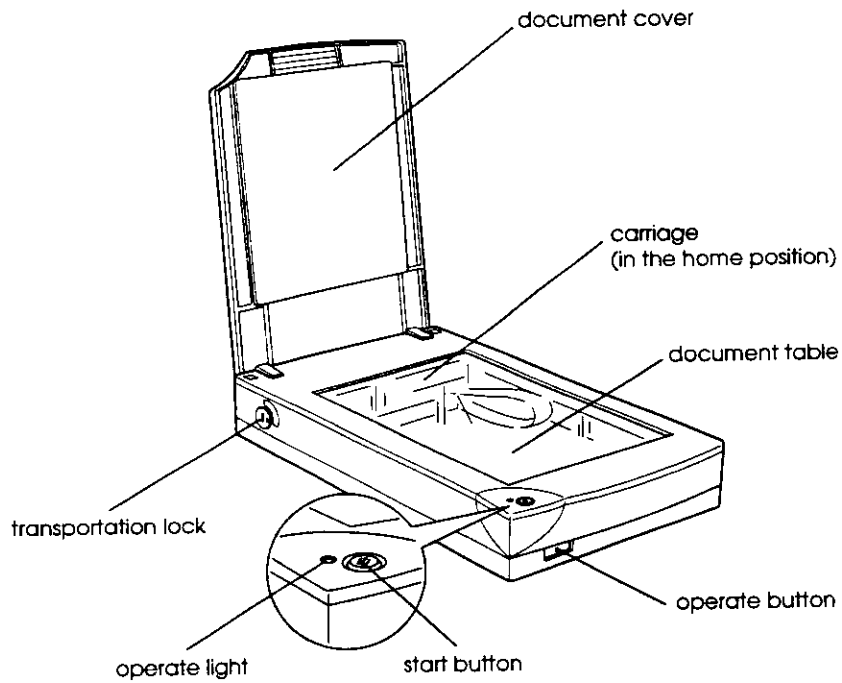

Proof Sign-off:
M. Fujimori
<leadername>
<editorname>

Paprika-U Rev. B

A5 size
5/26/98

CHAP1.FM
Pass 0

R

1

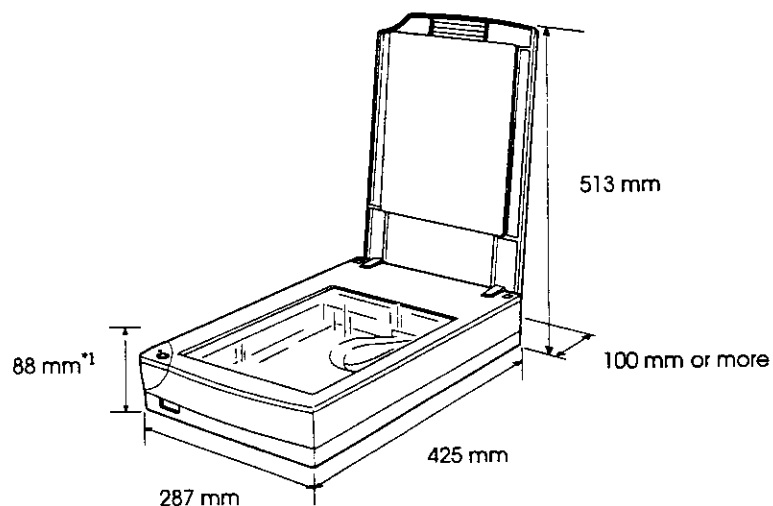

*1 When document cover is closed.

- Keep the scanner away from high temperatures, humidity and excessive dirt or dust. Also avoid using or storing the scanner in places subject to rapid changes of temperature and humidity.
- Keep the scanner away from direct sunlight and strong light sources.
- Avoid places subject to shocks and vibrations.

Releasing the Transportation Lock

1

Before connecting the scanner to a power source, you must release the transportation lock.

1. Place the scanner on a flat, stable surface with the front facing you.
2. Turn the transportation lock on the left side to the unlocked position using a coin or similar object, as shown below.

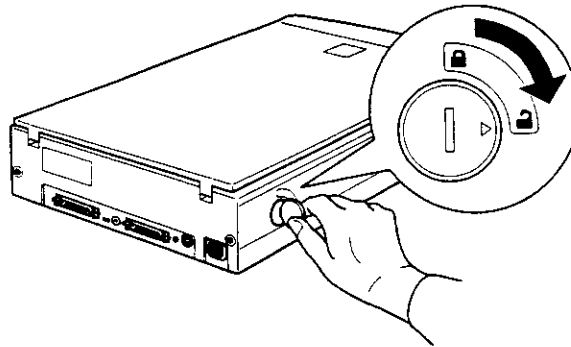

Note:

- ❑ When you cannot turn the transportation lock because of excessive resistance, turn the scanner on, then, after the operate light starts flashing red, turn the scanner off, and try again. See the next section to turn on the scanner.
- ❑ Return the transportation lock to the locked position when transporting the scanner.

Initialization

1

Before connecting the scanner to your computer, follow the steps below to make sure that the scanner is operating properly.

1. Open the document cover so you can see the operation of the scanner during initialization (startup).
2. Turn on the scanner by pressing the  Operate button. The Operate light starts flashing.
3. Make sure the fluorescent lamps on the carriage flash, and the carriage moves slightly.

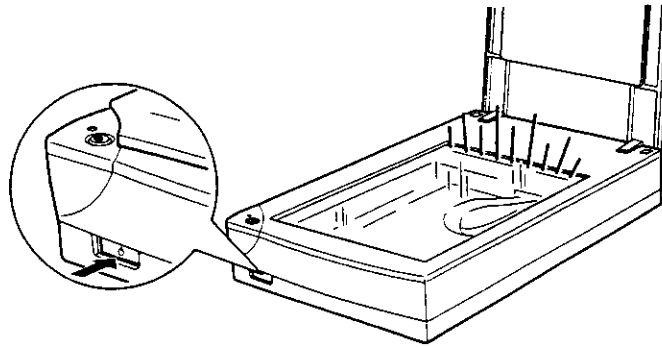

4. The Operate light stays on. This means the scanner has completed initialization.
5. Turn off the scanner.

If the scanner does not work as described, make sure that the power cord is firmly plugged in and that you have released the transportation lock, then try again.



Caution:

Whenever you turn off the scanner, wait at least 10 seconds before turning it back on. Rapidly turning the scanner on and off can damage the scanner.

Proof Sign-off:
M. Fujimori _____
<leadername> _____
<editorname> _____

Paprika-U
Rev. B

A5 size
5/26/98

CHAP1.FM
Pass 0

R

If you add the scanner to a system in which one of your SCSI devices already has a SCSI ID of 2, change the ID number to an unused number using the rotary switch. See the table below page 1 as a guide.

1

ID	Availability	Description
0	Not available for Macintosh	Used for hard disk
	Not recommended for Windows	Usually used for hard disk
1	Not recommended	Usually used for hard disk
2		Factory setting of the scanner
3		Not available if your Macintosh has a built-in CD-ROM
4		
5		
6		
7	Not available for Macintosh	Always used for the Macintosh itself
	May not be available for Windows	Usually used for the SCSI board
8,9	Not available	Never selected*

* Scanner will not work properly if selected.



Caution:

Do not set the SCSI ID to an ID number that is already assigned to another device. Otherwise the computer, scanner, and other devices will not function properly.

The scanner is the last device in the daisy chain

1

(other SCSI device)

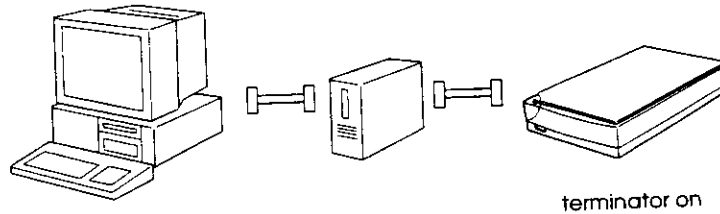

The scanner is in the middle of the daisy chain

(other SCSI device)

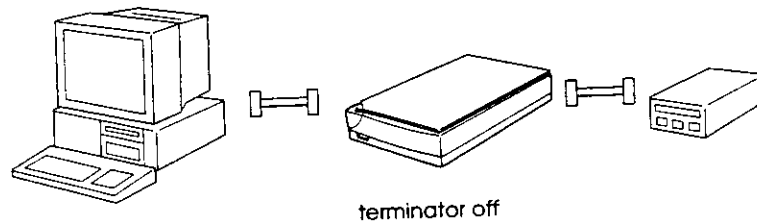

Connecting the scanner

Connect the scanner to your computer or to another SCSI device as follows:

Note:

The combination of 50-pin and 25-pin connectors you need varies depending on the maker of your SCSI device and SCSI interface board.

1. Make sure the scanner, computer, and all other SCSI devices are turned off and unplugged from the power source.



Caution:

Do not connect the scanner to the computer or other devices while they are turned on; otherwise damage may occur.

Proof Sign-off:
M. Fujimori _____
<leadername> _____
<editorname> _____

Paprika-U Rev. B

A5 size
5/26/98

CHAP1.FM
Pass 0

R

Power-on sequence

1

Keep the following in mind every time you turn on your computer and SCSI devices (such as the scanner).

- Be sure to turn on the SCSI device which is connected at the farthest end of the daisy chain first, then the second farthest etc., until finally your computer. If you attempt to use a SCSI device which has been turned on after the computer, it may not work properly, or the computer may not work properly.
- For Windows 95 or 98 users:**
The first time you turn on the computer after turning on the scanner, one of the following dialog boxes may appear.

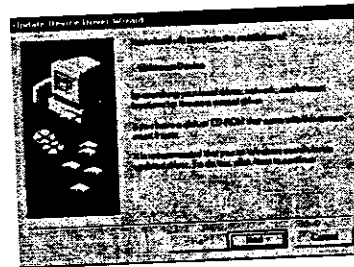
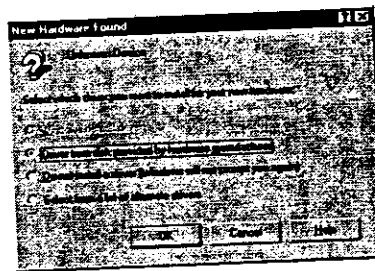

Windows 95

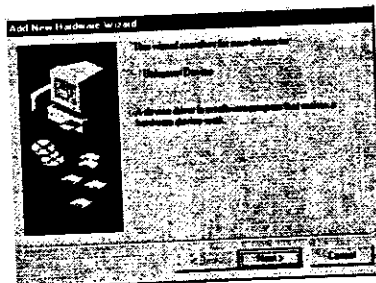

Windows 98

If you see one of these, follow the installation instructions in Chapter 1 of your scanner software manual, and then see "Power-off sequence" following.

Proof Sign-off:
M. Fujimori _____
<leadername> _____
<editorname> _____

Paprika-U
Rev. B

A5 size
5/25/98

CHAP2.FM
Pass 0

R

Chapter 2

Using Your Scanner

Lights and Buttons	2-2
Placing a Document on the Scanner	2-4
Removing the Cover for Thick or Large Documents	2-6
Sizing Up Your System	2-8
RAM and hard disk size	2-8
Accelerator boards	2-8
Video cards	2-8
Monitors	2-9
File compression software	2-9

2

Proof Sign-off:
M. Fujimori _____
<leadername> _____
<editorname> _____





Paprika-U
Rev. B

A5 size
5/25/98

CHAP2.FM
Pass 0

R



Light

Pattern	Color	Scanner Status
 (Slowly flashing)	Green	Initializing or busy scanning.
	Green	Ready to scan images.
 (Rapidly flashing)	Red or Orange	An error occurred. See Chapter ?? Troubleshooting on page ?? for more information.
	N/A	The scanner is turned off.

■ = on,  = flashing,  = off

2

Buttons

Button	Function
 Operate	Turns the scanner on and off.
 Start button	The hardware switch to execute scanning and transfer the scanned image to assigned application software. To use this feature, you need to setup software. See page ?? of EPSON Scan!!! & EPSON TWAIN User's Guide for more details.

Proof Sign-off:
M. Fujimori
<leadname>
<editname>

Paprika-U
Rev. B

A5 size
5/25/98

CHAP2.FM
Pass 0

R

4. Place the document on the document table, with the side to be scanned facing down. Make sure that the document is carefully aligned.

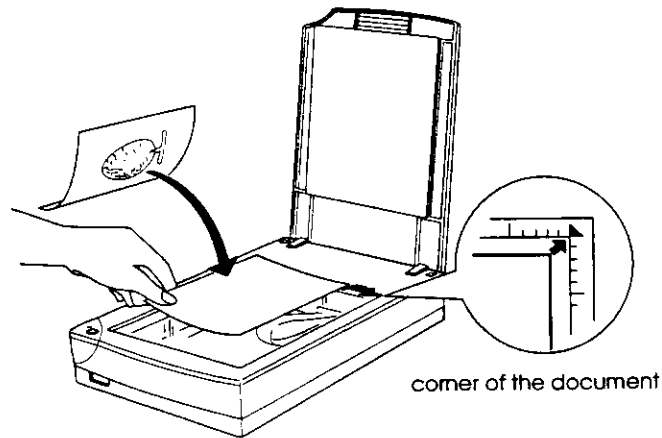

2

5. Close the document cover gently so that the document does not move.

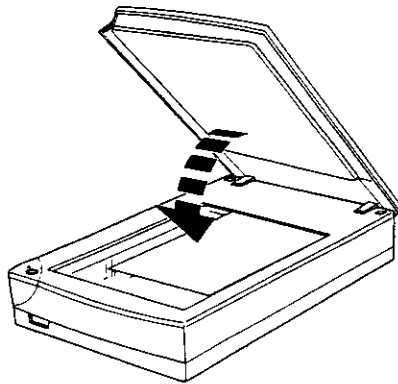

Proof Sign-off:
M. Fujimori _____
<leadername> _____
<editorname> _____

Paprika-U Rev. B

A5 size
5/25/98

CHAP2.FM
Pass 0

R

Note:

When scanning with the cover removed, make sure you cover any exposed areas of the document table to prevent interference from external light.

When you are finished scanning, reattach the document cover by pushing straight down on the back until it clicks into place.

2

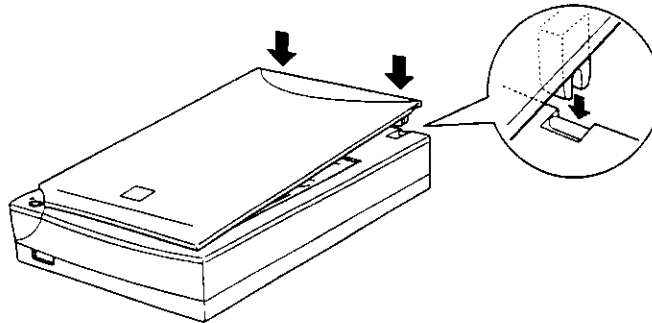

Caution:

Make sure both of the cover's notches are directly above the clips on the scanner before pushing it down into place; otherwise damage may occur.

Proof Sign-off:
M. Fujimori _____
<leadername> _____
<editorname> _____

Paprika-U
Rev. B

A5 size
5/25/98

CHAP2.FM
Pass 0

R

Monitors

The resolution of your monitor affects the quality of the image you see. Consider a high resolution monitor if you do precise color work, but also be sure you have a high quality video card.

2

File compression software

Many different programs are available to make image files smaller for storage or transmission. For example, some compression software can store a 3MB image file on a 1.44MB floppy disk, and compress images and restore them with no loss of data or quality; others compress images more, but the restored file is not exactly the same as the original. The difference between the original and restored files is, however, almost unnoticeable.

Proof Sign-off:
<antoname> _____
<leadname> _____
<editname> _____

Paprika-U
Rev. B

A5 size
5/25/98

CHAP3.FM
Pass 0

R

Chapter 3

Options

Using the Film Adapter	3-2
Unpacking the Film Adapter	3-2
Using the Film Adapter	3-3
Film Holders	3-5
Loading transparencies	3-7
Scanning normal (reflective) documents	3-11
Using the Automatic Document Feeder	3-12
Unpacking the Automatic Document Feeder	3-12
Installing the Automatic Document Feeder	3-13
Loading paper into your Automatic Document Feeder	3-15
Loading documents manually	3-17
Document specifications	3-17



Proof Sign-off:
<antname> _____
<leadname> _____
<editname> _____

Paprika-U
Rev. B

A5 size
5/25/98

CHAP3.FM
Pass 0

R

Using the Film Adapter

Follow the steps below to use the Film Adapter on the scanner.

1. Make sure the scanner is turned off.
2. Remove the document cover from the scanner by holding the cover and lifting the back of the cover straight up. (See page ?-?)
3. Place the Film Adapter on the document table so that the hinges face the rear of the scanner and it fits on the table.

3

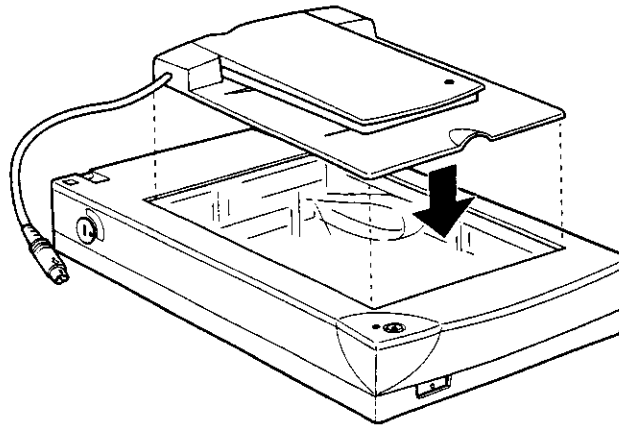

Proof Sign-off: _____
<antoname> _____
<leadname> _____
<editname> _____

Paprika-U
Rev. B

A5 size
5/25/98

CHAP3.FM
Pass 0

R

Film Holders

Three film holders for scanning film are included with this unit. To use them, see the instructions below.



Caution:

Hold the film at the edges, or else use gloves. Touching the film surface with bare hands can leave fingerprints or other traces on the film.

3

Note:

The base side of the film is the side which the film maker's name and film ID numbers are shown.

35 mm negative or positive film

Insert a strip of film in the 35 mm film holder, base side facing down.

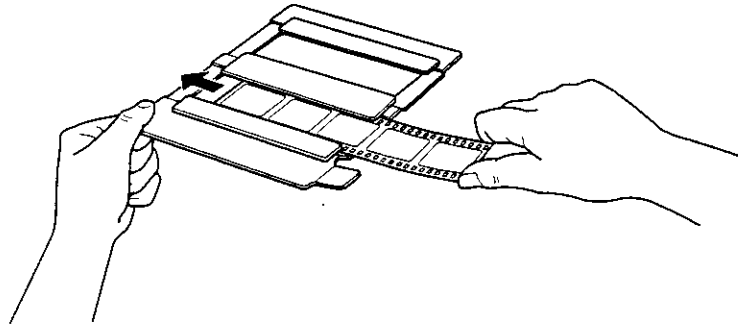

Loading transparencies

You can scan 35 mm slides or transparencies up to 4 × 5 inches (101.6 × 127 mm) in size.

Note:

- ❑ *Wipe the glass of the Film Adapter, the scanner's document table, and the narrow window near the hinge before scanning transparencies.*
- ❑ *You need to select TPU - Neg. Film or TPU - Pos. Film setting in the Document Source settings depending on the document type (negative or positive) you are scanning in your scanner software. Then the scanner software automatically controls the operation of the Film Adapter.*

3

Follow the steps below to load films or transparencies.



Caution:

Hold the film at the edges, or else use gloves. Touching the film surface with bare hands can leave fingerprints or other traces on the film.

1. Open the Film Adapter.

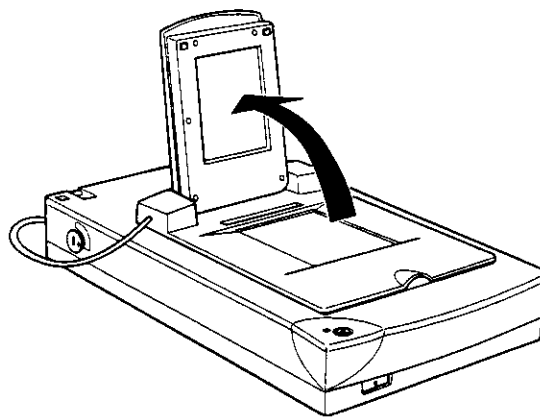

Proof Sign-off:
<tantoname> _____
<leadername> _____
<editorname> _____

Paprika-U Rev. B

A5 size
5/25/98

CHAP3.FM
Pass 0

R

Note:

- Place the film holders on the scanner's glass document table aligning it with the upper left-hand corner of the transparency guide.
- When scanning Brownie size (6cm × 9cm) or similar film, use the film holder for it as shown below.

3

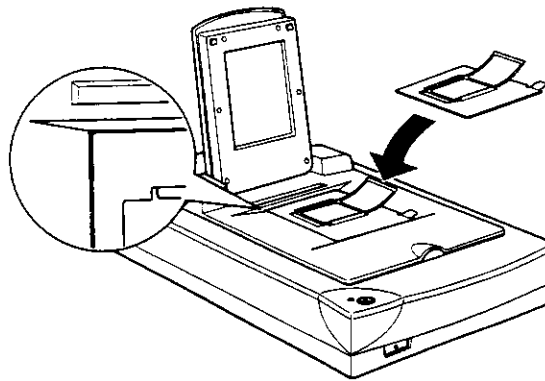

- If the film size is 4" × 5" or similar, use the film holder for it as shown below.

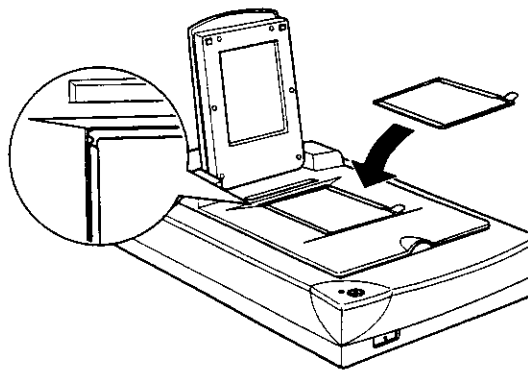

Proof Sign-off:
<antoname>
<leadername>
<editoname>

Paprika-U
Rev. B

A5 size
5/25/98

CHAP3.FM
Pass 0

R

- Leave the opening shown below uncovered, otherwise the color of the image will be affected.

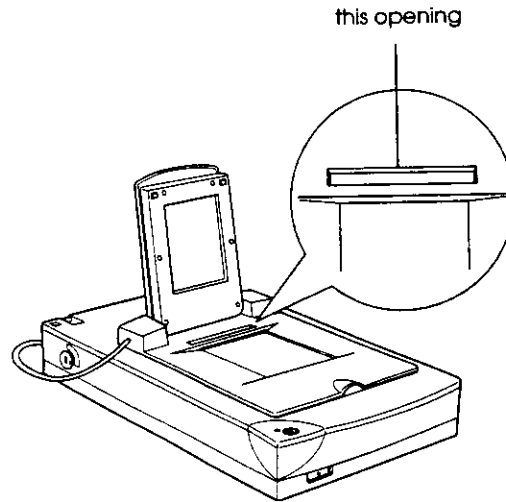

3

Scanning normal (reflective) documents

When you return to scanning normal reflective documents, you can simply turn off the Film Adapter, then place documents between it and the document table. If you will not scan transparencies for long time, you can remove the Film Adapter and store it in the original package.

Remove the Film Adapter in reverse order as described on page ??.

Proof Sign-off:
<tantoname> _____
<leadername> _____
<editorname> _____

Paprika-U
Rev. B

A5 size
5/25/98

CHAP3.FM
Pass 0

R

Installing the Automatic Document Feeder

Follow the steps below to install the Automatic Document Feeder on your EPSON scanner.

1. Make sure your scanner is turned off, and unplug the scanner's power cable.
2. Remove your scanner's document cover by holding and lifting the back of the cover straight up. (See page ??-?)
3. Insert the hinges on the Automatic Document Feeder into the holes at the back of the scanner and close the Automatic Document Feeder.

3

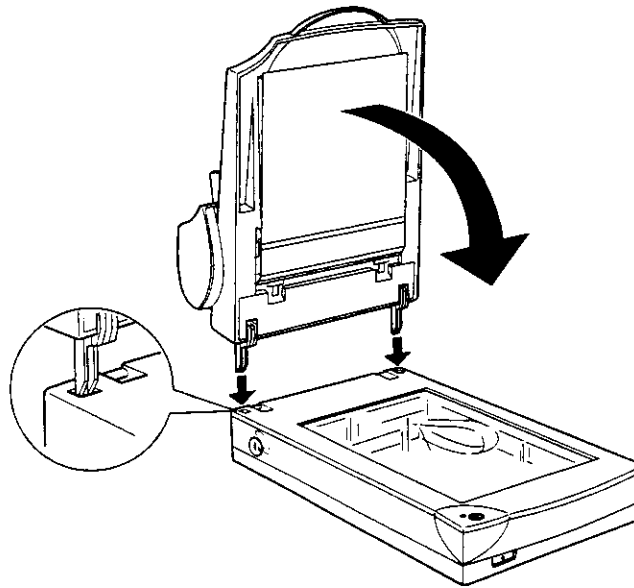

4. Remove the protective materials from the Automatic Document Feeder.

Loading paper into your Automatic Document Feeder

Your Automatic Document Feeder can automatically load up to 20 sheets of the following paper sizes (based on a paper weight of 17 lbs and a stack thickness of 4.0 mm or less):

Checks	83 × 127 mm (3.3 × 5 inches)
B5	182 × 257 mm (7.17 × 10.1 inches)
A4	210 × 297 mm (8.27 × 11.69 inches)
Letter	215.9 × 279.4 mm (8.5 × 11 inches)
Legal	215.9 × 355.6 mm (8.5 × 14 inches)

3

Follow the steps below to load paper into the Automatic Document Feeder.

1. Slide the right edge guide all the way to the right.

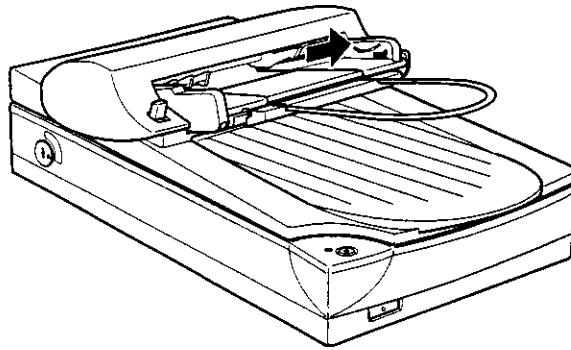

Loading documents manually

You can load documents manually even when the Automatic Document Feeder is installed.

To load manually, lift the Automatic Document Feeder and place the document on the scanning surface. Then lower the Automatic Document Feeder and scan the document.

Note:

- Opening the Automatic Document Feeder or its cover while it is operating results in an option error and paper feeding stops.*
- Always close the Automatic Document Feeder and its cover before using it.*
- Be sure to select Flatbed in the Document Source settings in EPSON TWAIN.*



Document specifications

Size:	Width 3.3 to 8.5 inches (83 to 215.9 mm) Length 5 to 14 inches (127 to 355.6 mm)
Thickness:	0.07 to 0.16 mm
Weight:	58 to 122 g/m ²
Paper quality:	High-quality bond or thermal paper
Document type:	Documents printed with impact printers, laser printers, or facsimile machines

Proof Sign-off:
<antname> _____
<leadname> _____
<editname> _____

Paprika-U
Rev. B

A5 size
5/25/98

CHAP4.FM
Pass 0

R

Chapter 4

Maintenance and Troubleshooting

Maintenance	4-2
Cleaning the scanner	4-2
Replacing the fluorescent lamps	4-3
Cleaning or replacing the paper path guide.....	4-3
Transporting the Scanner	4-8
Problems and Solutions	4-9
Error indicators.....	4-9
Operating problems	4-10
Quality problems	4-12
Clearing Jammed Paper	4-16



Replacing the fluorescent lamps

The luminosity of the fluorescent lamps declines over time. If the lamps break or become too dim to operate normally, the scanner stops working and the operate light flashes rapidly in red. When this happens, the lamp assembly must be replaced. For details, contact your dealer.



Caution:

Never open the case of the scanner. If you think repairs or adjustments are necessary, consult your dealer.

4

Cleaning or replacing the paper path guide

To keep scanning quality at its best when using the Auto Document Feeder, clean the paper path guide if you notice the quality of your scans have declined.

If the paper path guide gets badly scratched and cleaning the guide does not improve the quality of your scans, replace it with the spare one.

Follow the instructions below to remove, clean, and reattach the paper path guide.

Proof Sign-off:
<tantoname>
<leadername>
<editorname>

Paprika-U Rev. B

A5 size
5/25/98

CHAP4.FM
Pass 0

R

4. Put the Auto Document Feeder on the document table upside down, with the front of the Auto Document Feeder towards you.
5. Pull the two white hooks up, and then back down out of the through holes.

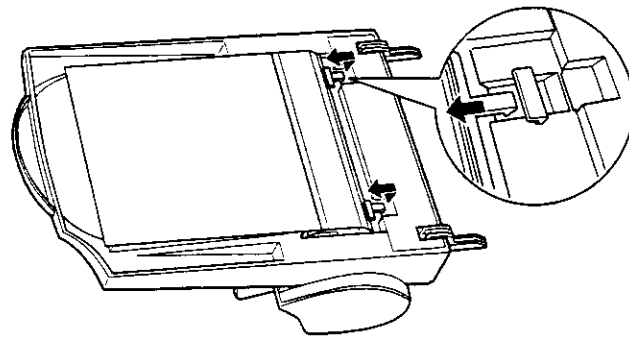

4

6. Pull the paper path guide upwards.

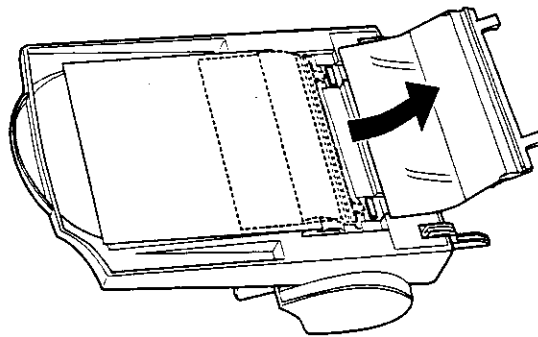

Proof Sign-off:
<antoname>
<leadername>
<editorname>

Paprika-U
Rev. B

A5 size
5/25/98

CHAP4.FM
Pass 0

R

2. Insert the hooks into the rectangular through holes in the rear direction of the Auto Document Feeder. Make sure that the hooks clip into place.

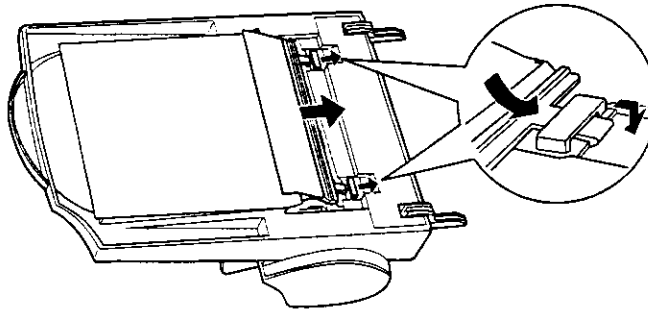

4

Problems and Solutions

This section divides scanner problems into three categories:

Error indicatorspage ??
Operating problemspage ??
Quality problemspage ??

See the table in "Error indicators" first. If the information there does not help you solve the problem, go to the category for the type of problem you have, then look for the description that most closely matches the problem.

The online Color Guide will provide you with further helpful information on various problems and versatile tips.

4

Error indicators

If an error occurs, the scanner stops operating and the Operate light shows the type of error.

Pattern of light	Problem and solution	
□ (Rapidly flashing in red)	Cause 1:	The interface setup is wrong, or the scanner is not properly connected to the computer.
	What to do 1:	Check the interface connection. Then turn the scanner off and back on to reset it.
	Cause 2:	The transportation lock has not been released. Or, one or more fluorescent lamps need to be replaced. Or, the scanner is broken.
	What to do 2:	Make sure that the transportation lock is in the unlocked position; then turn the scanner off and then back on. If the scanner still does not operate properly, or if this error occurs repeatedly, consult your dealer.

Proof Sign-off:
<antoname> _____
<leadername> _____
<editorname> _____

Paprika-U
Rev. B

A5 size
5/25/98

CHAP4.FM
Pass 0

R

The Operate light does not come on.

Press the Operate button to turn on the scanner.

Make sure the power cable is correctly plugged into the scanner and the power outlet.

The scanner does not start scanning.

Make sure that the operate light is green (in ready state).

Make sure that you have selected the correct interface port and settings with your software. Also make sure the interface board in your computer is properly installed.

Make sure that the terminator and SCSI ID are correctly set up. See page ??.

If you have other expansion boards in your computer, make sure that they are not interfering with the interrupt setting of the interface board for your scanner. (See your computer manual.)

The scanner software does not work properly.

Be sure you have correctly installed your software.

Make sure that your computer system meets the requirements, such as the operating system version, specified for your software.

Confirm that the computer has enough memory for your software. If your computer has many device drivers, or if you are running other software at the same time, or using RAM-resident programs, the computer may not have enough memory available. (See your software and computer manuals.)

4

Proof Sign-off:
<tantname> _____
<leadname> _____
<editname> _____

Paprika-U
Rev. B

A5 size
5/25/98

CHAP4.FM
Pass 0

R

If part of the document extends beyond the document table, that edge may not be in contact with the document table. Change the position of the document.

The image is faint or out of focus.

Check that the document is placed flush against the document table.

Check the Gamma setting in your software.

Check the Exposure setting in your software.

4

The image is too dark.

Adjust the brightness with your software. Also check the brightness and contrast values of your display screen.

Straight lines in the image are jagged.

The document may be placed at an angle on the document table. Align it so that the horizontal and vertical lines are carefully aligned with the scales on the top and side of the document table.

The image does not look the same as the original.

Try different combinations of image settings using your scanner software.

Your software may not have sufficient color matching and color management features, or these components of your software may not be correctly installed. (See your software and computer manuals.)

Proof Sign-off:
<stantoname> _____
<leadername> _____
<editorname> _____

Paprika-U
Rev. B

A5 size
5/25/98

CHAP4.FM
Pass 0

R

Colors on your monitor are different from those in the original image.

Check the image settings in your scanner software, especially data format (bits/pixel/color), gamma correction, and color correction. Try a different combination of these settings.

Check the color matching and color management capabilities of your computer, display adapter, and software. Some computers can change the color palette to adjust the colors on your screen. (See your software and computer manuals.)

Exact matching of colors is very difficult. The reason for this is explained in your *Color Guide*. Check your software and monitor manuals for information on color matching and calibration.

4

Printed colors are different from those in the original image.

Exact reproduction of colors is very difficult. The reason for this is explained in your *Color Guide*. See your software manual or your printing company for guidance on color matching.

The printed image is larger or smaller than the original size.

The image size settings in your software determine the size of the printed image. Do not use the size of the image on your monitor to judge the printed size.

Your image cannot be printed or the printout is garbled.

Check that the printer is properly connected to the computer and is correctly set up. (See your printer manual.)

Check that your software is properly installed and set up for your printer. (See your software manual.)

Proof Sign-off:
<antoname>
<leadername>
<editorname>

Paprika-U
Rev. B

A5 size
5/25/98

CHAP4.FM
Pass 0

R

4. If paper is still jammed inside the mechanism, open the cover to remove it.

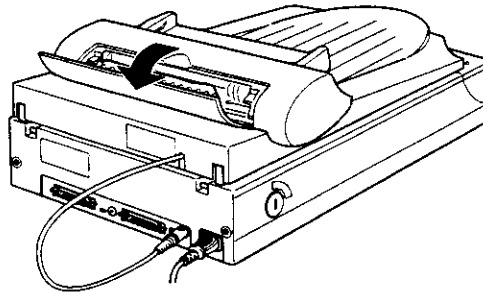

4

5. After removing jammed paper, make sure that the cover is closed, and push the feeder mechanism down until it clicks into place.

Proof Sign-off:
<antname> _____
<leadname> _____
<editname> _____

Paprika-U
Rev. B

A5 size
5/26/98

APP-A.FM
Pass 0

R

Appendix A

Technical Specifications

Scanning A-2
Electrical A-4
Environmental A-4
Safety Approvals A-5
CE marking A-5
SCSI Interface A-6
Initialization Methods A-7



Proof Sign-off:
<tantoname> _____
<leadername> _____
<editorname> _____

Paprika-U
Rev. B

A5 size
5/26/98

APP-A.FM
Pass 0

R

Halftoning process: AAS (Auto Area Segmentation)
Enable/disable selectable
3 halftoning modes (A, B, and C) and
4 dither patterns (A, B, C, and D) for
bi-level and quad-level data
(2 downloadable dither patterns)

Gamma correction: 2 types for CRT display
3 types for printer
1 type for user-defined

Color correction: 1 type for CRT display
3 types for printer output (available in color
byte sequence mode and color line sequence
mode)
1 type for user-defined

Interface: SCSI (50 pin half pitch connectors)

Light source: White cold cathode fluorescent lamp

Reliability: 30,000 cycles of carriage movements
(main unit MCBF)

Dimensions: Width: 287 mm (11.3 inches)
Depth: 425 mm (16.7 inches)
Height: 88 mm (3.4 inches)

Weight: Approx. 4.5g (9.9 lb)



Proof Sign-off:
<tantoname> _____
<leadername> _____
<editorname> _____

Paprika-U
Rev. B

A5 size
5/26/98

APP-A.FM
Pass 0

R

Safety Approvals

120V model:	
Safety standards	UL 1950 with D3 CSA C22.2 No. 950
EMI	FCC part 15 subpart B class B CSA C108.8 class B
230V model:	
Safety standards	EN 60950
EMC	EN 55022 (CISPR Pub 22) class B AS/NZS 3548 class B

A

CE marking

230 V model:	
Low Voltage Directive 73/23/EEC	EN 60950
EMC Directive 89/336/EEC	EN 55022 Class B EN 61000-3-2 EN 61000-3-3 EN 50082-1 IEC 801-2 IEC 801-3 IEC 801-4

Proof Sign-off:
<tantoname> _____
<leadername> _____
<editorname> _____

Paprika-U
Rev. B

A5 size
5/26/98

APP-A.FM
Pass 0

R

Initialization Methods

The scanner can be initialized (returned to a fixed set of conditions) in the following ways:

Hardware initialization	<ul style="list-style-type: none">• The scanner is turned on.• The scanner receives a SCSI Reset signal from the SCSI interface.
Software initialization	<ul style="list-style-type: none">• Software sends the ESC @ (initialize the scanner) command.• The scanner receives a SCSI Bus Device Message.

A

Proof Sign-off:
<tantoname> _____
<leadername> _____
<editorname> _____

Paprika-U
Rev. B

A5 size
5/26/98

APP-B.FM
Pass 0

R

Appendix B

Contacting Customer Support

For United Kingdom and the Republic of Ireland Users B-3
For Australian Users B-5
For Singapore Users B-6
For Hong Kong Users B-7
For Philippines Users B-8

B

Proof Sign-off:
<antname> _____
<leadname> _____
<editname> _____

Paprika-U Rev. B

A5 size
5/26/98

APP-B.FM
Pass 0

R

For United Kingdom and the Republic of Ireland Users

If you purchased your printer in the UK or the Republic of Ireland, EPSON (UK) Limited provides a range of customer services and technical support:

- World Wide Web
- Faxon EPSON Faxback
- Bulletin Board Service
- Customer and Warranty Support
- Pre Sales Enquiry Desk

See the following sections for details.

World Wide Web

If you can connect to the Internet and have a Web browser, you can access our Web site at <http://www.epson.co.uk>. Here you will find information on the latest EPSON products, software drivers, on-line user guides, and answers to frequently asked questions.

B

Faxon EPSON

Contact Faxon EPSON Faxback Service for support information including troubleshooting tips, switch settings, and driver information.

To use Faxon EPSON, call 01442 227332 in the UK or 0044 1442 227332 from the Republic of Ireland using a touch-tone phone. You will be asked to follow a simple routine to register your document request. Once you have entered your telephone and fax numbers, Faxon EPSON will fax a copy of the document catalogue to your fax machine.

When you have found the documents that you need in the catalogue, call Faxon EPSON again and enter the document ID numbers. The documents will be faxed to you automatically.

Proof Sign-off:
<stantoname> _____
<leadername> _____
<editorname> _____

Paprika-U **Rev. B**

A5 size
5/26/98

APP-B.FM
Pass 0

R

For Australian Users

EPSON Australia wishes to provide you with a high level of Customer Service. As well as this *User's Guide*, we provide the following sources for obtaining information:

EPSON FAXBACK

EPSON FAXBACK will fax you the latest specifications and pricing for most EPSON products offered in Australia. There is also technical information including details of the latest software and drivers available. Phone (02) 9903 9075 and the system will guide you through a number of choices before faxing the information to your fax machine.

EPSON Bulletin Board System

This is where you can download the latest software and drivers. Visit the BBS to check out the latest versions. If you have a modem, phone (02) 9417 5090.

Internet URL <http://www.epson.com.au>

Access the EPSON Australia World Wide Web pages. Worth taking your modem here for the occasional surf! You can get the same information as offered on the EPSON FAXBACK and the EPSON Bulletin Board plus more.

Your dealer

Don't forget that your dealer can often help identify and resolve problems. The dealer should always be the first call for advice on problems. They can often solve problems quickly and easily as well as give you advice on the next step to take.

B

Proof Sign-off:
<antoname> _____
<leadername> _____
<editorname> _____

Paprika-U
Rev. B

A5 size
5/26/98

APP-B.FM
Pass 0

R

For Hong Kong Users

To obtain technical support as well as other after-sales services, users are welcome to contact EPSON Hong Kong Limited.

Internet home page

EPSON Hong Kong has established a local home page in both Chinese and English on the Internet to provide users with the following information:

- Product information
- Answers to Frequently Asked Questions (FAQs)
- Latest versions of EPSON printer drivers

Users can access our World Wide Web home page at:
<http://www.epson.com.hk>

Electronic bulletin board system

An electronic bulletin board system (BBS) is also available to obtain printer information and the latest versions of printer drivers. You can log on to the following number for the BBS service:

BBS: (852) 2827-4244

Technical Support Hotline

You can also contact our technical staff at the following telephone and fax numbers:

Phone: (852) 2585-4399
Fax: (852) 2827-4383

B

Glossary

additive primary colors

Primary colors which produce white when mixed in certain amounts. These are red, green, and blue — the colors of the scanner lamps and color monitor displays.

bi-level data

Image data that is composed of 1 bit per pixel. A pixel is represented by a single bit of digital data that can express only 1 (light) or 0 (dark).

bit

Short for binary digit. The smallest unit of data in computer processing. A bit can represent two values: on and off, or 1 and 0.

bit/pixel

The unit that indicates the number of bits allocated for a pixel. The larger the bit value, the more detail of a pixel will be reproduced.

brightness

A scanner function to lighten or darken the output image data.

byte

A unit of information consisting of eight bits. A byte can represent a control code or character.

carriage

A component of the scanner that contains the optical sensor and light source for scanning.

color correction

A method of adjusting the color image data for a particular type of device so that the reproduction results are as close as possible to the original colors.

color separation

A process to convert full-color images into a limited number of primary colors. The additive primary colors (red, green, and blue) are used by the scanner, and the subtractive primary colors (cyan, magenta, and yellow) plus black are used for printing press separation.

daisy chain

A SCSI bus arrangement that allows several devices to be connected simultaneously in a line to a single computer. See *SCSI*.

default

A set of values used when no other selections have been made. These are sometimes called factory defaults if the original values have not been changed since the scanner has left the factory.

line sequence

A type of color scanning that separates primary colors line by line. The carriage makes only one pass.

monochrome

Black and white images, or images represented only by the intensity of luminosity.

page sequence

The type of color scanning in which the entire image is scanned once for each separation color.

pixel

Short for picture element. Each image is composed of a number of pixels. Pixels are also counted in units of dots.

plain bi-level

Bi-level image data without the halftoning process.

port

An interface channel through which data is transmitted between devices.

primary colors

Basic colors. See *additive primary colors* and *subtractive primary colors*.

resolution

Indication of how finely an image is resolved into pixels. Measured in dots per inch (dpi), pixels per inch (ppi), or samples per inch (spi).

scan

An operation performed by the sensor and the carriage. The image is divided into pixels by scanning.

scanning area

The physical size of the image that can be scanned by the scanner.

SCSI

Small Computer System Interface. This is one method used to connect your computer to peripherals such as scanners, hard disk drives, CD-ROM drives, and so on.

SCSI ID

The numbers that all devices in a SCSI connection (see *daisy chain*) use to identify each other. If the same ID number is used by two devices in the same daisy chain, the devices cannot operate properly.

subtractive primary colors

Primary colors that produce black when mixed in certain amounts. These are cyan, magenta, and yellow. In printing, black is often added to give more definition as mixing of actual inks cannot produce pure black.

L

Paprika-U
Rev. B

A5 size
5/26/98

GLOSSARY.FM
Pass 0

Proof Sign-off:

<antname>

<leadname>

<editname>

terminator

A device that stops electronic signals, and prevents them from proceeding or returning to other devices. This is necessary to stop a signal from continuously bouncing between devices.

threshold

A reference point that is used to determine whether data will be processed as "on" or "off". In the case of color image data, "on" means that a certain color will appear in a pixel or dot, and "off" means that color will not appear there.

tone correction

A method of adjusting the tone curve so that the reproduction results on different types of output devices have gradations similar to the original image.

tone curve

The graph that shows the contrast ratio between the input (original image) and output (image data) in image processing.

dithering

A process in which software or an output device simulates continuous tones with groups of dots.

document

The physical item, such as a sheet of paper or a book, that you place on the document table for the scanner to read.

dpi

Short for dots per inch. A unit of measurement for resolution. The higher the value, the higher the resolution.

dropout color

A color the scanner does not recognize and ignores. You can select and deselect dropout colors in the scanner software.

ESC/I

Abbreviation for EPSON Standard Code for Image scanners. A system of commands that allows you to control image scanners from your software.

ESC/P

Abbreviation for EPSON Standard Code for Printers. A system of commands that allows you to control printers from your software.

grayscale

Images represented with various shades of gray in addition to black and white.

halftoning

A method of reproducing images with patterns of dots to improve the quality of the output.

home position

The position at the rear (nearest the cover hinge position) of the scanner where the carriage rests before a scanning operation.

imagesetter

A device that uses computer files to produce high-resolution text and graphics output on film or paper. These are usually found in service bureaus and printing companies.

impact dot printer

A printer that transfers ink onto the paper by striking an ink ribbon with a number of small pins.

ink jet printer

A printer that transfers ink onto the paper by spraying the ink through a number of small nozzles.

interface

A piece of hardware, a method, or a standard used for connection between or among computer devices.

L

Paprika-U
Rev. B

A5 size
5/26/98

APP-B.FM
Pass 0

Proof Sign-off: _____
<tantoname> _____
<leademame> _____
<editomame> _____

For Philippines Users

To obtain technical support as well as other after sales services, users are welcome to contact the EPSON Philippines Representative Office at the telephone and fax numbers below:

Phone: (632) 813-6552
Fax: (632) 813-6545
BBS: (632) 814-0595

L

Paprika-U
Rev. B

A5 size
5/26/98

APP-B.FM
Pass 0

Proof Sign-off:
<!antoname>
<leadername>
<editorname>

EPSON Helpdesk

EPSON Helpdesk is provided as a final backup to make sure our clients have access to advice. Operators on the Helpdesk can aid you in diagnosing hardware and software problems. They can also advise you on the latest EPSON products and where the nearest dealer or service agent is located. Many types of queries are answered here.

The Helpdesk numbers are:

Phone: (02) 9903 9040
Fax: (02) 9903 9189

We encourage you to have all the relevant information on hand when you ring. The more information you prepare, the faster we can help solve the problem. This information includes the *User's Guide* for your EPSON product, type of computer, operating system, application programs, and any other information you feel is required.

For Singapore Users

Contact the telephone and fax numbers below:

Phone: (065) 337-7911
Fax: (065) 334-1185

L

Paprika-U
Rev. B

A5 size
5/26/98

APP-B.FM
Pass 0

Proof Sign-off:
<antoname> _____
<leadename> _____
<editormame> _____

Bulletin Board Service for latest drivers and utilities

You can call the EPSON Bulletin Board Service on 01442 227479 in the UK or 0044 1442 227479 from the Republic of Ireland. No membership is required. Make sure that your communications software is set to 8 data bits, 1 stop bit, no parity bit, ANSI terminal mode emulation, and a modem speed of up to 28.8 Kbps. Downloading protocols supported include Xmodem, Ymodem and Zmodem. See the documentation that came with your communications software and modem for more information.

When you first connect to the Bulletin Board Service, you will be asked for your name, company name, phone number and a password (which you can invent yourself).

Customer and Warranty Support

Our Customer and Warranty Support teams can be contacted by calling 0870 163 7766 in the UK or 0044 0870 163 7766 from the Republic of Ireland. They can provide the following services:

- Technical information on installing, configuring, and operating your EPSON products
- Arranging for faulty EPSON products to be repaired within the warranty period

A full list of EPSON Customer and Warranty Support services is available on the technical support section of our world wide web pages at <http://www.epson.co.uk/support/> and on Faxon EPSON Faxback service in document number 5085.

Pre Sales Enquiry Desk

The Enquiry Desk team can be contacted by calling 0800 220546 in the UK or 1 800 409132 from the Republic of Ireland, by faxing 01442 227271 in the UK or 0044 1442 227271 from the Republic of Ireland, and via Email at info@epson.co.uk. They can provide the following information:

- Pre Sales information and literature on new EPSON products (also available via our world wide web site at <http://www.epson.co.uk>)
- Where to purchase genuine EPSON consumables, accessories, and options

L

Paprika-U
Rev. B

A5 size
5/26/98

APP-B.FM
Pass 0

Proof Sign-off:
<tantoname> _____
<leadername> _____
<editorname> _____

If your scanner is not operating properly and you cannot solve your problem using the troubleshooting information in this guide or online help, contact customer support services for assistance.

We will be able to help you more quickly if you are able to give the exact information indicated below.

Serial number of your scanner:
(The serial number label is on the back of the scanner.)

Brand and model of your computer:

Scanner software version:
(Click the About button on the Help menu in your application for the version number.)

Version of Windows (95, 3.1, NT 4.0, and so on):

Software application(s) you normally use with your scanner and their version number(s):

L

Paprika-U
Rev. B

A5 size
5/26/98

APP-A.FM
Pass 0

Proof Sign-off:
<tantoname>
<leadename>
<editoname>

SCSI Interface

- Interface type: ANSI X3T9.2/375R Revision 10L (SCSI 2)
- Functions:
 - BUS FREE phase
 - ARBITRATION phase
 - SELECTION/RESELECTION phase
 - COMMAND phase
 - (Logical Unit Number is fixed to 0 and command link function is not supported.)
 - DATA phase
 - Data in phase
 - Data out phase
 - STATUS phase
 - MESSAGE phase
 - MESSAGE IN phase
 - MESSAGE OUT phase
 - ATTENTION condition
 - RESET condition
- Logic level: TTL compatible
- Electrical standard: ANSI X3T9.2/375R Revision 10L (SCSI 2)
- ID Setting: Selectable from 0 to 7
- Terminator: Internal terminator selectable (enable/disable)
- Connector type: Two half pitch 50-pin connectors
- Connector pin arrangement:

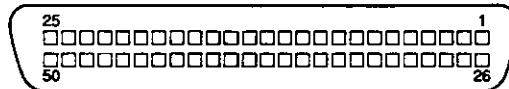

L

Paprika-U
Rev. B

A5 size
5/26/98

APP-A.FM
Pass 0

Proof Sign-off:
<antname> _____
<leadname> _____
<editname> _____

Electrical

This product is also designed for IT power systems with Phase to Phase voltage 220-240V.

	100-120 V model	220-240 V model
Input voltage range	AC 90 to 132 V	AC 198 to 264 V
Rated frequency	50 to 60 Hz	
Input frequency	49.5 to 60.5 Hz	
Rated current	0.5 A	0.3 A
Power consumption	Approx. 20W	

Note:
Check the label on the back of the scanner for the voltage of your scanner.

Environmental

Temperature:

Operation 5° C to 35° C (41° F to 95° F)

Storage -25° C to 60° C (-13° F to 140° F)

Humidity:

Operation 10% to 80%, without condensation

Storage 10% to 85%, without condensation

Operating conditions:

Ordinary office or home conditions.
Extreme dust should be avoided.
Operation under direct sunlight or near a
strong light source should be avoided.

Note:
Specifications are subject to change without notice.

Scanning

Scanner type:	Flatbed, color
Photoelectric device:	Color CCD line sensor
Effective pixels:	5100 × 7020 pixels at 600 dpi, 100%
Document size:	216 mm × 297 mm (8.5 inches × 11.7 inches A4 or US letter size (The reading area can be specified from your software.)
Scanning resolution:	600 dpi (main scan) 1200 dpi (subscan)
Output resolution:	50 dpi to 9600 dpi in 1 dpi steps (Values above 4800 dpi are interpolated)
Color separation:	RGB color filters on CCD
Reading sequence:	
Monochrome	One-pass scanning
Color page sequence	Three-pass scanning (R, G, B)
Color byte sequence	One-pass scanning (R, G, B)
Color line sequence	One-pass scanning (R, G, B)
Zoom:	50% to 200% in 1% increments
Image data:	12 bits per pixel per color internal 8 bits per pixel per color external
Brightness:	7 levels
Line Art settings:	Fixed threshold Text Enhancement Technology (enable/disable selectable)

L

Paprika-U
Rev. B

A5 size
5/25/98

CHAP4.FM
Pass 0

Proof Sign-off:
<tantoname>
<leadername>
<editorname>

Clearing Jammed Paper

To clear jammed paper in the optional Auto Document Feeder, follow the steps below:

1. Turn off the scanner.
2. Push down the release lever to slightly raise the feeder mechanism and release the paper.

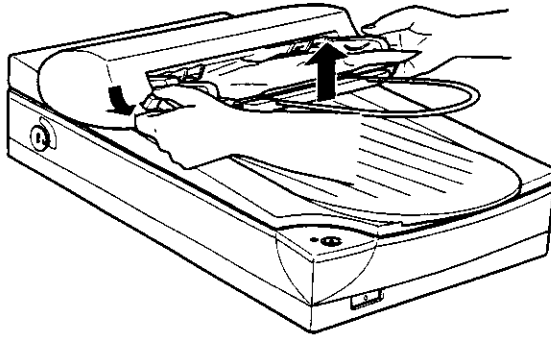

3. Then slowly pull the jammed paper out of the feeder mechanism. (Be careful not to pull too hard; the paper may tear, making it more difficult to remove.)

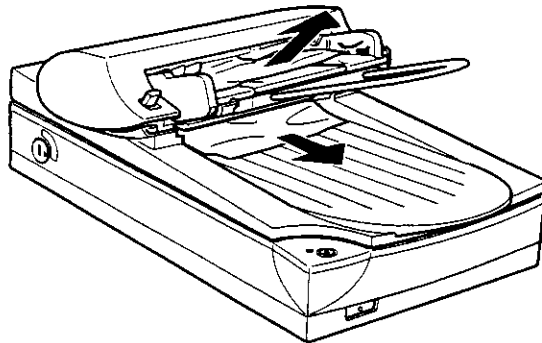

If you are importing an image file into your application software, make sure the file format is one your software can read. Also check that the image settings in your application are appropriate for the type of image you want to scan. (See your software manual.)

A line of dots is always missing in the scanned image.

If this happens in your printed image only, your printer or its print head is probably malfunctioning. (See your printer manual.)

If this happens on both your screen and printout, the scanner's sensor may be malfunctioning. Consult your dealer.

A line of dots always appears in the scanned image.

If this happens on both your screen and printout when you are using Auto Document Feeder, the paper path guide of the Auto Document Feeder may be dusty or scratched. Clean the paper path guide as described on page ???. If still the problem does not go away or the guide is badly scratched, replace the paper path guide.

When halftoning is used, textured patterns of dots appear on particular areas of an image.

This is normal. See the explanation of moiré patterns in the *Color Guide*. Your scanner automatically minimizes the problem if Best & de-screening is selected as the Quality & de-screening setting in the Image Type dialog box.

Quality problems

The entire image is distorted or blurred.

Make sure that the document is placed flat against the document table.

You may have accidentally moved the document during scanning. Check the position of the document and do not move it while the scanner is operating.

See that the scanner is not tilted or placed on an unstable surface.

Part of the image is distorted or blurred.

Part of the document may be wrinkled, warped, or not in contact with the document table. Be sure the document is uniformly flat.



Caution:

Do not place heavy objects on the document table.

Edges of the document are not scanned.

The document table has non-readable areas around the edges. If part of your document extends beyond the maximum limits marked on the document table edge guides, you may have to reposition your document so that the image you want to scan is within the readable area.

Color is patchy or distorted at the edges of the image.

If the document is very thick or warped at the edges, the edges of the image may be discolored. Cover the edges of the document with opaque paper to block outside light.

<input type="checkbox"/> (Rapidly flashing in orange (red and green))	Cause 1:	The cover of the optional Auto Document Feeder is open, or the release lever is pressed and paper feeding unit is released.
	What to do 1:	Make sure that the cover of optional Auto Document Feeder is closed and/or push the paper feeding unit down until it clicks into place.
	Cause 2:	No paper is loaded, or paper has jammed in the Auto Document Feeder.
	What to do 2:	Load paper in the Auto Document Feeder, or turn the scanner off and remove jammed paper from the Auto Document Feeder. See page ?? for details.

■ = on, □ = off, = flashing

Operating problems

The problems you may have while using the scanner often involve the operation of your software and computer. Operation problems usually occur because of:

- Incorrect setup of the interface (see Chapter 1).
- Inappropriate selection of the scanner functions (see your software manual).
- Incorrect setup of your computer or software (see Chapter 1 in this guide or the software manual).
- Incorrect operation of your software (see your software manual).

Also see the documentation that came with your computer and printer for possible solutions.

Transporting the Scanner

If you are transporting the scanner a significant distance or storing it for an extended period, follow the steps below to secure the carriage.

1. Turn on the scanner and wait until the carriage moves to the home position (position nearest the cover hinges). Then turn off the scanner.
2. Turn the transportation lock to the locked position to secure the carriage.

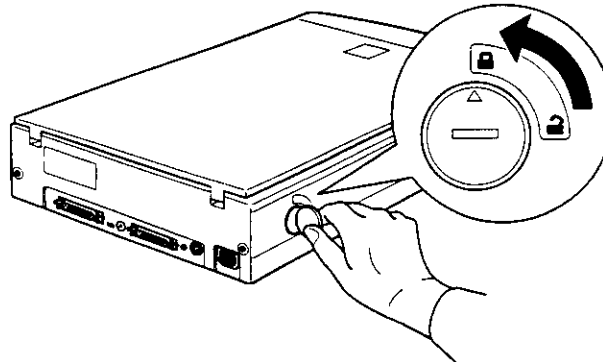
**Note:**

- If the scanner is broken, the carriage may not automatically return to the home position. If it does not, raise the front of the scanner and hold it up until the carriage comes to rest in the home position. Then perform step 2 above.
- If you are using the Film Adapter and it is switched on, the carriage will not move to its home position. Remove the Film Adapter first, then perform the steps above.

Cleaning the paper path guide

Gently wipe off dust on the transparent plastic sheet of the paper path guide with a soft dry cloth.

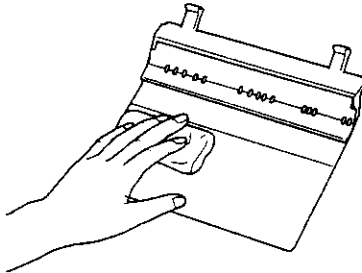

Caution:

- Be careful not to scratch or damage the paper path guide.
- Be careful not to touch and damage the rollers and metal parts in the Auto Document Feeder.

Attaching the paper path guide

1. Insert the transparent plastic part of the paper path guide in the paper path of the Auto Document Feeder.

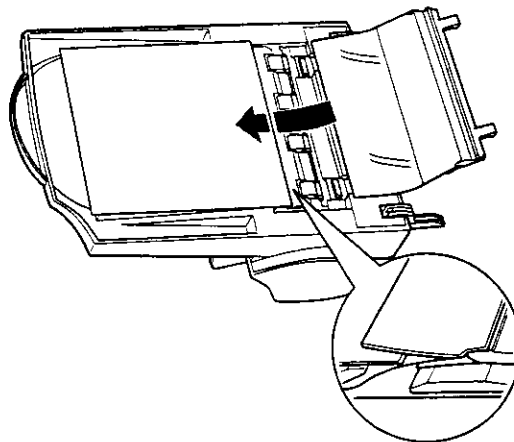

Removing the paper path guide

1. Turn off the scanner.
2. Disconnect the cable for the Auto Document Feeder, and take the Auto Document Feeder off the scanner.

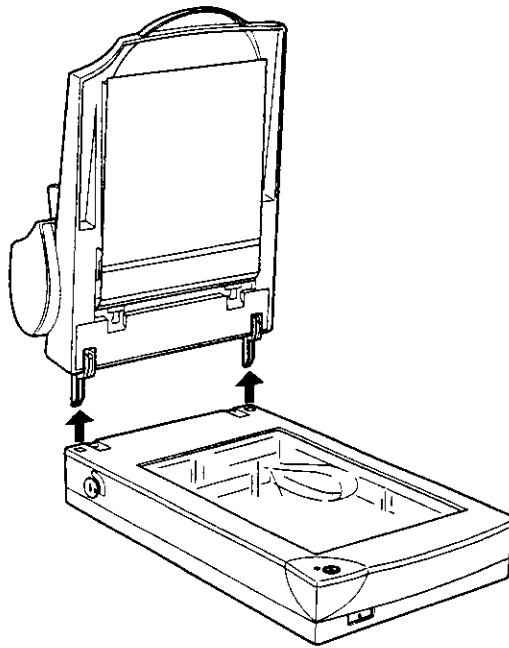

3. Take the paper support off.

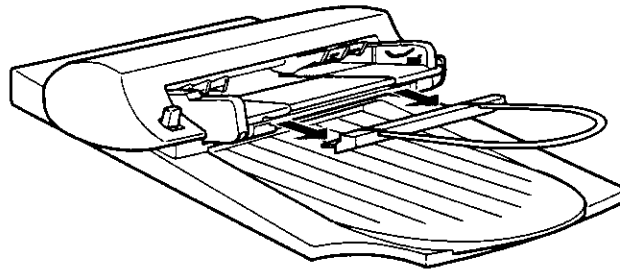

Maintenance

Cleaning the scanner

To keep your scanner operating at its best, you should clean it periodically, as described below.

1. Unplug the power cable.
2. Clean the outer case with mild detergent diluted with water.
3. If the glass of the document table gets dirty, clean it with a soft dry cloth. If the glass is stained with grease or some other hard-to-remove material, use a small amount of glass cleaner on a soft cloth to remove it. Wipe off any remaining liquid with a dry cloth.

Be sure that there is no dust on the glass of the document table. Dust can cause white spots in your scanned image.

**Caution:**

- Be careful not to scratch or damage the glass of the document table, and do not use a hard or abrasive brush to clean it. A damaged glass surface can decrease the scanning quality.*
- Never use alcohol, thinner, or corrosive solvent to clean the scanner. These chemicals can damage the scanner components as well as the case.*
- Be careful not to spill liquid into the scanner mechanism or electronic components. This could permanently damage the mechanism and circuitry.*
- Do not spray lubricants inside the scanner.*
- Never open the scanner case.*

Document conditions

Check the following before feeding a document:

- Ink on the document is dry.
- The document has no holes, is not ripped or wrinkled, and has no articles attached to it.
- The document has no staples or other objects attached that might damage the feeder mechanism.
- The document has no folds closer than 5 mm from its edge.
- The document is not a multipart form or bound.
- The document has no rear carbon coating.
- The document has no cut out areas.

Other precautions

Do not feed photographic sheets or valuable original artwork into the Automatic Document Feeder; misfeeding a document may result in accidental wrinkling or damage.

When you are scanning high-quality color or halftone documents, it is recommended you open the Automatic Document Feeder and scan documents individually.

2. Insert the paper stack into the Automatic Document Feeder until it meets resistance. Make sure that the side you want to scan is facing up. Then move the right edge guide so it is flush with the right edge of your paper.

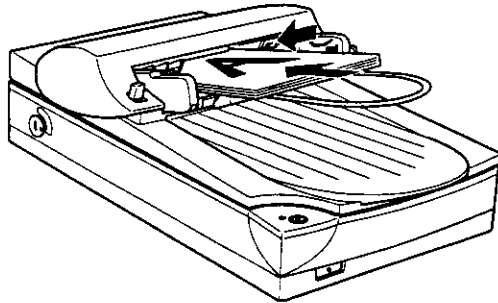

Documents are output into the lower tray after scanning is finished.

Note:

If you come across the following problems, see the respective pages for further information:

- When paper is jammed, see page ?-?.*
- When a scanned image has vertical lines, see page ?-?.*

L

**Paprika-U
Rev. B**

A5 size
5/25/98

CHAP3.FM
Pass 0

Proof Sign-off:
<antoname>
<leadername>
<editorname>

5. Attach the Automatic Document Feeder's connector to the scanner's option interface.

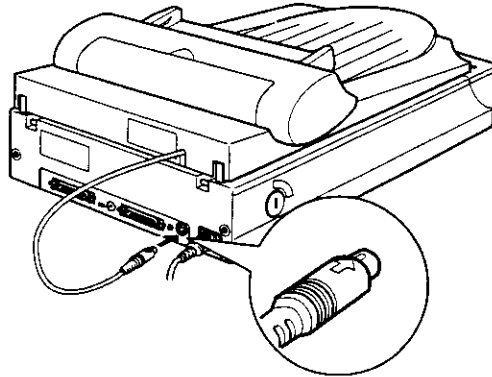

6. Attach the paper support to the Automatic Document Feeder.

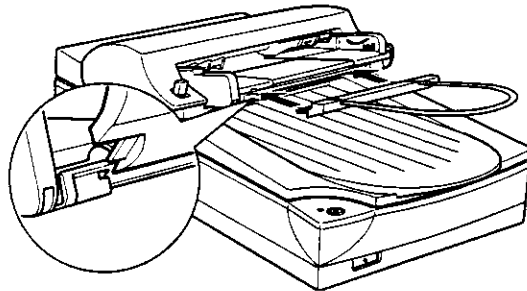

Note:

After you install the Auto Document Feeder, be sure to select Auto Document Feeder (ADF) in the Document Source settings in EPSON TWAIN. See EPSON Scan !II & EPSON TWAIN User's Guide for further information.

Using the Automatic Document Feeder

The Automatic Document Feeder (B81314*) allows you to automatically load multiple-page documents into your scanner. This document feeder is particularly useful for OCR (optical character recognition) scanning, or for creating an image database.

Unpacking the Automatic Document Feeder

When you unpack your Automatic Document Feeder, make sure you have all the parts shown below and that none are damaged. If you find any missing or damaged items, contact your EPSON dealer immediately.

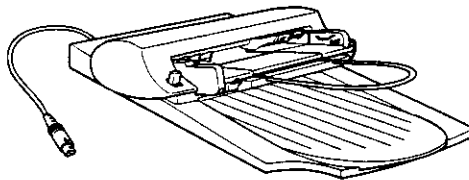

Automatic Document Feeder

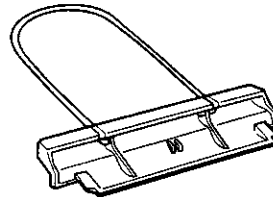

Paper support

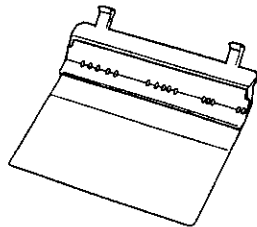

Spare paper path guide

3. Close the unit.

Note:

- Make sure the unit is completely closed. If it is not closed, an option error results and you cannot scan the document.*
- You can move and adjust the position of the 35mm film by sliding the film strips while they are in the transparency guide, so that the frames you want scan are positioned in the window.*

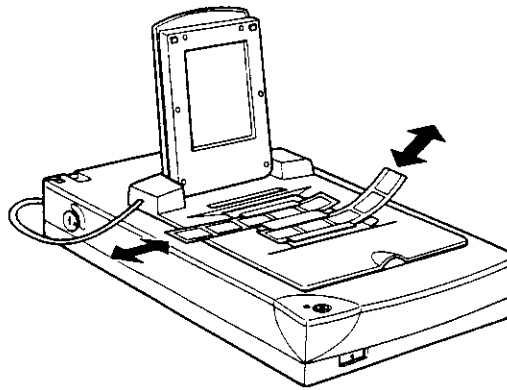

- To remove a film holder from the document table, slide it left or right then take it out of the window.*

2. Load the transparency to be scanned face down on the scanner's document table in the big window of the Film Adapter as shown below.

- If you are scanning 35 mm strip film, use the 35 mm film holder to set the film.

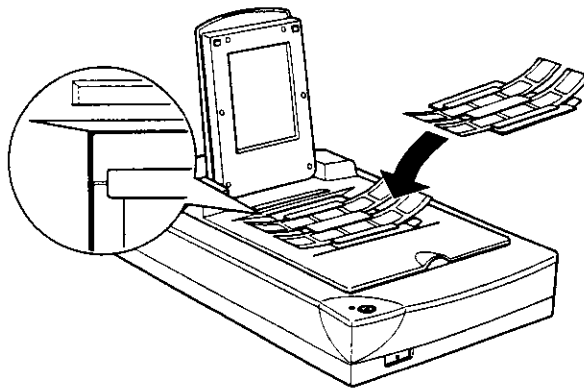

- If you are scanning slides or transparencies which will not fit in the film holders, place them directly on the document table.

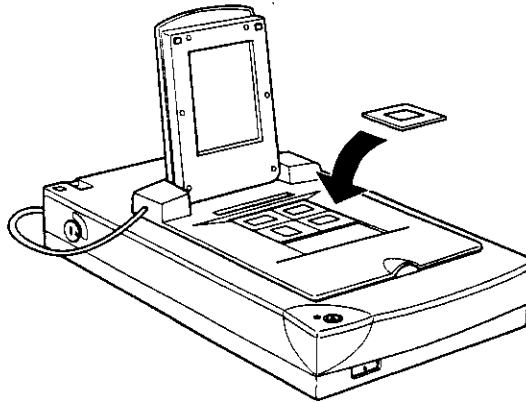

L

Paprika-U
Rev. B

A5 size
5/25/98

CHAP3.FM
Pass 0

Proof Sign-off:
<tantoname>
<leadname>
<editname>

Brownie size (6 cm x 9 cm) film

Insert film in the Brownie size film holder, base side facing down.

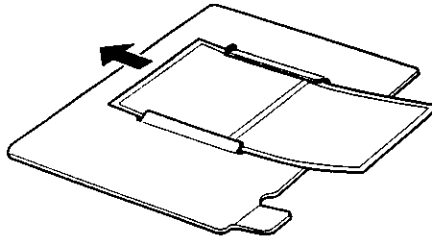

4 x 5 inches film

Insert film in the 4 x 5 inch film holder, base side facing down.

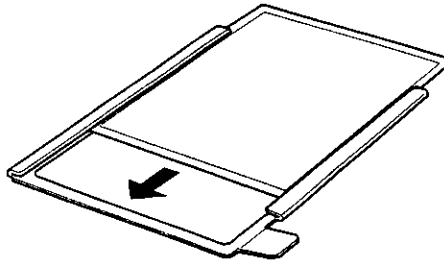

4. Connect the Film Adapter connector to the option connector on the scanner.

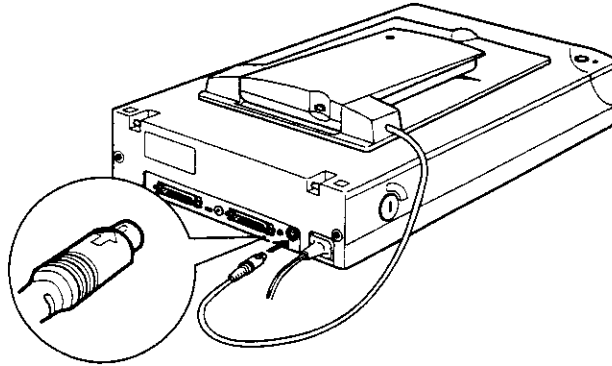

5. Turn on the scanner.
6. Turn on the Film Adapter.

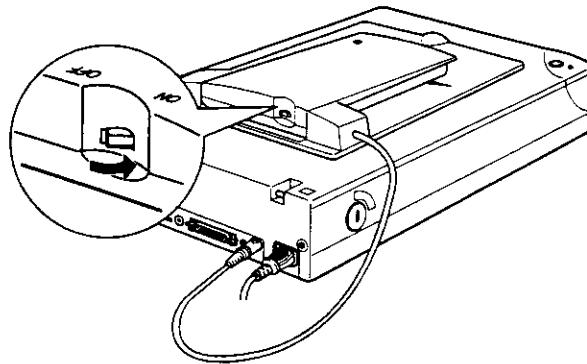

Using the Film Adapter

This Film Adapter (B81313*) is a high-quality device developed to enable you to scan negatives, transparencies, and slides—beautifully; by simply installing the unit on your scanner. The Film Adapter is small and compact so it can be attached or removed easily when you alternate scanning between transparent material and normal reflective (paper) documents.

Unpacking the Film Adapter

When you first open the package, make sure that all the following items are included and that none have been damaged during shipping. If any items are missing or damaged, contact your EPSON dealer immediately. Do not throw away the package after unpacking the Film Adapter as it can be used again to store the Film Adapter when you are not scanning transparencies.

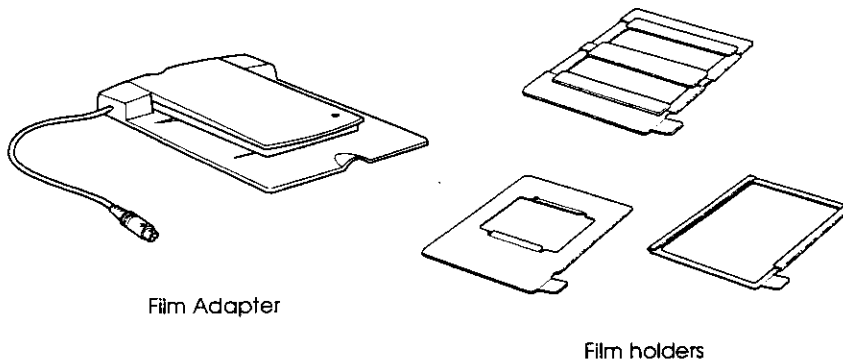

L

Paprika-U
Rev. B

A5 size
5/25/98

CHAP2.FM
Pass 0

Proof Sign-off:
M. Fujimori
<leadername>
<editorname>

Sizing Up Your System

Your scanner is sufficient for most scanning needs, but if you are not satisfied with the quality of the images on your monitor or with the speed of image processing, read this section. While it does not contain specific recommendations, it describes various possibilities for improving your scanning system. For further information, seek advice from your dealer or an experienced scanner user.

RAM and hard disk size

Scanned images use much more memory than text files, so you may need more RAM (Random Access Memory) in your computer and a larger hard disk than you have used previously.

Accelerator boards

In addition to memory, processing speed is important because large files take longer to process than small ones. Therefore, you may want to add an accelerator board to your computer.

Video cards

A video card that is sufficient for text may not be good enough for displaying graphic images, especially in color. If all your scanned images look coarse on your monitor, you may want to upgrade your video card. You will need 24-bit color, also called true color or millions of colors, to make the highest quality image reproductions.

Note:

- Make sure the document is flat against the glass surface; otherwise the image will appear fuzzy and out of focus. Also, be sure to close the document cover. This prevents interference from external light.*
 - Always keep the document table clean. See "Cleaning the Scanner" in Chapter ??.*
 - Do not leave photographs on the document table for an extended period of time as they may stick to the glass.*
 - Do not place heavy objects on top of the scanner.*
6. Start your scanner software, and follow scanning instructions in your scanner software manual.

Removing the Cover for Thick or Large Documents

For thick materials or documents that are larger than the document table, remove the document cover.

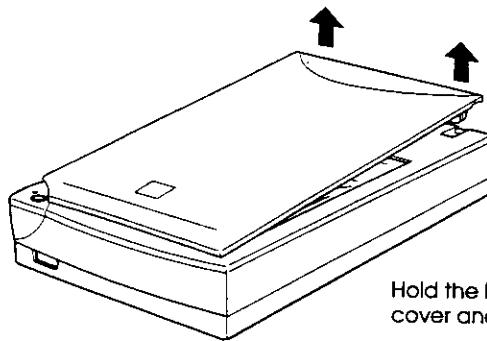

Hold the back of the document cover and lift straight up.

Placing a Document on the Scanner

Before scanning a document:

Remember to respect the rights of copyright owners. Do not scan published text or images without first checking the copyright status.

1. Turn on the scanner by pressing the Operate button. The operate light starts flashing.

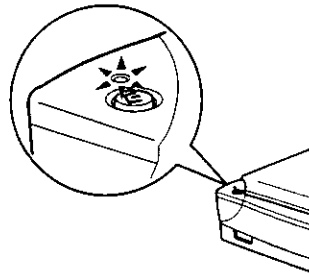

2. Turn on the computer and make sure that the scanner's operate light is on, but has stopped flashing.
3. Open the document cover.

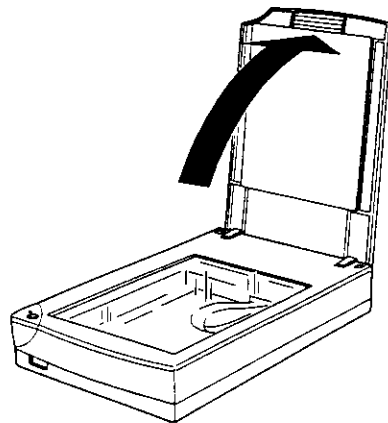

This chapter shows you how the scanner operates. The basic procedure for scanning is as follows:

1. Turn on the scanner. (Keep in mind the 'Power-on sequence' on page 1-??.)
2. Place the document or material you want to scan on the document table. (This is described in detail on page 2-?.)
3. Run the scanner software and scan. (See your scanner software manual for details on scanning.)

Lights and Buttons

The scanner has one indicator light and two buttons.

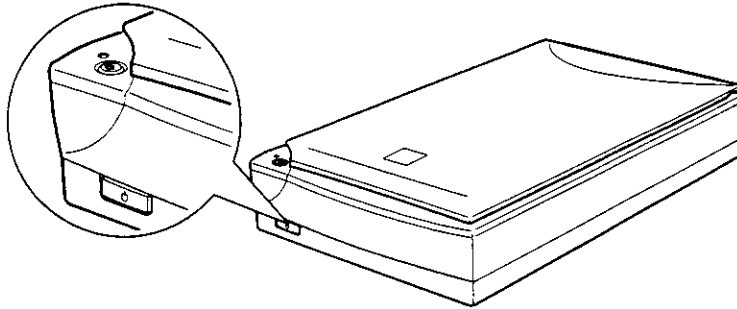

Power-off sequence

Keep the following in mind every time you turn off your computer and SCSI devices.

- When you are finished using your system, turn off your computer first, then the scanner and other SCSI devices in reverse order of the power-on sequence.
- While using your computer, do not turn off any SCSI device which has a terminator that is active (on).
- Do not turn the scanner off and back on while using your computer, otherwise the scanner may not scan properly.

Now that the connection is completed, you need to install the scanner software. See Chapter 1 of your scanner software manual.

2. Connect one end of the cable to one of the scanner SCSI connectors until the locks on both sides snap in.

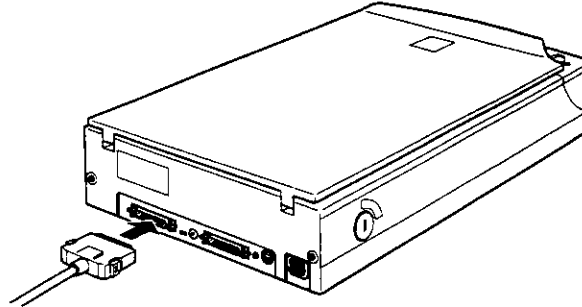
**Note:**

- To connect the scanner to a SCSI device other than the computer, the length of cable in the daisy chain must not exceed 6 meters; otherwise the system may not work properly.
- To connect the scanner to a PC using SCSI-2, the length of the cable must not exceed 3 meters.

3. Connect the other end of the cable to the SCSI port of your computer or another SCSI device.

Note:

The SCSI port of the Macintosh is the larger port with the SCSI icon over it.

4. Connect the power cables of your computer, scanner, and other external SCSI devices.

Note:

Before turning on your system, be sure to read "Power-on sequence" following.

Setting the terminator switch

The scanner has a built-in terminator, which allows SCSI devices to communicate properly with each other. You may need to change the terminator switch setting according to your computer system.

Note:
Do not use an external terminator.

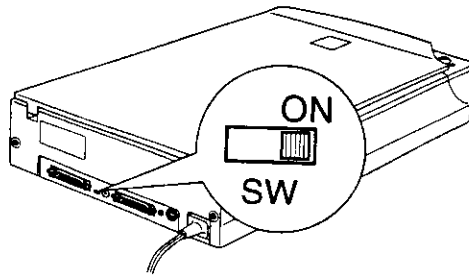

The terminator switch is located at the rear of the scanner.

Only the scanner is connected

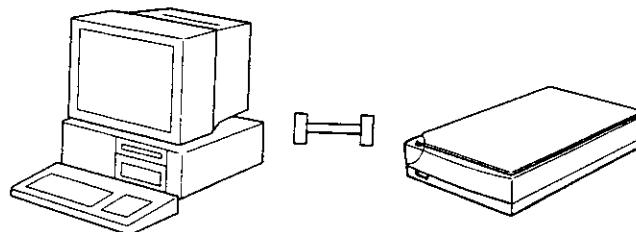

terminator on

L

Paprika-U
Rev. B

A5 size
5/26/98

CHAP1.FM
Pass 0

Proof Sign-off:
M. Fujimori
<leadname>
<editname>

Setting the SCSI ID number

The scanner's default SCSI ID number is 2.

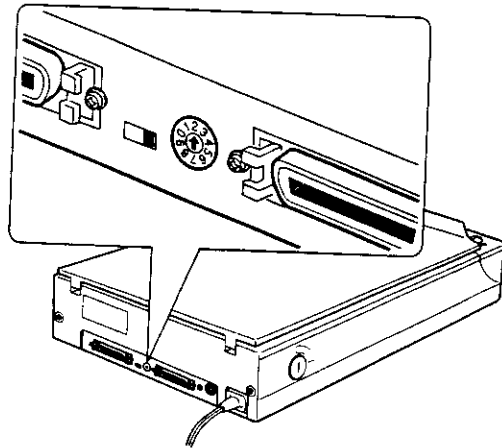

The SCSI ID rotary switch is located at the rear of the scanner.

L

**Paprika-U
Rev. B**

A5 size
5/26/98

CHAP1.FM
Pass 0

Proof Sign-off:
M. Fujimori
<leadername>
<editorname>

Connecting the Scanner to Your Computer

For PC users:

Unless your PC already has a SCSI board installed, you need to install one, along with SCSI driver software. Install the SCSI board according to the directions included with it. Also see "Installing a SCSI Interface Board" on page 1-5.

If your PC has a SCSI board up and running, connect the scanner as described in the next section.

Note:

You can install the SCSI driver that is normally included in Windows 95, 98, or NT (see your system documentation for instructions), or the driver described in the SCSI board installation documentation.

For Macintosh users:

All Macintosh computers have built-in SCSI ports; therefore you do not need to install a SCSI board in a Macintosh. Follow the directions below to connect your scanner and computer.

Understanding SCSI connections

Read the following sections to determine how to set up your SCSI devices and whether you need any optional SCSI cables.

Plugging in the Scanner

1. Make sure that the scanner is turned off. The scanner is off when the OPERATE button is not pushed in beyond the surface of the front panel.

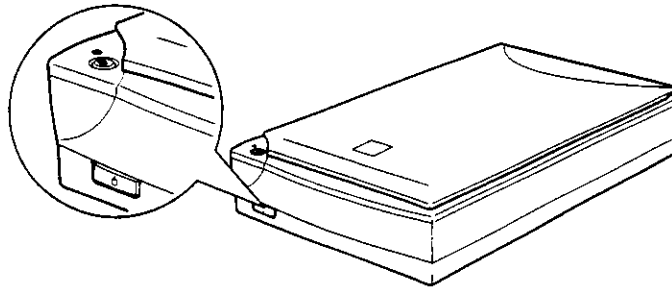

2. If the power cord is not attached to the scanner, connect it to the AC inlet on the back of the scanner, and plug the other end into a properly grounded electrical outlet.

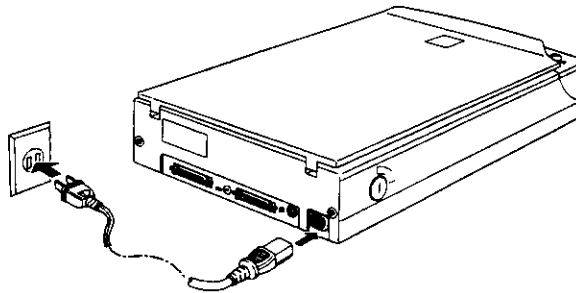
**Caution:**

It is not possible to change the scanner's voltage. If the label on the back of the scanner does not show the correct voltage for your country, contact your dealer. Do not plug in the power cord.

Installing a SCSI Interface Board (Windows Only)

Unless your PC already has a SCSI board installed, you need to install a SCSI board and SCSI software before installing the scanner driver and software applications.

If you have a Macintosh or if you already have a SCSI board installed in your PC, go to the next section.

Note:

For additional information, see the installation guide that comes with your SCSI board.

1. Turn off the computer and any peripheral devices. Unplug any power cords, then disconnect all cables from the back panel of your computer.
2. Remove the cover from your computer.



Caution:

Static electricity can damage electronic components. Discharge static electricity by touching the metal frame of your computer before handling the interface board or any of the computer's circuit boards.

3. Insert the interface board into an appropriate expansion slot, then secure it with the retaining screw.
4. Replace the computer cover and reconnect all cables.

Choosing a Place for the Scanner

Follow the guidelines below when selecting a location for your scanner:

- Place the scanner on a flat, stable surface. The scanner will not operate properly if it is on an angle.
- Place the scanner close enough to the computer for the interface cable to reach it easily.
- Place the scanner near a wall outlet where the plug can be easily unplugged.

Note for French-speaking users:

Placez l'imprimante près d'une prise de contact où la fiche peut être débranchée facilement.

- Allow some space behind the scanner for the cables, and be sure to place the scanner where you can easily unplug the power cord. Also allow sufficient space above the scanner so that you can fully raise the document cover.

Unpacking the Scanner

Your GT-7000/GT-7000 PHOTO comes shipped with CD-ROMs, which include the driver software that runs your scanner, and some additional items, depending on your scanner model.

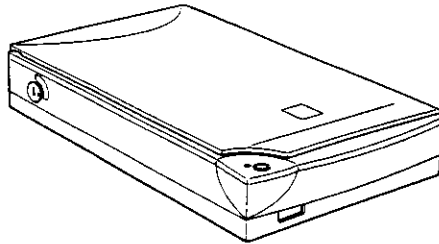

Scanner

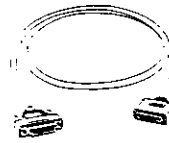

SCSI interface cable

For the CT-7000 PHOTO

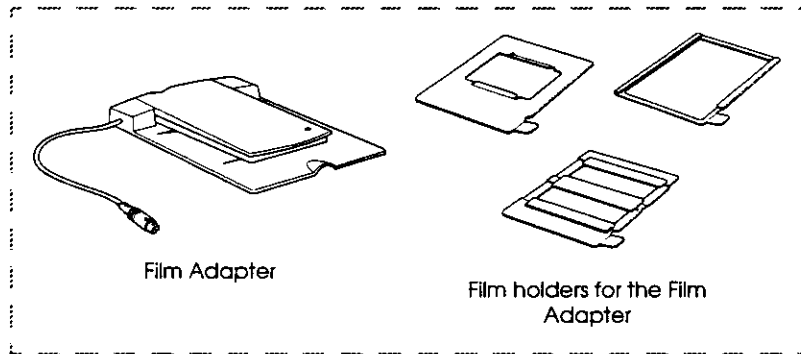

Film Adapter

Film holders for the Film Adapter

Note:

The GT-7000 PHOTO comes with the Film Adapter which is also available as an option for GT-7000.

Depending on the country of purchase, the power cord may come attached to the scanner. The shape of the AC plug also varies, so make sure the plug included is the correct shape for the electrical outlet in your country.

L

Paprika-U
Rev. B

A5 size
5/26/98

INTRO.FM
Pass 0

Proof Sign-off:
<tantoname>
<leadername>
<editomame>

- If you plan to use the scanner in Germany, observe the following:

To provide adequate short-circuit protection and over-current protection for this scanner, the building installation must be protected by a 16 Amp circuit breaker.

Note for German-speaking users:

Bei Anschluß des Scanners an die Stromversorgung muß sichergestellt werden, daß die Gebäudeinstallation mit einem 16 A-Überstromschalter abgesichert ist.

ENERGY STAR Compliance



As an ENERGY STAR Partner, EPSON has determined that this product meets the ENERGY STAR guidelines for energy efficiency.

The International ENERGY STAR Office Equipment Program is a voluntary partnership with the computer and office equipment industry to promote the introduction of energy-efficient personal computers, monitors, printers, fax machines, copiers, and scanners, in an effort to reduce air pollution caused by power generation.

- Automatic Document Feeder which enables continuous sheets scanning is available as an option.

Options

The following optional items are available to expand the versatility of your scanner. For detailed information on the use of these options, see Chapter X of this guide.

Automatic Document Feeder (B81314*)

Designed primarily for optional character recognition (OCR) scanning, the Automatic Document Feeder allows you to scan up to 20 pages automatically, then use them in a word processing program, as if you had typed the text yourself.

Film Adapter (B81313*)

Allows you to scan transparent materials; primarily 35 mm slides and filmstrips. The Film Adapter's reading area allows you to scan film sized up to 4 × 5 inches.

Note:

The asterisk is a substitute for the last digit of the product number, which varies by country.

Warnings, Cautions, and Notes



Warnings must be followed carefully to avoid bodily injury.



Cautions must be observed to avoid damage to your equipment.

Notes contain important information and useful tips on the operation of your scanner.

L

Paprika-U
Rev. B

A5 size
5/26/98

PAPR-U.TOC
Pass 0

Proof Sign-off:
<tantoname>
<leadername>
<editorname>

Chapter 2 Using Your Scanner

Lights and Buttons	2-2
Placing a Document on the Scanner	2-4
Removing the Cover for Thick or Large Documents	2-6
Sizing Up Your System	2-8
RAM and hard disk size	2-8
Accelerator boards	2-8
Video cards	2-8
Monitors	2-9
File compression software	2-9

Chapter 3 Options

Using the Film Adapter	3-2
Unpacking the Film Adapter	3-2
Using the Film Adapter	3-3
Film Holders	3-5
Loading transparencies	3-7
Scanning normal (reflective) documents	3-11
Using the Automatic Document Feeder	3-12
Unpacking the Automatic Document Feeder	3-12
Installing the Automatic Document Feeder	3-13
Loading paper into your Automatic Document Feeder ..	3-15
Loading documents manually	3-17
Document specifications	3-17

Chapter 4 Maintenance and Troubleshooting

Maintenance	4-2
Cleaning the scanner	4-2
Replacing the fluorescent lamps	4-3
Cleaning or replacing the paper path guide	4-3
Transporting the Scanner	4-8

L

Paprika-U
Rev. B

A5 size
5/26/98

FRONT.FM
Pass 0

Proof Sign-off:
<tantoname>
<leadername>
<editorname>

Declaration of Conformity

Manufacturer: SEIKO EPSON CORPORATION
Address: 3-5, Owa 3-chome, Suwa-shi,
Nagano-ken 392 Japan

Representative: EPSON EUROPE B.V.
Address: Prof. J. H. Bavincklaan 5 1183
AT Amstelveen
The Netherlands

Declares that the Product:

Product Name: Image Scanner
Model: G680A/G680B

Conforms to the following Directive(s) and Norm(s):

Directive 89/336/EEC:

EN 55022 Class B
EN 61000-3-2
EN 61000-3-3
EN 50082-1
IEC 801-2
IEC 801-3
IEC 801-4

Directive 73/23/EEC:

EN 60950

August, 1998

Y. Ishii
President of EPSON EUROPE B.V.

