

Proof Sign-off:
<antname> _____
<leadname> _____
<editname> _____

Sun-E+
Rre Rev. C

A5 size
8/5/98

Front.fm
Pass 0

R

FCC/MELLON

SEP 10 1998

EPSON®

24-Pin Dot Matrix Printer

LQ-2180

Epson.eps

LQ-2180.eps

All rights reserved. No part of this publication may be reproduced, stored in a retrieval system, or transmitted in any form or by any means, electronic, mechanical, photocopying, recording, or otherwise, without the prior written permission of SEIKO EPSON CORPORATION. The information contained herein is designed only for use with this EPSON printer. EPSON is not responsible for any use of this information as applied to other printers.

Neither SEIKO EPSON CORPORATION nor its affiliates shall be liable to the purchaser of this product or third parties for damages, losses, costs, or expenses incurred by the purchaser or third parties as a result of: accident, misuse, or abuse of this product or unauthorized modifications, repairs, or alterations to this product, or (excluding the U.S.) failure to strictly comply with SEIKO EPSON CORPORATION's operating and maintenance instructions.

SEIKO EPSON CORPORATION shall not be liable for any damages or problems arising from the use of any options or any consumable products other than those designated as Original EPSON Products or EPSON Approved Products by SEIKO EPSON CORPORATION.

EPSON and EPSON ESC/P are registered trademarks and EPSON ESC/P2 is a trademark of SEIKO EPSON CORPORATION.

Microsoft and Windows are registered trademarks of Microsoft Corporation.

IBM is a registered trademark of International Business Machines Corporation.

General Notice: Other product names used herein are for identification purposes only and may be trademarks of their respective owners. EPSON disclaims any and all rights in those marks.

Copyright © 1998 by SEIKO EPSON CORPORATION, Nagano, Japan.

 Printed on Recycled Paper.

User's Guide

**FCC Compliance Statement
For United States Users**

This equipment has been tested and found to comply with the limits for a Class B digital device, pursuant to Part 15 of the FCC Rules. These limits are designed to provide reasonable protection against harmful interference in a residential installation. This equipment generates, uses, and can radiate radio frequency energy and, if not installed and used in accordance with the instructions, may cause harmful interference to radio or television reception. However, there is no guarantee that interference will not occur in a particular installation. If this equipment does cause interference to radio and television reception, which can be determined by turning the equipment off and on, the user is encouraged to try to correct the interference by one or more of the following measures.

- Reorient or relocate the receiving antenna
- Increase the separation between the equipment and receiver
- Connect the equipment into an outlet on a circuit different from that to which the receiver is connected
- Consult the dealer or an experienced radio/TV technician for help.

WARNING

The connection of a non-shielded equipment interface cable to this equipment will invalidate the FCC Certification of this device and may cause interference levels which exceed the limits established by the FCC for this equipment. It is the responsibility of the user to obtain and use a shielded equipment interface cable with this device. If this equipment has more than one interface connector, do not leave cables connected to unused interfaces.

Changes or modifications not expressly approved by the manufacturer could void the user's authority to operate the equipment.

For Canadian Users

This Class B digital apparatus meets all requirements of the Canadian Interference-Causing Equipment Regulations.

Cet appareil numérique de la classe B respecte toutes les exigences du Règlement sur le matériel brouilleur du Canada.

Declaration of Conformity

According to ISO/IEC Guide 22 and EN 45014

Manufacturer: SEIKO EPSON CORPORATION
Address: 3-5, Owa 3-chome, Suwa-shi, Nagano-ken 392 Japan
Representative: EPSON EUROPE B.V.
Address: Prof. J. H. Bavincklaan 5 1183 AT Amstelveen The Netherlands

Declares that the Product:
Product Name: Dot Matrix Printer
Model: ~~P910B~~ P910C

Conforms to the following Directive(s) and Norm(s):

Directive 73/23/EEC:
EN 60950
Directive 89/336/EEC:
EN 55022 Class B
EN 61000-3-2
EN 61000-3-3
EN 50082-1
IEC 801-2
IEC 801-3
IEC 801-4

November 1998
H. Horiuchi
President of EPSON EUROPE B.V.

Proof Sign-off: _____
<stantname> _____
<leademame> _____
<editomame> _____

Sun-E+
Pre Rev. C

A5 size
8/5/98

Sun_E+.TOC
Pass 0

R

Contents

Getting to Know Your Printer

Easy-to-Use Features	2
Available Paper Paths	3
Printing on continuous paper	4
Printing on single sheets	8
Options	10
Ribbon Cartridge	10
Important Safety Instructions	11
Print Head Caution Symbol	12
ENERGY STAR Compliance	13
For United Kingdom Users	13
Use of options	13
Safety information	14
How To Use Your Manuals	15
Warnings, Cautions, and Notes	15

Chapter 1 Setting Up the Printer

Unpacking the Printer	1-2
Choosing a Place for the Printer	1-4
Positioning the continuous paper supply	1-5
Installing or Replacing the Ribbon Cartridge	1-6
Attaching the Paper Guide and Paper Separator	1-11
Plugging In the Printer	1-13
Connecting the Printer to Your Computer	1-14
Installing the Printer Software	1-15
Installing in Windows 95, 98, and NT 4.0	1-16
Installing in Windows 3.1 and NT 3.5x	1-17
For DOS programs	1-18

Chapter 2 Printing on Continuous Paper

Setting the Paper Release Lever	2-2
Setting the Paper Thickness Lever	2-3
Loading Multi-Part Forms	2-5
Loading Continuous Paper With Labels	2-5
Removing continuous paper with labels	2-7
Using the Front Push Tractor	2-8
Installing the tractor in the front push position	2-8
Loading paper onto the front push tractor	2-9
Removing the printed document from the front push tractor	2-13
Removing the front push tractor	2-15
Using the Rear Push Tractor	2-16
Loading paper onto the rear push tractor	2-16
Removing the printed document from the rear push tractor	2-20
Using the Tractor in the Pull Position	2-21
Installing the tractor in the pull position	2-22
Loading paper onto the pull tractor	2-23
Removing paper from the pull tractor	2-29
Using two tractors in a push and pull combination	2-29
Removing the pull tractor	2-32
Switching Between Printing on Continuous Paper and Printing on Single Sheets	2-34
Switching to printing on single sheets	2-34
Switching to printing on continuous paper	2-35
Adjusting the Top-of-Form Position	2-36
Advancing the Paper to the Tear-Off Edge	2-39
Using the Tear Off/Bin button	2-39
Advancing paper to the tear-off position automatically ..	2-40
Adjusting the tear-off position	2-40

Chapter 3 Printing on Single Sheets

Using Single Sheets	3-2
Available paper types and paper slots	3-2
Loading single-sheet multi-part forms	3-4

Loading envelopes	3-6
Loading postcards	3-7
Loading Single Sheets in the Top Paper Slot.....	3-8
Loading Single Sheets in the Front Paper Slot	3-10

Chapter 4 Using the Printer Software

About Your Printer Software.....	4-2
Using the Printer Driver With Windows 95/98	4-3
Accessing the printer driver from Windows applications	4-3
Accessing the printer driver from the Start menu.....	4-5
Printer driver settings overview.....	4-5
Using the Printer Driver With Windows 3.1.....	4-9
Accessing the printer driver from Windows applications	4-9
Accessing the printer driver from the Control Panel	4-10
Printer driver settings overview.....	4-11
Using the Printer Driver With Windows NT 4.0	4-13
Accessing the printer driver from Windows applications	4-13
Accessing the printer driver from the Start menu.....	4-15
Printer driver settings overview.....	4-15
Using the Printer Driver With Windows NT 3.5x	4-19
Accessing the printer driver from Windows applications	4-19
Accessing the printer driver from the Control Panel	4-21
Printer driver settings overview.....	4-22
Using the EPSON Remote! Utility	4-24
Installing EPSON Remote!	4-24
Accessing EPSON Remote!.....	4-24

Chapter 5 Changing Printer Settings From the Printer's Control Panel

Selecting a Built-In Font and Pitch	5-2
About Your Printer's Default Settings	5-4
Changing default settings.....	5-9

Chapter 6 Using EPSON Status Monitor 2

About the EPSON Status Monitor 2 Utility	6-2
Installing EPSON Status Monitor 2	6-3
Accessing EPSON Status Monitor 2	6-4
Checking Printer Status Information	6-4
Using the EPSON Status Monitor 2 window	6-4
Using the Printer Status window	6-9
Making Monitoring Preference Settings	6-10
Turning on background monitoring	6-11
Using the background monitoring icon	6-12

Chapter 7 Troubleshooting

Using the Error Indicators	7-2
Problems and Solutions	7-4
Power supply problems	7-5
Single-sheet paper loading or feeding problems	7-6
Continuous paper loading or feeding problems	7-8
Wrong top-of-form position	7-9
Wrong tear-off position	7-10
Printing or printout quality problems	7-11
Clearing Paper Jams	7-16
Aligning Vertical Lines in Your Printout	7-17
Printing a Self Test	7-18
Printing a Hex Dump	7-19

Appendix A Enhancing Your Printer With Options

Options	A-2
Paper handling options	A-2
Optional interface cards	A-3
Using the Optional Cut-Sheet Feeders	A-4
Installing the high-capacity or double-bin cut-sheet feeder	A-4
Loading paper in the high-capacity cut-sheet feeder	A-6
Selecting the paper source (bin 1 or bin 2)	A-10

Proof Sign-off:
<antoname> _____
<leadename> _____
<editname> _____

Sun-E+
Pre Rev. C

A5 size
8/5/98

Sun_E+.TOC
Pass 0

R

Switching between continuous paper and single-sheet paper in the cut-sheet feeder	A-11
Using the Roll Paper Holder	A-12
Assembling the roll paper holder	A-12
Installing the roll paper holder.....	A-13
Loading roll paper	A-14
Removing roll paper	A-16
Installing an Interface Card	A-17
Using the C82305* or C82306* serial interface card	A-18

Appendix B *Cleaning and Transporting the Printer*

Cleaning the Printer	B-2
Transporting the Printer.....	B-3

Appendix C *Specifications*

Printer Specifications	C-2
Mechanical.....	C-2
Electrical.....	C-5
Environmental	C-5
Paper.....	C-6
Paper alignment	C-9
Printable area	C-10
Safety approvals	C-13
CE marking	C-13
Command Lists	C-14
EPSON ESC/P2 control codes	C-14
IBM 2391 Plus emulation control codes	C-17
Character Tables	C-19
International character sets for the Italic table	C-29

Appendix D Customer Support Information

Contacting Customer Support	D-2
For North American Users	D-2
For United Kingdom and the Republic of Ireland Users	D-4
Enquiry Desk	D-4
Customer Support	D-4
Faxon EPSON	D-5
EPtec - Bulletin Board Service for latest drivers and utilities	D-5
World Wide Web	D-5
For Australian Users	D-6
EPSON FAXBACK	D-6
EPSON Bulletin Board System	D-6
Internet URL http://www.epson.com.au	D-6
Your dealer	D-6
EPSON Helpdesk	D-7
For Singapore Users	D-7
For Hong Kong Users	D-7
Internet home page	D-8
Electronic bulletin board system	D-8
Technical support hotline	D-8
For Philippines Users	D-8

Glossary

Index

Proof Sign-off: _____
<antoname> _____
<leadename> _____
<editname> _____

Sun-E+
Pre Rev. C

A5 size
8/5/98

Intro.fm
Pass 0

R

Getting to Know Your Printer

Your EPSON® LQ-2180 24-pin dot matrix printer provides high-quality printing and great performance in a compact design. Features include:

- a variety of paper paths to suit your printing needs
- the ability to handle a wide range of paper types, including continuous paper, multi-part forms with one original plus up to five copies, labels, single sheets, envelopes, and postcards
- high-speed printing of up to 480 characters per second at 10 characters per inch

Your printer also comes with printer driver software, the EPSON Status Monitor 2 utility for Microsoft® Windows® 95 that lets you check the status of your printer quickly and easily, and other software. In addition, several options are available to help suit your individual needs.

Easy-to-Use Features

This section highlights some easy-to-use features that you'll find helpful.

- Use the **tear-off feature** to save paper.

If you load paper on the front or rear push tractor, you can use the tear-off feature to advance your continuous paper to the printer's tear-off edge when you finish printing. Then you can easily tear off the printed sheets and save the paper normally lost between documents. For more information, see Chapter 2.

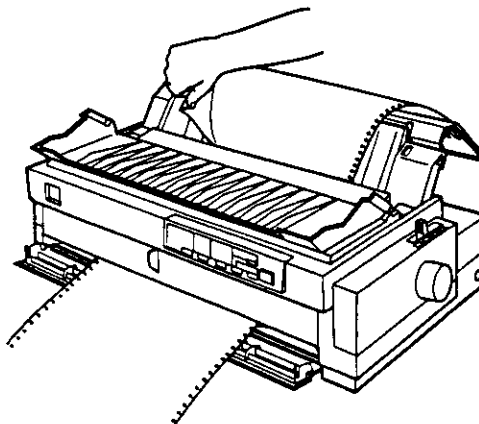

- Use the **paper release lever** to change the paper path without removing the paper.

Using the paper release lever, you can easily switch to printing on single sheets without removing the continuous paper loaded on the front or rear push tractor. You can also easily switch to printing on continuous paper on a different tractor. For more information, see Chapter 2.

1-1.eps

Proof Sign-off:
<antname> _____
<leadname> _____
<editname> _____

Sun-E+ Pre Rev. C

A5 size
8/5/98

Intro.fm
Pass 0

R

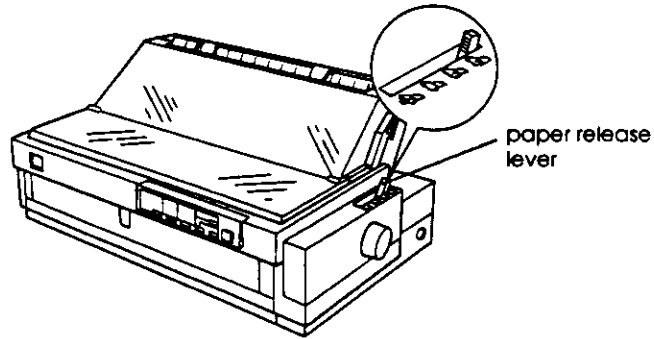

2-1.eps

- Use the **micro adjust feature** to adjust the top-of-form and tear-off positions. See the Glossary for explanations of the top-of-form and tear-off positions.

The micro adjust feature allows you to move the paper forward or backward in 1/180-inch increments so that you can make precise adjustments to the top-of-form and tear-off positions. For more information, see Chapter 2.

Available Paper Paths

Your printer provides a variety of paper paths for printing on continuous and single-sheet paper. As described below, paper can be fed into the printer from the top, front, bottom, or rear. You select the paper path that best suits your current printing needs.

Printing on continuous paper

You can choose from three tractor positions (front push, rear push, and pull) and three paper entry slots (front, rear, and bottom) for continuous paper printing. This section helps you determine which paper paths and tractor positions are best for your continuous paper printing needs. See the appropriate sections in Chapter 2 for tractor installation and paper loading instructions.

Using a push tractor

If you often need to tear off sheets of continuous paper (for example, if you are printing purchase orders or sales slips), it is best to use a push tractor. This allows you to use the printer's tear-off edge to easily tear off printed sheets of continuous paper at the perforation. Also, when continuous paper is loaded on a push tractor, you can load single sheets of paper from the paper guide without removing the continuous paper.

There are two push tractor positions: front and rear. The tractors are installed in the front push and rear push positions when the printer is shipped. See the table below for details about the push positions and the corresponding paper-feeding paths.

Note:

- The tractor in the rear push position cannot be removed.*

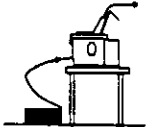
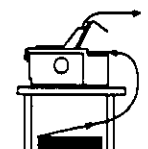
Tractor position	Description
 front push	To use this tractor, load paper in the front slot. If you print on thick paper such as multi-part forms or continuous paper with labels, load the paper in the front paper slot because the paper path from this slot is almost straight. This reduces the chance of paper jams.
 rear push	To use this tractor, load paper in the rear slot. Note: <i>Because thick multi-part forms require a straight paper path, load them in the front slot.</i> Caution: <i>Do not load continuous paper with labels in the rear slot. If you load continuous paper with labels in the rear slot, the labels may come off their backing sheet inside the printer and cause a paper jam.</i>

g2-8aa1.eps

g2-8aa4.eps

Using a pull tractor

If you often print on thick or heavy continuous paper, such as multi-part forms or continuous paper with labels, use a tractor in the pull position. The pull tractor provides the best paper jam prevention, and allows you to load continuous paper from the front, rear, or bottom of the printer. However, you cannot use the tear-off feature with the pull tractor.

Note:

If you plan to use a pull tractor, you can remove the tractor from the front push position and install it in the pull position, or you can purchase the optional pull tractor (C80032) and install it in the pull position. See Chapter 2 for instructions.*

As shown in the table below, three paper entry slots are available for use with the pull tractor: front, bottom, and rear.

Paper slot	Description
------------	-------------

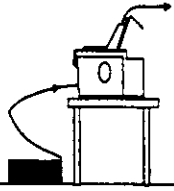
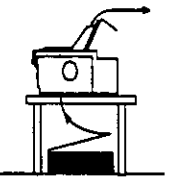
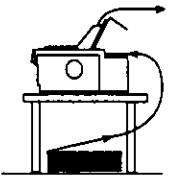
 <p style="text-align: center;">front</p>	<p>If you print on thick paper such as multi-part forms or continuous paper with labels, load it using the front paper slot because the paper path from this slot is almost straight. This reduces the chance of paper jams.</p>
 <p style="text-align: center;">bottom</p>	<p>Because the bottom paper slot has the straightest paper path, it is ideal for printing on thick paper, such as multi-part forms or continuous paper with labels.</p> <p>Note: When loading paper in the bottom slot, be sure to use a printer stand with an opening large enough so that the paper can feed through it without obstruction.</p>
 <p style="text-align: center;">rear</p>	<p>You can also load continuous paper onto the pull tractor using the rear slot.</p> <p>Note: Because thick multi-part forms require a straight paper path, load them in the front slot.</p> <p>Caution: Do not load continuous paper with labels in the rear slot. If you load continuous paper with labels in the rear slot, the labels may come off their backing sheet inside the printer and cause a paper jam.</p>

g2-8aa1.eps

g2-8aa2.eps

g2-8aa4.eps

Using the push and pull tractors in combination

To improve continuous paper feeding and reduce paper jams, you can use two tractors at the same time. This is especially helpful for printing on continuous pre-printed forms, multi-part forms, or labels, and for printing high quality graphics. When using two tractors in combination, you can load paper in the front paper slot onto the front push tractor and the pull tractor, or load paper in the rear paper slot onto the rear push tractor and the pull tractor.

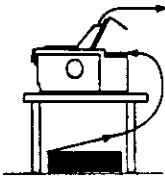
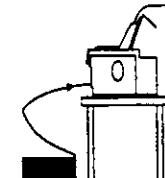
Combination	Description
 rear push and pull	<p>To use the rear push tractor with the pull tractor, you need to remove the standard tractor that comes in the front push position and install it in the pull position.</p> <p>Note: <i>Because thick multi-part forms require a straight paper path, load them in the front slot.</i></p> <p>Caution: <i>Do not load continuous paper with labels onto the rear push tractor even when it is used in combination with the pull tractor. If you load continuous paper with labels onto the rear push/pull tractor, the labels may come off their backing sheet inside the printer and cause a paper jam.</i></p>
 front push and pull	<p>To use the front push tractor with the pull tractor, you need to purchase the optional pull tractor (C80032*) and install it in the pull position.</p>

Note:
For more information on using two tractors in a push and pull combination, see page 2-29.

g2-8aa4.eps
g2-8aa1.eps



Printing on single sheets

As shown below, your printer has two paper entry slots for printing on single sheets: top and front. When continuous paper is loaded on the front or rear push tractor, you can load single sheets in the top or front slot without removing the continuous paper.

This section helps you determine which paper slot best suits your single-sheet printing needs. See Chapter 3 for paper loading instructions.

Loading paper in the top slot

You can load ordinary single sheets, single-sheet multi-part forms, envelopes, or postcards in the top slot.

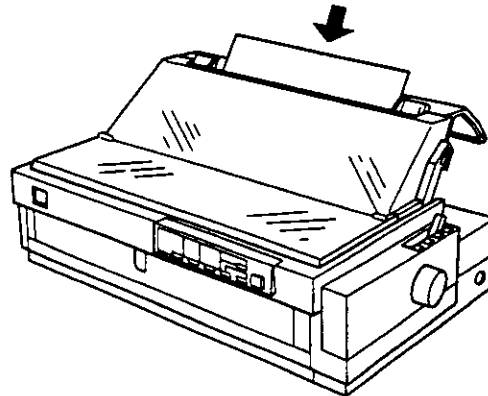

Note:

Load envelopes only in the top slot.

2-9n.eps

Proof Sign-off: _____
<stantname> _____
<leadename> _____
<editname> _____

Sun-E+ Pre Rev. C

A5 size
8/5/98

Intro.fm
Pass 0

R

Loading paper in the front slot

You can load ordinary single sheets, single-sheet multi-part forms, or postcards in the front slot.

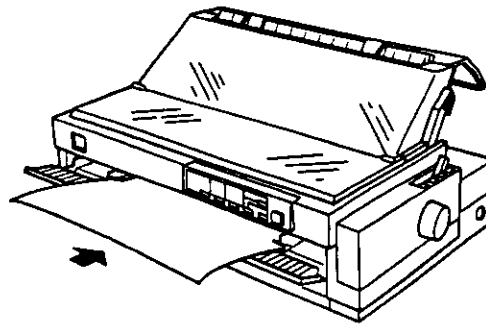

2-12.eps

Note:

Always use the front paper slot to load single-sheet multi-part forms that are bound by line glueing only at the side.

L

Sun-E+
Pre Rev. C

A5 size
8/5/98

Intro.fm
Pass 0

Proof Sign-off:
<antoname> _____
<leadename> _____
<editname> _____

Options

Your printer comes with everything necessary to print on continuous paper and single sheets using a variety of paper paths. By adding options, such as a cut-sheet feeder, pull tractor unit, or roll paper holder, you can further expand your printer's versatility. Optional interface cards are also available to supplement your printer's built-in parallel interface. For more information on options for your printer, see Appendix A, "Enhancing Your Printer With Options."

Ribbon Cartridge

Your printer uses the following ribbon cartridge:

EPSON black ribbon cartridge S015086

When printing becomes faint, you need to replace the ribbon cartridge. Genuine EPSON ribbon cartridges are designed and manufactured to work properly with your EPSON printer. They ensure proper operation and long life of the print head and other printer parts.

To replace a used ribbon cartridge, follow the instructions under "Installing or Replacing the Ribbon Cartridge" on page 1-6.

Important Safety Instructions

Read all of these instructions and save them for later reference.
Follow all warnings and instructions marked on the printer.

- Do not place the printer on an unstable surface or near a radiator or heat source.
- Place the printer on a flat surface. The printer will not operate properly if it is tilted or at an angle.
- Do not block or cover the openings in the printer's cabinet. Do not insert objects through the slots.
- Use only the type of power source indicated on the printer's label.
- Connect all equipment to properly grounded power outlets. Avoid using outlets on the same circuit as photocopiers or air control systems that regularly switch on and off.
- Do not use a damaged or frayed power cord.
- If you use an extension cord with the printer, make sure the total ampere rating of all devices plugged into the extension cord does not exceed the cord's ampere rating. Also, make sure the total of all devices plugged into the wall outlet does not exceed the wall outlet's ampere rating.
- Unplug the printer before cleaning, and clean it with a damp cloth only.
- Do not spill liquid on the printer.
- Except as specifically explained in this guide, do not attempt to service the printer yourself.

- Unplug the printer and refer servicing to qualified service personnel under the following conditions:

If the power cord or plug is damaged; if liquid has entered the printer; if the printer has been dropped or the cabinet damaged; or if the printer does not operate normally or exhibits a distinct change in performance. Adjust only those controls that are covered by the operating instructions.

-  Printer parts marked with this symbol may be hot. Turn off the printer and let it cool for a few minutes before you touch any printer part marked with this symbol.
- If you plan to use the printer in Germany, observe the following:

To provide adequate short-circuit protection and over-current protection for this printer, the building installation must be protected by a 16 Amp circuit breaker.

Note for German-speaking users:

Bei Anschluß des Druckers an die Stromversorgung muß sichergestellt werden, daß die Gebäudeinstallation mit einem 16 A-Überstromschalter abgesichert ist.

Print Head Caution Symbol



The symbol on the print head indicates that this part may be hot. Never touch the print head just after the printer has been used. Let the print head cool for a few minutes before touching it.

Proof Sign-off:
<stantname>
<leadname>
<editname>

Sun-E+
Pre Rev. C

A5 size
8/5/98

Intro.fm
Pass 0

R

ENERGY STAR Compliance



As an ENERGY STAR Partner, EPSON has determined that this product meets the ENERGY STAR guidelines for energy efficiency.

The International ENERGY STAR Office Equipment program is a voluntary partnership with the computer and office equipment industry to promote the introduction of energy-efficient personal computers, monitors, printers, fax machines, and copiers in an effort to reduce air pollution caused by power generation.

For United Kingdom Users

Use of options

Epson (UK) Limited shall not be liable against any damages or problems arising from the use of any options or consumable products other than those designated as Original EPSON Products or EPSON Approved Products by Epson (UK) Limited.

Safety Information



Warning: This appliance must be earthed. Refer to rating plate for voltage and check that the appliance voltage corresponds to the supply voltage.

Important: The wires in the mains lead fitted to this appliance are coloured in accordance with the following code:

Green and yellow — Earth
Blue — Neutral
Brown — Live

If you have to fit a plug:

As the colours of the mains lead of this appliance may not match coloured markings used to identify the terminals in a plug, please proceed as follows:

The green and yellow wire must be connected to the terminal in the plug which is marked with the letter E or the Earth symbol (\perp).

The blue wire must be connected to the terminal in the plug marked with the letter N.

The brown wire must be connected to the terminal in the plug marked with the letter L.

If damage occurs to the plug, replace the cord set or consult a qualified electrician.

Replace fuses only with a fuse of the correct size and rating.

Proof Sign-off:
<antoname>
<leadename>
<editname>

=====
=====
=====

Sun-E+
Pre Rev. C

A5 size
8/5/98

Intro.fm
Pass 0

R

How To Use Your Manuals

This *User's Guide* provides detailed information on setting up and using your printer. The *Quick Reference Guide* that also comes with the printer summarizes basic information on how to use the printer.

Warnings, Cautions, and Notes

This guide uses the following conventions:



Warnings must be followed to avoid bodily injury.



Cautions must be observed to avoid damage to your equipment.

Notes contain important information and useful tips on the operation of your printer.

L

Sun-E+
Pre Rev. C

A5 size
8/5/98

Intro.fm
Pass 0

Proof Sign-off:
<antoname>
<leadename>
<editname>

Chapter 1

Setting Up the Printer

1

Unpacking the Printer	1-2
Choosing a Place for the Printer	1-4
Positioning the continuous paper supply	1-5
Installing or Replacing the Ribbon Cartridge	1-6
Attaching the Paper Guide and Paper Separator	1-11
Plugging In the Printer	1-13
Connecting the Printer to Your Computer	1-14
Installing the Printer Software	1-15
Installing in Windows 95, 98, and NT 4.0	1-16
Installing in Windows 3.1 and NT 3.5x	1-17
For DOS programs	1-18

Unpacking the Printer

Besides this guide, your printer box should include EPSON printer software disks, a Notice Sheet, and the following items:

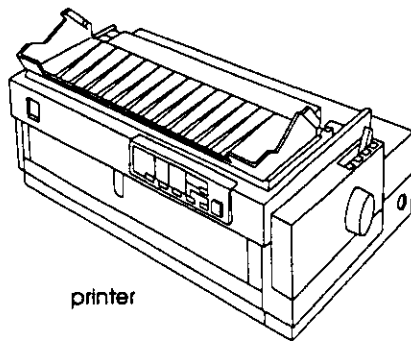

printer

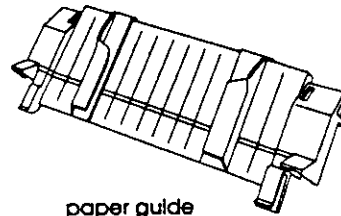

paper guide

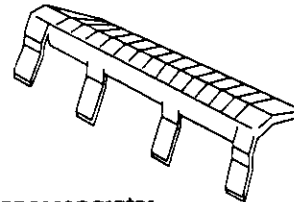

paper separator

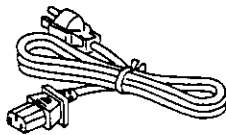

power cord

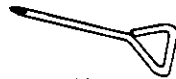

screwdriver

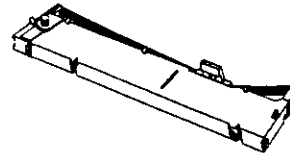

ribbon cartridge

New.eps

Note:

Depending on your printer model, the power cord may be permanently attached to the printer. Also, the shape of the power cord plug varies depending on the country in which you bought your printer; be sure the plug you have is the right one for your location.

Proof Sign-off:
<stantname>
<leadname>
<editname>

Sun-E+
Pre Rev. C

A5 size
8/5/98

Chap1.fm
Pass 0

R



Caution:

There are several models of the printer designed for different voltages, and it is not possible to adjust the printer for use with another voltage. If the label on the back of the printer does not show the correct voltage for your country, contact your dealer.

1

You must remove all protective materials packed around and inside your printer before you set it up and turn on the power. Follow the directions on the Notice Sheet (packed with the printer) to remove these materials. A screwdriver has been provided for removing the transportation screw.

Save all packing and protective materials, including the transportation screw and the protective locking clips on the paper tension unit, in case you need to ship the printer in the future. It should always be transported in its original packaging or equivalent materials.

Choosing a Place for the Printer

Follow the guidelines below when selecting a location for your printer.

- Place the printer on a flat, stable surface. The printer will not operate properly if it is tilted or at an angle.
- Place the printer where you can easily connect it to a network interface cable, if necessary.
- Leave adequate room around the printer for easy operation and maintenance.
- Avoid using or storing the printer in places subject to rapid changes in temperature and humidity. Also keep it away from direct sunlight, strong light, heat sources, or excessive moisture or dust.
- Avoid places subject to shocks and vibrations.
- Place the printer near a wall outlet where you can easily unplug the power cord.

Note for French-speaking users:

Placez l'imprimante près d'une prise de contact où la fiche peut être débranchée facilement.

- Avoid electrical outlets controlled by wall switches or automatic timers. An interruption in power can erase information in the memory of your printer or computer. Also avoid outlets on the same circuit as large motors or other appliances that can cause voltage fluctuations.
- Keep the entire computer system away from potential sources of electromagnetic interference, such as loudspeakers or the base units of cordless telephones.



1

- Use a grounded power outlet; do not use an adapter plug.
- Make sure the paper path is clear and unobstructed before you print on continuous paper. (See the next section.)

If you plan to use a printer stand, follow these guidelines:

- Use a stand that supports at least 26 kg (57.8 lb).
- Never use a stand that tilts the printer. The printer should always be kept level.
- Position your printer's power cord and interface cable so they do not interfere with paper feeding. If possible, secure the cables to a leg of the printer stand.

Positioning the continuous paper supply

Before using continuous paper, make sure you line up your paper supply with the tractor feeder so the paper feeds smoothly into the printer, as shown below.

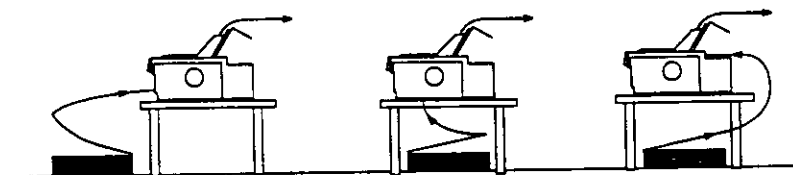

G2-8aaa.eps

Installing or Replacing the Ribbon Cartridge

This section describes how to install or replace the ribbon cartridge. The installation and replacement procedures are the same except that you need to remove the used ribbon cartridge before replacing it with a new one.

EPSON recommends using genuine EPSON ribbon cartridges (S015086). Products not manufactured by EPSON may cause damage to your printer not covered by EPSON's warranties.

**Warning:**

You will need to move the print head by hand to install or replace the ribbon cartridge. If you have just used the printer, the print head may be hot; let it cool for a few minutes before touching it.

1. Make sure the printer is turned off. The printer is off when the surface of the **Operate** button is even with the button protectors as shown.

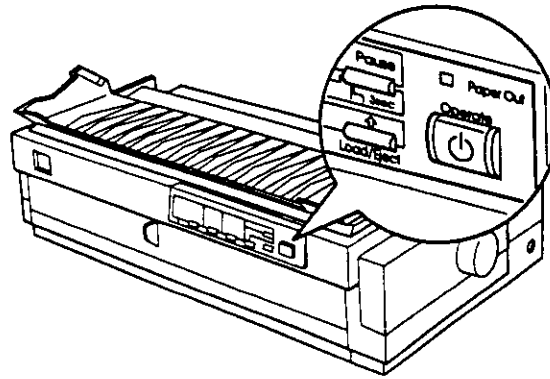
**Caution:**

Moving the print head while the printer is on may damage the printer.

2. If the printer is connected to an electrical outlet, unplug it from the outlet.

3. Lift the printer cover by its back edge and then pull it straight up and off.

1

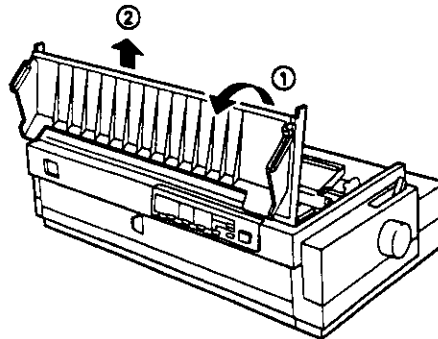

1-2.eps

4. Make sure that the print head is not hot; if it is, let it cool for a few minutes before touching it. Then slide the print head to the ribbon installation position (the indented portion of the paper tension unit) by hand.

Note:

When you use the pull tractor, you can replace the ribbon cartridge even though the print head is not positioned in the ribbon installation position.

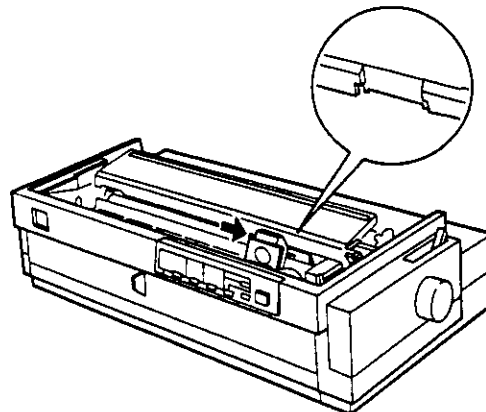

1-3-1.eps

5. If a used cartridge is installed, grasp the cartridge and pull it slightly forward and up; the ribbon guide snaps away from the metal pins behind the print head. Properly dispose of the used ribbon cartridge.

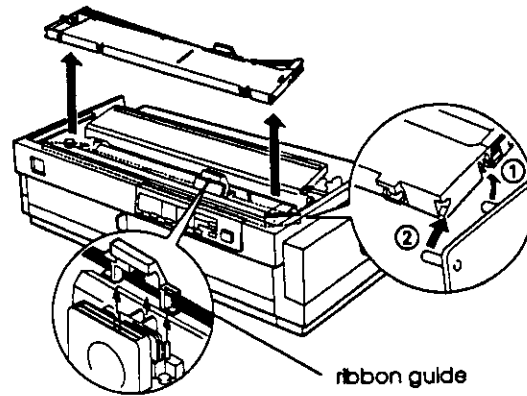

リスト
変更
(ヘッド部分)

New02.eps

6. Remove the new ribbon cartridge from the package. Remove the separator from the middle of the ribbon cartridge and discard the separator. Then turn the ribbon-tightening knob in the direction of the arrow to remove any slack in the ribbon.

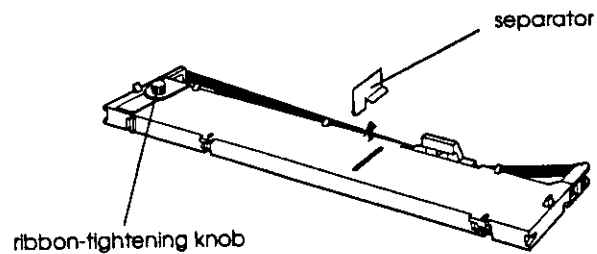

1-4.eps

7. Hold the cartridge with the ribbon-tightening knob up. Fit the two front notches of the ribbon cartridge over the small pegs on each side of the printer as shown below. Then lay the cartridge flat.

1

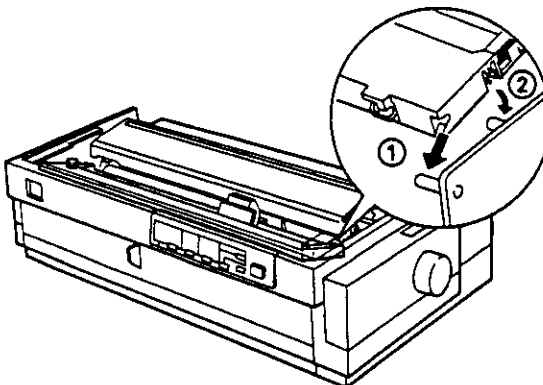

1-5a.eps

8. Make sure that the two rear notches of the cartridge fit over the small pegs on each side of the printer. Then gently press down the cartridge until both ends click into place.

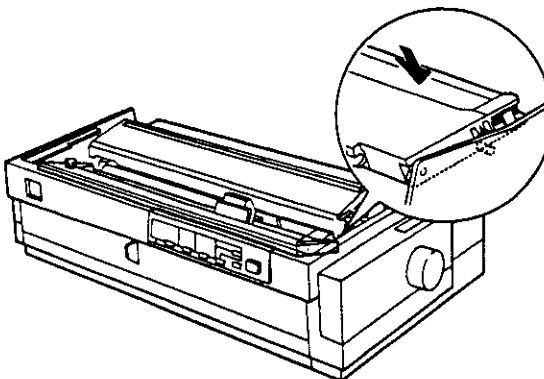

1-5b.eps

9. Lift the ribbon guide of the ribbon cartridge (①) and insert it firmly over the metal pins behind the print head (②). Make sure the ribbon is not twisted or creased and that it is in place behind the print head. Press down the guide until it clicks into place.

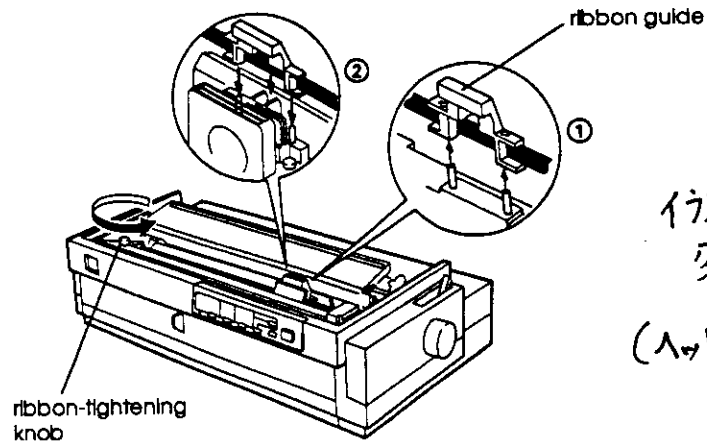

イースト
変更
(ヘッド部分)

1-6su.eps

10. Turn the ribbon-tightening knob in the direction of the arrow to remove any slack in the ribbon as shown above. Then slide the print head from side to side to make sure it moves smoothly.

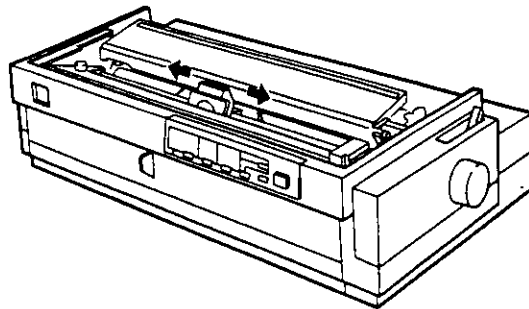

1-7.eps

11. Replace the printer cover by first inserting the front tabs into the slots on the printer and then lowering the cover until it clicks into place.

1

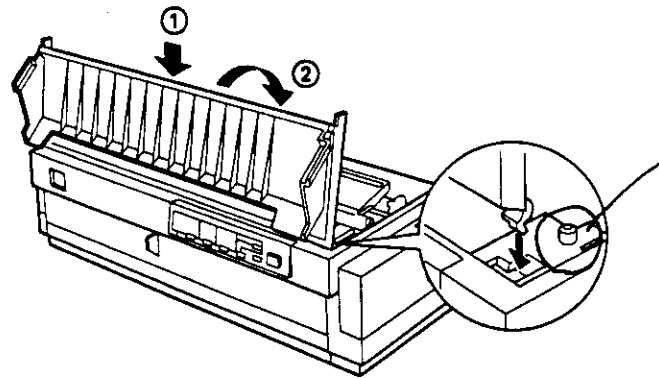

Attaching the Paper Guide and Paper Separator

To install the paper guide and paper separator, follow these steps:

1. Turn over the paper guide and insert the paper separator's tabs into the slots on the paper guide.

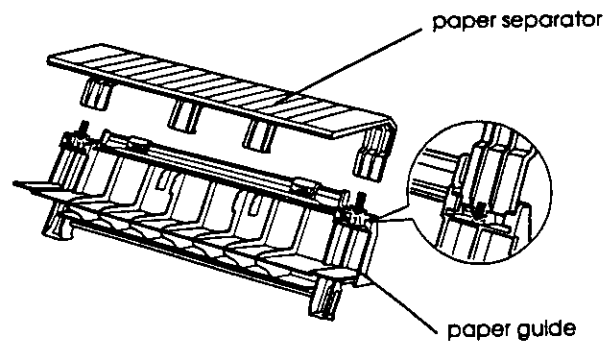

1-9n.eps

2. Make sure the paper guide cover is open as shown below. Attach the paper guide by sliding the slots on the bottom of the paper guide over the pegs behind the paper tension unit.

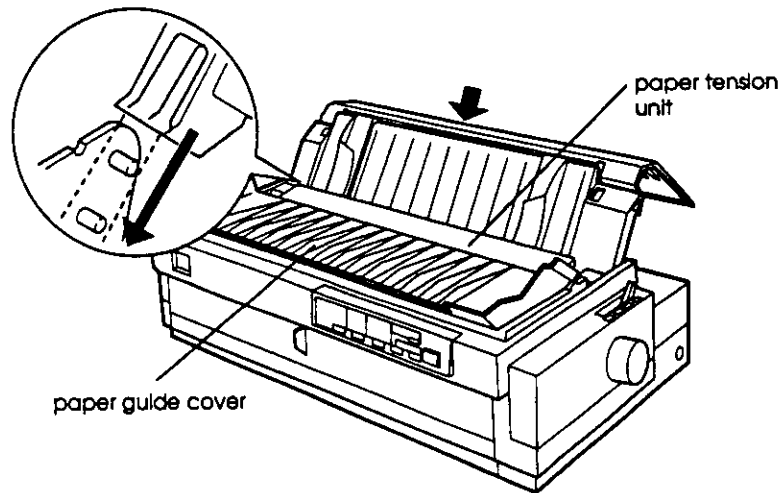

1-9.eps

3. Close the paper guide cover.

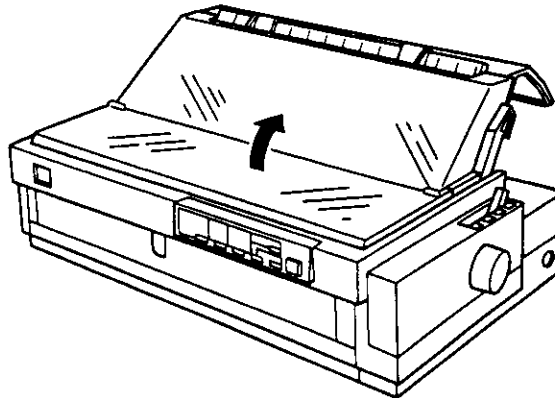

1-11.eps



Plugging In the Printer

1

1. Make sure the printer is turned off. The printer is off when the surface of the Operate button is even with the button protectors as shown below.

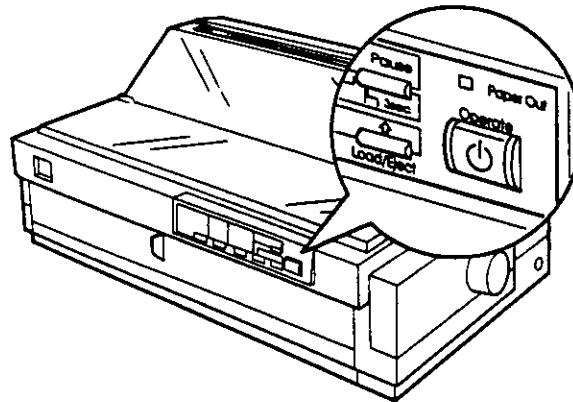

G1-10.eps

2. Check the label on the back of the printer to make sure its voltage matches that of your electrical outlet. Also make sure the plug on your printer's power cord matches your electrical outlet.



Caution:

It is not possible to change the printer's voltage. If the rated voltage and your outlet voltage do not match, contact your dealer for assistance. Do not plug in the power cord.

3. If the power cord is not attached to the printer, plug the appropriate end into the AC inlet on the back of the printer.
4. Plug the power cord into a properly grounded electrical outlet.

Connecting the Printer to Your Computer

To connect your computer to your printer's built-in parallel interface, you need a shielded, twisted-pair parallel cable with a D-SUB, 25-pin, male connector for your computer and a 36-pin Centronics® compatible connector for the printer.

If your computer requires a different type of printer interface, you should be able to use one of the optional interfaces described on page A-3.

Follow the steps below to connect the printer to your computer using the built-in parallel interface.

1. Make sure both the printer and computer are turned off. The printer is off when the surface of the Operate button is even with the button protectors.
2. Plug the cable connector securely into the printer's interface connector, and squeeze the wire clips together until they lock in place on both sides of the connector.

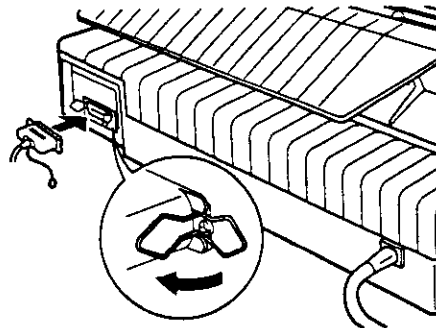

1-16.eps



3. If your cable has a ground wire, connect it to the printer's ground connector as shown below.

1

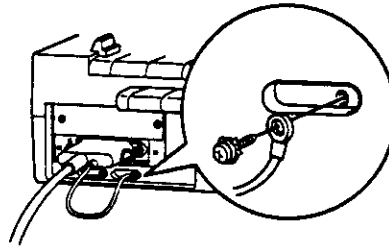

G1-12-2.eps

4. Plug the other end of the cable into the computer. (If the cable has a ground wire at the computer end, attach it to the ground connector at the back of the computer.)

After you connect the printer to your computer, install the printer software as described in the next section.

Installing the Printer Software

After connecting the printer to your computer, you need to install the software included on the EPSON printer software CD-ROM shipped with your printer.

Your printer software includes:

- Printer driver**
The printer driver is the software that runs, or "drives," your printer. With it, you can make settings such as print quality, resolution, and paper size.
- EPSON Status Monitor 2 (not for Windows 3.1 and NT 3.5x)**
The EPSON Status Monitor 2 notifies you of printer errors and displays printer status information.

If you are using DOS, see "For DOS programs" on page 1-18.

EPSON
Remote! ?
合子入マアか?
127-1000
は?
教習22<T3254
P4-24201-!

If you are using the floppy disk version of the software, make a backup copy of the EPSON printer software disk before you begin installation. If you wish to make a floppy disk version of the printer software on your CD-ROM, you can use the Driver disk creation utility included on the CD. See "Installing in Windows 95, 98, and NT4.0" or "Installing in Windows 3.1 and NT 3.5x" in this Chapter.

Installing in Windows 95, 98, and NT 4.0

Follows these steps below to install the printer software for Windows 95, 98, or Windows NT 4.0:

Note:

Installing the printer software for Window NT 4.0 may require network administration privileges. Ask your network administrator for more information.

1. Insert the printer software CD shipped with your printer in the CD-ROM drive. The Install dialog box appears. (For floppy disk users, insert disk in a disk drive, then double-click the FD drive icon and double-click the Setup.exe icon.)
2. Click Install to start the printer software installation.

Note:

- If the New Hardware Found screen or any other Wizard appears when you turn on your computer, click Cancel and follow the steps above.*
- Installation time varies depending on your computer.*
- If you wish to make a floppy disk version of the printer software included on your CD-ROM, run EPSETUP program. In the dialog box that appears, click the Driver disk creation utility button and follow the on-screen instruction.*

For information on opening and using the software, see "Using the Printer Software" in Chapter 4. See also "Using EPSON Status Monitor 2" in Chapter 6.

If you use your printer on a network with Windows 95, 98, or NT 4.0, see "Network Printing" in the online Reference Guide.

1

Installing in Windows 3.1 and NT 3.5x

Follows these steps below to install the printer software for Windows 3.1 or Windows NT 3.5x:

Note:

Installing the printer software for Window NT 3.5x may require network administration privileges. Ask your network administrator for more information.

1. Make sure Windows is running and the Program Manager window is open.
2. Insert the printer software CD shipped with your printer in the CD-ROM drive. (If you use the floppy disk version, insert it in a disk drive.)
3. Choose Run from the File menu. You see the Run dialog box. In the Command Line box, type D:SETUP and click OK. If the CD-ROM drive has a drive letter other than "D", or if you are using the floppy disk version, substitute the appropriate letter.

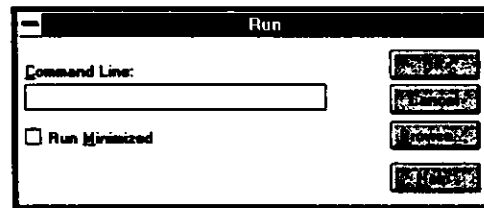

Note:

If you wish to make a floppy disk version of the printer software included on your CD-ROM, type EPSETUP instead of SETUP. In the dialog box that appears, click the Driver disk creation utility button and follow the on-screen instruction.

31run.tif

変

4. The installation program begins copying the printer software files.
5. When the installation is complete, click OK to exit the installation program.

The installation program automatically selects this printer as the default printer for Windows applications.

For information on opening and using the software, see "Using the Printer Software" in Chapter 4.

変更

For DOS programs

To control the printer from DOS application programs, you need to select the printer you are using or another available printer from the printer list of your application.

Choose the EPSON LQ-2180 printer at the appropriate step in the setup or installation procedure of your DOS application program. If the list in your application does not include the LQ-2180 printer, choose the first available printer from this list:

LQ-2170
LQ-1070/1070+
LQ-870/1170
LQ-850+/1050+
LQ-850/1050
LQ-510/550/1010
LQ-200
LQ-500
LQ-860+/1060+
LQ-2550
LQ-2500
LQ-800/1000
LQ-1500

Note:

If your application does not list a suitable alternative, contact the software manufacturer to see if an update is available.

Chapter 2

Printing on Continuous Paper



Setting the Paper Release Lever	2-2
Setting the Paper Thickness Lever	2-3
Loading Multi-Part Forms	2-5
Loading Continuous Paper With Labels	2-5
Removing continuous paper with labels	2-7
Using the Front Push Tractor	2-8
Installing the tractor in the front push position	2-8
Loading paper onto the front push tractor	2-9
Removing the printed document from the front push tractor	2-13
Removing the front push tractor	2-15
Using the Rear Push Tractor	2-16
Loading paper onto the rear push tractor	2-16
Removing the printed document from the rear push tractor	2-20
Using the Tractor in the Pull Position	2-21
Installing the tractor in the pull position	2-22
Loading paper onto the pull tractor	2-23
Removing paper from the pull tractor	2-29
Using two tractors in a push and pull combination	2-29
Removing the pull tractor	2-32
Switching Between Printing on Continuous Paper and Printing on Single Sheets	2-34
Switching to printing on single sheets	2-34
Switching to printing on continuous paper	2-35
Adjusting the Top-of-Form Position	2-36
Advancing the Paper to the Tear-Off Edge	2-39
Using the Tear Off/Bin button	2-39
Advancing paper to the tear-off position automatically ...	2-40
Adjusting the tear-off position	2-40

Setting the Paper Release Lever



You can load paper in the printer from various paper sources, such as the front push tractor or the paper guide. You set the paper release lever to indicate the paper source you want to use. The table below describes each paper release lever position.

Note:

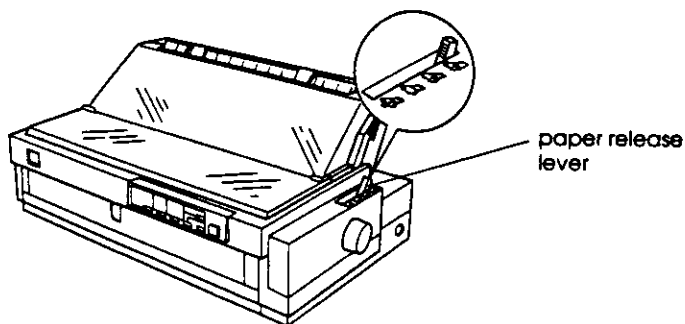
To decide which paper source and paper path best suits your printing needs, see "Available Paper Paths" on page 3.

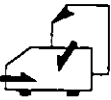

G2-8aaa.eps

Paper release lever position	Description
	Single-sheet position For loading single-sheet paper from the top or front slot. For information on loading single sheets, see Chapter 3.
	Rear push tractor position For loading continuous paper from the tractor installed in the rear push position. Also set the lever to this position when using the rear push and pull tractors in combination.
	Front push tractor position For loading continuous paper from the tractor installed in the front push position. Also set the lever to this position when using the front push and pull tractors in combination.

2-2g
2-4g
2-3g
2-5g



Paper release lever position	Description
	Pull tractor position For loading continuous paper from the tractor installed on top of the printer in the pull position. When the tractor is in the pull position, you can load paper in the front, rear, or bottom slot.



2-5g.eps

Note:

You can load two different types of continuous paper onto the front and rear push tractors, and easily switch between them using the paper release lever. Before moving the paper release lever, always press the Load/Eject button to feed the paper in the paper path backward to the standby position.

Setting the Paper Thickness Lever

Setting the paper thickness lever allows the printer to accommodate various thicknesses of paper. The paper thickness lever is located under the printer cover. You can select one of eight positions identified by the scale next to the lever.

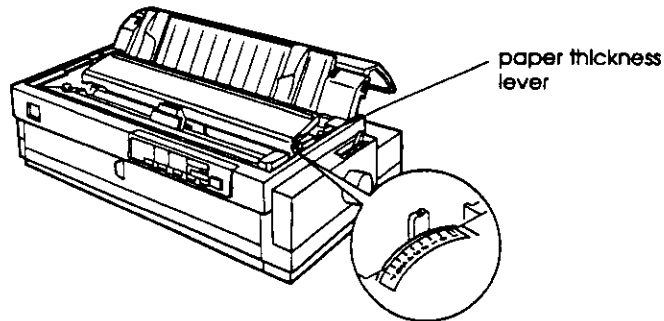

2-38n.eps

Use the following table to set the paper thickness lever to match the thickness of your paper.

Paper type*	Lever position
Ordinary (single sheets or continuous paper)	0
Thin paper	-1 or 0
Carbonless multi-part forms with: 2 parts (original + 1 copy) 3 parts (original + 2 copies) 4 parts (original + 3 copies) 5 parts (original + 4 copies) 6 parts (original + 5 copies)	1 2 3 5 7
Continuous paper with labels	2
Envelopes	2 or 6
Postcards	2

* See Appendix C for complete paper specifications.

Note:

- If the printed image is smeared, you may need to set the paper thickness lever one position higher to improve print quality.*
- If the printed image is faint or has many gaps, you may need to set the paper thickness lever one position lower to improve print quality.*

Loading Multi-Part Forms

You can use carbonless multi-part forms of up to six parts (five copies in addition to the original). Make sure you set the paper thickness lever to the proper position based on the number of layers in your form.

For best results with thick paper such as multi-part forms, select a straight or almost straight paper path. It is best to load multi-part forms using:

- the front slot and the front push tractor
- the front or bottom slot and the pull tractor

Except for setting the paper thickness lever, you load multi-part forms the same way you load ordinary continuous paper. For details, see the sections on loading continuous paper later in this chapter.

Note:

- Be sure your multi-part forms do not exceed 0.46 mm (0.018 inch) in thickness for the printable area and up to 0.9 mm (0.035 inch) for the perforated edges.*
- Do not load paper that is damaged, curled or wrinkled.*

Loading Continuous Paper With Labels

When printing on labels, use only the type of labels that are mounted on continuous backing sheets with sprocket holes for use with a tractor feeder. Do not try to print on single sheets with labels because the printer may not feed labels on a shiny backing sheet properly.

Thick paper, such as continuous paper with labels, requires a straight or almost straight paper path. You can load labels in the front (push tractor or pull tractor) or bottom (pull tractor) paper slot; however, for best results, use the tractor in the pull position and load paper in the front or bottom paper slot.

You load labels the same way you load ordinary continuous paper, except you must set the paper thickness lever to 2 before printing on labels. See "Loading paper onto the pull tractor" on page 2-23 for more information.

**Caution:**

- Do not load continuous paper with labels in the rear paper slot because the paper path from the rear slot is curved; labels may come off their backing sheet inside the printer and cause a paper jam.
- Never use the tear-off feature (by pressing the Tear Off/Bin button or turning on the auto tear-off mode as described in "About Your Printer's Default Settings" in Chapter 5) to feed continuous paper with labels backward; they may come off their backing sheet and jam the printer.
- Because labels are sensitive to temperature and humidity, use them only under normal operating conditions, as follows:

Temperature	15 to 25°C (59 to 77°F)
Humidity	30 to 60%RH
- Do not load continuous paper with labels that is damaged, curled or wrinkled.
- Do not leave labels loaded in the printer between jobs; they may curl around the platen and jam when you resume printing.

Removing continuous paper with labels

To avoid peeling labels off the backing sheet and jamming the printer, follow the steps below when you remove continuous paper with labels from the printer.

1. After you finish printing, tear off the fresh supply of continuous labels at the perforation nearest the paper entry slot.

2

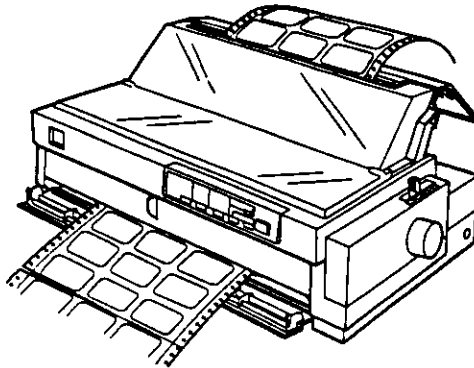

G3-19.eps

2. Hold down the LF/FF button to eject the remaining labels from the printer.



Caution:

Never press the Load/Eject or Tear Off/Bin button. When fed backward, labels can easily come off the backing sheet and cause a paper jam.

Using the Front Push Tractor

To use the front push tractor, load continuous paper in the front slot. For more information on when to use the front push tractor, see "Available Paper Paths" on page 3.

Note:

The tractors are installed in the front push and rear push positions when the printer is shipped. The rear push tractor cannot be removed.

Installing the tractor in the front push position

If a tractor is installed in the front push position, skip to "Loading paper onto the front push tractor" on the next page.

If a tractor is installed in the pull position, you need to remove it, and replace the paper tension unit as described on page 2-32 before using the front push tractor.

To install the tractor in the front push position, follow these steps:

1. Make sure the printer is turned off.
2. Open the front paper guide by pulling the tab at the center of the guide. Then remove the guide by grasping both sides and pulling it straight out of the printer.

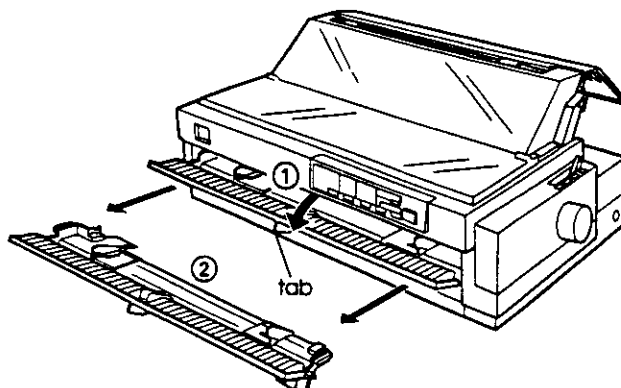

2-10.eps



3. Insert the tractor into the printer's mounting slots and press down both ends of the tractor to make sure that it is firmly seated.

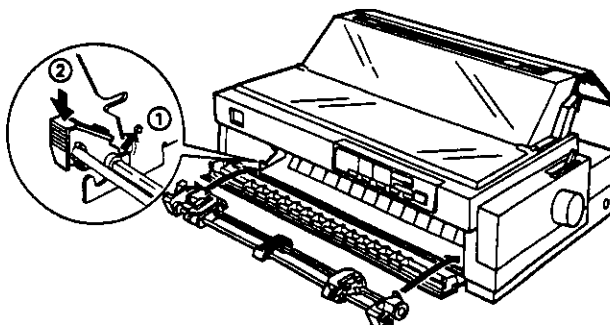

2

2-17.eps

You are now ready to load continuous paper onto the front push tractor as described in the next section. To remove the tractor, see page 2-15.

Loading paper onto the front push tractor

To load paper onto the front push tractor, follow these steps:

1. Open the front paper guide by pulling the tab at the center of the guide. Then remove the guide by grasping both sides and pulling it straight out of the printer. Check that the tractor is installed in the front push position.

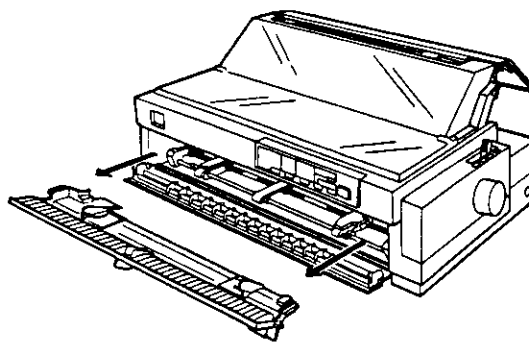

2-20.eps



2. Set the paper release lever to the front push tractor position. Also set the paper thickness lever (located under the printer cover) to the proper position for your paper's thickness.

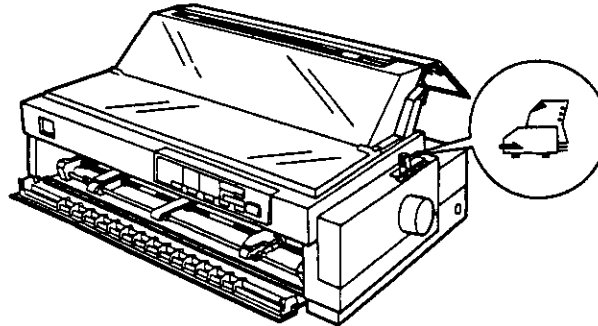

2-20a.eps

3. Release the left and right sprockets by pushing the sprocket lock levers backward.

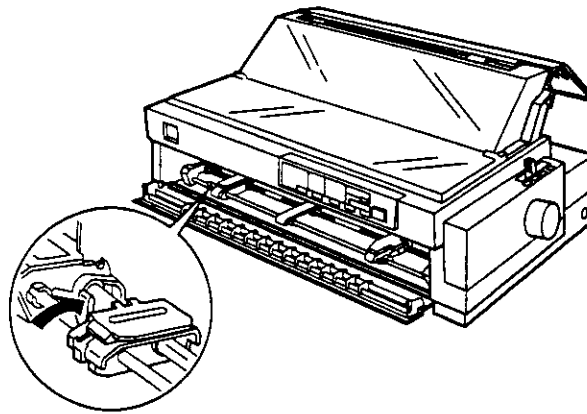

2-21.eps



- Slide the left sprocket to the left margin of your paper using the arrow mark inside the printer. (Printing starts at the arrow mark.) Then pull the lever forward to lock it in place.

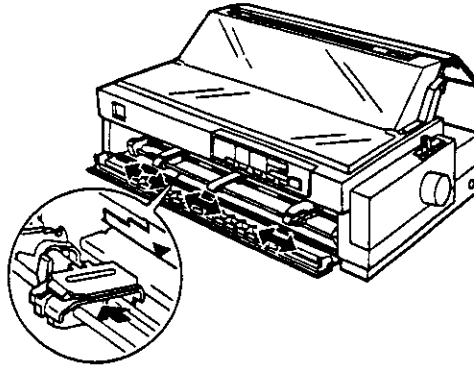

2

2-22.eps

Note:

See "Paper alignment" and "Printable area" in Appendix C for more information on the left margin position.

- Slide the right sprocket to match the width of your paper, but do not lock it. Move the paper support midway between the two sprockets as shown above.
- Open both sprocket covers. Make sure your paper has a clean, straight edge and fit the first four holes of the paper, printable side up, over the tractor pins. Then close the sprocket covers.

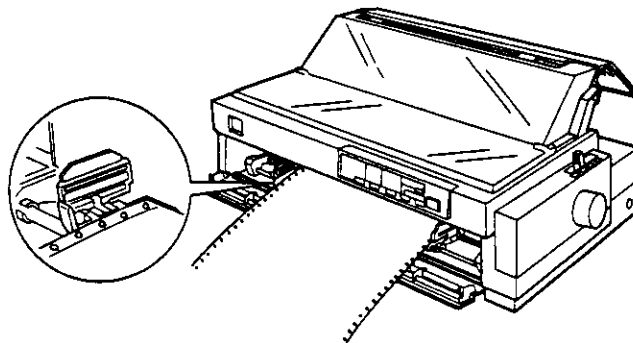

2-23.eps



7. Slide the right sprocket to remove any slack in the paper, then lock it in place by pushing the sprocket lock down.
8. Attach the front paper guide by sliding it along the printer's mounting slots as shown below. Then close the front paper guide.

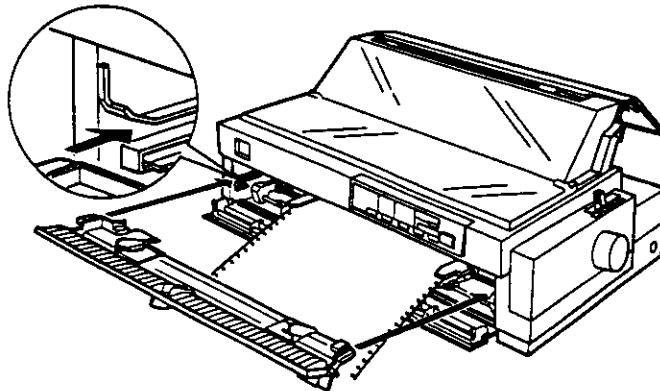

2-24.eps

9. Slide the edge guides to the middle of the top paper guide. Make sure that the printer cover and the paper guide cover are closed.

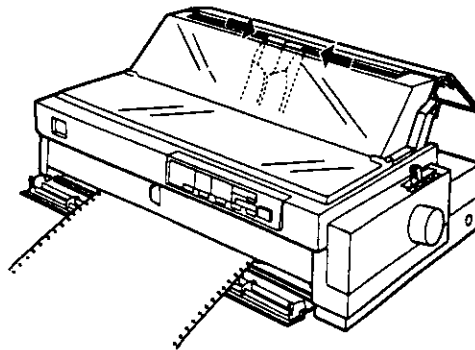

2-24a.eps

Note:

Always close the printer cover before printing. The printer does not print when the cover is open.



10. Make sure the printer is on. You may need to check and change the printer driver settings as described in Chapter 4. When the printer receives data, it automatically loads the paper and starts printing. The printed pages are fed over the paper guide toward the back of the printer.

2

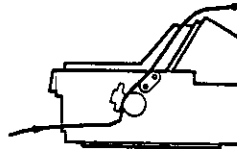

2-35a.eps

11. After you finish printing, follow the steps in the next section to tear off your printed document.

If the first printed line on your page appears too high or low, you can fix this using the micro adjust feature as described in "Adjusting the Top-of-Form Position" on page 2-36.



Caution:

Never use the knob to adjust the top-of-form position; this may damage the printer or cause it to lose the top-of-form position.

Removing the printed document from the front push tractor

To remove the printed document, follow these steps:

1. Make sure the Tear/Off Bin lights are flashing. (This indicates your paper is at the current tear-off position.) You may need to press the Tear Off/Bin button to advance the paper to the tear-off position.



2. Open the paper guide cover, and tear off the printed document using the tear-off edge of the printer.

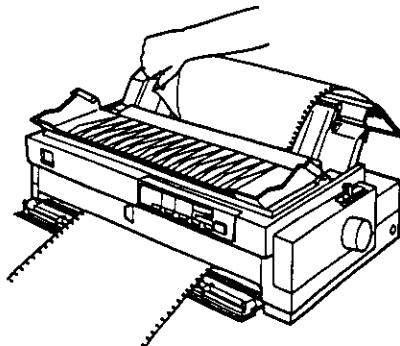

1-1.eps

Note:

If your paper's perforation is not properly aligned with the tear-off edge, you can adjust the tear-off position using the micro adjust feature. See "Adjusting the tear-off position" on page 2-40.

**Caution:**

Never use the knob to adjust the tear-off position; this may damage the printer or cause it to lose the tear-off position.

3. Close the paper guide cover.

When you resume printing, the printer automatically feeds the paper back to the top-of-form position and starts printing.

To remove the remaining paper from the printer, press the Load/Eject button to feed the paper backward to the standby position. (See the Glossary for an explanation of the standby position.) Then open the sprocket covers of the tractor and remove the paper.

**Caution:**

Always tear off your printed document before you press the Load/Eject button. Reverse feeding several pages at a time may cause a paper jam.

Removing the front push tractor

To remove the tractor from the front push position, follow these steps:

1. Remove any paper from the tractor as described in the previous section.
2. Turn off the printer.
3. Open the front paper guide by pulling the tab at the center of the guide. Then remove the guide by grasping both sides and pulling it straight out of the printer.
4. Press the tractor's lock tabs, tilt the tractor up, and lift it out of the printer.

2

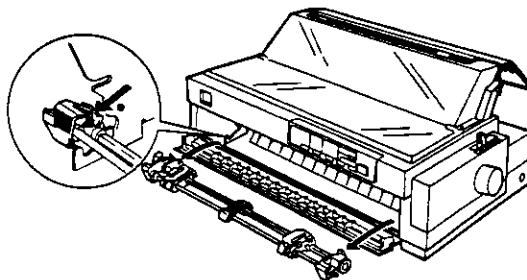

2-17nn.eps

5. Replace the front paper guide by sliding it along the printer's mounting slots until it locks in place. Then close the front paper guide.

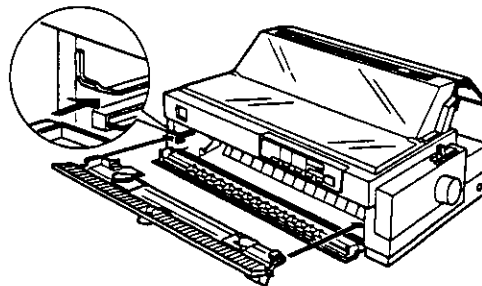

2-16b.eps

Using the Rear Push Tractor

To use the rear push tractor, load continuous paper in the rear slot. For information on when to use the rear push tractor, see "Available Paper Paths" on page 3.

Loading paper onto the rear push tractor

If a tractor is installed in the pull position, you need to remove it and replace the paper tension unit as described on page 2-32 before using the rear push tractor.

Note:

- To avoid paper jams, it is best to load thick multi-part forms using the front or bottom slot and pull or front push tractor.



Caution:

Do not load continuous paper with labels in the rear paper slot; the labels may come off their backing sheet inside the printer and cause a paper jam.

To load paper onto the rear push tractor, follow these steps:

1. Open the paper guide cover and remove the paper guide.

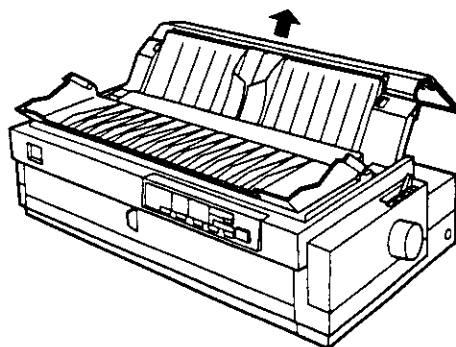

C.eps

Proof Sign-off:
<antname>
<leadname>
<editname>



Sun-E+
Pre Rev. C

A5 size
8/5/98

Chap2.fm
Pass 0

R

2. Set the paper release lever to the rear push tractor position. Also set the paper thickness lever (located under the printer cover) to the proper position for your paper's thickness.

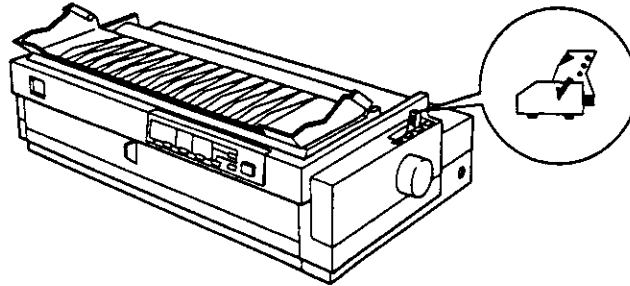

2

2-26.eps

3. Release the left and right sprockets by pulling the sprocket lock levers forward.

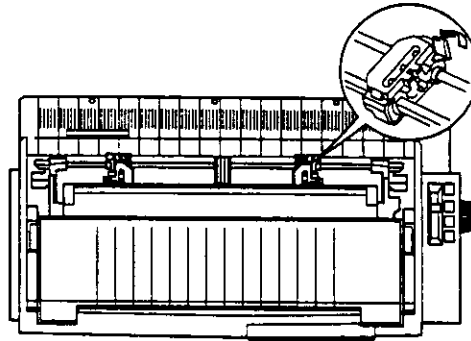

front of the printer

2-27.eps

4. Slide the left sprocket to the left margin of the paper using the scale on the printer. (Printing starts at the "0" mark.) Then push the lever back to lock it in place.

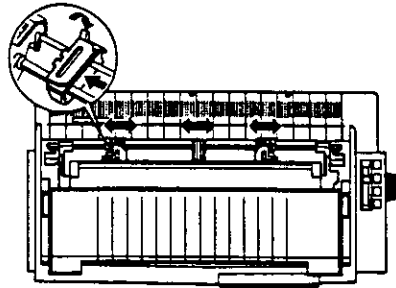

front of the printer

2-28.eps

Note:

See "Paper alignment" and "Printable area" in Appendix C for more information on the left margin position.

5. Slide the right sprocket to match the width of your paper, but do not lock it. Move the paper support midway between the two sprockets as shown above.
6. Open both sprocket covers. Make sure your paper has a clean, straight edge and fit the first four holes of the paper, printable side down, over the tractor pins. Then close the sprocket covers.

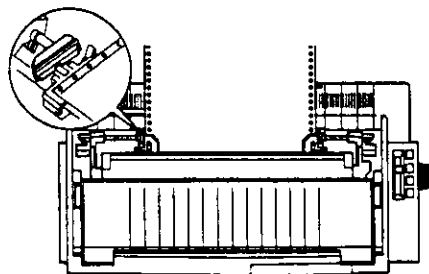

front of the printer

2-29.eps

7. Slide the right sprocket to remove any slack in the paper; then lock it in place by pushing the sprocket lock down.

8. Attach the paper guide as described on page 1-11.
9. Slide the edge guides to the middle of the paper guide. Then close the paper guide cover.

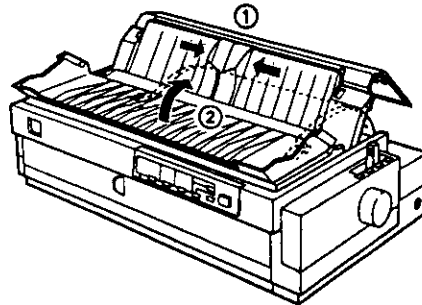

2-29a.eps

Note:

Always close the printer cover before printing. The printer does not print when the cover is open.

10. Make sure the printer is on. You may need to check and change the printer driver settings as described in Chapter 4. When the printer receives data, it automatically loads the paper and starts printing. The printed pages are fed over the paper guide toward the back of the printer.

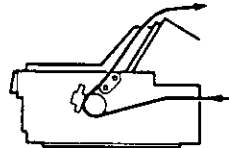

2-35c.eps

11. After you finish printing, follow the steps in the next section to tear off your printed document. If the first printed line on your page appears too high or low, you can fix this by using the micro adjust feature as described in "Adjusting the Top-of-Form Position" on page 2-36.



Caution:

Never use the knob to adjust the top-of-form position; this may damage the printer or cause it to lose the top-of-form position.

Removing the printed document from the rear push tractor

To remove the printed document, follow these steps:

1. Make sure the Tear Off/Bin lights are flashing. (This indicates your paper is at the current tear-off position). You may need to press the Tear Off/Bin button to advance the paper to the tear-off position.
2. Open the paper guide cover, and tear off the printed document using the tear-off edge of the printer.

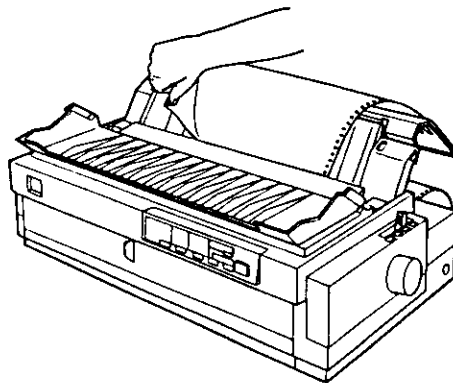

P3-9.eps

Note:

If your paper's perforation is not properly aligned with the tear-off edge, you can adjust the tear-off position using the micro adjust feature. See "Adjusting the tear-off position" on page 2-40.



Caution:

Never use the knob to adjust the tear off position; this may damage the printer or cause it to lose the tear-off position.

3. Close the paper guide cover.

When you resume printing, the printer automatically feeds the paper back to the top-of-form position and starts printing.

To remove the remaining paper from the printer, press the Load/Eject button to feed the paper backward to the standby position. (See the Glossary for an explanation of the standby position.) Then open the sprocket covers of the tractor and remove paper.



Caution:

Always tear off your printed document before you press the Load/Eject button. Reverse feeding several pages at a time may cause a paper jam.

2

Using the Tractor in the Pull Position

Using the tractor in the pull position is ideal for printing on thick and heavy continuous paper, such as multi-part forms or continuous paper with labels. However, you cannot use the tear-off feature with the pull tractor.

You can also load paper onto the pull tractor from the rear slot. However, doing so is not recommended because the paper path from the rear slot is curved. Because thick paper requires a straight paper path to avoid paper jams, it is best to load paper in the front or bottom slot when using the pull tractor.



Caution:

Do not load continuous paper with labels in the rear paper slot; the labels may come off their backing sheet inside the printer and cause a paper jam.

To further reduce the chance of paper jams and improve the performance of continuous paper, you can use two tractors in combination. When using this printing method, you load your paper onto both the front push tractor and the pull tractor, or both the rear push tractor and the pull tractor. See "Using two tractors in a push and pull combination" on page 2-29.

Installing the tractor in the pull position

To install a tractor in the pull position you must either remove the front push tractor or install the optional pull tractor (C80032*). To remove the front push tractor, see "Removing the front push tractor" on page 2-15.

Note:

The tractor in the rear push position cannot be removed.

To install a tractor in the pull position, follow these steps:

1. Make sure the printer is turned off. Lift the printer cover up and off the printer.
2. Push up the tabs on each side of the paper tension unit and lift the unit up and off the printer. Store the paper tension unit in a safe place.

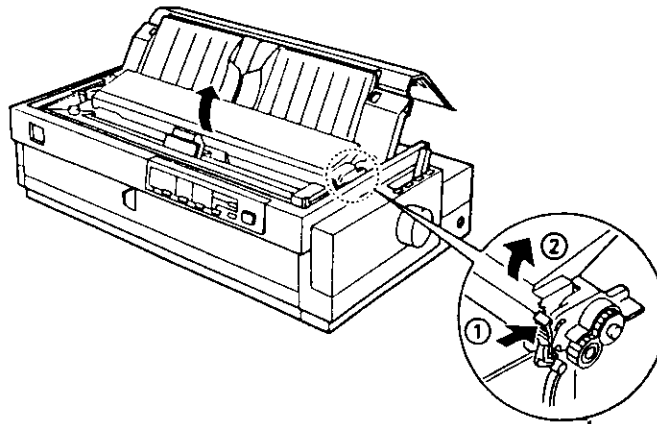

2-18nn.eps

Proof Sign-off:
<antoname> _____
<leadename> _____
<editorname> _____

Sun-E+ Pre Rev. C

A5 size
8/5/98

Chap2.fm
Pass 0

R

3. Lower the tractor into the printer's mounting slots and press down both ends of the tractor to make sure that it is firmly seated.

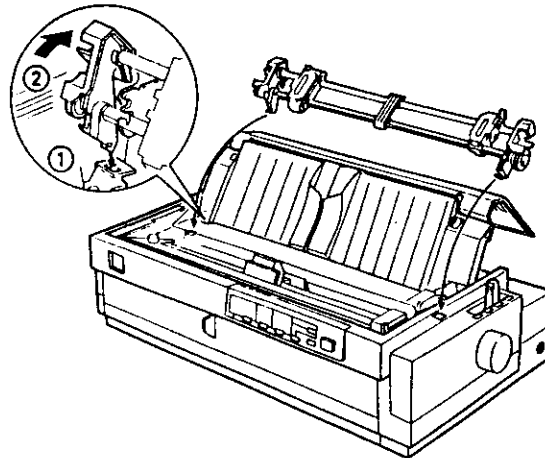

2

2-19nn.eps

You are now ready to load continuous paper onto the pull tractor as described in the next section. To remove the pull tractor, see page 2-32.

Loading paper onto the pull tractor

When using the pull tractor, load continuous paper in the front or bottom slot, if possible; loading paper in the rear slot may increase the chance of a paper jam.



Caution:

- Do not load continuous paper with labels in the rear paper slot; the labels may come off their backing sheet inside the printer and cause a paper jam.

To load paper onto the pull tractor, follow these steps:

1. Make sure the printer is turned off, and the printer cover is removed. Also check that a tractor is installed in the pull position.
2. Slide the edge guides to the middle of the paper guide.
3. Set the paper release lever to the pull tractor position. Also set the paper thickness lever to the proper position for your paper's thickness.

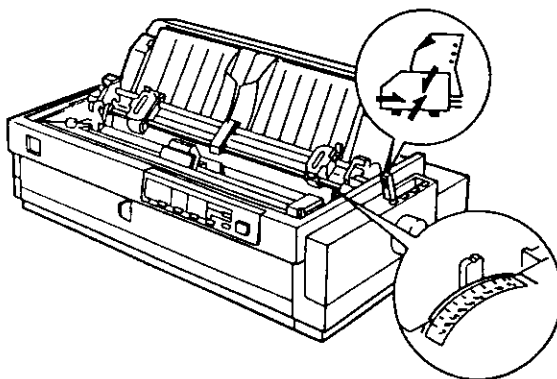

2-31.eps

4. Release the left and right sprockets by pulling the sprocket lock levers forward.

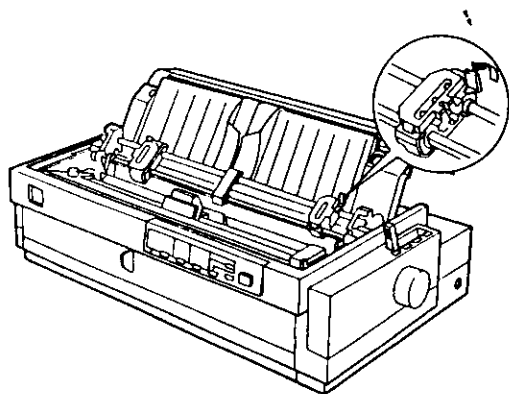

2-32a.eps

Proof Sign-off:
<tantoname>
<leadername>
<editorname>

Sun-E+
Pre Rev. C

A5 size
8/5/98

Chap2.fm
Pass 0

R

5. Slide the left sprocket to the left margin of the paper using the scale on the paper guide as a guide. (Printing starts at the arrow mark.) Then push the lever back to lock it in place.

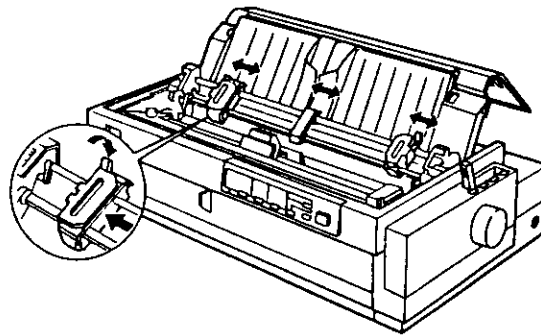

2

2-33a.eps

Note:

See "Paper alignment" and "Printable area" in Appendix C for more information on the left margin position.

6. Push back the left sprocket lever to lock it in place.
7. Slide the right sprocket to match the width of your paper, but do not lock it. Move the paper support midway between the two sprockets as shown above. Then open both sprocket covers.
8. Make sure your paper has a clean, straight edge.



9. Insert the paper into the front, bottom, or rear paper slot as described below until it emerges between the platen and the ribbon guide. Then pull up the paper until the perforation between the first and second pages is even with the top of the printer's ribbon.

Before you load paper in the front slot, remove the front paper guide. Then load paper printable side up.

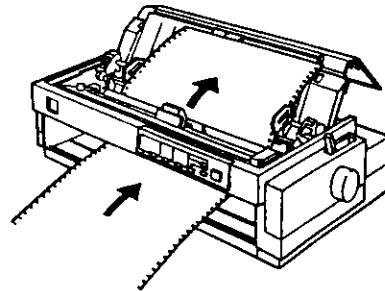

2-34a.eps

Load paper in the bottom slot printable side up (forward).

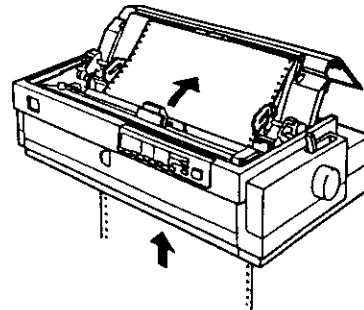

2-34b.eps

Before you load paper in the rear slot, remove the paper guide. Then load paper in the rear slot printable side down.

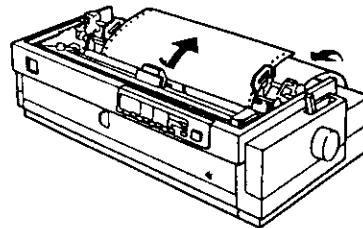

2-34c.eps

10. Fit four holes of the paper over the tractor pins on both sprockets. Then close the sprocket covers.
11. Slide the right sprocket to remove any slack in the paper; then lock it in place by pushing the sprocket lock down.

12. If you use the front slot, attach the front paper guide with the continuous paper positioned as shown below. Then close it.

If you use the rear slot, replace the paper guide and make sure the edge guides are together in the middle of the paper guide.

2

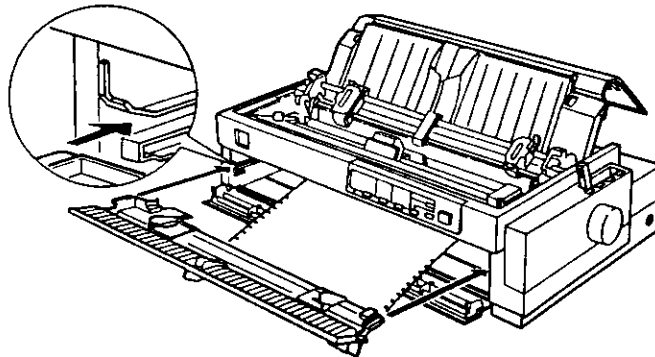

G3-19-aa.eps

13. Turn on the printer.
14. Remove any slack in the paper and adjust the top-of-form position (the position where the printer will start printing) by pressing the LF/FF button or using the micro adjust feature. (To use the micro adjust feature, see "Adjusting the Top-of-Form Position" on page 2-36.) The printer will start printing at the current position without advancing the paper.



Caution:

- Never use the knob to remove slack in the paper or to adjust the top-of-form position; this may damage the printer or cause it to lose the top-of-form position.
- Always remove any slack from the paper; otherwise print quality may be reduced.

15. Attach the printer cover and close the paper guide cover.

Note:

Always close the printer cover before printing. The printer does not print when the cover is open.



16. You may need to check and change the printer driver settings as described in Chapter 4. Send a print job to the printer. The printer starts printing from the current position without advancing the paper. The printed pages are fed over the paper guide toward the back of the printer.

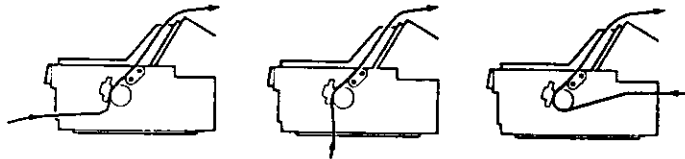

2-35.eps

17. After you finish printing, open the paper guide cover; then tear off the printed document at the perforation nearest the paper exit slot.

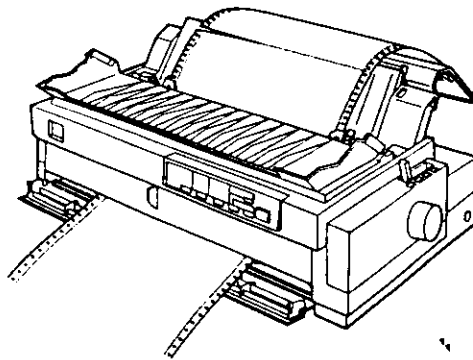

New10.eps

Removing paper from the pull tractor

1. After you finish printing, tear off the fresh supply of paper at the perforation nearest the paper entry slot.

2

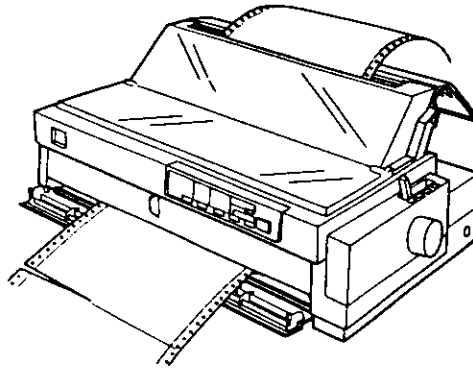

G05-1.eps

2. Hold down the LF/FF button to eject the paper from the printer.



Caution:

Never press the Load/Eject button when using the pull tractor; feeding the paper backward may cause it to come off the pull tractor and jam the printer.

Using two tractors in a push and pull combination

To improve continuous paper feeding and reduce paper jams, you can use two tractors at the same time. When using two tractors in combination, you can load paper in the front paper slot onto both the front push tractor and the pull tractor, or in the rear paper slot onto both the rear push tractor and the pull tractor.

To use the front push tractor with the pull tractor, you need to purchase the optional pull tractor (C80032*). The tractor in the rear push position cannot be removed. Install the optional pull tractor as described in "Installing the tractor in the pull position" on page 2-22.

To use the rear push tractor with the pull tractor, you can remove the tractor from the front push position as described on page 2-15, and install it in the pull position as described on page 2-22.

Note:

The tractor in the rear push position cannot be removed.

To load paper onto two tractors, follow these steps:

1. Remove the printer cover and paper guide.
2. Make sure one tractor is in the front or rear push position and one tractor is in the pull position. Set the paper release lever to either the front push or rear push tractor position, depending on which push tractor you are using. Also, set the paper thickness lever to the proper position for your paper's thickness.
3. Load paper onto the front or rear push tractor as described earlier in this chapter.
4. Turn on the printer. Press the Load/Eject button to advance the paper to the top-of-form position. Then press the LF/FF button until the perforation between the first and second pages is even with the top of the printer's ribbon.

**Caution:**

Never use the knob to move the paper; this may damage the printer or cause it to lose the top-of-form position.

5. Attach the paper to the pull tractor's sprockets as described in "Loading paper onto the pull tractor" on page 2-23.
6. Set the paper release lever to the pull tractor position. Then remove any slack in the paper between the push and pull tractors using the micro adjust feature (described on page 2-36) if necessary.
7. Move the paper release lever back to the push tractor position you set in step 2.
8. Adjust the top-of-form position (the position where the printer will start printing) using the micro adjust feature as described in "Adjusting the Top-of-Form Position" on page 2-36. The printer will start printing at the current position without advancing the paper.

2



Caution

- Never use the knob to remove slack in the paper or to adjust the top-of-form position; this may damage the printer or cause it to lose the top-of-form position.
 - Always remove any slack from the paper; otherwise print quality may be reduced.
9. Attach the paper guide. Then slide the edge guides to the middle of the paper guide.
 10. Attach the printer cover and close the paper guide cover.

Note:

Always close the printer cover before printing. The printer does not print when the cover is open.

11. You may need to check and change the printer driver settings as described in Chapter 4. Send a print job to the printer. The printer starts printing from the current position without advancing the paper. The printed pages are fed over the paper guide toward the back of the printer.

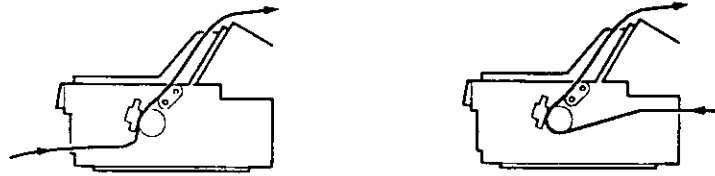

2-35ac.eps

12. After you finish printing, open the paper guide cover; then tear off the printed document at the perforation nearest the paper exit slot.

To remove the paper from the tractors, follow the steps under "Removing paper from the pull tractor" on page 2-29.

Removing the pull tractor

To remove the tractor from the pull position, follow these steps:

1. Remove any paper loaded on the pull tractor as described on page 2-30.
2. Turn off the printer. Then remove the printer cover and lift the paper guide up and off the printer.

3. Press the tractor's lock tabs, tilt the tractor toward you, and lift it off the printer.

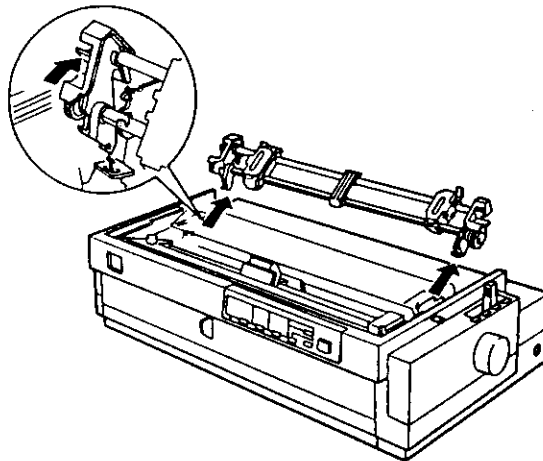

2

G3-17-3.eps

4. Store the tractor in a safe place, or install it in the front push position as described on page 2-8.
5. To replace the paper tension unit, lower it onto the printer's mounting pegs. Then press down both ends of the unit until it clicks into place.

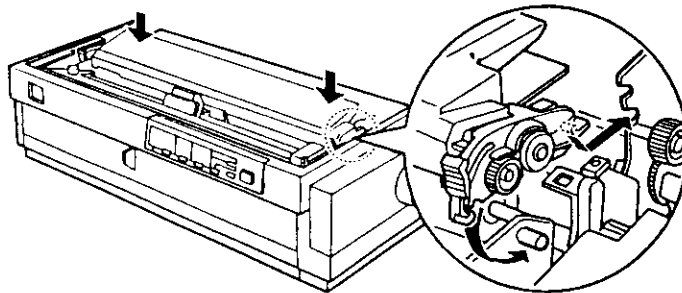

G1-9-1.eps

6. Replace the paper guide and printer cover. Then close the paper guide cover.

Switching Between Printing on Continuous Paper and Printing on Single Sheets

You can easily switch back and forth between printing on continuous paper with a push tractor and printing on single sheets without having to remove or reload paper.

Switching to printing on single sheets

To switch from printing on continuous paper with the front or rear push tractor to printing on single sheets, follow the steps below.

Note:

- If continuous paper with labels is loaded in the printer, remove it before switching to single-sheet printing. See "Removing continuous paper with labels" on page 2-8.
 - If a tractor is in the pull position, remove any continuous paper from it before switching to single-sheet printing. See "Removing paper from the pull tractor" on page 2-29.
1. If any printed pages of continuous paper remain in the printer, press the Tear Off/Bin button to advance printed pages to the tear-off position, and then tear them off.



Caution:

- Tear off your printed document before you press the Load/Eject button in the next step. Reverse feeding several pages at a time may cause a paper jam.
- Never use the knob to eject paper while the printer is on; this may damage the printer or cause it to lose the tear-off position.

2. Press the Load/Eject button to feed the continuous paper backward to the standby position. The paper is still attached to the push tractor but is no longer in the paper path.
3. Load single sheets in the top or front paper guide as described in Chapter 3.

2

Switching to printing on continuous paper

To switch from printing on single sheets to printing on continuous paper with the front or rear push tractor, follow these steps:

1. If a single sheet remains in the printer, press the Load/Eject button to eject it.



Caution:

Never use the knob to eject paper while the printer is on; this may damage the printer or cause it to lose the top-of-form position.

2. Make sure that the tractor is installed in the front or rear push position which you plan to use. To install the tractor in the front position, see page 2-8.
3. Load continuous paper onto the front or rear push tractor as described earlier in this chapter.

The printer loads your continuous paper automatically when you begin printing.

Adjusting the Top-of-Form Position



The top-of-form position is the position on the page where the printer will start printing. If your printing appears too high or low on the page, you can use the micro adjust feature to adjust the top-of-form position as described below.

**Caution:**

Never use the knob to adjust the top-of-form position; this may damage the printer or cause it to lose the top-of-form position.

Note:

- Your top-of-form position setting remains in effect until you change it, even if you turn off the printer.*
 - The top margin setting made in some application software overrides the top-of-form position setting you make with the micro adjust feature. If necessary, adjust the top-of-form position using your software.*
1. Make sure the printer is turned on.
 2. If necessary, load paper as described earlier in this chapter. If you load paper onto a push tractor, press the Load/Eject button to advance the paper to the current top-of-form position.
 3. Lift the printer cover up and off the printer.
 4. Hold down the Pause button for about three seconds. The Pause light starts flashing and the printer enters the micro adjust mode.

5. Press the LF/FF  button to move the top-of-form position up on the page, or press the Load/Eject  button to move the top-of-form position down on the page.



Caution:

Never use the knob to adjust the top-of-form position; this may damage the printer or cause it to lose the top-of-form position.

2

plastic ribbon cover

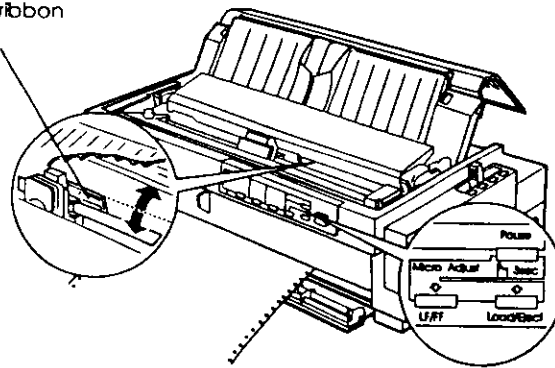

3-6anew.eps

Note:

- The printer has a minimum and a maximum top-of-form position. If you try to adjust it beyond these limits, the printer beeps and stops moving the paper.
- When the paper reaches the default top-of-form position, the printer also beeps and stops moving the paper briefly. You can use the default setting as a reference point when adjusting the top-of-form position.

L

Sun-E+
Pre Rev. C

A5 size
8/5/98

Chap2.fm
Pass 0

Proof Sign-off:

<tantoname>

<leadername>

<editorname>

To adjust the top-of-form position for continuous paper loaded on the pull tractor, see the following example:

First mark a point 6.5 mm (0.26 inch) above the paper's perforation; then position the paper so that the mark is even with the top edge of the plastic ribbon cover. This gives you an 8.5 mm (0.33 inch) margin on the next page, meaning the printer starts printing 8.5 mm below the perforation. If you mark a point 5.5 mm (0.22 inch) above the perforation, you get a 9.5 mm (0.37 inch) margin on the next page.

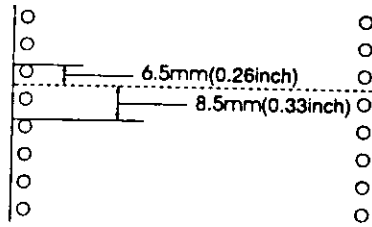

New14.eps

6. After you set the top-of-form position, press the Pause button to exit micro adjust mode.

Advancing the Paper to the Tear-Off Edge

If you use the front or rear push tractor, you can use the tear-off feature to advance your continuous paper to the printer's tear-off edge when you finish printing. You can then easily tear off the printed document. When you resume printing, the printer automatically feeds the paper back to the top-of-form position so that you can save the paper normally lost between documents.

As described below, you can use the tear-off feature in two ways: manually by pressing the printer's Tear Off/Bin button, or automatically by turning on the auto tear-off mode.

If the perforation between pages is not aligned with the tear-off edge, you can adjust the position of the perforation using the micro adjust feature. See "Adjusting the tear-off position" on page 2-40 for instructions.



Caution:

Never use the tear-off feature (by pressing the Tear Off/Bin button or turning on the auto tear-off mode as described below) to feed continuous paper with labels backward; they may come off their backing sheet and jam the printer.

Using the Tear Off/Bin button

After the printer finishes printing your document, check that the Tear Off/Bin lights are not flashing. Then press the Tear Off/Bin button. The printer advances the paper to the tear-off edge.

Note:

If the Tear Off/Bin lights are flashing, the paper is in the tear-off position. If you press the Tear Off/Bin button, the printer feeds your paper to the next top-of-form position.

Advancing paper to the tear-off position automatically

To automatically advance your printed documents to the tear-off position, you need to turn on the auto tear-off mode and select the appropriate page length for continuous paper in the default-setting mode. For instructions, see "About Your Printer's Default Settings" on page 5-4.

When auto tear-off is on, the printer automatically advances the paper to the tear-off position whenever it receives a full page of data or a form feed command followed by no more data.

Adjusting the tear-off position

If your paper's perforation is not aligned with the tear-off edge, you can use the micro adjust feature to move the perforation to the tear-off position. Follow the steps below.

**Caution:**

Never use the knob to adjust the tear-off position; this may damage the printer or cause it to lose the tear-off position.

Note:

Your tear-off position setting remains in effect until you change it, even if you turn off the printer.

1. Make sure the Tear Off/Bin lights are flashing (the paper is at the current tear-off position). You may need to press the Tear Off/Bin button to advance the paper to the tear-off position.
2. Open the paper guide cover.
3. Hold down the Pause button for about three seconds. The Pause light begins flashing and the printer enters the micro adjust mode.

Proof Sign-off:
<antoname> _____
<leadname> _____
<editname> _____

Sun-E+ Pre Rev. C

A5 size
8/5/98

Chap2.fm
Pass 0

R

4. Press the LF/FF \blacktriangledown button to feed the paper backward, or press the Load/Eject \blacktriangle button to feed the paper forward, until the paper perforation is aligned with the tear-off edge.

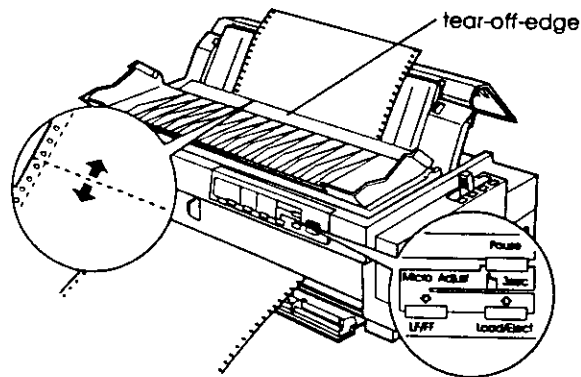

2

3-6bnew.eps

Note:

The printer has a minimum and a maximum tear-off position. If you try to adjust the tear-off position beyond these limits, the printer beeps and stops moving the paper.

5. After you set the tear-off position, press the Pause button to turn off micro adjust mode.
6. Tear off the printed pages.

When you resume printing, the printer automatically feeds the paper back to the top-of-form position and begins printing.

L

Sun-E+
Pre Rev. C

A5 size
6/5/98

Chap2.fm
Pass 0

Proof Sign-off:
<antoname>
<leadname>
<editname>

Proof Sign-off:
<tanfoname> _____
<leadename> _____
<editorname> _____

Sun-E+
Pre Rev. C

A5 size
8/5/98

Chap3.fm
Pass 0

R

Chapter 3

Printing on Single Sheets

Using Single Sheets	3-2
Available paper types and paper slots	3-2
Loading single-sheet multi-part forms	3-4
Loading envelopes	3-6
Loading postcards	3-7
Loading Single Sheets in the Top Paper Slot	3-8
Loading Single Sheets in the Front Paper Slot	3-10



Using Single Sheets

Available paper types and paper slots

As shown below, you can load single-sheet paper one sheet at a time using the paper guide on top of the printer or the front paper guide. You can print on ordinary single sheets, single-sheet multi-part forms, postcards, and envelopes. Your single-sheet paper may be from 101 to 420 mm (4.0 to 16.5 inches) wide.

Note:

- To load a stack of single-sheet paper, use the optional cut-sheet feeder. See Appendix A, "Enhancing Your Printer With Options."
- For detailed specifications on the types of single-sheet paper you can use, see Appendix C.

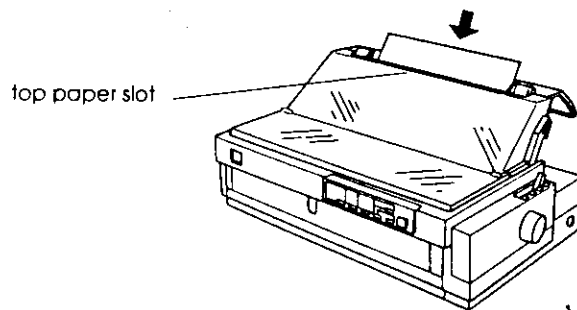

2-9n.eps

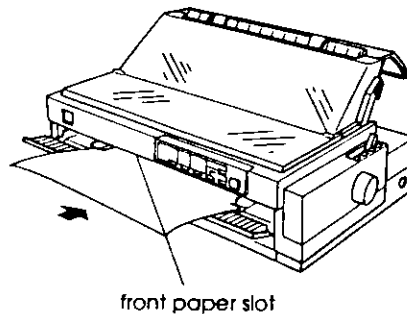

2-12.eps

Proof Sign-off:
 <antoname> _____
 <leadername> _____
 <editorname> _____

Sun-E+
Pre Rev. C

A5 size
 8/5/98

Chap3.fm
 Pass 0

R

The table below shows the types of paper you can load in the top and front paper slots and the paper thickness lever settings for each paper type. For more information on the paper thickness lever, see page 2-3.

Paper type	Available paper slots	Paper thickness lever position
Ordinary single-sheet paper	Top and front	-1 or 0
Multi-part forms (carbonless) 2 parts (original + 1 copy) 3 parts (original + 2 copies) 4 parts (original + 3 copies) 5 parts (original + 4 copies) 6 parts (original + 5 copies)	Top and front	1 2 3 5 7
Postcards	Top and front	2
Envelopes	Top	2 to 6

3

Note:

- If the printed image is smeared, you may need to set the paper thickness lever one position higher to improve print quality.
- If the printed image is faint or has many gaps, you may need to set the paper thickness lever one position lower to improve print quality.
- Do not load paper that is damaged, curled or has been folded.

Loading single-sheet multi-part forms

You can load single-sheet multi-part forms one at a time in the top or front paper slot as described in "Loading Single Sheets in the Top Paper Slot" or "Loading Single Sheets in the Front Paper Slot," later in this chapter. Also, follow these guidelines:

- Use only carbonless multi-part forms bound as shown below.

bound only at the top
by line glueing

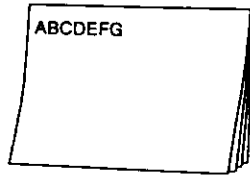

bound only at the side
by line glueing

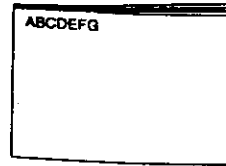

New04.eps

New06.eps

- You can use the top or front paper slot to load single-sheet multi-part forms that are bound at the top.

Insert this type of form in the top slot with the bound edge first and the printable side down, as shown below.

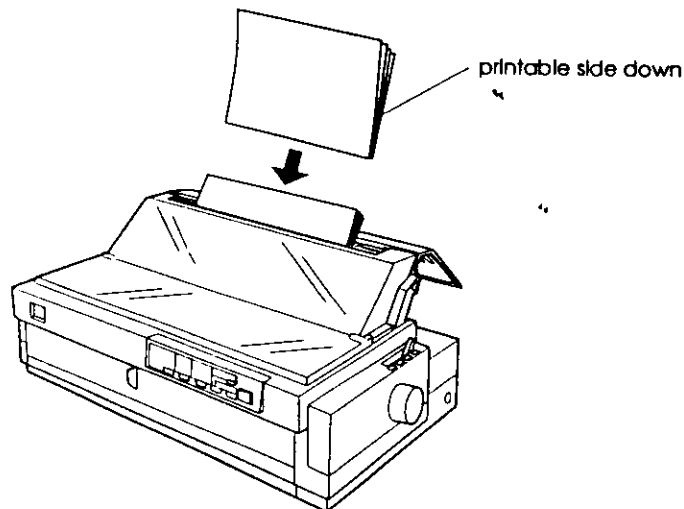

New03.eps

Proof Sign-off:
<fontname>
<leadname>
<editname>



Sun-E+ Pre Rev. C

A5 size
8/5/98

Chap3.fm
Pass 0

R

Insert this type of form in the front slot with the bound edge first and the printable side up, as shown below.

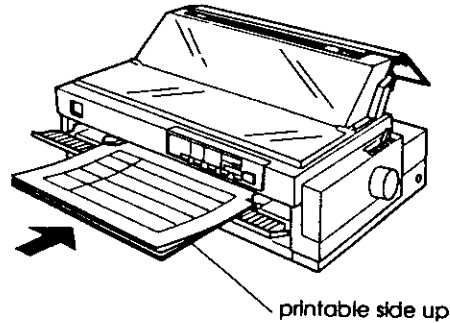

3

New05.eps

- You can load multi-part forms bound at the side only in the front slot. Insert this type of form in the front slot with the top edge first and the printable side up, as shown below.

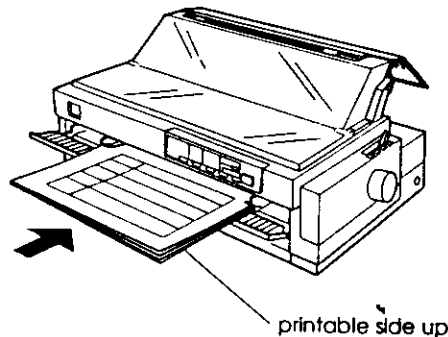

New07.eps

- Before printing, set the paper thickness lever (located under the printer cover) to the proper position for your paper. See the table on page 3-3.
- Be sure your multi-part forms do not exceed 0.46 mm (0.018 inch) in thickness.
- Use multi-part forms only under normal temperature and humidity conditions, as follows:

Temperature	15 to 25°C (59 to 77°F)
Humidity	30 to 60% RH

Loading envelopes

You can load envelopes only in the top paper slot as described in "Loading Single Sheets in the Top Paper Slot" on page 3-8. Also, follow these guidelines:

- Load envelopes one at a time in the top slot, with the flap edge first and the flap side up.

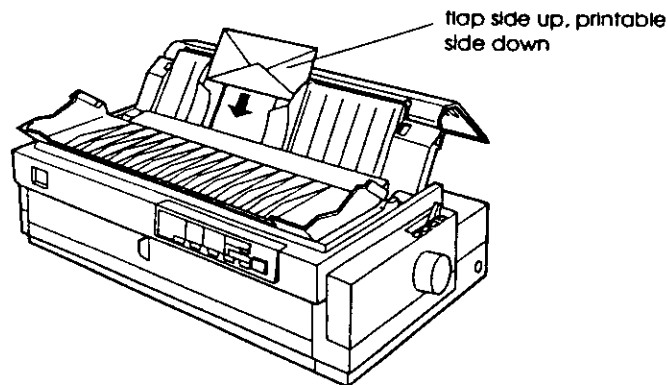

New01.eps

- Set the paper thickness lever (located under the printer cover) to position 2 or 6 to match the thickness of the envelope.
- Before printing, turn on the card mode by pressing the Tear Off/Bin button until both Tear Off/Bin lights are on. After you finish printing on envelopes, press the Tear Off/Bin button once to exit the card mode. (Bin 1 is selected.)
- Do not use envelopes that are curled or folded. Also avoid using envelopes that are too thin; they may curl during printing and become jammed.
- If you use No. 6 envelopes, align the left edge of the envelope with the arrow mark on the printer.
- Use envelopes only under normal temperature and humidity conditions, as follows:

Temperature	15 to 25°C (59 to 77°F)
Humidity	30 to 60% RH



Caution:

Because printing on the edge of an envelope may damage the print head, make sure the printing stays entirely within the printable area of your envelopes. See Appendix C for details on the printable area of envelopes.

Loading postcards

You can load postcards one at a time in the top or front paper slot as described in "Loading Single Sheets in the Top Paper Slot" (on page 3-8) or "Loading Single Sheets in the Front Paper Slot," (on page 3-10). Also, follow these guidelines:

3

- If you load postcards long edge first, always load them in the top slot.

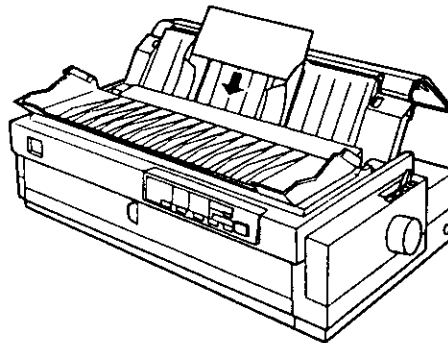

New11.eps

- Set the paper thickness lever (located under the printer cover) to position 2.
- Before printing, turn on the card mode by pressing the Tear Off/Bin button until both Tear Off/Bin lights are on. After you finish printing on postcards, press the Tear Off/Bin button once to exit the card mode. (Bin 1 is selected.)
- Use postcards only under normal temperature and humidity conditions, as follows:

Temperature	15 to 25°C (59 to 77°F)
Humidity	30 to 60% RH



Loading Single Sheets in the Top Paper Slot

To load paper in the top slot, follow these steps:

1. Make sure the paper guide is installed properly. If not, attach it as described on page 1-11.
2. Open the paper guide cover. Slide the left edge guide until it locks in place next to the arrow on the paper guide. Next adjust the right edge guide to match the width of your paper.

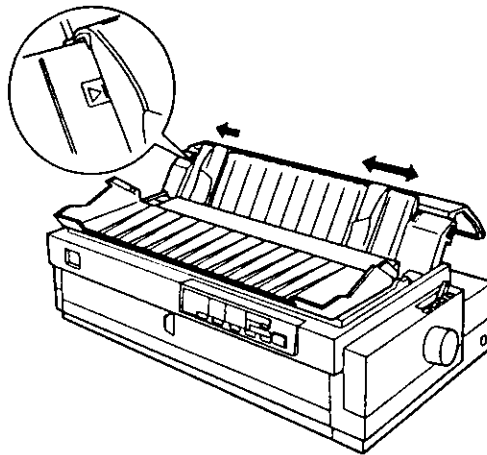

2-7n.eps

3. Set the paper release lever to the single-sheet position. Also set the paper thickness lever (located under the printer cover) to the proper position for your paper's thickness. (See the table on page 3-3.)

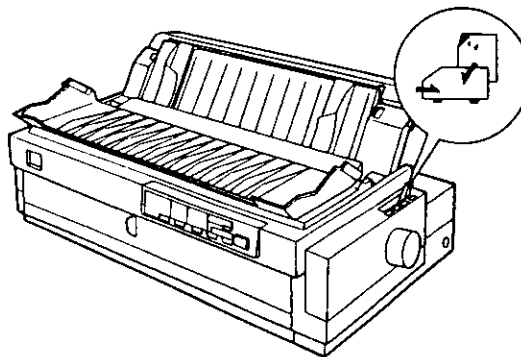

2-6.eps

Proof Sign-off:
<antoname>
<leadename>
<editname>

Sun-E+
Pre Rev. C

A5 size
8/5/98

Chap3.fm
Pass 0

R

4. Close the paper guide cover.

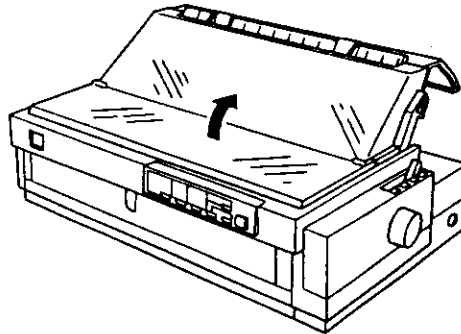

3

2-8n.eps

5. Press the Operate button to turn on the printer, if necessary.
6. Insert a sheet of paper printable side down between the edge guides until it meets resistance. The printer feeds the paper automatically and is ready to print.

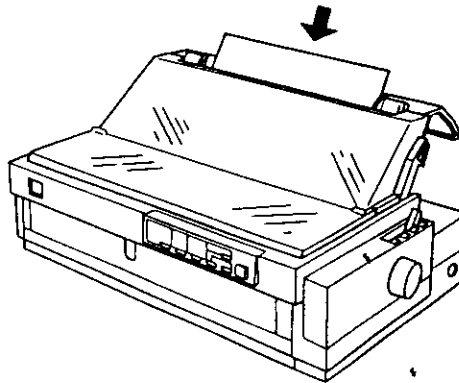

2-9n.eps

Note:

Always close the printer cover before printing. The printer does not print when the cover is open.

7. Check and change the printer driver settings as described in Chapter 4. Then send a print job to the printer.

When the printer receives data, it prints the page and ejects it back onto the paper guide. To continue printing your document, remove the printed page and insert a new sheet of paper. If you need to eject a sheet, press the Load/Eject button.

If the first printed line on your page appears too high or low, you can fix this using the micro adjust feature. See "Adjusting the Top-of-Form Position" on page 2-36.

**Caution:**

Never use the knob to adjust the top-of-form position or eject a sheet when the printer is on; this may damage the printer or cause it to lose the top-of-form position.

Loading Single Sheets in the Front Paper Slot

To load paper in the front paper slot, follow these steps:

1. Make sure the paper guide is installed properly. If not, attach it as described on page 1-11.
2. Make sure the paper guide cover is closed.

Proof Sign-off:
<antoname>
<leadename>
<editorname>



Sun-E+
Pre Rev. C

A5 size
8/5/98

Chap3.fm
Pass 0

R

3. Open the front paper guide by pulling the tab at the center of the guide. Slide the left edge guide as shown below. (Printing starts at the arrow mark.) Next adjust the right edge guide to match the width of your paper.

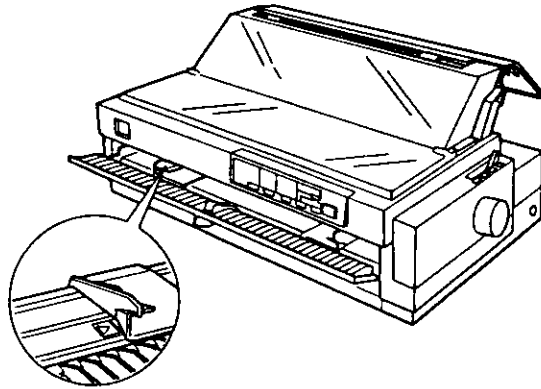

3

2-11nn.eps

4. Set the paper release lever to the single-sheet position. Also set the paper thickness lever (located under the printer cover) to the proper position for your paper's thickness. (See the table on page 3-3.)

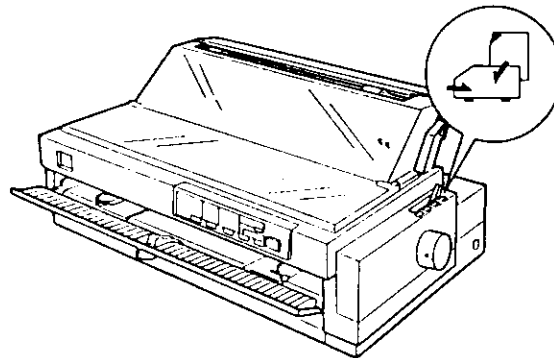

2-10a.eps

5. Press the Operate button to turn on the printer, if necessary.

6. Insert a sheet of paper printable side up between the edge guides until it meets resistance. The printer feeds the paper automatically and is ready to print.

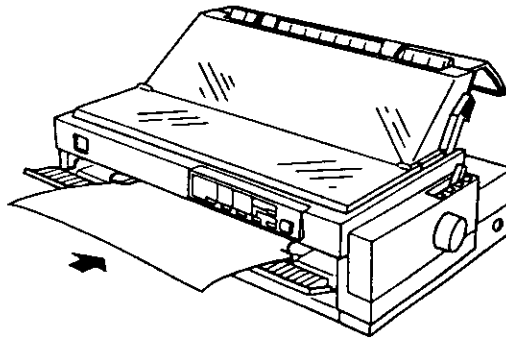

2-12.eps

Note:

Always close the printer cover before printing. The printer does not print when the cover is open.

7. You may need to check and change the printer driver settings as described in Chapter 4. Then send a print job to the printer.

When the printer receives data, it prints the page and ejects it onto the paper guide on top of the printer. To continue printing your document, remove the printed page and insert a new sheet of paper in the front paper guide. If you need to eject a sheet, press the Load/Eject button.

If the first printed line on your page appears too high or low, you can fix this using the micro adjust feature. See "Adjusting the Top-of-Form Position" on page 2-36.

**Caution:**

Never use the knob to adjust the top-of-form position or eject a sheet when the printer is on; this may damage the printer or cause it to lose the top-of-form position.

Chapter 4

Using the Printer Software

About Your Printer Software	4-2
Using the Printer Driver With Windows 95/98	4-3
Accessing the printer driver from Windows applications ..	4-3
Accessing the printer driver from the Start menu	4-5
Printer driver settings overview	4-5
Using the Printer Driver With Windows 3.1	4-9
Accessing the printer driver from Windows applications ..	4-9
Accessing the printer driver from the Control Panel	4-10
Printer driver settings overview	4-11
Using the Printer Driver With Windows NT 4.0	4-13
Accessing the printer driver from Windows applications ..	4-13
Accessing the printer driver from the Start menu	4-15
Printer driver settings overview	4-15
Using the Printer Driver With Windows NT 3.5x	4-19
Accessing the printer driver from Windows applications ..	4-19
Accessing the printer driver from the Control Panel	4-21
Printer driver settings overview	4-22
Using the EPSON Remote! Utility	4-24
Installing EPSON Remote!	4-24
Accessing EPSON Remote!	4-24



About Your Printer Software

The EPSON printer software that comes with your printer includes the printer driver software, the EPSON Remote! utility, and the EPSON Status Monitor 2 utility for Windows 95/98.

As described in Chapter 1, a printer driver is software that allows your computer to control the printer. You need to install the printer driver so your Windows software applications can take full advantage of the printer's capabilities.

Note:

Before proceeding, make sure you have installed the printer driver on your PC as described in Chapter 1.

EPSON Remote! is a DOS-based printer setup utility that allows you to easily change the printer's default settings from the computer screen. To use the EPSON Remote! utility with DOS, see page 4-24.

The EPSON Status Monitor 2 utility program is available only for Windows 95. It monitors the status of your printer, alerts you when errors occur, and provides you with troubleshooting tips. To install and use the Status Monitor, see Chapter 6, "Using EPSON Status Monitor 2."

To use the printer driver, see the appropriate page below, depending on your Windows version.

Windows 95/98	4-3
Windows 3.1	4-9
Windows NT 4.0	4-13
Windows NT 3.5x	4-19

Proof Sign-off:
<antoname> _____
<leadename> _____
<editomame> _____

Sun-E+
Pre Rev. C

A5 size
8/5/98

Chap4.fm
Pass 0

R

Using the Printer Driver With Windows 95/98

There are two ways to access the printer driver: from your Windows applications or from the Start menu. When you access the printer driver from a Windows application, any settings you make apply only to the application you are using. See "Accessing the printer driver from Windows applications," below. When you access the printer driver from the Start menu, the printer driver settings you make apply to all your applications. See "Accessing the printer driver from the Start menu," on page 4-5. To check and change printer driver settings, see "Printer driver settings overview" on page 4-5.

4

Note:

While many Windows applications override the settings made with the printer driver, some do not; so you must verify that the printer driver settings match your requirements.

Accessing the printer driver from Windows applications

To access the printer driver from a Windows application, follow the steps below.

Note:

The steps below provide general guidelines on accessing the printer driver. How you access the printer driver may differ depending on your application. See your application manual for details.

L

Sun-E+
Pre Rev. C

A5 size
8/5/98

Chap4.fm
Pass 0

Proof Sign-off:
<antname> _____
<leadname> _____
<editname> _____

1. Select Print Setup or Print from the File menu of your application software. The Print or Print Setup dialog box appears.

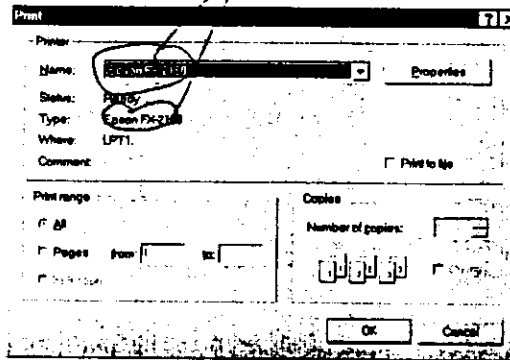

95d.tif

2. Make sure that your printer is selected and then click Printer, Setup, Properties, or Options. (You may need to click a combination of these buttons.) The Properties window appears, and you see the Paper, Graphics, and Device Options menus. These menus contain the printer driver settings.

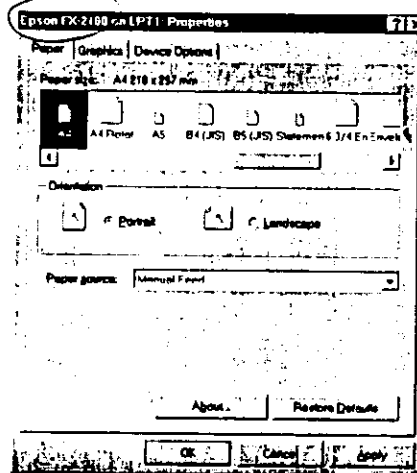

95.tif

3. To view a menu, click the corresponding tab at the top of the window. See "Printer driver settings overview," below for detailed information about the settings.

Accessing the printer driver from the Start menu

To access the printer driver from the Start menu, follow these steps:

1. Click the Start button, and then point to Settings.
2. Click Printers.
3. Right-click your printer icon, and click Properties. The screen displays the Properties window, which contains the Paper, Graphics, and Device Options menus. These menus provide the printer driver settings.
4. To view a menu, click the corresponding tab at the top of the window. See the next section for detailed information about the printer driver settings.



Printer driver settings overview

Your printer driver has three menus: Paper, Graphics, and Device Options. The printer driver settings on each of these menus are described below. To open the menus, see the previous sections on accessing the printer driver.

When you finish making your printer driver settings, click OK to apply the settings, or click Restore Defaults to return the settings to their previous values.

L

Sun-E+
Pre Rev. C

A5 size
18/5/98

Chap4.fm
Pass 0

Proof Sign-off:
<antname>
<leadname>
<editname>

Paper menu

EPSON
LQ-2180
変更

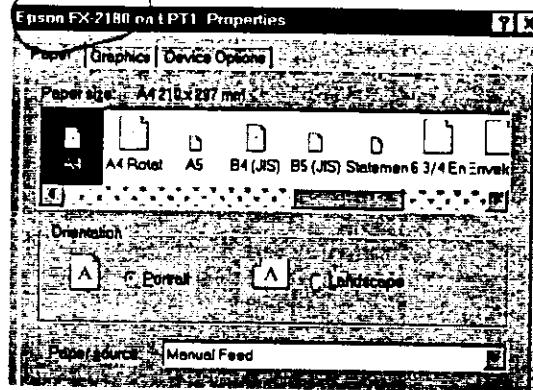

95paper1.tif

- Paper size Select the size of the paper you want to use. If you don't see your paper size, use the scroll bar to scroll through the list. If your paper size is not included in the list, click Custom and enter the paper size in the dialog box that appears.
- Orientation Select Portrait or Landscape.
- Paper source Click the paper source you want to use.

Proof Sign-off:
<tantoname>
<leadename>
<editoname>



Sun-E+
Pre Rev. C

A5 size
8/5/98

Chap4.fm
Pass 0

R

Graphics menu

LR-2180に変更

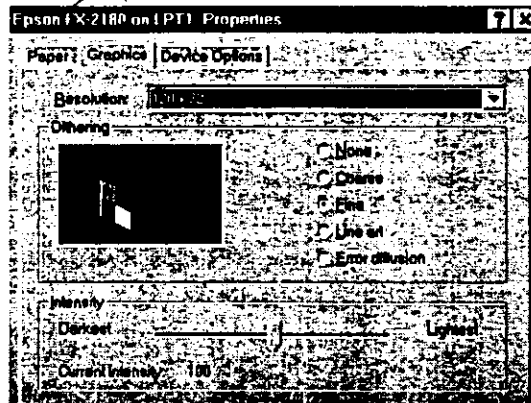

95graphi.tif

4

- Resolution Click the printing resolution you want. The higher the resolution you select, the more detailed your printout will be; however, increasing the resolution slows printing.

- Dithering You can leave this option set to Fine, which is the default setting, or select another dithering pattern depending on the kind of printout you want. The display to the left of the dithering options shows the effect of your setting.

- Intensity Move the slider to make your printout lighter or darker.

L

Sun-E+
Pre Rev. C

A5 size
18/5/98

Chap4.fm
Pass 0

Proof Sign-off: _____
<antname> _____
<leadname> _____
<editname> _____

Device Options menu

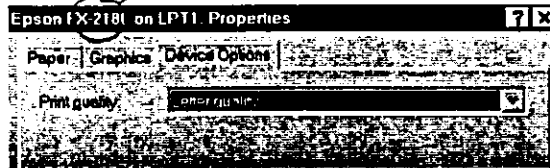

95device.tif

- Print quality** Select a print quality option from the Print quality list. Selecting a high quality option produces more detailed printouts at a slower printing speed.

Once you've checked your printer driver settings and changed them if necessary, you are ready to print with continuous paper as described in Chapter 2, or with single sheets as described in Chapter 3.

Using the Printer Driver With Windows 3.1

There are two ways to access the printer driver: from your Windows applications or from the Control Panel. When you access the printer driver from a Windows application, any settings you make apply only to the application you are using. See "Accessing the printer driver from Windows applications," below. When you access the printer driver from the Control Panel, the printer driver settings you make apply to all your applications. See "Accessing the printer driver from the Control Panel," on page 4-10. To check and change printer driver settings, see "Printer driver settings overview" on page 4-11.

4

Note:

While many Windows applications override the settings made with the printer driver, some do not; so you must verify that the printer driver settings match your requirements.

Accessing the printer driver from Windows applications

To access the printer driver from a Windows application, follow the steps below.

Note:

The steps below provide general guidelines on accessing the printer driver. How you access the printer driver may differ depending on your application. See your application manual for details.

1. Select Print Setup or Print from the File menu of your application software. The Print or Print Setup dialog box appears. See "Printer driver settings overview" on the next page for detailed information about the settings in this dialog box.

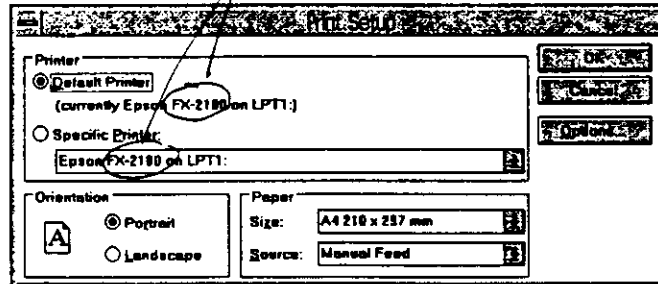

Print.tif

2. Make sure that your printer is selected and then click Printer, Setup, or Options. (You may need to click a combination of these buttons.) The Options dialog box appears. See page 4-11 for detailed information about the settings in this dialog box.

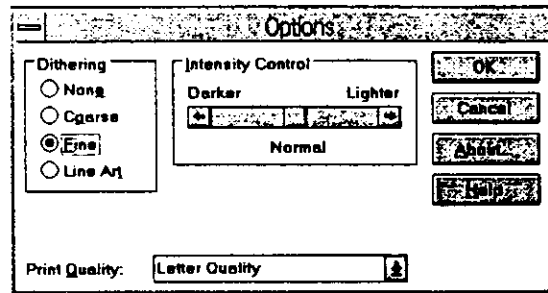

Options.tif

Accessing the printer driver from the Control Panel

To access the printer driver from the Control Panel, follow these steps:

1. In the Main window, double-click the Control Panel icon.

2. Double-click the Printers icon. The Printers dialog box appears.
3. Make sure your printer is highlighted, then click Setup. The Print Setup dialog box appears. To access more settings, you may need to click Options. See the next section for detailed information about the printer driver settings.

Printer driver settings overview

The printer driver settings are described below. To access the printer driver settings, see the previous sections on accessing the printer driver.

4

When you finish making your printer driver settings, click OK to apply the settings, or click Cancel to cancel your changes.

Print or Print Setup dialog box

- Resolution Click the printing resolution you want. The higher the resolution you select, the more detailed your printout will be; however, increasing the resolution slows printing. This setting is available only from the Control Panel.
- Orientation Select Portrait or Landscape. The diagram on the screen shows the orientation you select.
- Paper Size Select the size of the paper you want to use. If you don't see your paper size, use the scroll bar to scroll through the list. If your paper size is not included in the list, click User Defined Size and enter the paper size in the dialog box that appears.
- Paper Source Click the paper source you want to use.

Options dialog box

- Dithering** You can leave this option set to Fine, which is the default setting, or select another dithering pattern depending on the kind of printout you want.
- Intensity Control** Move the slider to make your printout lighter or darker.
- Print Quality** Select a print quality option from the Print Quality list. Selecting a high quality option produces more detailed printouts at a slower printing speed.

Once you've checked your printer driver settings and changed them if necessary, you are ready to print with continuous paper as described in Chapter 2, or with single sheets as described in Chapter 3.

Using the Printer Driver With Windows NT 4.0

There are two ways to access the printer driver: from your Windows applications or from the Start menu. When you access the printer driver from a Windows application, any settings you make apply only to the application you are using. See "Accessing the printer driver from Windows applications," below. When you access the printer driver from the Start menu, the printer driver settings you make apply to all your applications. See "Accessing the printer driver from the Start menu," on page 4-15. To check and change printer driver settings, see "Printer driver settings overview" on page 4-15.

4

Note:

While many Windows applications override the settings made with the printer driver, some do not; so you must verify that the printer driver settings match your requirements.

Accessing the printer driver from Windows applications

To access the printer driver from a Windows application, follow the steps below.

Note:

The steps below provide general guidelines on accessing the printer driver. How you access the printer driver may differ depending on your application. See your application manual for details.

L

Sun-E+
Pre Rev. C

A5 size
8/5/98

Chap4.fm
Pass 0

Proof Sign-off:

<antname> _____

<leadname> _____

<editname> _____

1. Select Print Setup or Print from the File menu of your application software. The Print or Print Setup dialog box appears.

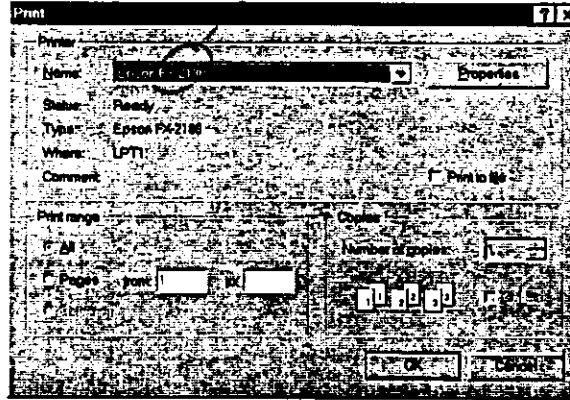

95d.tif

2. Make sure that your printer is selected and then click Printer, Setup, Properties, or Options. (You may need to click a combination of these buttons.) The Document Properties window appears, and you see the Page Setup and Advanced menus. These menus contain the printer driver settings.

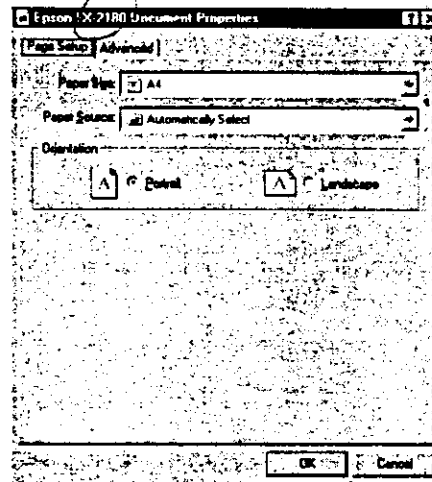

Nt40pr.tif

3. To view a menu, click the corresponding tab at the top of the window. See "Printer driver settings overview," below for detailed information about the settings.

Accessing the printer driver from the Start menu

To access the printer driver from the Start menu, follow these steps:

1. Click the Start button, and then point to Settings.
2. Click Printers.
3. Right-click your printer icon, and click Document Defaults. The screen displays the Default Document Properties window, which contains the Page Setup and Advanced menus. These menus provide the printer driver settings.
4. To view a menu, click the corresponding tab at the top of the window. See the next section for detailed information about the printer driver settings.

4

Printer driver settings overview

Your printer driver has two menus: Page Setup and Advanced. The printer driver settings on each of these menus are described below. To open these menus, see the previous sections on accessing the printer driver.

When you finish making your printer driver settings, click OK to apply the settings, or click Cancel to cancel your changes.

L

Sun-E+
Pre Rev. C

A5 size
18/5/98

Chap4.fm
Pass 0

Proof Sign-off:
<tantoname>
<leadername>
<editorname>

Page Setup menu

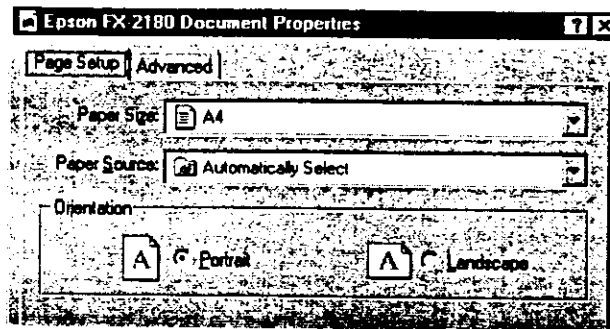

Nt40pr2.tif

- Paper Size Select the size of the paper you want to use from the Paper Size list.
- Paper Source Select the paper source you want to use from the Paper Source list.
- Orientation Select Portrait or Landscape.

Advanced menu

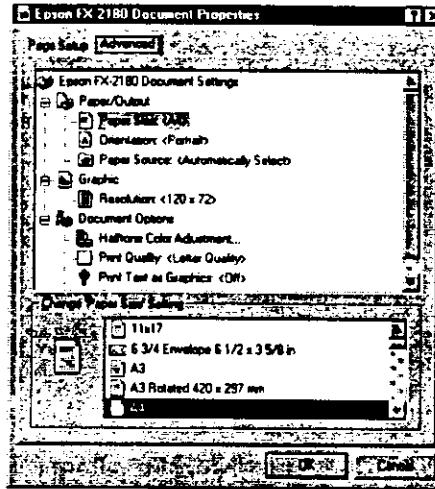

Nt40od.ttf

4

- Paper/Output Check the Paper Size, Orientation, and Paper Source settings you made on the Page Setup menu and change them if necessary. Select the setting and then choose an option from the Change Setting list box.

- Graphic Select Resolution and then choose the printing resolution from the Change Setting list box. The higher the resolution you select, the more detailed your printout will be; however, increasing the resolution slows printing.

L

Sun-E+
Pre Rev. C

A5 size
8/5/98

Chap4.fm
Pass 0

Proof Sign-off:
<stantname>
<leadername>
<editorname>

- Document Options

Double-click Halftone Color Adjustment to open the Halftone Color Adjustment dialog box. Click Print Quality to select a print quality option. Click Print Text as Graphics or Metafile Spooling and select On or Off in the Change Setting list box.

Once you've checked your printer driver settings and changed them if necessary, you are ready to print with continuous paper as described in Chapter 2, or with single sheets as described in Chapter 3.

Using the Printer Driver With Windows NT 3.5x

There are two ways to access the printer driver: from your Windows applications or from the Control Panel. When you access the printer driver from a Windows application, any settings you make apply only to the application you are using. See "Accessing the printer driver from Windows applications," below. When you access the printer driver from the Control Panel, the printer driver settings you make apply to all your applications. See "Accessing the printer driver from the Control Panel," on page 4-21. To check and change printer driver settings, see "Printer driver settings overview" on page 4-22.

4

Note:

While many Windows applications override the settings made with the printer driver, some do not; so you must verify that the printer driver settings match your requirements.

Accessing the printer driver from Windows applications

To access the printer driver from a Windows application, follow the steps below.

Note:

The steps below provide general guidelines on accessing the printer driver. How you access the printer driver may differ depending on your application. See your application manual for details.

1. Select Print Setup or Print from the File menu of your application software. The Print or Print Setup dialog box appears.

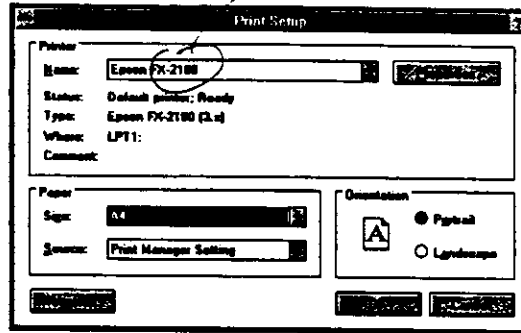

Print35.tif

2. Make sure that your printer is selected and then click Printer, Setup, Properties, or Options. (You may need to click a combination of these buttons.) The screen displays the Document Properties dialog box, which contains the Form and Orientation printer driver settings. See "Printer driver settings overview" on the page 4-22 for detailed information about these settings.

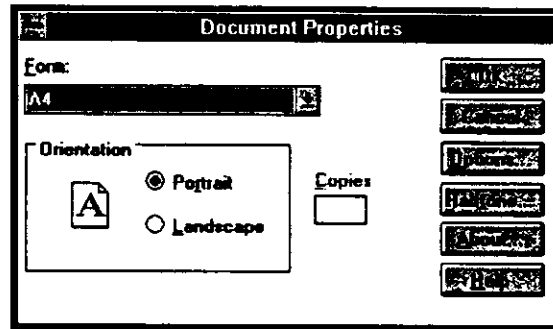

Doc35.tif



3. Click Options (or a similar button) to view the Advanced Document Properties dialog box, which includes the Graphics Resolution, Color, and Optimizations printer driver settings. See page 4-22 for detailed information about these settings.

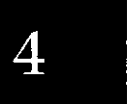
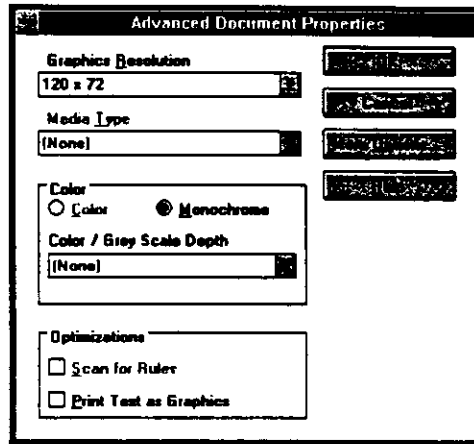

Advan35.tif

Accessing the printer driver from the Control Panel

To access the printer driver from the Control Panel, follow these steps:

1. In the Main window, double-click the Print Manager icon. The Print Manager window opens.
2. Make sure your printer is highlighted, then click Printer and select Properties. The Printer Properties dialog box appears.
3. Click the Details button, then click Job Default. You see the Document Properties dialog box, which includes the Form and Orientation printer driver settings. See the next section for detailed information about these settings.

4. Click Options to open the Advanced Document Properties dialog box, which contains the Graphics Resolution, Color, and Optimization printer driver settings. See the next section for detailed information about these settings.

Printer driver settings overview

Your printer driver has two dialog boxes: Document Properties and Advanced Document Properties. The printer driver settings in each of these dialog boxes are described below. To open these dialog boxes, see the previous sections on accessing the printer driver.

When you finish making your printer driver settings, click OK to apply the settings, or click Cancel to cancel your changes.

Document Properties dialog box

- Form Select the type of paper you want to use. If you don't see your paper type, select it from the Form list.
- Orientation Select Portrait or Landscape. The diagram on the screen shows the orientation you select.

Click the Halftone button to set the brightness and contrast, input the RGB gamma, or make other settings. The Halftone Color Adjustment dialog box appears. For details, click Help in this dialog box.

Advanced Document Properties dialog box

- Graphics Resolution** Select a printing resolution option from the Graphics Resolution list. The higher the resolution you select, the more detailed your printout will be; however, increasing the resolution slows printing.
- Color** Only monochrome printing is available.
- Optimizations** Click a check box to turn the corresponding option on or off.
- Print Quality** To select the print quality, click the More Options button. The More Options dialog box appears. Selecting a high quality option produces more detailed printouts at a slower printing speed.



Once you've checked your printer driver settings and changed them if necessary, you are ready to print with continuous paper as described in Chapter 2, or with single sheets as described in Chapter 3.

Using the EPSON Remote! Utility

The EPSON Remote! utility allows you to easily change the printer's default settings from your computer's DOS prompt.

Installing EPSON Remote!

Follow the steps below to install EPSON Remote!

1. Insert printer software CD-ROM in a disk drive.
2. At the DOS prompt, type D:\SETUP. (If you inserted the disk in a drive other than drive D, substitute the appropriate letter.) Then press Enter.
3. Select your printer's name in the Printer Model window and press Enter. C:\EPUTIL appears as the default directory.
4. Press Enter again. The EPSON Remote! utility is copied to the C:\EPUTIL directory.

Accessing EPSON Remote!

To access EPSON Remote!, type C:\PRNSET at the DOS prompt and press Enter. Then follow the on-screen instructions to use this utility. You can also access EPSON Remote! by typing C:\PANEL at the DOS prompt and pressing Enter. The PRNSET and PANEL access methods differ slightly in that the PANEL method opens a condensed version of EPSON Remote! that only provides the most often used settings.

Proof Sign-off:
<antoname> _____
<leadename> _____
<editoname> _____

Sun-E+
Pre Rev. C

A5 size
8/5/98

Chap5.fm
Pass 0

R

Chapter 5

***Changing Printer Settings From the
Printer's Control Panel***

Selecting a Built-In Font and Pitch 5-2
About Your Printer's Default Settings 5-4
 Changing default settings 5-9

5

Selecting a Built-In Font and Pitch

Your printer comes with the twelve built-in fonts shown in the table below. You can also choose from the following six pitch (character size) settings: 10, 12, 15, 17, or 20 cpi (characters per inch), or proportional spacing. You can select the font and pitch using the buttons on the printer's control panel as described below.

Note:

Settings you make in your application programs usually override settings you make from the printer's control panel. For best results, use your application to select a font and pitch.

Font	Sample
Draft	
Roman	
Sans Serif	
Courier	
Prestige	
Script	
OCR-B	
Orator	
Orator-S	
Script C	
Roman T	
San Serif H	

} 新
燈
耐
心

Follow these steps to select a built-in font or pitch using the buttons on the printer's control panel:

1. Make sure that the printer is not printing. If it is, press the Pause button to stop printing.



2. To select a font, press the Font button until the two Font lights indicate the font you want as shown below.

Font lights	Font
■ ■ □	Draft
■ □ ■	Roman
■ □ □	Sans Serif
□ ■ ■	Courier
□ ■ □	Prestige
■ □ □	Script
□ □ □	Others

□ = On, ■ = Off

* others means the font selected in the default-setting mode

5

Note:

The Font button cannot directly select OCR-B, Orator, Orator-S, Script-C, Roman-T, or Sans Serif H. To select one of these fonts, you must first use the default-setting mode to register it as the "other" font. Note that the default "other" setting is Roman-T.

To select a pitch, press the Pitch button until the three Pitch lights indicate the pitch you want as shown below.

Pitch lights	Pitch
■ ■ □	10 cpi
■ □ ■	12 cpi
■ □ □	15 cpi
□ ■ ■	17 cpi
□ ■ □	20 cpi
□ □ ■	PS (proportional spacing)

□ = On, ■ = Off

About Your Printer's Default Settings

The printer's default settings control many printer functions. While you can often set these functions through your software or printer driver, you may sometimes need to change a default setting from the printer's control panel using the default-setting mode.

The following table lists the default settings and the options you can select in the default-setting mode. The settings are explained in detail after the table. For instructions on changing the default settings, see page 5-9.

Settings	Options
Page length for front tractor*	Length in inches: 3, 3.5, 4, 5.5, 6, 7, 8, 8.5, 11, 70/6, 12, 14, 17 inches
Page length for rear tractor*	Length in inches: 3, 3.5, 4, 5.5, 6, 7, 8, 8.5, 11, 70/6, 12, 14, 17 inches
Skip over perforation	On, Off
Auto tear off	On, Off
Auto line feed	On, Off
Print direction	Auto, Bi-D, Uni-D
I/F mode	Auto, Parallel, Optional
Auto I/F wait time	10 seconds, 30 seconds
Software	ESC/P2, IBM 2391 Plus
Character table	Standard model: Italic, PC 437, PC 850, PC 858, PC 860, PC 863, PC 865, PC 861, BRASCII, Abicomp, ISO 8859-15, ISO Latin 1, Roman 8 All other models: Italic, PC 437, PC 437 Greek, PC 850, PC 852, PC 853, PC 855, PC 857, PC 858, PC 863, PC 864, PC 866, PC 869, BRASCII, Abicomp, ISO Latin 1, ISO Latin 1T, ISO 8859-7, ISO 8859-15, MAZOWIA, Code MJK, Bulgaria, Estonia, PC 774, PC 866 UKR, ISO 8859-2, PC 866 LAT, PC APTEC, PC 708, PC 720, PC AR864, PC 860, PC 861, PC865, Roman 8.

PC 858
ISO 8859-15
の追加

PC 864 の追加

Proof Sign-off:
<antoname>
<leadname>
<editname>

Sun-E+
Pre Rev. C

A5 size
8/5/98

Chap5.fm
Pass 0

R

Settings	Options
International character set for Italic table	Italic U.S.A., Italic France, Italic Germany, Italic U.K., Italic Denmark I, Italic Sweden, Italic Italy, Italic Spain I
0 slash	On, Off
High speed draft	Off, On
Input buffer	On, Off
Buzzer	On, Off
Auto CR (IBM 2391Plus)**	On, Off
A.G.M. (IBM 2391Plus) **	On, Off
Font	OCR-B, Orator, Orator-S, Script C, Roman T, Sans Serif H
Roll paper	On, Off

5

* The options available vary depending on the country.

**These settings take effect only when IBM 2391 Plus emulation is selected.

Page length for front tractor

This setting allows you to set the page length (in inches) for continuous paper loaded on the front push tractor.

Page length for rear tractor

This setting allows you to set the page length (in inches) for continuous paper loaded on the rear push tractor.

Skip over perforation

This setting takes effect only when you are using continuous paper. When you select On, the printer provides a one-inch (25.4 mm) margin between the last line printed on one page and the first line printed on the next page. Because most application programs override margin settings made from the control panel, you should use this setting only if you cannot set your top and bottom margins using your application.

Auto tear off

When you turn on this setting and print on continuous paper with the front or rear push tractor, the printer automatically advances the paper perforation to the tear-off position, where you can easily tear off the printed page(s). When the printer receives the next print job, it automatically moves the unused paper back to the top-of-form position and starts printing, so no paper is wasted between print jobs.

When you select Off and print on continuous paper with the front or rear push tractor, you need to move the perforation to the tear-off position manually by pressing the Tear Off/Bin button. See "Advancing the Paper to the Tear-Off Edge" in Chapter 2 for more information. (The tear-off feature is not available for paper loaded on the pull tractor.)

Auto line feed

When you turn on this setting, each carriage return (CR) code received by the printer is accompanied by a line feed code. This moves the print position to the beginning of the next line. If the printer adds an extra line after every carriage return, select Off.

Print direction

You can choose automatic print direction selection, bidirectional printing (Bi-D), or unidirectional printing (Uni-D). Printing is normally bidirectional; however, unidirectional printing allows for precise vertical printing alignment, which is useful for printing graphics.

I/F (interface) mode

The printer comes with a built-in parallel interface and an interface slot in which you can install one optional interface. For information on using an optional interface, see page A-3.

If your printer is connected to only one computer, select Parallel or Optional for the interface mode, depending on the interface you use. If your printer is connected to more than one computer, select Auto (automatic) for the interface mode to cause the printer to automatically switch between interfaces depending on which one is receiving data.

Auto I/F (interface) wait time

This setting takes effect only if an optional interface is installed and the auto interface mode is selected. This setting determines how long the printer waits when it no longer receives data from an interface before it checks whether a print job is being sent through the other interface. You can specify 10 seconds or 30 seconds for the auto interface wait time.

5

Software

If you select ESC/P2, the printer operates in the EPSON ESC/P2 mode. If you select IBM 2391 Plus, the printer emulates an IBM printer.

Character table

You can select among 11 standard character tables as well as tables for 26 other countries. See Appendix C for character samples.

International character set for Italic table

You can select among several international character sets for the Italic character table. Each character set contains eight characters that vary depending on the country or language, so you can customize the Italic table to suit your printing needs. See Appendix C for character samples.

0 slash

When you turn on this setting, the zero character contains a slash (0); otherwise it has no slash (0). The slash allows you to easily distinguish between the uppercase letter "O" and a zero.

High speed draft

When you choose On, the printer prints up to 480 cps (characters per second) at 10 cpi (characters per inch). When you choose Off, the printer prints up to 360 cps at 10 cpi.

Input buffer

When you turn on this setting, the printer's input buffer stores up to 64KB of data sent from your computer, freeing up your computer for other tasks while the printer prints. When you select Off, the buffer cannot store data, so the computer must wait for the printer to print each character before it sends the next character.

Buzzer (beeper)

When you turn on this setting, the printer beeps when an error occurs. See page 7-2 for more information on printer errors. If you do not want the printer to beep when an error occurs, select Off.

Auto CR (carriage return)

This setting is available only in IBM 2391 Plus emulation mode. When you select On, each line feed (LF) code or ESC J code received by the printer is accompanied by a carriage return code. This moves the print position to the beginning of the next line. If the printer adds an extra line after every carriage return, select Off.

A.G.M. (Alternate Graphic Mode)

When A.G.M. is on, the printer can use some advanced graphics commands like those available in ESC/P2 mode. When you select IBM 2391 mode, this setting is available. The default setting is off.

Font

You can select 6 fonts in default-setting mode. The following fonts are indicated on the control panel and can't be selected by default settings: Draft, Roman Sans Serif, Courier, Prestige, and Script.

Roll paper

When you turn on this mode, the printer recognizes that the paper is not single sheets, so it does not try to eject the paper and advance it forward to the next page when you press the LF/FF button.

Changing default settings

Follow the steps below to enter the default-setting mode and change the printer's default settings.

Note:

- To print the language selection and default-setting mode instructions, you need three sheets of A4- or letter-size single-sheet paper or three pages of continuous paper that is at least 279 mm (11 inches) long and 210 mm (8.27 inches) wide. See Chapter 2 for instructions on loading continuous paper, or Chapter 3 for instructions on loading single sheets.*
 - If you use single sheets, you need to load a new sheet of paper each time the printer ejects a printed sheet.*
1. Make sure paper is loaded and the printer is turned off.



Caution:

Whenever you turn off the printer, wait at least five seconds before turning it back on; otherwise you may damage the printer.

2. Hold down the Pitch button while you press the Operate button to turn on the printer. The printer enters the default-setting mode and prints the language selection instructions (one page).
3. Press the Pitch button until the Pitch lights indicate the language you want, as described in the language selection instructions.



4. Press the FONT button to print the default-setting mode instructions (two pages) in the language you selected.

The printed instructions list the default settings you can change, describe how to change them, and show you how the control panel lights help you make settings. Follow these instructions to change the default settings using the buttons on the printer's control panel.

Note:

The arrows on the instruction sheets indicate the printer's current settings.

5. When you finish making settings, press the Operate button to turn off the printer and exit the default-setting mode. Any settings you have made remain in effect until you change them again.

Note:

You may exit the default-setting mode by turning off the printer while the printer is not printing.

Proof Sign-off:
<antoname> _____
<leadename> _____
<editomame> _____

Sun-E+
Pre Rev. C

A5 size
8/5/98

Chap6.fm
Pass 0

R

Chapter 6

Using EPSON Status Monitor 2

About the EPSON Status Monitor 2 Utility	6-2
Installing EPSON Status Monitor 2	6-3
Accessing EPSON Status Monitor 2	6-4
Checking Printer Status Information	6-4
Using the EPSON Status Monitor 2 window	6-4
Using the Printer Status window	6-9
Making Monitoring Preference Settings	6-10
Turning on background monitoring	6-11
Using the background monitoring icon	6-12

6

L

Sun-E+
Pre Rev. C

A5 size
8/5/98

Chap6.fm
Pass 0

Proof Sign-off:

<antname>

<leadname>

<editname>

About the EPSON Status Monitor 2 Utility

The EPSON Status Monitor 2 utility comes with your printer but is available only for use with Microsoft Windows 95/98. It allows you to monitor your printer's status, alerts you when printer errors occur, and provides troubleshooting instructions when needed.

The EPSON Status Monitor 2 will be installed together with the printer driver when the printer software is installed.) 追加

Note:

To monitor an LQ-2180 printer on a network, you must install an optional Ethernet interface card (C82357*/C82362*/C82364*) in your printer and use the Status Monitor utility that comes with this card. See the manual that comes with the interface card for instructions on using the Status Monitor in a network environment. OK-アカ?

Before using the Status Monitor, be sure to read the README file on Disk 1 of the EPSON Status Monitor 2 software. You can also find this README file in the EPSON Status Monitor 2 folder, located in the EPSON folder on your hard drive. This file contains the latest information on the Status Monitor.

Installing EPSON Status Monitor 2

Note:

If you installed the EPSON Status Monitor 2 when you installed the printer software, you do not need to install again.

Noteを
書きかえ
ました。

To install the Status Monitor, follow these steps:

1. Make sure Windows is running. Insert the printer software CD-ROM in the CD-ROM drive. (For printer software floppy disk users, insert the floppy disk in a disk drive.)
2. If a dialog box appears, click Quit.
3. Click Start, and select Run.
4. Type D:\ and specify your preferred language by typing English, French, German, Italian, Portugal, or Spanish followed by \status2.
5. Click OK, then follow the instructions on the screen.

ステップの方法
が 変わりました。

6

Note:

If the dialog box below appears, and if your printer is connected directory to your computer, select Monitor local printers. If it is connected through a network, select Monitor Windows shared printers. Then click Next.

After you install EPSON Status Monitor 2 and restart your computer, the Status Monitor starts automatically and adds a printer-shaped background monitoring icon to the taskbar at the bottom of your computer screen. This icon appears only when the Status Monitor is active.

? NG ?

Accessing EPSON Status Monitor 2

To open the EPSON Status Monitor 2 window shown below, double-click the printer-shaped background monitoring icon on the taskbar at the bottom of your computer screen. You can also open this window from Start. Click Start, point to Programs and Epson, then click EPSON Status Monitor 2.

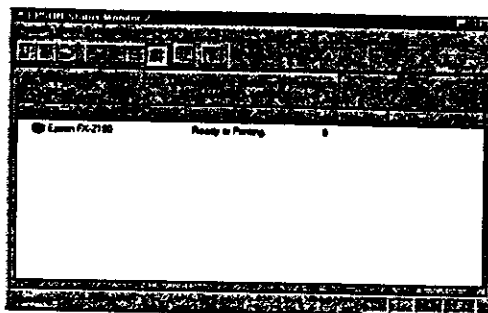

Status.tif

Checking Printer Status Information

This section describes how to use the Status Monitor to get general and detailed printer status information.

Using the EPSON Status Monitor 2 window

You can select many Status Monitor menu commands by clicking the buttons on the toolbar from this window. When you point to a toolbar button, the corresponding menu command appears briefly on your screen, and you see an explanation of the button's function in the status bar at the bottom of the EPSON Status Monitor 2 window.

The main features of the EPSON Status Monitor 2 window are described below.

Installed Printers list

This list displays information about the EPSON printers connected directly to your computer. If you select **List** from the **View** menu, the list displays only the printer names and icons. If you select **Details**, the list displays the printer name, status, and job count of each printer.

When you install the Status Monitor, it automatically adds to this list the names and icons of all the EPSON printers connected to your computer. To add or delete a printer from the list, select **Add Printer** or **Delete Printer** from the **Settings** menu. To save computer memory, delete any printers you do not need to monitor. (Doing so does not remove the printer driver from your computer.)

The appearance of the icon next to each printer name changes depending on the printer's status, as described in the table below. See online help for more information.

6

Icon appearance	Description
Green	The printer is ready to print, or currently printing.
Yellow	The printer needs routine maintenance.
Red	A printer error has occurred and your printer cannot print. See Chapter 7 for troubleshooting information.
Dimmed	There is a communication problem between the printer and the Status Monitor.

The **Status** column of the **Installed Printers** list displays brief messages describing the current status of each printer, and the **Job Count** column displays the number of jobs waiting to print on each printer.

Note:

You can arrange the printers in the Installed Printers list according to the information in the Printer Name, Status, or Job Count column. Click the Printer Name, Status, or Job Count title bar to change the printer order.

Printer menu

To get detailed information on the status of each printer in the Installed Printers list, select a printer from the list, then select from the Printer menu options described below.

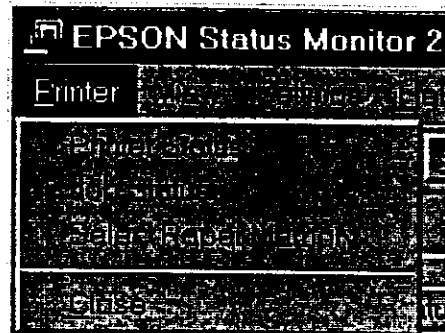

Sprint.tif

- | | |
|--|--|
| <input type="checkbox"/> Printer Status | Opens the Printer Status window, which provides detailed information on the selected printer's status. To use the Printer Status window, see page 6-9. |
| <input type="checkbox"/> Job Status | Provides information about the jobs waiting to print on the selected printer. |
| <input type="checkbox"/> Select Paper Memory | Not available. |
| <input type="checkbox"/> Close | Closes the EPSON Status Monitor 2 window. |

View menu

To control the appearance and content of the EPSON Status Monitor 2 window and the Installed Printers list, select from the View menu options described below.

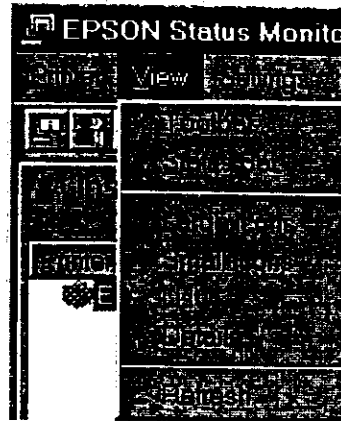

Sview.tif

6

- Toolbar/Status Bar** Shows or hides the toolbar and status bar in the EPSON Status Monitor 2 window.
- Large Icons/Small Icons** Changes the size of the printer icons in the Installed Printers list.
- List** Displays only the printer names and icons in the Installed Printers list.
- Details** Displays the printer name and icon, status, and number of jobs waiting to print for each printer in the Installed Printers list.
- Refresh** Updates the printer status information shown in the Installed Printers list.

Settings menu

Use the Settings menu options described below to adjust the monitoring interval for the printer, add and delete printers from the Installed Printers list, or activate the Status Monitor.

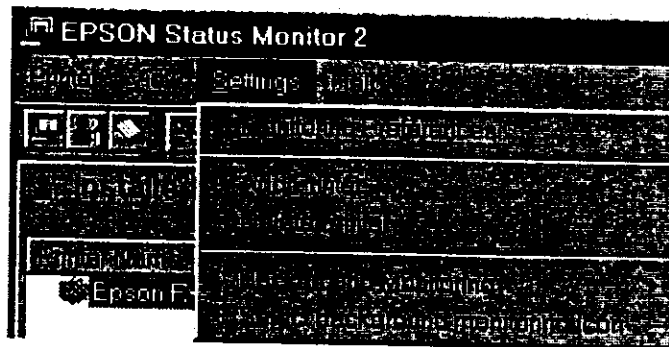

Ssetting.tif

- Monitoring Preferences** Opens the Monitoring Preferences dialog box, where you can adjust the monitoring interval and make background monitoring settings for the selected printer. For more information, see "Turning on background monitoring" on page 6-11.
- Add Printer/ Delete Printer** Allows you to select the printers you want to monitor by adding or deleting printers in the Installed Printers list.
- Background Monitoring** Activates the Status Monitor. (A printer-shaped icon appears on the taskbar at the bottom of your computer screen.)

Note:

The Background Monitoring and Status Alert settings in the Monitoring Preferences dialog box are not available while the Status Monitor is inactive.

- Select background monitoring icon

Changes the appearance of the icon that is displayed on the taskbar when background monitoring is active.

Help menu

Click Help in the EPSON Status Monitor 2 window to view online help. Click About to view the Status Monitor's version number and copyright information.

Using the Printer Status window

You can open the Printer Status window shown below to see detailed information on the status of a printer. To open the Printer Status window, double-click a printer in the Installed Printers list, or select a printer and then choose Printer Status from the Printer menu of the EPSON Status Monitor 2 window. You can also access the Printer Status window by clicking the Details button in the Status Alert dialog box. For information on the Status Alert dialog box, see "Making Monitoring Preference Settings" on page 6-10.

6

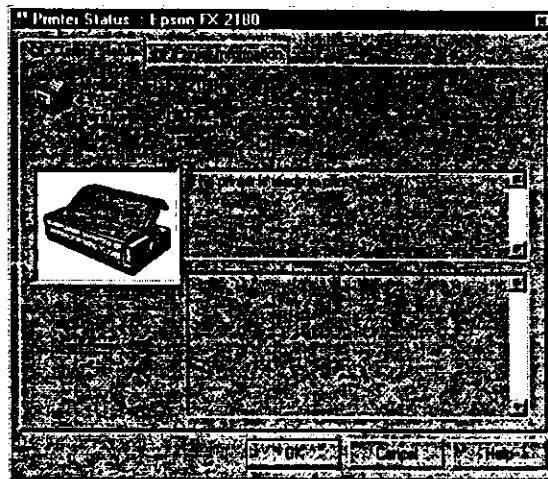

Printer.tif

The Printer Status window contains two menus: Current Status and Printer Information. To open the menus, click the tabs at the top of the Printer Status window.

Current Status menu

The printer illustration and message boxes on this menu give you detailed printer status information. The appearance of the printer illustration changes to reflect the current printer status, described in the upper message box. If a printer error occurs, the lower message box displays troubleshooting tips.

Printer Information menu

If your printer is connected to your computer through a network, this menu provides information on network connections and other printer resources.

Making Monitoring Preference Settings

The Monitoring Preferences dialog box allows you to turn on the background monitoring feature and specify the monitoring interval (the length of time between status information updates) for the selected printer. To open the Monitoring Preferences dialog box, see "Turning on background monitoring" on the next page.

When you turn on background monitoring, the Status Monitor updates the status information for the selected printer "in the background" whenever you are using your computer. A Status Alert dialog box is displayed in the lower right corner of your computer screen. It provides short messages, and a Details button that allows you to open the Printer Status window.

Turning on background monitoring

Follow the steps below to monitor the selected printer and specify when the Status Alert dialog box appears.

1. Make sure the Status Monitor is active. (It is active if a printer-shaped icon appears on the taskbar at the bottom of your computer screen.) If the icon is not on the taskbar, access EPSON Status Monitor 2 from the Start menu as described on page 6-4. Then point to Background Monitoring on the Settings menu and click Monitor from restart or Monitor now.
2. Select the printer you want to monitor from the Installed Printers list, and then click Monitoring Preferences on the Settings menu. The dialog box below appears.

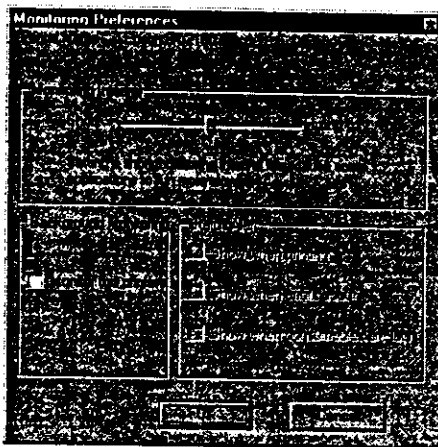

6

Prefer.tif

Note:

The Background Monitoring and Status Alert settings in the Monitoring Preferences dialog box are not available while the Status Monitor is inactive.

3. Use the slider to adjust the monitoring interval, if necessary.

Note:

Setting a short monitoring interval may cause some applications to run more slowly.

4. Click Monitor this printer to turn on background monitoring for the selected printer and view the Status Alert options.
5. Click the Status Alert options to specify when you want the Status Alert dialog box to appear.
6. Click OK to save your settings and close the Monitoring Preferences dialog box.

Using the background monitoring icon

A printer-shaped background monitoring icon appears on the taskbar on your computer screen when the Status Monitor is active. (To activate the Status Monitor, follow step 1 on page 6-11.)

Double-clicking the background monitoring icon opens the EPSON Status Monitor 2 window. Right-clicking this icon opens a pop-up menu where you can choose whether the Status Alert dialog box will appear in front of other windows on the desktop. This pop-up menu also allows you to deactivate the Status Monitor. When you deactivate the Status Monitor, the background monitoring icon disappears from the taskbar.

Chapter 7

Troubleshooting

Using the Error Indicators	7-2
Problems and Solutions	7-4
Power supply problems.....	7-5
Single-sheet paper loading or feeding problems.....	7-6
Continuous paper loading or feeding problems	7-8
Wrong top-of-form position	7-9
Wrong tear-off position.....	7-10
Printing or printout quality problems.....	7-11
Clearing Paper Jams	7-16
Aligning Vertical Lines in Your Printout.....	7-17
Printing a Self Test.....	7-18
Printing a Hex Dump	7-19

Using the Error Indicators

You can identify many common printer problems using the lights on the control panel. If your printer stops working and one or more control panel lights are on or flashing or the printer beeps, use the following table to diagnose and fix the problem. If you can't fix your printer problem using this table, go to the next section.

State of panel lights	Beep pattern	Problem
		Solution
<input type="checkbox"/> Pause	-	The printer is paused. Press the Pause button to resume printing.
	• • •	The printer cover is open. Close the printer cover and press the Pause button to resume printing.
	• • • • •	Paper from another paper source is currently in the paper path. Move the paper release lever back to the appropriate position and press the Load/Eject button to feed the paper out of the paper path. Then set the lever to the position you want to use. Press the Pause button to turn off the Pause light, if necessary.
<input type="checkbox"/> Paper Out <input type="checkbox"/> Pause	• • •	No paper is loaded in the selected paper source. Load paper in the printer. Then press the Pause button to turn off the Pause light, if necessary.
	• • •	The paper is not loaded correctly. Remove your paper and reload it correctly. See Chapter 2 (continuous paper) or Chapter 3 (single sheets) for instructions on loading paper. Then press the Pause button to turn off the Pause light, if necessary.
	• • •	Paper is jammed in the printer. Clear the paper jam as described on page 7-16.

State of panel lights	Beep pattern	Problem
		Solution
<input type="checkbox"/> Paper Out <input type="checkbox"/> Pause	• • •	Continuous paper is not fed to the standby position. Tear off the printed document at the perforation; then press the Load/Eject button. The printer feeds the paper to the standby position. Press the Pause button to turn off the Pause light.
		A single sheet of paper is not fully ejected. Press the Load/Eject button to eject the sheet. Then press the Pause button to turn off the Pause light, if necessary.
		Paper is jammed in the printer. Clear the paper jam as described on page 7-16.
<input type="checkbox"/> Pause	-	The print head is overheated. Wait a few minutes; the printer resumes printing automatically once the print head cools.
<input type="checkbox"/> Paper Out <input type="checkbox"/> Pause <input type="checkbox"/> Tear Off/Bin <input type="checkbox"/> Font	-	An unknown printer error has occurred. Turn off the printer and leave it off for several minutes; then turn on the printer again. If the error recurs, contact your dealer.



= on, = flashing
 • • • = short series of beeps (three beeps), • • • • • = long series of beeps (five beeps)

Note:
 The printer beeps once if you press a control panel button when the corresponding function is not available.

Problems and Solutions

Most printer problems are easy to solve. Use the information in this section to find the source of and solution to any printer problems that occur.

Determine the type of problem that occurred, and see the appropriate page below:

Power supply problems 7-5

Single-sheet paper loading or
feeding problems 7-6

Continuous paper loading or
feeding problems 7-8

Wrong top-of-form position 7-9

Wrong tear-off position 7-10

Printing or printout quality problems. . 7-11

You can also use the self test to determine whether the printer or the computer is causing the problem. See page 7-18 for instructions on printing a self test.

To pinpoint communication problems, experienced users may want to use the printer's hex dump mode, described on page 7-19.

To clear a paper jam, see page 7-16.

Power supply problems

The control panel lights come on briefly, but then go off and stay off.

Cause	What to do
The printer's voltage rating does not match the voltage of your electrical outlet.	Check the printer and the outlet voltage ratings. If the voltages do not match, unplug the printer immediately and contact your dealer.



Warning:

Do not reconnect the power cord to an electrical outlet that has the wrong voltage for your printer.

The printer does not work and the control panel lights are off even though you turned on the printer.

Cause	What to do
The power cord is not properly plugged into the electrical outlet or your printer.	Press the Operate button to turn off the printer, and make sure the power cord is firmly plugged into the electrical outlet and the printer, if necessary. Then press the Operate button to turn on the printer.
The electrical outlet does not work.	Use a different outlet.



Single-sheet paper loading or feeding problems

The printer does not load single-sheet paper or does not feed it properly.

Cause	What to do
The paper release lever is set to a tractor position.	Set the paper release lever to the single-sheet position. For more information on setting the paper release lever, see Chapter 2.
Continuous paper is in the paper path.	Set the paper release lever to the appropriate tractor position and press the Load/Eject button to feed the continuous paper to the standby position. Then set the paper release lever to the single-sheet position. (See Chapter 2 for more information on switching to printing on single sheets.)
The paper on the paper guide is positioned too far to the right for the printer to detect that it is there.	Move the paper a little to the left.
Single-sheet paper is not loaded properly.	See Chapter 3 for instructions on loading single-sheet paper.
The paper thickness lever is not set correctly.	Set the paper thickness lever to match the thickness of your paper. See "Setting the Paper Thickness Lever" in Chapter 2.
Your paper is creased, old, too thin, or too thick.	See the paper specifications in Appendix C and use new, clean sheets of paper.

The printer does not fully eject a single sheet.

Cause	What to do
Your paper is too long.	Press the Load/Eject button to eject the sheet. Make sure the page length of your paper is within the range specified for single-sheet paper in Appendix C. Also check and adjust the paper size setting in your application or printer driver.

The optional cut-sheet feeder does not feed your single-sheet paper properly.

Cause	What to do
The cut-sheet feeder is not installed properly.	Reinstall it as described in Appendix A.
Too many sheets are loaded in the cut-sheet feeder.	Load no more than 150 single sheets in the high-capacity cut-sheet feeder. See "Using the Optional Cut-Sheet Feeders" in Appendix A for more information.
The edge guides of the cut-sheet feeder are not positioned correctly.	Align the left edge guide with the arrow mark, then move the right edge guide to match your paper's width.
There is only one sheet left in the bin.	Load more paper in the cut-sheet feeder.

Continuous paper loading or feeding problems**The printer does not load continuous paper or does not feed it properly.**

Cause	What to do
The paper release lever is not set correctly.	Set the paper release lever to the tractor position for the paper source you want to use. For more information on setting the paper release lever, see Chapter 2.
Single-sheet paper is in the paper path.	Set the paper release lever to the single-sheet position and press the Load/Eject button to eject the sheet. Then set the paper release lever back to the appropriate tractor position. (See Chapter 2 for more information on switching to printing on continuous paper.)
Continuous paper is not loaded properly.	See Chapter 2 for instructions on loading continuous paper on the tractor you want to use.
The paper thickness lever is not set correctly.	Set the paper thickness lever to match the thickness of your paper. See "Setting the Paper Thickness Lever" in Chapter 2.

The printer does not feed continuous paper to the standby position.

Cause	What to do
You did not tear off the printed pages before pressing the Load/Eject button.	Tear off the printed pages at the perforation. Then press the Load/Eject button to feed the paper backward to the standby position.

Wrong top-of-form position

Printing starts too high or low on the page.

Cause	What to do
The paper size setting in your application software or printer driver does not match the size of the paper you are using.	Check the paper size setting in your application or printer driver.
The printer's page length settings for the front or rear tractor do not match the size of the continuous paper you are using.	Check the page length settings for the front or rear tractor using the printer's default-setting mode or the EPSON Remote! utility. See "About Your Printer's Default Settings" in Chapter 5, or "Using the EPSON Remote! Utility" in Chapter 4.
The top margin or top-of-form position setting is incorrect.	Check the margin or top-of-form position setting in your application software. See the printable area specifications in Appendix C. Adjust the top-of-form position in micro adjust mode. However, settings made in Windows applications override settings made in micro adjust mode. See "Adjusting the Top-of-Form Position" in Chapter 2.
The printer you want to use is not selected in your software.	Choose the correct printer from the Windows desktop or in your application before printing.
You moved the paper using the knob while the printer was on.	Adjust the top-of-form position using the micro adjust feature. See "Adjusting the Top-of-Form Position" in Chapter 2.



Caution:

Never use the knob to adjust the top-of-form position; this may damage the printer or cause it to lose the top-of-form position.

Wrong tear-off position

The printer prints on (or too far away from) the perforation of your continuous paper.

Cause	What to do
The tear-off position setting is incorrect.	Adjust the tear-off position using the micro adjust feature. See "Adjusting the tear-off position" in Chapter 2.
You moved the paper using the knob while the printer was on.	Adjust the tear-off position using the micro adjust feature. See "Adjusting the tear-off position" in Chapter 2.
 Caution: <i>Never use the knob to adjust the tear-off position; this may damage the printer or cause it to lose the tear-off position.</i>	
The printer you want to use is not selected in your software.	Choose the correct printer from the Windows desktop or in your application before printing.
The paper size setting in your application or printer driver does not match the size of the paper you are using.	Check the paper size setting in your application or printer driver.
The printer's page length settings for the front or rear tractor do not match the size of the continuous paper you are using.	Check the page length settings for the front or rear tractor using the printer's default-setting mode or the EPSON Remote! utility. See "About Your Printer's Default Settings" in Chapter 5, or "Using the EPSON Remote! Utility" in Chapter 4.

Printing or printout quality problems

The printer does not print when the computer sends data.	
---	--

Cause	What to do
The printer is paused.	Press the PAUSE button.
The printer cover is open.	Close the printer cover and press the PAUSE button to resume printing.
The interface cable is not plugged in securely.	Check that both ends of the cable between the printer and the computer are plugged in securely. If the cable is connected correctly, run a self test as described later in this chapter.
Your interface cable does not meet the printer and/or computer specifications.	Use an interface cable that meets the requirements of both the printer and computer. See page A-3 and your computer documentation.
Your software is not properly set up for your printer.	Select your printer from the Windows desktop or in your application. If necessary, install or reinstall the printer driver software as described in Chapter 1.

The printer makes noise, but nothing prints or printing stops abruptly

Cause	What to do
The paper thickness lever is set incorrectly.	Set the paper thickness lever to match the thickness of your paper. See "Setting the Paper Thickness Lever" in Chapter 2.
The ribbon has too much slack, the ribbon has come loose, or the ribbon cartridge is not installed properly.	Remove any slack in the ribbon by turning the ribbon-tightening knob, or reinstall the ribbon cartridge as described in Chapter 1.

The printout is faint.

Cause	What to do
The paper thickness lever is set incorrectly for your paper.	Move the paper thickness lever to a lower setting.
The ribbon is worn out.	Replace the ribbon cartridge as described in Chapter 1.

The printout has gaps.

Cause	What to do
The paper thickness lever is not set correctly.	Set the paper thickness lever to match the thickness of your paper. See page 2-4 for continuous paper, or page 3-3 for single sheets.

Part of the printout is missing, or dots are missing in random positions.

Cause	What to do
The ribbon has too much slack, the ribbon has come loose, or the ribbon cartridge is not installed properly.	Remove any slack in the ribbon by turning the ribbon-tightening knob, or reinstall the ribbon cartridge as described in Chapter 1.
The ribbon is worn out.	Replace the ribbon cartridge as described in Chapter 1.

Lines of dots are missing in the printout.

Cause	What to do
The print head is damaged.	Stop printing and contact your dealer to have the print head replaced.



Caution:

Never replace the print head yourself; you may damage the printer. Also, other parts of the printer must be checked when the print head is replaced.

7

All the text is printed on the same line.

Cause	What to do
No line feed command is sent at the end of each line of text.	Turn on the auto line feed setting using the printer's default-setting mode or the EPSON Remote! utility so that the printer automatically adds a line feed code to each carriage return. See "About Your Printer's Default Settings" in Chapter 5 or "Using the EPSON Remote! Utility" in Chapter 4.

The printout has extra blank lines between lines of text.

Cause	What to do
Two line feed commands are being sent at the end of each line of text.	Turn off the auto line feed setting using the printer's default-setting mode or the EPSON Remote! utility. See "About Your Printer's Default Settings" in Chapter 5, or "Using the EPSON Remote! Utility" in Chapter 4.
The line space setting in your application software is incorrect.	Adjust the line space setting in your application software.
The skip-over-perforation setting is on.	Turn off the skip-over-perforation setting in the default-setting mode or the EPSON Remote! utility. See "About Your Printer's Default Settings" in Chapter 5, or "Using the EPSON Remote! Utility" in Chapter 4.

The printer prints strange symbols, incorrect fonts, or other inappropriate characters.

Cause	What to do
Your printer and computer are not communicating correctly.	Make sure that you are using the correct interface cable and that the communications protocol is correct. See page A-3 and your computer documentation. If you installed an optional serial interface card, also see page A-18.

The wrong character table is selected in your software. Select the correct character table using your software, the default-setting mode, or the EPSON Remote! utility. The character table setting in your software overrides settings made in the default-setting mode or EPSON Remote!.

The printer you want to use is not selected in your software. Choose the correct printer from the Windows desktop or in your application before printing.

Your application software is not configured correctly for your printer. Make sure that your application software is set up correctly for your printer. See your application documentation. If necessary, install or reinstall the printer driver software as described in Chapter 1.

Software settings override settings you make using the default-setting mode, EPSON Remote!, or the control panel buttons. Use your application software to select the font.

Vertical printed lines are not aligned.

Cause	What to do
Bidirectional printing, which is the printer's standard printing mode, is out of alignment.	Use the printer's bidirectional adjustment mode to correct this problem. See "Aligning Vertical Lines in Your Printout" later in this chapter.

Clearing Paper Jams

To clear a paper jam, follow these steps:

1. Press the Operate button to turn off the printer.
2. If a single-sheet of paper is stuck on the paper guide, gently remove it.
3. Remove the printer cover. If you are loading continuous paper from the rear slot, remove the paper guide.
4. If continuous paper is jammed in the printer, tear off the fresh supply at the perforation nearest the paper entry slot.
5. Turn the knob on the right side of the printer away from you to eject the paper in the printer. Remove any remaining pieces of paper.



Caution:

Use the knob on the right side of the printer only to clear paper jams when the printer is off. Otherwise, you may damage the printer or lose the top-of-form or tear-off position.

6. Replace the paper guide if necessary, and replace the printer cover. Then close the paper guide cover.
7. Press the Operate button to turn on the printer. Make sure the Paper Out and Pause lights are off.

Aligning Vertical Lines in Your Printout

If you notice that the vertical lines in your printout are not properly aligned, you can use the printer's bidirectional adjustment mode to correct this problem.

Note:

- *To complete the steps below, you need four sheets of A3-size single-sheet paper or four pages of continuous paper that are at least 279 mm (11 inches) long and 376 mm (14.8 inches) wide. See Chapter 2 for instructions on loading continuous paper, or Chapter 3 for instructions on loading single sheets.*
- *If you use single sheets, you need to load a new sheet of paper each time the printer ejects a printed sheet onto the paper guide.*

Follow these steps to perform the bidirectional adjustment:

1. Make sure paper is loaded and the printer is turned off.



Caution:

Whenever you turn off the printer, wait at least five seconds before turning it back on; otherwise you may damage the printer.



2. While holding down the Pause button, press the Operate button to turn on the printer. The printer enters the bidirectional adjustment mode and then prints instructions and the first set of alignment patterns.
3. As described in the instructions, compare the alignment patterns and select the pattern with the best alignment.
4. Follow the instructions to print the remaining sets of alignment patterns and select the pattern with the best alignment in each set.

5. After you select the best pattern in the final set of alignment patterns, press the **Operate** button to turn off the printer and exit the bidirectional adjustment mode. Your selections are saved automatically.

Printing a Self Test

Running the printer's self test helps you determine whether the printer or the computer is causing the problem:

- If the self test results are satisfactory, the printer is working properly and the problem probably results from your printer driver settings, application settings, computer, or interface cable. (Be sure to use a shielded interface cable.)
- If the self test does not print properly, there is a problem with the printer. See "Problems and Solutions" for possible causes and solutions to the problem.

You can print the self test using either single sheets or continuous paper. See Chapter 2 for instructions on loading continuous paper, or Chapter 3 for instructions on loading single sheets.

Note:

Use paper that is at least 376 mm (14.8 inches) wide, such as A3-size paper.

To perform a self test, follow these steps:

1. Make sure paper is loaded and the printer is turned off.



Caution:

Whenever you turn off the printer, wait at least five seconds before turning it back on; otherwise you may damage the printer.

2. To run the test using the Draft font, hold down the LF/FF button while you press the Operate button to turn on the printer. To run the test using the printer's letter-quality fonts, hold down the Load/Eject button while you turn on the printer. Either self test can help you determine the source of your printing problem; however, the draft test prints faster than the letter-quality test.

After a few seconds, the printer loads the paper automatically and begins printing the self test. A series of characters is printed.

Note:

To temporarily stop the self test, press the PAUSE button. To resume the test, press the PAUSE button again.

3. To end the self test, press the Pause button to stop printing and the Load/Eject button to eject the printed page. Then turn off the printer.

Printing a Hex Dump

If you are an experienced user or a programmer, you can print a hexadecimal dump to isolate communication problems between the printer and your software program. In hex dump mode, the printer prints all data received from the computer as hexadecimal values.

You can print a hex dump using either single sheets or continuous paper. See Chapter 2 for instructions on loading continuous paper, or Chapter 3 for instructions on loading single sheets.

Note:

Use paper that is at least 210 mm (8.3 inches) wide, such as A4- or letter-size paper.

To print a hex dump, follow the steps below.

1. Make sure paper is loaded and the printer is turned off.

**Caution:**

Whenever you turn off the printer, wait at least five seconds before turning it back on; otherwise you may damage the printer.

2. To enter hex dump mode, hold down both the LF/FF and Load/Eject buttons while you press the Operate button to turn on the printer.
3. Open a software program and send a print job to the printer. Your printer prints all the codes it receives in hexadecimal format.

dump.tif

If characters are printable, they appear in the right column as ASCII characters. Nonprintable codes, such as control codes, are represented by dots. By comparing the characters printed in the right column with the printout of the hexadecimal codes, you can check the codes the printer is receiving.

4. To exit hex dump mode, press the Pause button to stop printing and the Load/Eject button to eject the printed page(s). Then turn off the printer.

Proof Sign-off:
<antoname> _____
<leadername> _____
<editorname> _____

Sun-E+
Pre Rev. C

A5 size
8/5/98

Appa.fm
Pass 0

R

Appendix A

Enhancing Your Printer With Options

Options	A-2
Paper handling options	A-2
Optional interface cards	A-3
Using the Optional Cut-Sheet Feeders	A-4
Installing the high-capacity or double-bin cut-sheet feeder	A-4
Loading paper in the high-capacity cut-sheet feeder	A-6
Selecting the paper source (bin 1 or bin 2)	A-10
Switching between continuous paper and single-sheet paper in the cut-sheet feeder	A-11
Using the Roll Paper Holder	A-12
Assembling the roll paper holder	A-12
Installing the roll paper holder	A-13
Loading roll paper	A-14
Removing roll paper	A-16
Installing an Interface Card	A-17
Using the C82305* or C82306* serial interface card	A-18

A

Options

As described below, a variety of paper handling options and interface cards are available for your printer. To purchase options, contact your dealer or customer support as described in Appendix D.

Paper handling options

High-capacity cut-sheet feeder (C80673*)

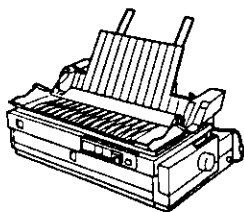

Feeds up to 150 sheets of paper, 25 plain bond envelopes, or 30 postcards into the printer without reloading. You can also load a stack of single-sheet multi-part forms up to 15 mm (0.59 inch) thick in this feeder. For instructions on using this option, see page A-4.

4-4.eps

Second bin cut-sheet feeder (C80674*)

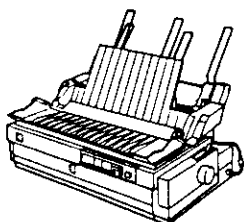

Connects to the high-capacity cut-sheet feeder to create a double-bin cut-sheet feeder. You can load up to 50 sheets of ordinary single-sheet paper in the second-bin cut-sheet feeder. For instructions on using this option, see page A-4.

4-4-2.eps

Pull tractor (C80032*)

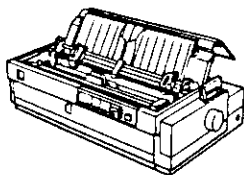

Improves continuous paper handling and reduces the chance of paper jams. Using a pull tractor in combination with a push tractor is especially useful for printing on continuous pre-printed forms, multi-part forms, and labels, and for printing high-quality graphics. For instructions on using this option, see page 2-21.

A-2-3.eps

Proof Sign-off:
<stantname>
<leadename>
<editname>

Sun-E+ Pre Rev. C

A5 size
8/5/98

Appa.fm
Pass 0

R

Roll paper holder (#8310)

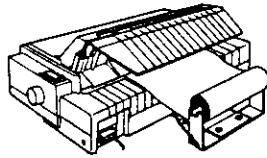

Allows you to use your printer with 8.5-inch roll paper like that used with telex machines. For instructions on using this option, see page A-12.

New09.eps

Note:

The asterisk (*) is a substitute for the last digit of the product number, which varies by country.

Optional interface cards

You can install an optional interface card to supplement your printer's built-in parallel interface and provide added network compatibility. The EPSON interface cards in the table below are compatible with your printer. (Not all interfaces are available in all countries.)

For instructions on installing an interface card, see page A-17.

Model number	Name
C82305* / C82306*	Serial interface card
C82307* / C82308*	32KB serial interface card
C82310* / C82311*	32KB parallel interface card
C82312*	LocalTalk interface card
C82313*	32KB IEEE-488 interface card
C82314*	Coax interface card
C82315*	Twinax interface card
C82345*	IEEE-1284 parallel interface card
C82357* / C82362* / C82364*	Ethernet interface card

The asterisk (*) is a substitute for the last digit, which varies by country.

If you are unsure whether you need an optional interface or would like to know more about interfaces, contact your dealer.

A

L

Sun-E+
Pre Rev. C

A5 size
8/5/98

Appa.fm
Pass 0

Proof Sign-off:

<stantname> _____

<leadername> _____

<editorname> _____

Using the Optional Cut-Sheet Feeders

When you install the optional high-capacity cut-sheet feeder (C80673*), you can load up to 150 single sheets of paper in the printer. Also you can create a double-bin cut-sheet feeder by connecting the second bin cut-sheet feeder (C80674*) to the high-capacity cut-sheet feeder. The double-bin cut-sheet feeder allows you to load two different types of single-sheet paper in the printer at the same time and easily switch between them. To assemble the double-bin cut-sheet feeder and load paper in the second-bin cut-sheet feeder, see the second-bin cut-sheet feeder manual. For instructions on selecting bin 1 or bin 2 of the double-bin cut-sheet feeder, see page A-10.

Note:

The second-bin cut-sheet feeder can be used only in combination with the high-capacity cut-sheet feeder; you cannot use it alone.

Installing the high-capacity or double-bin cut-sheet feeder

You install the high-capacity cut-sheet feeder and double-bin cut-sheet feeder in the same way. Follow the steps below.

Note:

Before installing the double-bin cut-sheet feeder, assemble it as described in the cut-sheet feeder manual.



Warning:

You will need to move the print head by hand before installing the cut-sheet feeder. If you have just used the printer, the print head may be hot; let it cool for a few minutes before touching it.

1. Make sure the printer is turned off.



Caution:

Be sure to turn off the printer. You will need to move the print head to the ribbon installation position before installing the high-capacity cut-sheet feeder, and moving the print head while the printer is on may damage the printer.

2. Remove the paper guide and printer cover. Then press up the tabs on both sides of the paper tension unit and lift it up and off the printer. If a tractor is installed in the pull position, remove it as described on page 2-32. Store unused parts in a safe place.
3. Hold the cut-sheet feeder in both hands and fit the feeder's notches over the mounting posts on the printer as shown below. Then release the latch levers and lower the cut-sheet feeder until it rests on the printer.

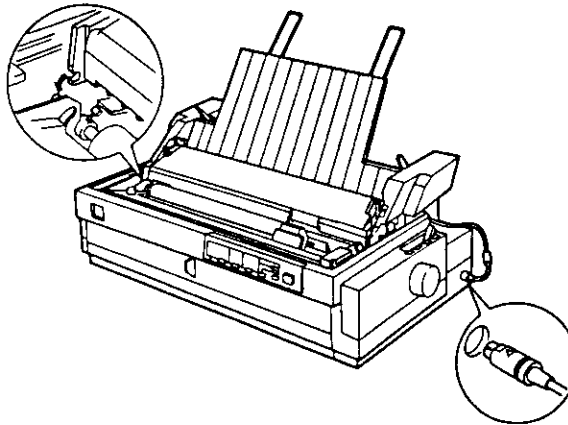

4-1.eps



4. Insert the cable into the connector as shown above.
5. Replace the printer cover.

You are now ready to load paper in the cut-sheet feeder. To load paper in the high-capacity cut-sheet feeder, see the next section. To load paper in the second bin of the double-bin cut-sheet feeder, see the manual that comes with the second-bin cut-sheet feeder. If you installed the double-bin cut-sheet feeder, you need to select the paper source (bin 1 or bin 2) as described on page A-10.

To remove the cut-sheet feeder, reverse the steps above.

L

Sun-E+
Pre Rev. C

A5 size
8/5/98

Appa.fm
Pass 0

Proof Sign-off:
<antoname>
<leadname>
<editname>

Loading paper in the high-capacity cut-sheet feeder

You can load up to 150 ordinary single sheets, 25 plain bond envelopes, or 30 postcards in the high-capacity cut-sheet feeder. You can also load a stack of single-sheet multi-part forms up to 15 mm (0.59 inch) thick in this feeder.

Follow the steps below to load paper in the high-capacity cut-sheet feeder.



Caution:

Do not load carbon paper or labels in the high-capacity cut-sheet feeder.

1. Open the paper guide cover, and set the paper release lever to the single-sheet position. Also make sure the paper thickness lever (located under the printer cover) is set to the proper position for your paper's thickness.

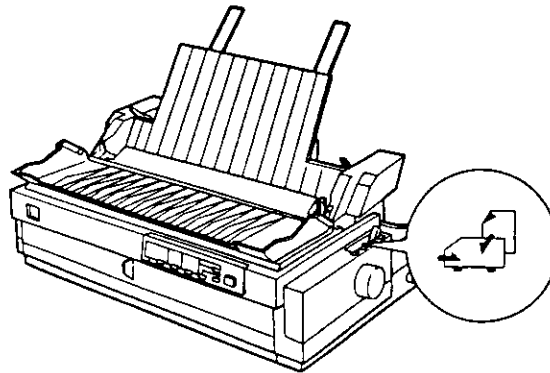

4-4a.eps

2. Pull down the center support.

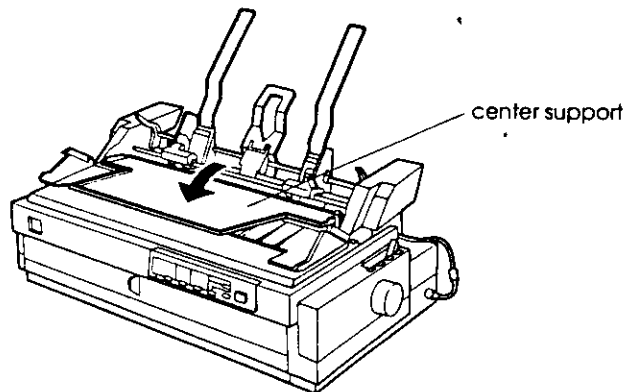

4-2-1.eps

Proof Sign-off:
<tantaname>
<leadername>
<editorname>



Sun-E+ Pre Rev. C

A5 size
8/5/98

Appa.fm
Pass 0

R

3. Release the left and right paper guides of the cut-sheet feeder by pulling the lock levers forward.

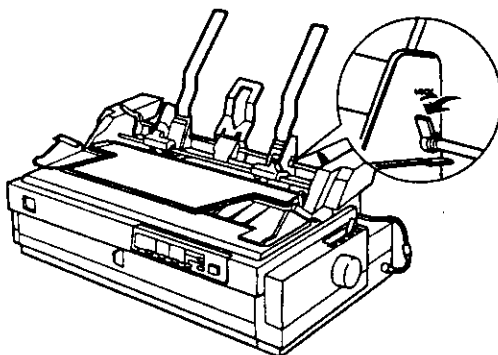

4-2-2a.eps

4. Holding the lower portion of the left paper guide, slide it until it is aligned with the arrow mark on the back of the center support. Then push the left lock lever backward to lock it in place. Holding the lower portion of the right paper guide, slide it to match the width of your paper, but do not lock it.

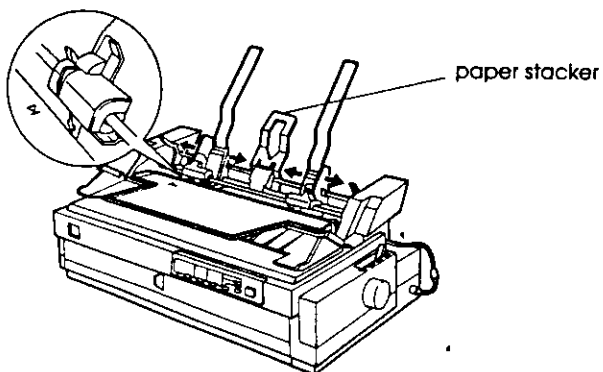

4-2-3.eps

5. Slide the paper stacker midway between the paper guides as shown above.

6. As shown below, set the cut-sheet feeder's paper type levers to the proper position for the paper you will load: single-sheet paper or postcards and envelopes.

Note:

Always set the paper type levers before you load paper.

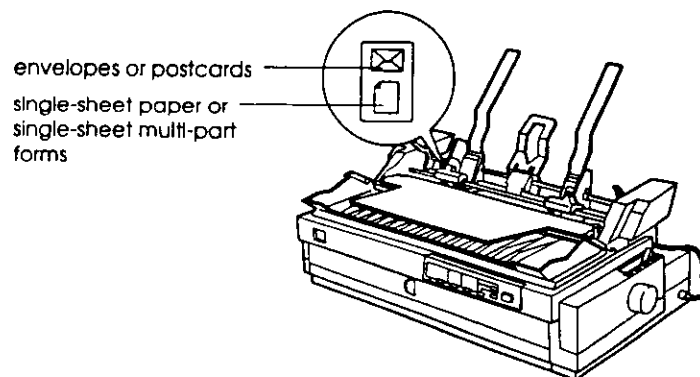

7. Pull both paper set levers forward until the paper guides retract and lock open to allow paper loading.

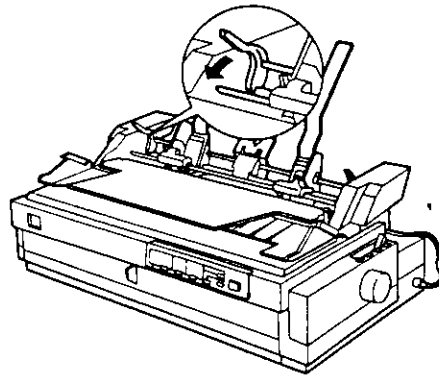

8. Take a stack of paper (up to 150 sheets of plain paper) and fan it. Next, tap the side and bottom edges of the paper on a flat surface to even up the stack.
9. Insert the paper stack printable side down along the left paper guide.

Proof Sign-off:
<antoname>
<leadename>
<editorname>

Sun-E+ Pre Rev. C

A5 size
8/5/98

Appa.fm
Pass 0

R

10. Adjust the right paper guide so that it matches your paper's width. Make sure the position of the guide allows the paper to move up and down freely. Then push the lock lever backward to lock the paper guide.
11. Push back the paper set levers to clamp the paper against the guide rollers.
12. Move the cut-sheet feeder's paper selection lever to the single-sheet position, as shown below. Then lift up the center support and close the paper guide cover.

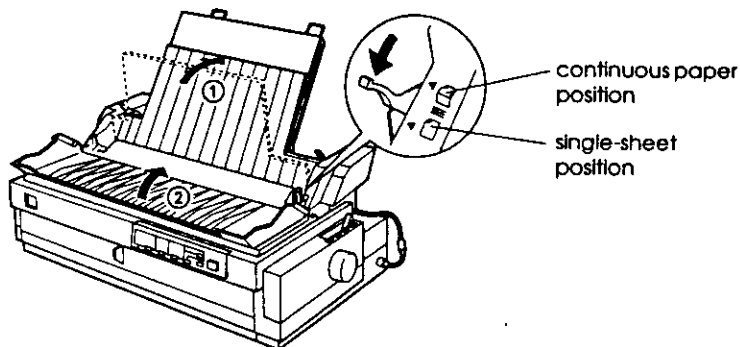

4-4b.eps

Note:

- Always close the printer cover before printing. The printer does not print when the cover is open.
- When the cut-sheet feeder is installed, you can still load single sheets one at a time using the front paper slot.

The cut-sheet feeder automatically loads paper when the printer receives data. Printed pages are stacked on the center support. If you need to eject a sheet, press the Load/Eject button.

If the first printed line on your page appears too high or low, you can adjust its position using the micro adjust feature. See "Adjusting the Top-of-Form Position" on page 2-36.



Caution:

Never use the knob to adjust the top-of-form position; this may damage the printer or cause it to lose the top-of-form position.

A

L

Sun-E+
Pre Rev. C

A5 size
8/5/98

Appa.fm
Pass 0

Proof Sign-off:
<antname>
<leadname>
<editname>

Selecting the paper source (bin 1 or bin 2)

When the double-bin cut-sheet feeder is installed, you need to select the paper source (bin 1 or bin 2) using your application or the printer's control panel. As shown below, the high-capacity cut-sheet feeder is bin 1 and the second-bin cut-sheet feeder is bin 2.

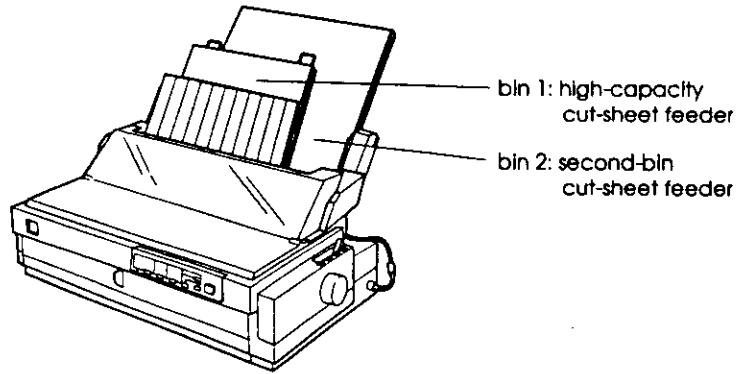

G4-17.eps

It is best to select the paper source in your application program because software settings usually override the printer's control panel settings. However, if you cannot select the paper source in your application, press the Tear Off/Bin button until the lights indicate the bin you want as shown below. When the printer receives data, it automatically loads paper from the bin you select.

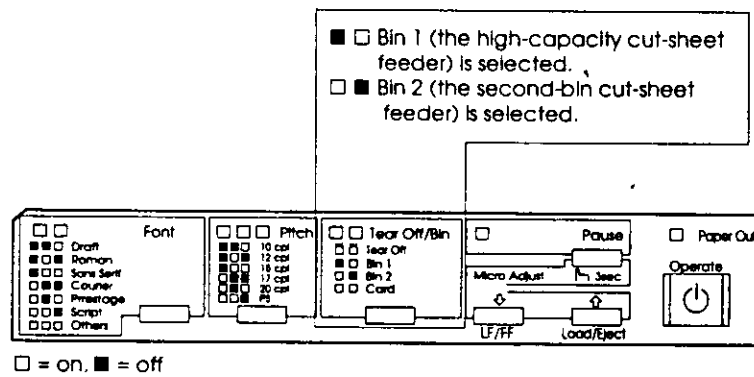

Panel.eps

Switching between continuous paper and single-sheet paper in the cut-sheet feeder

You can easily switch between continuous paper on a push tractor and single-sheet paper in the cut-sheet feeder without removing the continuous paper.

Switching to continuous paper

1. If any single sheets are in the paper path, press the Load/Eject button to eject them.
2. Move the printer's paper release lever to the front or rear push tractor position. Also set the paper thickness lever to the proper position for the thickness of your continuous paper.
3. Move the cut-sheet feeder's paper selection lever to the continuous paper position.

Switching to single-sheet paper in the cut-sheet feeder

1. If any continuous paper remains in the printer, press the Tear Off/Bin button to advance the paper to the tear-off position. Then tear off the printed pages.



Caution:

Tear off your printed document before you press the Load/Eject button in the next step. Reverse feeding several pages at a time may cause a paper jam.

2. Press the Load/Eject button. The printer feeds the continuous paper backward to the standby position. The paper is still attached to the push tractor but is no longer in the paper path.
3. Move the printer's paper release lever to the single-sheet position. Also set the paper thickness lever to the proper position for the thickness of your single-sheet paper.
4. Move the cut-sheet feeder's paper selection lever to the single-sheet position.
5. If you are using the double-bin cut-sheet feeder, select the bin you want to use as described on page A-10.





Using the Roll Paper Holder

The optional roll paper holder (#8310) allows you to use 8.5-inch roll paper like that used with telex machines. This provides an inexpensive alternative to using continuous paper for applications that require variable paper lengths. Before you install and use the roll paper holder, you need to assemble it.

Assembling the roll paper holder

1. Fit the arc bearings into the stand as shown.

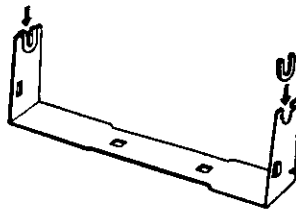

G3-30-1.eps

2. Make sure you orient the stand and base plate as shown below. Then place the base plate on the stand and fasten the two together with the plastic spacing clips.

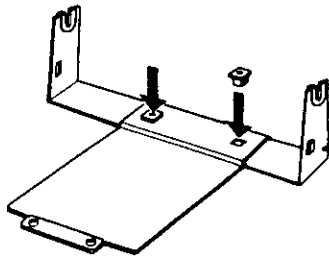

G3-30-2.eps

- Hook the tension lever onto both ends of the stand as shown below. While pulling up the tension lever, fit the wire ends of the tension lever into the holes in the stand. The roll paper holder is assembled.

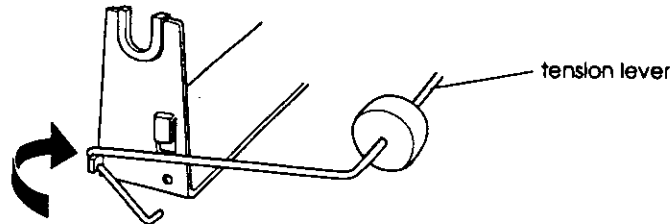

G3-30-3.eps

Installing the roll paper holder

- Make sure the printer is turned off.
- Position the roll paper holder underneath the printer as shown below. Fit the two positioning pegs on the bottom of the printer into the two holes in the base plate.

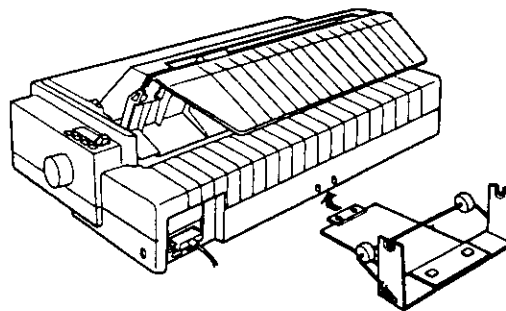

A

4-6.eps



Caution:

The roll paper holder is not fastened to the printer; only the printer's weight and the two positioning pegs hold it in place. If you pick up the printer, be careful not to drop the roll paper holder.

To remove the roll paper holder, carefully lift up the printer and pull out the roll paper holder from beneath the printer.

Loading roll paper

After you install the roll paper holder, follow the steps below to load a roll of paper:

1. Make sure the printer is turned off. Then open the paper guide cover and remove the paper guide.
2. Make sure the paper tension unit is installed.
3. Set the paper thickness lever (located under the printer cover) to the proper position for the thickness of your roll paper.
4. Set the paper release lever to the single-sheet position.
5. Cut the leading edge of the roll paper straight across.

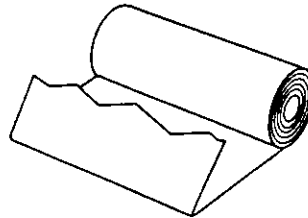

G3-31-2.eps

6. Insert the roll paper holder shaft into the center of the paper roll as shown.

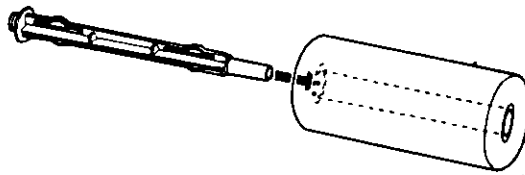

G3-32-1.eps

Proof Sign-off:
<stantname>
<leademame>
<editomame>



Sun-E+ Pre Rev. C

A5 size
8/5/98

Appa.fm
Pass 0

R

7. Place the shaft and paper roll on the roll paper holder so the paper feeds from the bottom of the roll.

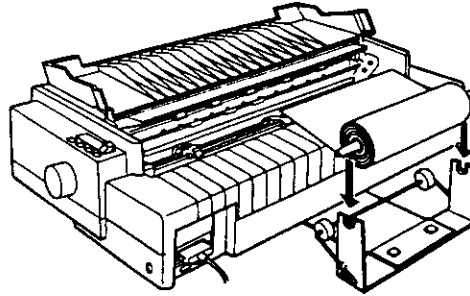

G3-32-2.eps

8. Turn on the printer. Then bring the leading edge of the paper up over the rear push tractor and insert it until it meets resistance. The printer loads the roll paper automatically.
9. Replace the paper guide and close the paper guide cover. You are now ready to print. The printed roll paper is fed over the paper guide to the back of the printer, as shown below.

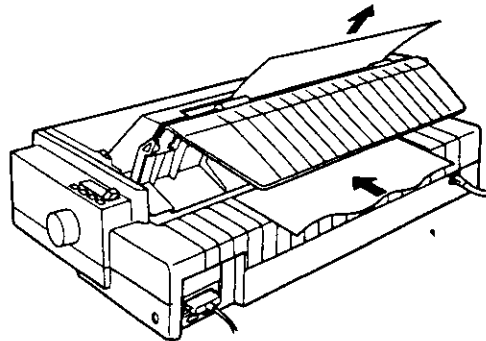

A

4-9.eps

L

Sun-E+
Pre Rev. C

A5 size
8/5/98

Appa.fm
Pass 0

Proof Sign-off:
<antname> _____
<leadname> _____
<editname> _____

When you finish printing, open the paper guide cover and press the LF/FF button to advance the paper. Then tear off the paper using the tear-off edge of the printer (pull it towards you for a clean cut).

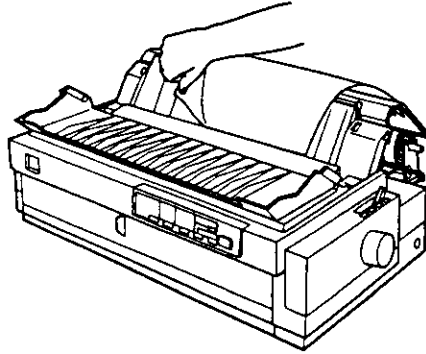

G3-43.eps

Removing roll paper

Roll paper cannot be fed backward. To remove roll paper, open the paper guide cover and remove the paper guide; then cut the paper behind where it feeds into the printer. Press the Load/Eject button to eject the remaining paper.

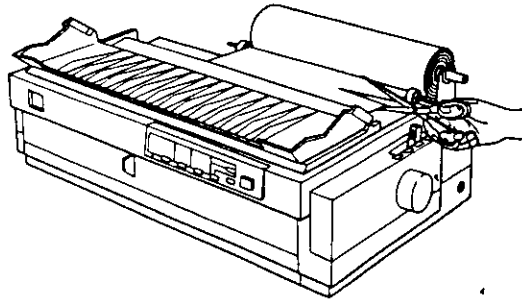

New08.eps

Proof Sign-off:
<stantname>
<leadename>
<editname>



Sun-E+ Pre Rev. C

A5 size
8/5/98

Appa.fm
Pass 0

R

Installing an Interface Card

Follow the steps below to install an optional interface card.

1. Make sure the printer is turned off. Unplug the printer's power cord and disconnect the interface cable.
2. Remove the screws from the shield plate on the back of the printer and remove the plate.

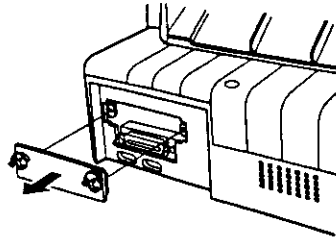

4-10.eps

3. Slide the interface card along the slots on both sides of the interface compartment. Firmly push in the card to make sure the connector at the back of the interface card is fully inserted into the printer's internal socket. Then replace the screws and tighten them.

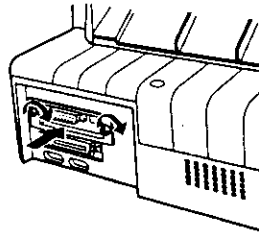

4-11.eps

Note:

Store the shield plate in a safe place; you will need to reattach it if you remove the interface card later.

To remove the interface card, reverse the steps above.

L

Sun-E+
Pre Rev. C

A5 size
8/5/98

Appa.fm
Pass 0

Proof Sign-off:
<antoname>
<leadername>
<editorname>

Using the C82305* or C82306* serial interface card

To use the C82305* or C82306* serial interface card, see the sections below regarding the baud rate, handshake timing, and error handling. For all other data transfer conventions, such as word structure and communications protocol, see your interface card manual.

Selecting a baud rate

You can select from the following baud rates: 300, 600, 1200, 2400, 4800, 9600, and 19200 bps (bits per second). To set the baud rate, see the bit-rate selection table in your interface card manual.

Handshake timing

When the unused area for data in the input buffer drops to 256 bytes, the printer outputs an X-OFF code or sets the DTR flag to 1 (MARK) to indicate that it cannot receive data. When the unused area increases to 512 bytes, the printer outputs an X-ON code or sets the DTR flag to 0 (SPACE) to indicate that it is ready to receive data.

Error handling

When the printer detects a parity error, the print data is replaced with an asterisk (*). The printer ignores all other errors, including framing and overrun errors.

Proof Sign-off:
<antname> _____
<leadname> _____
<editname> _____

Sun-E+
Pre Rev. C

A5 size
8/5/98

Appb.fm
Pass 0

R

Appendix B

Cleaning and Transporting the Printer

Cleaning the Printer B-2
Transporting the Printer B-3

B

L

Sun-E+
Pre Rev. C

A5 size
8/5/98

Appb.fm
Pass 0

Proof Sign-off:
<antname> _____
<leadname> _____
<editname> _____

Cleaning the Printer

To keep your printer operating at its best, you should clean it thoroughly several times a year. Follow these steps:

1. Make sure the printer is turned off. Then remove any paper loaded in the printer.
2. Remove the paper guide. If a pull tractor or an optional cut-sheet feeder is installed, remove it.
3. Use a soft brush to carefully brush away all dust and dirt from the outer case and paper guide.
4. If the outer case or paper guide is still dirty, clean it with a soft, clean cloth dampened with mild detergent dissolved in water. Keep the printer cover in place and lower the paper guide cover until it lies flat on the top of the printer to prevent water from getting inside the printer.



Caution:

- Never use alcohols or thinners to clean the printer; these chemicals can damage the printer components as well as the case.
- Be careful not to get water on the printer mechanism or electronic components.
- Do not use a hard or abrasive brush.
- Do not spray the inside of the printer with lubricants; unsuitable lubricants can damage the printer mechanism. Contact an EPSON dealer if you think lubrication is needed.

Proof Sign-off:
<antoname>
<leadername>
<editorname>

Sun-E+ Pre Rev. C

A5 size
8/5/98

Appb.fm
Pass 0

R

Transporting the Printer

If you need to transport your printer some distance, carefully repack it using the original box and packing materials, as described below.



Warning:

You will need to move the print head by hand to remove the ribbon cartridge. If you have just used the printer, the print head may be hot; let it cool for a few minutes before touching it.

1. Turn off the printer.
2. Unplug the power cord from the electrical outlet; then disconnect the interface cable from the printer.
3. Remove any paper loaded in the printer, and remove the paper guide. Pull out the paper separator from the paper guide.
4. If a pull tractor is installed, remove it as described on page 2-32. If any options are installed, remove them and pack them in their original boxes.
5. Make sure that the print head is not hot. Then remove the ribbon cartridge as described in Chapter 1.
6. Remove the paper tension unit as described on page 2-22. Attach the protective locking clips on both sides of the printer roller. Then install the paper tension unit as described on page 2-33.
7. Make sure the tractor that comes with your printer is installed in the front push position. See page 2-9 for instructions.
8. Replace the transportation screw using the screwdriver that came with the printer.
9. Repack the printer, ribbon cartridge, paper guide, paper separator, and power cord in the original packing materials and place them in the printer's original box.

B

L

Sun-E+
Pre Rev. C

A5 size
8/5/98

Appb.fm
Pass 0

Proof Sign-off:
<antoname>
<leadername>
<editorname>

Proof Sign-off:
<antoname> _____
<leadername> _____
<editorname> _____

Sun-E+
Pre Rev. C

A5 size
8/5/98

Appc.fm
Pass 0

R

Appendix C

Specifications

Printer Specifications	C-2
Mechanical	C-2
Electrical	C-5
Environmental	C-5
Paper	C-6
Paper alignment	C-9
Printable area	C-10
Safety approvals	C-13
CE marking	C-13
Command Lists	C-14
EPSON ESC/P2 control codes	C-14
IBM 2391 Plus emulation control codes	C-17
Character Tables	C-19
International character sets for the Italic table	C-29

C

L

Sun-E+
Pre Rev. C

A5 size
8/5/98

Appc.fm
Pass 0

Proof Sign-off:
pri<antname> _____
nt<leadname> _____
<editname> _____

Printer Specifications

Mechanical

Printing method:	24-pin impact dot matrix
Printing speed:	High speed draft 480 cps at 10 cpi maximum Draft 360 cps at 10 cpi Letter quality 120 cps at 10 cpi
Printing direction:	Bidirectional logic seeking for text and graphics printing. Unidirectional text or graphics printing can be selected using software commands.
Line spacing:	1/6-inch or programmable in 1/360-inch increments
Printable columns:	136 columns (at 10 cpi)
Resolution:	Maximum 360 × 180 dpi (letter quality) 360 × 360 dpi (raster graphics)
Interfaces:	One standard bidirectional, 8-bit, parallel interface with IEEE 1284 nibble mode support and one optional interface slot
Paper feed methods:	Friction (front or top paper entry) Push tractor (front or rear paper entry) Pull tractor (front, bottom, or rear paper entry) Push and pull tractor (additional tractor is required for front push and pull tractor combination) Cut-sheet feeder (optional) Roll paper holder (optional)
Paper feed speed:	Continuous 5 inches/second Intermittent 60 ms/line at 1/6-inch line spacing

Proof Sign-off:
<fontname>
<leadname>
<editname>

Sun-E+
Pre Rev. C

A5 size
8/5/98

Appc.fm
Pass 0

R

Paper capacity:

High-capacity cut-sheet feeder
up to 150 sheets of 82 g/m² (22 lb) paper
up to 25 plain or bond envelopes
up to 30 airmail envelopes
up to 30 postcards
a stack of multi-part forms up to 15 mm
(0.59 inch) thick

Note:

The total thickness of the paper stack can be up to 15 mm (0.59 inch).

Second-bin cut-sheet feeder
up to 50 sheets of 82 g/m² (22 lb) paper

Note:

The total thickness of the paper stack can be up to 5 mm (0.20 inch)

Buffer:

64KB or 0KB (selectable in the default-setting mode or the EPSON Remote! utility)

C

L

Sun-E+
Pre Rev. C

A5 size
8/5/98

Appc.fm
Pass 0

Proof Sign-off:
<stantname>
<leadername>
<editorname>

Built-in fonts:

Bitmap fonts

EPSON Draft	10, 12, 15 cpi
EPSON Roman	10, 12, 15 cpi, proportional
EPSON Sans Serif	10, 12, 15 cpi, proportional
EPSON Courier	10, 12, 15 cpi
EPSON Prestige	10, 12 cpi
EPSON Script	10 cpi
EPSON OCR-B	10 cpi
EPSON Orator	10 cpi
EPSON Orator-S	10 cpi
EPSON Script C	proportional

Scalable fonts

EPSON Roman	10.5, 8-32 pt (every 2 pt)
EPSON Sans Serif	10.5, 8-32 pt (every 2 pt)
EPSON Roman T	10.5, 8-32 pt (every 2 pt)
EPSON Sans Serif H	10.5, 8-32 pt (every 2 pt)

Barcode fonts

EAN-13, EAN-8, Interleaved 2 of 5, UPC-A, UPC-E, Code 39, Code 128, POSTNET

Character tables:

One Italic and (12) graphical character tables (34) graphical character tables are available in some countries.) See page C-19 for more information on the available character tables.

26から34
に変更

Character sets:

14 international character sets and one legal character set

Reliability:

Total print volume

24 million lines
(except print head)
MTBF 10000 POH (25% duty)

Print head life

400 million strokes/wire

追加

Dimensions and weight:

Height	257 mm (10.1 inches)
Width	639 mm (25.2 inches)
Depth	402 mm (15.8 inches)
Weight	approx. 13 kg (28.8 lb)

Proof Sign-off: _____
<tantaname> _____
<leadename> _____
<editname> _____

Sun-E+
Pre Rev. C

A5 size
8/5/98

Appc.fm
Pass 0

R

Ribbon: Black ribbon cartridge (S015086)
Ribbon life 8 million characters
(LQ, 10 cpi, 48 dots/
character)

Electrical

	120 V Model	220 to 240 V Model
Input voltage range	99 to 132 V	198 to 264 V
Rated frequency range	50 to 60 Hz	
Input frequency range	49.5 to 60.5 Hz	
Rated current	1.0 A (maximum 1.8 A depending on the character type)	0.5 A (maximum 0.9 A depending on the character type)
Power consumption	Approx. 46W (ISO/IEC 10561 letter pattern)	

This product is also designed for IT power systems with Phase to Phase voltage 220 to 240 V.

Note:
Check the label on the back of the printer for the voltage of your printer.

Environmental

	Temperature	Humidity (without condensation)
Operation	5 to 35°C (41 to 95°F)	10 to 80% RH
Storage	-30 to 60°C (-22 to 140°F)	0 to 85% RH



L

Sun-E+
Pre Rev. C

A5 size
8/5/98

Appc.fm
Pass 0

Proof Sign-off:
<antname> _____
<leadname> _____
<editname> _____

Paper

Note:

- Use recycled paper and envelopes only under normal temperature and humidity conditions, as follows:

Temperature 15 to 25°C (59 to 77°C)
Humidity 30 to 60% RH

- Do not load paper that has been folded or is damaged, wrinkled, or curled.

Ordinary single sheets: front and top entry

Width 100 to 420 mm (3.9 to 16.5 inches)
Length Front: 148 to 420 mm (5.8 to 16.5 inches)
Top: 100 to 420 mm (3.9 to 16.5 inches)
Thickness 0.065 to 0.14 mm (0.0025 to 0.0055 inch)
Weight 52 to 90 g/m² (14 to 24 lb)

Single-sheet multi-part forms:

front and top entry

Width 100 to 420 mm (3.9 to 16.5 inches)
Length Front: 148 to 420 mm (5.8 to 16.5 inches)
Top: 100 to 420 mm (3.9 to 16.5 inches)
Copies 1 original + up to 5 copies
Thickness 0.12 to 0.46 mm (0.0047 to 0.018 inch)
Weight 40 to 58 g/m² (12 to 15 lb)
Binding Line glue at the top of form (both front and top entry)
Single side line glue (front entry only)

Envelopes: top entry only

Size No. 6: 165 × 92 mm (6.5 × 3.6 inches)
No. 10: 241 × 105 mm (9.5 × 4.1 inches)
Thickness 0.16 to 0.52 mm (0.0063 to 0.0197 inch)
Weight 45 to 90 g/m² (12 to 24 lb)

Proof Sign-off: _____
<antoname> _____
<leadername> _____
<editorname> _____

Sun-E+
Pre Rev. C

A5 size
8/5/98

Appc.fm
Pass 0

R

Postcards: front and top entry

Width	100 to 148 mm (3.9 to 5.83 inches)
Length	Front: 148 mm (5.83 inches) Top: 100 to 148 mm (3.9 to 5.83 inches)
Thickness	0.22 mm (0.0087 inch)
Weight	192 g/m ² (51 lb)

Continuous paper (standard and multi-part): front, rear, and bottom entry

Width	101.6 to 406.4 mm (4.0 to 16.0 inches)
Length	101.6 to 558.8 mm (4.0 to 22.0 inches)
Copies	1 original + up to 5 copies
Thickness	Printable area 0.065 to 0.46 mm (0.0025 to 0.018 inch) Perforated edges up to 0.9 mm (0.035 inch)
Weight (not multi-part)	52 to 82 g/m ² (14 to 22 lb)
Weight (one sheet of multi-part)	40 to 58 g/m ² (12 to 15 lb)
Binding	Point glue or paper staples on both sides (front, bottom, or rear entry)

Note:

Because thick multi-part forms require a straight paper path, load them in the front slot.

Continuous paper with labels: front and bottom entry

Label size	23.8 × 63.5 mm (15/16 × 2.5 inches) minimum 2.5 mm (0.1 inch) corner radius, minimum
Backing sheet width	101.6 to 406.4 mm (4.0 to 16.0 inches)
Backing sheet length (one page)	101.6 to 558.8 mm (4.0 to 22.0 inches)



L

Sun-E+
Pre Rev. C

A5 size
18/5/98

Appc.fm
Pass 0

Proof Sign-off:
<tantoname>
<leadername>
<editorname>

Backing sheet thickness 0.07 to 0.09 mm (0.0028 to 0.0035 inch)

Total thickness 0.16 to 0.19 mm (0.0063 to 0.0075 inch)

Label weight 68 g/m² (17 lb)

Roll paper: rear entry with optional roll paper holder only

Width 216 ± 3 mm (8.5 ± 0.12 inch)

Thickness 0.07 to 0.09 mm (0.0028 to 0.0035 inch)

Weight 52 to 82 g/m² (14 to 22 lb)

Proof Sign-off:
<fontname> _____
<leadname> _____
<editname> _____

Sun-E+
Pre Rev. C

A5 size
8/5/98

Appc.fm
Pass 0

R

Paper alignment

Front entry

Printing starts at the arrow mark. The unprintable area is to the left of the arrow mark.

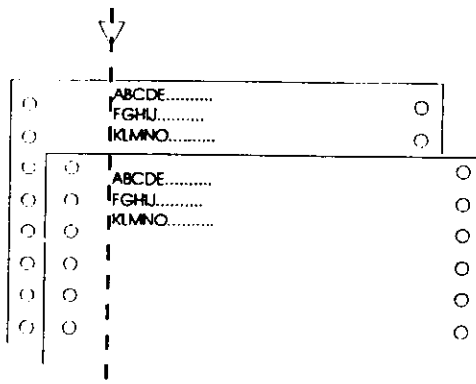

Rear entry

Printing starts at "0" on the scale. The unprintable area is to the left of the "0".

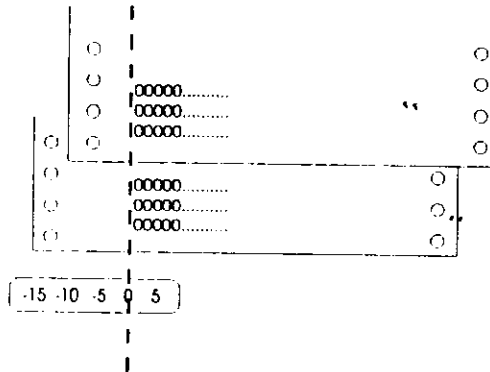

L

Sun-E+
Pre Rev. C

A5 size
8/5/98

Appc.fm
Pass 0

Proof Sign-off:
<antoname>
<leadname>
<editname>

Printable area

Single sheets, envelopes, and postcards:

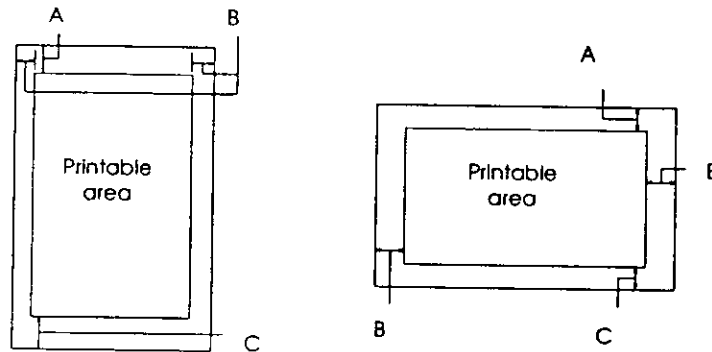

- A The minimum top margin is 4.2 mm (0.17 inch).
- B The minimum left margin is 3.0 mm (0.12 inch).
The minimum right margin is 3.0 mm (0.12 inch).
The maximum width is 420 mm (16.5 inches) and
the maximum printable width is 345.4 mm (13.6 inches).
For single sheets wider than 351.4 mm (13.8 inches), the side margins
increase proportionally to match the width of the paper.
- C The minimum bottom margin is 4.2 mm (0.17 inch).

Proof Sign-off:
<antname>
<leadname>
<editname>

Sun-E+
Pre Rev. C

A5 size
8/5/98

Appc.fm
Pass 0

R

Continuous paper:

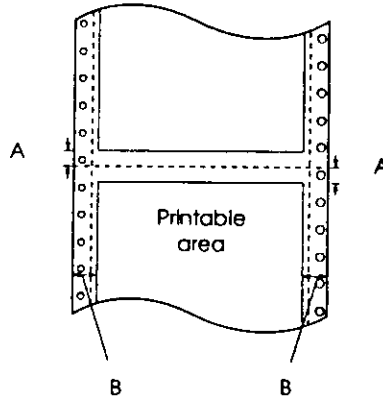

- A The minimum top and bottom margins above and below the perforation are 4.2 mm (0.17 inch) each.
- B The minimum left and right margins are 13 mm (0.51 inch) each. The maximum printable width is 345.4 mm (13.6 inches). The maximum width is 420 mm (16.5 inches) and the maximum printable width is 345.4 mm (13.6 inches). For continuous paper wider than 371.4 mm (14.6 inches), the side margins increase proportionally to match the width of the paper.

C

L

Sun-E+
Pre Rev. C

A5 size
8/5/98

Appc.fm
Pass 0

Proof Sign-off:
<antoname>
<leadname>
<editname>

Roll paper:

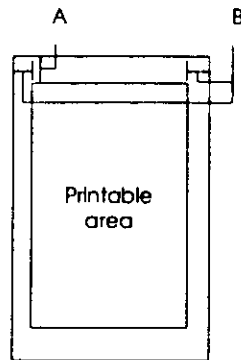

- A The minimum top margin is 4.2 mm (0.17 inch).
- B The minimum left margin is 3.0 mm (0.12 inch).
The minimum right margin is 3.0 mm (0.12 inch).
The maximum printable width is 203.2 mm (8.0 inches).

Proof Sign-off: _____
<tantoname> _____
<leadername> _____
<editorname> _____

Sun-E+
Pre Rev. C

A5 size
8/5/98

Appc.fm
Pass 0

R

Safety approvals

120 V model:

Safety standards UL1950
 CSA C22.2 No. 950

EMI FCC part 15 subpart B class B
 CSA C108.8 class B

230 V model:

Safety standards EN 60950 (TÜV, NEMKO)

EMI EN 55022 (CISPR pub. 22) class B
 AS/NZS 3548 class B

Acoustic noise: Approx. 54 dB (A) (ISO 7779 pattern)

CE marking

230 V model:

Low Voltage Directive 73/23/EEC
EMC Directive 89/336/EEC

EN 60950
EN 55022 Class B
EN 61000-3-2
EN 61000-3-3
EN 50082-1
IEC 801-2
IEC 801-3
IEC 801-4



L

Sun-E+
Pre Rev. C

A5 size
8/5/98

Appc.fm
Pass 0

Proof Sign-off:

<antoname> _____

<leadername> _____

<editorname> _____

Command Lists

Your printer supports the following EPSON ESC/P2 control codes and IBM 2391 Plus emulation control codes.

EPSON ESC/P2 control codes

Selecting an EPSON ESC/P2 printer in your software allows you to use advanced fonts and graphics. See the *ESC/P Reference Manual* for details.

General operation:

ESC @, ESC U, ESC EM

Paper feeding:

FF, LF, ESC 0, ESC 2, ESC 3, ESC +, CR

Page format:

ESC (C, ESC C, ESC C 0, ESC Q, ESC I, ESC (c, ESC N, ESC O

Print position motion:

ESC \$, ESC Y, ESC (V, ESC (n, ESC D, HT, ESC G, VT, ESC J

Font selection:

ESC k, ESC x, ESC y, ESC X, ESC P, ESC M, ESC g, ESC p, ESC 4, ESC 5, ESC E, ESC F, ESC !

Font enhancement:

ESC W, DC4, SO, DC2, SI, ESC w, ESC G, ESC H, ESC T, ESC S, ESC -, ESC (-, ESC q

Spacing:

ESC Space, ESC c, ESC (U

Character handling:

ESC t, ESC (t, ESC R, ESC %, ESC &, ESC :, ESC 6, ESC 7, ESC (^

Bit image:

ESC *

Bar code:

ESC (G, ESC .

Bar code:

ESC (B

L

Sun-E+
Pre Rev. CA5 size
8/5/98Appc.fm
Pass 0

Proof Sign-off:

<tantname> _____

<leadname> _____

<editname> _____

0: The printer adds the HRC.

1: The printer does not add the HRC.

Bit 2 = Position of flag character (for EAN-13 and UPC-A only)

0: Center

1: Under

Bits 3-7 = Not used

Barcode data

Barcode data corresponds to the barcode symbology. The data number of each barcode type is constant. The barcode is printed only if the following valid characters are set.

Barcode type	Number of valid characters 1 (HEX)	Number of valid characters 2 (HEX)
EAN-13	0D	0C
EAN-8	8	7
Interleaved 2 of 5	2 to FF	2 to FF
UPC-A	0C	0B
UPC-E	0C or 8	0B or 7
Code 39	1 to FF	1 to FF
Code 128	2 to FF	2 to FF
POSTNET	6 or 0A or 0C	5 or 9 or 0B

Number of valid characters 1: Control flag c b0=0

Number of valid characters 2: Control flag c b0=1

The valid data for each barcode type is described below. If invalid data is included in the barcode data string, the barcode is not printed.

Barcode type	Barcode data
EAN-13	0-9 (Hex 30-39)
EAN-8	0-9 (Hex 30-39)
UPC-A	0-9 (Hex 30-39)
UPC-E	0-9 (Hex 30-39)
Interleaved 2 of 5	0-9 (Hex 30-39)
POSTNET	0-9 (Hex 30-39)
Code 39	0-9 (Hex 30-39), (Hex 41-5A), (Hex 20, 24, 25, 2B, 2D, 2E, 2F)
Code 128	Set A, Set B, Set C

Proof Sign-off:
<antoname> _____
<leadename> _____
<editorname> _____

Sun-E+
Pre Rev. C

A5 size
8/5/98

Appc.fm
Pass 0

R

The following conditions are required for barcode printing:

- Barcode printing is always performed unidirectionally. However, when it is mixed with raster bit image data, neither barcode nor raster bit image data is printed.
- A barcode is not printed when part of the barcode extends beyond the right margin.
- When barcode data and text data are mixed in a data sequence, barcodes and text are printed in the same place.
- The start and stop (*) characters of Code 39 are added to human readable characters.
- The initial data of Code 128 (Set A, B, or C) is identified as the first data of Code 128, and must be hexadecimal (41, 42, and 43, respectively).
- When Code 128 Set C and Interleaved 2 of 5 are selected, barcode data requires an even number data string. However, if an odd number string is sent, a 0 is automatically added, making it an even number data string.
- The barcode print start position (except for POSTNET) is always 40/360 inch above the baseline.

IBM 2391 Plus emulation control codes

This printer emulates the IBM Proprinter using the commands below. For detailed information, see the IBM 2391 Plus reference manual.

General operation:

NUL, DC3, ESC j, BEL, CAN, DC1, ESC Q, ESC [K, ESC U, ESC [F

Paper feeding:

FF, LF, ESC 5, ESC A, ESC A (AGM^o), ESC 0, ESC 1, ESC 2, ESC 3, ESC 3 (AGM^o), CR, ESC]

Page format:

ESC C, ESC C0, ESC X, ESC N, ESC O, ESC 4

Print position motion:

ESC d, ESC R, ESC D, HT, ESC B, VT, ESC J, ESC J (AGM^o)

Font selection:

DC2, ESC P, ESC :, ESC E, ESC F, ESC I, ESC [d, ESC [I



L

Sun-E+
Pre Rev. C

A5 size
18/5/98

Appc.fm
Pass 0

Proof Sign-off:
<antoname>
<leadename>
<editorname>

Font enhancement:

DC4, SO, ESC SO, ESC W, ESC [@, SI, ESC SI, ESC G, ESC H, ESC T,
ESC S, ESC -, ESC _, ESC [-

Spacing:

BS, SP, ESC [Y

Character handling:

ESC 6, ESC 7, ESC [T, ESC ^, ESC Y

Bit image:

ESC K, ESC L, ESC Y, ESC Z, ESC [g, ESC * (AGM*)

Barcode:

ESC [f, ESC [p

Download:

Download command is not provided.

* Alternate Graphic Mode

Proof Sign-off:
<antname> _____
<leadname> _____
<editname> _____

Sun-E+
Pre Rev. C

A5 size
8/5/98

Appc.fm
Pass 0

R

Character Tables

You can select the character tables shown in this section using the printer's default-setting mode or with software commands.

Note:

- Most of the character tables are the same as the PC 437 table for hex codes 00 through 7F; for these tables, only the characters for hex codes 80 through FF are shown.*
- The character tables with an asterisk (*) after the table name are available only in some countries.*

PC 437 (USA, Standard European)



L

Sun-E+
Pre Rev. C

A5 size
8/5/98

Appc.fm
Pass 0

Proof Sign-off:
<antoname>
<leadername>
<editorname>

PC 850 (Multilingual)

PC 860 (Portuguese)

PC 863 (Canadian-French)

PC 865 (Norwegian)

Proof Sign-off:
<tantoname> _____
<leadername> _____
<editorname> _____

Sun-E+
Pre Rev. C

A5 size
8/5/98

Appc.fm
Pass 0

R

PC 861 (Icelandic)

BRASCII (Brazilian Portuguese)

Abicomp (Brazilian Portuguese) ISO Latin 1

C

L

Sun-E+
Pre Rev. C

A5 size
8/5/98

Appc.fm
Pass 0

Proof Sign-off:
<tantoname>
<leadername>
<editorname>

Roman 8

*PC 437 Greek (Greek)**

*PC 869 (Greek)**

Proof Sign-off:
<tantoname> _____
<leadername> _____
<editorname> _____

Sun-E+
Pre Rev. C

A5 size
8/5/98

Appc.fm
Pass 0

R

*ISO 8859-7 (Latin/Greek)** *PC 853 (Turkish)**

*PC 857 (Turkish)**

*ISO Latin 1T (Turkish)**

C

L

Sun-E+
Pre Rev. C

A5 size
18/5/98

Appc.fm
Pass 0

Proof Sign-off:
<tantoname>
<leadename>
<editoname>

*PC 855 (Cyrillic)**

*PC 866 (Russian)**

*PC 852 (East European)**

*MAZOWIA (Polish)**

Proof Sign-off:
<lastname>
<leadname>
<editname>

Sun-E+
Pre Rev. C

A5 size
8/5/98

Appc.fm
Pass 0

R

*Code MJK (CSFR)**

*Bulgaria**

*Estonia**

*PC 774 (LST 1283:1993)**

C

L

Sun-E+
Pre Rev. C

A5 size
18/5/98

Appc.fm
Pass 0

Proof Sign-off:
<antoname>
<leadname>
<editname>

*ISO 8859-2**

*PC 866 LAT. (Latvian)**

*PC 866 UKE (Ukrainian)**

*PC APTEC. (Arabic)**

Proof Sign-off:
<fontname>
<leadname>
<editname>

Sun-E+
Pre Rev. C

A5 size
8/5/98

Appc.fm
Pass 0

R

*PC 708 UKR (Arabic)**

*PC 720 (Arabic)**

*PC AR 864 (Arabic)**

*PC 860 (Portuguese)**

C

L

Sun-E+
Pre Rev. C

A5 size
18/5/98

Appc.fm
Pass 0

Proof Sign-off:
<tantoname>
<leadername>
<editorname>

*PC 861 (Icelandic)**

PC 868

*PC 865 (Nordic)**

ISO 8859-15

Proof Sign-off:
<antoname> _____
<leadename> _____
<editorname> _____

Sun-E+
Pre Rev. C

A5 size
8/5/98

Appc.fm
Pass 0

R

PC 858

追加しました。

Italic

C

No character is available
for hex code 15 in the
Italic table

L

Sun-E+
Pre Rev. C

A5 size
18/5/98

Appc.fm
Pass 0

Proof Sign-off:
<antoname>
<leadname>
<editname>

International character sets for the Italic table

You can select one of the following eight international character sets for the Italic character table shown below using the default-setting mode or the ESC R command. For example, when you select "Italic France," the characters in the "France" row are used in the Italic character table.

You can select one of the following seven additional sets only with the ESC R command.

Proof Sign-off:
<stantoname> _____
<leademame> _____
<editorname> _____

Sun-E+
Pre Rev. C

A5 size
8/5/98

Appd.fm
Pass 0

R

Appendix D

Customer Support Information

Contacting Customer Support.....	D-2
For North American Users.....	D-2
For United Kingdom and the Republic of Ireland Users.....	D-4
Enquiry Desk.....	D-4
Customer Support.....	D-4
Faxon EPSON.....	D-5
EPtec - Bulletin Board Service for latest drivers and utilities.....	D-5
World Wide Web.....	D-5
For Australian Users.....	D-6
EPSON FAXBACK.....	D-6
EPSON Bulletin Board System.....	D-6
Internet URL http://www.epson.com.au	D-6
Your dealer.....	D-6
EPSON Helpdesk.....	D-7
For Singapore Users.....	D-7
For Hong Kong Users.....	D-7
Internet home page.....	D-8
Electronic bulletin board system.....	D-8
Technical support hotline.....	D-8
For Philippines Users.....	D-8

D

L

**Sun-E+
Pre Rev. C**

A5 size
8/5/98

Appd.fm
Pass 0

Proof Sign-off:
<tantoname>
<leadername>
<editoname>

Contacting Customer Support

If your printer is not operating properly and you cannot solve the problem using the troubleshooting information in Chapter 7, contact customer support services for assistance. See the section for your country below.

We will be able to help you much more quickly if you give us the following information:

Printer model:

Serial number of your printer:
(The serial number label is on the back of the printer.)

Brand and model of your computer:

Printer software version:
(Click the About button in your printer driver.)

Windows version (for example, NT, 95, or 3.1):

Software application(s) you normally use with the printer and their version number(s):

For North American Users

If you purchased your printer in the United States or Canada, EPSON provides customer support through the following services:

Electronic support services

Service	Access
World Wide Web	From the Internet, you can reach EPSON's home page at http://www.epson.com .
EPSON Internet FTP Site	If you have Internet FTP capability, use your Web browser (or other software for FTP downloading) to log onto ftp.epson.com with the user name anonymous and your e-mail address as the password.
EPSON Download Service	You can call the EPSON Download Service at (800) 442-2007 . Set your communications software to 8 data bits, 1 stop bit, no parity. Modem speed can be up to 28.8 Kbps.
EPSON Forum on CompuServe®	Members of CompuServe can type GO EPSON at the menu prompt to reach the Epson America Forum. For a free introductory CompuServe membership, call (800) 848-8199 and ask for representative #529.

Proof Sign-off:
<antfname> _____
<leadername> _____
<editorname> _____

Sun-E+
Pre Rev. C

A5 size
8/5/98

Appd.fm
Pass 0

R

Automated telephone services

Service	Access
EPSON SoundAdvice™	For pre-recorded answers to commonly asked questions about EPSON products 24 hours a day, seven days a week, call (800) 442-2110 .
EPSON FaxAdvice™	Access EPSON's technical information library by calling (800) 442-2110 . You must provide a return fax number to use this service.
EPSON Referral Service	For the location of your nearest Authorized EPSON Reseller or Customer Care Center, call (800) 442-2110 .

EPSON also provides technical support and information on the installation, configuration, and operation of EPSON products. Dial **(800) 922-8911**, **(310) 782-2600** (U.S.), or **(905) 709-9475** (Canada), 6 A.M. to 6 P.M., Pacific Time, Monday through Friday.

Before you call, please have the following information ready:

- Product name
- Product serial number
- Computer configuration
- Description of the problem

You can purchase ink cartridges, paper, manuals, accessories, and parts from EPSON Accessories at **(800) 873-7766** (U.S. sales only). In Canada, please call **(800) 873-7766** for dealer referral.

Note:

If you need help using software with an EPSON product, see the documentation for that program for technical support information.

D

L

Sun-E+
Pre Rev. C

A5 size
8/5/98

Appd. fm
Pass 0

Proof Sign-off:
<antname> _____
<leadname> _____
<editname> _____

For United Kingdom and the Republic of Ireland Users

If you purchased your printer in the UK or the Republic of Ireland, Epson (UK) Limited provides a range of customer services and technical support.

Note:

For customers in the Republic of Ireland, please use the correct dialing codes when dialing the UK telephone numbers listed in the following sections. For example the Enquiry Desk fax number, 01442 227271, should be dialed as 0044 1442 227271 from the Republic of Ireland.

Enquiry Desk

The Enquiry Desk team can be contacted by calling 0800 220546 in the UK or 1 800 409132 from the Republic of Ireland, by faxing 01442 227271, or via the Internet at info@epson.co.uk. They can provide the following information:

- Information and literature on new EPSON products (also available from Faxon EPSON)
- Where to purchase genuine EPSON consumables, accessories and options

Customer Support

Our Customer Support team can provide the following services:

- Technical information on installing, configuring, and operating your EPSON products
- Arranging for faulty EPSON products to be repaired within the warranty period

For information on contacting our Customer Support team, please see the Service and Support Information booklet that came with your EPSON product.

If this booklet is not available, details can be found on Faxon EPSON faxback service, EPtec Bulletin Board Service or on EPSON's World Wide Web site. See below for details.

Proof Sign-off:
<antoname> _____
<leadename> _____
<editname> _____

Sun-E+
Pre Rev. C

A5 size Appd.fm
8/5/98 Pass 0

R

Faxon EPSON

Contact Faxon EPSON Faxback Service for:

- Literature and specifications on the latest EPSON products
- Support information including troubleshooting tips, switch settings and driver information

To use Faxon EPSON, call 01442 227332 using a touch-tone phone. You will be asked to follow a simple routine to register your document request and once you have entered your telephone and fax numbers, Faxon EPSON will fax a copy of the document catalogue to your fax machine.

When you have found the documents that you need in the catalogue, call Faxon EPSON again and enter the document ID numbers. The documents will be faxed to you automatically.

EPtec - Bulletin Board Service for latest drivers and utilities

You can call the EPSON Bulletin Board Service on 01442 227479. No membership is required. Make sure that your communications software is set to 8 data bits, 1 stop bit, no parity bit, ANSI terminal mode emulation and a modem speed of up to 28.8 Kbps. Downloading protocols supported include Xmodem, Ymodem and Zmodem. See the documentation that came with your communications software and modem for more information.

When you first connect to the Bulletin Board Service, you will be asked for your name, company name, phone number and a password (which you can invent yourself).

World Wide Web

If you can connect to the Internet and have a Web browser, you can access EPSON's World Wide Web site at <http://www.epson.com>. Here you will find information on the latest EPSON products, software drivers, and answers to frequently asked questions.

D

L

Sun-E+
Pre Rev. C

A5 size
8/5/98

Appd.fm
Pass 0

Proof Sign-off:
<tantoname> _____
<leadername> _____
<editoname> _____

For Australian Users

EPSON Australia wishes to provide you with a high level of Customer Service. As well as this *User's Guide*, we provide the following sources for obtaining information:

EPSON FAXBACK

EPSON FAXBACK will fax you the latest specifications and pricing for most EPSON products offered in Australia. There is also technical information including details of the latest software and drivers available. Phone (02) 9903 9075 and the system will guide you through a number of choices before faxing the information to your fax machine.

EPSON Bulletin Board System

This is where you can download the latest software and drivers. Visit the BBS to check out the latest versions. If you have a modem, phone (02) 9417 5090.

Internet URL <http://www.epson.com.au>

Access the Epson Australia World Wide Web pages. Worth taking your modem here for the occasional surf! You can get the same information as offered on the EPSON FAXBACK and the EPSON Bulletin Board plus more.

Your dealer

Don't forget that your dealer can often help identify and resolve problems. The dealer should always be the first call for advice on problems. They can often solve problems quickly and easily as well as give you advice on the next step to take.

Proof Sign-off:
<antoname>
<leadername>
<editomame>

Sun-E+
Pre Rev. C

A5 size
8/5/98

Appd.fm
Pass 0

R

EPSON Helpdesk

EPSON Helpdesk is provided as a final backup to make sure our clients have access to advice. Operators on the Helpdesk can aid you in diagnosing hardware and software problems. They can also advise you on the latest EPSON products and where the nearest dealer or service agent is located. Many types of queries are answered here.

The Helpdesk numbers are:

Phone: (02) 9903 9040
Fax: (02) 9903 9189

We encourage you to have all the relevant information on hand when you ring. The more information you prepare, the faster we can help solve the problem. This information includes the *User's Guide* for your EPSON product, type of computer, operating system, application programs, and any other information you feel is required.

For Singapore Users

Contact the telephone and fax numbers below.

Phone: (065) 337-7911
Fax: (065) 334-1185

For Hong Kong Users

To obtain technical support as well as other after-sales services, users are welcome to contact EPSON Hong Kong Limited.

D

L

Sun-E+
Pre Rev. C

A5 size
8/5/98

Appd.fm
Pass 0

Proof Sign-off:
<tantaname>
<leadername>
<editorname>

Internet home page

EPSON Hong Kong has established a local home page in both Chinese and English on the Internet to provide users with the following information:

- Product information
- Answers to Frequently Asked Questions (FAQs)
- Latest versions of EPSON printer drivers

Users can access our World Wide Web home page at <http://www.epson.com.hk>.

Electronic bulletin board system

An electronic bulletin board system (BBS) is also available to obtain printer information and the latest versions of printer drivers. You can log onto the following number for the BBS service:

BBS: (852) 2827-4244

Technical support hotline

You can also contact our technical staff at the telephone and fax numbers below.

Phone: (852) 2585-4399
Fax: (852) 2827-4383

For Philippines Users

To obtain technical support as well as other after sales services, users are welcome to contact the EPSON Philippines Representative Office at the telephone and fax numbers below.

Phone: (632) 813-6552
Fax: (632) 813-6545
BBS: (632) 814-0595

Glossary

ASCII

American Standard Code for Information Interchange. A standardized coding system for assigning numerical codes to letters and symbols.

auto line feed

When this setting is turned on using the default-setting mode or the EPSON Remote! utility, each carriage return (CR) code is automatically followed by a line feed (LF) code.

bidirectional printing

Printing in which the print head prints in both directions (bidirectionally). This increases the print speed but may reduce precise vertical alignment. Bidirectional printing is the printer's standard printing mode. *See also* unidirectional printing.

buffer

The portion of the printer's memory used to store data before it is printed.

character table

A collection of letters, numbers, and symbols that constitute the set of characters used in a particular language.

characters per inch (cpi)

A measure of the size of text characters. *See also* pitch.

continuous paper

Paper that has sprocket-feed holes on both sides, is perforated between pages, and is supplied in a folded stack. Also called fanfold paper.

control code

A special code used to control a printer function such as a carriage return or line feed.

cpi

See characters per inch.

cut-sheet feeder

An optional, detachable device that automatically feeds single sheets of paper into the printer.

data dump

See hex dump.

default

A value or setting that takes effect when the equipment is turned on, reset, or initialized. Also known as a factory setting.

dithering

A halftoning method in which dots are printed in a predetermined pattern to simulate a shade or tone. Dithering works best for images with solid colors, such as charts and graphs. *See also* halftoning.

dot matrix

A method of printing in which each letter or symbol is formed by a pattern (matrix) of individual dots.

draft

The print mode used by your printer when you select Draft as the font. The Draft font uses fewer dots per character for faster printing. *See also* high-speed draft and near letter quality.

driver

See printer driver.

ESC/P2

The enhanced version of the ESC/P printer command language. Commands in this language produce laser-like features, such as scalable fonts and enhanced graphics printing.

fanfold paper

See continuous paper.

font

A style of type designated by a name such as Roman or Sans Serif.

form feed (FF)

A control panel button and control code that advances the paper to the next top-of-form position.

halftoning

A method of using dot patterns to represent an image. Halftoning makes it possible to produce varying shades of gray using only black dots, or a nearly infinite array of colors using only a few colors of dots.

hex dump

A troubleshooting feature that helps identify the cause of communication problems between the printer and the computer. When the printer is in hex dump mode, it prints each code that it receives in hexadecimal notation and as ASCII characters. Also called data dump.

high-speed draft

A draft printing mode you can select using the printer's default-setting mode or the EPSON Remote! utility. High-speed draft uses a minimum number of dots per character to produce extremely high-speed printing. *See also* draft and near letter quality.

interface

The connection (via a cable) between the computer and the printer over which print data is transmitted to the printer.

ESC/P の記述
でしたので ESC/P2
の記述に変更しました。

Proof Sign-off:
<antname> _____
<leadname> _____
<editname> _____

Sun-E+
Pre Rev. C

A5 size
8/5/98

Glossary.fm
Pass 0

R

landscape

Printing that is oriented sideways on the page. This orientation gives you a page that is wider than it is high and is useful for printing spreadsheets. *See also* portrait.

line feed (LF)

A control panel button and control code that advances the paper one line space.

micro adjust

A printer feature that allows you to precisely adjust the tear-off and top-of-form positions.

paper positions

There are three paper positions for continuous paper printing: standby, tear-off, and top-of-form. For single sheet printing, there is only the top-of-form position. *See also* standby position, tear-off position, and top-of-form position. For detailed information on these positions, *see* "Paper positions" on page 5 of the Glossary.

pitch

The size of the font, which is measured in the number of characters per inch (cpi). The standard is 10 cpi. *See also* characters per inch.

platen

The black roller that provides a backing for the paper during printing.

portrait

Printing that is oriented upright on the page (as opposed to landscape, in which printing is sideways on the page). This is the standard orientation for printing letters or documents. *See also* landscape.

printable area

The area of a page on which the printer can print. It is smaller than the physical size of the page due to margins.

printer driver

A software program that runs, or "drives," a printer. Printer drivers send commands to your printer to tell it how to print your print job.

proportional font

A font whose characters take up varying amounts of horizontal space depending on the width of the character. Thus the uppercase M takes up more horizontal space than the lowercase l.

reset

To return a printer to its default settings.

resolution

A measure of the amount of detail that can be represented. Resolution of printed images is measured using the number of dots per inch (dpi).

self test

A method used to check the operation of the printer. When you run the self test, the printer prints the characters stored in its ROM (Read Only Memory).

standby position

The position of your continuous paper when it is attached to the tractor but not loaded in the printer. *See also* page 5 of the Glossary.

Tear Off Bin button

A control panel button that feeds the perforation of continuous paper to the tear-off position, and when pressed again, feeds the paper back to the top-of-form position.

tear-off position

The position of your continuous paper when you finish printing if auto tear-off mode is on or if you press the Tear Off/Bin button. Using the micro adjust feature, you can adjust the tear-off position so that the paper's perforation is aligned with the printer's tear-off edge. *See also* page 5 of the Glossary.

top-of-form position

The position on the paper that the printer recognizes as the first printable line. This is the default top margin position. *See also* page 5 of the Glossary.

unidirectional printing

Printing in which the print head prints in one direction only. Unidirectional printing is useful for printing graphics because it provides precise vertical alignment. You can select unidirectional printing using the printer's default-setting mode or the EPSON Remote! utility. *See also* bidirectional printing.

Paper positions

Standby position

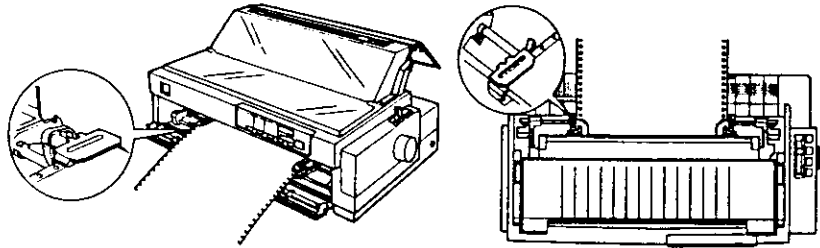

In the standby position, your paper is attached to the printer but is not inside the printer.

Tear-off position

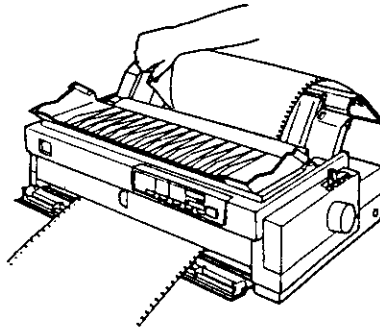

Tear off your printed document at the printer's tear-off edge.

Top-of-form position

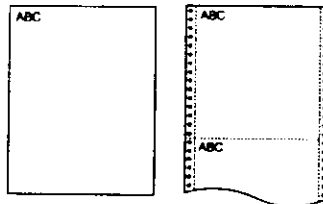

The letters ABC above are printed at the top-of-form position.

new13.eps

new12.eps

1-1.eps

g-e.eps

L

Sun-E+
Pre Rev. C

A5 size
8/5/98

Glossary.fm
Pass 0

Proof Sign-off:
<tantaname>
<leadername>
<editomame>

Index

A

- Accessing,
 - printer driver. *See* Printer driver.
 - EPSON Status Monitor 2, 6-4
- Adjusting
 - tear-off position, 4-3-4
 - top-of-form position, 2-36-40
- Advancing to the tear-off edge, 2-41-43
- AGM, 5-5, 5-8
- Aligning vertical lines, 7-17-18
- Alternate graphic Mode, 5-5, 5-8
- Attaching
 - front paper guide, 2-14
 - paper guide, 1-11-12
 - paper separator, 1-11-12
 - printer cover, 1-11
- Auto tear-off mode, 2-42, 5-6

B

- Background monitoring, 6-11-12
- Beeper pattern, 7-2-3. *See also* Buzzer.
- Bin, A-10. *See also* Tear Off/Bin button.
- Built-in font, 5-2-3, 5-5, 5-8
- Buttons, inside front cover
- Buzzer, 5-8

C

- Center support, A-6
- Choosing a place for the printer, 1-4
- Cleaning the printer, B-2
- Command lists, C-14-18
- Connecting the printer, 1-14-15
- Continuous paper
 - multi-part forms, 2-5-7
 - printing, 4-7, 2-1-43
 - positioning, 1-5
 - problems, 7-8
 - with labels, 2-9

- Control panel, inside front cover,
5-2-10
- Cut-sheet feeder
 - installing, A-4-5
 - loading paper, A-6-9
 - selecting the paper source, A-10
 - switching between continuous
paper printing, A-11

D

- Default-setting mode, 5-4, 5-9-10
- Default settings, 5-4-10
- Double-bin cut-sheet feeder, A-4-5. *See also* cut-sheet feeder.

E

- Edge guides, 2-14, inside back cover
- ENERGY STAR compliance, 13
- EPSON ESC/P2 control codes,
C-14-17
- EPSON Remote! utility, 4-24
- EPSON Status Monitor 2, 4-2, 6-2-12
 - accessing, 6-4
 - installing, 6-3
 - window, 6-4-10
- Error indicators, 7-2-3

F

- Font
 - button, inside front cover
 - light, inside front cover
 - selecting, 5-2-3, 5-5, 5-8
- Front
 - edge guides, 3-11, inside back
cover
 - paper guide, 2-9-11, 2-14, 3-11,
inside back cover
 - paper slot, 6, 9, 3-2-3, 3-10-12
 - push tractor, 4, 6, 2-10-17

L

Sun-E+
Pre Rev. C

A5 size
8/5/98

Index.fm
Pass 0

Proof Sign-off:
<tantoname> _____
<leadername> _____
<editorname> _____

G

Guide
 ribbon, 1-8
 paper, 1-11, inside back cover

H

Hex dump, 7-19-20
High-capacity cut-sheet feeder, A-2,
 A-4-11. *See also* cut-sheet feeder.
High-speed draft setting, 5-8
High-speed printing, 1. *See also* High-
 speed draft setting.

I

IBM 2391 Plus emulation codes,
 C-17-18
Installing
 EPSON Status Monitor 2, 6-3
 front paper guide, 2-14
 front push tractor, 2-10-11
 interface card, A-17
 paper tension unit, 2-35
 printer cover, 1-11
 printer driver, *See also* printer
 driver installing.
 ribbon cartridge, 1-6-11
 roll paper holder, A-13
 tractor in the pull position, 2-24-25
Interface cards, A-3,
 installing, A-17
International character sets, C-29

L

Levers
 Paper release, 2, 2-3-4
 Paper selection, A-9, A-11
 Paper set, A-8-9
 Paper thickness, 2-4-5. *See also*
 Paper thickness lever.
 Paper type, A-8
LF/FF button, inside front cover
Lights, inside front cover

Load/Eject button, inside front cover
Loading

 continuous multi-part forms,
 2-6-8
 continuous paper with labels,
 2-7-8
 envelopes, 3-6-7
 paper onto
 front push tractor, 2-11-15
 rear push tractor, 2-18-21
 pull tractor, 2-25-30
 postcards, 3-7
 roll paper, A-14-16
 single-sheet multi-part forms,
 3-4-5
 single sheets in
 front paper slot, 3-10-12
 top paper slot, 3-8-10

K

Knob
 printer, 7-16, inside back cover
 ribbon-tightening, 1-8

M

Micro adjust
 feature, 3
 mode, 2-38, 2-42
Monitoring Preferences, 6-10-12

O

Operate button, inside front cover
Options, 10, A-2-18

P

Paper entry slots, 6, 3-2
Paper guide, inside back cover
 attaching, 1-11-12
 cover, 1-12, inside back cover
 cut-sheet feeder, A-7
Paper jam, cleaning, 7-16
Paper Out light, inside front cover

Proof Sign-off:
<antoname> _____
<leadname> _____
<editname> _____

Sun-E+ Pre Rev. C

A5 size Index.fm
8/5/98 Pass 0

R

Paper paths, 2-10,
Paper release lever, 2, 2-3-4, inside
back cover
Paper selection lever, A-9, A-11
Paper set lever, A-8-9
Paper separator, inside back cover
attaching, 1-11-12
Paper stacker, A-7
Paper tension unit, inside back cover
installing, 2-35
removing, 2-24
Paper thickness lever, inside back
cover, 2-4-5
Paper type lever, A-8
Pause
button, inside front cover
light, inside front cover
Pitch
button, inside front cover
light, inside front cover
selecting, 5-2-3
Plastic ribbon cover, 2-39
Plugging in the printer, 1-13
Printer cover, inside back cover
installing, 1-11
removing, 1-7
Printer driver
accessing,
from NT 3.5x, 4-19-21
from NT 4.0, 4-13-15
from Windows 3.1, 4-9-11
from Windows 95/98, 4-3-5
installing,
for DOS, 1-18
for NT 3.5x, 1-17-18
for NT 4.0, 1-16-17
for Windows 3.1, 1-17-18
for Windows 95/98, 1-16-17
settings,
for DOS, 1-18
for NT 3.5x, 4-22-23
for NT 4.0, 4-15-18
for Windows 3.1, 4-11-12
for Windows 95/98, 4-5-8
Printer parts, inside back cover
Printer software, 4-2
Printer Status window, 6-9-10

Print head caution symbol, 12
Printing on
continuous paper, 2-1-43
continuous paper with labels,
2-7-9
continuous multi-part forms,
2-5-7
envelopes, 3-6-7
postcards, 3-7
single sheets, 3-1-12
single-sheet multi-part forms,
3-4-5
Pull tractor, 5, 6, 2-23-35, A-2
Push and pull tractor combination, 7,
2-31-34
Push tractor, 4, 5

R

Rear push tractor, 5, 2-18-21
Removing
continuous paper with labels, 2-9
front paper guide, 2-10-11
front push tractor, 2-17
paper tension unit, 2-24
printed document from
front push tractor, 2-15-16
rear push tractor, 2-22-23
printer cover, 1-7
pull tractor, 2-34-35
roll paper, A-16
Ribbon cartridge, 10, 1-6-11
Ribbon cover, 2-39
Ribbon guide, 1-8
Ribbon installation position, 1-7
Ribbon-tightening knob, 1-8
Roll paper holder, A-3, A-12-16
assembling, A-12-13
installing, A-13
loading roll paper, A-14-16
removing, A-16
Roll paper mode, 5-5, 5-9

S

Safety instructions, 11-12

L

Sun-E+
Pre Rev. C

A5 size
18/5/98

Index.fm
Pass 0

Proof Sign-off:

<antoname> _____

<leadname> _____

<editname> _____

- Screwdriver, 1-2-3, B-3
- Second-bin cut-sheet feeder, A-2, A-4
- Selecting,
 - built-in font, 5-2-3, 5-5, 5-8
 - pitch, 5-2-3
- Self test, 7-18-19
- Separator
 - paper, 1-11-12, inside back cover
 - ribbon cartridge, 1-8
- Setting
 - paper release lever, 2-3-4
 - paper thickness lever, 2-4-5
- Shield plate, A-17, inside back cover
- Single sheets
 - printing, 8, 3-1-12
 - problems, 7-6-7
- Specifications, C-2-30
 - CE marking, C-13
 - character tables, C-19-30
 - command lists, C-14-18
 - electrical, C-5
 - environmental, C-5
 - mechanical, C-2-5
 - paper, C-6-8
 - paper alignment, C-9
 - printable area, C-10-12
 - safety approvals, C-13
- Status Monitor 2 utility, 4-2, 6-2-12
- Switching
 - between continuous paper and single sheet, 2-36-37, 4-11
- T**
- Tear off
 - adjusting, 2-43-44
 - edge, 2-15, 2-41
 - feature, 2
 - position, 2-41-43
 - problems, 7-10
- Tear Off/Bin
 - button, inside front cover, 2-41-42
 - lights, inside front cover
- Top-of-form
 - adjusting, 2-38-40
 - position, 2-38
 - problems, 7-9
- Top (paper) slot, 8, 3-2, 3-8-10
- Tractor
 - combination, 2-31-35
 - front push, 4, 5, 2-10-17
 - pull, 5, 6, 2-23-35, A-2
 - rear push, 5, 2-16-21
- Transportation screw, 1-3, B-3
- Transporting the printer, B-3
- Troubleshooting, 7-2-20
 - aligning vertical lines, 7-17-18
 - cleaning paper jams, 7-16
 - continuous paper loading or feeding problems, 7-8
 - error indicators, 7-2-3
 - hex dump, 7-19-20
 - power supply problems, 7-5
 - printing or printout quality problems, 7-11-15
 - self test, 7-18-19
 - single-sheet paper loading or feeding problems, 7-6-7
 - tear-off position problems, 7-10
 - top-of-form position problems, 7-9
- U**
- Unpacking the printer, 1-2
- Using
 - front push tractor, 2-10-17
 - rear push tractor, 2-18-21
 - pull tractor, 2-23-35
 - push and pull tractor combination, 2-31-34 ..
- Utility
 - EPSON Remotel, 4-21
 - EPSON Status Monitor 2, 4-2, 6-2-12 ..
- V**
- Vertical line, aligning, 7-17-18