

**— User's Manual —**

**EPSON**

**EPL-N4000**

**XYA-1**

Proof Sign-off:  
M.Takata  
K.Nishi  
K.Pipa

**Flamingo**  
**Rev. C**

A5 size  
7/24/98

Front.fm  
Pass 0

R

**EPSON®**

Laser Printer

**EPL-N4000**

All rights reserved. No part of this publication may be reproduced, stored in a retrieval system, or transmitted in any form or by any means, mechanical, photocopying, recording, or otherwise, without the prior written permission of SEIKO EPSON CORPORATION. No patent liability is assumed with respect to the use of the information contained herein. Neither is any liability assumed for damages resulting from the use of the information contained herein.

Neither SEIKO EPSON CORPORATION nor its affiliates shall be liable to the purchaser of this product or third parties for damages, losses, costs, or expenses incurred by purchaser or third parties as a result of: accident, misuse, or abuse of this product or unauthorized modifications, repairs, or alterations to this product, or (excluding the U.S.) failure to strictly comply with SEIKO EPSON CORPORATION's operating and maintenance instructions.

SEIKO EPSON CORPORATION shall not be liable against any damages or problems arising from the use of any options or any consumable products other than those designated as Original Epson Products or Epson Approved Products by SEIKO EPSON CORPORATION.

EPSON and EPSON ESC/P are registered trademarks and EPSON ESC/P 2 is a trademark of SEIKO EPSON CORPORATION.

Speedo, Fontware, FaceLift, Swiss, and Dutch are trademarks of Bitstream Inc.

CG Times and CG Omega are registered trademarks of Miles, Inc.

Univers is a registered trademark of Linotype AG and/or its subsidiaries.

Antique Olive is a trademark of Fonderie Olive.

Albertus is a trademark of Monotype Corporation plc.

Coronet is a trademark of Ludlow Industries (UK) Ltd.

Arial and Times New Roman are registered trademarks of Monotype Corporation plc.

HP and HP LaserJet are registered trademarks of Hewlett Packard.

Adobe and PostScript are trademarks of Adobe Systems Incorporated, which may be registered in certain jurisdictions.

*General Notice: Other product names used herein are for identification purposes only and may be trademarks of their respective owners. EPSON disclaims any and all rights in those marks.*

Copyright © 1998 by SEIKO EPSON CORPORATION, Nagano, Japan

 Printed on Recycled Paper.

Reference Guide

Proof Sign-off:  
M.Takata  
K.Nishi  
K.Pipa

\_\_\_\_\_  
\_\_\_\_\_  
\_\_\_\_\_

**Flamingo**  
**Rev. C**

A5 size  
7/16/98

FLAMINGO.TOC  
Pass 0

R

---

## **Contents**

### ***Getting Started***

---

About This Guide .....	2
About Your Printer .....	3
Features .....	3
Options .....	4
ENERGY STAR Compliance .....	6
About Making Printer Settings .....	6
Printer Driver .....	7
OneTouch modes .....	7
SelecType .....	7
Safety Information .....	8
Ozone safety .....	10
Laser Printer Precautions .....	11
Important Safety Instructions .....	13
For United Kingdom Users .....	15
Warnings, Cautions, and Notes .....	16

### ***Chapter 1 Printing with the EPL-N4000***

---

Precaution for printing .....	1-2
Choosing Paper .....	1-2
Labels .....	1-3
Envelopes .....	1-3
Colored paper .....	1-3
Transparencies .....	1-3
Printing Operation .....	1-4
Loading paper in the MP (Multi Purpose) Tray .....	1-4
Loading paper in the lower cassettes .....	1-6
Selecting the paper size .....	1-10
Special Printing Operations .....	1-10
Loading an uncommon paper size .....	1-10
Printing one sheet at a time .....	1-11
Offset stacking mode .....	1-12

Proof Sign-off:  
M.Takata  
K.Nishi  
K.Pipa

\_\_\_\_\_  
\_\_\_\_\_  
\_\_\_\_\_

**Flamingo  
Rev. C**

A5 size  
7/16/98

FLAMINGO.TOC  
Pass 0

R

Emulation Menu .....	4-7
Printing Menu .....	4-8
Tray Size Menu .....	4-11
Config Menu .....	4-12
Setup Menu .....	4-15
Parallel Menu .....	4-17
Network Menu .....	4-18
AUX Menu .....	4-19
LJ4 Menu .....	4-20
GL2 menu .....	4-21
PS3 menu .....	4-23
ESCP2 and FX menus .....	4-24
I239X menu .....	4-27

**Chapter 5 Troubleshooting and Maintenance**

Introduction .....	5-2
Preventing Paper Feed and Paper Jam Problems .....	5-2
Clearing Paper Jams .....	5-3
Print Quality Problems .....	5-16
Option Problems .....	5-20
Other Problems .....	5-20
Status and Error Messages .....	5-23
Hex Dump Mode .....	5-33
Replacing the Imaging Cartridge .....	5-34
Optimizing Print Quality .....	5-38
Resolution Improvement Technology .....	5-38
Adjusting print density .....	5-38
Enhanced MicroGray .....	5-39
Resetting the Printer .....	5-40
Cleaning the Printer .....	5-40
Cleaning inside cover A .....	5-40
Cleaning the printer case .....	5-42
Transporting the Printer .....	5-42
Finding a new place for the printer .....	5-43

Proof Sign-off:  
M.Takata  
K.Nishi  
K.Pipa

\_\_\_\_\_  
\_\_\_\_\_  
\_\_\_\_\_

**Flamingo  
Rev. C**

A5 size  
7/16/98

FLAMINGO.TOC  
Pass 0

R

---

I239X Emulation Commands .....	C-16
Page format .....	C-16
Text .....	C-17
Auxiliary functions .....	C-18
AGM mode .....	C-19

---

**Appendix D Working with Fonts**

Printer and Screen Fonts .....	D-2
Available Fonts .....	D-3
Adding More Fonts .....	D-6
Downloading fonts .....	D-6
Selecting Fonts .....	D-6

---

**Appendix E Map of SelectType Menus**

Switching between SelectType Menus .....	E-2
--	-----

---

**Glossary**

---

Proof Sign-off:  
M.Takata  
K.Nishi  
K.Pipa

\_\_\_\_\_  
\_\_\_\_\_  
\_\_\_\_\_

**Flamingo**  
**Rev. C**

A5 size  
7/16/98

INTRO.FM  
Pass 0

R

---

## Getting Started

The EPSON EPL-N4000 printer combines high performance and reliability with a wide range of features.

To get started with your laser printer, please:

- Read the safety information, laser printer precautions, and important safety instructions in this section.
- Use your *Hardware Setup Guide* to set up and test your new printer.
- Have your network administrator refer to the *Administrator's Guide* to make network settings. Also see the *Administrator's Guide* for instructions on installing printer software.
- Attach the small box included in your printer package to the front of the printer. Keep the *Quick Reference Guide* in this box for help on understanding printer messages, clearing paper jams, and replacing the imaging cartridge.

See this *Reference Guide* for detailed information about your printer.

Proof Sign-off:  
M.Takata  
K.Nishi  
K.Pipa

\_\_\_\_\_  
\_\_\_\_\_  
\_\_\_\_\_

## **Flamingo Rev. C**

A5 size  
7/16/98

INTRO.FM  
Pass 0

R

---

### **About Your Printer**

Your printer is the latest in EPSON's advanced line of network laser printers. It emulates the Hewlett-Packard® LaserJet 4™ (LJ4) printer, allowing you to print using the wide variety of software programs that support HP LaserJet printers.

The printer's 600-dpi (dots per inch) resolution is enhanced by EPSON's Resolution Improvement Technology (RITech), which smooths the jagged edges of diagonal lines in both text and graphics. This gives your documents a clean, crisp look that contributes to a professional appearance.

In addition, EPSON's Enhance MicroGray technology provides you with better halftoning when printing graphics.

This printer is intended to be used on network environments. After network settings by your administrator, install the printer software as instructed by your administrator. "Administrator's Guide" is included in this printer package for your administrator.

The printer supports ECP mode in Microsoft® Windows® 95. ECP mode is useful for high-speed data transfer and bidirectional communication with your computer.

### **Features**

The printer comes with a full set of features that contributes to ease of use and consistent, high-quality output. The main features are described below.

#### **High-quality printing**

Your printer provides 600-dpi printing at a speed of up to 40 pages per minute. You'll appreciate the professional print quality produced by your printer and its quick processing speed.

Proof Sign-off:  
M.Takata  
K.Nishi  
K.Pipa

\_\_\_\_\_  
\_\_\_\_\_  
\_\_\_\_\_

## Flamingo Rev. C

A5 size  
7/16/98

INTRO.FM  
Pass 0

R

### Paper Sources

The Large Capacity Paper Unit (C81303\*), which includes lower paper cassettes 3, 4, and 5, allows you to preload up to 3550 sheets of paper in combination with the standard paper sources.

MP (Multi Purpose) Tray (standard)	50
Lower Cassette 1 (standard)	500
Lower Cassette 2 (standard)	500
Lower Cassette 3 (option)	500
Lower Cassette 4 (option)	1000
Lower Cassette 5 (option)	1000
	<hr/>
	3550

The (C81307\*) prints on various sizes of envelopes. This option is not compatible with the MP Tray.

### Duplex Unit

The Duplex Unit (C81304\*) prints on both sides of paper.

### Output trays

The Multibin Unit (C81305\*) can be used as a sorter, a mail box, or a large capacity stacker. This 10-bin unit accommodates up to 1000 printed sheets in total.

The Face-up Tray (C81306\*) holds up to 200 printed sheets with the printed side up.

When used in combination with the standard face-down tray, these options can handle up to 1700 printed sheets.

Face-down Tray (standard)	500
Face-up Tray (option)	200
Multibin Unit (option)	1000
	<hr/>
	1700



Proof Sign-off:  
M.Takata  
K.Nishi  
K.Pipa

\_\_\_\_\_  
\_\_\_\_\_  
\_\_\_\_\_

## **Flamingo Rev. C**

A5 size  
7/16/98

INTRO.FM  
Pass 0

R

### **Printer Driver**

Use the printer driver to easily and conveniently make new printer settings. Most users may never need to use anything other than their application software and the printer driver to make printer settings. You can access the printer driver through an application's Print command, or by choosing your printer in your operating system's Printers folder or program group. Be aware that settings you make in your application software override printer driver settings. See the driver's online help for more information.

### **OneTouch modes**

Use the OneTouch modes on the printer control panel to make printer settings when you cannot make a setting in your application software. The OneTouch modes are the easiest way to make several basic settings from the printer's control panel; however, your software application and printer driver in some cases override these settings. See "Using the OneTouch Modes" on page 2-7 for more information.

### **SelectType**

Use the SelectType buttons on the printer's control panel to make printer settings when you cannot make a setting in your application software. SelectType has more detailed options than the OneTouch modes but it may take a few extra steps to make those settings. See "Using SelectType" on page 4-2 for more information.

Proof Sign-off:  
M.Takata  
K.Nishi  
K.Pipa

\_\_\_\_\_  
\_\_\_\_\_  
\_\_\_\_\_

## Flamingo Rev. C

A5 size  
7/16/98

INTRO.FM  
Pass 0

R

### CDRH regulations

The Center for Devices and Radiological Health (CDRH) of the U.S. Food and Drug Administration implemented regulations for laser products on August 2, 1976. Compliance is mandatory for products marketed in the United States. The label shown below indicates compliance with the CDRH regulations and must be attached to laser products marketed in the United States.

This laser product conforms to the applicable requirement of 21 CFR Chapter I, subchapter J.  
SEIKO EPSON CORP.  
Hirooka Office  
80 Hirooka, Shiojiri-shi, Nagano-ken,  
Japan  
MANUFACTURED:

### Laser safety labels



**Warning:**

*Use of controls, adjustments, or performance of procedures other than those specified in this guide may result in hazardous radiation exposure.*

Your printer is a Class 1 laser product as defined in IEC 825 specifications. The label shown below is attached in countries where required.

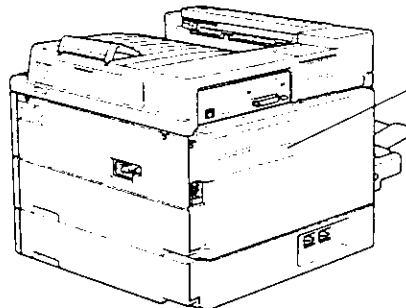

LASER KLASSE 1 NACH IEC 825  
CLASS 1 LASER PRODUCT TO IEC 825  
KLASSE 1 LASER PRODUKT I.H.T. IEC 825  
LUOKAN 1 LASERLÄITE

Proof Sign-off:  
M.Takata  
K.Nishi  
K.Pipa

\_\_\_\_\_  
\_\_\_\_\_  
\_\_\_\_\_

## Flamingo Rev. C

A5 size  
7/16/98

INTRO.FM  
Pass 0

R

---

### Laser Printer Precautions

This printer uses laser technology. The following list of precautions applies whenever you open the printer cover. Even if you are familiar with other types of printers, be sure to follow these precautions carefully to ensure safe, efficient operation.

- Do not touch the areas specified on the caution labels inside cover A. If the printer has been in use, these areas can be very hot.

CAUTION  
Hot Surface Avoid Contact

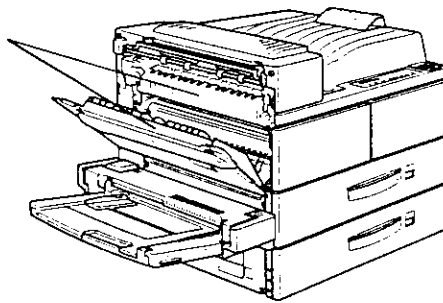

- Avoid touching the components inside the printer unless instructed to do so in this guide.
- Never force the printer's components into place. Although the printer is designed to be sturdy, rough handling can damage it.
- Be sure not to scratch the surface of the drum. When you remove the imaging cartridge from the printer, always set the unit on a clean, smooth surface. Also, avoid touching the drum, since oils from your skin can permanently damage its surface and may affect print quality.
- Do not turn the cartridge upside down or stand it on its sides.

To get the best print quality, do not store the imaging cartridge in an area subject to direct sunlight, dust, salty air, or corrosive gasses (such as ammonia). Avoid locations subject to high temperatures, humidity, or abrupt changes in temperature or humidity. Also, be sure to keep the consumable components out of the reach of children.

**Hinweis:**

*Die Geräteanschlußleitung muß den einschlägigen Normen genügen. Es muß eine dreiadrige Leitung verwendet werden. Die Anschlußleitung darf nicht leichter als H05VV-F oder H05VVH2-F sein.*

*Maschinenlärminformations-Verordnung-3. GSGV, 18. 01. 1991: Der arbeitsplatzbezogene schalldruckpegel beträgt 70 dB (A) oder weniger gemäß ISO 7779.*

---

### **Important Safety Instructions**

Read all of these instructions before operating your printer.

- Follow all warnings and instructions marked on the printer.
- Unplug the printer from the wall outlet before cleaning.
- Use a damp cloth for cleaning and do not use liquid or aerosol cleaners.
- Do not use this printer near water.
- Do not place the printer on an unstable cart, stand, or table.
- Slots and openings in the cabinet and the back or bottom are provided for ventilation. Do not block or cover them. Do not put the printer on a bed, sofa, rug, or other similar surfaces or in an enclosure unless proper ventilation is provided.

Proof Sign-off:  
M.Takata  
K.Nishi  
K.Pipa

\_\_\_\_\_  
\_\_\_\_\_  
\_\_\_\_\_

## Flamingo Rev. C

A5 size  
7/16/98

INTRO.FM  
Pass 0

R

- E. If it exhibits a distinct change in performance, indicating a need for service.
- F. When the power cord or plug is damaged or frayed.

---

### For United Kingdom Users

#### Use of options

EPSON (UK) Limited shall not be liable against any damages or problems arising from the use of any options or consumable products other than those designated as Original EPSON Products or EPSON Approved Products by EPSON (UK) Limited.

#### Safety information

**Warning:** This appliance must be earthed. Refer to rating plate for voltage and check that the appliance voltage corresponds to the supply voltage.

**Important:** The wires in the mains lead fitted to this appliance are coloured in accordance with the following code:

Green and yellow—Earth  
Blue—Neutral  
Brown—Live

**If you need to fit a plug:**

As the colours of the mains lead of this appliance may not match any coloured markings used to identify the terminals in a plug, please proceed as follows:

- The green and yellow wire must be connected to the terminal in the plug which is marked with the letter E or the Earth symbol ( $\perp$ ).

Proof Sign-off:  
M.Takata  
K.Nishi  
K.Pipa

\_\_\_\_\_  
\_\_\_\_\_  
\_\_\_\_\_

**Flamingo**  
**Rev. C**

A5 size  
7/16/98

LOADING.FM  
Pass 0

R

*Chapter 1*

**Printing with the EPL-N4000**

1

Precaution for printing .....	1-2
Choosing Paper .....	1-2
Labels .....	1-3
Envelopes .....	1-3
Colored paper .....	1-3
Transparencies .....	1-3
Printing Operation .....	1-4
Loading paper in the MP (Multi Purpose) Tray .....	1-4
Loading paper in the lower cassettes .....	1-6
Selecting the paper size .....	1-10
Special Printing Operations .....	1-10
Loading an uncommon paper size .....	1-10
Printing one sheet at a time .....	1-11
Offset stacking mode .....	1-12

Proof Sign-off:  
M.Takata  
K.Nishi  
K.Pipa

\_\_\_\_\_  
\_\_\_\_\_  
\_\_\_\_\_

## **Flamingo Rev. C**

A5 size  
7/16/98

LOADING.FM  
Pass 0

R

### **Labels**

1

Use only labels designed for laser printers or plain-paper copiers. Use the MP Tray and lower cassettes to print on these materials.

To prevent the adhesive from coming in contact with printer parts, always use labels that completely cover the backing sheet so that no gaps occur between the individual labels.

Test the label sheet for leaking adhesive by pressing a sheet of paper on top of a sheet of labels. If the paper sticks to the label sheet when you lift it off, do not use the labels.

### **Envelopes**

Printing quality on envelopes may be irregular because different parts of an envelope have different thicknesses. If the printing is too light, adjust the print density in the printer driver or the printer's control panel.

#### **Note:**

*Because thickness and surface characteristics are especially important for envelopes, test a sample for print quality and proper feeding before you buy a large number of envelopes.*

### **Colored paper**

You can use colored paper as long as it meets the weight limits shown in the paper specifications. Do not, however, use coated paper (paper to which a clear or colored coating has been added).

### **Transparencies**

You can use overhead projector transparencies and adhesive drafting film if they are made for use with plain-paper copiers or laser printers. Load these media into a lower cassette or the MP Tray.



To load paper in the MP Tray, follow the steps below.

1. Open the MP Tray if it is closed against the body of the printer. Pull out the extension if necessary.

1

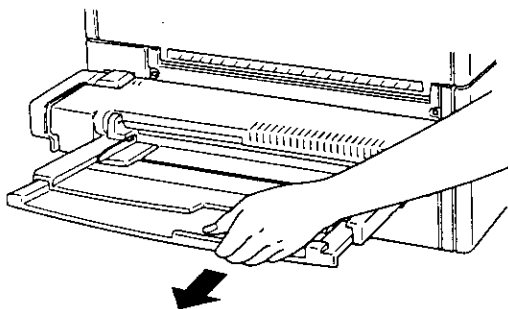

2. Fan a stack of paper and tap the edges of the stack on a flat surface to even the edges.
3. With the printable side down, load the stack by inserting it all the way into the tray. Make sure the paper lies below the arrows on the paper guide. Adjust the guide to match the size of your paper.

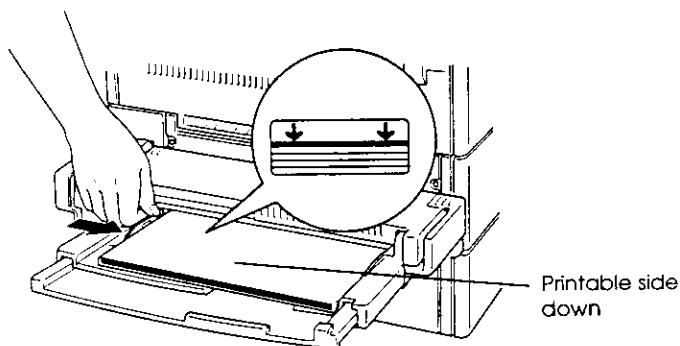



Proof Sign-off:  
M.Takata  
K.Nishi  
K.Pipa

\_\_\_\_\_  
\_\_\_\_\_  
\_\_\_\_\_

## Flamingo Rev. C

A5 size  
7/16/98

LOADING.FM  
Pass 0

R

To load paper in a lower cassette, follow the steps below.

1. Pull out the cassette that you want to load.

1

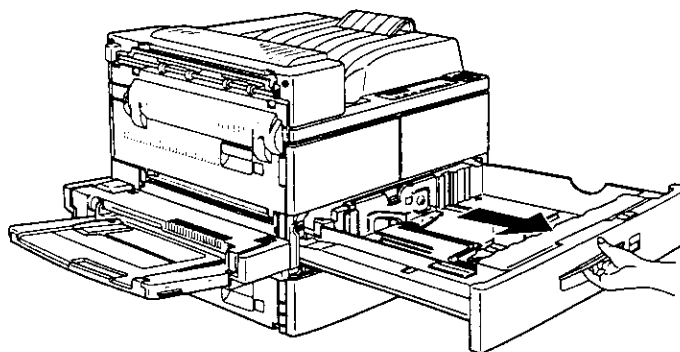

2. While pulling up the vertical paper guide, slide it outward as far as it will go.

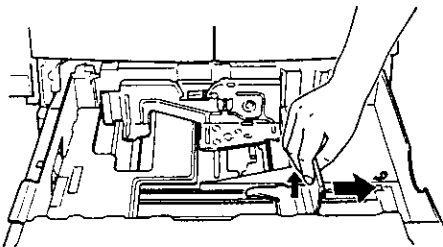

3. While pushing down the lever on the horizontal paper guide, slide it outward as far as it will go.

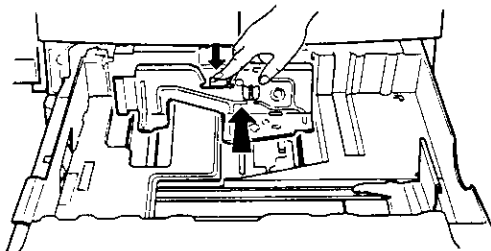

Proof Sign-off:  
M.Takata  
K.Nishi  
K.Pipa



## Flamingo Rev. C

A5 size  
7/16/98

LOADING.FM  
Pass 0

R

6. Take out the card with paper sizes printed on it. Fold the card and insert it into the cassette to show the paper size that you loaded.

1

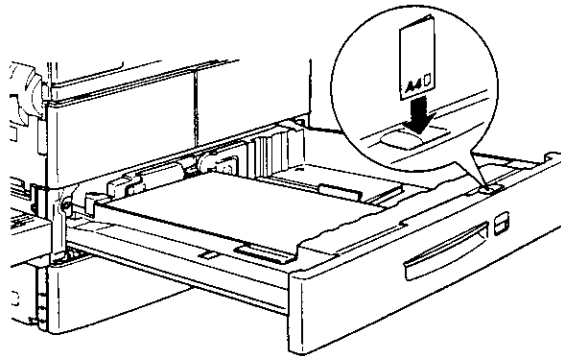

7. Push the cassette back into the printer.

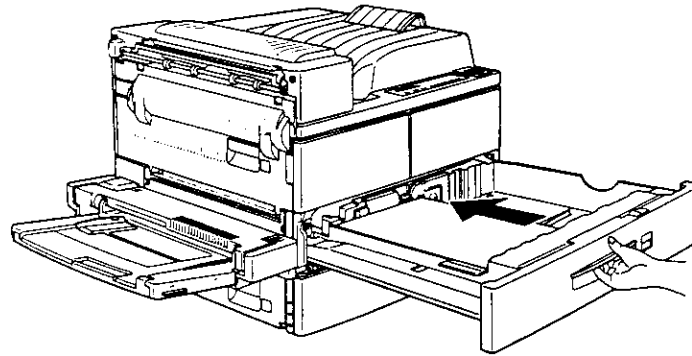

### **Printing one sheet at a time**

1

You can print one sheet at a time in the Manual Feed mode. This mode is helpful when you want to check the print quality after each page is printed.

To print in the manual feed mode, follow the steps below.

1. Access the printer driver.

**Note:**

*If you have not installed the printer driver, install it as instructed by your administrator. The "Administrator's Guide" is included in this printer package for your administrator.*

2. In the Basic Settings menu, select the Manual Feed check box.
3. In the Paper box, scroll through the list of paper sizes and click the size that matches the paper you will load in the printer.
4. Insert a sheet or stack of the correct size paper into the desired paper source. Adjust the paper guides to match the paper size you are loading.
5. Send a print job from your application. The control panel display shows Manual Feed and the selected page size.
6. Press On Line on your printer to print. The sheet of paper is fed and printed.
7. Press On Line again to print the next page of print data, if necessary. Repeat this step for every page to be printed.

Proof Sign-off:  
M.Takata  
K.Nishi  
K.Pipa

\_\_\_\_\_  
\_\_\_\_\_  
\_\_\_\_\_

**Flamingo**  
**Rev. C**

A5 size  
7/16/98

CONPANE.FM  
Pass 0

R

## Chapter 2

### **Control Panel**

The Control Panel .....	2-2
Overview .....	2-2
Display .....	2-2
Indicator lights .....	2-3
Buttons .....	2-4
Using the OneTouch Modes .....	2-7
OneTouch mode 1 .....	2-7
OneTouch mode 2 .....	2-8
Making OneTouch settings .....	2-8

2



For solutions to error messages and maintenance information, see Chapter 5, "Troubleshooting and Maintenance". For more information on SelecType, see Chapter 4, "SelecType".

### Indicator lights

2

On Line	On when the printer is on line, indicating the printer can receive and print data. When the printer is off line, this light is off. The light flashes as the system switches between on-line and off-line status.
Form Feed	On when data is received and stored in the printer's buffer but not yet printed. Flashing indicates the printer is processing data. When no data remains in the printer buffer (the section of memory reserved for receiving data), this light is off.
Continue	Flashes when an error is detected or a maintenance procedure must be performed. At the same time, an error or maintenance message appears on the display.
OneTouch mode 1	On when the printer is in OneTouch mode 1. For details on the OneTouch modes, see "Using the OneTouch Modes" on page 2-7.

Paper Source   Page Size   Manual Feed   Orientation



SelectType  
(ALT)

Selects a OneTouch mode or SelectType mode. Press this button once to enter OneTouch mode 1. Press this button again to enter OneTouch mode 2. Press this button once more to enter SelectType mode. Pressing this button while in SelectType mode returns the printer to on-line status. See Chapter 4, "SelectType" for more information.

2

ALT +  
Menu,  
Item,  
Value, or  
Enter

Advances the parameter or setting shown to the next value in each group. If used in combination with the ALT button in SelectType mode, it returns the shown parameter or setting to its previous value.

Menu

Selects the corresponding OneTouch mode setting listed above this button if in OneTouch mode 1 or 2, or selects the SelectType menu if in SelectType mode. Press this button when the printer is on line to enter SelectType mode.

Item

Selects the corresponding OneTouch mode setting listed above this button if in OneTouch mode 1 or 2, or selects the function available within the current menu after entering the SelectType mode.

Value

Selects the corresponding OneTouch mode option listed above this button if in OneTouch mode 1 or 2, or selects the parameter available within the current item, after entering the SelectType mode menu.

Proof Sign-off:  
M.Takata  
K.Nishi  
K.Pipa

\_\_\_\_\_  
\_\_\_\_\_  
\_\_\_\_\_

**Flamingo**  
**Rev. C**

A5 size  
7/16/98

CONPANE.FM  
Pass 0

R

---

## ***Using the OneTouch Modes***

The OneTouch modes are part of SelecType mode, but they are more limited and easier to use. The settings you make in these modes and SelecType are reflected in each other.

2

### ***OneTouch mode 1***

To enter OneTouch mode 1, press the SelecType button (repeatedly if necessary) until the light next to Paper Source comes on, indicating the printer is now in OneTouch mode 1. The current OneTouch mode 1 settings for Paper Source, Page Size, Manual Feed, and Orientation are shown on the display in this order.

#### ***Paper Source***

Specifies whether paper feeds into the printer from the MP Tray, the optional envelope feeder, a standard lower paper cassette, or from an optional lower paper cassette (if installed). If you select Auto, the paper source containing the paper that matches the setting in the Page Size menu will be used.

#### ***Page Size***

Specifies the paper size.

#### ***Manual Feed***

Turns Manual Feed on or off. For details on the Manual Feed mode, see "Printing one sheet at a time" on page 1-11.

#### ***Orientation***

Specifies whether the page is printed in portrait (Port) or landscape (Land) orientation.

Proof Sign-off:  
M.Takata  
K.Nishi  
K.Pipa

\_\_\_\_\_  
\_\_\_\_\_  
\_\_\_\_\_

**Flamingo**  
**Rev. C**

A5 size  
7/16/98

OPTIONS.FM  
Pass 0

R

---

## Chapter 3

### Options

Printer Options .....	3-2
Installing and Removing Options .....	3-3
Large Capacity Paper Unit .....	3-3
Duplex Unit .....	3-10
Face-up tray .....	3-16
Envelope feeder .....	3-28
Multibin Unit .....	3-32
Memory modules .....	3-47
ROM module .....	3-52
Optional interfaces .....	3-54
Using the Options .....	3-57
Large Capacity Paper Unit .....	3-57
Duplex Unit .....	3-58
Face-up tray .....	3-58
Envelope feeder .....	3-60
Multibin Unit .....	3-61

3





- The Envelope Feeder (C81307\*). Enables you to use the envelopes listed below. This option is not compatible with the MP Tray.

Monarch, Commercial 10, DL, C5

- Optional interface cards provide a link that enables you to use the EPL-N4000 with additional serial or parallel interface.
- Optional memory modules expand your printer's memory. See "Memory modules" on page 3-47.
- The Adobe PostScript 3 Kit (C83232\*) ROM module generates crisp PostScript output.

3

Before installing an option, read the sheet packed with the option as well as the installation instructions in this chapter.

---

## ***Installing and Removing Options***

To install an option to the EPL-N4000, follow the steps in this section. Instructions on removing the options are also included.

### ***Large Capacity Paper Unit***

This section describes how to install the Large Capacity Paper Unit.

#### ***Installing the Large Capacity Paper Unit***

##### *Before installing*

1. Turn off the printer.
2. Unplug the printer's power cord from the electrical outlet.
3. Remove all interface cables from the interface connectors.

Proof Sign-off:  
M.Takata  
K.Nishi  
K.Pipa



# Flamingo Rev. C

A5 size  
7/16/98

OPTIONS.FM  
Pass 0

R

2. Lock the casters at the bottom of the unit by pushing their levers down.

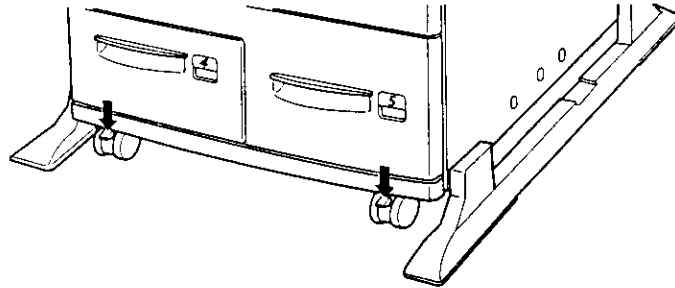

3

3. At the back of unit, push the power cord into the slot.

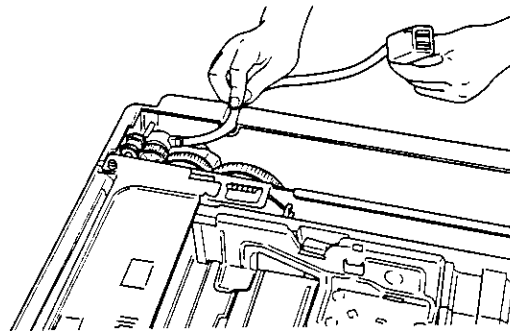

Proof Sign-off:  
M.Takata  
K.Nishi  
K.Pipa



## Flamingo Rev. C

A5 size  
7/16/98

OPTIONS.FM  
Pass 0

R

6. Make sure all corners of the printer fit firmly onto the unit.

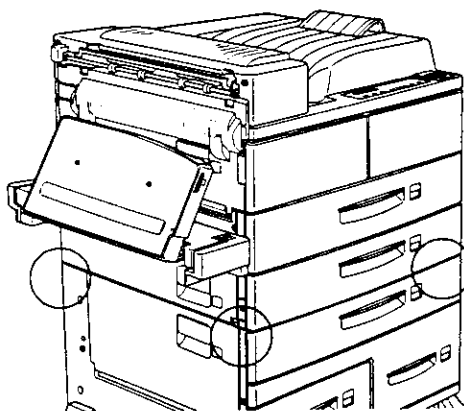

3

### After installing

1. Pull out lower cassette 2 as far as it will go. Then lift it up slightly, and completely remove it.

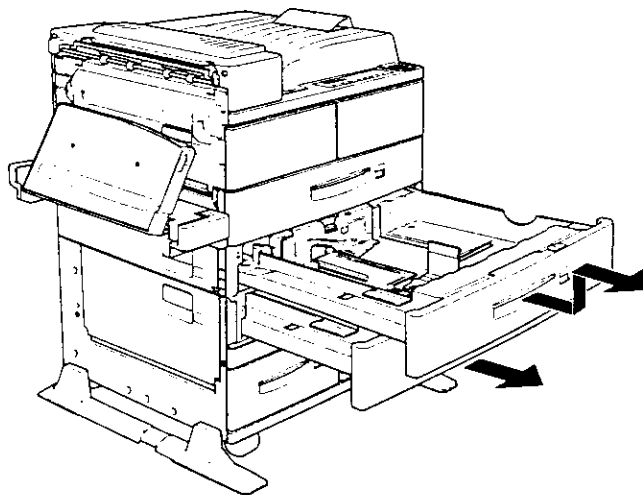

2. Pull out lower cassette 3 until you can see the two joints at both sides of the printer.

Proof Sign-off:  
M.Takata  
K.Nishi  
K.Pipa



## Flamingo Rev. C

A5 size  
7/16/98

OPTIONS.FM  
Pass 0

R

7. Pull out lower cassette 5 and remove the protective materials inside. Be sure to open the inside cover and remove the protective insert.

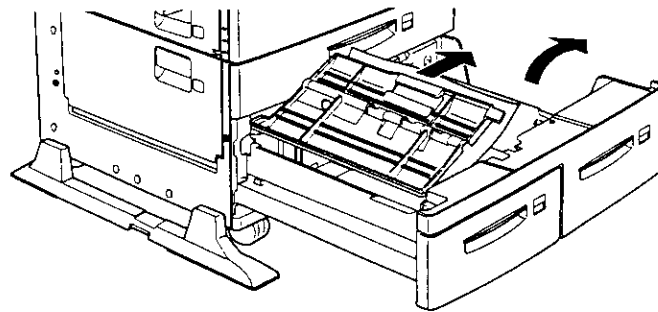

3

8. Plug the cord from the Large Capacity Paper Unit into the appropriate connector on the back of the printer.

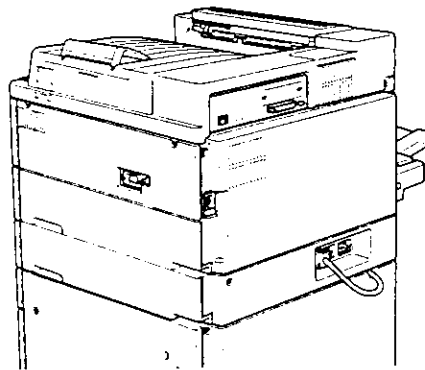

9. Reconnect any interface cables you removed.
10. Make sure the printer is turned off. Plug the printer's power cord into an electrical outlet.
11. Turn on the printer.

Proof Sign-off:  
M.Takata  
K.Nishi  
K.Pipa



# Flamingo Rev. C

A5 size  
7/16/98

OPTIONS.FM  
Pass 0

# R

2. Lower the Duplex Unit to insert the two matching hooks into the slots in the MP tray's holder. Attach the hooks to the corresponding mounting rods until you hear a click.

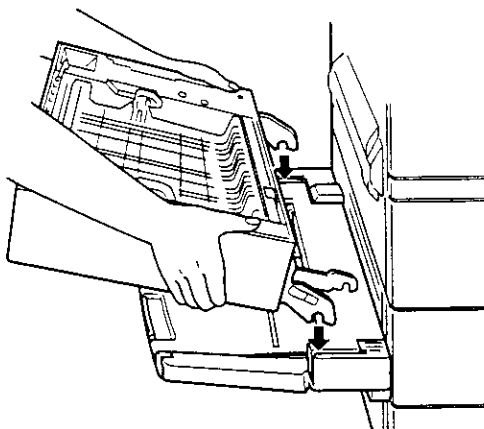

3

3. Attach the second hook on the right side to the other rod.

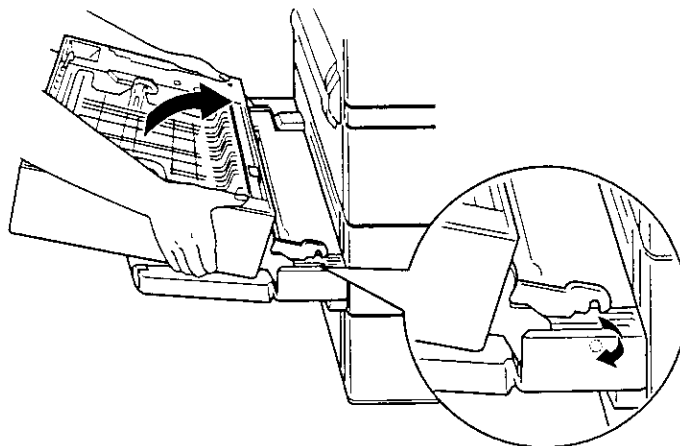

Proof Sign-off:  
M.Takata  
K.Nishi  
K.Pipa

\_\_\_\_\_  
\_\_\_\_\_  
\_\_\_\_\_

## Flamingo Rev. C

A5 size  
7/16/98

OPTIONS.FM  
Pass 0

R

6. After removing the protective cover from the cord, plug the cord of the Duplex Unit into the appropriate connector at the back of the printer.

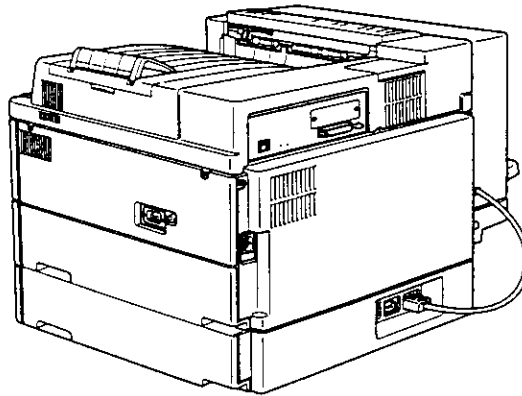

3

### *After installing*

1. Reconnect any interface cables you removed.
2. Make sure the printer is turned off. Plug the power cord into an electrical outlet.
3. Turn on the printer.

To confirm that the Duplex Unit is installed correctly, print a status sheet. If the unit is not listed on the status sheet, try reinstalling it.

### **Removing the Duplex Unit**

To remove the Duplex Unit, follow the instructions below.

### *Before removing*

1. Turn off the printer.
2. Unplug the printer's power cord from the electrical outlet.

Proof Sign-off:  
M.Takata  
K.Nishi  
K.Pipa

\_\_\_\_\_  
\_\_\_\_\_  
\_\_\_\_\_

# Flamingo Rev. C

A5 size  
7/16/98

OPTIONS.FM  
Pass 0

R

4. Unhook the hook at the end of the strap and fold it into the Duplex Unit.

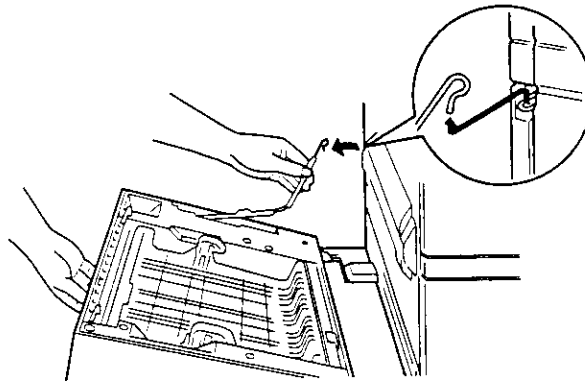

3

5. Unhook the upper right hook as shown below.

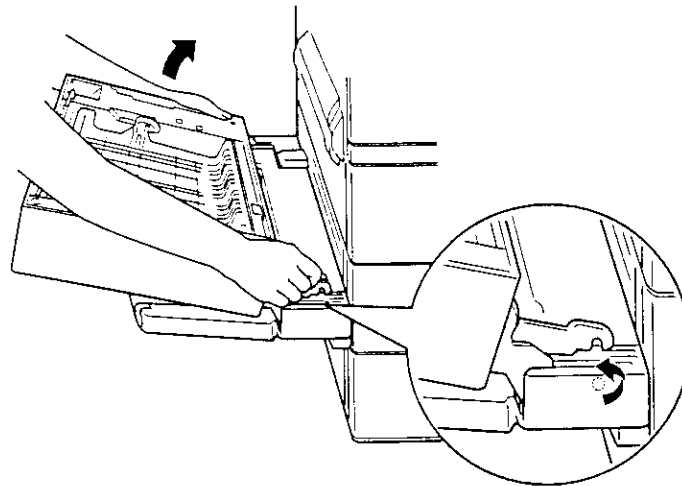

Proof Sign-off:  
M.Takata  
K.Nishi  
K.Pipa



**Flamingo**  
**Rev. C**

A5 size  
7/16/98

OPTIONS.FM  
Pass 0

R

3. Remove all interface cables from the interface connectors.
4. Unpack the face-up tray and remove all protective materials. Make sure the contents of the package match the items on the included sheet.

*Installing*

1. Attach the metal bar with the static barrier shown below to the printer.

3

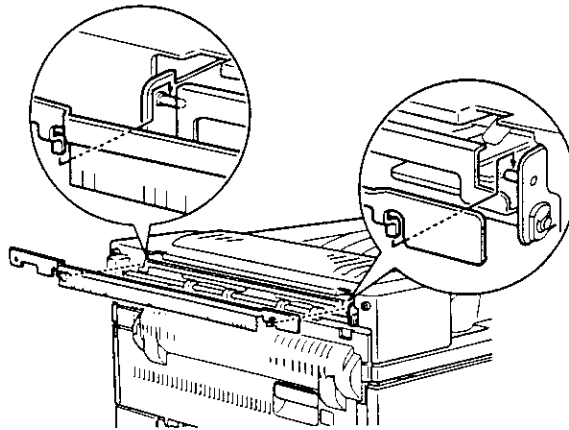



Proof Sign-off:  
M.Takata  
K.Nishi  
K.Pipa

\_\_\_\_\_  
\_\_\_\_\_  
\_\_\_\_\_

## Flamingo Rev. C

A5 size  
7/16/98

OPTIONS.FM  
Pass 0

R

4. Hook the top edge of the face-up tray around the metal bar to attach the tray to the printer.

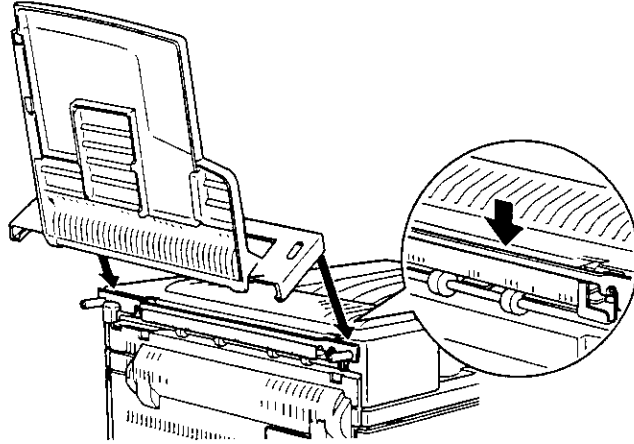

3

5. Lower the face-up tray.

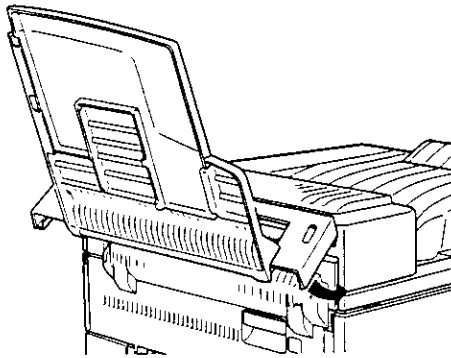

### *After installing*

1. Reconnect any interface cables you removed.
2. Make sure the printer is turned off. Plug the power cord into an electrical outlet.

Proof Sign-off:  
M.Takata  
K.Nishi  
K.Pipa



## Flamingo Rev. C

A5 size  
7/16/98

OPTIONS.FM  
Pass 0

R

4. Unpack the face-up tray and remove all protective materials. Make sure the contents of the package match the items on the included sheet.

### Installing

1. Push the plate on the optional Duplex Unit in six locations to detach it. Then remove the plate.

3

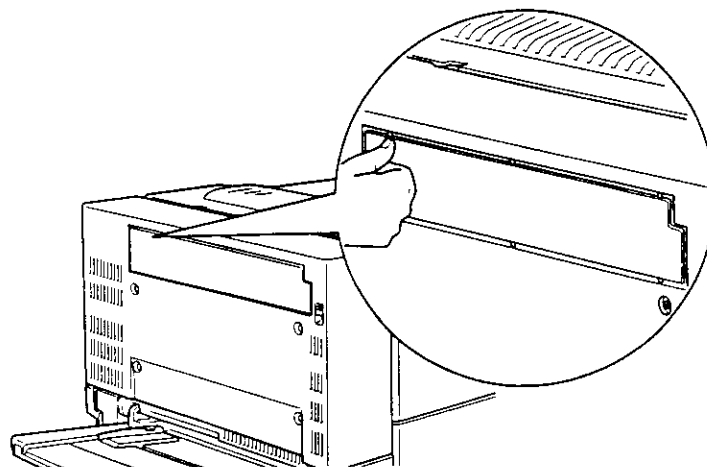



4. To attach the tray, hook the slots on both sides of the face-up tray to the corresponding pegs.

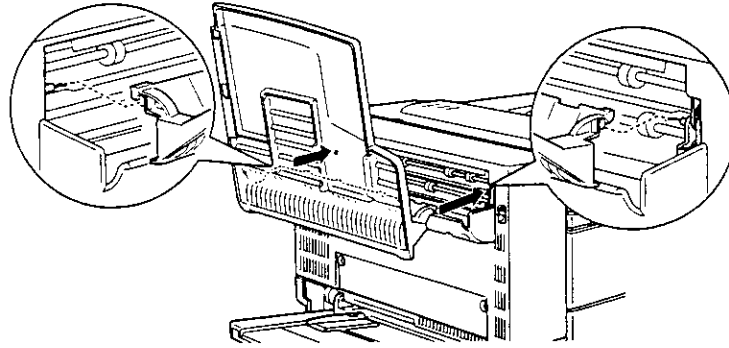

3

5. Lower the face-up tray.

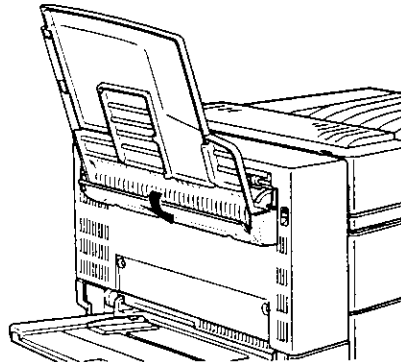

*After installing*

1. Reconnect any interface cables you removed.
2. Make sure the printer is turned off. Plug the power cord into an electrical outlet.
3. Turn on the printer.
4. On the control panel's Setup Menu, set Face-UP Enable to On. See "Using SelecType" on page 4-2.

Proof Sign-off:  
M.Takata  
K.Nishi  
K.Pipa



# Flamingo Rev. C

A5 size  
7/16/98

OPTIONS.FM  
Pass 0

# R

## Removing

1. Turn the face-up tray upward and lift it up.

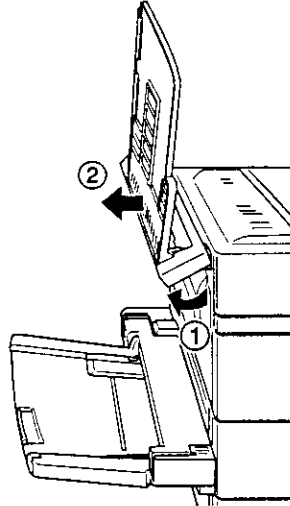

3

2. Loosen and remove the two screws as shown below.

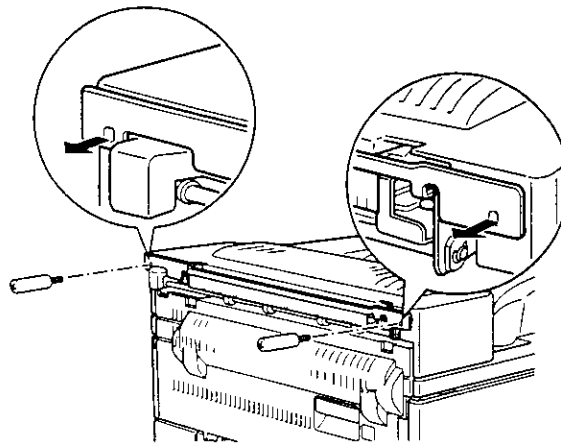

Proof Sign-off:  
M.Takata  
K.Nishi  
K.Pipa



# Flamingo Rev. C

A5 size  
7/16/98

OPTIONS.FM  
Pass 0

# R

## Removing

1. Turn the face-up tray upward and lift it up.

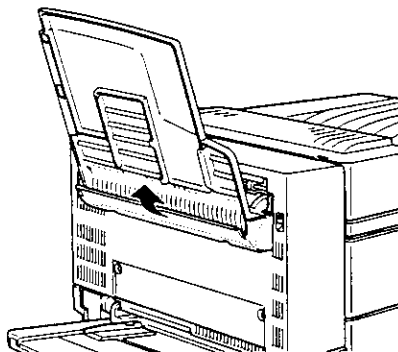

3

2. Detach the hook from the cover.

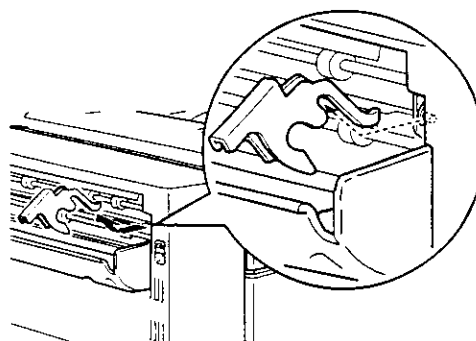



3. Remove all interface cables from the interface connectors.
4. Unpack the envelope feeder and remove all protective materials. Make sure the contents of the package match the items on the included sheet.

*Installing*

1. Remove the MP Tray by lifting it slightly and pulling it out toward you.

3

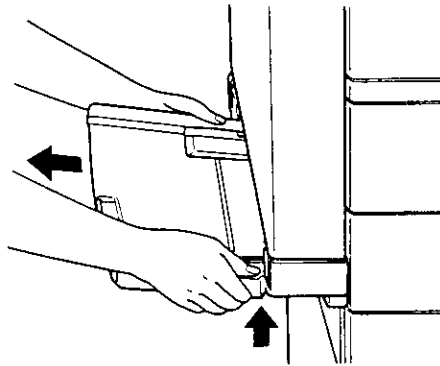

2. After unpacking the envelope feeder, hold it horizontally with both hands.
3. Push it straight, all the way into the printer, until it clicks.

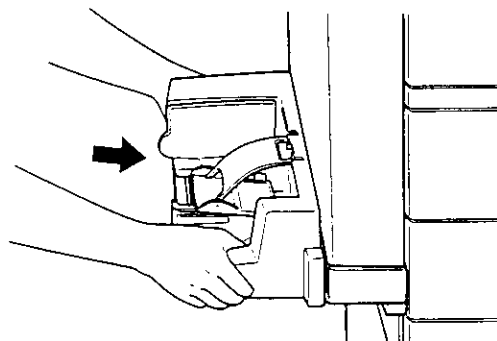



*Removing*

1. Slightly lift the envelope feeder and pull it out toward you.

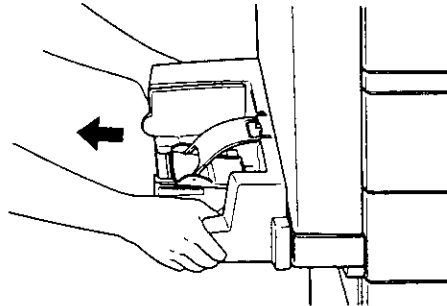

3

2. Push the MP Tray straight into the printer as far as it will go until it clicks.

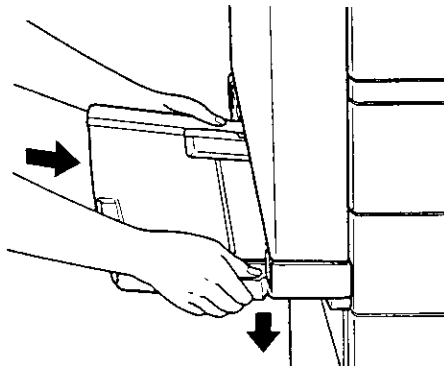

*After removing*

1. Reconnect any interface cables you removed.
2. Make sure the printer is turned off. Plug the power cord into the printer, then into an electrical outlet.
3. Turn on the printer.



2. Align the two pins on the bracket with the holes on the right side of the printer. Insert the pins into the Large Capacity Paper Unit, then lower the bracket until it is firmly attached.

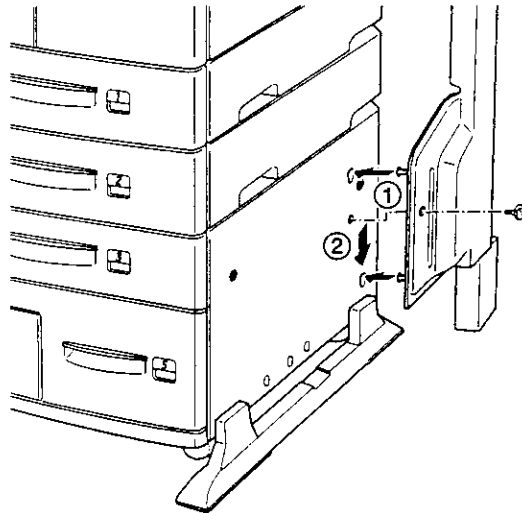

3. Insert one of the included screws shown above into the hole in the bracket and tighten.
4. Remove the protective cover from the remaining bracket, then repeat steps 2 and 3 to install the bracket to the left side of the printer.

*Installing the top bracket*

1. Remove the protective cover from the top bracket.



Proof Sign-off:  
M.Takata  
K.Nishi  
K.Pipa



## Flamingo Rev. C

A5 size  
7/16/98

OPTIONS.FM  
Pass 0

R

### Installing the Multibin Unit

1. Pull away the four clips from the box, then lift the box up.

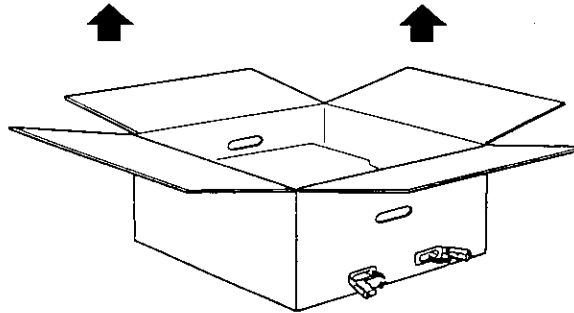

3

2. Lift the Multibin Unit out of the box and place it on the floor as shown below. Remove the protective material just before installing the unit to the printer.

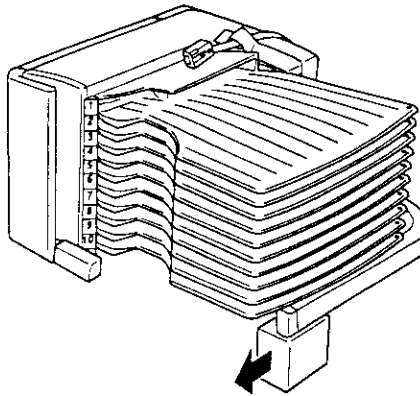

Proof Sign-off:  
M.Takata  
K.Nishi  
K.Pipa



## Flamingo Rev. C

A5 size  
7/16/98

OPTIONS.FM  
Pass 0

R

5. Lower the Multibin Unit until the plate on the Multibin Unit is slightly higher than the top of the pin on the top bracket.

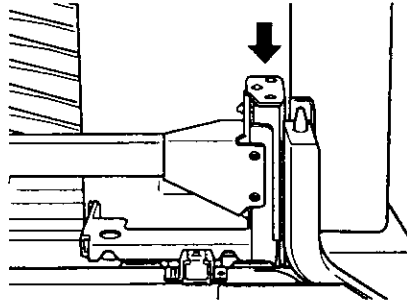

3

6. Push the Multibin Unit horizontally into the pole on the top bracket as shown below.

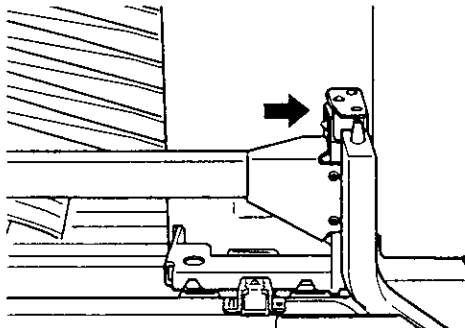



2. Open cover D and detach the grip from the inside. To detach the grip, push the button near the side of the grip, lower the grip a little, then pull it away from the Multibin Unit.

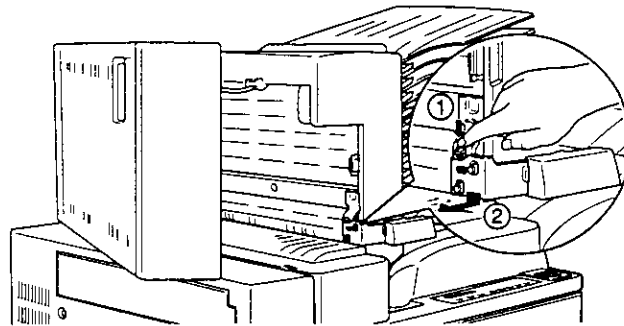

3

3. Attach the grip on the opposite side of Multibin Unit. To do this, align the handle's metal bracket with the slot in the side bracket, then insert the grip into the hollow on the side of Multibin Unit. Push in until it clicks.

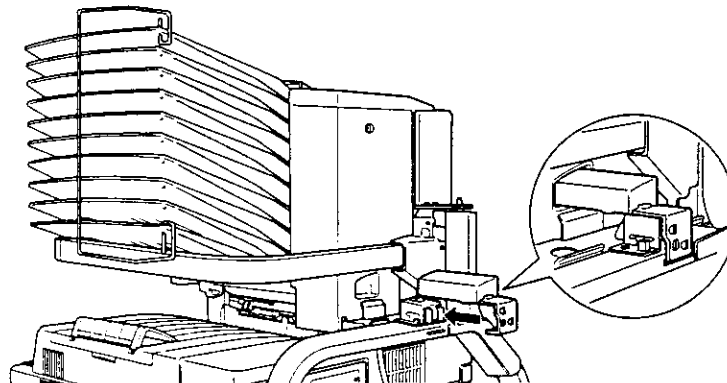

*Note:*  
*Make sure to lock the Multibin Unit as above.*

Proof Sign-off:  
M.Takata  
K.Nishi  
K.Pipa

\_\_\_\_\_  
\_\_\_\_\_  
\_\_\_\_\_

## Flamingo Rev. C

A5 size  
7/16/98

OPTIONS.FM  
Pass 0

R

3. Plug the cord of the Multibin Unit into the appropriate connector on the back of the printer.

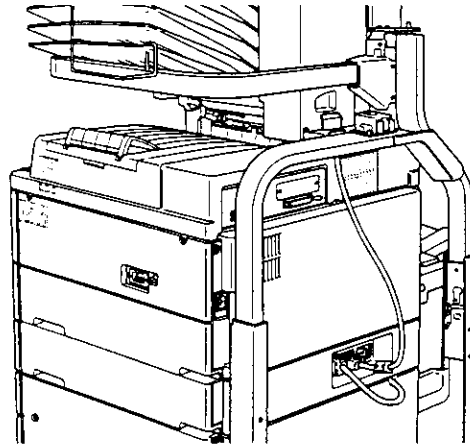

4. Reconnect any interface cables you removed.
5. Make sure the printer is turned off. Plug the power cord into an electrical outlet.
6. Turn on the printer.

To confirm that the Multibin Unit is installed correctly, print a status sheet by pushing the Enter button on the control panel two times while the printer is on line. If the unit is not listed on the status sheet, try reinstalling it.

### **Removing the Multibin Unit**

Follow the instructions below.

#### *Before removing*

1. Turn off the printer.
2. Unplug the printer's power cord from the electrical outlet.



### Unlocking the Multibin Unit

1. Detach the grip from the printer's back by pushing the button and pulling out the grip, as shown below.

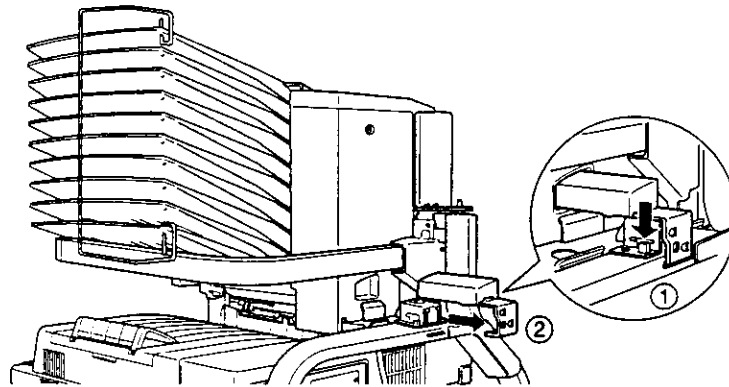

2. Push the tab of the lock down and pull it away from the unit until it unlocks.

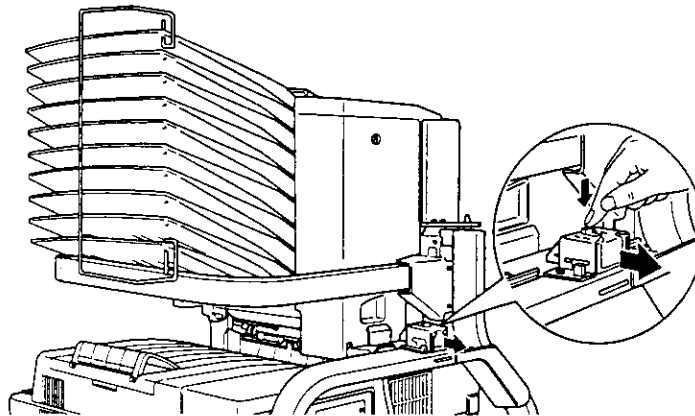

Proof Sign-off:  
M.Takata  
K.Nishi  
K.Pipa



# Flamingo Rev. C

A5 size  
7/16/98

OPTIONS.FM  
Pass 0

# R

- Lift the unit up, completely away from the pin on the top bracket.

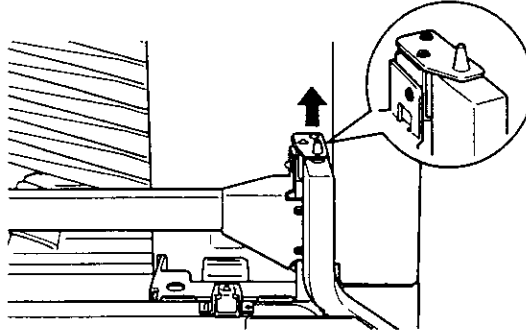

3

- Move the unit away from the pole on the side bracket.

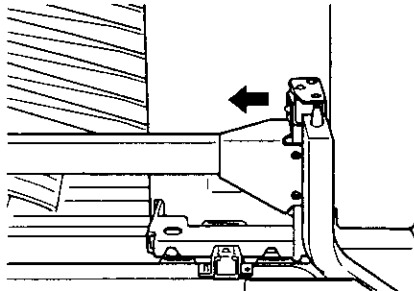



2. Make sure the printer is turned off. Plug the power cord into an electrical outlet.
3. Turn on the printer.

### **Memory modules**

By installing a memory module in both open slots, you can increase printer memory up to 256 MB. You may want to add memory if you are having difficulty printing complex, graphics-intensive pages, using the Multibin Unit with the double printing feature, or if you regularly use numerous downloaded fonts.

3

You can purchase memory modules from various vendors. Be sure the memory module you purchase meets the following requirements.

- Synchronous Dynamic RAM Double In-line Memory Module (SD RAM DIMM)
- 168-pin type, 64 bit, with SPD
- Capacity of 16, 32, 64, or 128 MB
- Access speed of 66.66 MHz or higher (15 ns or less)
- Height of less than 40 mm

### **Installing a memory module**

#### *Before installing*

1. Turn off the printer.



**Warning:**

*To avoid electrical shock, do not attempt to install a memory module unless the printer is turned off.*

2. Unplug the printer's power cord from the electrical outlet.



**Warning:**

*Avoid touching electrical components that are exposed after you remove the shield cover. They may be very hot if the printer has been in use.*

*Installing*

1. Slots for memory modules are located as shown below.

3

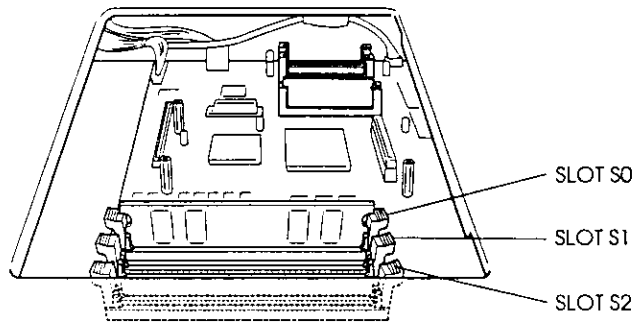

2. Pull the clips on each side of SLOT S1 outward.

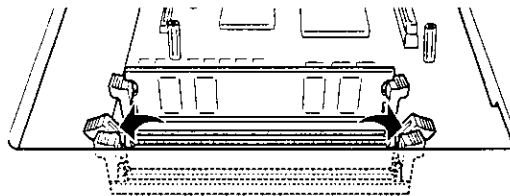





*After installing*

1. Replace the plate to its original position. Place the two outside tabs of the plate under the edge of the opening with the inside tabs on top of the edge.

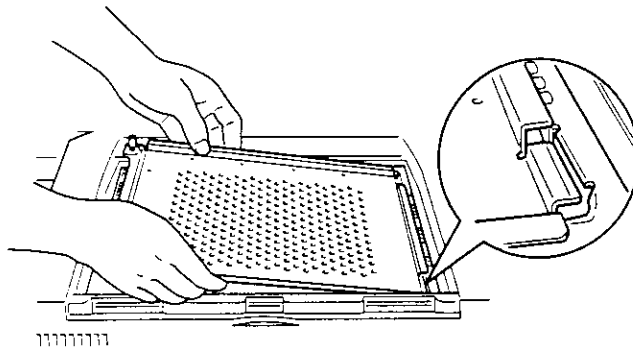

2. Push the plate down into place.

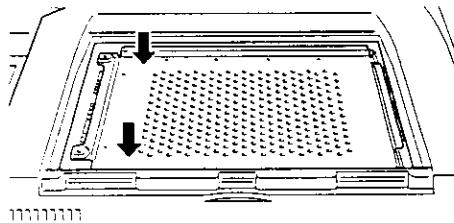

3. Tighten the two screws that you loosened earlier.
4. Gently replace the top cover until it clicks shut.

To confirm that the memory module is installed correctly, print a status sheet.

**Removing a memory module**

1. Follow the steps in "Before installing" on page 3-47 to access the memory slot.



2. Slots for ROM modules are located as shown below.

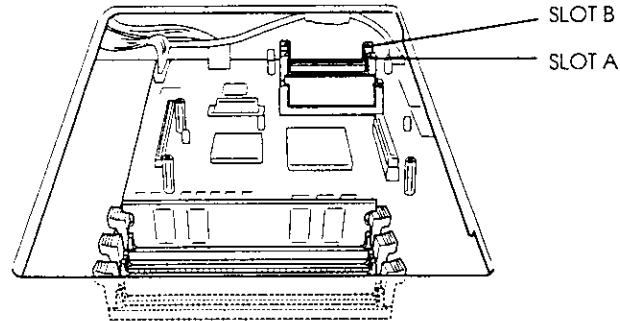

3

3. Hold the ROM module with the following orientation, then push the ROM module into SLOT A evenly until the button comes up.

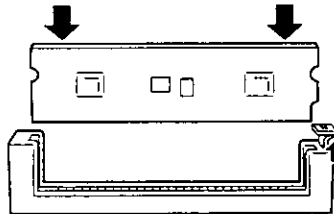

4. Follow steps 1 through 4 in "After installing" on page 3-51 to complete the procedure.

### **Removing the ROM module**

1. Follow steps 1 through 6 in "Before installing" on page 3-47.



The coax and twinax connectors each contain a parallel interface. Since the printer's built-in parallel interface remains active, this gives you two parallel interfaces and a coax or twinax interface. Print jobs can be sent to any connection, and the printer automatically switches between the active ports.

The twinax interface is compatible with the following IBM systems: AS-400, System 36, 5251 (model 12), System 34, System 38, and 5294. When equipped with the EPSON twinax interface, the printer can be used in place of the following IBM system printers: 4210, 5224 (models 1 and 2), 5256 (models 1, 2, and 3), 3218 (non IPDS), 4214 (model 2), 5225 (models 1, 2, 3, and 4), and 5219 D01, D02.

3

The coax interface allows the printer to be connected to the following IBM control units and mainframe systems: 3174, 3276, 4274, and 3270.

- To add a direct connection to your GPIB network, use the GPIB Interface Card (C82313\*).

### ***Installing a Type-B interface card***

Follow the steps below to install an optional interface card.

#### *Before installing*

1. Turn off the printer.



**Warning:**

*To avoid electrical shock, do not attempt to install a card unless the printer is turned off.*

2. Unplug the printer's power cord from the electrical outlet.

#### *Installing*

1. Turn the printer so its back faces you.

---

## **Using the Options**

After installing the options, read the usage instructions below. Make sure you select the option or options that you have installed in the printer driver's Option menu.

### **Large Capacity Paper Unit**

3

Be sure to select the paper source in your application program when printing to the Large Capacity Paper Unit. Since the selection method varies from application to application, see your software documentation for more information.



**Caution:**

*You cannot print on envelopes using the Large Capacity Paper Unit.*

### **Lower cassette 3**

Follow the loading instructions in "Loading paper in the lower cassettes" on page 1-6. Paper sizes and loading orientations match those for cassette 2.

### **Lower cassettes 4 and 5**

These cassettes can each store 1000 sheets and are helpful for storing paper you use often and in large amounts.

They accept the following paper sizes: A4, Letter, Executive.

Use the included stickers with paper sizes printed on them to identify the paper size being used in each cassette.

Proof Sign-off:  
M.Takata  
K.Nishi  
K.Pipa



## Flamingo Rev. C

A5 size  
7/16/98

OPTIONS.FM  
Pass 0

R

When you use the face-up tray with the Duplex Unit installed, you can open the DM cover without detaching the face-up tray. The tray remains angled to hold printed sheets.

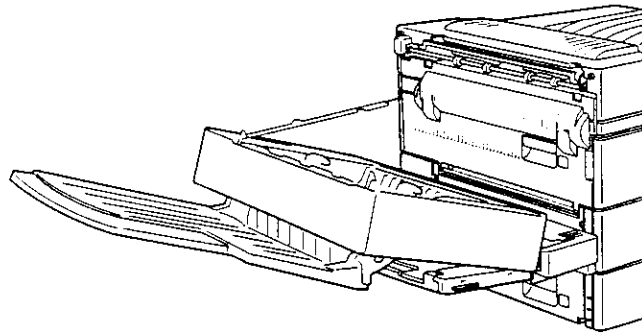

3

When you use the face-up tray without the Duplex Unit installed, temporarily remove the face-up tray before replacing the imaging cartridge or clearing a paper jam.

To temporarily remove the face-up tray, tilt it upward and lift up.

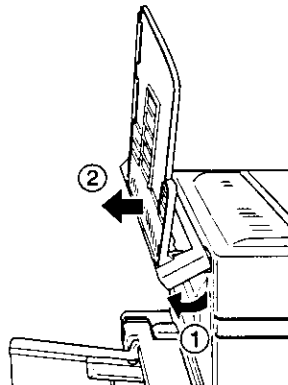



## Multibin Unit

This optional output unit with 10 bins, each with a capacity of 100 sheets, can be used in three ways; as a mailbox, a sorter, or a large capacity stacker. Consult your administrator to set the output mode of the unit.

**Note:**

- Changing the output mode too frequently could cause confusion and should be avoided.*
- Before changing the output mode, always consult your printer's administrator and inform all other users of the changes.*
- Select the output mode in the printer driver.*

3

### Using the mailbox feature

The mailbox mode allows each bin to be assigned to an individual or department.

When in the mailbox mode, if bin 1 (the first bin from the top) is assigned to you, you always need to select bin 1 as your output tray in the printer driver when sending a job to this printer.

Make sure all users know who uses which bin. To avoid confusion, write the name of each user next to the corresponding bin on the numbered strip. Open the clear plastic cover to access the numbered strip.

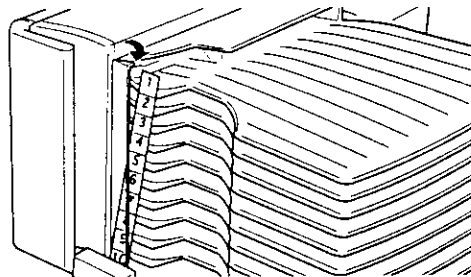

Proof Sign-off:  
M.Takata \_\_\_\_\_  
K.Nishi \_\_\_\_\_  
K.Pipa \_\_\_\_\_

**Flamingo**  
**Rev. C**

A5 size  
7/16/98

SELEC.FM  
Pass 0

R

---

## Chapter 4

---

### **SelectType**

When to Use SelectType .....	4-2
Using SelectType .....	4-2
SelectType Menus .....	4-3
SelectType Settings .....	4-6
Test Menu .....	4-6
Emulation Menu .....	4-7
Printing Menu .....	4-8
Tray Size Menu .....	4-11
Config Menu .....	4-12
Setup Menu .....	4-15
Parallel Menu .....	4-17
Network Menu .....	4-18
AUX Menu .....	4-19
LJ4 Menu .....	4-20
GL2 menu .....	4-21
PS3 menu .....	4-23
ESCP2 and FX menus .....	4-24
I239X menu .....	4-27

4



1. To enter SelecType mode, press Menu.
2. To change the settings, press Menu, Item, or Value.
  - To select a new menu (menu category), press Menu.
  - To select an item (setting) in a menu, press Item.
  - To select a value (parameter) for an item, press Value.
  - To activate a new setting, press Enter. An asterisk (\*) appears.
  - Press ALT to select a menu, item, or value in reverse order. See Appendix E, "Map of SelecType Menus" for a map showing the order that SelecType menus are displayed.
3. To exit SelecType mode, press On Line or SelecType.

## **SelecType Menus**

This section gives a brief description of the menus in SelecType and lists the settings available on each menu. For more detailed descriptions of the settings, see "SelecType Settings" on page 4-6.

<b>Menu</b>	<b>Items</b>
Test Menu	Status Sheet, LJ4 Font Sample, ESCP2 Font Sample, FX Font Sample, I239X Font Sample, PS3 Status Sheet*, PS3 Font Sample*, Network Status Sheet
Emulation Menu	Parallel, Network, AUX*
Printing Menu	Paper Source, Page Size, Wide A4, Orientation, Out Bin*, Copies, Manual Feed, Resolution, Skip Blank Page, Duplex*, Binding*, Start Page*, Offset Stacking
Tray Size Menu	MP Tray Size, ENV Tray Size*, MP Type, LC1 Type, LC2 Type, LC3 Type*, LC4 Type*, LC5 Type*



Proof Sign-off:  
M.Takata  
K.Nishi  
K.Pipa

\_\_\_\_\_  
\_\_\_\_\_  
\_\_\_\_\_

## **Flamingo Rev. C**

A5 size  
7/16/98

SELEC.FM  
Pass 0

R

### *Printing Menu*

Most of these settings can be made during daily use with your printer driver software. Always check the software settings as they override the Printing Menu settings.

### *Tray Size Menu*

Tray size settings specify the paper size you load in the MP Tray and optional Envelope Feeder. Tray type settings are for selecting the paper type loaded in the MP Tray or lower paper cassettes 1 through 5 (lower cassettes 3, 4, and 5 are part of the optional Large Capacity Paper Unit.)

4

### *Config Menu*

This menu allows you to control certain printer operations such as the Toner Save feature, RITech, and density settings.

### *Setup Menu*

This menu allows you to customize various printer modes, select a control panel language, check the total pages printed to date, and check the toner counter.

### *Parallel Menu*

These settings control communication between the printer and the computer when using a parallel interface.

### *Network Menu*

This menu allows you to control the internal interface settings.

### *AUX Menu*

This menu allows you to control the optional interface settings.

### *LJ4 Menu*

These settings control the fonts and symbol sets when in LJ4 mode.



*Status Sheet, PS3 Status Sheet\**

Prints a sheet describing the current printer features. Use this option to check whether your printer is working correctly.

*LJ4 Font Sample, ESCP2 Font Sample, FX Font Sample, I239X Font Sample, PS3 Font Sample\**

Prints a sample of the fonts available for your selected printer emulation.

\*Available only when Adobe PostScript 3 Kit is installed.

*Network Status Sheet*

Prints parameters in the internal network settings.

4

**Emulation Menu**

Use this menu to select the printer emulation mode. You can specify different emulations for each interface; in other words, for each computer you connect. Since each emulation mode has its own specific options, make settings in the LJ4, ESCP2, FX, GL2, or I239X menus, as necessary. The options you can set are the same for every interface.

Item	Values
Parallel	Auto, LJ4, ESCP2, FX, I239X, PS3*, GL2
Network	Auto, LJ4, ESCP2, FX, I239X, PS3*, GL2
AUX	Auto, LJ4, ESCP2, FX, I239X, PS3*, GL2

\* Available only when the Adobe PostScript 3 Kit is installed.

Proof Sign-off:  
M.Takata  
K.Nishi  
K.Pipa

\_\_\_\_\_  
\_\_\_\_\_  
\_\_\_\_\_

## Flamingo Rev. C

A5 size  
7/16/98

SELEC.FM  
Pass 0

R

If you select AUTO, paper feeds from the paper source containing paper that matches your Page Size setting.

**Note:**

*You can also make this setting directly from OneTouch Mode 1.*

### Page Size

Specifies the paper size.

**Note:**

*You can also make this setting directly from OneTouch Mode 1.*

4

### Wide A4

Enables you to print 80 columns on A4 portrait sheet when you print from a DOS application. Selecting this setting changes the right and left margins from 4 mm to 3.4 mm.

### Orientation

Specifies whether the page is printed in portrait or landscape orientation. This page is printed in portrait orientation.

**Note:**

*You can also make this setting directly from OneTouch Mode 1.*

### Out Bin

Specifies the output destination if you have installed either the optional face-up tray or Multibin Unit.

### Copies

Designates the number of copies to be printed, up to 999.

**Note:**

*You can also make this setting directly from OneTouch Mode 2.*

Proof Sign-off:  
M.Takata  
K.Nishi  
K.Pipa

\_\_\_\_\_  
\_\_\_\_\_  
\_\_\_\_\_

## Flamingo Rev. C

A5 size  
7/16/98

SELEC.FM  
Pass 0

R

### Tray Size Menu

Use this menu to make the paper size and paper type settings for each paper source.

Item	Values
MP Tray Size	A4, A3, A5, B4, B5, LT, B HLT, LGL, GLT, GLG, EXE, F4, IB5
ENV Tray Size*	C5, DL, C10, MON
MP Type	Plain, Preprinted, Letterhead, Prepunched, Bond, Recycled, Color, Trnspncy, Labels
LC1 Type	Plain, Preprinted, Letterhead, Prepunched, Bond, Recycled, Color, Trnspncy, Labels
LC2 Type	Plain, Preprinted, Letterhead, Prepunched, Bond, Recycled, Color, Trnspncy, Labels
LC3 Type*	Plain, Preprinted, Letterhead, Prepunched, Bond, Recycled, Color, Trnspncy, Labels
LC4 Type*	Plain, Preprinted, Letterhead, Prepunched, Bond, Recycled, Color, Trnspncy, Labels
LC5 Type*	Plain, Preprinted, Letterhead, Prepunched, Bond, Recycled, Color, Trnspncy, Labels

4

\* These appear only when the corresponding option is installed.

#### MP Tray Size

Allows you to set the paper size for the MP Tray.

**Note:**

You can also make the MP Tray Size setting directly from OneTouch Mode 2.

#### Env Tray Size

Allows you to set the envelope size for the envelope feeder.

#### MP Type

Displays the paper type you are selecting for the MP Tray.

Proof Sign-off:  
M.Takata  
K.Nishi  
K.Pipa



## Flamingo Rev. C

A5 size  
7/16/98

SELEC.FM  
Pass 0

R

### Toner Save

Turns the Toner Save mode on or off. When turned on, the printer saves toner by substituting a gray shade for the black inside of characters. The characters are outlined in full black on the right and lower edges.

**Note:**

*You can also make Toner Save settings directly from OneTouch Mode 2.*

### Density

Adjusts the print density to make your printout lighter or darker.

4

**Note:**

*Increasing the print density increases toner consumption. If you select darker print, you may need to replace the imaging cartridge more often.*

### Top Offset

Makes fine adjustments to the vertical position of the printing on the page.



**Caution:**

*Be sure that the printed image does not exceed the edge of paper. Otherwise, you may damage the printer.*

### Left Offset

Makes fine adjustments to the horizontal position of the printing on the page. This is useful for fine adjustment when you are using the manual feed mode.



**Caution:**

*Be sure that the printed image does not exceed the edge of paper. Otherwise, you may damage the printer.*

Proof Sign-off:  
M.Takata  
K.Nishi  
K.Pipa

\_\_\_\_\_  
\_\_\_\_\_  
\_\_\_\_\_

## Flamingo Rev. C

A5 size  
7/16/98

SELEC.FM  
Pass 0

R

### Note:

Changing the Page Protect setting reconfigures the printer's memory which causes any downloaded fonts to be erased.

### Image Optimum

Reduces the amount of graphics data when the data reaches the memory limit, allowing complex documents to be printed. When this mode is on, the quality of graphics is reduced.

### Setup Menu

4

Item	Values
Interface	Auto, Parallel, Network, AUX*
Time Out	0, 5 ... 60 ... 300 seconds in 1 increments
Standby	Enable, Disable
Lang	English, Français, Deutsch, ITALIANO, ESPANOL, SVENSKA, DANSK, Nederl., SUOMI, Português
Toner	E****F
Face-up Enable	Off, On
Multibin*	Mailbox, Stacker
Page Count	0 to 99999999
SelecType Init	-

\* These appear only when the corresponding option is installed.

### Interface

Specifies whether the printer can receive data through all the interfaces available or only through the one selected.

### Multibin

Selects the setting for the optional Multibin Unit. If you want to use alternate settings for the Multibin Unit, always consult your printer's administrator and inform all other users of the changes to avoid confusion. We recommend not changing these settings often.

**Note:**

- After changing this setting, reboot the printer to make the new settings effective. To reboot the printer, press the Continue and SelectType buttons simultaneously. Alternatively, turn off the printer, then after 5 seconds, turn it back on.*
- Rebooting the printer erases all print jobs. Make sure the On Line light is not blinking when you reboot the printer.*

4

### Page Count

Displays the total number of sheets printed by this printer.

### SelectType Init.

Erases all the SelectType settings you have changed, and resets them to the default settings.

### Parallel Menu

Item	Values
Speed	Fast, Normal
Bi-D	Nibble, ECP, Off

### Speed

Specifies the pulse width of the ACKNLG signal on receiving data in the Compatibility mode or Nibble mode. When this option is set to Fast, the pulse width is about 10 ms. When this option is set to Normal, the pulse width is about 1 ms.

Proof Sign-off:  
M.Takata  
K.Nishi  
K.Pipa

\_\_\_\_\_  
\_\_\_\_\_  
\_\_\_\_\_

## Flamingo Rev. C

A5 size  
7/16/98

SELEC.FM  
Pass 0

R

SM Byte 4	0 to 255
GW Byte 1	0 to 255
GW Byte 2	0 to 255
GW Byte 3	0 to 255
GW Byte 4	0 to 255
Buffer Size	Normal, Maximum, Minimum

### Note:

- After changing these settings, reboot the printer to make the new settings effective. To reboot the printer, press the Continue and SelectType buttons simultaneously. Alternatively, turn off the printer, then after 5 seconds, turn it back on.
- Rebooting the printer erases all print jobs. Make sure the On Line light is not blinking when you reboot the printer.

4

## AUX Menu

Item	Values
Buffer Size*	Normal, Maximum, Minimum

### Buffer Size

Determines the amount of memory to be used for receiving data and printing data. If set to Maximum, more memory is allocated for receiving data. If set to Minimum, more memory is allocated for printing data. The default setting is Normal.



### *Height*

Specifies the default font height if the font is scalable and proportional. You can select from 4.00 to 999.75 points, in increments of 0.25 points.

### *SymSet*

Selects the default symbol set. If the font you selected in Font Source and Font Number is not available in the new SymSet setting, the Font Source and the Font Number values are automatically replaced with the default value.

### *Form*

Selects the number of lines for the selected paper size and orientation. This also causes a line spacing (VMI) change, and the new VMI value is stored in the printer. This means that later changes in the Page Size or the Orientation settings cause changes in the Form value, based on the stored VMI.

### *Source SymSet*

Available only when an optional font ROM is installed.

### *Dest SymSet*

Available only when an optional font ROM is installed.

## **GL2 menu**

The EPSON GL/2 mode emulates a plotter, allowing you to use software which requires a plotter for output. The (LJ4GL2) mode is similar to the GL/2 mode supported in HP LaserJet 4 mode. The EPSON GL/2 mode emulates some of the HP-GL plotter commands and includes all the commands found in HP's GL/2 mode, as well as two additional commands.

Item	Values
GL-Mode	GLlike, LJ4GL2

Proof Sign-off:  
M.Takata  
K.Nishi  
K.Pipa

\_\_\_\_\_  
\_\_\_\_\_  
\_\_\_\_\_

## Flamingo Rev. C

A5 size  
7/16/98

SELEC.FM  
Pass 0

R

### Join

Specifies the way in which lines are joined.

### Pens 0 through 6

Allows you to set the thickness of the "pens" used to make the printout. There are two pens in the LJ4GL2 mode, and seven pens in the GLlike mode for which you can set the thickness.

### Before you start printing in the GL/2 mode

You may need to change the printer settings, depending on your output needs. Check the printer's settings to make sure they match the data you are trying to print.

4

Paper size:	Printer's paper size setting
Driver (plotter selection):	HP-GL/2 or HP-GL
Pen configuration:	Pen thickness
Plot origin:	Center or Corner
Orientation:	GLlike offers landscape only LJ4GL2 offers landscape and portrait

If you need to configure the printer settings, first switch the emulation mode, then change the settings using the printer driver, or SelecType.



**Caution:**

*Settings or data saved in the printer RAM (such as downloaded fonts) may be erased when you change the emulation mode.*

### PS3 menu

This menu is only available if the optional Adobe PostScript 3 Kit has been installed.

Proof Sign-off:  
M.Takata  
K.Nishi  
K.Pipa

\_\_\_\_\_  
\_\_\_\_\_  
\_\_\_\_\_

**Flamingo  
Rev. C**

A5 size  
7/16/98

SELEC.FM  
Pass 0

R

*Pitch*

Selects the pitch (the horizontal spacing) of the font in fixed pitch, measured in cpi (characters per inch), or you can choose proportional spacing.

*Condensed*

Turns condensed printing on or off.

*T. Margin*

Sets the distance from the top of the page to the baseline of the first printable line. The distance is measured in inches.



*Text*

Sets the page length in lines. For this option, a line is assumed to be 1 pica (1/6 inch). If you change the Orientation, Page Size, or T. Margin settings, the page length setting automatically returns to the default setting for each paper size.

*CG Table*

Use the character generator table option to select the graphics character table or the italics table. The graphics table contains graphic characters for printing lines, corners, shaded areas, international characters, Greek characters, and mathematical symbols. If you select the italics table, the upper half of the character table is defined as italic characters.

*Country*

Use this option to select one of the fifteen international symbol sets. See "International character sets" on page B-26 for samples of the characters in each country's symbol set.

Proof Sign-off:  
M.Takata  
K.Nishi  
K.Pipa

\_\_\_\_\_  
\_\_\_\_\_  
\_\_\_\_\_

## Flamingo Rev. C

A5 size  
7/16/98

SELEC.FM  
Pass 0

R

### I239X menu

I239X mode emulates IBM 2390/2391 Plus commands. For detailed information on most of the settings and parameters in the table below, refer to the previous section.

Item	Values
Font	Courier, Prestige, Gothic, Orator, Script, Presentor, Sans Serif
Pitch	10, 12, 15, 17, 20, 24 (dpi), Prop.
Code Page	437, 850, 860, 863, 865
T. Margin	0.30 ... 0.40 ... 1.50 inch in 0.05 increments
Text	1 ... 63/67* ... 81 lines
Auto CR	Off, On
Auto LF	Off, On
Alt. Graphic	Off, On
Bit Image	Dark, Light
ZeroChar	0, -
CharacterSet	1, 2

4

\* Depends on whether Letter (63) or A4 (67) paper has been selected.

\*\* The page length will vary, according to whether Letter or A4 size paper has been selected.

#### Code Page

Selects the character tables. Character tables contain the characters and symbols used by different languages. The printer prints text based in the selected character table.

#### Alt. Graphic

Turns the Alternate Graphics option on or off. The default setting is OFF.



## Chapter 5

# **Troubleshooting and Maintenance**

Introduction .....	5-2
Preventing Paper Feed and Paper Jam Problems .....	5-2
Clearing Paper Jams.....	5-3
Print Quality Problems .....	5-16
Option Problems.....	5-20
Other Problems.....	5-20
Status and Error Messages .....	5-23
Hex Dump Mode .....	5-33
Replacing the Imaging Cartridge.....	5-34
Optimizing Print Quality .....	5-38
Resolution Improvement Technology .....	5-38
Adjusting print density .....	5-38
Enhanced MicroGray .....	5-39
Resetting the Printer .....	5-40
Cleaning the Printer.....	5-40
Cleaning inside cover A.....	5-40
Cleaning the printer case .....	5-42
Transporting the Printer .....	5-42
Finding a new place for the printer .....	5-43





## Clearing Paper Jams

When a paper jam occurs, Jam xxx xxx xxx xxx message appears on the control panel. xxx indicates areas where jams may be occurring, such as LC1 (lower cassette 1). See the messages below for instructions on clearing paper jams in each area.

**Note:**

- Check for jams at all paper sources or paths indicated on the control panel. The printer cannot resume printing if the jams are not cleared.
- The control panel shows up to four paper sources or paths at the same time. Other areas where jams may be occurring will be shown on the control panel after you have checked all indicated jams.

5

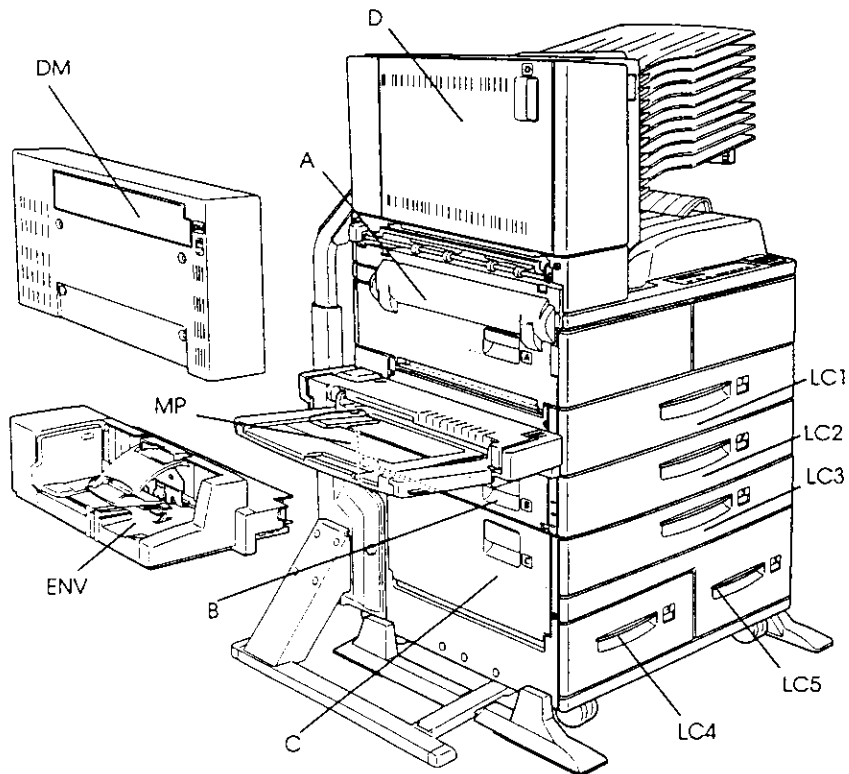



6. After that, if the control panel still indicates LC1, LC2 or LC3, completely remove the indicated cassette.

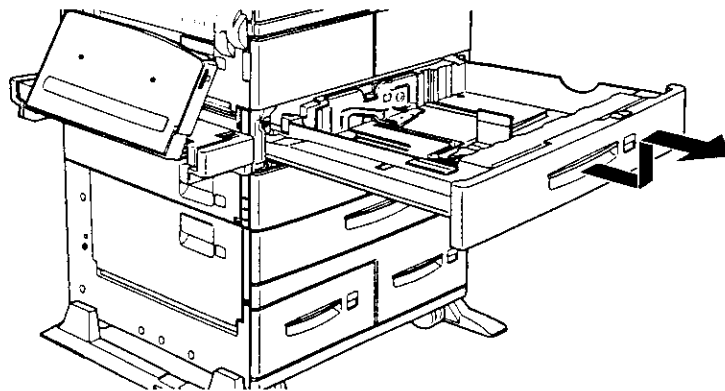

5

7. Carefully remove any sheets that have fed part way into the printer.

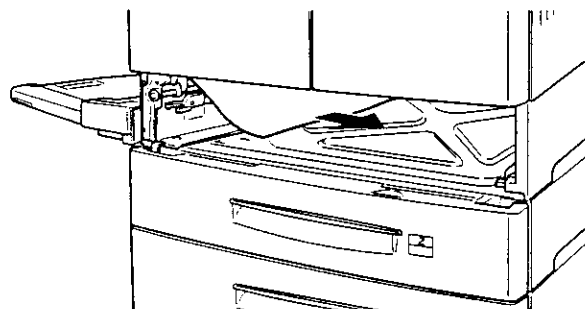

8. Reinstall the removed cassette.



**Caution:**

*if you completely removed a cassette, be sure to put it back into its original position. Changing cassette 1 with cassette 2 (or cassette 3, if installed) causes improper paper feeding.*

Proof Sign-off:  
M.Takata  
K.Nishi  
K.Pipa

\_\_\_\_\_  
\_\_\_\_\_  
\_\_\_\_\_

## Flamingo Rev. C

A5 size  
7/16/98

TROUBLE.FM  
Pass 0

R

- Carefully remove any sheets that have fed part way into the printer.

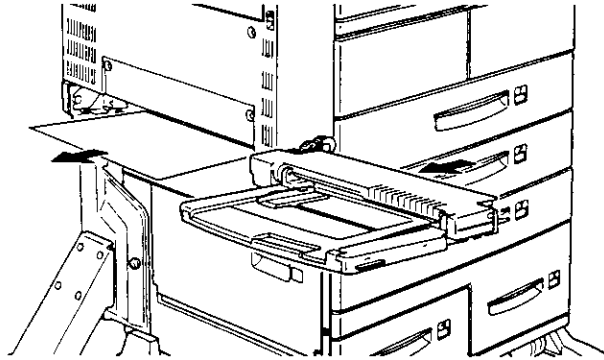

- Reinstall the removed tray and reinsert the paper.

5

---

### Jam A

---

This message indicates that there may be a paper jam inside cover A.

- Open cover A on the left side of the printer. If the optional Duplex Unit is installed, open cover DM first, then open cover A. If the optional Envelope Feeder is also installed, remove it before opening the Duplex Unit.



**Warning:**

*When opening the printer, do not touch the hot areas indicated on the caution labels inside cover A.*

- Remove any paper you find jammed inside the printer.





3. If the paper is difficult to remove, use the gear lever inside cover A shown below. Push the lever in and up repeatedly to feed the jammed paper back out cover A.



**Warning:**

*When opening the printer, do not touch the hot areas indicated on the caution labels inside cover A.*

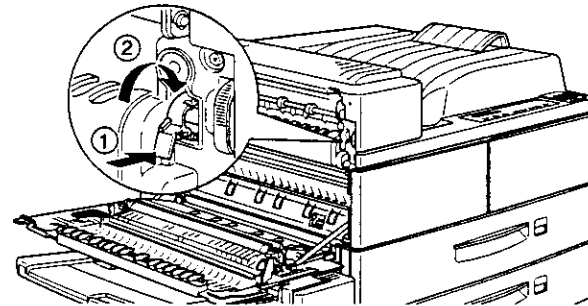

5

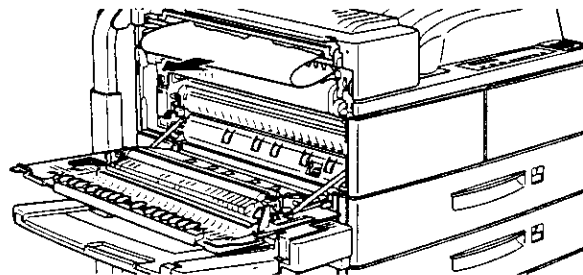

4. If necessary, open the front cover to remove the imaging cartridge and any paper left in the paper feed path, and then reinsert the imaging cartridge.

If you do not find any jammed paper, it may be in another area.

5. Close the front cover, if opened, then close cover A. Close the Duplex Unit, then reinstall the envelope feeder, if you have these options.



---

**Jam LC4 or LC5 (LC4 and LC5 are both part of an option)**

---

This message indicates that there may be a paper jam in optional lower paper cassette 4 or 5.

1. Pull out the indicated cassette (lower paper cassette 4 or 5).
2. Remove any wrinkled or folded sheets.

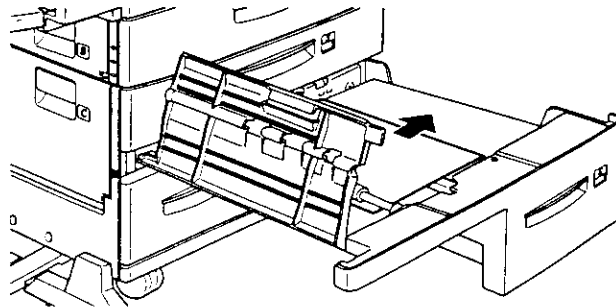
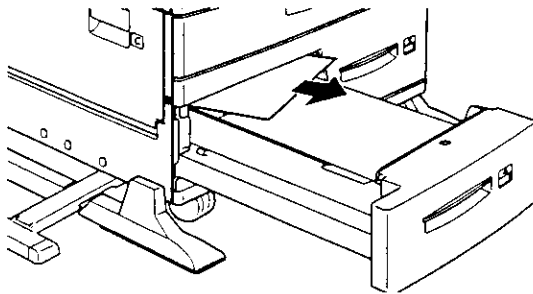

3. Tap the edges of the paper stack on a flat surface. Then reload the paper in the MP Tray, making sure it is evenly aligned and rests below the maximum paper mark.

Make sure you are using the correct paper size and that your paper meets the specifications for this printer.

If you do not find any jammed paper, reinstall the tray into the cassette.



1. Carefully pull out the jammed paper, along with all the loaded envelopes.

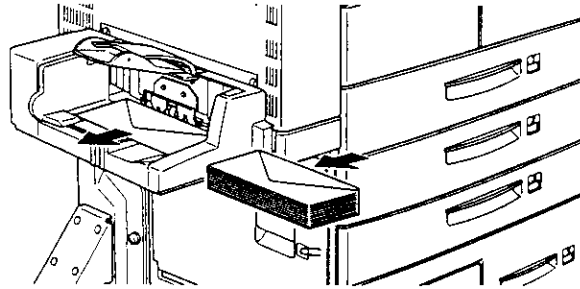

2. Tap the edges of the envelope stack on a flat surface. Then reload the envelopes in the envelope tray, making sure they are evenly aligned and rest below the maximum paper mark.

5

Make sure you are using the correct envelope size and that your envelopes meet the specifications for this printer.

3. Clear any other paper jams indicated on the control panel.
4. After that, if the control panel still indicates Jam EMU, completely remove the envelope tray.
5. Carefully remove all the envelopes in the cassette, along with any envelopes that have fed part way into the printer.

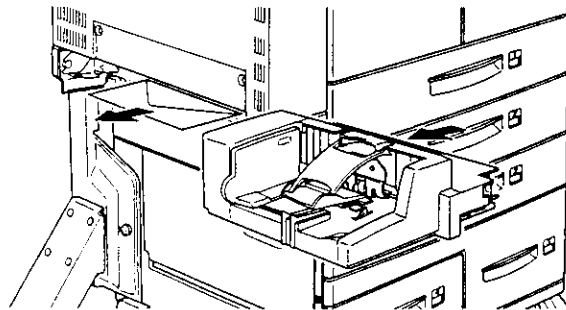

6. Reinstall the removed feeder and reinsert the envelopes.



4. Check the bins for any jammed paper and remove it.

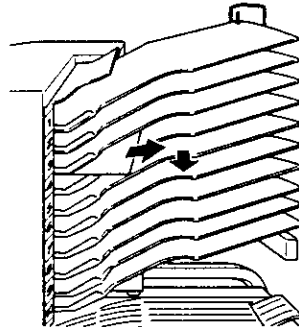

5. When the paper jam is cleared completely, the jammed page's print data is automatically reprinted.

5

If the control panel indicates another area, clear the paper jam there.

---

#### Jam DM (DM is part of an option)

---

This message indicates that there may be a paper jam inside cover DM, or the optional Duplex Unit. If the optional Envelope Feeder is also installed, remove it before opening the Duplex Unit.

1. Open cover DM on left side of the Duplex Unit.

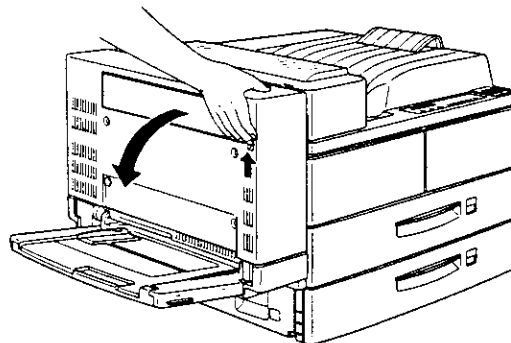

Proof Sign-off:

M.Takata

K.Nishi

K.Pipa

\_\_\_\_\_  
\_\_\_\_\_  
\_\_\_\_\_

## Flamingo Rev. C

A5 size  
7/16/98

TROUBLE.FM  
Pass 0

R

Clean internal printer components by printing several pages with only one character per page.

There may be a problem with the imaging cartridge. Remove the cartridge, shake it from side to side, and then reinstall it. If this does not solve the problem, replace the imaging cartridge as described in "Replacing the Imaging Cartridge" on page 5-34.

---

### Horizontal black or white bands appear in your printout, or the printer prints a blank page

---

Install a new imaging cartridge as described in "Replacing the Imaging Cartridge" on page 5-34.

5

---

### Uneven darkness

---

Take out the imaging cartridge, shake it from side to side, and reinstall it.

Your paper may be moist or damp. Printing is sensitive to moisture absorbed by the paper. Do not store your paper in a humid or damp environment.

Install a new imaging cartridge as described in "Replacing the Imaging Cartridge" on page 5-34. Then print several pages to check the print quality.

---

### Toner smudges

---

Remove the imaging cartridge, shake it from side to side to distribute the toner, and wipe the bottom of it with a clean, dry cloth.

Clean the paper path inside the printer using a clean, soft, and lint-free cloth.

Proof Sign-off:  
M.Takata  
K.Nishi  
K.Pipa

\_\_\_\_\_  
\_\_\_\_\_  
\_\_\_\_\_

**Flamingo**  
**Rev. C**

A5 size  
7/16/98

TROUBLE.FM  
Pass 0

R

---

### Printed image is light or faint

---

Darken the Density setting using the printer driver or the SelecType Config Menu.

Your paper may be moist or damp. Printing is sensitive to moisture absorbed by the paper. The higher the moisture content in the paper, the lighter the printed output. Do not store your paper in a humid or damp environment.

Take out the imaging cartridge, shake it from side to side to distribute the toner, and then reinstall it. If the problem persists, replace the imaging cartridge as described in "Replacing the Imaging Cartridge" on page 5-34.

The Toner Save mode may be on. Turn off the Toner Save mode using the printer driver, OneTouch mode 2, or SelecType Config Menu.

5

---

### Image is too dark

---

The Density setting may be incorrect. Change the print density using the printer driver or the SelecType Config Menu.

If the problem persists, replace the imaging cartridge as described in "Replacing the Imaging Cartridge" on page 5-34.

---

### Non-printed side of the page is dirty

---

Toner may have spilled in the paper feed path. Remove the imaging cartridge and then clean the paper path of the printer using a soft, lint-free cloth. See "Cleaning the Printer" on page 5-40 for more information.



**Warning:**

*When opening the printer, do not touch the hot areas indicated on the caution labels inside cover A.*

Proof Sign-off:  
M.Takata  
K.Nishi  
K.Pipa

\_\_\_\_\_  
\_\_\_\_\_  
\_\_\_\_\_

**Flamingo**  
**Rev. C**

A5 size  
7/16/98

TROUBLE.FM  
Pass 0

R

If the electrical outlet is controlled by an outside source such as a wall switch, make sure the switch is turned on, or plug another electrical device into the outlet to check whether the outlet is operating properly.

---

**The On Line light is on but nothing prints.**

---

Your computer may not be properly connected to the printer. Refer to the connecting instructions in the *Hardware Setup Guide*.

The interface cable may not be securely plugged in. Check both ends of the cable between the printer and the computer.

Make sure that your interface cable meets the specifications for the printer and computer.

If you are using the parallel interface, set the Speed setting (on the Parallel menu) to match the value that the computer requires.

Make sure that your software is properly set up for your printer.

The imaging cartridge may be empty. Replace it as described in "Replacing the Imaging Cartridge" on page 5-34.

5

---

**The printer doesn't print and the On Line light is off.**

---

Press the On Line button once to put the printer on line (the On Line light comes on).

---

**A font selected with software commands won't print.**

---

The selected font is not installed in your printer. Be sure you have installed the correct font. See Appendix D, "Working with Fonts" for more information.

Proof Sign-off:  
M.Takata  
K.Nishi  
K.Pipa

\_\_\_\_\_  
\_\_\_\_\_  
\_\_\_\_\_

## Flamingo Rev. C

A5 size  
7/16/98

TROUBLE.FM  
Pass 0

R

---

### SelecType does not function as expected.

---

Software programs override SelecType settings. Use software settings instead of SelecType settings whenever possible.

Your settings may have been changed by your software program. Perform a factory reset (initialize) with the `SelecType Init` function on the SelecType Setup Menu. For more information, see Chapter 4, "SelecType".

You may not have reset the printer after making settings. Press the ALT and Continue buttons at the same time to reset the printer and enable the new settings.

5

---

### Cover A will not close completely

---

The imaging cartridge is not installed correctly. See "Replacing the Imaging Cartridge" on page 5-34.

---

## Status and Error Messages

This section contains an alphabetical list of status, error, and warning messages that appear in the control panel display.

---

### A Cover Open

---

Cover A, on the left side of the printer, is open. Pull up the latch on cover A, then close the cover by pushing it into the printer.



**Warning:**

*Do not touch the hot areas indicated on the caution labels inside cover A.*



Proof Sign-off:  
M.Takata  
K.Nishi  
K.Pipa

\_\_\_\_\_  
\_\_\_\_\_  
\_\_\_\_\_

**Flamingo**  
**Rev. C**

A5 size  
7/16/98

TROUBLE.FM  
Pass 0

R

---

### D Cover Open

---

Cover D, on the left side of the optional Multibin Unit, is open.  
Pull the latch on cover D and push it into the unit to close.

---

### DM Cover Open

---

Cover DM, on the left side of the optional Duplex Unit, is open.  
Pull the latch on cover DM and push back to close.

---

### DM Error #007

---

An error has occurred on the optional Duplex Unit. Turn off the printer, wait 5 seconds, then turn the printer back on.

If the message still appears, call your dealer or a qualified service person.

5

---

### Duplex Mem Overflow

---

There is not enough memory for duplex printing. The printer prints only on the top side and ejects the paper. To correct this error, follow the directions below.

If Auto Cont is Off in the SelectType Config menu, (1) press Continue or (2) reset the printer by pressing the ALT and Reset at the same time.

If Auto Cont is On in the SelectType Config menu, the error is corrected automatically.

---

### Face-down Full

---

The face-down tray is full with printed sheets. Remove the sheets from the face-down tray and press Continue.

Proof Sign-off:  
M.Takata  
K.Nishi  
K.Pipa

\_\_\_\_\_  
\_\_\_\_\_  
\_\_\_\_\_

## Flamingo Rev. C

A5 size  
7/16/98

TROUBLE.FM  
Pass 0

R

---

### Invalid Aux I/F Card

---

The printer cannot read the installed optional interface card. Turn off the printer, then remove the card. Reinstall a proper card.

---

### Invalid ROM x

---

The ROM module in slot A or B is not installed correctly or is invalid for this printer. Check if you are using a proper ROM module or reinstall it. See "Installing a memory module" on page 3-47 for installation instructions.

---

### Invalid Option

---

An option is not installed correctly or invalid for this printer. See "Printer Options" on page 3-2 to make sure you are using options made for this printer, or see "Installing and Removing Options" on page 3-3 to reinstall the options.

5

---

### Jam xxx xxx xxx xxx

---

Paper is jammed in the tray, cassettes, covers, or other devices indicated by xxx. Check and remove the jammed paper. See "Clearing Paper Jams" on page 5-3 for help with clearing the jam. See "Preventing Paper Feed and Paper Jam Problems" on page 5-2 for advice on preventing this problem.

---

### Job Cancel

---

The printer job sent to your printer is canceled.

Proof Sign-off:  
M.Takata  
K.Nishi  
K.Pipa

\_\_\_\_\_  
\_\_\_\_\_  
\_\_\_\_\_

## **Flamingo Rev. C**

A5 size  
7/16/98

TROUBLE.FM  
Pass 0

R

You can also clear this error by turning the printer off and back on again. However, it may be necessary to reduce the number or size of fonts, reduce the number or size of graphics, lower the resolution, or add more memory to the printer.

---

### **Multibin Error #007**

---

An error occurred with the optional Multibin Unit. Turn off the printer, wait 5 seconds, then turn it back on.

If the message still appears, contact your dealer or a qualified service person.

---

### **Multibin<x> Full**

---

The bin x (1 to 10) on the optional Multibin Unit is full with printed sheets. Remove the sheets from bin x and press Continue.

5

---

### **Need Memory**

---

Your printer lacks the amount of the printer memory required to print your print job. Reduce the images or texts on the print job, or install an optional memory module. See "Memory modules" on page 3-47.

---

### **Offline**

---

The printer is not ready to print. Press the Online button.

---

### **Outbin Select Error**

---

The printer cannot feed paper to the output tray you selected, because of a paper size discrepancy or other problem. The printed sheet is fed to the face-down tray.

Proof Sign-off:  
M.Takata \_\_\_\_\_  
K.Nishi \_\_\_\_\_  
K.Pipa \_\_\_\_\_

## Flamingo Rev. C

A5 size  
7/16/98

TROUBLE.FM  
Pass 0

R

---

### Reset to Save

---

You have changed the SelecType setting but the new setting is not activated immediately after exiting SelecType. To activate the new setting, do one of the following: (1) exit SelecType by pressing Continue or On Line (the new setting is activated after the current print job is finished), or (2) reset the printer by pressing ALT and Reset at the same time.

---

### ROM Check

---

The printer is checking the ROM.

5

---

### RAM check

---

The printer is checking the RAM.

---

### Self Test

---

The printer is performing a quick internal check.

---

### Set MP Tray

---

The MP Tray is not installed or is installed incorrectly. Install or reinstall the MP Tray. See "Installing the envelope feeder" on page 3-28. Then turn off the printer, wait 5 seconds, and turn the printer back on.

---

### Set ENV Tray

---

The optional Envelope Feeder, is not installed or is installed incorrectly. Install or reinstall the optional envelope feeder. See "Installing the envelope feeder" on page 3-28. Then turn off the printer, wait 5 seconds, and turn the printer back on.

Proof Sign-off:  
M.Takata  
K.Nishi  
K.Pipa

\_\_\_\_\_  
\_\_\_\_\_  
\_\_\_\_\_

## **Flamingo Rev. C**

A5 size  
7/16/98

TROUBLE.FM  
Pass 0

R

---

### **Hex Dump Mode**

Hex Dump Mode (also called data dump) is a special feature that makes it easy for experienced users to find the cause of communication problems between the printer and the computer. In the Hex Dump Mode, the printer produces an exact printout of the codes it receives.

1. Make sure the paper is loaded and the printer is off.
2. Hold down the Form Feed button while you turn on the printer. Make sure you hold the button down until you see the message `Hex Dump` on the display.
3. Run any program that causes the printer to print. Your printer prints out all the codes it receives in hexadecimal format.
4. To turn off the Hex Dump Mode, turn off the printer or reset it by pressing and holding the ALT and Continue buttons at the same time until you see the message `Reset All` on the display.

5



4. While holding the new imaging cartridge horizontally, gently shake it a few times to distribute the toner evenly.

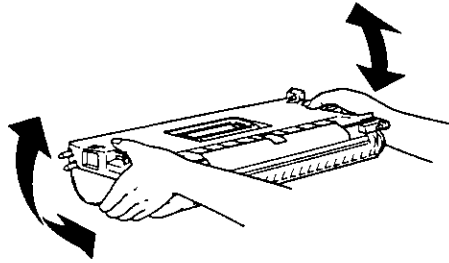

5. Remove the attached sheet.

5

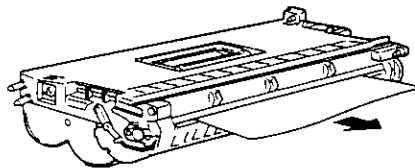

6. Open cover A by pulling the latch, then open the front cover.

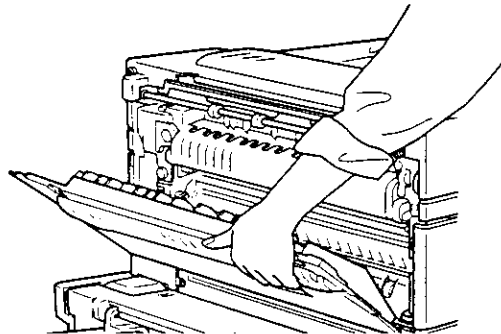

**Warning:**

When opening the printer, do not touch the hot areas indicated on the caution labels inside cover A.

Proof Sign-off:  
M.Takata  
K.Nishi  
K.Pipa



## Flamingo Rev. C

A5 size  
7/16/98

TROUBLE.FM  
Pass 0

R

10. Release the front cover; it will close automatically.

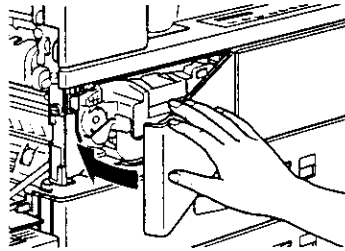

11. Close cover A by pushing it up and into the printer.

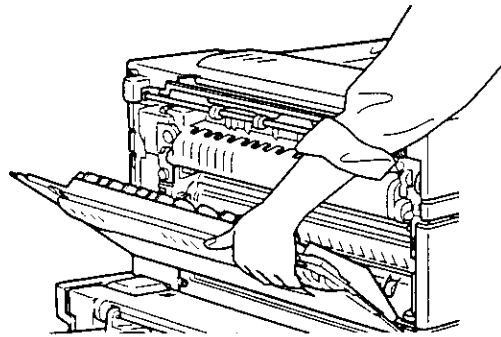

5



**Warning:**

*Do not touch the hot areas indicated on the caution labels inside cover A.*



**Caution:**

*Never transport the printer with the imaging cartridge installed.*

Proof Sign-off:  
M.Takata  
K.Nishi  
K.Pipa

\_\_\_\_\_  
\_\_\_\_\_  
\_\_\_\_\_

## Flamingo Rev. C

A5 size  
7/16/98

TROUBLE.FM  
Pass 0

R

### Using the printer driver

Change the Density setting on the Panel menu of the printer driver.

### Using SelecType

Follow the instructions in the section on SelecType to change this setting. Make this change in the Config Menu (see "Config Menu" on page 4-12).

#### Note:

*Increasing the print density increases toner consumption. If you select darker printing, you may need to replace the toner cartridge more often.*

### Enhanced MicroGray

Enhanced MicroGray (Enh. MG) is EPSON's new printer technology created especially for high quality output of photos and other detailed images.

5



Enh. MG off

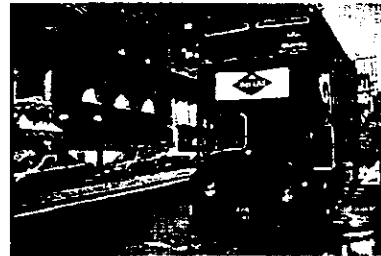

Enh. MG on

To use the Enhanced MicroGray function, in the printer driver select Enh. MG on the Graphics menu.





2. Open cover A.



**Warning:**

*Opening the printer exposes the fuser and paper path parts, which is marked by a caution label. If the printer has been in use, the fuser may be hot; do not touch it. Let the printer cool before you clean the inside.*

3. Wipe the area shown below with a soft, clean cloth.

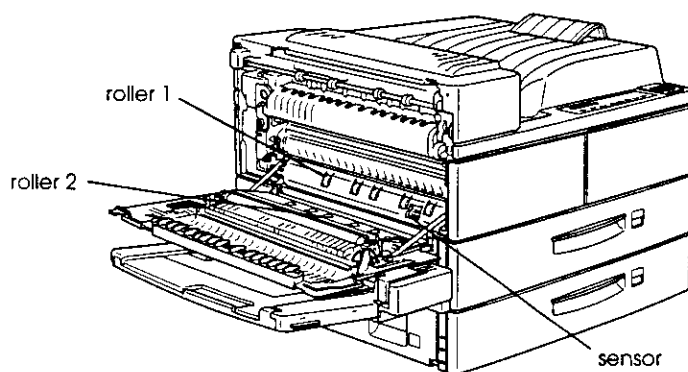

4. With cover A opened, open the front cover.
5. Remove the imaging cartridge from the printer.
6. Carefully remove any dirt inside with a soft cloth.
7. Reinstall the imaging cartridge.
8. Close the front cover and cover A.

**Note:**

*If a large amount of toner is spilled, call a qualified service person.*

Proof Sign-off:  
M.Takata  
K.Nishi  
K.Pipa

\_\_\_\_\_  
\_\_\_\_\_  
\_\_\_\_\_

## Flamingo Rev. C

A5 size  
7/16/98

TROUBLE.FM  
Pass 0

R

### Finding a new place for the printer

When relocating the printer, allow adequate space for easy operation and maintenance as shown below.

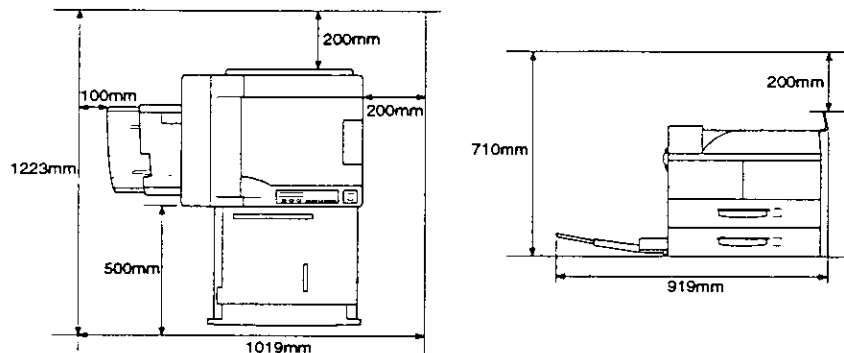

5

To install any of the following options, you will need the indicated amount of additional space.

**Large Capacity Paper Unit** adds 426 mm (16.77 inches) to the bottom of the printer.

**Face-up Tray** adds 10 mm (0.39 inches) to the left side of the printer.

**Face-up Tray / Duplex Unit** combination adds 91 mm (3.58 in.) to the left side of the printer.

**Multibin Unit** adds 20 mm (0.79 inches) to the right, 86 mm (3.39 inches) to the back, and 470 mm (18.5 inches) to the top of the printer.

Proof Sign-off:  
M.Takata  
K.Nishi  
K.Pipa

\_\_\_\_\_  
\_\_\_\_\_  
\_\_\_\_\_

**Flamingo**  
**Rev. C**

A5 size  
7/16/98

APPSPEC.FM  
Pass 0

R

*Appendix A*

**Technical Specifications**

Paper Specifications .....	A-2
Printer .....	A-3
General .....	A-3
Environmental .....	A-4
Mechanical .....	A-4
Electrical .....	A-5
Interface .....	A-5
Parallel interface .....	A-5
Ethernet Interface .....	A-11
Options and Consumables .....	A-12
Large Capacity Paper Unit (C81303*) .....	A-12
Duplex Unit (C81304*) .....	A-13
Multibin Unit (C81305*) .....	A-13
Face-up Tray (C81306*) .....	A-14
Envelope Feeder (C81307*) .....	A-14
Imaging Cartridge (S051060) .....	A-15



Proof Sign-off:  
M.Takata  
K.Nishi  
K.Pipa

\_\_\_\_\_  
\_\_\_\_\_  
\_\_\_\_\_

## Flamingo Rev. C

A5 size  
7/16/98

APPSPEC.FM  
Pass 0

R



**Caution:**

- Only load the paper sizes listed above.
- Available paper types and sizes depend on the paper source being used. See Chapter 1, "Printing with the EPL-N4000".

Printable area: 4 mm minimum margin on all sides  
(3.4 mm minimum left and right margin  
when you print with 80-column setting from  
DOS applications.)

**Note:**

Printable area varies according to the emulation mode.

---

## Printer

### General

Printing method:	Laser beam scanning and dry electrophotographic process
Resolution:	600 × 600 dpi
Printing speed:	Up to 40 pages per minute with A4/Letter depending on the font and quantity of data
First print:	10 seconds minimum with A4/Letter
Warm-up time:	60 seconds maximum at rated voltage
Paper feed:	Automatic or manual feed
Paper feed alignment:	Center alignment for all sizes
Input paper supply (75g/m <sup>2</sup> paper):	Up to 50 sheets in the MP Tray Up to 500 sheets in lower cassette 1 Up to 500 sheets in lower cassette 2
Paper eject:	Face down
Paper eject capacity (75g/m <sup>2</sup> paper):	500 sheets

A

Proof Sign-off:  
M.Takata  
K.Nishi  
K.Pipa

\_\_\_\_\_  
\_\_\_\_\_  
\_\_\_\_\_

# Flamingo Rev. C

A5 size  
7/16/98

APPSPEC.FM  
Pass 0

R

## Electrical

	120 V model	230 V model
Voltage	108 V to 132 V	198 V to 264 V
Rated frequency	50 Hz to 60 Hz	
Rated current	9.5 A	5 A
Power consumption	Less than 1180 W	Less than 1240 W
Power consumption * in Standby mode	Less than 45 W	

\* No option installed

**Note:**

Check the label on the back of the printer for the voltage of your printer.

## Interface



### Parallel interface

The parallel (IEEE 1284-I compliant) interface connector pin assignments are shown in the table below. The column heading "Direction" refers to the direction of signal flow as viewed from the printer.

Pin No.	Direction	IEEE 1284-B connector		
		Compatibility	Nibble	ECP
1	IN	nStrobe	HostClk	
2	IN/OUT	DATA1		
3	IN/OUT	DATA2		
4	IN/OUT	DATA3		
5	IN/OUT	DATA4		
6	IN/OUT	DATA5		
7	IN/OUT	DATA6		



*nstrobe/HostClk*

Compatibility mode:	Latch pulse used to read in print data. When low, DATA is valid.
Negotiation phase:	Latch pulse used to read in extensibility request values.
Nibble mode:	Always high.
ECP mode:	Used to transfer data and addresses from the host to the printer with handshaking via PeriphAck (Busy).

*DATA 1 to DATA 8 (bidirectional, but may always be an input if ECP or EPP mode is not supported)*

Compatibility mode:	Forward channel data.
Negotiation phase:	Extensibility request value.
Nibble mode:	Not used.
ECP mode:	Bidirectional data.



*nACK/PtrClk/PeriphClk*

All modes:	DATA 8 is the MSB, DATA 1 is the LSB.
Compatibility mode:	Acknowledgment low pulse in order to indicate that data was transferred from the host.
Negotiation phase:	Low signal indicates IEEE 1284 is supported; set to high afterwards to indicate that the Xflag and "data available" flag are valid.
Reverse data transfer phase:	In nibble mode, a low signal indicates that the nibble data is valid.
Reverse idle phase:	When switched from low to high, generates an interrupt that notifies the host that there is data available.
ECP mode:	Used to transfer data from the printer to the host with handshaking via HostAck (nAutoFd).



*Set/Xflag*

Compatibility mode:	Always high.
Negotiation phase:	Xflag indicates the extensibility flag. Used to respond to the extensibility request value sent from the host.
Reverse data transfer phase:	In nibble mode, this signal serves as nibble data bit 1 and then 5.
Reverse idle phase:	Same as negotiation phase.
ECP mode:	Same as negotiation phase.

*nAutoFd/HostBusy/HostAck*

Compatibility mode:	Not used.
Negotiation phase:	In order to request 1284 mode, this signal is set low and IEEE 1284active (nSelectIn) is set high. Afterwards, this signal is set high when PtrClk (nAck) is set low.
Reverse data transfer phase:	In nibble mode, setting this signal low indicates to the printer that the host is ready to receive data. When this signal is subsequently set high, it indicates that the host received the data.
Reverse idle phase:	This signal is set high in response to a PtrClk (nAck) low pulse in order to return to be reverse data phase. If this signal is set high at the same time that IEEE 1284 Active (nSelectIn) is set low, the IEEE 1284 idle phase is aborted and the interface returns to compatibility mode.
ECP mode:	Used for reverse direction flow control. Also used for handshaking via PeriphClk (nAck).



Proof Sign-off:  
M.Takata  
K.Nishi  
K.Pipa

\_\_\_\_\_  
\_\_\_\_\_  
\_\_\_\_\_

## Flamingo Rev. C

A5 size  
7/16/98

APPSPEC.FM  
Pass 0

R

### *nSelectIn/IEEE1284active*

Compatibility mode:	Always low.
Negotiation phase:	This signal is set high at the same time that HostBusy is low in order to request 1284 mode.
Reverse data transfer phase:	This signal is set high to indicate that the bus direction is from the printer to the host. This signal is set low to terminate 1284 mode, setting the bus direction from the host to the printer.
Reverse idle phase:	Same as reverse data transfer phase.
ECP mode:	Always high. This signal is set low to terminate ECP mode and return to compatibility mode.

### *GND*

Twisted pair return signal.

### *CG*

Connected to the printer chassis. This signal and GND are connected.

### *+5V*

Pull up to + 5 V with 1 k $\Omega$ .

### **Ethernet Interface**

You can use an IEEE 802.3 10BASE-T/100BASE-TX straight-through shield twisted pair modular cable via RJ45 connector.

A





Dimensions and weight:

Height	426 mm (168 inches)
Width	520 mm (20.5 inches)
Depth	523 mm (20.6 inches)
Weight	35 kg (77.2 lb)

**Duplex Unit (C81304\*)**

Paper size:	A3, A4, Ledger, Legal, GLG, Letter, GLT, Executive, HLT
Paper weight:	60 to 90 g/m <sup>2</sup> (16 to 24 lb)
Feeding speed:	14.6 seconds or less for the first A4 or Letter-size sheet; 32 pages per minute for subsequent A4 or Letter-size sheets (from lower cassette 1 to face-down tray)
AC power supply:	DC 5V and 24V supplied by the printer



Dimensions and weight:

Height	369 mm (14.5 inches)
Width	484 mm (19.1 inches)
Depth	92 mm (3.6 inches)
Weight	5.5 kg (12.1 lb)

**Multibin Unit (C81305\*)**

Paper size:	A3, A4, A5, Ledger, Legal, GLG, Letter, Executive, HLT
Paper type:	Plain paper, recycled paper
Paper weight:	60 to 90 g/m <sup>2</sup> (16 to 24 lb)
AC power supply:	DC 5V and 24V supplied by the printer

Proof Sign-off:  
M.Takata  
K.Nishi  
K.Pipa

\_\_\_\_\_  
\_\_\_\_\_  
\_\_\_\_\_

## Flamingo Rev. C

A5 size  
7/16/98

APPSPEC.FM  
Pass 0

R

### Imaging Cartridge (S051060)

Storage temperature:	0 to 35°C (32 to 95°F)
Storage humidity:	15 to 85% RH
Shelf life:	18 months after production
Life:	Up to 20,000 pages under the following conditions: Letter or A4-size paper, continuous printing, and 5% print ratio

The number of pages you can print with an imaging cartridge varies depending on the type of printing. If you print a few pages at a time or print dense text exceeding the 5% print ratio, your cartridge may print fewer pages.



Proof Sign-off:  
M.Takata  
K.Nishi  
K.Pipa

\_\_\_\_\_  
\_\_\_\_\_  
\_\_\_\_\_

**Flamingo  
Rev. C**

A5 size  
7/16/98

APPSYM.FM  
Pass 0

R

*Appendix B*

---

**Symbol Sets**

Introduction to Symbol Sets ..... B-2

In LJ4 Emulation Mode ..... B-3  
    International Set for ISO sets ..... B-21

In ESC/P 2 or FX Modes ..... B-22  
    International character sets ..... B-26  
    Characters available with the ESC (^ command) ..... B-27

In I239X Emulation Mode ..... B-28

In EPSON GL/2 Mode ..... B-28

**B**

**In LJ4 Emulation Mode**

The following table lists the symbol sets available in LJ4 emulation mode. A table of the characters for each set is included later in this chapter.

Symbol set name	Symbol set ID for ESC (	Available typefaces (see next page)
Roman-8*	8U	43 typefaces + bitmap**
(includes another 19 sets)		
Roman Extension	0E	bitmap
ECM94-1	0N	43 typefaces + bitmap
Legal	1U	43 typefaces + bitmap
8859-2 ISO	2N	43 typefaces + bitmap
PstMath	5M	35 typefaces
8859-9 ISO	5N	43 typefaces + bitmap
WtTurkish	5T	43 typefaces
MsPublishing	6J	35 typefaces
VeMath	6M	35 typefaces
DeskTop	7J	43 typefaces
Math-8	8M	35 typefaces
WiE.Europe	9E	43 typefaces
PcTk437	9T	43 typefaces
Windows	9U	43 typefaces
PstText	10J	43 typefaces
IBM-US	10U	43 typefaces + bitmap
IBM-DN	11U	43 typefaces + bitmap
McText	12J	43 typefaces
PcMultilingual	12U	43 typefaces + bitmap
VeInternational	13J	43 typefaces
VeUS	14J	43 typefaces
PiFont	15U	35 typefaces
PcE.Europe	17U	43 typefaces
Symbol	19M	Symbol Set SWA
WiAnsi	19U	43 typefaces
Wingdings	579L	More WingBats SWM
OCR A	00	OCR A
OCR B	10	OCR B
OCR B Extension	3Q	OCR B
Code 3-9	0Y	Code 3-9 (2 types)
EAN/UPC	8Y	EAN/UPC (2 types)



\* The other 19 sets are the following: Norweg1, Italian, Swedish, ANSI ASCII, UK, French, German, Spanish, Norweg2, French2, HP German, JIS ASCII, HP Spanish, Chinese, IRV, Swedis2, Portuguese, IBM Portuguese, and IBM Spanish. These are partial variations of the Roman-8 set.

\*\*"Bitmap" means the "Line Printer" typeface.

Proof Sign-off:  
M.Takata  
K.Nishi  
K.Pipa

\_\_\_\_\_  
\_\_\_\_\_  
\_\_\_\_\_

**Flamingo  
Rev. C**

A5 size  
7/16/98

APPSYM.FM  
Pass 0

R

*Roman-8 (8U)*

*Roman Extension (0E)*

**B**

Proof Sign-off:

M.Takata

K.Nishi

K.Pipa

\_\_\_\_\_  
\_\_\_\_\_  
\_\_\_\_\_

**Flamingo**  
**Rev. C**

A5 size  
7/16/98

APPSYM.FM  
Pass 0

R

*8859-2 ISO (2N)*

*PsMath (5M)*

**B**

Proof Sign-off:  
M.Takata  
K.Nishi  
K.Pipa

\_\_\_\_\_  
\_\_\_\_\_  
\_\_\_\_\_

**Flamingo  
Rev. C**

A5 size  
7/16/98

APPSYM.FM  
Pass 0

R

*MsPublishing (6J)*

*VeMath (6M)*

**B**

Proof Sign-off:  
M.Takata  
K.Nishi  
K.Pipa

\_\_\_\_\_  
\_\_\_\_\_  
\_\_\_\_\_

**Flamingo  
Rev. C**

A5 size  
7/16/98

APPSYM.FM  
Pass 0

R

*WIE.Europe (9E)*

*PcTk437 (9T)*

**B**



Proof Sign-off:  
M.Takata  
K.Nishi  
K.Pipa

\_\_\_\_\_  
\_\_\_\_\_  
\_\_\_\_\_

**Flamingo**  
**Rev. C**

A5 size  
7/16/98

APPSYM.FM  
Pass 0

R

**IBM-US (10U)**

**IBM-DN (11U)**

**B**

Proof Sign-off:  
M.Takata  
K.Nishi  
K.Pipa

\_\_\_\_\_  
\_\_\_\_\_  
\_\_\_\_\_

**Flamingo  
Rev. C**

A5 size  
7/16/98

APPSYM.FM  
Pass 0

R

*VeInternational (13J)*

*VeUS (14J)*

**B**

Proof Sign-off:  
M.Takata  
K.Nishi  
K.Pipa

\_\_\_\_\_  
\_\_\_\_\_  
\_\_\_\_\_

**Flamingo**  
**Rev. C**

A5 size  
7/16/98

APPSYM.FM  
Pass 0

R

**Symbol (19M)**

**WiAnsi (19U)**

**B**

Proof Sign-off:  
M.Takata  
K.Nishi  
K.Pipa

\_\_\_\_\_  
\_\_\_\_\_  
\_\_\_\_\_

**Flamingo  
Rev. C**

A5 size  
7/16/98

APPSYM.FM  
Pass 0

R

OCR B (10)

OCR B Extension (3Q)

B

Proof Sign-off:  
M.Takata  
K.Nishi  
K.Pipa

\_\_\_\_\_  
\_\_\_\_\_  
\_\_\_\_\_

**Flamingo  
Rev. C**

A5 size  
7/16/98

APPSYM.FM  
Pass 0

R

**International Set for ISO sets**

To obtain the symbol sets listed below, substitute the characters in the ANSI ASCII sets with the characters in the table below.

Iso set	ASCII code hex											
	23	24	40	5B	5C	5D	5E	60	7B	7C	7D	7E
ANSI ASCII (0U)												
Norweg 1 (0D)												
French (0F)												
HP German (0G)												
Italian (0I)												
JIS ASCII (0K)												
Swedis 2 (0S)												
Norweg 2 (1D)												
UK (1E)												
French 2 (1F)												
German (1G)												
HP Spanish (1S)												
Chinese (2K)												
Spanish (2S)												
IRV (2U)												
Swedish (3S)												
Portuguese (4S)												
IBM Portuguese (5S)												
IBM Spanish (6S)												

B



Proof Sign-off:  
M.Takata  
K.Nishi  
K.Pipa

\_\_\_\_\_  
\_\_\_\_\_  
\_\_\_\_\_

**Flamingo  
Rev. C**

A5 size  
7/16/98

APPSYM.FM  
Pass 0

R

*PC437 (U.S./Standard Europe)*

*PC850 (Multilingual)*

*PC860 (Portuguese)*

**B**

Proof Sign-off:  
M.Takata  
K.Nishi  
K.Pipa



**Flamingo  
Rev. C**

A5 size  
7/16/98

APPSYM.FM  
Pass 0

R

**BRASCI**

**Abicomp**

**Italic**

**B**

No characters are available for hex code 15 in the italic character table.



Proof Sign-off:  
M.Takata  
K.Nishi  
K.Pipa

\_\_\_\_\_  
\_\_\_\_\_  
\_\_\_\_\_

**Flamingo  
Rev. C**

A5 size  
7/16/98

APPSYM.FM  
Pass 0

R

**Characters available with the ESC (^) command**

To print the characters in the table below, use the ESC (^) command.

**B**

Proof Sign-off:  
M.Takata  
K.Nishi  
K.Pipa

\_\_\_\_\_  
\_\_\_\_\_  
\_\_\_\_\_

**Flamingo  
Rev. C**

A5 size  
7/16/98

APPCOMM.FM  
Pass 0

R

*Appendix C*

---

**Command Summary**

LaserJet 4 (LJ4) Emulation Commands .....	C-3
GL/2 context commands .....	C-6
ESC/P 2 and FX Commands .....	C-9
ESC/P 2 mode .....	C-9
FX mode .....	C-12
PJL Commands .....	C-15
I239X Emulation Commands .....	C-16
Page format .....	C-16
Text .....	C-17
Auxiliary functions .....	C-18
AGM mode .....	C-19

C

Proof Sign-off:  
M.Takata  
K.Nishi  
K.Pipa

\_\_\_\_\_  
\_\_\_\_\_  
\_\_\_\_\_

## Flamingo Rev. C

A5 size  
7/16/98

APPCOMM.FM  
Pass 0

R

---

### LaserJet 4 (LJ4) Emulation Commands

This section lists the printer commands supported in the LJ4 emulation mode. For more information on printer commands, see Hewlett-Packard's LaserJet 4 reference manual.

#### Job control

Reset	ESC E
Number of copies	ESC &l#X
Universal exit language	ESC %#X
Long-edge (left) offset registration	ESC &l#U
Short-edge (right) offset registration	ESC &l#Z
Unit of measure	ESC &u#D
Simplex/Duplex print	ESC &l#S

#### Page control

Paper (Media) source	ESC &l#H
Page size	ESC &l#A
Paper Size Selection	ESC &q#G
Page length	ESC &l#P
Output (Media) bin	ESC &l#G
Orientation	ESC &l#O
Print direction	ESC &a#P
Top margin	ESC &l#E
Text length	ESC &l#F
Left margin	ESC &a#L
Right margin	ESC &a#M
Clear horizontal margins	ESC 9
Perforation skip	ESC &l#L
Horizontal Motion Index (HMI)	ESC &k#H
Vertical Motion Index (VMI)	ESC &l#C
Line spacing	ESC &l#D
Alphanumeric ID (Media selection by type only)	ESC &n#W[operation] [string]

#### Cursor positioning

Vertical position	ESC &a#R
	ESC *p#Y
	ESC &a#V



**Soft font creation**

Font descriptor	ESC )s#W[data]
Download character	ESC (s#W[data]
Character code	ESC *c#E

**Raster Graphics**

Raster resolutions	ESC *t#R
Raster graphics presentations	ESC *r#F
Start raster graphics	ESC *r#A
Raster Y offset	ESC *b#Y
Set raster compression mode	ESC *b#M
Transfer raster data by row	ESC *b#W[data]
End raster graphics (version B)	ESC *rB
End raster graphics (version C)	ESC *rC
Raster height	ESC *r#T
Raster width	ESC *r#S

**Print model**

Select current pattern	ESC *v#T
Select source transparency mode	ESC *v#N
Select pattern transparency mode	ESC *v#O
Rectangle width (PCL unit)	ESC *c#A
Rectangle width (decipoints)	ESC *c#H
Rectangle height (PCL unit)	ESC *c#B
Rectangle height (decipoints)	ESC *c#V
Fill rectangular area	ESC *cP



**User-defined pattern management/creation**

Pattern ID	ESC *c#G
Define pattern	ESC *c#W[data]
User-defined pattern control	ESC *c#Q
Set pattern reference point	ESC *p#R

**Macros**

Macro ID	ESC &f#Y
Macro control	ESC &f#X

Proof Sign-off:  
M.Takata  
K.Nishi  
K.Pipa

\_\_\_\_\_  
\_\_\_\_\_  
\_\_\_\_\_

## **Flamingo Rev. C**

A5 size  
7/16/98

APPCOMM.FM  
Pass 0

R

### **Vector Group**

Arc absolute	AA
Arc relative	AR
Absolute arc three point	AT
Bezier absolute	BZ
Bezier relative	BR
Plot absolute	PA
Plot relative	PR
Pen down	PD
Pen up	PU
Relative arc three point	RT
Polyline encoded	PE

### **Polygon Group**

Circle	CI
Fill rectangle absolute	RA
Fill rectangle relative	RR
Edge rectangle absolute	EA
Edge rectangle relative	ER
Fill wedge	WG
Edge wedge	EW
Polygon mode	PM
Fill polygon	FP
Edge polygon	EP

C

Proof Sign-off:  
M.Takata  
K.Nishi  
K.Pipa

\_\_\_\_\_  
\_\_\_\_\_  
\_\_\_\_\_

## Flamingo Rev. C

A5 size  
7/16/98

APPCOMM.FM  
Pass 0

R

---

### ESC/P 2 and FX Commands

This section lists the printer commands supported in the ESC/P 2 and FX emulation modes.

#### ESC/P 2 mode

##### General operation

Initialize printer	ESC @
Control paper loading/ejecting	ESC EM <i>n</i>

##### Paper feeding

Carriage return	CR
Form feed	FF
Line feed	LF
Select 1/8-inch line spacing	ESC 0
Select 1/6-inch line spacing	ESC 2
Set <i>n</i> /180-inch line spacing	ESC 3 <i>n</i>
Set <i>n</i> /360-inch line spacing	ESC + <i>n</i>

##### Page format

Set page format	ESC ( <i>c nn</i>
Set page length in defined units	ESC ( C <i>nn</i>
Set page length in lines	ESC C <i>n</i>
Set page length in inches	ESC C 0 <i>n</i>
Set bottom margin for continuous paper	ESC N <i>n</i>
Cancel top/bottom margin for continuous paper	ESC O
Set left margin	ESC I <i>n</i>
Set right margin	ESC Q <i>n</i>



### **Font enhancement**

Select condensed printing	SI
Cancel condensed printing	DC2
Select double-width printing (one line)	SO
Turn double-width printing on/off	ESC W 1/0
Cancel double-width printing (one line)	DC4
Turn double-height printing on/off	ESC w 1/0
Select double-strike printing	ESC G
Cancel double-strike printing	ESC H
Select superscript printing	ESC S 0
Select subscript printing	ESC S 1
Cancel superscript/subscript printing	ESC T
Select line/score	ESC ( - nn
Turn underline on/off	ESC - 1/0
Select character style	ESC q n

### **Spacing**

Set intercharacter space	ESC SP n
Define unit	ESC ( U nn

### **Character handling**

Assign character table	ESC ( t nn
Select character table	ESC t n
Select an international character set	ESC R n
Define download character	ESC & nn
Copy ROM to RAM	ESC : 0 n 0
Select user-defined set	ESC % n
Enable printing of upper control codes	ESC 6
Enable upper control codes	ESC 7
Print data as characters	ESC ( ^ nn



### **Bit image**

Selection and printing of bit image	ESC * nn
Select graphic mode	ESC ( G nn
Print raster graphics	ESC . c v hm

Proof Sign-off:  
M.Takata  
K.Nishi  
K.Pipa

# Flamingo Rev. C

A5 size  
7/16/98

APPCOMM.FM  
Pass 0

R

## Overall printing style

Select letter quality or draft ESC x n

*Note:*

*The print quality and speed cannot be changed even if you send the ESC x command.*

Select typeface family ESC k n  
Master select ESC ! n

## Print size and character width

Select 10 cpi	ESC P
Select 12 cpi	ESC M
Turn proportional mode on/off	ESC p 1/0
Select condensed mode	SI
Cancel condensed mode	DC2
Select double-width mode (one line)	SO
Cancel double-width mode (one line)	DC4
Turn double-width mode on/off	ESC W 1/0
Turn double-height printing on/off	ESC w 1/0

## Font enhancement

Select emphasized mode	ESC E
Cancel emphasized mode	ESC F
Select double-strike mode	ESC G
Cancel double-strike mode	ESC H

*Note:*

*The ESC G and ESC E commands produce identical effects; you cannot obtain darker print by combining the two.*

Select superscript/subscript mode	ESC S 0/1
Cancel superscript/subscript mode	ESC T
Select italic mode	ESC 4
Cancel italic mode	ESC 5
Turn underline mode on/off	ESC - 1/0





---

## **PJL Commands**

This section lists the available commands for printer job language mode (PJL). For more information on PJL, refer to the Printer Job Language Technical Reference Manual from Hewlett-Packard.

COMMENT	@PJL COMMENT [words] [<CR>] <LF>
DEFAULT	@PJL DEFAULT [LPARM: ***] variable = value [<CR>] <LF>
DINQUIRE	@PJL DINQUIRE [LPARM: ***] variable [<CR>] <LF>
ECHO	@PJL ECHO [Words] [<CR>] <LF>
ENTER	@PJL ENTER LANGUAGE = *** [<CR>] <LF>
EOJ	@PJL EOJ [NAME= ***] [<CR>] <LF>
INFO	@PJL INFO read only variable [<CR>] <LF>
INITIALIZE	@PJL INITIALIZE [<CR>] <LF>
INQUIRE	@PJL INQUIRE [LPARM: ***] variable [<CR>] <LF>
JOB	@PJL JOB [NAME = ***][START = ***][END = ***][<CR>] <LF>
OPMSG	@PJL OPMSG DISPLAY = *** [<CR>] <LF>
RDYMSG	@PJL RDYMSG DISPLAY = *** [<CR>] <LF>
RESET	@PJL RESET [<CR>] <LF>
SET	@PJL SET [LPARM: ***] variable = value [<CR>] <LF>
STMSG	@PJL STMSG DISPLAY = *** [<CR>] <LF>
UEL	<ESC>%-12345X
USTATUS	@PJL USTATUS variable = value [<CR>] <LF>
USTATUSOFF	@PJL USTATUSOFF [<CR>] <LF>
PJL	@PJL [<CR>] <LF>



Proof Sign-off:  
M.Takata  
K.Nishi  
K.Pipa

\_\_\_\_\_  
\_\_\_\_\_  
\_\_\_\_\_

## Flamingo Rev. C

A5 size  
7/16/98

APPCOMM.FM  
Pass 0

R

### **Paper feeding/print position motion**

Carriage return	CR
Line feed	LF
Form feed	FF
Move paper vertically (n/180, n/216, or n/360 inch)	ESC J
Automatic line feed	ESC 5
Reverse line feed	ESC J
Back space	BS
Space	SP
Horizontal tab	HT
Vertical tab	VT
Move current print position (1/120 inch)	ESC d
Set top of form	ESC 4

### **Text**

#### **Font selection**

Select 10 pitch font	DC2
Select 12 pitch font	ESC:
Start 17 cpi printing	SI
Start 17 cpi printing	ESC SI
Proportional spacing	ESC P
Begin subscript/superscript	ESC S
End subscript/superscript	ESC T
Select font and pitch	ESC[I
Select print or font	ESC I
Select character set 2	ESC 6
Select character set 1	ESC 7
Select page code	ESC[T
Print one character	ESC ^
Print character from A Code Page	ESC \
Select character quality	ESC[d



Proof Sign-off:  
M.Takata  
K.Nishi  
K.Pipa

\_\_\_\_\_  
\_\_\_\_\_  
\_\_\_\_\_

## **Flamingo Rev. C**

A5 size  
7/16/98

APPCOMM.FM  
Pass 0

R

### **AGM mode**

#### **Line spacing**

Set line spacing for graphics (n/180, n/216, or n/360 inch)	ESC 3
Set line spacing for text (n/60 inch)	ESC A

#### **Paper feeding/print position motion**

Move paper vertically (n/180, n/216, or n/360 inch)	ESC J
Line feed	LF

#### **Bit image**

Normal-density bit image graphics	ESC K
Double-density bit image graphics (half speed)	ESC L
Double-density bit image graphics (normal speed)	ESC Y
High-density bit image graphics	ESC Z
Graphic print mode	ESC [g
Select graphic mode	ESC *



Proof Sign-off:  
M.Takata  
K.Nishi  
K.Pipa

\_\_\_\_\_  
\_\_\_\_\_  
\_\_\_\_\_

**Flamingo  
Rev. C**

A5 size  
7/16/98

APPFONT.FM  
Pass 0

R

---

*Appendix D*

---

***Working with Fonts***

Printer and Screen Fonts ..... D-2

Available Fonts ..... D-3

Adding More Fonts ..... D-6

    Downloading fonts ..... D-6

Selecting Fonts ..... D-6

**D**

Proof Sign-off:  
M.Takata  
K.Nishi  
K.Pipa

\_\_\_\_\_  
\_\_\_\_\_  
\_\_\_\_\_

## Flamingo Rev. C

A5 size  
7/16/98

APPFONT.FM  
Pass 0

R

### Available Fonts

The following table lists the fonts that are installed on your printer. The names of all the fonts appear in your software's font list if you are using the driver provided with the printer. (If you are using a different driver, all of these fonts may not be available.)

The fonts provided with the printer are shown in the following table.

#### LJ4/GL2 mode

Font name	Scalable font	HP equivalent
Dutch 801 SWC	Roman, Bold, Italic, Bold Italic	CG Times
Zapf Humanist 601 SWC	Demi, Bold, Demi Italic, Bold Italic	CG Omega

Font name	Bitmap font	HP equivalent
Line Printer	-	Line Printer
OCR A	-	-
OCR B	-	-
Code 3-9	-	-
EAN/UPC	Bold	-

When selecting fonts in your software program, choose the font name listed in the HP equivalent column.

D

Proof Sign-off:  
M.Takata  
K.Nishi  
K.Pipa

\_\_\_\_\_  
\_\_\_\_\_  
\_\_\_\_\_

**Flamingo  
Rev. C**

A5 size  
7/16/98

APPFONT.FM  
Pass 0

R

**1239X mode**

Font name	Scalable font
EPSON Sans serif	-
Courier SWC	Medium, Bold
EPSON Prestige	-
EPSON Gothic	-
EPSON Presentor	-
EPSON Orator	-
EPSON Script	-

Font name	Bitmap font
OCR B	-

To see the font samples, use the Test Menu in SelectType.

1. Make sure that paper is loaded.
2. Press Menu while the printer is on line.
3. Press Item until the font sample you want appears.
4. Press Enter, a Font Sample sheet is printed.



Proof Sign-off:  
M.Takata  
K.Nishi  
K.Pipa

\_\_\_\_\_  
\_\_\_\_\_  
\_\_\_\_\_

**Flamingo**  
**Rev. C**

A5 size  
7/16/98

APPMAP.FM  
Pass 0

R

*Appendix E*

---

***Map of SelecType Menus***

Switching between SelecType Menus ..... E-2

**E**

Proof Sign-off:  
M.Takata  
K.Nishi  
K.Pipa

\_\_\_\_\_  
\_\_\_\_\_  
\_\_\_\_\_

**Flamingo**  
**Rev. C**

A5 size  
7/16/98

APPMAP.FM  
Pass 0

R

**E**





---

## Glossary

### **ASCII**

American Standard Code for Information Interchange. A standardized way of assigning codes to characters and control codes. The system is widely used by manufacturers of computers, printers, and software.

### **auto line feed**

A printer feature in which each carriage return code (CR) is automatically accompanied by a line feed (LF) code.

### **bitmap font**

The dot-by-dot representation of a font. Bitmap fonts are displayed on computer screens and printed on dot matrix printers. See *outline font*.

### **buffer**

See *memory*.

### **character set**

A collection of letters, numbers, and symbols used in a particular language.

### **cpi (characters per inch)**

A measure of the size of fixed-width text characters.

### **default**

A value or setting that takes effect when the printer is turned on, reset, or initialized.

### **dots per inch (dpi)**

The number of dots per inch is a measure of printer resolution. The higher the number of dots, the higher the resolution.

### **download**

To transfer information from the computer to the printer.

### **download font**

A font that is loaded into the printer's memory from an outside source, such as a computer. Also called soft font.

### **dpi**

See *dots per inch*.

### **driver**

The part of a software program that converts commands from the program into commands used by the printer. Also known as the printer driver.

### **drum**

The part of the printer mechanism where the image is formed and transferred to the paper.



**PCL**

The command language built into the Hewlett-Packard LaserJet series printers.

**photoconductor unit**

A component of the printer that contains a photosensitive print drum.

**pitch**

A measure of the number of *characters per inch* (cpi) for fixed-width fonts.

**point size**

The height of a particular font as measured from the top of the tallest character to the bottom of the lowest. A point is a typographic unit of measure equivalent to 1/72 of an inch.

**portrait**

Printing that is oriented upright on the page (as opposed to landscape, in which printing is oriented sideways on the page). This is the standard orientation for printing letters or documents.

**printer driver**

See *driver*.

**printer emulation**

A set of operating commands that determines how data sent from the computer is interpreted and acted upon. Printer emulations replicate existing printers, such as the HP LaserJet 4.

**proportional font**

A font whose characters have varying amounts of horizontal space depending on the width of the character. Thus the uppercase M takes up more horizontal space than the lowercase l.

**RAM**

Random Access Memory (RAM) is where temporary information is stored.

**reset**

To refresh the printer's memory and erase the current print jobs.

**resident font**

A font that is stored permanently in the printer's memory.

**resolution**

A measure of the fineness and clarity of images produced by the printer or monitor. Printer resolution is measured in dots per inch. Monitor resolution is measured in pixels.

**RItech**

Resolution Improvement Technology. A feature that smooths the jagged edges of printed lines or shapes.

**ROM**

Read Only Memory (ROM) is where permanent information is stored.



L

**Flamingo  
Rev. C**

A5 size  
7/16/98

GLOSSARY.FM  
Pass 0

Proof Sign-off:  
M.Takata  
K.Nishi  
K.Pipa

\_\_\_\_\_  
\_\_\_\_\_  
\_\_\_\_\_

***sans serif font***

A font lacking serifs.

***scalable font***

See *outline font*.

***SelectType***

A feature of the printer that allows you to set printer values and control most of the printer's functions from the control panel.

***serif***

The small decorative strokes that come off the main lines of a character.

***status sheet***

A report that lists the printer settings and other printer information.

***symbol set***

A collection of symbols and special characters. Symbols are assigned to specific codes in a character table.

***TrueType***

An outline font format that was developed jointly by Apple Computer and Microsoft Corporation. TrueType fonts are outline fonts that can be easily resized for screen display or for printing.

**emulation**

See *printer emulation*.

**fixed-width font**

A font whose characters are allotted the same amount of horizontal space, no matter the width of the character. Thus the uppercase M receives the same amount of space as the letter l.

**font**

A set of characters and symbols that share a common typographic design and style.

**font family**

The collection of all sizes and styles of a font.

**halftone**

A grayscale image that is composed of small dots. The dots can be close together to create black or more widely spaced to create gray or white areas in the image. Newspaper photographs are common examples of halftones.

**imaging cartridge**

The imaging cartridge contains a photosensitive print drum and a supply of toner.

**initialization**

The act of returning the printer to its defaults (fixed set of conditions).

**interface**

The connection between the printer and the computer. A parallel interface transmits data one character or code at a time, and a serial interface transmits data one bit at a time.

**landscape**

Printing that is oriented sideways on the page. This orientation gives you a page that is wider than it is high and is useful for printing spreadsheets.

**memory**

The part of the printer's electronic system that is used to store information. Some information is fixed and is used to control how the printer operates. Information that is sent to the printer from the computer (such as downloaded fonts) is stored in memory temporarily. See also *RAM* and *ROM*.

**orientation**

Refers to the direction in which characters are printed on a page. This direction is either portrait, like this page, or landscape with the text printed on a page turned sideways.

**outline font**

A font whose outline is described mathematically, allowing it to be rendered (printed or drawn) smoothly at any size.

L

**Flamingo  
Rev. C**

A5 size  
7/16/98

APPMAP.FM  
Pass 0

Proof Sign-off:  
M.Takata  
K.Nishi  
K.Pipa

\_\_\_\_\_  
\_\_\_\_\_  
\_\_\_\_\_

L

**Flamingo  
Rev. C**

A5 size  
7/16/98

APPMAP.FM  
Pass 0

Proof Sign-off:

M.Takata

K.Nishi

K.Pipa

\_\_\_\_\_  
\_\_\_\_\_  
\_\_\_\_\_

---

### ***Switching between SelectType Menus***

The following menu maps show the possible menus and options in SelectType.

**KEY**

- ▷ Pressing the Menu button displays the next menu.
- ◁ Pressing the Alt + Menu buttons displays the prior menu.
- ( ) This is only available with option.

L

**Flamingo  
Rev. C**

A5 size  
7/16/98

APPFONT.FM  
Pass 0

Proof Sign-off:  
M.Takata \_\_\_\_\_  
K.Nishi \_\_\_\_\_  
K.Pipa \_\_\_\_\_

---

## **Adding More Fonts**

Fonts that reside on your computer's hard disk can be downloaded, or transferred, to the printer so they can be printed. Downloaded fonts, also called soft fonts, remain in printer memory until you turn off the printer or otherwise reinitialize it. If you plan on downloading many fonts, make sure your printer has sufficient memory.

### **Downloading fonts**

Most font packages make it easy to install fonts by providing their own installer. The installer gives you the option of having the fonts automatically downloaded whenever you start your computer or having fonts downloaded only when you need to print a particular font.

If you're running Windows, you can also install fonts from within the Fonts window. (To access this window, open the Control Panel and click the Fonts icon.) Once installed, the fonts are available in all your Windows applications.

---

## **Selecting Fonts**

Whenever possible select fonts from the font list in your software application. See your software documentation for instructions.

If you are sending unformatted text to the printer directly from DOS or if you are using a simple software package that does not include font selection, you can select fonts with SelecType when in the LJ4, ESCP2, FX, or I239X menu.



L

**Flamingo  
Rev. C**

A5 size  
7/16/98

APPFONT.FM  
Pass 0

Proof Sign-off:

M.Takata

K.Nishi

K.Pipa

\_\_\_\_\_  
\_\_\_\_\_  
\_\_\_\_\_

**ESC/P 2 and FX modes**

Font name	Scalable font
EPSON Roman	-
EPSON Sans serif	-
Courier SWC	Medium, Bold
EPSON Prestige	-
EPSON Script	-
Swiss 721 SWM*	Roman, Bold
Dutch 801 SWM*	Roman, Bold
Letter Gothic SWC	Roman, Bold

\* Available only in ESC/P 2 mode.

Font name	Bitmap font
OCR A	
OCR B	

Read this section if you would like to know more about fonts or see samples of the installed fonts.

To select a font, use your application program.

Font problems are uncommon but the following may occur.

- The printer substitutes a font other than the one you selected with your software.
- The printed page does not exactly match what is on screen.

These kinds of problems usually occur if you use an emulation other than LJ4 or when you are trying to print fonts that are not installed in the printer. If you have font problems, read "Printer and Screen Fonts" below to find out how to fix them.

---

### **Printer and Screen Fonts**

Fonts are installed on both the printer and the computer. The printer fonts, which reside in printer memory, are used by the printer to print text. Screen fonts, which are stored in your computer, are used to display text on screen to represent the fonts that will be printed.

Two separate sets of fonts are needed because the monitor and printer have different requirements for producing fonts. The monitor normally uses bitmap fonts that are specially designed for the screen's resolution. A bitmap is a dot-by-dot representation of an image or character. The printer, however, uses an outline font that is created from a mathematical formula that describes the outline of each character. Using outline fonts allows the printer to render any character in the requested size.



**Note:**

*The distinction between printer and screen fonts is not as important when you are using TrueType fonts, which are included with Windows. TrueType is an outline font format that can be used by both the printer and the screen.*

L

**Flamingo**  
**Rev. C**

A5 size  
7/16/98

APPCOMM.FM  
Pass 0

Proof Sign-off:  
M.Takata  
K.Nishi  
K.Pipa

\_\_\_\_\_  
\_\_\_\_\_  
\_\_\_\_\_

L

**Flamingo  
Rev. C**

A5 size  
7/16/98

APPCOMM.FM  
Pass 0

Proof Sign-off:  
M.Takata  
K.Nishi  
K.Pipa

\_\_\_\_\_  
\_\_\_\_\_  
\_\_\_\_\_

**Font enhancement**

Continuous overscore	ESC _
Continuous underline	ESC -
Score select	ESC [-
Select print type style	ESC [@
Begin double-width printing by line	SO
Begin double-width printing by line	ESC SO
End double-width printing by line	DC4
Double-width printing	ESC W
Begin emphasized (bold) print	ESC E
End emphasized (bold) print	ESC F
Begin double-strike print	ESC G
End double-strike print	ESC H

**Bit image**

Normal-density bit image graphics	ESC K
Double-density bit image graphics (half speed)	ESC L
Double-density bit image graphics (normal speed)	ESC Y
High-density bit image graphics	ESC Z
Graphic print mode	ESC [g

**Bar code**

Bar code set up	ESC [f
Bar code transfer	ESC [P-

**Auxiliary functions**

**Initialize**

Set initial conditions	ESC [K
------------------------	--------

**Data input control**

Cancel 1 line	CAN
---------------	-----

**Auxiliary function**

Select paper tray	ESC [F
-------------------	--------

---

**I239X Emulation Commands**

This section lists the printer commands supported in the I239X emulation mode. For more information on these commands, see IBM's 2390/2391 reference manual.

**Page format****Printable area**

Set page length in lines	ESC C n
Set page length in inches	ESC C NUL n
Set skip perforation	ESC N n
Cancel skip perforation	ESC O
Set horizontal margins	ESC X

**Line spacing**

Set line space to 1/8 inch	ESC 0
Set line space to 7/72 inch	ESC 1
Activate line spacing for text	ESC 2
Set line spacing for graphics (n/180, n/216, or n/360 inch)	ESC 3 n
Set line spacing for text (n/72 inch)	ESC A n

**Unit definition**

Set vertical units (1/180, 1/216, or 1/360 inch)	ESC [ \
---	---------

**Tab**

Set vertical tab stops	ESC B
Set default tab stops	ESC R
Set horizontal tab stops	ESC D

L

**Flamingo  
Rev. C**

A5 size  
7/16/98

APPCOMM.FM  
Pass 0

Proof Sign-off:  
M.Takata  
K.Nishi  
K.Pipa

\_\_\_\_\_  
\_\_\_\_\_  
\_\_\_\_\_

**Word processing**

Set intercharacter space  
Select character tables  
Assign character tables  
Select international character set  
Printable code area expansion  
Enable upper control codes

ESC SP *n*  
ESC t *n*  
ESC ( t *nn*  
ESC R *n*  
ESC 6  
ESC 7

**User Defined Characters**

Define user-defined characters

ESC & *nn*

**Note:**

*The appearance of characters defined using ESC & may differ slightly from an actual FX printer.*

Copy ROM to RAM  
Select user-defined set  
Printable code area expansion

ESC : 0 *n* 0  
ESC % *n*  
ESC I *n*

**Bit image**

Select graphics mode  
Selection and printing of bit image

ESC \* *m n*  
ESC ^ *m n*

## FX mode

### Printer commands arranged by topic

The following section lists and describes all FX and LQ commands by topic.

#### Printer operation

Initialize printer	ESC @
Control paper loading/ejecting	ESC EM <i>n</i>

#### Data control

Carriage return	CR
-----------------	----

#### Vertical motion

Form feed	FF
Set page length in lines	ESC C <i>n</i>
Set page length in inches	ESC C 0 <i>n</i>
Set skip over perforation	ESC N <i>n</i>
Cancel skip over perforation	ESC O
Line feed	LF
Select 1/8-inch line spacing	ESC 0
Select 7/72-inch line spacing	ESC 1
Select 1/6-inch line spacing	ESC 2
Select <i>n</i> /216-inch line spacing	ESC 3 <i>n</i>
Perform <i>n</i> /216-inch line spacing	ESC J
Tab vertically	VT
Set vertical tabs	ESC B <i>nn</i>

#### Note:

Your printer will not print characters beyond one page length (set with the ESC C or ESC C 0 commands), while an FX printer might print them.

#### Horizontal motion

Set absolute horizontal print position	ESC \$ <i>n1 n2</i>
Set relative horizontal print position	ESC \ <i>n1 n2</i>
Set left margin	ESC l <i>n</i>
Set right margin	ESC Q <i>n</i>
Tab horizontally	HT
Set horizontal tabs	ESC D <i>nn</i>

L

**Flamingo  
Rev. C**

A5 size  
7/16/98

APPCOMM.FM  
Pass 0

Proof Sign-off:  
M.Takata  
K.Nishi  
K.Pipa

\_\_\_\_\_  
\_\_\_\_\_  
\_\_\_\_\_

**Print position motion**

Set absolute horizontal print position	ESC \$ n1 n2
Set relative horizontal print position	ESC \ n1 n2
Set absolute vertical print position	ESC ( V nn
Set relative vertical print position	ESC ( v nn
Set horizontal tabs	ESC D nn
Tab horizontally	HT
Set vertical tabs	ESC B nn
Tab vertically	VT
Advance paper n/180 inch	ESC J n
Reverse paper n/180 inch	ESC j n

**Font selection**

Select typeface	ESC k n
Select font by pitch and point	ESC X nn
Select 10.5 point, 10 cpi	ESC P
Select 10.5 point, 12 cpi	ESC M
Select 10.5 point, 15 cpi	ESC g
Turn proportional mode on/off	ESC p 1/0
Select LQ or draft	ESC x n
Select italic font	ESC 4
Cancel italic font	ESC 5
Select bold font	ESC E
Cancel bold font	ESC F
Master select	ESC ! n
Control code set/clear	ESC I 1/0
Select print pitch	ESC c



**Character Group**

Select standard font	SS
Select alternate font	SA
Absolute direction	DI
Relative direction	DR
Absolute character size	SI
Relative character size	SR
Character slant	SL
Extra space	ES
Standard font definition	SD
Alternate font definition	AD
Character fill mode	CF
Label origin	LO
Label	LB
Define label terminator	DT
Character plot	CP
Transparent data	TD
Define variable text path	DV

**Line and fill attribute group**

Line type	LT
Line attribute	LA
Pen width	PW
Pen width unit selection	WU
Select pen	SP
Symbol mode	SM
Fill type	FT
Anchor corner	AC
Raster fill definition	RF
User defined line type	UL

**Configuration and status group**

Scale	SC
Input window	IW
Input P1 and P2	IP
Input relative P1 and P2	IR
Default values	DF
Initialize	IN
Rotate coordinate system	RO
Comment	CO

L

**Flamingo  
Rev. C**

A5 size  
7/16/98

APPCOMM.FM  
Pass 0

Proof Sign-off:  
M.Takata  
K.Nishi  
K.Pipa

\_\_\_\_\_  
\_\_\_\_\_  
\_\_\_\_\_

**Status readback**

Set status readback location type	ESC *s#T
Set status readback location unit	ESC *s#U
Inquire status readback entity	ESC *s#I
Flush all pages	ESC &tr#F
Free memory space	ESC *s1M
Echo	ESC *s#X

**Programming hints**

End-of-line wrap	ESC &cs#C
Enable display functions	ESC Y
Disable display functions	ESC Z

**PCL vector graphics switching / set-up picture frame**

Enter GL/2 mode	ESC %#B
GL/2 plot horizontal size	ESC*c#K
GL/2 plot vertical size	ESC*c#L
Set picture frame anchor point	ESC*c0T
Picture frame horizontal size	ESC*c#X
Picture frame vertical size	ESC*c#Y

**GL/2 context commands**

**Dual context extensions**

Enter PCL mode	ESC %#A
Reset	ESC E
Primary font	FI
Secondary font	FN
Scalable or bitmapped fonts	SB

**Palette extensions**

Transparency mode	TR
Screened vectors	SV
Number of pens	NP

L

**Flamingo  
Rev. C**

A5 size  
7/16/98

APPCOMM.FM  
Pass 0

Proof Sign-off:  
M.Takata  
K.Nishi  
K.Pipa

\_\_\_\_\_  
\_\_\_\_\_  
\_\_\_\_\_

Horizontal position

ESC &a#C  
ESC \*p#X  
ESC &a#H

Half line feed

ESC =

Line termination  
Push/pop position

ESC &k#G  
ESC &f#S

**Font selection**

Primary symbol set	ESC (id
Secondary symbol set	ESC )id
Primary spacing	ESC (s#P
Secondary spacing	ESC )s#P
Primary pitch	ESC (s#H
Secondary pitch	ESC )s#H
Set pitch mode	ESC &k#S
Primary height	ESC (s#V
Secondary height	ESC )s#V
Primary style	ESC (s#S
Secondary style	ESC )s#S
Primary font stroke weight	ESC (s#B
Secondary font stroke weight	ESC )s#B
Primary typeface family	ESC (s#T
Secondary typeface family	ESC )s#T
Primary font default	ESC (3@
Secondary font default	ESC )3@
Enable underline	ESC &d#D
Disable underline	ESC &d@
Transparent print data	ESC &p#X[data]

**Font management**

Assign font ID	ESC *c#D
Font and character control	ESC *c#F
Set symbol set	ESC *c#R
Define symbol set	ESC (f#W[data]
Symbol set control	ESC *c#S
Select primary font with ID#	ESC (#X
Select secondary font with ID#	ESC )#X

L

**Flamingo  
Rev. C**

A5 size  
7/16/98

APPCOMM.FM  
Pass 0

Proof Sign-off:  
M.Takata  
K.Nishi  
K.Pipa

\_\_\_\_\_  
\_\_\_\_\_  
\_\_\_\_\_

Your printer has the ability to emulate the following printers depending on the printer emulation mode:

LJ-4	Hewlett-Packard LaserJet 4 (PCL5e)
ESC/P2	EPSON LQ-570 (24-pin)
FX	EPSON FX-870/1170, or LX-100 (9-pin)
GL/2	Hewlett-Packard GL/2 graphics language

In addition, the following printer control languages are supported:

PJL	Printer Job Language
EJL	EPSON Job Control Language

This appendix lists the printer commands for these modes. Most of the commands closely emulate the original printer or the control language; however, some have operational differences because the printers use different technologies. Additional information is provided in the descriptions of control commands with these differences.

For more information on emulation modes, refer to the following sections.

“Emulation Menu” on page 4-7

Appendix B, “Symbol Sets”

L

**Flamingo  
Rev. C**

A5 size  
7/16/98

APPSYM.FM  
Pass 0

Proof Sign-off:

M.Takata

K.Nishi

K.Pipa

\_\_\_\_\_  
\_\_\_\_\_  
\_\_\_\_\_

---

***In I239X Emulation Mode***

Available symbol sets in I239X mode are PC437, PC850, PC860, PC863, and PC865.

See "In ESC/P 2 or FX Modes" on page B-22.

Available fonts are EPSON Sans Serif, Courier SWC, EPSON Prestige, EPSON Gothic, EPSON Presentor, EPSON Orator, and EPSON Script.

---

***In EPSON GL/2 Mode***

Available symbol sets in EPSON GL/2 mode are the same as those in LaserJet 4 emulation mode. Refer to the section on LaserJet 4 mode.

L

**Flamingo  
Rev. C**

A5 size  
7/16/98

APPSYM.FM  
Pass 0

Proof Sign-off:

M.Takata

K.Nishi

K.Pipa

\_\_\_\_\_  
\_\_\_\_\_  
\_\_\_\_\_

**International character sets**

You can select one of the following international character sets using either SelecType or the ESC R command. For example, when you select "Italic France" in SelecType, the characters in the "France" row in the table below are used in the italic character table.

Country	ASCII code hex											
	23	24	40	5B	5C	5D	5E	60	7B	7C	7D	7E
USA												
France												
Germany												
UK												
Denmark												
Sweden												
Italy												
Spain												
Japan												
Norway												
Denmark II												
Spain II												
Latin America												
Korea*												
Legal*												

\* Available for ESC/P 2 emulation only

L

**Flamingo  
Rev. C**

A5 size  
7/16/98

APPSYM.FM  
Pass 0

Proof Sign-off:  
M.Takata  
K.Nishi  
K.Pipa

\_\_\_\_\_  
\_\_\_\_\_  
\_\_\_\_\_

*PC863 (Canadian-French)*

*PC865 (Norwegian)*

*PC857 (PcTurk2)*

*PC852 (East Europe)*





L

**Flamingo  
Rev. C**

A5 size  
7/16/98

APPSYM.FM  
Pass 0

Proof Sign-off:  
M.Takata  
K.Nishi  
K.Pipa

\_\_\_\_\_  
\_\_\_\_\_  
\_\_\_\_\_

**In ESC/P 2 or FX Modes**

	PC 437, 850, 860, 863, 865	857, 852, BRASCII, Abicamp	PC 437	OCR A
EPSON Roman	○	×	×	×
Courier SWC	○	○	×	×
EPSON Sans serif	○	×	×	×
EPSON Prestige	○	×	×	×
EPSON Script	○	×	×	×
Letter Gothic SWC	○	○	×	×
Swiss 721 SWM*	○	○	×	×
Dutch 801 SWM*	○	○	×	×
OCR B	×	×	○	×
OCR A	×	×	×	○

\*Available only in ESC/P 2 mode.

L

**Flamingo  
Rev. C**

A5 size  
7/16/98

APPSYM.FM  
Pass 0

Proof Sign-off:  
M.Takata  
K.Nishi  
K.Pipa

\_\_\_\_\_  
\_\_\_\_\_  
\_\_\_\_\_

*Code 3-9 (0Y)*

*EAN/UPC (8Y)*

L

**Flamingo  
Rev. C**

A5 size  
7/16/98

APPSYM.FM  
Pass 0

Proof Sign-off:  
M.Takata  
K.Nishi  
K.Pipa

\_\_\_\_\_  
\_\_\_\_\_  
\_\_\_\_\_

*Wingdings (579L)*

*OCR A (00)*

L

**Flamingo  
Rev. C**

A5 size  
7/16/98

APPSYM.FM  
Pass 0

Proof Sign-off:  
M.Takata  
K.Nishi  
K.Pipa

\_\_\_\_\_  
\_\_\_\_\_  
\_\_\_\_\_

*PiFont (15U)*

*PcE.Europe (17U)*

L

**Flamingo  
Rev. C**

A5 size  
7/16/98

APPSYM.FM  
Pass 0

Proof Sign-off:  
M.Takata  
K.Nishi  
K.Pipa

\_\_\_\_\_  
\_\_\_\_\_  
\_\_\_\_\_

**McText (12J)**

**PcMultilingual (12U)**

L

**Flamingo  
Rev. C**

A5 size  
7/16/98

APPSYM.FM  
Pass 0

Proof Sign-off:  
M.Takata  
K.Nishi  
K.Pipa

\_\_\_\_\_  
\_\_\_\_\_  
\_\_\_\_\_

**Windows (9U)**

**PsText (10J)**

L

**Flamingo  
Rev. C**

A5 size  
7/16/98

APPSYM.FM  
Pass 0

Proof Sign-off:

M.Takata

K.Nishi

K.Pipa

\_\_\_\_\_

\_\_\_\_\_

\_\_\_\_\_

*DeskTop (7J)*

*Math-8 (8M)*

L

**Flamingo  
Rev. C**

A5 size  
7/16/98

APPSYM.FM  
Pass 0

Proof Sign-off:  
M.Takata  
K.Nishi  
K.Pipa



**8859-9 ISO(5N)**

**WITurkish (5T)**



L

**Flamingo  
Rev. C**

A5 size  
7/16/98

APPSYM.FM  
Pass 0

Proof Sign-off:  
M.Takata  
K.Nishi  
K.Pipa

\_\_\_\_\_  
\_\_\_\_\_  
\_\_\_\_\_

ECM94-1 (0N)

\*Legal (1U)

L

**Flamingo  
Rev. C**

A5 size  
7/16/98

APPSYM.FM  
Pass 0

Proof Sign-off:  
M.Takata  
K.Nishi  
K.Pipa

\_\_\_\_\_  
\_\_\_\_\_  
\_\_\_\_\_

The 35 and 43 typefaces refer to those shown in the table below:

	Typefaces	
	35	43
Flareserif 821 SWC	○	○
Incised 901 SWC	○	○
Clarendon Condensed SWC	○	○
Ribbon 131 SWC	○	○
Original Garamond SWC	○	○
Audrey Two SWC	○	○
Zapf Humanist 601 SWC	○	○
Swiss 742 Condensed SWC	○	○
Swiss 721 SWM	-	○
Dutch 801 SWM	-	○
Courier SWC	○	○
Letter Gothic SWC	○	○
Dutch 801 SWC	○	○
Swiss 742 SWC	○	○

L

**Flamingo  
Rev. C**

A5 size  
7/16/98

APPSYM.FM  
Pass 0

Proof Sign-off:

M.Takata

K.Nishi

K.Pipa

\_\_\_\_\_  
\_\_\_\_\_  
\_\_\_\_\_

---

## **Introduction to Symbol Sets**

Your printer can access a variety of symbol sets. Many of these symbol sets differ only in the international characters specific to each language.

**Note:**

*Normally, your software handles fonts and symbols, so you probably never need to adjust the printer's settings. If you are writing your own printer control programs, or if you are using older software that cannot control fonts, refer to the following sections for symbol set details.*

When you are considering which font to use, you should also consider which symbol set to combine with the font. Available symbol sets vary depending on which emulation mode you use and which font you choose.

L

**Flamingo**  
**Rev. C**

A5 size  
7/16/98

APPSPEC.FM  
Pass 0

Proof Sign-off:  
M.Takata  
K.Nishi  
K.Pipa

\_\_\_\_\_  
\_\_\_\_\_  
\_\_\_\_\_

L

**Flamingo  
Rev. C**

A5 size  
7/16/98

APPSPEC.FM  
Pass 0

Proof Sign-off:  
M.Takata  
K.Nishi  
K.Pipa

\_\_\_\_\_  
\_\_\_\_\_  
\_\_\_\_\_

Dimensions and weight:

Height	465 mm (18.3 inches)
Width	539 mm (21.2 inches)
Depth	590 mm (23.2 inches)
Weight	Unit 19.5 kg (43 lb) Brackets 4 kg (8.8 lb)

**Face-up Tray (C81306\*)**

Paper size:	A3, A4, Ledger, Legal, GLG, Letter, Executive
Paper capacity	Up to 200 sheets (75 g/m <sup>2</sup> or 20 lb paper)
Paper weight:	60 to 190 g/m <sup>2</sup> (27 to 86 lb)

Dimensions and weight:

Height	230 mm (9.1 inches)
Width	483 mm (19.0 inches)
Depth	340 mm (13.4 inches)
Weight	2.0 kg (4.4 lb)

**Envelope Feeder (C81307\*)**

Paper size:	Monarch, C10, DL, C5
AC power supply:	DC 5V and 24V supplied by the printer

Dimensions and weight:

Height	133 mm (5.2 inches)
Width	444 mm (17.5 inches)
Depth	278 mm (10.9 inches)
Weight	3 kg (6.6 lb)

L

**Flamingo  
Rev. C**

A5 size  
7/16/98

APPSPEC.FM  
Pass 0

Proof Sign-off:

M.Takata

K.Nishi

K.Pipa

\_\_\_\_\_  
\_\_\_\_\_  
\_\_\_\_\_

---

## **Options and Consumables**

### **Large Capacity Paper Unit (C81303\*)**

Paper size:	Lower Cassette 3: A3, A4, Ledger, Legal, GLG, Letter, Executive
	Lower Cassette 4 and 5: A4, Letter, Executive
Paper weight:	60 to 90 g/m <sup>2</sup> (16 to 24 lb)
Paper feed:	Automatic feed delivery system
Cassette capacity:	Lower Cassette 3: Up to 500 sheets (75 g/m <sup>2</sup> or 20 lb paper)
	Lower Cassette 4: Up to 1000 sheets (75 g/m <sup>2</sup> or 20 lb paper)
	Lower Cassette 5: Up to 1000 sheets (75 g/m <sup>2</sup> or 20 lb paper)
Feeding speed:	Lower Cassette 3: 11 seconds or less for the first A4 or Letter-size sheet; 38 pages per minute for subsequent A4 or Letter-size sheets
	Lower Cassette 4: 12 seconds or less for the first A4 or Letter-size sheet; 37 pages per minute for subsequent A4 or Letter-size sheets
	Lower Cassette 5: 13 seconds or less for the first A4 or Letter-size sheet; 35 pages per minute for subsequent A4 or Letter-size sheets
Paper types:	Plain paper, such as copier paper, and recycled paper Transparencies Labels
AC power supply:	DC 5V and 24V supplied by the printer

**NC**

Not used.

**PeripheralLogicHigh**Pull up to + 5 V with 3.9 k $\Omega$ .**nInit/nReverseRequest**

Compatibility mode:	When a low signal is detected, the printer is deemed to be BUSY until the low signal is released.
Negotiation phase:	Always high.
Reverse data transfer phase:	Always high.
ECP mode:	Low when switching to reverse direction. The peripheral device has permission to drive the data signal only when this signal is low and 1284 active is high.

**nFault/DataAvail/nPeriphRequest**

Compatibility mode:	Low signal indicates that an error occurred.
Negotiation phase:	This signal is set high in order to authorize 1284 compatibility. In nibble mode, after the host sets HostBusy (nAutoFd) high, this signal is set low in order to indicate that the transmission data is ready.
Reverse data transfer phase:	This signal is set low in order to indicate to a nibble mode host that the transmission data is ready. Afterwards, this signal serves as nibble data bit 0 and then 4.
Reverse final phase:	Indicates whether or not the data is valid.
ECP mode:	This signal is set low to request communications with the host. Valid in both forward and reverse direction.

L

**Flamingo  
Rev. C**

A5 size  
7/16/98

APPSPEC.FM  
Pass 0

Proof Sign-off:

M.Takata

K.Nishi

K.Pipa

\_\_\_\_\_  
\_\_\_\_\_  
\_\_\_\_\_

*Busy/PtrBusy/PeriphClk*

Compatibility mode:	High signal indicates that the printer is not ready to receive data.
Negotiation phase:	Reflects the BUSY status of the forward channel.
Reverse data transfer phase:	In nibble mode, this signal serves as nibble data bit 3 and then 7.
Reverse idle phase:	Reflects the BUSY status of the forward channel.
ECP mode:	Used for forward direction flow control. In reverse direction, this signal is used as a ninth data bit that indicates whether the data signals indicate a command or data.

*nError/AckDataReq/nAckReverse*

Compatibility mode:	High signal indicates that a feed jam occurred in the paper supply section, or that there is no paper in the paper tray.
Negotiation phase:	High signal indicates whether or not IEEE 1284 is supported or not. Afterwards, this signal conforms with nDataAvail (nFault).
Reverse data transfer phase:	In nibble mode, this signal serves as nibble data bit 2 and then 6.
Reverse final phase:	High until the host requests a data transfer. Afterwards, this signal conforms with nDataAvail (nFault).
ECP mode:	Low signal authorizes nReverseRequest. The host looks at this signal in order to determine whether or not it has permission to drive the data signals.



L

# Flamingo Rev. C

A5 size  
7/16/98

APPSPEC.FM  
Pass 0

Proof Sign-off:  
M.Takata  
K.Nishi  
K.Pipa

\_\_\_\_\_  
\_\_\_\_\_  
\_\_\_\_\_

Pin No.	Direction	IEEE 1284-B connector		
		Compatibility	Nibble	ECP
8	IN/OUT	DATA7		
9	IN/OUT	DATA8		
10	OUT	nACK	PtClk	PeriphClk
11	OUT	Busy	PrtBusy	PeriphAck
12	OUT	PError	AckDataReq	nAckReverse
13	OUT	Select	Xflag	
14	IN	nAutoFd	HostBusy	HostAck
15		NC		
16		GND		
17		CG		
18	OUT	PeripheralLogic High		
19 - 30		GND		
31	IN	nInit		nReverse Request
32	OUT	nFault	nDataAvail	nPeriphRequest
33		GND		
34		NC		
35	OUT	+5V		
36	IN	nSelectn	IEEE1284 Active	

L

**Flamingo  
Rev. C**

A5 size  
7/16/98

APPSPEC.FM  
Pass 0

Proof Sign-off:  
M.Takata  
K.Nishi  
K.Pipa

\_\_\_\_\_  
\_\_\_\_\_  
\_\_\_\_\_

Internal emulation: HP LaserJet4 emulation (LJ4 mode)  
HP-GL/2 emulation (GL2 mode)  
ESC/P 24-pin printer emulation (ESC/P 2 mode)  
ESC/P 9-pin printer emulation (FX mode)  
IBM Proprinter emulation (I239X mode)

Optional language: Adobe PostScript 3

Resident fonts: 45 scalable fonts, and one bitmap font (in LJ4 mode)

RAM: 16 MB, expandable up to 256 MB

**Environmental**

Temperature: Operation: 5 to 32°C (41 to 89°F)  
Storage: 0 to 35°C (32 to 95°F)

Humidity: Operation: 15 to 85% RH  
Storage: 15 to 85% RH

Altitude: 2,500 meters (8200 feet) maximum

**Mechanical**

Dimensions and weight: Height: 486 mm (19.1 inches)  
Width: 642 mm (25.3 inches)  
Depth: 523 mm (20.6 inches)  
Weight: Approx. 47 kg (103.6 lb) including the imaging cartridge

Durability: 5 years or 1,500,000 sheets, whichever comes first

---

**Paper Specifications****Note:**

*Since the quality of any particular brand or type of paper may be changed by the manufacturer at any time, EPSON cannot guarantee the quality of any type of paper. Always test samples of paper stock before purchasing large quantities or printing large jobs.*

**Paper Types:** Plain paper, recycled paper, labels, envelopes, transparencies, colored paper, card stock, letter head

**Note:**

*Use recycled paper under normal temperature and humidity conditions only. Poor quality paper may reduce print quality, cause paper jams and other problems.*

**Paper weight:**

Plain paper	60 to 90 g/m <sup>2</sup> , 16 to 24 lb
Card stock	90 to 190 g/m <sup>2</sup> , 24 to 50 lb

**Paper size:**

Paper	A3 (297 mm × 420 mm)
	A4 (210 mm × 297 mm)
	A5 (148 mm × 210 mm)
	Ledger (11 × 17 inches)
	Letter (8.5 × 11 inches)
	Half-Letter (5.5 × 8.5 inches)
	Legal (8.5 × 14 inches)
	Government Letter (8.5 × 10.5 inches)
	Government Legal (8.5 × 13 inches)
	Executive (7.25 × 10.5 inches)
	F4 (210 mm × 330 mm)
	Custom (100 × 148 mm ~ 297.4 × 431.8 mm)

**Envelopes:**

Monarch (3 7/8 × 7 1/2 inches)
Commercial 10 (4 1/8 × 9 1/2 inches)
DL (110 mm × 220 mm)
C5 (162 mm × 229 mm)
International B5 (176 mm × 250 mm)

**Caution:**

- Place the printer where you can easily unplug the power cord.
- Leave adequate room around the printer to allow for sufficient ventilation.
- Avoid locations that are subject to direct sunlight, excessive heat, moisture, or dust.
- Keep the entire computer and printer system away from potential sources of interference, such as loudspeakers or the base units of cordless telephones.
- Avoid using an electrical outlet that is controlled by wall switches or automatic timers. Accidental disruption of power can erase valuable information in the memory of your computer and printer.
- Avoid using outlets that other appliances are plugged into.
- Use a grounded outlet that matches the printer's power plug. Do not use an adapter plug.
- Only use an outlet that meets the power requirements for this printer.

### **Cleaning the printer case**

If the printer's outer case is dirty or dusty, turn off the printer and clean it with a soft, clean cloth dampened with a mild detergent.

**Caution:**

*Never use alcohol or thinner to clean the printer cover; these chemicals can damage the imaging cartridge, its components and the case. Be careful not to get water on the printer mechanism or any electronic components.*

### **Transporting the Printer**

If you need to transport your printer, carefully repack it using the original box and packing materials as follows.

1. Turn off the printer.
2. Open the printer cover and remove the imaging cartridge.

**Caution:**

- Whenever you ship or transport the printer, remove the imaging cartridge and place it in a plastic bag. Seal the bag to prevent the fine toner particles from spilling into the printer or onto your clothing.*
  - Do not expose the imaging cartridge to light any longer than necessary.*
3. Unplug the power cord from the electrical outlet; then disconnect any interface cables from the printer.
  4. Remove all installed options. See Chapter 3, "Options".
  5. Attach the protective materials to the printer; then repack the printer in its original box.

---

## **Resetting the Printer**

There are two ways to reset (return to a fixed set of conditions) the printer.

### **Reset**

Reset the settings for the emulation mode and interface you are using now by holding down ALT and Reset until *Reset* appears on the display. You can reset the printer anytime a printout is not being sent on the interface you are using.

### **Reset all**

Reset the settings for all emulation modes and interfaces by holding down ALT and Reset until *Reset All* appears on the display. You can also reset all emulation modes and interfaces by turning the printer off and back on.

### **Note:**

*Reset clears all print jobs received from all interfaces; be careful not to disrupt someone else's print job.*

---

## **Cleaning the Printer**

The printer needs only minimal cleaning. If you notice a decline in print quality, clean the inside of the printer as described in this section.

You should also clean the paper feeder and the printer cover every few months. These procedures are described later in this section.

Follow the steps below to clean the inside of the printer and the paper feeder.

### **Cleaning inside cover A**

1. Make sure the printer is turned off.

L

**Flamingo  
Rev. C**

A5 size  
7/16/98

TROUBLE.FM  
Pass 0

Proof Sign-off:

M.Takata

K.Nishi

K.Pipa

\_\_\_\_\_  
\_\_\_\_\_  
\_\_\_\_\_

---

## **Optimizing Print Quality**

Your printer provides you with a number of ways to print your documents to achieve the highest possible quality. The two features discussed here are EPSON's Resolution Improvement Technology (RITech) and Enhanced MicroGray (Enh. MG).

### **Resolution Improvement Technology**

Resolution Improvement Technology (RITech) is EPSON's original printer technology that improves the appearance of printed lines, text and graphics.

The factory default setting for RITech is On. RITech produces the best quality text and graphics for nearly all purposes. However, if you are printing gray shading or screen patterns, change the setting to Off.

To change the RITech setting, follow these steps:

#### **Using the printer driver:**

Select or clear the RITech check box on the Panel menu in the printer driver to turn RITech on or off.

#### **Using the SelecType:**

Follow the instructions in the section on using SelecType. This setting is made in the Config Menu (see "Config Menu" on page 4-12).

### **Adjusting print density**

Changing the print density affects all text and graphics; avoid making unnecessary changes. When making changes, check the new settings by printing several pages with various kinds of text and graphics.

If your printouts are too light or too dark, adjust the print density with the printer driver or by using SelecType.

7. Holding the grip and the tab on the imaging cartridge, insert it into the printer until it is housed completely.

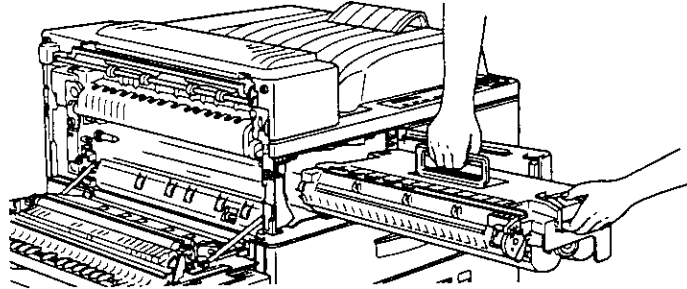

8. Make sure the tab is pushed down and flush with the imaging cartridge. Otherwise, you cannot close the front cover or cover A.

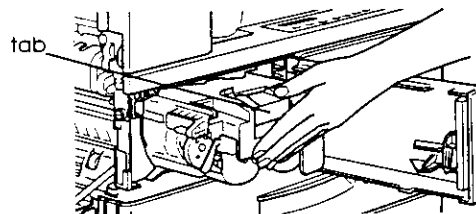

9. Slowly pull the clear seal all the way out with firm, even force.

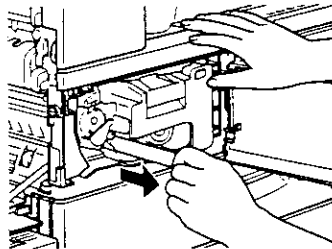



L

**Flamingo  
Rev. C**

A5 size  
7/16/98

TROUBLE.FM  
Pass 0

Proof Sign-off:

M.Takata

K.Nishi

K.Pipa

\_\_\_\_\_  
\_\_\_\_\_  
\_\_\_\_\_

---

## Replacing the Imaging Cartridge

The imaging cartridge prints up to 20,000 pages depending upon the complexity of your print jobs.

If your printed images become faint, enter the SelecType Setup menu and use the Toner function to find out approximately how much toner remains in the imaging cartridge.

Simply count the asterisks between the E (empty) and the F (full) on the display. Each asterisk represents about 25% of the total toner capacity. If you see only one asterisk on the display indicating that there is less than 25% toner left, prepare a replacement imaging cartridge.

Replace the cartridge with the S051060 imaging cartridge even if the cartridge you remove has a different part number. Order the S051060 cartridge that is specially designed for your high-quality 600-dpi printer.

1. Make sure the printer is turned off.
2. Gently open the printer cover. Remove the imaging cartridge by pulling the tab on the front of the cartridge up and toward you.
3. Dispose of the used imaging cartridge as a nonburnable item.



**Warning:**

*Do not dispose of used imaging cartridges in fire, as they can explode and cause injury. Dispose of them according to local regulations.*



**Caution:**

*Do not turn the imaging cartridge upside down. Do not expose the imaging cartridge to light any longer than necessary.*

L

**Flamingo**  
**Rev. C**

A5 size  
7/16/98

TROUBLE.FM  
Pass 0

Proof Sign-off:

M.Takata

K.Nishi

K.Pipa

\_\_\_\_\_  
\_\_\_\_\_  
\_\_\_\_\_

---

**Service Req yyyy**

---

A controller error or a print engine error has been detected. Write down the error number listed on the display and turn off the printer. Wait at least five seconds and then turn it back on. If the error message still appears, turn off the printer, unplug the power cord, and contact a qualified service person.

---

**Standby**

---

The printer is in its low power state; however, it is still on line if the On Line light is on.

---

**Toner Low**

---

The printer is almost out of toner. Prepare a new imaging cartridge to replace the current one with.

---

**Toner Out**

---

You must replace the imaging cartridge. See "Replacing the Imaging Cartridge" on page 5-34.

Press Continue to print one more page.

---

**Warming Up**

---

The printer is warming up.

L

**Flamingo  
Rev. C**

A5 size  
7/16/98

TROUBLE.FM  
Pass 0

Proof Sign-off:  
M.Takata \_\_\_\_\_  
K.Nishi \_\_\_\_\_  
K.Pipa \_\_\_\_\_

---

---

**Paper Out xxx yyy**

There is no paper in the specified paper source (xxx). Load paper of the indicated size (yyy) into the paper source. See Chapter 1, "Printing with the EPL-N4000" for instructions on loading paper.

---

---

**Paper Set xxx yyy**

The paper loaded in the paper source (xxx) does not match the required paper size (yyy). Replace the paper with the correct size of paper and press Continue.

---

---

**Print Overrun**

The time required to process data exceeds the print engine speed because the volume of data is too great. Press Continue to resume printing. If this message appears again, change the Page Protect setting in SelecType Config Menu.

---

---

**Ready**

The printer is ready to receive data and print.

---

---

**Reset**

The printer's current interface has been reset and the buffer is cleared. However, other interfaces are still active and retain their settings and data.

---

---

**Reset All**

All printer settings have been reset to the user default configuration, or the last settings that were saved.

---

**LC<x> Irregular Size**

---

You selected a paper size which is unavailable in lower cassette x (1 to 5). Change the paper size or paper source to continue the print job.

---

**LC<x> Error #<yyy>**

---

An error occurred with the lower cassette x (1 to 5).

Reset the printer by pressing the Continue and SelectType buttons simultaneously, or by turning off the printer, waiting 5 seconds, then turning it back on.

If the message still appears, contact your dealer or a qualified service person.

---

**Manual Feed xxx yyy**

---

Manual Feed mode is specified for the current print job. Make sure the paper size indicated by yyy is loaded in xxx paper source, then press On Line.

If you do not want to print this job in manual mode, press Continue. The printer feeds paper according to the Paper Source setting.

For detailed information on the Manual Feed mode, see "Printing one sheet at a time" on page 1-11.

---

**Mem Overflow**

---

The printer has insufficient memory available for the current task. To correct the error, press Continue. If the message remains, press Reset.

L

**Flamingo  
Rev. C**

A5 size  
7/16/98

TROUBLE.FM  
Pass 0

Proof Sign-off:

M.Takata

K.Nishi

K.Pipa

\_\_\_\_\_  
\_\_\_\_\_  
\_\_\_\_\_

---

**Form Feed**

---

When the printer is off line and data remains in the printer's memory, press the Form Feed button to print out the data and clear the buffer. After printing, Ready appears on the display.

---

**Image Crtg ID Error**

---

The printer recognizes that the imaging cartridge installed in your printer is not correct. Make sure you are using the proper EPSON imaging cartridge and replace it if needed. See "Replacing the Imaging Cartridge" on page 5-34.

---

**Image Crtg R/W Error**

---

An error occurred with the imaging cartridge. Reinstall it correctly.

If the message still appears, replace it with a new cartridge. See "Replacing the Imaging Cartridge" on page 5-34.

---

**Image Optimum**

---

The printer cannot print at the requested quality level because of insufficient memory, and the printer reduces the quality automatically so that it can continue printing. Check to see if the printout is acceptable. If not, add more memory (for a permanent solution) or temporarily set Device Resolution to Low (300 dpi) and Page Protect to Auto in the driver.

---

**Insert Imaging Crtg**

---

The imaging cartridge is not correctly installed. See "Replacing the Imaging Cartridge" on page 5-34 to reinstall it.

---

If you still cannot close the cover, the imaging cartridge may not be installed correctly. Reinstall the imaging cartridge as described in "Replacing the Imaging Cartridge" on page 5-34.

---

**B Cover Open**

---

Cover B, on the left side of the printer, is open. Pull up the latch on cover B, then close the cover by pushing it into the printer.

---

**Can't Print Duplex**

---

The printer cannot work in double-printing feature. Make sure you are using the correct type and size for the Duplex Unit.

---

**Check Paper Type**

---

The paper type setting in SelecType, or in the printer driver, is different from the type of paper loaded in the printer. Make sure the correct type of paper is loaded in the printer; then press the Continue button to clear the message.

---

**Collate was disabled**

---

The printer does not have sufficient memory to collate print jobs. Only one set of copies will be printed. Reduce the contents of print jobs or add more memory in your printer.

Press the Continue button to clear the message.

---

**C Cover Open**

---

Cover C, on the left side of the optional Large Capacity Paper Unit, is open. Pull the latch on cover C and push it into the unit to close.

L

**Flamingo  
Rev. C**

A5 size  
7/16/98

TROUBLE.FM  
Pass 0

Proof Sign-off:

M.Takata

K.Nishi

K.Pipa

\_\_\_\_\_  
\_\_\_\_\_  
\_\_\_\_\_

---

**Some or all of the output is garbled.**

---

Make sure that both ends of the interface cable are plugged in securely.

Make sure you use a double-shielded, twisted-pair parallel interface cable no longer than six feet in length.

The Image Optimum setting may be set to Auto or On. If it is, certain unexpected fonts may be printed to increase the printing speed. Turn the Image Optimum setting off in the printer driver or SelecType Config Menu.

The emulation setting for that port may not be correct. Specify the correct emulation mode on the SelecType Emulation Menu.

If the printer still does not print correctly, contact your dealer or a qualified service person.

---

**The position of the printout is not correct.**

---

Make sure that you are using the correct page length and margin settings in your application program.

---

**Graphics don't print correctly.**

---

Make sure that your software program is set for the printer emulation you are using. For example, if you are using the LJ4 emulation, be sure that your graphics software is set for a LaserJet 4 printer.

Graphics require large amounts of memory; see "Memory modules" on page 3-47 for more help.

L

**Flamingo  
Rev. C**

A5 size  
7/16/98

TROUBLE.FM  
Pass 0

Proof Sign-off:

M.Takata

K.Nishi

K.Pipa

\_\_\_\_\_  
\_\_\_\_\_  
\_\_\_\_\_

---

## **Option Problems**

---

### **Paper does not feed from the optional Large Capacity Paper Unit.**

Be sure you have selected the proper paper cassette in your software.

There may be no paper in the lower cassette. Load it with paper.

Make sure that the lower cassettes are properly installed as described in "Installing the Large Capacity Paper Unit" on page 3-3.

Make sure you have not tried to load a cassette with too many sheets of paper. The cassettes can hold a maximum of 500 sheets or 1000 sheets (depending on the cassette) of 75g/m<sup>2</sup> (20 lb) paper.

---

### **Even with additional memory installed, complex pages don't print and the Mem Overflow message still appears.**

The Page Protect setting in the printer driver or SelecType may need to be changed.

You may not have enough memory installed. If you are printing at 600 dpi, printing at 300 dpi may solve the problem.

---

## **Other Problems**

---

### **The display panel stays blank when you turn the printer on.**

Turn off the printer and check the power cord connections between the printer and the electrical outlet; then turn the printer back on.



Clean internal printer components by printing several pages with only one character per page.

If the problem remains, replace the imaging cartridge as described in "Replacing the Imaging Cartridge" on page 5-34.

---

### **Missing areas on printed image**

---

Your paper may be moist or damp. Printing is sensitive to moisture absorbed by the paper. The higher the moisture content in the paper, the lighter the printed output. Do not store your paper in a humid or damp environment.

You may not be using the correct type of paper for your printer. If the surface of your paper is too rough, printed characters appear distorted or broken. Smooth, high-quality copier paper is recommended for best results. See "Choosing Paper" on page 1-2 and "Paper Specifications" on page A-2 for information on choosing paper.

---

### **Completely blank pages**

---

If after checking the SelecType Toner option in the Setup Menu, the Toner message indicates that the amount of toner is low (E\*F), read "Replacing the Imaging Cartridge" on page 5-34.

Check that the imaging cartridge is installed as described in "Replacing the Imaging Cartridge" on page 5-34.

The problem may be with your software program or interface cable. Print out a status sheet. If blank pages continue to print, the problem may be with the printer. Turn off the printer and contact your dealer.

2. Open the transparent cover inside.
3. Carefully remove any paper you find jammed in cover DM. If you cannot find any jammed paper, it may be in another area.

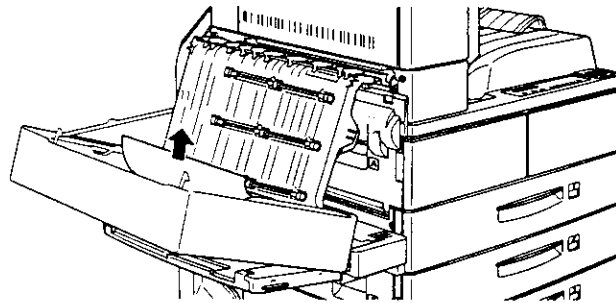

4. Close cover DM. If you removed the Envelope Feeder, reinstall it.
5. When the paper jam is cleared completely, the jammed page's print data is automatically reprinted.

If the control panel indicates another area, check for a paper jam there.

---

## ***Print Quality Problems***

---

### ***Dark or dirty background***

---

Lighten the Density setting using the printer driver or the SelecType Config Menu.

Clean the paper path inside the printer with a clean, soft, and lint-free cloth. See "Cleaning the Printer" on page 5-40.

---

**Jam D (D is part of an option)**

---

This message indicates that paper jam may be occurring inside of cover D, or the optional Multibin Unit.

1. Open cover D on left side of the optional Multibin Unit.
2. Carefully remove any paper you find jammed in cover D or the Multibin Unit.

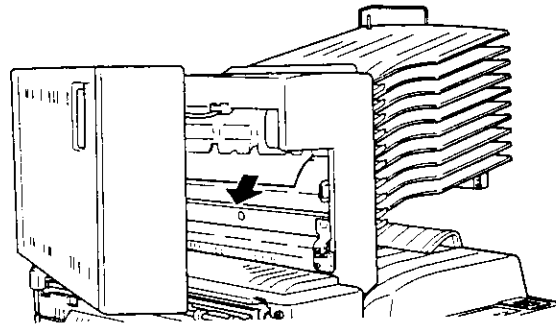
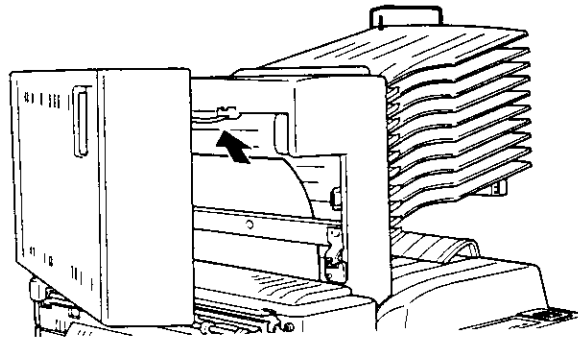

If you do not find any jammed paper, it may be in other area.

3. Close cover D.

4. Clear other paper jams that are indicated on the control panel.
5. After that, if the control panel still indicates LC4 or LC5, completely remove lower cassette 3, and pull out both the lower cassette 4 and 5 as far as they will go.
6. Carefully remove any sheets that have fed part way into the printer.

**Warning:**

*Be careful not to touch any of the sharp parts inside the printer.*

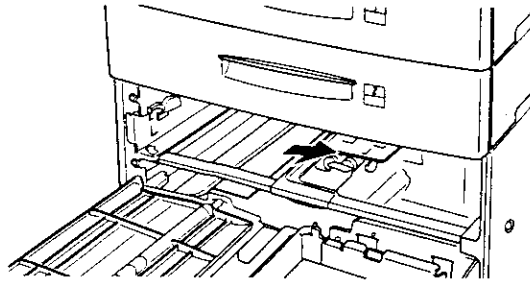

7. Reinstall lower cassette 3 and push all the cassettes back into the unit.

When the paper jam is cleared completely, the jammed page's print data is automatically reprinted.

---

**Jam ENV (ENV is an option)**

---

This message indicates that there may be a paper jam in the optional envelope feeder.

L

**Flamingo  
Rev. C**

A5 size  
7/16/98

TROUBLE.FM  
Pass 0

Proof Sign-off:

M.Takata

K.Nishi

K.Pipa

\_\_\_\_\_  
\_\_\_\_\_  
\_\_\_\_\_

6. When the paper jam is cleared completely, the jammed page's print data is automatically reprinted.

If the control panel indicates another area, check for paper jam there.

---

**Jam B or Jam C (C is part of an option)**

---

This message indicates that there may be a paper jam inside cover B or C.

1. Open the indicated cover (B or C on left side of the printer).
2. Carefully remove any paper you find jammed inside the cover. If you do not find any, paper may be jammed in another area.

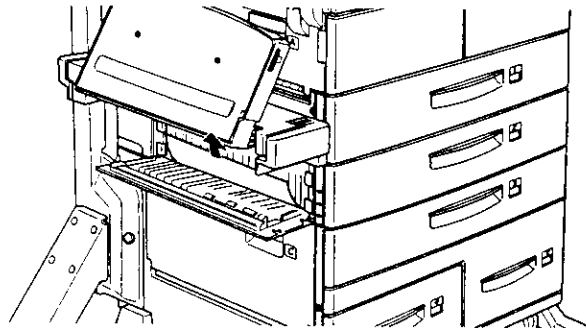

3. Close the cover.
4. When the paper jam is cleared completely, the jammed page's print data is automatically reprinted.

If the control panel indicates another area, clear the paper jam there.

L

**Flamingo  
Rev. C**

A5 size  
7/16/98

TROUBLE.FM  
Pass 0

Proof Sign-off:  
M.Takata  
K.Nishi  
K.Pipa

\_\_\_\_\_  
\_\_\_\_\_  
\_\_\_\_\_

**Note:**

*Because the toner on the paper inside the printer may not have been fixed on the page, toner may come off on your hands when you remove the paper. If you spill toner on your clothing, rinse it off with cold water. Using hot water may leave a permanent stain.*

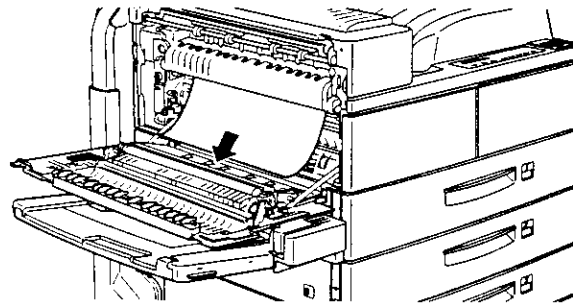
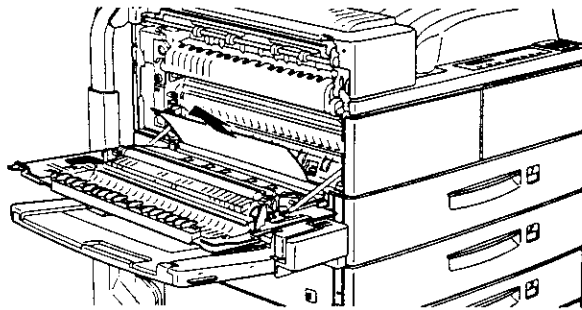

9. The jammed page's print data is automatically reprinted.

---

**Jam MP**

---

This message indicates that there may be a paper jam in the MP (Multi Purpose) Tray.

1. Move the paper guide on the MP Tray outwards.
2. Remove all the paper from the tray, and discard any wrinkled or folded sheets.

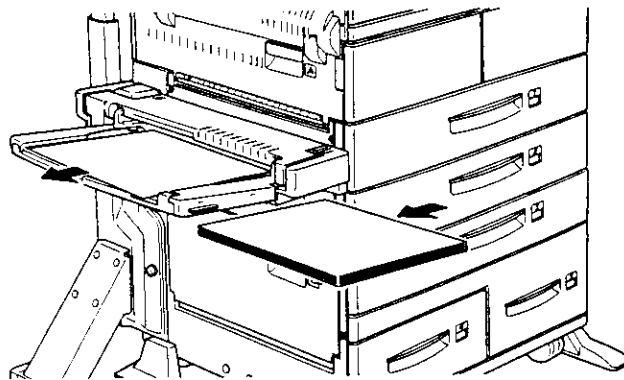

3. Tap the edges of the paper stack on a flat surface. Then reload the paper in the MP Tray, making sure it is evenly aligned and rests below the maximum paper mark.

Make sure you are using the correct paper size and that your paper meets the specifications for this printer.

4. Clear any other paper jams indicated on the control panel.
5. After that, if the control panel still indicates **Jam MP**, completely remove the MP Tray.

---

**Jam LC1, Jam LC2 or Jam LC3 (LC3 is part of an option)**

---

This message indicates that paper jam may be occurring in lower cassette 1, 2, or 3 (LC3 appears if the optional Large Capacity Paper Unit is installed).

1. Pull out the indicated cassette (lower cassette 1, 2, or 3).
2. Carefully remove any paper you find jammed inside the cassette or printer.

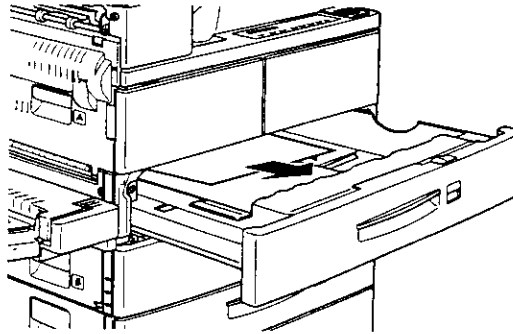

3. Remove the stack of paper from the cassette. Even its edges by tapping the paper on a flat surface. Then reinsert the stack into the cassette making sure the paper is evenly aligned and rests below the maximum paper mark.

Make sure you are using the correct paper size and that your paper meets the specifications for this printer.

4. Reinstall the cassette.
5. Clear other paper jams that are indicated on the control panel.



---

## **Introduction**

This chapter provides information necessary for you to keep the printer in optimum condition. It includes information on:

- Solving problems you may encounter
- Replacing consumables
- Optimizing print quality

Also included is a complete description of the status, error, and warning messages shown on the printer's control panel display.

---

## **Preventing Paper Feed and Paper Jam Problems**

To prevent frequent paper feed or paper jam problems, use this checklist of corrective measures.

- Use a higher-quality paper, one that is not too thin or rough.
- Fan the stack of paper and then tap its edges to align it before you load it.
- Be sure that you do not load too much paper in the paper sources.
- Be sure to adjust the paper guides so that the paper can slide in and out freely.
- Never let the amount of accumulated sheets exceed the total output capacity of any output tray or bin.
- Make sure you load paper with the correct side up. Most packages of paper indicate the top side of the paper with an arrow at the side of the package.

L

**Flamingo  
Rev. C**

A5 size  
7/16/98

SELEC.FM  
Pass 0

Proof Sign-off:  
M.Takata  
K.Nishi  
K.Pipa

\_\_\_\_\_  
\_\_\_\_\_  
\_\_\_\_\_

*Character Set*

Selects character table 1 or 2.

### *Auto CR*

This selects whether the printer performs a carriage-return/line-feed (CR-LF) operation whenever the printer position goes beyond the right margin. If this setting is off, the printer does not print any characters beyond the right margin and does not perform any line wrapping until it receives a carriage-return character. This function is handled automatically by most software applications.

### *Auto LF*

If you set this option to Off, the printer does not send an automatic line-feed (LF) command with each carriage-return (CR). If this is set to On, a line-feed command is sent with each carriage-return. Set to On if your text lines overlap.

### *Bit Image*

If you set this parameter to Dark or Light, the printer is able to emulate the graphics densities set with the printer commands. If you select Dark, the bit image density is high, and if you select Light, the bit image density is low.

If you select the BarCode setting, the printer converts bit images to bar codes by automatically filling in any vertical gaps between dots. This produces unbroken vertical lines that can be read by a bar code reader. This mode will reduce the size of the image being printed, and may also cause some distortion when printing bit image graphics.

### *ZeroChar*

Selects whether the printer prints a slashed or unslashed zero. This is useful for distinguishing between an uppercase O and a numeric 0 when printing program listings, for example.

L

**Flamingo  
Rev. C**A5 size  
7/16/98SELEC.FM  
Pass 0Proof Sign-off:  
M.Takata  
K.Nishi  
K.Pipa\_\_\_\_\_  
\_\_\_\_\_  
\_\_\_\_\_**ESCP2 and FX menus**

This menu allows you to make settings which affect the printer when it is in ESCP2 or FX emulation mode. The same menu items are available for both emulation modes unless specifically mentioned otherwise.

Item	Values
Font	<b>Courier</b> , Prestige, Roman, Sans Serif, Roman T, Orator S, Sans H, Script, OCR A, OCR Be
Pitch	10, 12, 15 (cpi), Prop.
Condensed	<b>Off</b> , On
T. Margin	0.40 ... <b>0.50</b> ... 1.50 inch in 0.05 increments
Text	1... <b>62/66</b> * ... 111 lines
CGTable	<b>PcUSA</b> , Italic, PcMultilin, PcPortugue, PcCanFrenc, PcNordic, PcTurkish2, PcE.Europe, BpBRASCI, BpAbicomp
Country	<b>USA</b> , France, Germany, UK, Denmark, Sweden, Italy, Spain1, Japan, Norway, Denmark2, Spain2, LatinAmeric, Korea, Legal
Auto CR	<b>On</b> , Off
Auto LF	<b>Off</b> , On
Bit Image	<b>Dark</b> , Light, BarCode
ZeroChar	<b>0</b> .

\* Depending on whether Letter (62) or A4 (66) paper has been selected

**Font**

Selects the font which is used for printing.

Item	Values
Scale	Off, A0, A1, A2, A3
Origin	Corner, Center
Pen	Pen0, Pen1, Pen2, Pen3, Pen4, Pen5, Pen6
End	Butt, Square, Triangular, Round
Join	Mitered, Miteredbeveled, Triangular, Round, Beveled, None
Pen 0 through 6	0.05 ... 0.35 ... 5.00 mm in 0.05 increments

### *GL-Mode*

Specifies whether the emulation is similar to the GL/2 or the HP LaserJet 4 emulation of the GL/2.

### *Scale*

Specifies whether the output from the software is scaled, and if so, how the scale factor is calculated: based on the output paper size of the software application.

### *Origin*

Specifies whether the logical origin of the "plotter" is from the corner or the center of the paper.

### *Pen*

Allows you to choose a pen which you can then set the thickness for in the Pen 0 through 6 menu item. The LJ4GL2 mode supports two pens (0 and 1), while the GLlike mode supports seven pens (0 through 6).

### *End*

Specifies the way in which lines end.

## LJ4 Menu

Item	Values
Font Source	<b>Resident</b> , Download, ROM A, ROM B
Font Number	0 to 65535 (depending on your settings)
Pitch	0.44 ... <b>10.00</b> ... 99.99 cpi in 0.01 increments
Height	4.00 ... <b>12.00</b> ... 999.75 pt in 0.25 increments
SymSet	<b>IBM-US</b> , Roman-8, ECM94-1, 8859-2 ISO, 8859-9 ISO, IBM-DN, PcMultiling, PcE.Europe, PcTk437, WtAnsi, WtE.Europe, WtTurkish, DeskTop, PsText, VeInternati, VeUS, MsPublishin, Math-8, PsMath, VeMath, PiFont, Legal, UK, ANSI ASCII, Swedis2, Italian, Spanish, German, Norweg1, French2, Windows
Form	5 ... <b>64</b> ... 128 lines
Source SymSet	0 ... <b>277</b> ... 3199
Dest SymSet	0 ... <b>277</b> ... 3199

### Note:

*If you always use the HP LaserJet 4 printer driver in your software, you should change settings using your software. The software settings always override the LJ4 menu options.*

### FontSource

Specifies the default font source.

### Font Number

Specifies the default font number for the default font source.

### Pitch

Specifies the default font pitch if the font is scalable and fixed-pitch. You can select from 0.44 to 99.99 CPI, in increments of 0.01 CPI.

**Bi-D**

Enables or disables bidirectional communication.

**Buffer Size**

Determines the amount of memory to be used for receiving data and printing data. If set to Maximum, more memory is allocated for receiving data. If set to Minimum, more memory is allocated for printing data. The default setting is Normal.

**Note:**

- After changing this setting, reboot the printer to make the new setting effective. To reboot the printer, press the Continue and SelectType buttons simultaneously. Alternatively, turn off the printer, then after 5 seconds, turn it back on.
- Rebooting the printer erases all print jobs. Make sure the On Line light is not blinking when you reboot the printer.

**Network Menu**

These items are for making network settings. Have your network administrator make these settings while referring to the *Administrator's Guide*.

Item	Values
Get IPAddress	Panel, DHCP, PING
IP Byte 1	0 to 255
IP Byte 2	0 to 255
IP Byte 3	0 to 255
IP Byte 4	0 to 255
SM Byte 1	0 to 255
SM Byte 2	0 to 255
SM Byte 3	0 to 255

*Time Out*

Sets the length of time the printer waits when it is on line and no new data is received. When this time is up, the printer searches for new print data on other channels.

*Standby*

Saves power by reducing the power to the fixing heater if the printer receives no data for 60 minutes. In this mode, the printer begins warming up as soon as you send a print job; it then warms up and is ready to print in about 60 seconds at rated voltage.

*Lang*

Specifies the language displayed on the control panel and printed on the status sheet.

*Toner*

Displays the amount of toner left in the imaging cartridge.

E****F	(100-75%)
E*** F	(75-50%)
E** F	(50-25%)
E* F	(25-0%)
E F	(0%)

*Face-up Enable*

Turn this setting on after installing the optional face-up tray. If you do not select ON, you cannot use the optional face-up tray even though it is physically installed in the printer.

*Note:*

- After changing this setting, reboot the printer to make the new setting effective. To reboot the printer, press the Continue and SelectType buttons simultaneously. Alternatively, turn off the printer, then after 5 seconds, turn it back on.
- Rebooting the printer erases all print jobs. Make sure the On Line light is not blinking when you reboot the printer.



L

**Flamingo  
Rev. C**

A5 size  
7/16/98

SELEC.FM  
Pass 0

Proof Sign-off:

M.Takata

K.Nishi

K.Pipa

\_\_\_\_\_  
\_\_\_\_\_  
\_\_\_\_\_

*Top Offset B*

Adjusts the vertical printing position on the back side when printing on both sides. Use this if the printout on the back side is not where you expected. This item is available only when the Duplex Unit is installed.

*Left Offset B*

Adjusts the horizontal printing position on the back side when printing on both sides. Use this if the printout on the back side is not where you expected. This item is available only when the Duplex Unit is installed.

*Size Ignore*

Selects whether a paper size error is ignored. Turning this item on causes the printer to print even if the image size exceeds the printable area for the specified size of paper. This may cause smudges because of toner that is not transferred onto the paper properly. When this item is off, the printer stops printing if a paper size error occurs.

*Auto Cont*

Permits the printer to automatically continue printing after a certain period of time when one of the following errors occurs: Paper Set, Print Overrun or Mem Overflow. When this option is off, you must press the Continue button to resume printing.

*Page Protect*

Allocates additional printer memory for printing data, as opposed to receiving it. You may need to use Page Protect if you are printing a very complex page. If a Print Overrun error occurs, change the setting to ON and reprint your data. This reduces the amount of memory reserved for receiving data so your computer may take longer to send the print job, but it will allow you to print complex jobs. Page Protect usually works best if set to Auto. You will need to increase your printer's memory if memory errors continue to occur.

*LC1 Type, LC2 Type, LC3 (option) Type, LC4 (option) Type, LC5 (option) Type*

Displays the paper type you are selecting for the standard or optional lower paper cassette.

**Config Menu**

Item	Values
RItech	On, Off
Toner Save	Off, On
Density	1, 2, 3, 4, 5
Top Offset	-150.0 ... 0.0 ... 150.0 mm in 0.5 increments
Left Offset	-150.0 ... 0.0 ... 150.0 mm in 0.5 increments
Top Offset B*	-150.0 ... 0.0 ... 150.0 mm in 0.5 increments
Left Offset B*	-150.0 ... 0.0 ... 150.0 mm in 0.5 increments
Size Ignore	Off, On
Auto Cont	Off, On
Page Protect	Auto, On
Image Optimum	Auto, Off, On

\* These appear only when the corresponding option is installed.

**RItech**

Produces smoother and crisper lines, text, and graphics.

**Note:**

You can also make the RItech setting directly from OneTouch Mode 2.

### *Manual Feed*

Allows you to select manual feed mode for all paper sources. For details on manual feed mode, see "Printing one sheet at a time" on page 1-11.

**Note:**

You can also make this setting directly from *OneTouch Mode 1*.

### *Resolution*

Switches the resolution between 300 and 600 dpi.

### *Skip Blank Page*

Enables you not to print the blank pages. This setting is not available when you print in GL2, ESCP2, FX, or I239X mode.

### *Duplex*

Turns duplex printing on or off. This item is available only when the Duplex Unit is installed.

### *Binding*

Specifies the binding direction of the printout. This item is available only when the Duplex Unit is installed.

### *Start Page*

Specifies whether printing starts from the front or back side of the page. This item is available only when the Duplex Unit is installed.

### *Offset Stacking*

Lets you separate each set of printed copies when printing to the face-down tray. When this setting is on, the first and second set of printed copies or print jobs are ejected to slightly different locations on the face-down tray. This process is repeated, resulting in each set of printed copies or print jobs being offset from the next set.

## Printing Menu

The settings in the Printing menu can be made from within your software. The settings you make in your software override SelecType settings.

Some items in the Printing menu can be accessed directly through the OneTouch Modes. See "Using the OneTouch Modes" on page 2-7.

Item	Values
Paper Source	Auto, MP, ENV*, LC1, LC2, LC3*, LC4*, LC5*
Page Size	A4, A3, A5, B4, B5, LT, HLT, LGL, GLT, GLG, B, EXE, F4, MON, C10, DL, C5, IB5, CTM
Wide A4	Off, On
Orientation	Port, Land
Out Bin	Face-down, Face-up*, Mailbox1*, Mailbox2*, to Mailbox10*, Stacker*
Copies	1 to 999
Manual Feed	Off, On
Resolution	600, 300
Skip Blank Page	Off, On
Duplex*	Off, On
Binding*	Long Edge, Short Edge
Start Page*	Front, Back
Offset Stacking	Off, On

\* These appear only when the corresponding option is installed.

### Paper Source

Specifies whether paper feeds into the printer from the MP Tray, the optional envelope feeder, the standard lower paper cassette, or from an optional lower paper cassette.

### *GL2 Menu*

These settings are available only when the printer is in GL2 mode.

### *PS3 Menu*

These settings are available only when the optional Adobe PostScript 3 Kit is installed. For more information, refer to the Adobe PostScript 3 documentation.

### *ESCP2 Menu*

These settings are available only when the printer is in ESC/P 2 mode.

### *FX Menu*

These settings are available only when the printer is in FX mode.

### *I239X Menu*

These settings are available only when the printer is in I239X mode.

---

## **SelectType Settings**

Read this section for a complete description of the settings available on the SelectType menus. In the following tables, **bold** type indicates standard factory settings.

### **Test Menu**

Press Item to select a sheet or font sample, then press Enter to print. There are no settings to select by pressing Value.



**Caution:**

*After you print these samples, user-defined data stored in the printer, such as download fonts, may be erased depending on which sample you printed.*

Menu	Items
Config Menu	RItech, Toner Save, Density, Top Offset, Left Offset, Top Offset B*, Left Offset B*, Size Ignore, Auto Cont, Page Protect, Image Optimum
Setup Menu	Interface, Time Out, Standby, Lang, Toner, Face-up Enable, Multibin*, Page Count, SelecType Init
Parallel Menu	Speed, Bi-D, Buffer Size
Network Menu	Get IPAddress, IP Byte1, IP Byte2, IP Byte3, IP Byte4, SM Byte1, SM Byte2, SM Byte3, SM Byte4, GW Byte1, GW Byte2, GW Byte3, GW Byte4, Buffer Size
AUX Menu*	Buffer Size
LJ4 Menu	Font Source, Font Number, Pitch, Height, SymSet, Form, Source SymSet*, Dest SymSet*
GL2 Menu	GLMode, Scale, Origin, Pen, End, Join, Pen0, Pen1, Pen2 to Pen6
PS3 Menu*	Error Sheet
ESCP2 Menu	Font, Pitch, Condensed, T.Margin, Text, CG Table, Country, Auto CR, Auto LF, Bit Image, ZeroChar
FX Menu	Font, Pitch, Condensed, T.Margin, Text, CG Table, Country, Auto CR, Auto LF, Bit Image, ZeroChar
I239X Menu	Font, Pitch, Code Page, T.Margin, Text, Auto CR, Auto LF, Alt. Graphics, Bit Image, ZeroChar, CharacterSet

\* These Items appear only when the corresponding option is installed.

### Test Menu

From this menu you can perform an internal test printing which includes information on the printer's current settings and available fonts.

### Emulation Menu

This menu allows you to set the default emulation mode for each interface.

## When to Use SelecType

In general, use SelecType only for settings you cannot make in your software, including the following:

- Changing the emulation modes and selecting the IES (Intelligent Emulation Switching) mode
- Specifying a channel and configuring the interface
- Choosing the size of the memory buffer used to receive data

Keep in mind the following when using SelecType settings:

- A number of SelecType settings can also be made using the OneTouch modes and printer driver.
- Application programs may send commands to the printer that override SelecType settings. If you are not getting the results you expect, check your application software settings.
- To see the current SelecType settings, print a status sheet.
- A map of all available SelecType menus is included in Appendix E.

## Using SelecType

**Note:**

You can directly access certain menu items using the OneTouch modes. For more information, see "Using the OneTouch Modes" on page 2-7.

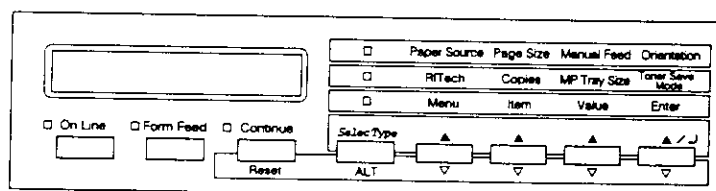

L

**Flamingo  
Rev. C**

A5 size  
7/16/98

OPTIONS.FM  
Pass 0

Proof Sign-off:

M.Takata

K.Nishi

K.Pipa



***Using it as a sorter***

You can use this multibin unit as a sorter, like those on copiers.

***Using it as a large capacity stacker***

The Multibin Unit can function as an additional output tray, in combination with the standard face-down tray. This combination allows you to print 1500 sheets in total.

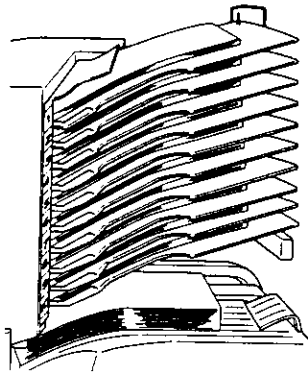

***Note:***

*The offset stacking mode is not available with the Multibin Unit.*





## Envelope feeder

The envelope feeder enables you to print on the following envelopes.

Monarch, Commercial 10, DL, C5

**Caution:**

*Always use the optional envelope feeder when you print on the envelopes listed above; otherwise, the printer will not work properly and can be damaged.*

**Note:**

*You can print on International B5 envelopes with the MP Tray.*

1. Always load envelopes in the envelope feeder with their flaps folded and facing up, as shown below.

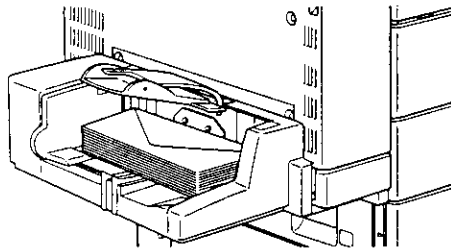

2. Adjust the paper guide to match the paper size and lower the bar onto the envelopes to feed them correctly.

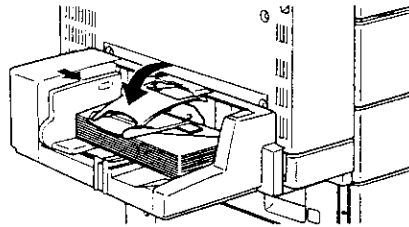

### **Duplex Unit**

The Duplex Unit enables you to print on both sides of plain paper and supports the following paper sizes.

A3, A4, A5, Ledger, Letter, HLT, Legal, GLG, Executive.

To use the Duplex Unit, select the duplex function in your printer driver or in SelecType.



**Caution:**

*You cannot print on labels, envelopes, or transparencies with the Duplex Unit.*

### **Face-up tray**

The face-up tray holds up to 200 sheets with the printed side up. Use this option to view the printouts during printing.

To use the face-up tray, set Face-up Enable to On in SelecType.



**Caution:**

*You cannot print on envelopes, labels or transparencies using the face-up tray.*

**Note:**

*To eject printouts on the face-up tray in decreasing order from the bottom, select the function in your software that enables you to print from the last page, if available.*



2. Remove the two screws that secure the Type-B slot cover and remove the cover.

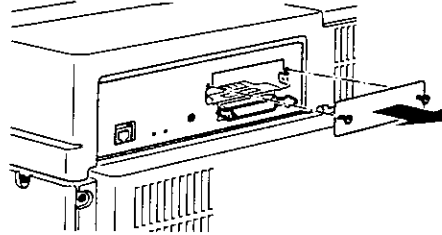

3. With the component side of the optional interface card facing up, slide the interface card into the grooves of the interface slot as shown below. Push the card firmly to lock it into place.

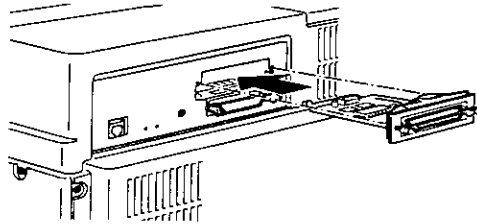

4. Secure the interface card with the two retaining screws.

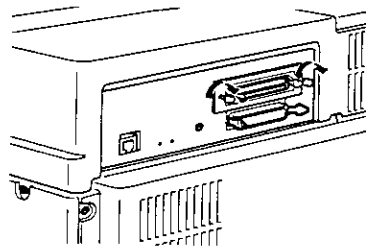

To confirm that the interface card is installed correctly, print a status sheet.

2. Locate the button on the side of the SLOT housing for the ROM module you want to remove. Push down the button until the module comes up.

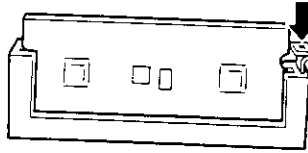

3. Pull the ROM module up and out of the slot.
4. Follow steps 1 through 4 in "After installing" on page 3-51 to complete the procedure.

### **Optional interfaces**

This section describes how to install the optional interface cards listed below.

- To add a direct connection to an Ethernet system, use an optional Ethernet Card (C82362\*/C82363\*).
- To add a serial or parallel interface to your printer, use one of the following:
  - 32KB Serial Interface Card C82307\*
  - 32KB Parallel Interface Card C82310\*
- To add a direct connection to an IBM mini or mainframe system, use one of the following:
  - Coax Interface Card C82314\*
  - Twinax Interface Card C82315\*

2. Pull the clips on each side of SLOT S1 or S2 outward to release the memory module.

**Note:**

*SLOT S0 should always have a memory module installed.*

3. Grasp both sides of the memory module and pull the module out.

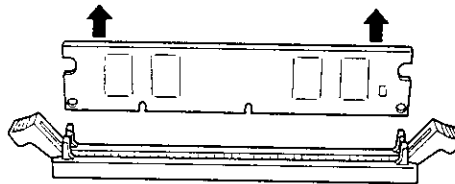

4. Follow steps 1 through 4 in "After installing" on page 3-51 to complete the procedure.

**ROM module**

Follow the instructions below to install the Adobe PostScript 3 ROM module (C83232\*).

**Installing the ROM module**

1. Follow steps 1 through 6 in "Before installing" on page 3-47.

L

**Flamingo  
Rev. C**

A5 size  
7/16/98

OPTIONS.FM  
Pass 0

Proof Sign-off:  
M.Takata  
K.Nishi  
K.Pipa

\_\_\_\_\_  
\_\_\_\_\_  
\_\_\_\_\_

3. Hold the memory module above SLOT S1 with the following orientation, then push it down into SLOT S1. Do not apply too much force.

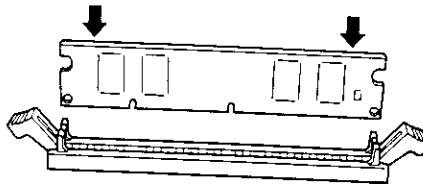

4. At the right side, push the bottom corner of the memory module until the clip comes up.

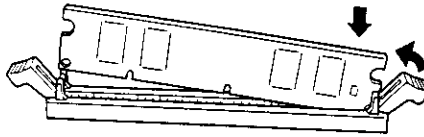

5. With the other hand, push the bottom corner of the memory module until the clip comes up to retain the memory module securely.

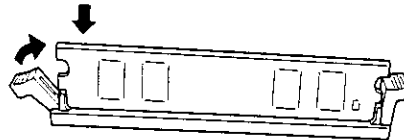

6. To install another memory module in SLOT S2, repeat steps 2 through 5.



3. Remove all interface cables from the interface connectors.
4. Remove the Multibin Unit if it is installed. See "Removing the Multibin Unit" on page 3-41.
5. Open the top cover of the face-down tray with your fingers.

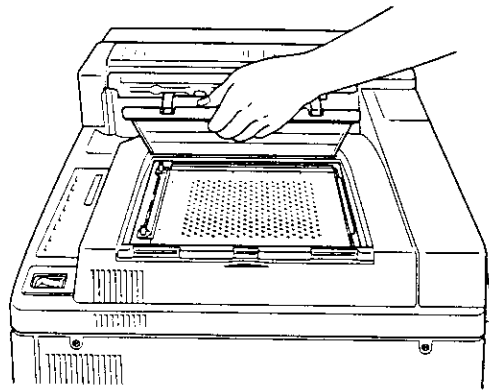

6. Loosen the two retaining screws and remove the plate.

**Note:**

*To avoid losing the retaining screws, do not remove them completely from the plate.*

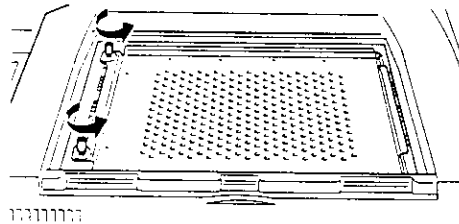

**Caution:**

*If you place the Multibin Unit temporary on a desk or floor, always keep the bins pointing up; doing otherwise can damage the unit.*

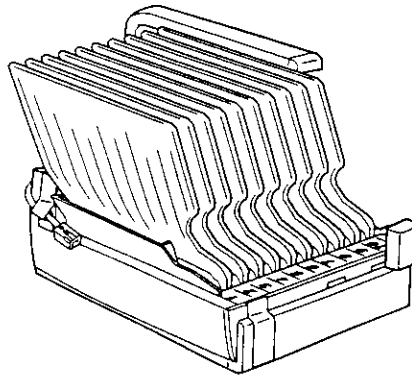

4. Push the locks and lift up the top bracket.

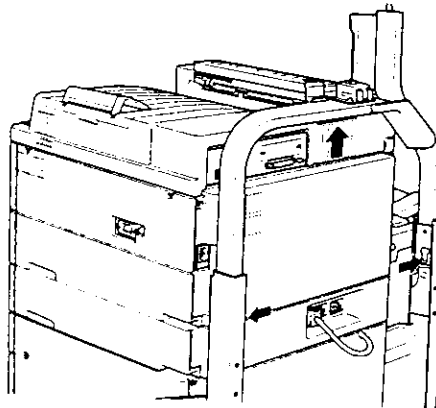

*After removing*

1. Reconnect any interface cables you removed.



3. Open cover D and attach the grip to the inside of the unit. To do so, position the grip as shown below, push it in and lift it up slightly until it clicks.

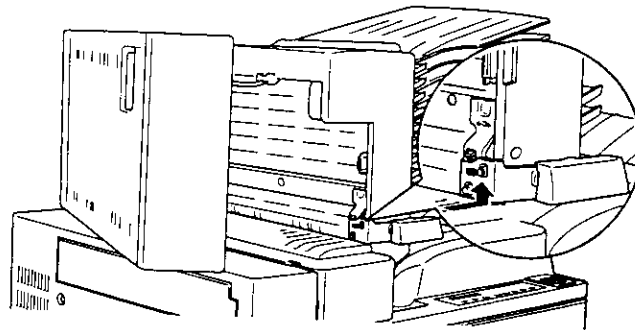

### Removing the Multibin Unit

1. Grasp the Multibin Unit at the shaded areas below.

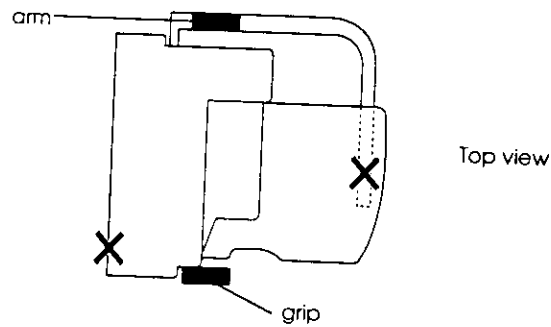

**Caution:**

Do not support the unit at the areas above marked with X (the latch on cover D and the end of the arm). Doing so can damage the cover or the unit.



3. Remove all interface cables from the interface connectors.
4. Unplug the cord of the Multibin Unit from its connector on the back of the printer.

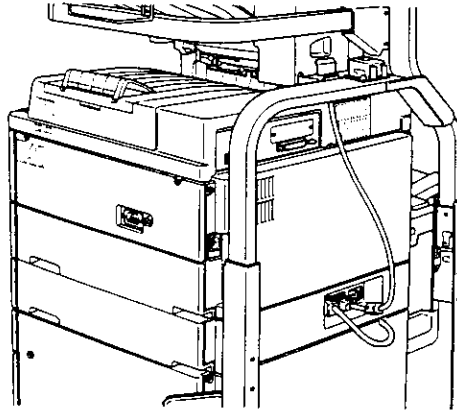

5. Detach the sheet stopper by pulling its ends out of the top and bottom bins.

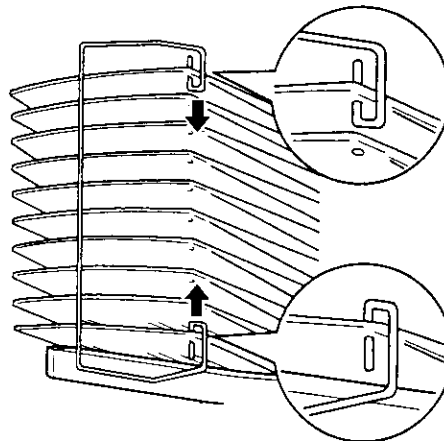

*After installing*

1. Open cover D and remove all protective materials inside and outside the Multibin Unit.

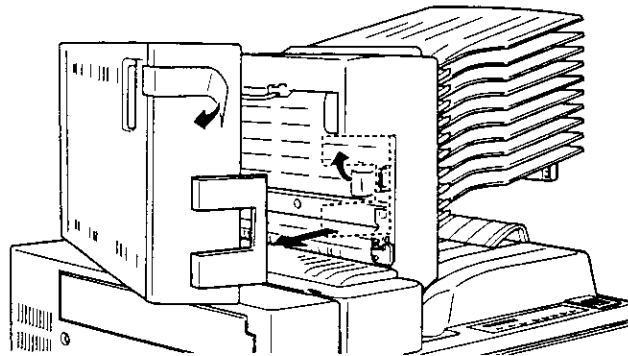

2. Attach the sheet stopper by inserting its two ends into the holes on the top and bottom bin.

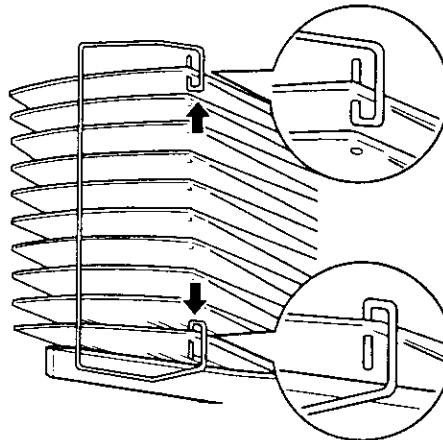



7. Lower the Multibin Unit until the pin fits completely into the hole on the plate.

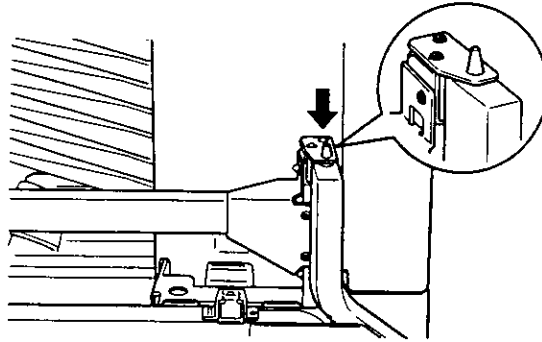

8. Make sure the bottom corner on the opposite side of the unit is set above and parallel with the printer.

#### *Locking the Multibin Unit*

1. Remove the protective tape as shown below.

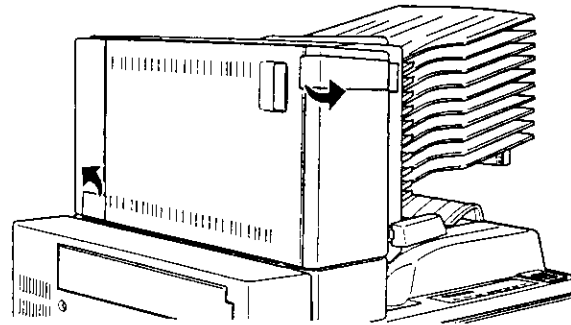

3. Grasp the Multibin Unit at the shaded areas shown below.

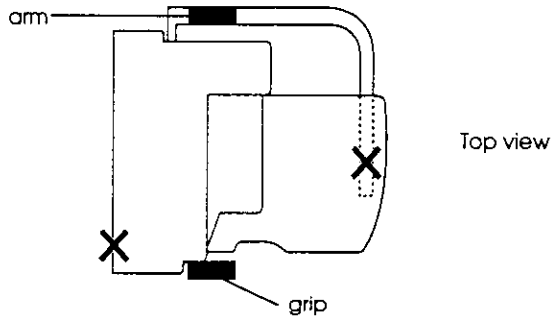

**Caution:**

*Do not support the unit at the areas marked with X above (the latch on cover D and the end of the arm). Attempting so can damage the cover or the unit.*

4. Lift the unit and align the pole on the Multibin Unit with the pole of the top bracket as shown below.

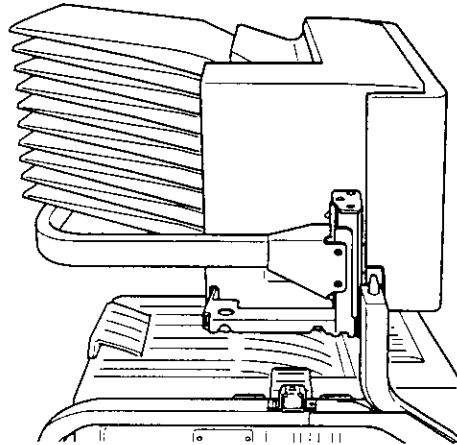

L

**Flamingo  
Rev. C**

A5 size  
7/16/98

OPTIONS.FM  
Pass 0

Proof Sign-off:  
M.Takata  
K.Nishi  
K.Pipa



2. With the orientation shown below, insert the two legs of the top bracket into the side brackets and push down evenly on both sides until the bracket clicks into place.

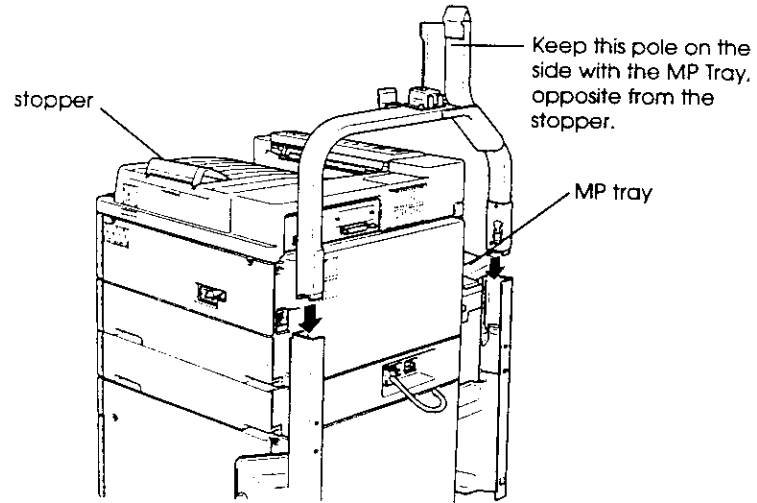

3. Remove the protective material from the top pin.

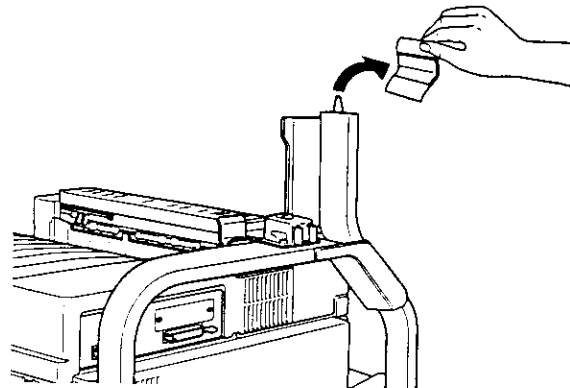



## **Multibin Unit**

This unit can be used as a mailbox, a sorter, or a large capacity stacker. To install, follow the instructions below.

### **Installing the Multibin Unit**

#### *Before installing*

1. Turn off the printer.
2. Unplug the printer's power cord from the electrical outlet.
3. Remove all interface cables from the interface connectors.
4. Open the box from the top. Without removing the Multibin Unit, take out all other parts and protective materials from the box.

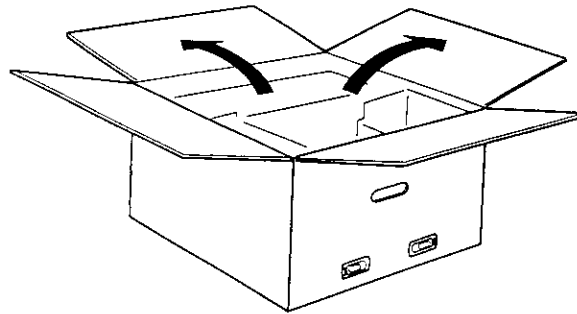

#### *Installing the side brackets*

1. Open the box inside and take out the bracket for the right side shown below.

L

**Flamingo  
Rev. C**

A5 size  
7/16/98

OPTIONS.FM  
Pass 0

Proof Sign-off:  
M.Takata  
K.Nishi  
K.Pipa

\_\_\_\_\_  
\_\_\_\_\_  
\_\_\_\_\_

*After installing*

1. Reconnect any interface cables you removed.
2. Make sure the printer is turned off. Plug the power cord into an electrical outlet.
3. Turn on the printer.

To confirm that the envelope feeder is installed correctly, print a status sheet. If the feeder is not listed on the status sheet, try reinstalling it.

**Removing the envelope feeder**

*Note:*

- When replacing the imaging cartridge or clearing a paper jam, make sure to temporarily remove the envelope feeder before opening cover A.
- Always have either the envelope feeder or the MP Tray installed. If neither of them are installed, the message Set MP Tray appears on the control panel.

To remove the envelope feeder, follow the instructions below.

*Before removing*

1. Turn off the printer.
2. Unplug the printer's power cord from the electrical outlet.
3. Remove all interface cables from the interface connectors.



3. Loosen and remove the two screws to detach the cover.

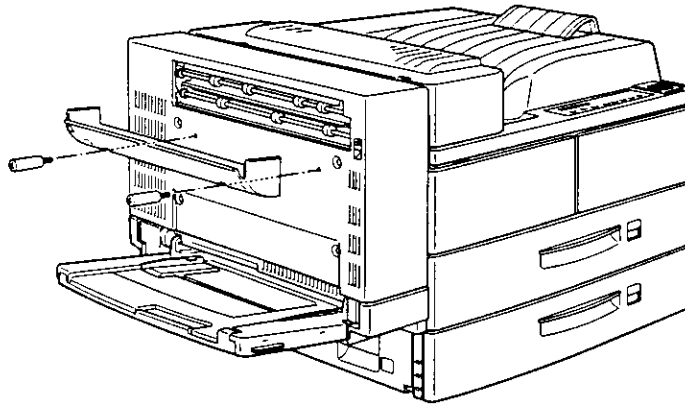

#### *After removing*

1. Reconnect any interface cables you removed.
2. Make sure the printer is turned off. Plug the power cord into an electrical outlet.
3. Turn on the printer.

Make sure to save all parts for future use.

#### **Envelope feeder**

To install the envelope feeder, you must remove the MP Tray first.

#### **Installing the envelope feeder**

Follow the instructions below.

#### *Before installing*

1. Turn off the printer.
2. Unplug the printer's power cord from the electrical outlet.

3. Remove the metal bar from the printer.

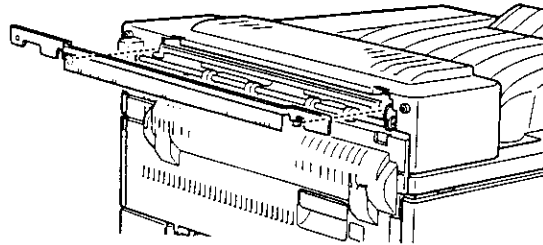

*After removing*

1. Reconnect any interface cables you removed.
2. Make sure the printer is off. Plug the power cord into an electrical outlet.
3. Turn on the printer.

Make sure to save all parts for future use.

***Removing the face-up tray (with the Duplex Unit installed)***

To remove the face-up tray completely from the printer, follow the instructions below.

*Before removing*

1. Turn off the printer.
2. Unplug the printer's power cord from the electrical outlet.
3. Remove all interface cables from the interface connectors.

L

**Flamingo  
Rev. C**

A5 size  
7/16/98

OPTIONS.FM  
Pass 0

Proof Sign-off:

M.Takata

K.Nishi

K.Pipa

\_\_\_\_\_  
\_\_\_\_\_  
\_\_\_\_\_

To confirm that the face-up tray is installed correctly, print a status sheet. If the tray is not listed on the status sheet, try reinstalling it.

**Note:**

*You can open the DM cover without detaching the face-up tray. The tray remains angled to hold printed sheets.*

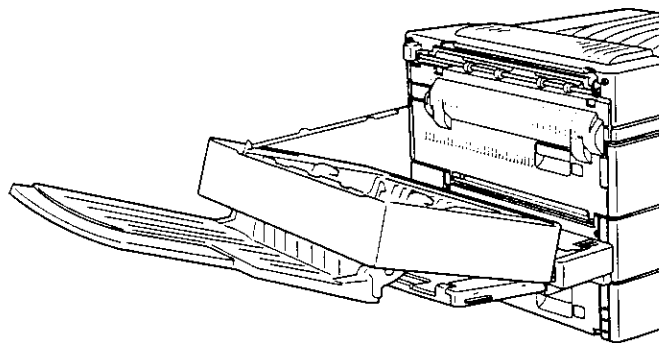

**Removing the face-up tray (without the Duplex Unit installed)**

To remove the face-up tray completely from the printer, follow the instructions below.

*Before removing*

1. Turn off the printer.
2. Unplug the printer's power cord from the electrical outlet.
3. Remove all interface cables from the interface connectors.

L

**Flamingo  
Rev. C**

A5 size  
7/16/98

OPTIONS.FM  
Pass 0

Proof Sign-off:  
M.Takata  
K.Nishi  
K.Pipa



2. Attach the cover to the printer using the two finger screws included with the face-up tray.

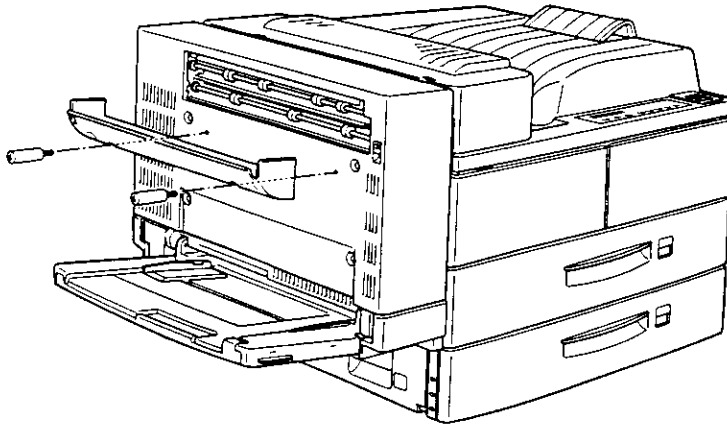

3. Holding the hook as shown below, attach it to the printer by sliding it into the slot.

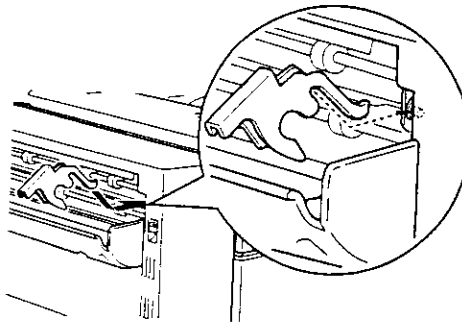

3. Turn on the printer.
4. On the control panel's Setup Menu, set Face-up Enable to On. See "Using SelecType" on page 4-2.

To confirm that the face-up tray is installed correctly, print a status sheet. If the tray is not listed on the status sheet, try reinstalling it.

**Note:**

When replacing the imaging cartridge or clearing a paper jam, make sure to temporarily remove the face-up tray before opening cover A.

To temporarily remove the face-up tray, tilt it upward and lift up.

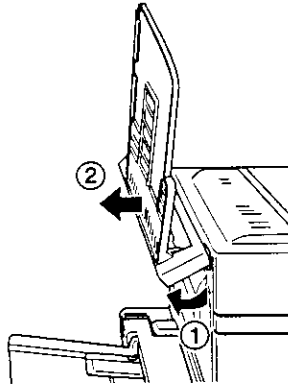

**Installing the face-up tray (with the Duplex Unit installed)**

Follow the instructions below if you will install both the face-up tray and the optional Duplex Unit.

*Before installing*

1. Turn off the printer.
2. Unplug the printer's power cord from the electrical outlet.
3. Remove all interface cables from the interface connectors.

L

**Flamingo  
Rev. C**

A5 size  
7/16/98

OPTIONS.FM  
Pass 0

Proof Sign-off:  
M.Takata  
K.Nishi  
K.Pipa

\_\_\_\_\_  
\_\_\_\_\_  
\_\_\_\_\_

2. Insert and tighten the two finger screws included with the face-up tray as shown below.

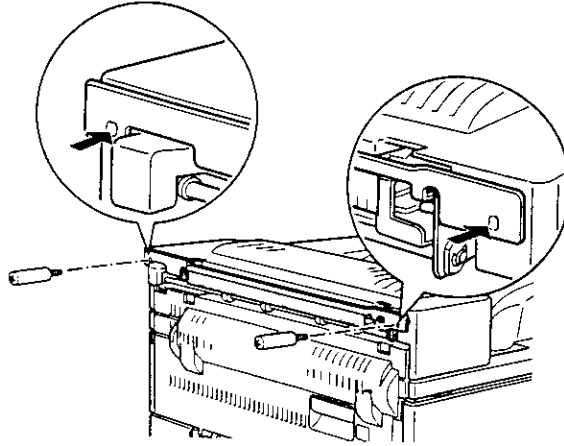

3. Attach the frame to the tray with the two remaining screws.

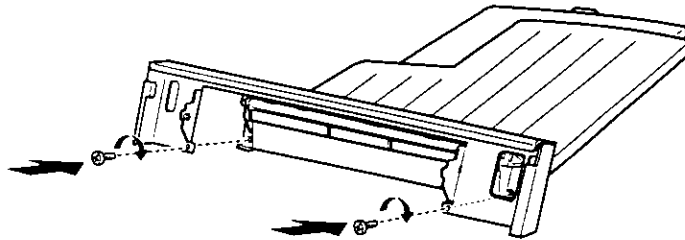

6. Lift up the Duplex Unit with both hands.

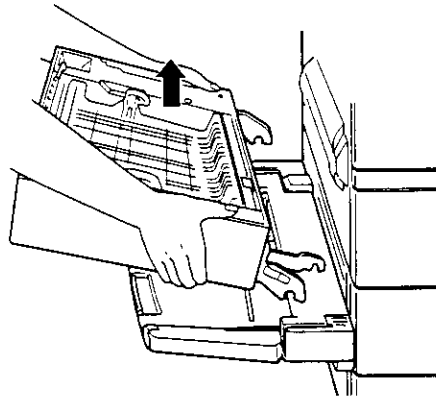

*After removing*

1. Reconnect any interface cables you removed.
2. Make sure the printer is turned off. Plug the power cord into an electrical outlet.
3. Turn on the printer.

**Face-up tray**

Installation and removal procedures differ depending on whether the optional Duplex Unit is installed.

**Installing the face-up tray (without the Duplex Unit installed)**

Follow the instructions below if you will not install the optional Duplex Unit on your printer.

*Before installing*

1. Turn off the printer.
2. Unplug the printer's power cord from the electrical outlet.

3. Remove all interface cables from the interface connectors.

### *Removing*

1. Unplug the cord of Duplex Unit from its connector.

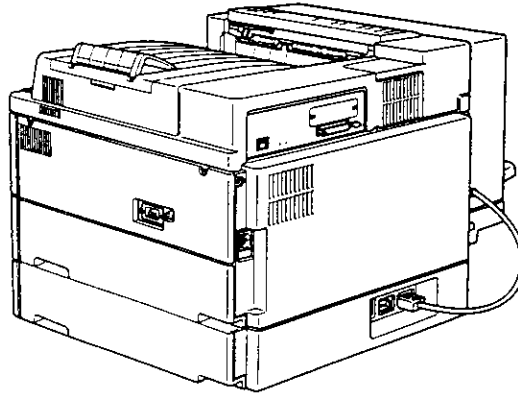

2. Open the DM cover of the unit by pulling up its lever.

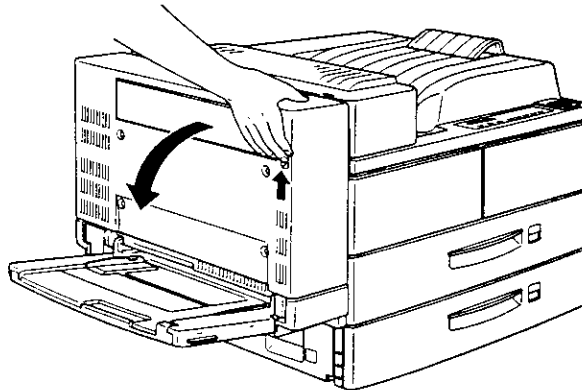

3. Lift up the cover slightly.



L

**Flamingo**  
**Rev. C**

A5 size  
7/16/98

OPTIONS.FM  
Pass 0

Proof Sign-off:  
M.Takata  
K.Nishi  
K.Pipa

\_\_\_\_\_  
\_\_\_\_\_  
\_\_\_\_\_

4. Grasp the strap on the left side of the unit and insert the hook at the end of the strap into the printer's slot as shown below.

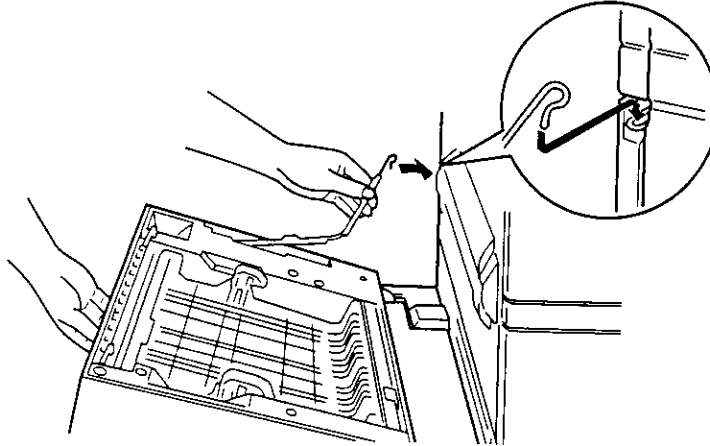

5. Close the Duplex Unit until it clicks.

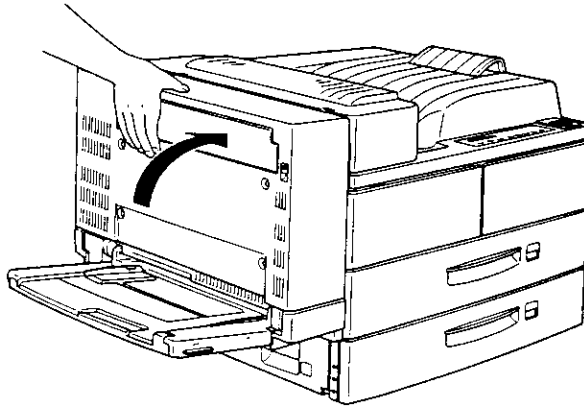

To confirm that the Large Capacity Paper Unit is installed correctly, print a status sheet. If a cassette is not listed on the status sheet, try reinstalling it.

### **Duplex Unit**

This unit allows you to print on both sides of paper automatically. To install the unit, follow the instructions below.

### **Installing the Duplex Unit**

#### *Before installing*

1. Turn off the printer.
2. Unplug the printer's power cord from the electrical outlet.
3. Remove all interface cables from the interface connectors.
4. Unpack the Duplex Unit and remove all protective materials.



**Caution:**

*Open the inner tray and remove the protective insert; otherwise, the printer will not work properly.*

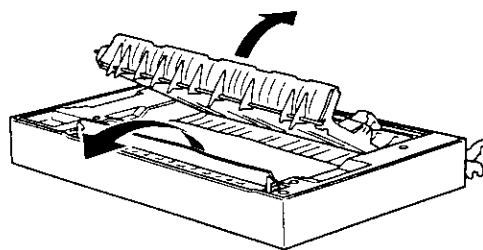

#### *Installing*

1. Lift the Duplex Unit with both hands, and face the left side of the printer.

3. From lower cassette 3, take out and open the included package of metal fittings and screws.
4. Attach the two metal fittings with the screws as shown below. Note that the shapes of the two fittings are different.

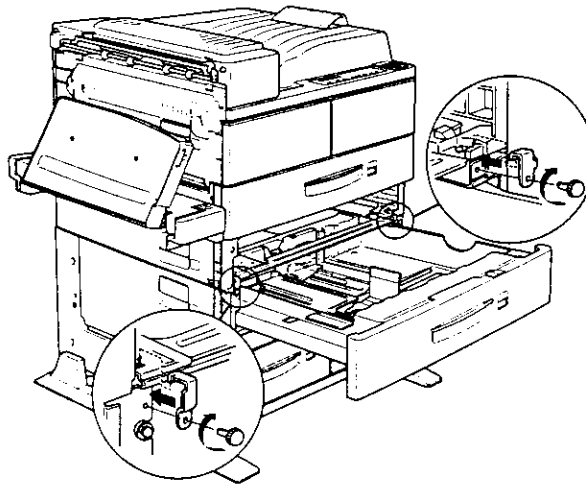

5. Push cassette 3 back into the unit, then replace cassette 2.
6. Pull out cassette 4 and remove the protective materials inside.

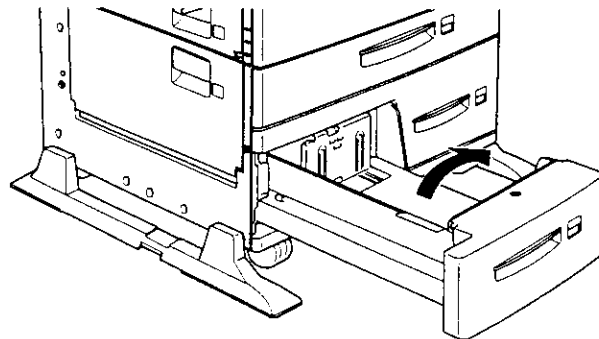

4. Carefully lift the printer with two or more people.

**Caution:**

- The printer weighs about 50 kg (110.2 lb); always lift it with two or more people.
- Grasp the printer at the locations indicated below.

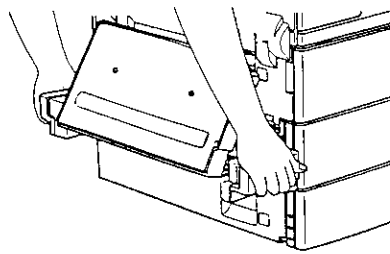

left side

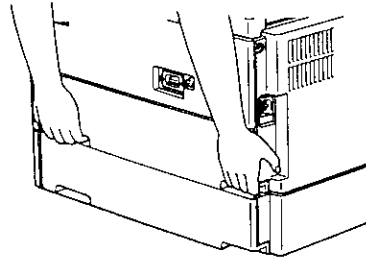

right side

5. Align each of the corners of the printer with those of the unit, then lower the printer until it rests securely on the unit.



4. Open the box with the Large Capacity Paper Unit. Cut the tape that holds the cardboard inserts.

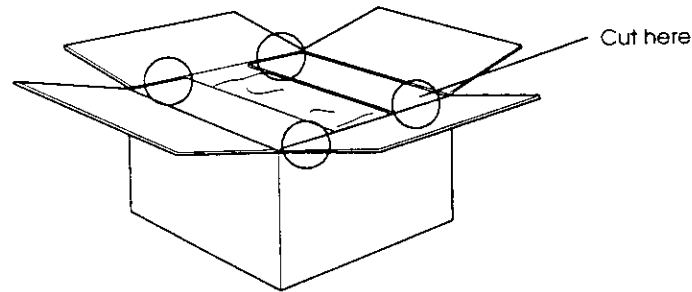

5. Remove the inserts and all other protective materials inside. Make sure the contents of the package match the items on the included document.

**Note:**

*Remove the packaging materials and any other items from the printer and store them for future use.*

### Installing

1. Carefully lift the Large Capacity Paper Unit out of the box with two or more people, and place it near the printer.

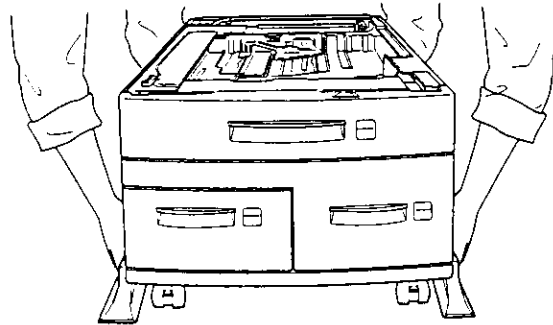

---

## Printer Options

You can add to your printer's capabilities by installing any of the following options:

- The Large Capacity Paper Unit (C81303\*). Fits directly beneath the printer and increases paper feeding capacity for most sizes of paper up to A3. Supported paper sizes are shown below.

Lower Cassette 3  
A3, A4, Ledger, Legal, GLG, Letter, Executive

Lower Cassette 4 or 5  
A4, Letter, Executive

**Note:**

The asterisk (\*) is a substitute for the last digit of the product number, which varies by country.

- The Duplex Unit (C81304\*). Prints on both sides of paper. Supported paper sizes are shown below.

A3, A4, A5, Ledger, Legal, GLG, Letter, HLT, GLT,  
Executive, F4

- The Multibin Unit (C81305\*). Can be used as a mailbox, a sorter, or a large capacity stacker. Output capacity of 1000 printed sheets. Supported paper sizes are shown below.

A3, A4, A5, Ledger, Legal, GLG, Letter, HLT, GLT,  
Executive, F4

- The Face-up Tray (C81306\*). Ejects paper with printed side up. Output capacity of 200 printed sheets. Supported paper sizes are shown below.

A3, A4, A5, Ledger, Legal, GLG, Letter, HLT, GLT,  
Executive, F4

L

**Flamingo  
Rev. C**

A5 size CONPANE.FM

7/16/98 Pass 0

Proof Sign-off:

M.Takata \_\_\_\_\_

K.Nishi \_\_\_\_\_

K.Pipa \_\_\_\_\_

## **OneTouch mode 2**

To enter OneTouch mode 2, press the SelectType button (repeatedly if necessary) until the indicator light next to RITech comes on, indicating the printer is in OneTouch mode 2. The current OneTouch mode 2 settings for RITech, Copies, MP Tray Size, and Toner Save Mode are shown on the display in this order.

### *RITech*

Turns the RITech setting on or off. RITech produces smoother and crisper lines, text and graphics. If you change this setting, you can check the print quality with the RITech setting by printing a status sheet from the SelectType Test Menu.

### *Copies*

Specifies the number of copies to be printed, up to 999.

### *MP Tray Size*

Allows you to set the paper size for the MP Tray. If you use the optional Envelope Feeder, you can set the paper size for the Envelope Feeder, instead.

### *Toner Save Mode*

Turns the Toner Save Mode on or off. When turned on, the printer saves toner by substituting a gray shade for the black inside characters. The characters are outlined in full black on the right and lower edges.

## **Making OneTouch settings**

To make OneTouch settings, access one of the modes as described above and press the button located under the setting you want to change to cycle forward through the available options. You can also cycle backward through available options by holding down ALT (SelectType) while pressing the button under the setting you want to change.

L

**Flamingo  
Rev. C**

A5 size CONPANE.FM

7/16/98 Pass 0

Proof Sign-off:

M.Takata

K.Nishi

K.Pipa

\_\_\_\_\_

\_\_\_\_\_

\_\_\_\_\_

Enter  
(Status  
Sheet)

Selects the corresponding OneTouch mode option listed above this button if in OneTouch mode 1 or 2, or accepts the setting currently shown on the display as a new setting when in SelectType mode. Press this button two times when the printer is on line to print the status sheet.

Form Feed

When the printer is off line and data remains in the printer's memory (Form Feed light is on), prints out the data and clears the buffer.

Continue  
(Reset)

Enables the printer to resume printing after certain maintenance-required conditions or errors have been cleared. If the Continue light is flashing, read the status or error message on the display and correct the problem as described in "Status and Error Messages" on page 5-23. If used in combination with the ALT button, the printer is reset.



OneTouch  
mode 2

On when the printer is in OneTouch mode 2. For details on OneTouch modes, see "Using the OneTouch Modes" on page 2-7.

<input type="checkbox"/>	RTech	Copies	MP Tray Size	Toner Save Mode
--------------------------	-------	--------	--------------	-----------------

SelecType

On when the printer is in SelecType mode. For more information on the SelecType mode, see Chapter 4, "SelecType".

<input type="checkbox"/>	Menu	Item	Value	Enter
--------------------------	------	------	-------	-------

**Buttons**

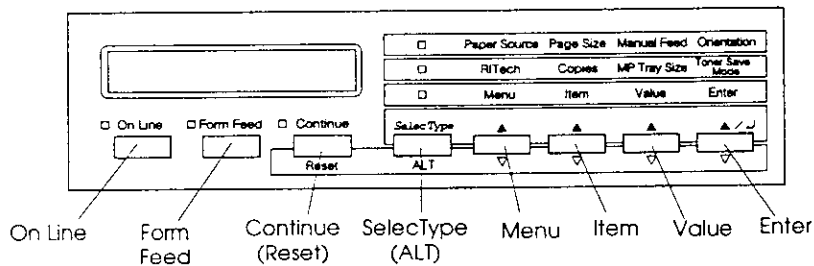

On Line

Switches the printer between on-line and off-line status.

---

## **The Control Panel**

This chapter shows you how to use the control panel.

Being familiar with your printer's control panel will help you use your printer more effectively. The OneTouch modes are also described here.

### **Overview**

The printer control panel gives you simple control over most common printer operations. The panel is made up of three elements: a liquid crystal display, indicator lights, and buttons. The display and indicator lights tell you the current status of the printer, and you can use the printer buttons to select settings and functions. However, software settings usually override these settings.

### **Display**

The display shows the following:

- Status messages, such as **Warming Up**, indicating the printer's current status.
- Error messages, such as **Paper Out**, identifying maintenance procedures you must perform or error conditions you need to correct.
- SelectType** options, such as **Emulation**, allowing you to control printer modes, font selection, paper handling, and several other printer functions.

### **Offset stacking mode**

The offset stacking mode allows you to separate print jobs, or multiple copies of your document, by alternating their position in the face-down tray as shown below.

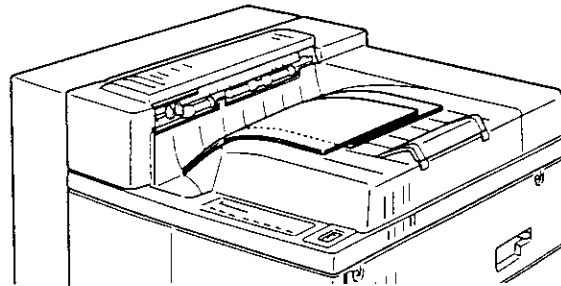

The offset stacking mode supports the following paper sizes.

A3, A4, Ledger, Legal, GLG, Letter, Executive

Select the offset stacking mode in one of the following ways.

#### **Using the printer driver**

Select the offset stacking mode on the printer driver. For more information on using the printer driver, see the driver's online help.

#### **Using the SelecType**

For information on selecting the offset stacking mode with the SelecType settings, see "Printing Menu" on page 4-8.

#### **Note:**

*The offset stacking mode only works with the face-down tray. If you print in stacker mode, printouts on the optional Multibin Unit, if installed, are not offset.*

### **Selecting the paper size**

By default, the printer driver is set for A4 size paper to be loaded. If you load paper of a different size, change the paper size setting using one of the following methods.

#### **Using the printer driver**

Choose the paper size on the Basic Settings menu. For more information on using the printer driver, see the driver's online help.

#### **Using SelecType**

For information on changing the paper size with the SelecType settings, see Chapter 4, "Printing Menu".

---

## **Special Printing Operations**

### **Loading an uncommon paper size**

To load paper with an uncommon or custom paper size, from 100 × 148 mm (3.9 × 5.8 in.) to 297.4 × 431.8 mm (11.7 × 17 in.), use the MP Tray and make the size settings in one of the following methods.

- Access the printer driver, click User Defined Size inside the Basic Settings menu. Type the Paper Width, Paper Height, and Unit settings to match your custom paper. Then click OK to save your custom paper size.
- Access the SelecType mode using the control panel on your printer (see Chapter 4, "Using SelecType") and set the page size to CTM (custom).

4. Fan a stack of paper and tap it on a flat surface to even the edges. Insert the paper face up into the cassette, placing the corners of the paper on the arrow mark inside the cassette.

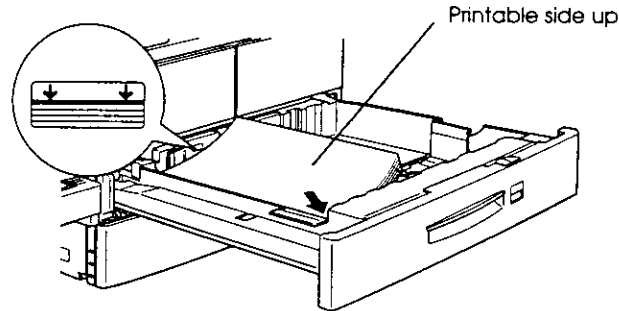
**Note:**

*Be sure not to load paper higher than the arrow mark.*

5. Adjust the vertical and horizontal paper guides to match the size of your paper.

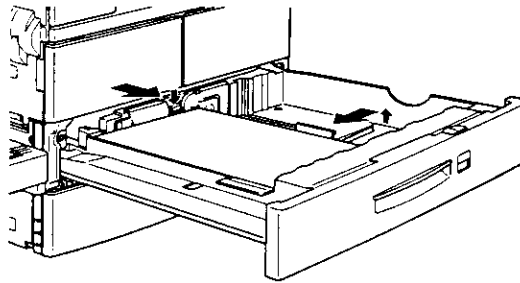
**Caution:**

*Make sure to adjust the paper guides to the paper size you load; otherwise, the printer will not print properly.*

### Loading paper in the lower cassettes

Lower cassettes 1 and 2 accommodate various types and sizes of paper. These cassettes are useful for loading paper that you use regularly or in large amounts. Each cassette handles 500 sheets allowing you to load a total of 1000 sheets. Refer to the tables below to load your paper with the correct orientation in the appropriate cassette.

#### Lower Cassette 1

Loading Orientation	Paper Size
Vertical	A4, A5, Executive, Letter, Half-Letter
Horizontal	A3, Ledger, Legal, Government Legal

#### Lower Cassette 2

Loading Orientation	Paper Size
Vertical	A4, Executive, Letter
Horizontal	A3, Ledger, Legal, Government Legal

To confirm paper sizes, see Appendix A, 'Paper Specifications'.

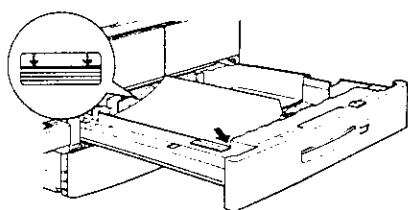

Vertical loading orientation

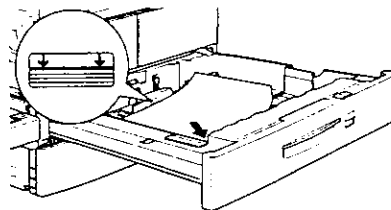

Horizontal loading orientation



**Caution:**

*You cannot print on envelopes using the lower cassettes.*

## Printing Operation

This section covers how to use the standard paper sources. See Chapter 3, "Options" for information on optional paper sources and output trays.

### Loading paper in the MP (Multi Purpose) Tray

The MP Tray handles up to 50 sheets and accommodates various types and sizes of paper. This tray is useful when printing on paper that you don't regularly use. Refer to the table below to load your paper with the correct orientation.

Loading Orientation	Paper Size
Horizontal	A4, B5, A5, Letter, Government Letter, Half-Letter, International B5
Vertical	A3, B4, F4, Ledger, Legal, Government Legal, Executive

To confirm paper sizes, see "Paper Specifications" in Appendix A.

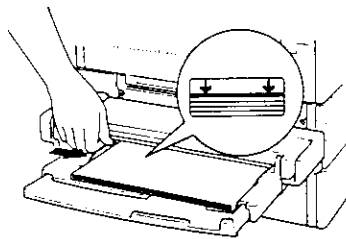

Horizontal loading orientation

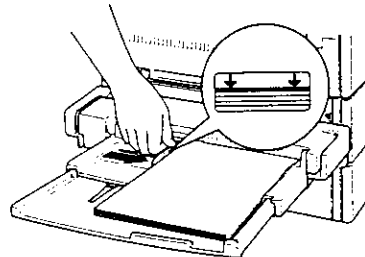

Vertical loading orientation



**Caution:**

*Always use the optional envelope feeder when you print on envelopes of sizes other than International B5.*

L

**Flamingo  
Rev. C**

A5 size  
7/16/98

LOADING.FM  
Pass 0

Proof Sign-off:

M.Takata

K.Nishi

K.Pipa

\_\_\_\_\_  
\_\_\_\_\_  
\_\_\_\_\_

---

### **Precaution for printing**



**Caution:**

*Do not turn off the printer:*

- If the On Line light is not on.*
- While the On Line light is blinking.*
- While the Form Feed light is on or blinking.*

---

### **Choosing Paper**

**Note:**

*Since the quality of any particular brand or type of paper may be changed by the manufacturer at any time, EPSON cannot guarantee the quality of any type of paper. Always test samples of paper stock before purchasing large quantities or printing large jobs.*

You can use many kinds of media including stock paper, envelopes, labels, and overhead projector transparencies. The printer automatically feeds most types of media from the MP (Multi Purpose) Tray, except for envelopes. This section describes each paper feed, which one to use, and how to select and load paper.

The type of paper you use in your printer can affect the quality of your printed output. The smoother the paper you use, the smoother and sharper your printing looks.

For best results, store your paper supply in its original wrapper. Your printout can be marred by moisture absorbed in the paper. Do not store paper in a humid or damp environment.

Below are some recommendations for selecting paper and other print media for the printer.



L

**Flamingo  
Rev. C**

A5 size  
7/16/98

INTRO.FM  
Pass 0

Proof Sign-off:  
M.Takata  
K.Nishi  
K.Pipa

\_\_\_\_\_  
\_\_\_\_\_  
\_\_\_\_\_

- The blue wire must be connected to the terminal in the plug marked with the letter N.
- The brown wire must be connected to the terminal in the plug marked with the letter L.

If damage occurs to the plug, replace the cord set or consult a qualified electrician.

Replace fuses only with a fuse of the correct size and rating.

---

### **Warnings, Cautions, and Notes**



*Warnings must be followed carefully to avoid bodily injury.*



*Cautions must be observed to avoid damage to your equipment.*

*Notes contain important information and useful tips on the operation of your printer.*

L

**Flamingo  
Rev. C**

A5 size  
7/16/98

INTRO.FM  
Pass 0

Proof Sign-off:

M.Takata \_\_\_\_\_

K.Nishi \_\_\_\_\_

K.Pipa \_\_\_\_\_

- Use the type of power source indicated on the label. If you are not sure of the type of power available, consult your dealer or local power company.
- If you are unable to insert the plug into the outlet, contact your electrician to have your outlet repaired or replaced.
- Do not put your printer where the cord might be stepped on.
- Avoid using outlets that other appliances are plugged into.
- Only use an outlet that meets the power requirements for this printer.
- Never push objects of any kind through cabinet slots as they may touch dangerous voltage points or short out parts which could result in fire or electric shock. Never spill liquid of any kind on the printer.
- Except as specifically explained in this guide, do not attempt to service this product yourself. Opening or removing covers that are marked "Do Not Remove" exposes you to dangerous voltage. Refer all servicing in those compartments to service personnel.
- Unplug the printer from the wall outlet and refer servicing to qualified service personnel under the following conditions:
  - A. If liquid has been spilled into it.
  - B. If it has been exposed to rain or water.
  - C. If it does not operate normally when the operating instructions are followed. Adjust only those controls that are covered by the operating instructions since improper adjustment of other controls may result in damage and will often require extensive work by a qualified technician to restore the product to normal operation.
  - D. If it has been dropped or the cabinet has been damaged.

- Protect the light-sensitive drum from exposure to light. Avoid exposing the imaging cartridge to room light any longer than necessary. Do not open the drum's protective cover. Overexposing the drum may cause abnormally dark or light areas to appear on the printed page and reduce the service life of the drum.

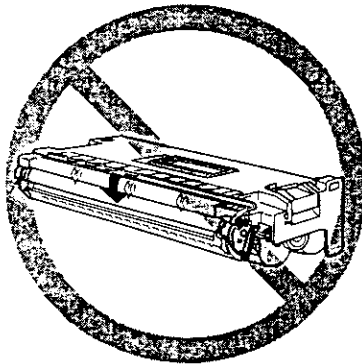

- When handling the cartridge, always set it on a clean, smooth surface.
- Do not attempt to modify or take apart the cartridge. It cannot be refilled.
- Do not touch the toner and avoid all contact with your eyes.
- Wait for at least one hour before using a cartridge after moving it from a cool to a warm environment.

**Warning:**

*Do not dispose of used imaging cartridges in fire, as they can explode and cause injury. Dispose of them according to local regulations.*

## ***Ozone safety***

### *Ozone emission*

Ozone gas is generated by laser printers as a by-product of the printing process. Ozone is produced only when the printer is printing.

### *Ozone exposure limit*

The recommended exposure limit for ozone is 0.02 parts per million (ppm) expressed as an average time-weighted concentration over an eight (8) hour period.

The EPL-N4000 laser printer generates less than 0.01 ppm for 8 hours of continuous printing in a closed room of approximately 1000 cubic feet (8' × 10' × 12').

### *Minimize exposure risk*

To minimize the risk of exposure to ozone:

- Do not use more than one laser printer in a confined area (see *Ozone exposure limit* above)
- Do not use your printer in conditions of extremely low humidity
- Do not use your printer in a room with poor ventilation
- Avoid long, continuous printing in any of the conditions mentioned above

### *Printer location*

The printer should be located so that the exhaust gases and generated heat are:

- Not blown directly into the user's face
- Vented directly out of the building whenever possible

---

## **Safety Information**

### **Laser safety**

This printer is certified as a Class 1 laser product under the U.S. Department of Health and Human Services (DHHS) Radiation Performance Standard according to the Radiation Control for Health and Safety Act of 1968. This means that the printer does not produce hazardous laser radiation.

Since radiation emitted by the laser is completely confined within protective housings and external covers, the laser beam cannot escape from the machine during any phase of user operation.

### **For European users**

#### *United Kingdom*

The EPL-N4000 is a page printer which utilizes a semiconductor laser.

There is no possibility of danger from the laser, provided the printer is operated according to the instructions in the guides provided.

Since radiation emitted by the laser is completely confined within protective housings, the laser beam cannot escape from the machine during any phase of user operation.



**Warning:**

*Use of controls or adjustments or performance of procedures other than those specified in this guide, may result in hazardous radiation exposure.*

This is a semiconductor laser. The maximum power of the laser diode is 5 mW and the wavelength is 775 to 795 nm.

---

## **ENERGY STAR Compliance**



As an ENERGY STAR Partner, EPSON has determined that this product meets the ENERGY STAR guidelines for energy efficiency.

The International ENERGY STAR Office Equipment Program is a voluntary partnership with the computer and office equipment industry to promote the introduction of energy-efficient personal computers, monitors, printers, fax machines, copiers, and scanners, in an effort to reduce air pollution caused by power generation.

---

## **About Making Printer Settings**

You need to make some settings for your printer before printing. There are three ways you can make these settings:

- Using your printer driver (software that runs or “drives” your printer)
- Using the OneTouch modes (control panel shortcuts that allow you to make several settings quickly)
- Using SelecType (control panel functions that allow you to make even more settings than the printer driver)

If you use a Windows application, use the printer driver that came with the printer to make settings. For details on your printer driver, see the driver’s online help.

If you cannot make all the settings you need through the Windows printer driver, use the OneTouch modes and SelecType.

### **Wide variety of fonts**

The printer comes with a full selection of scalable TrueType® fonts, LaserJet-compatible scalable fonts, and one bitmap font in LJ4 emulation mode, to provide you with the fonts you need to create professional-looking documents.

### **Toner Save mode**

You can reduce the amount of toner used when printing rough drafts by using the Toner Save mode.

### **Options**

#### Memory

The printer comes with 16 MB of memory, which can be expanded to up to 256 MB.

#### Interface

The printer comes with a built-in bidirectional parallel interface and a built-in Ethernet interface. You can install an optional Type-B interface.

#### Rom module

The Adobe® PostScript® 3™ Kit (C83232\*) ROM module generates crisp PostScript output. Installation instructions are included in this *Reference Guide*. See also the PostScript Kit's documentation.

#### **Note:**

The asterisk (\*) is a substitute for the last digit of the product number, which varies by country.

---

## About This Guide

This guide contains the following information.

Chapter 1, "Printing with the EPL-N4000," contains information on main printing operation. Also consult this chapter when you need information about printing on special media.

Chapter 2, "Control Panel," explains the contents of the printer's control panel and how to use the OneTouch Modes.

Chapter 3, "Options," gives step-by-step instructions for installing the printer options. Also describes how to use the options.

Chapter 4, "SelecType," describes the settings you can make in SelecType on the control panel. Read this chapter if you cannot modify a printer setting from your software.

Chapter 5, "Troubleshooting and Maintenance," gives helpful information for what to do if you encounter a printer error and provides instructions on how to maintain your printer.

Appendix A, "Technical Specifications," contains technical information about your printer and options.

Appendix B, "Symbol Sets," lists the symbol sets available in each emulation mode with tables of the characters for each set.

Appendix C, "Command Summary," lists the commands that can be embedded in print jobs to control the printer. This appendix is intended for advanced users only.

Appendix D, "Working with Fonts," describes the steps you need to follow to add more fonts. It also lists the available fonts with samples.

Appendix E, "Map of SelecType Menus," lists the SelecType menus and the order in which you access them. This appendix is useful when you use SelecType.



L

**Flamingo  
Rev. C**

A5 size  
7/16/98

FLAMINGO.TOC  
Pass 0

Proof Sign-off:  
M.Takata  
K.Nishi  
K.Pipa

\_\_\_\_\_  
\_\_\_\_\_  
\_\_\_\_\_

---

**Appendix A Technical Specifications**

---

Paper Specifications .....	A-2
Printer .....	A-3
General .....	A-3
Environmental .....	A-4
Mechanical .....	A-4
Electrical .....	A-5
Interface .....	A-5
Parallel interface .....	A-5
Ethernet Interface .....	A-11
Options and Consumables .....	A-12
Large Capacity Paper Unit (C81303*) .....	A-12
Duplex Unit (C81304*) .....	A-13
Multibin Unit (C81305*) .....	A-13
Face-up Tray (C81306*) .....	A-14
Envelope Feeder (C81307*) .....	A-14
Imaging Cartridge (S051060) .....	A-15

---

**Appendix B Symbol Sets**

---

Introduction to Symbol Sets .....	B-2
In LJ4 Emulation Mode .....	B-3
International Set for ISO sets .....	B-21
In ESC/P 2 or FX Modes .....	B-22
International character sets .....	B-26
Characters available with the ESC (^ command) .....	B-27
In I239X Emulation Mode .....	B-28
In EPSON GL/2 Mode .....	B-28

---

**Appendix C Command Summary**

---

LaserJet 4 (LJ4) Emulation Commands .....	C-3
GL/2 context commands .....	C-6
ESC/P 2 and FX Commands .....	C-9
ESC/P 2 mode .....	C-9
FX mode .....	C-12
PJL Commands .....	C-15

---

**Chapter 2 Control Panel**

---

The Control Panel .....	2-2
Overview .....	2-2
Display .....	2-2
Indicator lights .....	2-3
Buttons .....	2-4
Using the OneTouch Modes .....	2-7
OneTouch mode 1 .....	2-7
OneTouch mode 2 .....	2-8
Making OneTouch settings .....	2-8

---

**Chapter 3 Options**

---

Printer Options .....	3-2
Installing and Removing Options .....	3-3
Large Capacity Paper Unit .....	3-3
Duplex Unit .....	3-10
Face-up tray .....	3-16
Envelope feeder .....	3-28
Multibin Unit .....	3-32
Memory modules .....	3-47
ROM module .....	3-52
Optional interfaces .....	3-54
Using the Options .....	3-57
Large Capacity Paper Unit .....	3-57
Duplex Unit .....	3-58
Face-up tray .....	3-58
Envelope feeder .....	3-60
Multibin Unit .....	3-61

---

**Chapter 4 Selectype**

---

When to Use Selectype .....	4-2
Using Selectype .....	4-2
Selectype Menus .....	4-3
Selectype Settings .....	4-6
Test Menu .....	4-6

Proof Sign-off:  
M.Takata  
K.Nishi  
K.Pipa

Flamingo  
Rev. C

NO SIZE  
7/16/98

OPTIONS.FM  
Pass 0

R

## FCC Compliance Statement For United States Users

This equipment has been tested and found to comply with the limits for a Class B digital device, pursuant to Part 15 of the FCC Rules. These limits are designed to provide reasonable protection against harmful interference in a residential installation. This equipment generates, uses, and can radiate radio frequency energy and, if not installed and used in accordance with the instructions, may cause harmful interference to radio or television reception.

However, there is no guarantee that interference will not occur in a particular installation. If this equipment does cause interference to radio and television reception, which can be determined by turning the equipment off and on, the user is encouraged to try to correct the interference by one or more of the following measures.

- ▶ Reorient or relocate the receiving antenna.
- ▶ Increase the separation between the equipment and receiver.
- ▶ Connect the equipment into an outlet on a circuit different from that to which the receiver is connected.
- ▶ Consult the dealer or an experienced radio/TV technician for help.

### WARNING

The connection of a non-shielded equipment interface cable to this equipment will invalidate the FCC Certification of this device and may cause interference levels which exceed the limits established by the FCC for this equipment. It is the responsibility of the user to obtain and use a shielded equipment interface cable with this device. If this equipment has more than one interface connector, do not leave cables connected to unused interfaces. Changes or modifications not expressly approved by the manufacturer could void the user's authority to operate the equipment.

### For Canadian Users

This Class B digital apparatus complies with Canadian ICES-003.

Cet appareil numérique de la classe B est conforme à la norme NMB-003 du Canada.

