

BUSINESS PRINTER

BP-9000

OWNER'S MANUAL

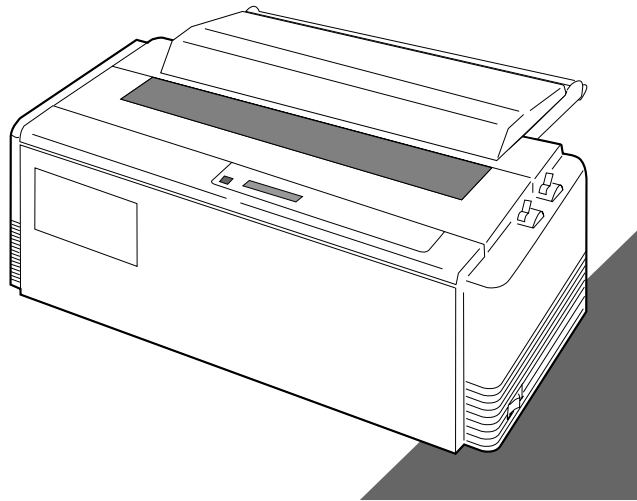

Warning

"This equipment has been tested and found to comply with the limits for a Class B digital device, pursuant to Part 15 of the FCC Rules. These limits are designed to provide reasonable protection against harmful interference in a residential installation. This equipment generates, uses, and can radiate radio frequency energy and, if not installed and used in strict accordance with the instructions, may cause harmful interference to radio communications. However there is no guarantee that interference will not occur in a particular installation. If this equipment does cause harmful interference to radio or television reception, which can be determined by turning the equipment off and on, the user is encouraged to try to correct the interference by one or more of the following measures:

- Reorient the receiving antenna
- Increase the separation between the equipment and receiver.
- Connect the equipment into an outlet on a circuit different from that to which the receiver is connected.
- Consult the dealer or an experienced radio/TV technician for help.

"It is necessary to use shielded interconnect cables to insure compliance with FCC Class B limits for radio frequency emissions."

Caution: Changes or modifications not expressly approved by the party responsible for compliance could void the user's authority to operate the equipment.

This manual and the program samples described in it are copyrighted by SEIKO Precision Inc. with all rights reserved. No part of this publication may be reproduced, stored in a retrieval system, or transmitted, in any form or by any means, mechanical, photocopying, recording or otherwise, without the prior written permission of SEIKO Precision Inc.

- * HP is a registered trademark of HEWLETT-PACKARD Company.
- * PCL is a registered trademark of HEWLETT-PACKARD Company.
- * DeskJet 500/RuggedWriter 480 are a registered trademark of HEWLETT-PACKARD Company.
- * Epson is a registered trademark of S.Epson Corporation.
- * LQ-2550 is a registered trademark of S.Epson Corporation.
- * IBM is a registered trademark of International Business Machines Corporation.
- * IBM2931 is a registered trademark of International Business Machines Corporation.
- * Windows is a registered trademark of Microsoft Corporation.



OWNER'S MANUAL

24-pin wide-carriage
dot matrix printer

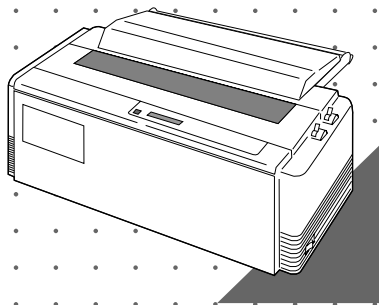

As an ENERGY STAR Partner, SEIKO Precision Inc. has determined that this product meets the ENERGY STAR guidelines for energy efficiency.

- Outline of the International ENERGY STAR Office Equipment Program -

The International ENERGY STAR Office Equipment Program is an international program that promotes energy saving through the use of computers and other office equipment. The program backs the development and dissemination of products with functions that effectively reduce energy consumption. It is an open system in which business proprietors can participate voluntarily. The targeted products are office equipment such as computers, displays, printers, facsimiles, and copiers. Their standards and logos uniform among participating nations.

SEIKO Precision Inc.

© 1999 SEIKO Precision Inc.

This manual is for the following two models of the printer.

Although these two models, model A and model B, look different, the difference is only the appearance of the casing areas at the front. The functions of these models are very much the same.

Refer to the manual of the model A, for the manual of the model B.

Model A

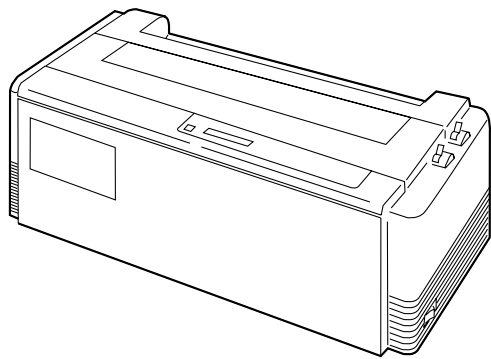

Model B

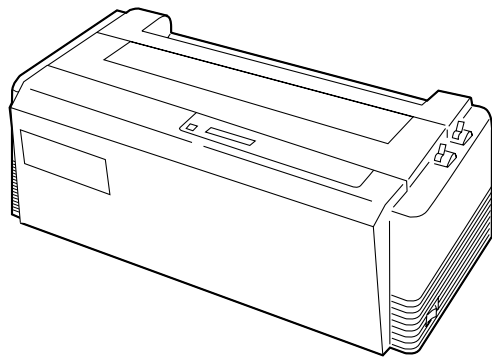

Contents

Unpacking the printer.....	1
Quick startup.....	2
1. Introduction	
Features.....	3
Options and expendables.....	4
Printer description.....	6
2. Setting up	
Installing the paper rack	10
Installing the sound seal cover	10
Installing the ribbon cassette	11
Connecting the computer	12
Connecting the power cord	12
Loading the paper.....	13
Adjusting print head position	15
3. Control panel and operations	
Control panel and indicators	16
Paper parking.....	20
Printing test pattern	21
Demonstration print-out	22
Tearing off a form.....	22
Power-on operation summary	23
4. Basic setup options	
About basic setup options	24
Printing multipart paper	26
Selecting page length for fanfold paper.....	26
Selecting single sheet paper size	27
Selecting font style.....	28
Selecting character spacing	29
Enlarging/compressing print	30
Setting top of form position	31
Loading user setup options	31
5. Extended setup options	
About extended setup options	33
Print enhancement	
10 Emulation.....	36
11 Character table (HP mode).....	36
12 Character table (Epson mode).....	37
13 Character table (IBM mode).....	37
14 National font style.....	38
15 Code page.....	38
16 IBM Alternate graphic mode.....	39
17 Carriage return (CR).....	39
18 Line feed (LF).....	39
19 Line feed spacing.....	40
20 Slashed zero.....	40
21 Set default tab stops.....	40
22 Lock-in the page length.....	40
23 Print quality	41
24 Lock-in the font.....	41
25 Lock-in the character spacing	41
26 Lock-in the print quality.....	41
Barcode print enhancement	
27 Enable barcode print	42
28 Barcode type.....	42
29 Bar code size.....	44
30 Enlarged character size.....	44
31 Graphic Print Speed.....	45
32 Accent character.....	45
33 Setting of the FF code at TOF	45
HP mode enhancement	
38 PCL mode	46
39 Secondary character table	46
Paper handling enhancement	
40 Set the top margin.....	47
41 Set the bottom margin	47
42 Set the left margin.....	47
43 Set the right margin	48
44 Fanfold paper width	48
45 Autoscroll delay.....	48
46 Override bottom margin	49
47 Label mode.....	49
48 Paper out detection.....	50
49 Cut sheet feeder type.....	50
50 Setting of the auto scrolling position	50
51 Line Feed Speed.....	51
Communication enhancement	
60 Interface type.....	51
61 SELECT IN signal.....	51
62 Parity bits.....	51
63 Data length.....	52
64 Stop bit.....	52
65 Communication protocol	52
66 Communication speed	52
67 Serial error check	53
68 CTS signal.....	53
69 CD signal	53
70 DSR signal.....	53
71 Communication buffer size	54
72 Busy/ACK timing.....	54
73 Data latch timing.....	54
74 Setting of whether ERROR/PE signals are output or not	54
Miscellaneous	
80 Print direction.....	55
81 LCD display language.....	55
82 Invert LCD display	55
83 Software controlled setup	56
84 Lock the RESET key.....	56
85 Setting of ENERGY STAR	56
86 Saving user setup options	56
87 Printing list of option settings	56

6. Setting the application software	
About printer driver	57
Printer driver selection	57
Connecting the BP-9000 printer	
in the HP Environment	58
Saving Your Setup.....	59
7. Troubleshooting	
Error messages	60
Troubleshooting guide	61
Input hexadecimal dump mode	62
8. Maintenance	
Cleaning.....	63
Lubrication.....	63
Printer cover removal	64
Vertical alignment mode	66
9. Bar code and enlarged character function	
● Bar code function	
Outline of bar code function.....	69
Makeup of bar code.....	69
Bar code command list.....	70
(1) Bar code type.....	70
(2) Element width.....	71
(3) Bar code height.....	71
(4) Setting HRI on and off.....	71
(5) HRI font.....	72
(6) Check character.....	72
(7) Starting the bar code data sequence... ..	72
(8) Ending the bar code data sequence... ..	73
(9) Bar code data sequence.....	73
(10) Printing density.....	73
(11) Guide bar expansion.....	73
(12) Start and stop characters.....	74
(13) Barcode rotational angle.....	74
(14) Disabling HRI of the start	
and stop characters.....	74
(15) Value input mode.....	74
(16) Initializing the bar code mode... ..	75
◇ Data processing in the bar	
code data sequence.....	75
◇ Printing bar codes.....	76
◇ HRI.....	76
◇ Error processing.....	77
◇ Code 128 subset transition rule.....	77
◇ UPC-E conversion rule.....	78
◇ Calculating the check character.....	78

◇ Other.....	80
◇ Element printing.....	80

● Enlarged character function	
Outline of enlarged	
characterfunction.....	82
Enlarged character	
command list.....	82
(1) Executing backspacing.....	83
(2) Executing line feeding.....	83
(3) Executing form feeding.....	84
(4) Executing carriage return.....	84
(5) Initializing the enlarged	
character mode.....	84
(6) Arrangement of enlarged	
characters.....	85
(7) Cell magnification for	
enlarged characters.....	85
(8) All-character set for	
enlarged characters.....	86
(9) Selecting an enlarged	
character font.....	86
(10) Height expansion for	
enlarged characters.....	87
(11) HMI for enlarged characters.....	87
(12) VMI for enlarged characters.....	88
(13) Setting and canceling the	
enlarged character mode.....	88
(14) Enlarged character cell offset.....	89
(15) Enlarged character pitch.....	89
(16) Enlarged character quality.....	90
(17) Enlarged character rotational angle..	90
(18) Setting and canceling enlarged	
character smoothing..	91
(19) Enlarged character top offset.....	91
(20) Setting and canceling underlining	
of enlarged characters... ..	92
(21) Enlarged character	
widthwise expansion.....	92
(22) Horizontal printing position	
for enlarged characters... ..	93
(23) Vertical printing position for	
enlarged characters..	93
◇ Enlarged character print samples.....	94

Appendices

A.	Specifications	
	Printing specifications	95
	Parallel interface specifications	100
	Serial interface specifications	101
	Other specifications	102
B.	Control code summary	
	IBM mode	103
	Epson mode	109
	PCL mode	115
	Setup options control codes	122
C.	Character sets.....	127
D.	Reverse control panel	136

Caution for use

❑ Power source

- Be sure to insert the power plug only in a wall unit of the voltage designated in the voltage selector switch and on the rating plate on the back of the unit.
- Do not place the power cord near heat sources or place heavy objects on it. Do not bend or twist the power cord.

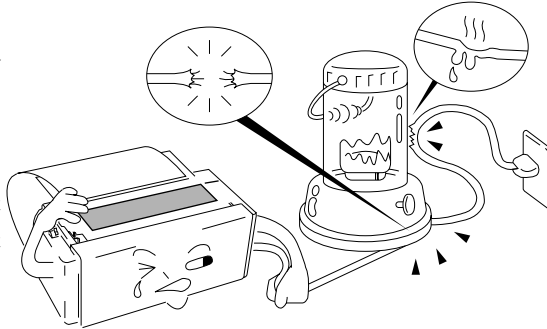

❑ Foreign matter and water

- Keep your hands and personal items, such as scarfs and ties, away from the carriage mechanism while the printer is operating. The carriage moves with considerable force.
- Keep the printer dry. If you accidentally spill water on the machine, turn the power off immediately and wipe it dry. Do not turn the power on until the machine is completely dry.

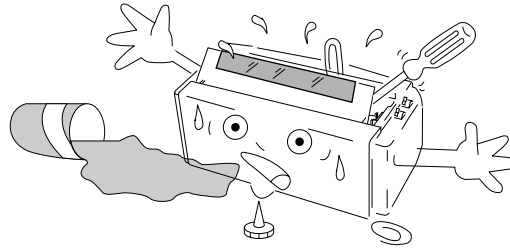

❑ Installation environment

- The printer should be used where humidity is low, where there is little dust, and where the printer is not in direct sunlight.
- Avoid placing or leaning anything on top of the printer. If you accidentally drop any object into the machine, turn the power off immediately, then carefully remove the object.
- Do not twist the ribbon while installing it.

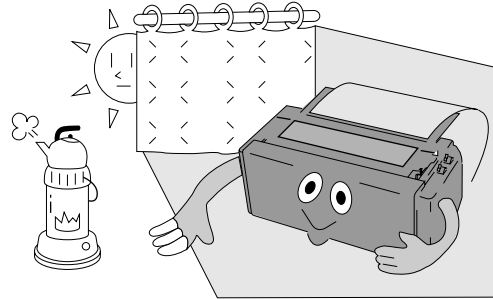

❑ Operating condition

- Wait at least two seconds after turning power off before turning it back again. The initialization process may not be performed correctly if this is not done.
- Do not touch the print head immediately after printing because it is too hot.
- Never operate the printer without paper or paper properly installed.
If you use paper that is not as wide as the platen, be sure that printing does not exceed paper width. Use software control to change the width of the print line.
- Never insert or pull out an interface cable while the power to the printer and computer is on.
- Be sure to turn off the printer before turning off a connected host computer.

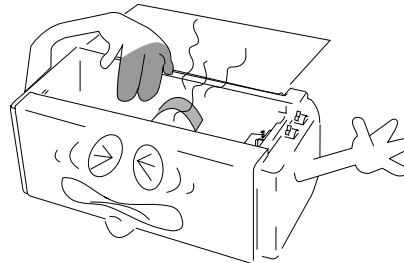

Unpacking the printer

Check the cartons for the following items:

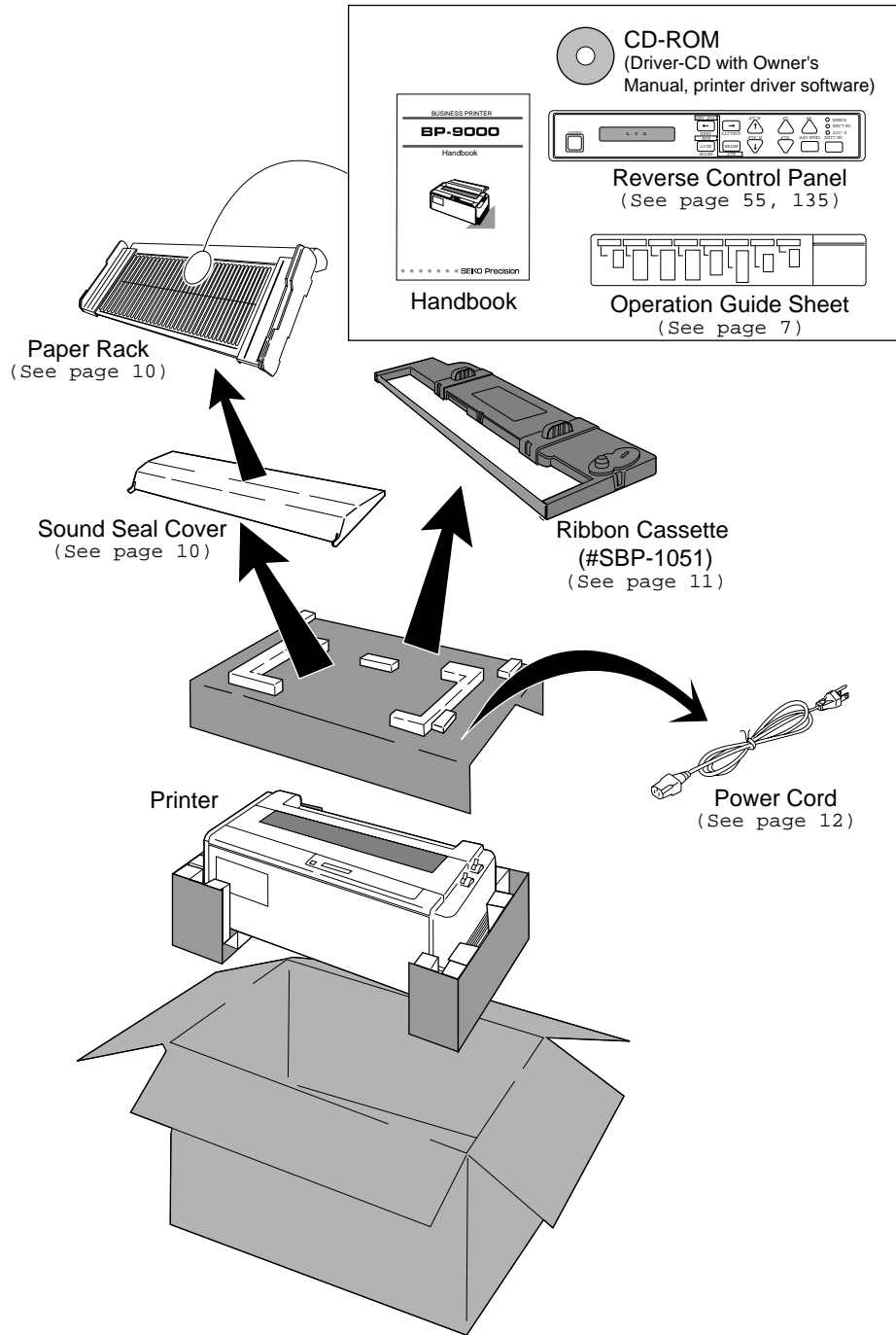

Quick startup

To make your first print, follow the procedure below . For more detailed instructions on setting your printer, please refer to the page indicated.

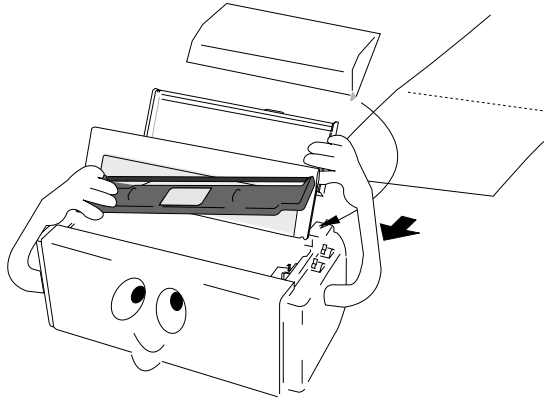

❑ To set up the printer

1. Install the paper rack, the sound seal cover, and the ribbon cassette — Pages 10 and 11.
2. Load the single cut sheet paper or fanfold paper. Press the FF key to load the paper — Pages 13 and 14.

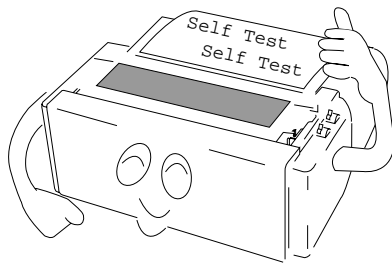

❑ To make a test print

1. Set the paper size of the printer in the setup options — Pages 26 and 27.
2. Press the LF key and hold while initializing the printer by the RESET key. Hold the LF key until the self test starts — Page 21.

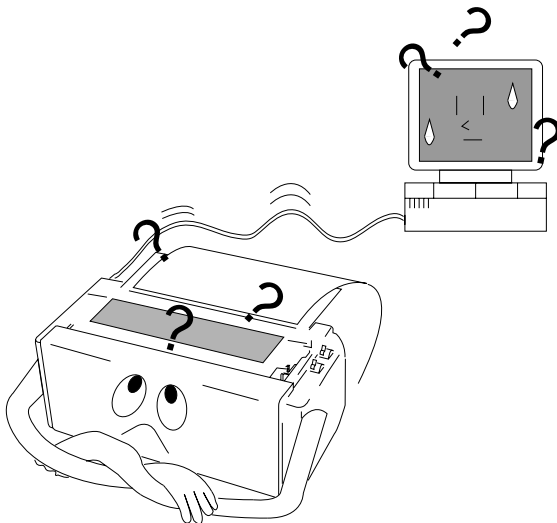

❑ To connect your computer

1. With all equipment turned off, connect the printer to your computer. Interface cable is purchased separately — Page 12.
2. Use the extended setup options (emulation type and communication enhancement section) to match the specification needs between the printer and your computer — Pages 33 to 56.
3. Select the printer driver from your application software — Page 57.

1. Introduction

Features

❑ Barcode Print available

- 13 resident barcode type Industrial 2/5, Interleave 2/5, Codabar, Matrix 2/5, Code 11, Code 39, Code 93, Code 128, EAN-8, EAN-13, UPC-A, UPC-E, Postnet

❑ Enlarged character printing

Characters can be enlarged (by up to 127 times as large x 127 times as large) using the enlarged character command unique to this printer. Software commands are used for control.

❑ Contain the 3 kind of emulations

Compatible to major printer emulations, Hewlett Packard, IBM and Epson printers.

- Hewlett Packard Rugged Writer 480 (PCL3) compatible
- EPSON LQ-2550 compatible
- IBM 2391 compatible

❑ Wide selection of paper size

- Single cut sheet papers A3, A4, B4, B5, Letter, Legal
- Fanfold continuous paper 5 - 15 inch wide and 2 - 16.5 inch long paper
- Multi-part paper Original plus 8 copies
(total clearance: 0.635mm (0.025"))
- Labeling paper Label peel-proof capability

❑ Full option of font types and variation of character spacings

- 10 resident fonts Courier, Prestige, Script, OCR-A, OCR-B, Gothic, Orator, Orator-S, Roman, and Sans Serif
- 8 character spacings 10, 12, 15, 16.7, 17.1, 20, 24 characters per inch (CPI), and proportional and 1/2 proportional characters

❑ Enlarge/reduce your layout to fit in any paper size

- you can print the same layout of the document in different paper size.

❑ Easy operation

- Multiple display language for international use.
- Upside down display enables operation from the back of the printer.

❑ Superb compatibility and connectability

- Communication protocols adjustable to any computer.
- Interface connections provided for parallel, RS-232C.
- Parallel and serial interface are switched automatically when "AUTO" setting is selected.

Options and expendables

The Cut Sheet Feeder greatly enhances the speed and efficiency of document printing by feeding of up to 80 single sheets of paper without reloading.

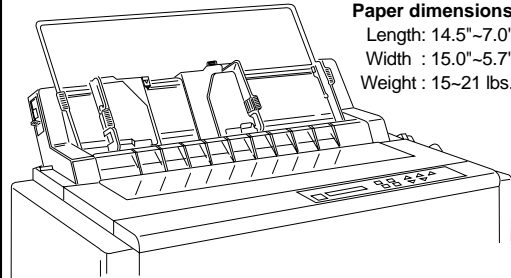

Paper dimensions
Length: 14.5"-7.0"
Width : 15.0"-5.7"
Weight : 15-21 lbs.

Cut Sheet Feeder
1 Bin (#BP-78009)
2 Bin (#BP-78009E)

The Pull Tractor is recommended for applications using extra thick forms.

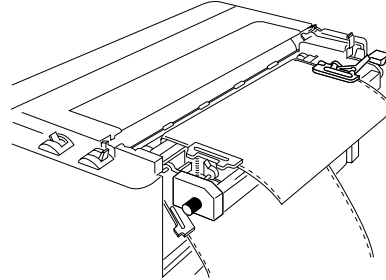

Pull Tractor (#BP-57008)

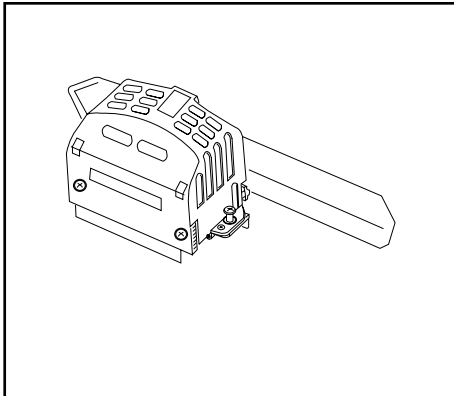

Matrix Print Head

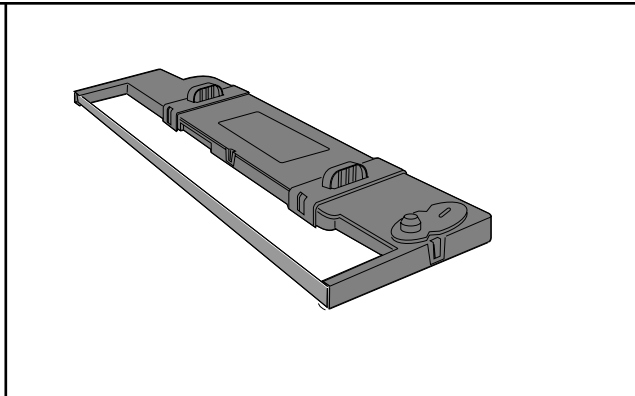

Ribbon Cassette (#SBP-1051)

❑ **Power cord**

One of the following plug types is supplied. See "Connecting the power cord" on page 12.

Please see the rating plate on the back of your printer for appropriate input voltage and consult your dealer for a specific type of power cord, if necessary.

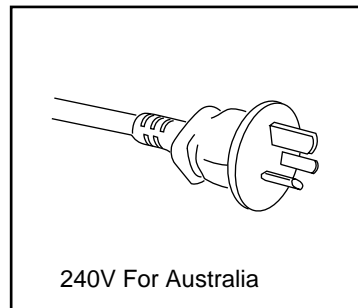
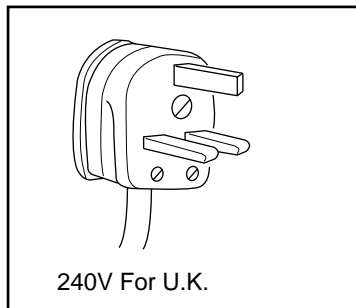
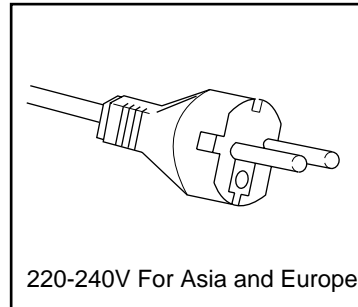
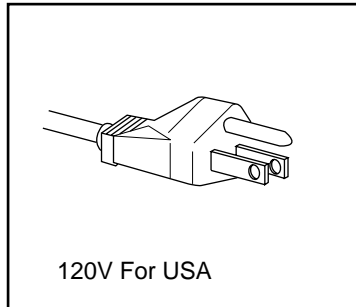

Printer description

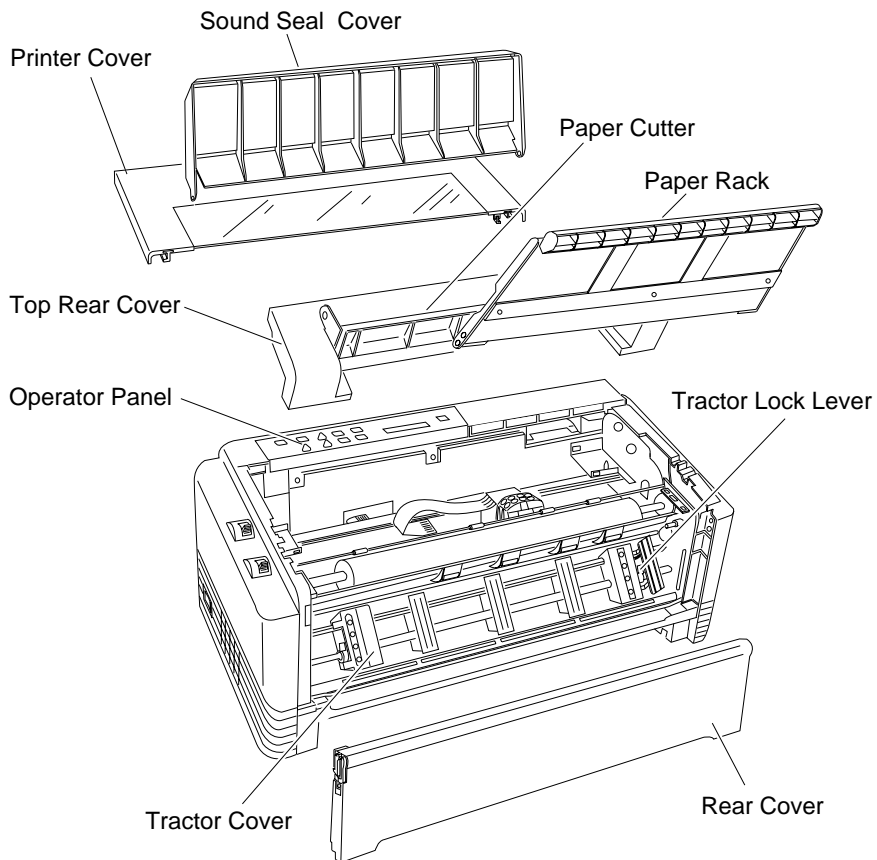
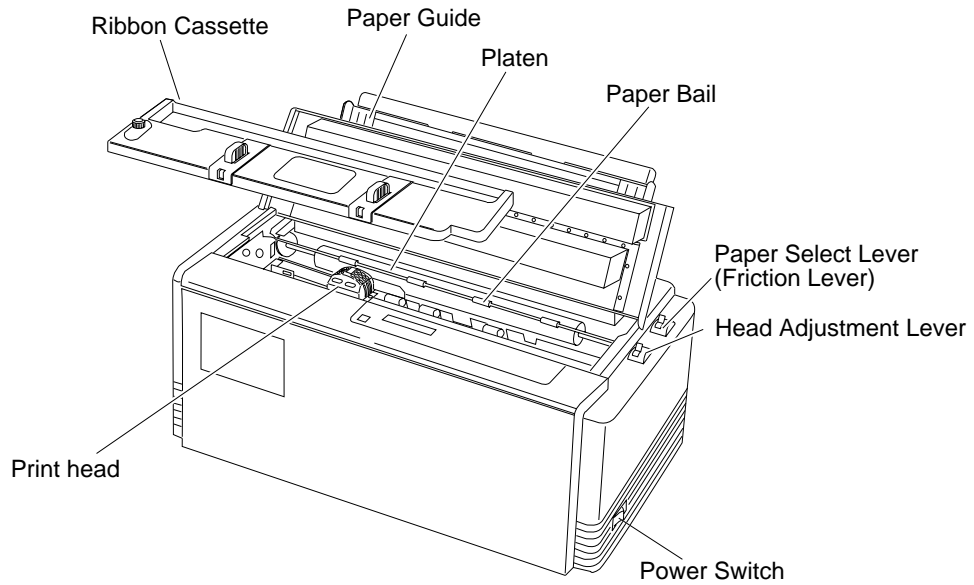

❑ Operation guide sheet

The operation guide sheet helps you to operate some of the basic options on the front control panel. You can peel the adhesive backed paper and stick it anywhere on your printer for convenience.

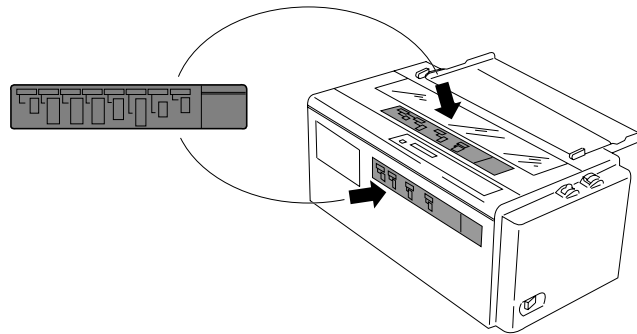

❑ Precaution for extra-thick paper usage

Extra-thick continuous paper, especially 9-part multi-layer paper may get jammed in the printer due to its stiffness and inflexibility. When using such paper, set the paper rack in the slant position shown in the figure.

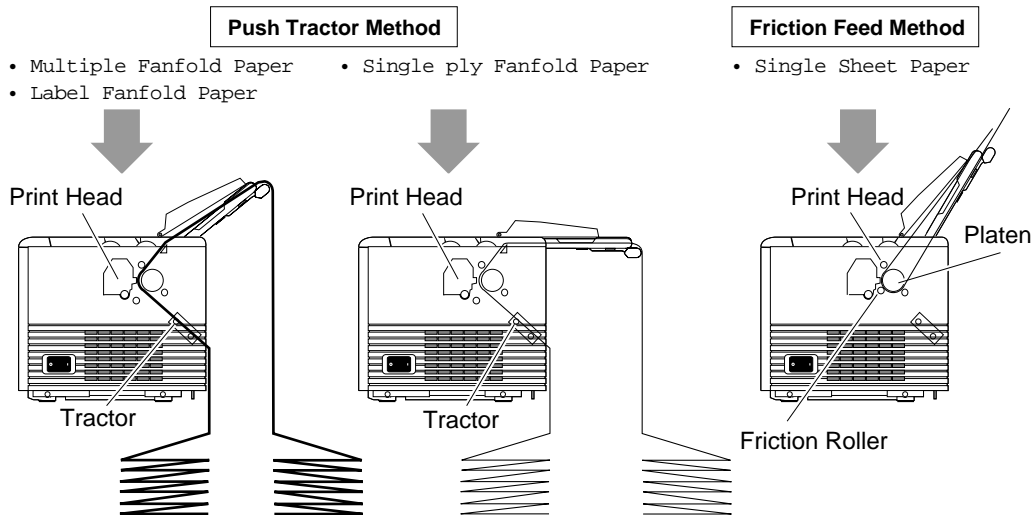

Fanfold Paper

Description	Single-ply	Multiple Copies	Label Paper
Paper width	5~15 inch		
Paper length	2~16.5 inch		
Ply	single	Original+8 max.	single
Total thickness	0.065~0.12mm	0.635mm max.	0.18mm max.
Paper weight	14lbs.~28lbs. 53g/m ² ~105g/m ²	non-carbon	125Kg max.

Single Sheet Paper

Description	Single-ply
Paper size	A3, A4, B4, B5 Letter, Legal
Ply	single
Total thickness	0.08~0.12mm
Paper weight	17lbs.~28lbs. 64g/m ² ~105g/m ²

□ Physical dimension(Model A)

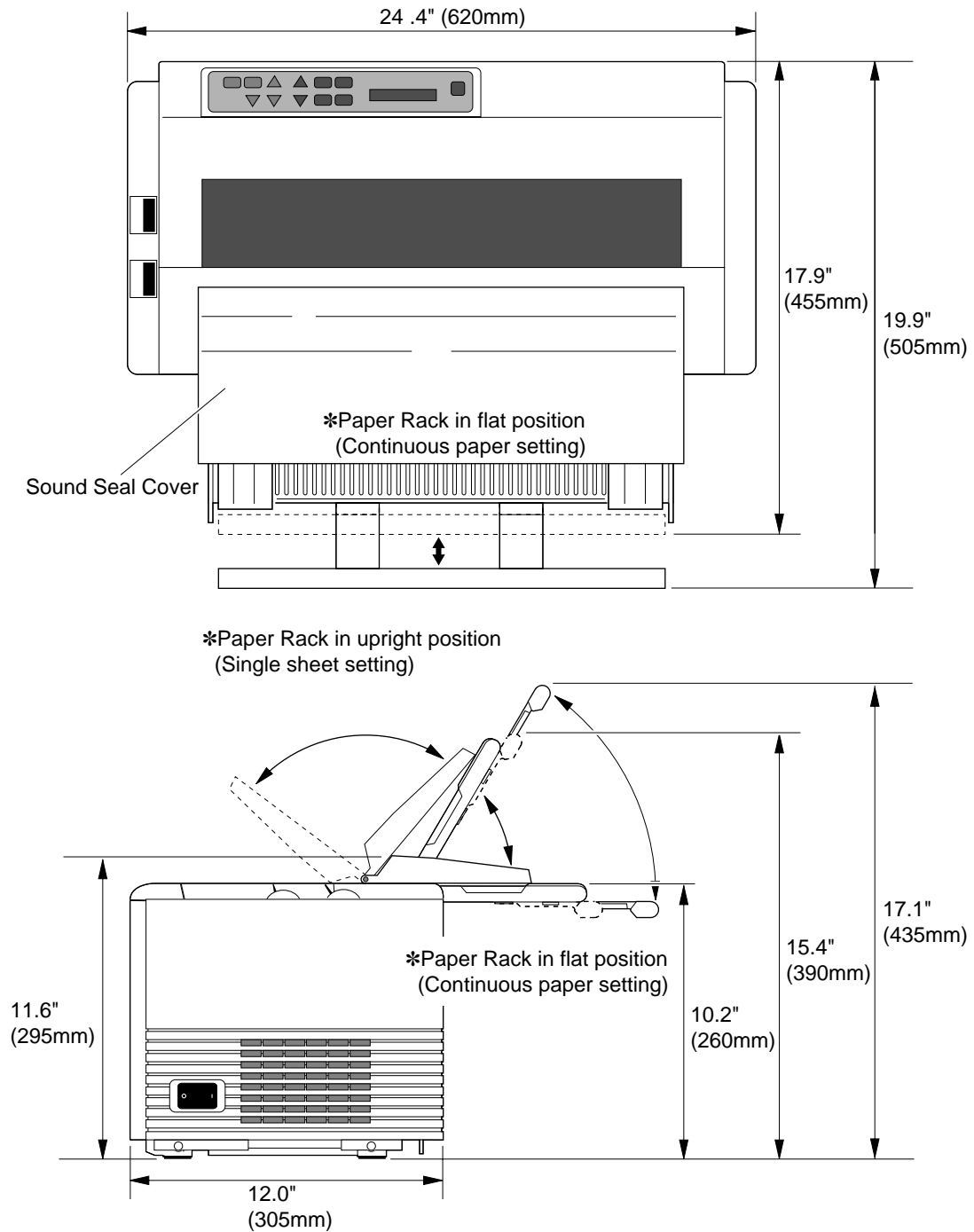

Weight: 44.1 lbs. (20 kg)

□ Physical dimension(Model B)

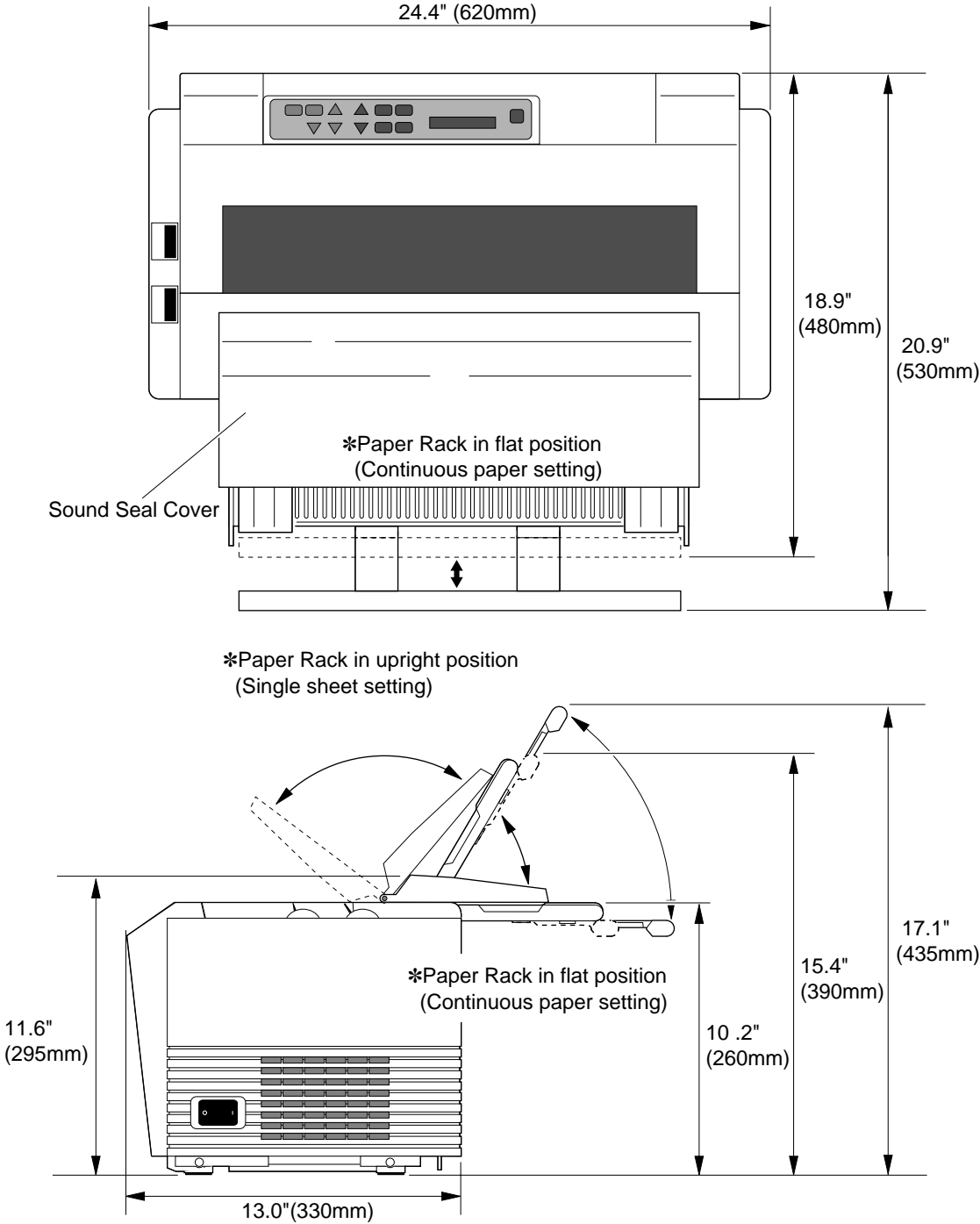

Weight: 44.1 lbs. (20 kg)

2. Setting up

Installing the paper rack

1. Slide both paper guides to the extreme left and right edges of the paper rack.
2. With the two small pivots on either side of the paper rack downward, fit the pivots in the groove on the rear top cover.
3. Place the paper rack in upright position for single cut sheet paper and lay it down for fanfold continuous paper.

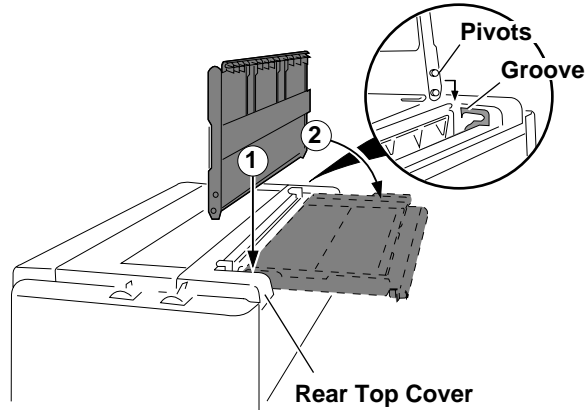

Note

The paper guides should be placed to the outside edges during the installation or removal of the paper rack.

Installing the sound seal cover

1. Lay the sound seal cover upside down on the printer.
2. Fit one of the holes of the cover to the stud of the L-angle hinge on one side of the printer.
3. Fit the other hole to the other stud by pressing the L-angle hinge inward then out through the hole.

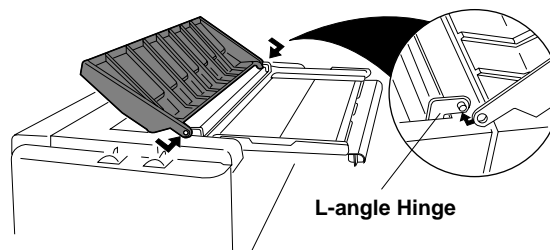

Note

Make sure that both studs are out through the hole completely, otherwise, the sound seal cover will be stuck in place.

Installing the ribbon cassette

Turn OFF the printer's power and remove the used ribbon cassette, if necessary, by pulling straight upward.

1. Open the printer cover.
2. Manually move the print head to the extreme right side of the printer for easy installation of the ribbon. Do not try to move the print head if the power is on.

CAUTION

Do not touch the print head if the printer has been running for a long time. Wait until the print head is cooled off.

3. Turn the ribbon feed knob in the direction of the arrow on the knob to remove any slack in the ribbon.

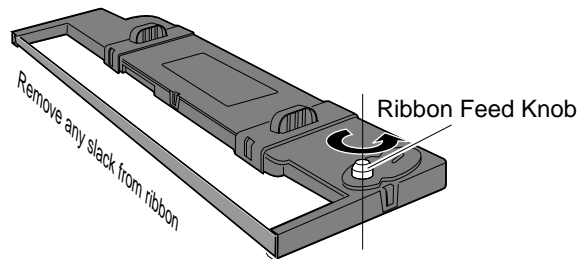

4. Place the ribbon cassette on the left and right cassette holders, such that the ribbon rests on the ribbon guide. Check to be sure that the ribbon drive shaft on the left cassette holder is inserted in the hole on the bottom of the ribbon cassette.
5. Turn the ribbon feed knob in the direction of the arrow on the knob to remove any slack in the ribbon.
6. Replace the front printer cover and set the head adjustment lever to the proper position for the best print quality.

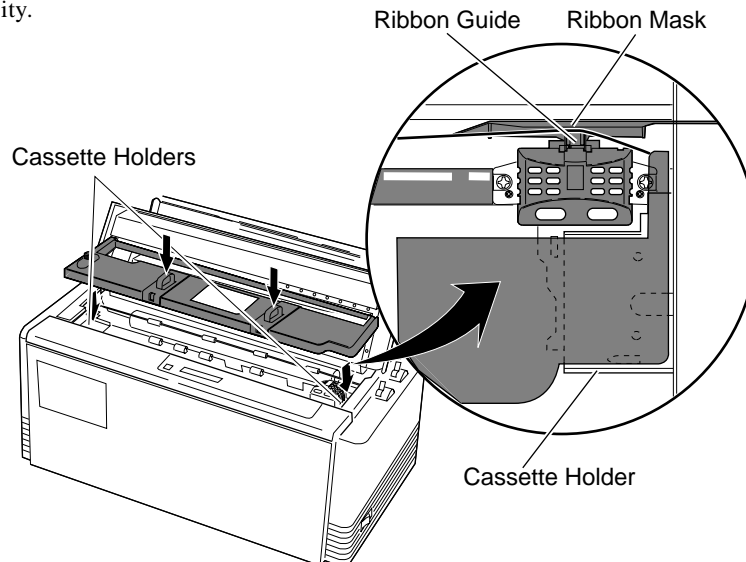

Connecting the computer

The printer has a parallel interface connector (Centronics) and a serial interface connector (RS232C). Before you connect an interface cable to your computer, you need to know what type of printer driver is supported by your software applications and what type of connector is needed to attach the printer to the computer.

□ Parallel Interface 36-pin plug

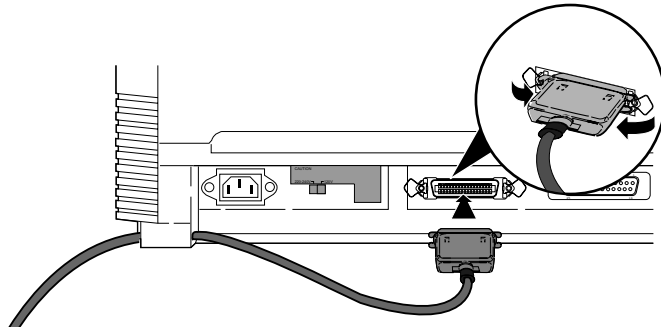

□ Serial Interface 25-pin plug

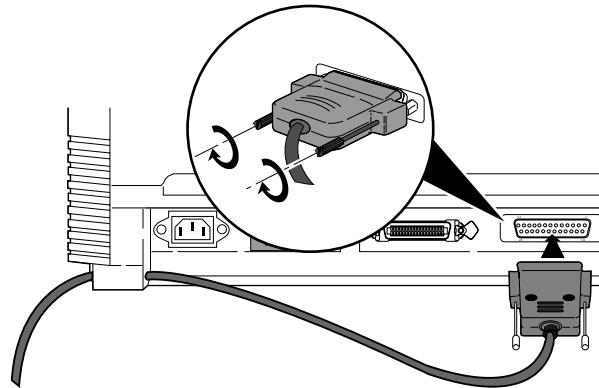

Connecting the power cord

Check the power requirement printed on the rating plate on the rear of the printer before attaching the power cord and turning on the printer. Both **POWER** and **P.OUT** lamps light up when the printer is switched on correctly. The voltage selector should be set correctly as follows.

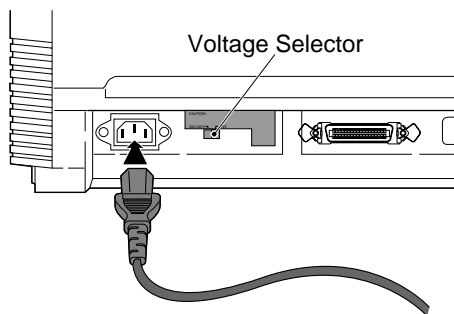

120V:USA, Canada
230V:Europe,Asia, Oceania

Note

For continued protection against risk of fire and destruction of Power PCB Assembly, switch the voltage selector according to using voltage.

Loading the paper

❑ Fanfold continuous paper

1. Move the paper select lever ① toward the front of the printer to set the fanfold paper setting.
2. Set the print head adjustment lever ② . In general, position 1 is used for one-part paper. (See page 15)
3. Remove the rear cover ③ of the printer or open the rear cover to lock the cover in the open position.
4. Release the tractor lock levers ④ (upward), and move the right tractor to the marked position as shown in the figure, and lock it in place.
5. Open both tractor covers ⑤ and place the fanfold paper so that the tractor pins are aligned with the holes in the paper. Carefully close both tractor covers.

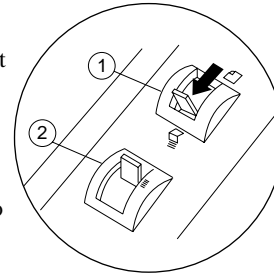

Caution

Be careful not to catch your finger when closing the tractor covers.

6. After the paper is properly installed, re-adjust the left tractor to a position to keep the paper taut (but not too taut) between the left and right tractors.
7. To load the paper, press the **PARK** key or **FF** key on the front panel. The fanfold paper is fed to the top-of-form position 14/60 inch (6mm) below the top edge of the paper. The top-of-form position can be adjusted from 0/60 inch to 480/60 inches (8 inches = 203mm) in the basic setup options on page 31.
8. The paper bail automatically lowers to press the paper against the platen when the leading edge of the paper feeds more than one inch onto the platen.

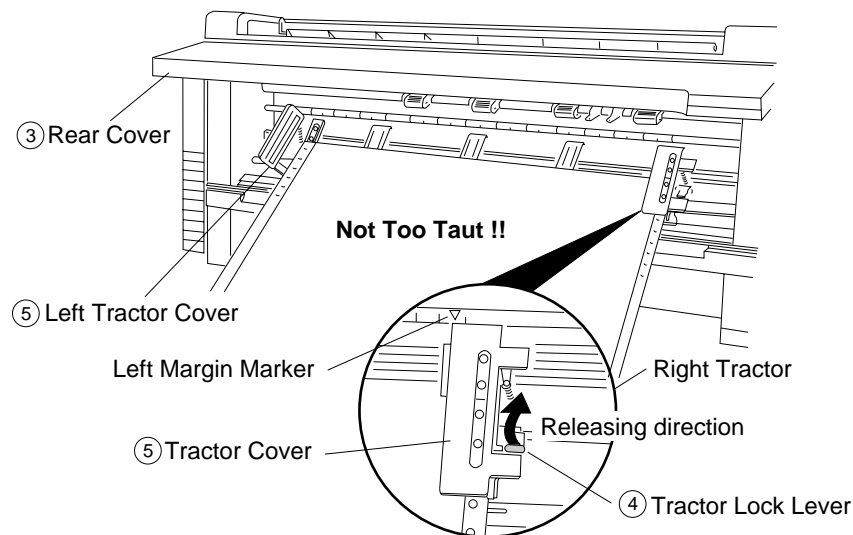

❑ Single sheet paper

1. Move the paper select lever ① toward the rear of the printer to the single sheet setting.
2. Set the print head adjustment lever ②. In general, position 1 is used for one-part paper. See page 15.
3. Raise the paper rack to the vertical position and adjust the left paper guide ③ to the proper position for the size of the paper being used.

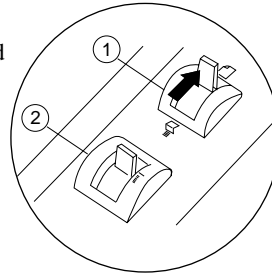

Note

If the paper is not loaded on the proper mark, the printer may not detect the paper and will issue PAPER ERROR.

4. Place single sheet paper against the paper rack and let it slide behind the platen.
5. Adjust the right paper guide ④ so that it comfortably holds the paper in between the two paper guides.

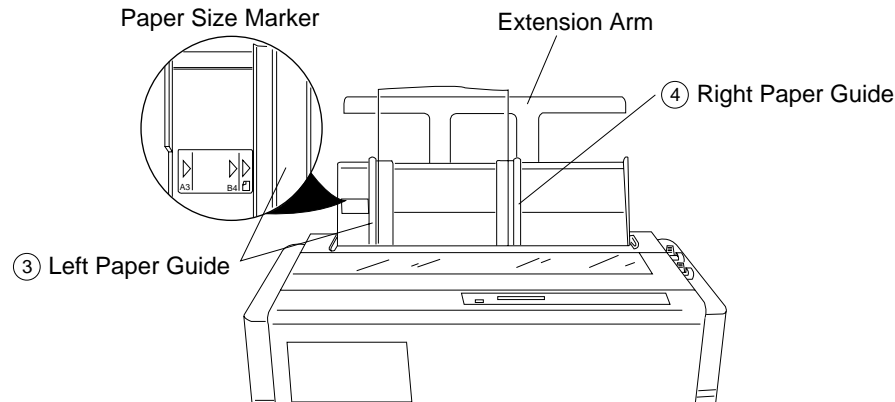

6. Press the **PARK** key or **FF** key to load the single sheet paper to the top-of-form position 14/60 inch (6mm) below the top edge of the paper. The top-of-form position can be adjusted from 0/60 inch to 480/60 inches (8 inches = 203mm) by using the front panel controls in the basic setup options on page 30.

Note

If the paper is not completely fed in, slightly push the paper downward. If it is still not fed in, look in the TROUBLESHOOTING section.

7. The paper bail automatically lowers to press the paper against the platen when the leading edge of the paper feeds more than one inch onto the platen.

Notes

1. Extension Arm

The extension arm is used to keep large size (Legal, B4) single sheets from falling behind the paper rack. When using the extension arm, pull the arm until it clicks and locks in place.

2. **TEAR OFF** keys are invalid with single sheet paper.

□ Paper alignment

Current print line location

The current printing line (DDD...) is the third line down from the top of the ribbon guide (line spacing is 1/6 line: 6 LPI).

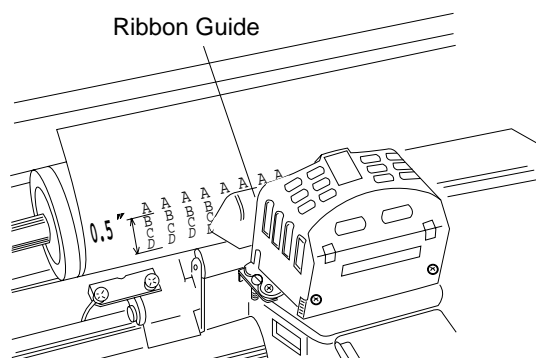

Adjusting the print head position

The head adjustment is used to obtain the best print quality possible for the specific paper being used. The print head position can be adjusted to accommodate printing on single and multipart forms. When using multipart forms, move the print head adjustment lever toward the front of the printer to widen the gap between the print head and the platen.

In general, position 1 is used for one-part paper. Moving the head adjustment lever one notch adjusts the print head gap an amount corresponding to the addition of one more paper part.

Re-adjustment of the lever may be required depending on the quality of the actual printout:

- If the ribbon smears on the paper, the gap is too narrow.
- If the printed image is too light to read, the gap is too wide.

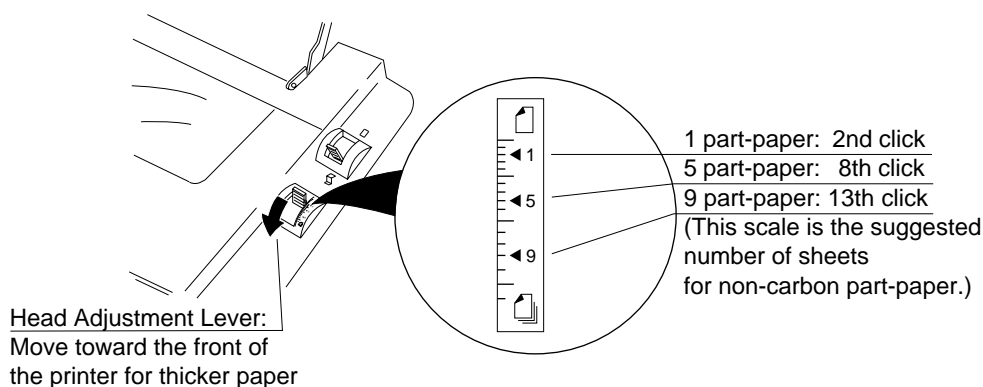

Notes

1. The print head adjustment lever should be set before loading the paper to avoid paper jams.
2. If the printed image on the last copy of a multipart form is too light to read, set the **MULTIPART** mode in the basic setup options (see page 26). This will increase the striking intensity on multipart forms.

3. Control panel and operations

Control panel and indicators

Standard Panel

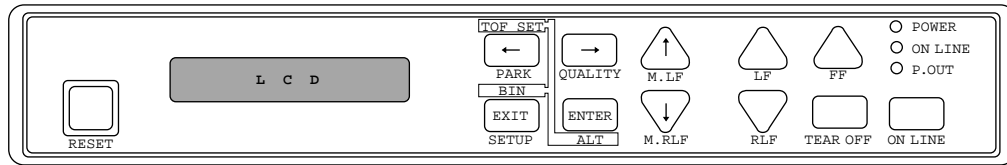

Alternate up-side down reverse panel

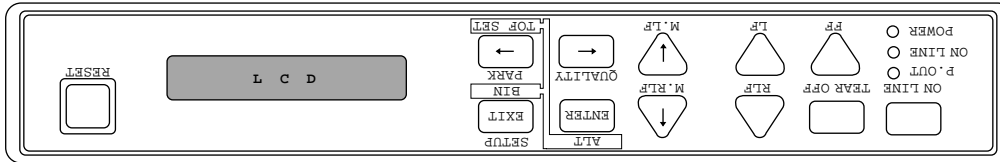

Note: The alternate reverse panel installation instruction is described in Appendix D.

❑ Indicators

- **Display window** Liquid Crystal Display (LCD)

Displays status and errors during operation and menus in the setup options.

The followings are some examples of the display messages.

P.OUT FANFOLD	Status message This indicates that the printer is in offline and paper out status.
---------------	--

COVER OPEN	Warning message This indicates that the printer cover is open. Close the cover to resume the operation.
------------	---

If the printer is in the offline mode, the following appears on the display.

FANFOLD 11×15	Status message for fanfold continuous paper This column indicates the page length; and the paper width. This indicates the type of paper selected is fanfold continuous paper.
---------------	---

MANUAL: A4 P	Status message for single sheets paper This indicates a paper size; B5 through A3 depending on the designated paper size (default A4) selected in the setup options. This indicates the type of paper selected is single sheet paper. MANUAL, BIN 1, BIN 2, BIN 1+2
--------------	---

- Indicator lamps

	Lamp	On	Off	Blinking
	POWER (green)	Power On	Power Off	—
	ON LINE (green)	Online	Offline	Cover open, or Head overheat protection activating
	P.OUT (amber)	Out-of-paper	Paper-in	Home sensor error, RAM error, or paper error.

Function Keys

- ON LINE



Pressing this key places the printer offline so that the printer can perform some functions independent from the host system. In the offline mode, data is not received. When the printer is offline, pressing the key places the printer online and ready to receive data from the host system.

- RESET



When the **RESET** key is pressed, the printer immediately enters the reset state and prepares for the initialize operation, which is nearly the same initialize operation as when the power is turned on.

The following keys are active only in the offline mode:

- LF/RLF

(Line feed and reverse line feed)

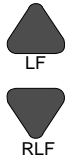

When the **LF/RLF** key is pressed, paper is fed per the line spacing at the 6 line per inch forward or backward, respectively.

While this key is pressed and held, the paper is continuously fed forward or backward, respectively.

- FF

(Form feed)



Pressing this key feeds the paper to the next top of form position. Single sheet paper is fed to eject.

3. Control panel and operations

- **M.LF/M.RLF**



(Micro line feed/micro reverse line feed)

When the **M.LF/M.RLF** key is pressed, the paper is fed 1/360 inch forward or backward, respectively. This key is used to set the paper position.

To set the **TOF SET** (top-of-form set) function, press the FF key and then simply advance the loaded paper forward or reverse to your desired print position using the **M.LF/M.RLF** keys. Hereafter until you reload paper, the first print position of the form is always fed at the same place.

- **TEAR OFF**



[Used only for fanfold paper]

Pressing this key advances the perforation of the form to the paper cutter so that the leading form can be torn off from the rest.

If this key is pressed after the form is torn off, the paper is fed backwards and the mode is returned to offline. If the **ON LINE** key is pressed instead of the **TEAR OFF** key, the paper is fed backwards and the mode is changed to the online mode.

- **PARK**



(Paper parking)

Pressing this key unloads the paper if the paper is already loaded and loads the paper when the paper is not already loaded.

Fanfold continuous paper (paper select lever in fanfold setting)

The paper is moved to the park station in the back of the printer by pressing this key. When pressing this key with the paper in the park position, the paper will be loaded to the print station between 0 and 8 inches from the top edge of the paper, depending on the loading position (TOF Adjust) selected in the basic setup options on page 31.

Single sheet paper (paper select lever in single sheet setting)

The paper in the print station will be ejected. When paper is in the paper rack, the paper is moved to the print station by pressing this key.

- **BIN**

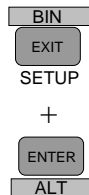

(ALT+SETUP keys)

This key is for selecting the active paper tray of the cut sheet feeder or the paper feed type:MANUAL, BIN1, BIN2 or BIN1+2. BIN1, BIN2, BIN1+2 appears only when the cut sheet feeder (CSF) option is set.

Note

The paper select lever must be switched to the single sheet setting.

• **TOF SET**

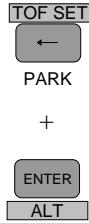

(ALT+PARK keys)

The TOF SET key is valid only when paper is loaded. When the TOF SET key is pressed in the offline state, the TOF position is set to the top of the ribbon guide, and the buzzer sounds.

After two seconds, the paper is fed backward so that the TOF position is at the current printing position.

When the TOF position is set, the setting of “7 TOF ADJUST” is changed to this set automatically.

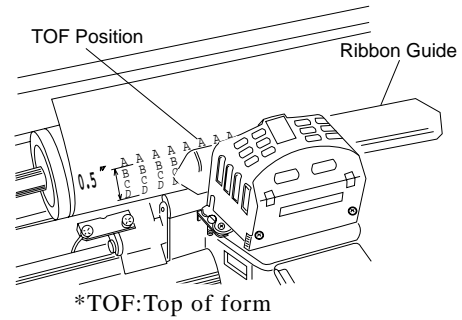

• **SETUP**



When the **SETUP** key is pressed the printer enters the setup options. The setup options are explained later in the "Basic setup options" section.

• **QUALITY**



This key is for selecting the print quality: LQ, NLQ, HQDR (high quality draft), DRAFT, SD (speed draft), or SSD (super speed draft). To set your desired print quality simply scroll and stop where your selection is displayed. The printer beeps once for an acknowledgment.

Software commands can override the print quality setting of this key. However, "#26 Quality Lock" option described on page 41 can lock-in the

LCD	ESC x 1 LQ is selected	ESC x 0 Draft is selected	Graphic print speed
LQ	LQ	Draft	Normal*
NLQ	NLQ	Draft	High speed 1
HQDR	LQ	HQDR	High speed 2
DRAFT	LQ	Draft	High speed 2
S.D.	S.D.	S.D.	High speed 2
S.S.D.	S.S.D.	S.S.D.	High speed 2

selection by this key and disable software commands.

This key also selects the graphic print speed.

*The graphic print speed is selected only by “31 GRAPHIC QUALITY” in the extended setup options.

• Others

The ←, →, ↓, ↑ **EXIT** and **ENTER** keys become effective only in the setup options entered by pressing the **SETUP** key. For more information refer to "Basic setup options."

□ **Control Levers**

• Head adjustment Lever

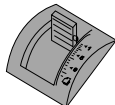

This lever adjusts the gap between the print head and the platen. The correct gap adjustment for a different paper thickness is required to obtain optimum print quality. See also page 15.

3. Control panel and operations

- Paper Select Lever

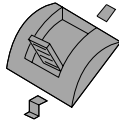

The paper select lever serves to switch between the fanfold continuous paper setting and the single sheet paper setting (or CSF setting when CSF installed).

Note: Switching this lever to continuous paper setting will mechanically release the pressure roller for single sheets and engage gear trains for continuous paper.

Paper parking

This function moves fanfold paper back to the push tractor position (park station) so that single sheet paper can be used. Specifically it is useful when switching from fanfold paper to single sheet paper.

- Pressing the **PARK** key removes the fanfold paper from the print station so that single sheet paper can be used.
- Switching of the paper select lever is required for the actual mechanical switching of the paper select.
- Pressing the **PARK** key when the printer is in the paper-out state loads the selected paper (fanfold or single sheet) to the top-of-form position.

The following table explains the paper handling of the **PARK** key in the offline state:

Friction Lever	P.OUT Indicator	Action
Continuous Paper	ON	Autoload the paper (similar to the FF key)
	OFF	Park the paper in the push tractor position
Single Sheets	ON	Autoload the paper (similar to the FF key)
	OFF	Eject the paper (similar to the FF key)

Notes

- 1. Make sure that the setting of the paper select lever corresponds to the type of paper being used.**
- 2. The paper park function causes PAPER ERROR in the following situations:**
 - a) when the fanfold paper is not set in the park station (at the push tractors) after moving more than 22 inches backward.**
 - b) when the paper (fanfold or single sheet) is not autoloading to the print station after feeding more than 8 inches. (At this time, the printer tries to sense the paper in the printer.)**
 - c) when single sheet paper is not ejected from the printer after advancing more than 22 inches.**

Printing test pattern

Before performing the printer's self test, be sure the ribbon cassette and paper are properly installed in the printer. The self test prints a continuous pattern of printable characters (ASCII character pattern) in either draft or letter quality (LQ).

While test printing is executed, the **ON LINE** lamp blinks and the LCD indicates "SELF TEST".

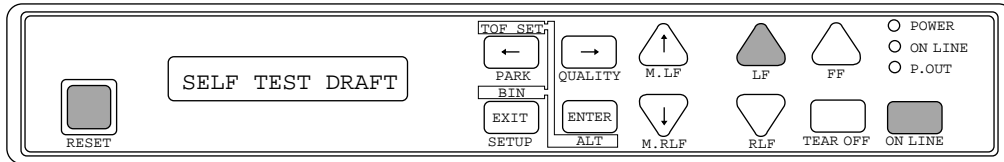

To run the draft self test

Press the **LF** key while turning ON the printer's power. If the printer is already turned ON, the draft self test may be performed by pressing the **LF** key together with the **RESET** key.

Keep pressing the **LF** key until the self test begins.

To run the LQ self test

Press both the **LF** and **ON LINE** keys simultaneously while turning ON the printer. If the printer is already turned ON, the LQ self test may be performed by pressing both the **LF** and **ON LINE** keys simultaneously together with the **RESET** key.

Keep pressing the **LF** and **ON LINE** keys until the self test begins.

To stop the self test temporarily

Press the **ON LINE** key to stop printing.

To resume the self test

Press the **ON LINE** key again to restart printing.

To terminate this function

Press the **RESET** key or turn off the power.

Note

Before initiating the self test, make sure that the width of the paper, especially fanfold paper loaded in the printer corresponds to the setting selected in the extended setup options.

44 PAPER WIDTH

Maximum printable columns at 10cpi

WIDTH: 15 IN	136 columns
WIDTH: 10 IN	80 columns
WIDTH: 5 IN	36 columns

Power-on operation summary

Operation (reference page)	LF	FF	ON LINE	PARK	QUALITY	M. LF	M. RLF	RLF	TEAR OFF	SETUP	ALT	RESET	POWER
Self test, draft (P21)	○											○	●
Self test,LQ (P21)	○		○									○	●
Hex dump, draft (P62)		○										○	●
Hex dump,LQ (P62)		○	○									○	●
Extended setup options (P33)										○		○	●
Demo printout (P22)							○	○				○	●
Loading MEMO 1 (P31)				○								○	●
Loading MEMO 2 (P31)					○							○	●
Loading MEMO 3 (P31)						○						○	●
Vertical alignment (P66)										○	○	○	●
EEPROM initialize 1	○			○	○		○						●
EEPROM initialize 2	○			○	○	○							●

Notes

1. Use either the **RESET** key or power switch when the circle is in both the RESET and POWER columns.
2. EEPROM initialize 2 operation requires the vertical alignment operation after the execution of the EEPROM initialize 2.

4. Basic setup options

About basic setup options

The setup options serve to define various initial states of the printer that are executed when the power is turned on or when the **RESET** key is pressed. In addition, this mode serves to redefine the font type, character spacing, and other parameters for the printer's current operating conditions. The parameters set in the setup options are stored in the memory of the printer and used as the default values in initialize operations.

□ To set this option

When the **SETUP** key is pressed in the offline mode, the printer enters the function setup option, where various functions can be set. The keys used in the function setup mode are described below.

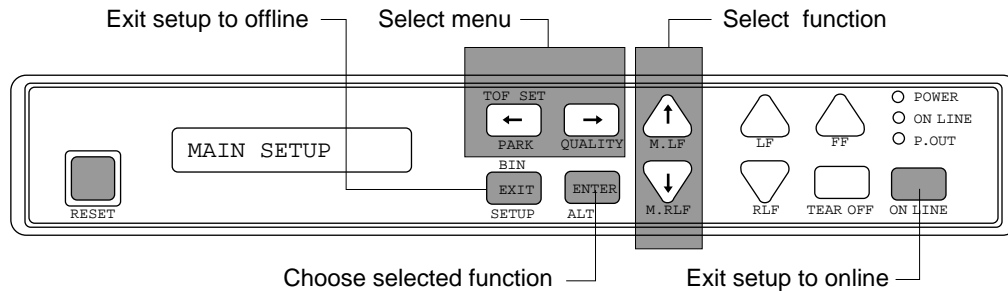

← and →	[Alternate to the PARK and QUALITY] These keys are used to go over menus in the display, but cannot be used to select a menu item.
↓ and ↑	[Alternate to the M.LF/M.RLF] These keys are used to go over items within a menu in the display, but cannot be used to set an item parameter.
ENTER	[Alternate to the ALT] When this key is pressed, an asterisk (*) indicating that the item is the currently selected parameter is added at the end of the item.
EXIT	[Alternate to the SETUP] When this key is pressed, the content of the item is stored in the memory of the printer. Then, the printer exits from the setup options and enters the offline mode.
ONLINE	This key's function is similar to the EXIT key in that the printer saves the selected item and exits from the setup options. At that time, if no errors or irregular conditions exist, the printer enters the online mode.

□ Selection procedure example

The following example illustrates the correct procedure to select a letter-portrait paper size from the front panel:

1. Press the **ON LINE** key to enter the offline state. The ON LINE LED is put out:
2. Press the **SETUP** key to enter the SETUP options. The LCD displays:

```
1  MULTIPART
```

3. Press the Right Arrow (→) key to select the menu and to display:

```
3  PAGE SINGLE
```

4. Press the Down Arrow (↓) key to step down the function items, and to display:

```
SIZE:  LETTERp
```

5. Press the **ENTER** key to select letter-size portrait as the desired PAPER SIZE. The LCD briefly displays the paper size with an asterisk at the end.

```
SIZE:  LETTERp*
```

6. Press the **EXIT** key to store the selection, terminate the setup options, and return to the offline state or press the **ON LINE** key to return to the on line state.

□ Setup Memory

Current memory

The printer contains one current memory for automatically storing the preset setup states and three user memories for storing data that is designated by the user.

The current memory automatically stores the configuration when the setup options are terminated. When the power is turned on or when the **RESET** key is pressed, the printer automatically sets the configuration per the current memory. Thus, when entering the setup options, the contents of the current memory can be altered.

User memory

The user memories can store three different configurations. The user can set and recall the contents of the memory to configure the printer. When the power is turned on or when the **RESET** key is pressed, the contents stored in the user memories are not used as the initial values. To use the contents of the user memories as the initial values, it is necessary to select one of the user memories, MEMO 1 to MEMO 3, in the setup options and evoke the contents as the preset condition.

To use the contents of the user memory as the current setup, it is necessary to display the “8 SELECT SETUP” on the menu and select one of the user memories. Exiting from the setup options with a user memory selected will cause the contents of the user memory to be stored in the current memory which then becomes the printer initial values.

To store a configuration in a user memory, display the “86 SAVE SETUP” selection in the extended setup options and select one of the user memories. The current setup content is stored in the specified memory when exiting the setup options.

Printing multipart paper

The multipart mode increases the print intensity on multipart forms.

1	MULTIPART
---	-----------

The followings will give an idea for proper selection:

COPY:	NORMAL	Original + 5 copies
COPY:	DARK 1	Original + 7 copies
COPY:	DARK 2	Original + 8 copies

Selecting page length for fanfold paper

The page length selection varies from 2 inches to 16.5 inches with a 0.5 inch increment. The page length is the same as the distance between two perforations.

The page length can be changed by software commands, but when the "Page Lock" option in the extended setup options is set enabled, this page length selection becomes the fixed length and software commands are ignored.

2	PAGE FANFOLD
---	--------------

PAGE:	2 IN
PAGE:	...
PAGE:	11 IN
PAGE:	...
PAGE:	16.5 IN

Default page length is 11 inches

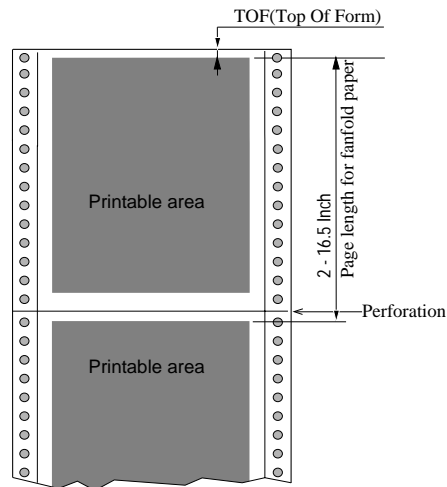

Selecting single sheet paper size

This function sets a paper size (page length, the right and left margins) of single sheet paper. The "Page Lock" option in the extended options can lock-in the character spacing selected in this option and ignores the related software command.

3 PAGE SINGLE

SIZE:	B5	p
SIZE:	B5	l
SIZE:	A4	p
SIZE:	A4	l
SIZE:	B4	p
SIZE:	B4	l
SIZE:	LETTER	p
SIZE:	LETTER	l
SIZE:	LEGAL	p
SIZE:	LEGAL	l
SIZE:	A3	p
SIZE:	A3	l

..... "P" denotes portrait.
 "I" denotes landscape
 Default page size is A4 portrait.

Note
A3 landscape can not be used with CSF.

item Paper Size	Left Margin (chr.)	Right Margin (chr.)	Recommended Number of Columns (chr./line)	Recommended printing area (length in mm)	Maximum length of page (mm)	Number of Lines / Page							
						EPSON/IBM				HP			
						Override OFF		Override ON		Override OFF		Override ON	
						TOF Adj.		TOF Adj.		TOF Adj.		TOF Adj.	
	0/60"	14/60"	0/60"	14/60"	0/60"	14/60"	0/60"	14/60"	0/60"	14/60"			
B5 Portrait	1	68	68	238	257	56	55	58	56	56	55	60	59
B5 Landscape	1	98	98	163	182	38	37	40	39	38	37	43	41
A4 Portrait	1	80	80	278	297	65	64	67	66	65	64	70	69
A4 Landscape	1	114	114	191	210	45	43	47	45	45	43	49	48
B4 Portrait	1	98	98	345	364	81	80	83	82	81	80	86	84
B4 Landscape	1	136	136	238	257	56	55	58	56	56	55	60	59
Letter Portrait	1	82	82	261	11"	61	60	63	62	61	60	66	64
Letter Landscape	1	108	108	197	8.5"	46	45	48	47	46	45	51	49
Legal Portrait	1	82	82	337	14"	79	78	81	80	79	78	84	82
Legal Landscape	1	136	136	197	8.5"	46	45	48	47	46	45	51	49
A3 Portrait	1	114	114	401	420	94	93	96	95	94	93	99	98
A3 Landscape	1	136	136	278	297	65	64	67	66	65	64	70	69

CONDITIONS

- Character Pitch: 10 CPI
- Line Feed Pitch: 6 LPI
- Page Length(in Epson/IBM) : = Paper form length - 0mm (top margin) - 17mm (bottom margin) - 2mm (tolerance)
- Page Length and Number of Lines in HP depend on the TOF position and override function.
- Right and Left Margin: correspond to the scale on the paper bail. (The unit is the number of characters).

Selecting font style

This selection is effective only in the LQ or NLQ print mode. There are 10 resident fonts provided.

When the OCR-A or OCR-B font is selected, either 10 cpi or 12 cpi character spacing can be selected. The "Font Lock" option in the extended options can lock-in the font selected in this option and ignores the related software command.

4	FONT SELECT
---	-------------

FONT: ROMAN
FONT: S.SERIF
FONT: COURIER
FONT: PRESTIGE
FONT: SCRIPT
FONT: OCR-B
FONT: OCR-A
FONT: GOTHIC
FONT: ORATOR
FONT: ORATORS

..... Default font is Roman.

..... Sans Serif

Note:

1. If the current 'QUALITY' selection is SD, SSD, DRAFT, or HQDR, the font selection depends on the EMULATION currently selected:
 HP mode — FONT SELECT selection is accepted and QUALITY is automatically changed to LQ.
 EPSON or IBM mode — FONT SELECT selection will not take effect until QUALITY selection is changed to either NLQ or LQ.
2. If the current 'CHAR PITCH' is set to 15, 16, 17.1, 20, or 24 and OCR-A or OCR-B is selected, the ROMAN font will be automatically substituted.

FONT	PRINT SAMPLE
ROMAN	ABCDEFGHIJKLMNopqrstuvwxyz
SANS SERIF	ABCDEFGHIJKLMNopqrstuvwxyz
COURIER	ABCDEFGHIJKLMNopqrstuvwxyz
PRESTIGE	ABCDEFGHIJKLMNopqrstuvwxyz
SCRIPT	ABCDEFGHIJKLMNopqrstuvwxyz
OCR-B	ABCDEFGHIJKLMNopqrstuvwxyz
OCR-A	ABCDEFGHIJKLMNopqrstuvwxyz
GOthic	ABCDEFGHIJKLMNopqrstuvwxyz
ORATOR	ABCDEFGHIJKLMNopqrstuvwxyz
ORATOR-S	ABCDEFGHIJKLMNopqrstuvwxyz

Selecting character spacing

This function selects one of the fixed spaced characters and proportional spaced characters. The "Pitch Lock" option in the extended setup options can lock-in the character spacing selected in this option and ignores the related software command.

When SD (speed draft) or SSD (super speed draft) is set the character spacing automatically changes to 12 cpi or 15 cpi, respectively.

When OCR-A or OCR-B font is selected, either 10 cpi or 12 cpi can be selected.

5 CHAR PITCH

PITCH: 10 CPI
PITCH: 12 CPI
PITCH: 15 CPI
PITCH: 16.7 CPI
PITCH: 17 CPI
PITCH: 20 CPI
PITCH: 24 CPI
PITCH: PROP.
PITCH: 1/2PROP.

..... Default character spacing is 10 cpi printing

Letter Quality

Character pitch	Dot-spacing (V x H)	Character structure (V x H)
10 cpi	1/180 X 1/360	24 X 36
12 cpi	1/180 X 1/360	24 X 30
15 cpi (EPSON)	1/180 X 1/360	16 X 24
15 cpi (HP/IBM)	1/180 X 1/720	24 X 36(+12)
16.7 cpi	1/180 X 1/720	24 X 36(+7)
17 cpi	1/180 X 1/720	24 X 36(+6)
20 cpi	1/180 X 1/720	24 X 30(+6)
24 cpi (EPSON)	1/180 X 1/720	16 X 24(+6)
24 cpi (HP/IBM)	1/180 X 1/720	24 X 24(+6)
Proportional	1/180 X 1/360	24 X N
1/2 Proportional	1/180 X 1/720	24 X N

Character Pict	Print Sample
10 CPI	ABCDEFGHIJKLMNopqrstuvwxyz
12 CPI	ABCDEFGHIJKLMNopqrstuvwxyz
15 CPI (EPSON)	ABCDEFGHIJKLMNopqrstuvwxyz
15 CPI (HP/ IBM)	ABCDEFGHIJKLMNopqrstuvwxyz
16.7 CPI	ABCDEFGHIJKLMNopqrstuvwxyz
17.1 CPI	ABCDEFGHIJKLMNopqrstuvwxyz
20 CPI	ABCDEFGHIJKLMNopqrstuvwxyz
24 CPI(EPSON)	ABCDEFGHIJKLMNopqrstuvwxyz
24 CPI (HP/ IBM)	ABCDEFGHIJKLMNopqrstuvwxyz
Proportional	ABCDEFGHIJKLMNopqrstuvwxyz
1/2 Proportional	ABCDEFGHIJKLMNopqrstuvwxyz

The Proportional character width is twice the 1/2 Proportional width. In the Epson mode, the print quality is changed to the high quality one. In the IBM or HP mode, print quality does not change the print quality.

Enlarging/compressing print

Enlarges or compresses the text size.

Any setting other than 100% will cancel the double height printing mode. The relationships between the paper sizes with their enlargement and compressing ratio are described below.

Note: Enlarge ratio of 200% or less is recommended to prevent single sheets from paper skew.

6	ZOOM IN/OUT
---	-------------

ZOOM OUT:	66 %
ZOOM OUT:	79 %
ZOOM OUT:	83 %
ZOOM OUT:	91 %
NO ZOOM:	100 %
ZOOM IN:	116 %
ZOOM IN:	120 %
ZOOM IN:	141 %
ZOOM IN:	200 %
ZOOM IN:	400 %
ZOOM IN:	600 %
ZOOM IN:	800 %
ZOOM IN:	1000 %
ZOOM IN:	1200 %
ZOOM IN:	1400 %
ZOOM IN:	1600 %

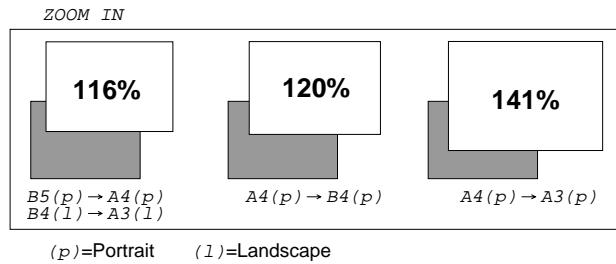
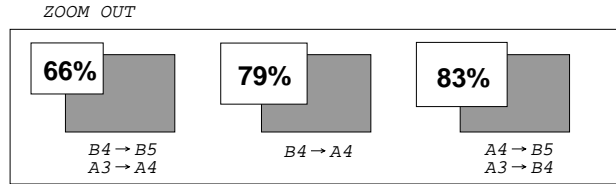

66%
79%
83%
91%
100% ——— 4 point character size
116%
120%
141%
200%

400%
600%
800%
1000%
1200%
1400%
1600%

Note: This sample illustrates only a scale image.

Setting top of form position

The top-of-form (TOF) can be set using this function, anywhere from a minimum of 0 inch to a maximum of 480/60 inches (8 inches = 203mm) by increments of 1/60 inch.

Press the Up or Down arrow keys to increase or decrease the TOF setting, respectively. Press the **ENTER** key to select the desired setting.

7	TOF ADJUST
---	------------

TOF:	+	0/60IN
TOF:	+	nnn/60IN
TOF:	+	480/60IN

..... Defaults to 14/60 inch

Note: Any improper setting of TOF position will set it back to the default value. The top of form differs from the top margin in that the top of form determines the first line of the print station where the top margin can be moved anywhere between the top of the form and the bottom margin. See "40 TOP MARGIN" on page 47.

Note

When using settings less than 14/60", the printer is more susceptible to a paper jam, depending on forms type being used.

Loading user & factory setup options

Loads one of three user designed setup options to the current active memory. This will erase and replace setup contents in the current memory. The printer has three setup storage areas that can store different setups. If you need to save the current setups before replacement, it is necessary to select the "86 SAVE SETUP" item in the extended setup options on page 56.

8	SELECT SETUP
---	--------------

SETUP:	MEMO 1
SETUP:	MEMO 2
SETUP:	MEMO 3
SET.:	FACTORY

Equivalent short cut operation can be performed when:
 pressing the **PARK** key with the **RESET** key,
 pressing the **QUALITY** key with the **RESET** key,
 pressing the **M.LF** key with the **RESET** key.

Note: When this setting is executed, the printer will be initialized.

Factory Default Setting

Option Menu	Factory Default	Option Menu	Factory Default
<Basic options>			
1 MULTIPART	NORMAL	38 PCL MODE	PCL3+
2 PAGE FANFOLD	11"	39 CHR TB2 HP	LINE-DRAW
3 PAGE SINGLE	A4 PORTRAIT	40 TOP MARGIN	0 LINE
4 FONT SELECT	ROMAN	41 BOTTOM MARGIN	0 LINE
5 CHAR PITCH	10 CPI	42 LEFT M.	0 COLUMN
6 ZOOM IN/OUT	100%	43 RIGHT M.	0 COLUMN
7 TOF ADJUST	14/60 INCH	44 PAPER WIDTH	15 INCH
		45 AUTO SCROLL	NO SCROLL
<Extended options>		46 OVERRIDE BM	YES
10 EMULATION	EPSON	47 LABEL MODE	NO
11 CHR TB HP	ROMAN-8	48 P.OUT DTCT	ANY POS
12 CHR TB EPSON	ITALIC	49 CSF OPTION	NOT INSTALLED
13 CHR TB IBM	SET 1	50 SCROLL POS	ANY POS
14 NATIONAL FONT	USA	51 LF SPEED	NORMAL
15 CODE PAGE	437(USA)	60 INTERFACE	PARALLEL
16 AGM IBM	NO	61 SLCT IN CMD	NO
17 CR SETTING	CR ONLY	62 PARITY BIT	NON
18 LF SETTING	LF+CR	63 DATA LENGTH	8 BITS
19 LF PITCH	6 LPI	64 STOP BIT	1 BIT
20 ZERO STYLE	NO-SLASHED	65 PROTOCOL	DTR
21 TABULATION	8 CHAR.	66 BAUD RT	9600 BPS
22 PAGE LOCK	NO	67 SERIAL ERROR	PRINT *
23 QUALITY	LQ	68 CTS ENABLE	NO
24 FONT LOCK	NO	69 CD ENABLE	NO
25 PITCH LOCK	NO	70 DSR ENABLE	NO
26 QLTY LOCK	NO	71 BUFFER SIZE	64 KB
27 BC/L.CHR	MODE 1	72 BUSY/ACK	TYPE 2
28 BC TYPE	CODE39	73 DATA LATCH	TYPE F
29 BC SIZE	1	74 ERROR STATUS	YES
30 LARGE CH.SIZE	8	80 PRINT DIR	BI-DIRECTION
31 GR QLTY	MODE 2	81 DISPLAY LANG	ENGLISH
32 ACCENT CHR	SIMPLE	82 INVERT DISP	NO
33 FF CODE/TOF	YES	83 SOFTWARE SET	YES
		84 RESET LOCK	NO
		85 SLEEP MODE	YES

Option Menu	CURRENT	MEMO1	MEMO2	MEMO3
<Basic options>				
4 FONT SELECT	ROMAN	COURIER	COURIER	COURIER
<Extended options>				
10 EMULATION	EPSON	HP	HP	IBM
18 LF SETTING	LF+CR	LF ONLY	LF ONLY	LF ONLY
32 ACCENT CHR.	SIMPLE	COMPO.	COMPO.	SIMPLE
38 PCL MODE	PCL3+	PCL3+	PCL3	PCL3+
61 SLCT IN ENBL	NO	NO	NO	YES

5. Extended setup options

About extended setup options

The extended setup options contain various setup options which are used less frequently than the basic setup options. The function in these options are categorized to four functional blocks:

- items numbering in 10's through 30's are for "Print enhancement" which defines the emulation type or character tables;
- items numbering in 40's and 50's are for "Paper handling enhancement" which defines the paper characteristics or print area;
- items numbering in 60's and 70's are for "Communication enhancement" which defines the interface control parameters; and
- items numbering in 80's are for other functional items to "Miscellaneous".

For the overview of the extended setup options, refer to the extended setup options summary on page 34 and 35.

Note: You may have noticed that some option numbers are skipped in the display. Those skipped item numbers are reserved for special use and they do not affect regular operation of this printer.

❑ To set this option

By pressing and holding the **SETUP** key when the **RESET** key is pressed, the printer enters the extended setup options, where various functions including the basic setup options can be set. The keys and operation method in the extended setup options are the same as those in the basic setup options. However, when exiting from the extended setup options, the initialization of the printer will be conducted by printing the **RESET** key.

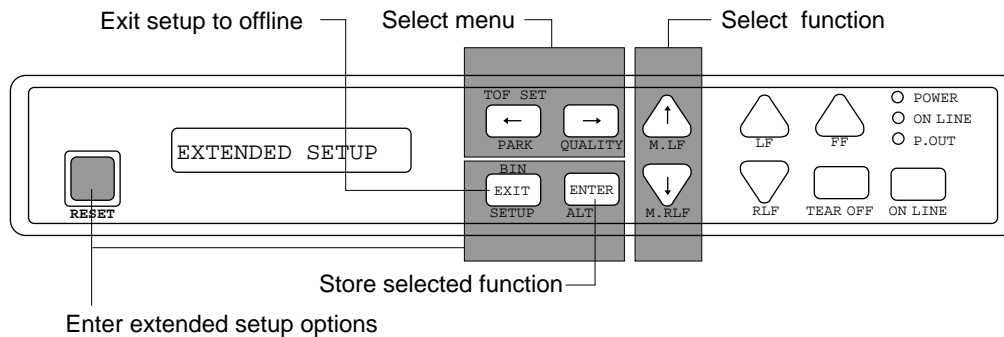

Extended setup options summary

Press both the **SETUP** and **RESET** keys to enter the extended setup options.

●Basic setup options #1-#8 ●Extended setup options #1-#87

1 MULTIPART

- NORMAL *
- DARK 1
- DARK 2

2 PAGE LENGTH (FANFOLD)

- 2
- 2.5
- 3
- 3.5
- 4
- 4.5
- 5
- 5.5
- 6
- 6.5
- 7
- 7.5
- 8
- 8.5
- 9
- 9.5

3 PAGE LENGTH (SINGLE)

- B5 PORT
- B5 LAND
- A4 PORT *
- A4 LAND
- B4 PORT
- B4 LAND
- LETTER PORT
- LETTER LAND
- LEGAL PORT
- LEGAL LAND
- A3 PORT
- A3 LAND

4 FONT SELECT

- ROMAN *
- SANS SERIF
- COURIER
- PRESTIGE
- SCRIPT
- OCR-B
- OCR-A
- GOTHIC
- ORATOR
- ORATOR-S

5 CHARACTER PITCH

- 10 CPI *
- 12 CPI
- 15 CPI
- 16.7CPI
- 17.1CPI
- 20 CPI
- 24 CPI
- PROPORTIONAL
- 1/2 PROPORTIONAL

6 ZOOM IN/OUT

- 66 %
- 79 %
- 83 %
- 91 %
- 100 % *
- 116 %
- 120 %
- 141 %
- 200 %
- 400 %
- 600 %
- 800 %
- 1000 %
- 1200 %
- 1400 %
- 1600 %

The asterisk (*) indicates the factory default setting.

7 TOF ADJUSTMENT

TOP OF FORM + n/60 inches

0 ≤ n ≤ 480

Default: n=14

8 SELECT SETUP MEMORY

- MEMO 1
- MEMO 2
- MEMO 3
- FACTORY

10 EMULATION

EMULATION MODE

- EPSON *
- IBM
- HP

11 CHARACTER TABLE (HP)

EMULATION MODE

- ROMAN-8 *
- CODE PG
- PC-8D/N
- ECMA
- LEGAL

- SWEDEN1
- SWEDEN2
- SPAIN
- FRANCE
- GERMAN
- U.K.
- PORTUGAL
- NORWAY1
- NORWAY2

- IRV
- ITALY
- FRAN2
- GERMAN2
- SPAIN2
- SPAIN3
- JAPAN
- PORTUGAL2

12 CHARACTER TABLE (EPSON)

- CHARA. TABLE
- ITALIC *
- GRAPHICS
- DOWNLOAD
- CODE PAGE

13 CHARACTER TABLE (IBM)

- CHARA. TABLE
- CHAR.SET1 *
- CHAR.SET2

14 NATIONAL FONT

- USA *
- FRANCE
- GERMANY
- U.K.
- DENMARK
- SWEDEN
- ITALY

- SPAIN
- JAPAN
- NORWAY
- DENMARK2
- SPAIN 2
- LATIN AMERICA
- KOREA
- TURKEY
- LEGAL

15 CODE PAGE

CODE PAGE

- 437:USA *
- 850:MULTILINGUAL
- 857:TURKEY
- 858
- 860:PORTUGAL
- 861

16 AGM (IBM)

ALTERNATE GRAPHIC

- NO *
- YES
- 863:CANADIAN-FRENCH
- 865:NORWAY
- BRASCI
- ABICOMP
- ISO-8859-1

17 CR SETTING

CR SETTING

- CR ONLY *
- CR+LF
- AUTOFEED

18 LF SETTING

LF SETTING

- LF ONLY
- LF+CR *

19 LF PITCH

PITCH

- 6 LPI *
- 8 LPI
- 9 LPI
- 3 LPI
- 4 LPI

20 ZERO STYLE

ZERO STYLE

- NO-SLASHED *
- SLASHED

21 TABULATION

TABULATION

- 2 CHAR.
- 4 CHAR.
- 6 CHAR.
- 8 CHAR. *
- 10 CHAR.
- 12 CHAR.

22 PAGE LENGTH LOCK

PAGE LOCK

- NO *
- YES

23 QUALITY

QUALITY TYPE

- LQ *
- NLQ
- HQDR

24 FONT LOCK

FONT LOCK

- NO *
- YES

25 PITCH LOCK

PITCH LOCK

- NO *
- YES

26 QUALITY LOCK

QUALITY LOCK

- NO *
- YES

27 BARCODE/ENLARGED CHARACTER

BC/L. CHR

- IGNORED
- MODE1 *
- MODE2

28 BARCODE TYPE

BARCODE TYPE

- INDUSTRIAL 20F5
- INTERLEAVED 20F5
- MATRIX 20F5
- CODABAR
- CODE11
- CODE39*
- CODE93
- CODE128
- EAN8

29 BARCODE SIZE

- 1*
- 1.5
- 2
- 2.5

30 ENLARGED CHAR SIZE

- 1
- 2
- 4
- 8*
- 12
- 16
- 24
- 32

31 GRAPHIC PRINT MODE

PRINT SPEED

- MODE1
- MODE2*
- MODE3

32 ACCENT CHAR

PRINT METHOD

- SIMPLE*
- COMPO

Next page

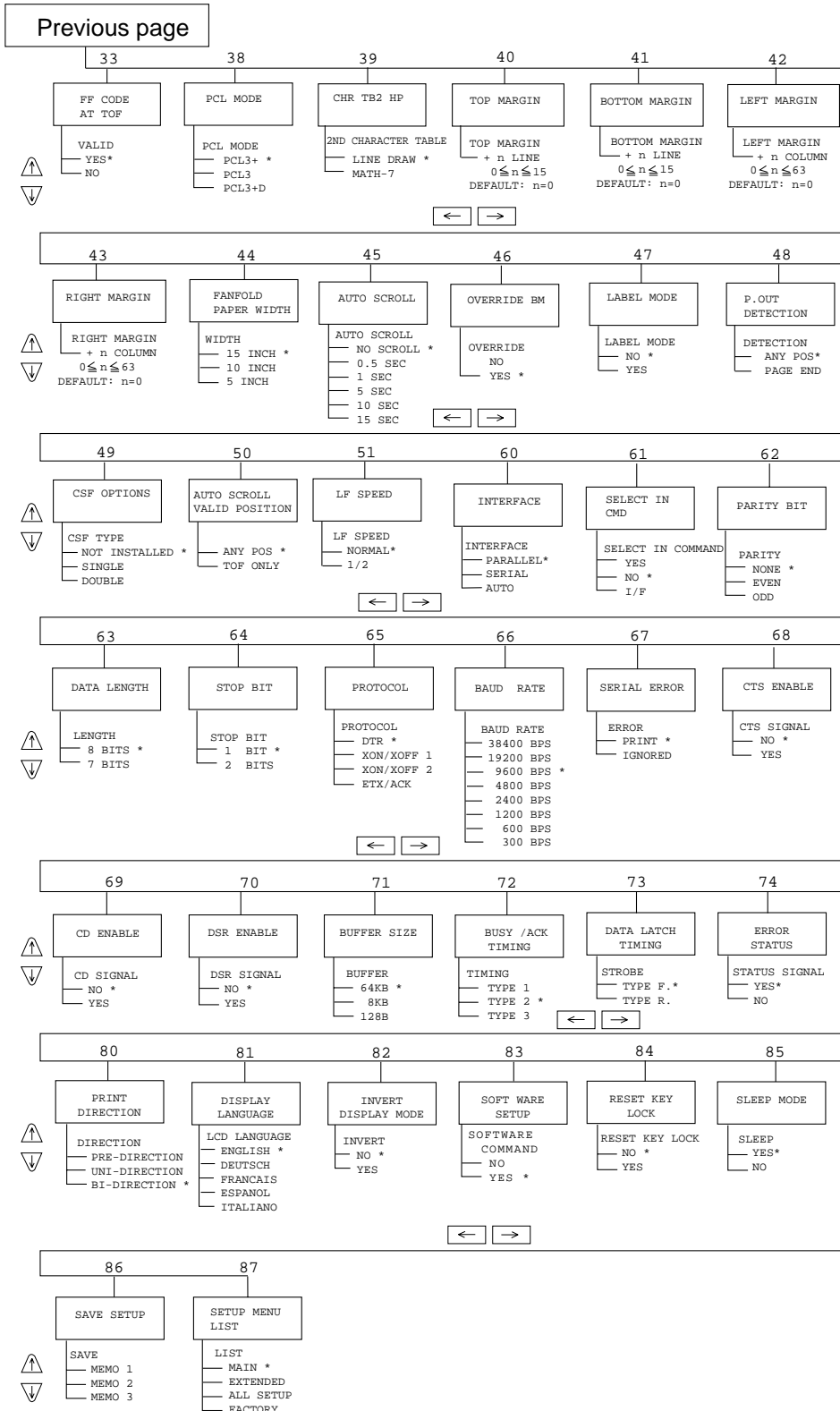

Print enhancement

Emulation

The desired emulation mode of the printer can be selected using this function.

10 EMULATION

EML: EPSON Epson LQ-2550 compatible
EML: IBM IBM 2391 compatible
EML: HP RuggedWriter 480 compatible

Character table (HP mode)

This function selects one of character sets provided in the HP emulation.

11 CHR TB HP	PCL3, PCL3+, PCL3+D mode	
TBL: ROMAN-8	ROMAN-8 (8U)	
TBL: CODE PG	CODE PAGE	Setup menu #15 CODE PAGE:
TBL: PC-8D/N	PC-8 (11U)	CODE PAGE 437 PC-8(10U)
TBL: ECMA	(ISO 8859-1,0N)	CODE PAGE 850 PC-850(12U)
TBL: LEGAL	(HP SET,1U)	CODE PAGE 857 TURKEY
TBL: SWEDEN1	(ISO-10,0S)	CODE PAGE 858 EURO SYMBOL
TBL: SWEDEN2	(ISO-11,3S)	CODE PAGE 860 PORTUGAL
TBL: SPAIN1	(ISO-17,2S)	CODE PAGE 861 ICELANDIC
TBL: FRANC1	(ISO-69,1F)	CODE PAGE 863 CANADIAN-FRENCH
TBL: GERMAN	(ISO-21,1G)	CODE PAGE 865 NORDIC
TBL: U.K.	(ISO-4,1E)	CODE PAGE BRASCII
TBL: PORTU1	(ISO-16,4S)	CODE PAGE ABICOMP
TBL: NORWAY1	(ISO-60,0D)	ISO-8859-1
TBL: NORWAY2	(ISO-61,1D)	
TBL: IRV	(ISO-2,2U)	
TBL: ITALY	(ISO-15,0I)	
TBL: FRANC2	(ISO-25,0F)	
TBL: GERMN2	(HP SET,0G)	
TBL: SPAIN2	(HP SET,1S)	
TBL: SPAIN3	(ISO-85,6S)	
TBL: JAPAN	(ISO-14,0K)	
TBL: PORTU2	(ISO-84,5S)	

See page 38

Character table (Epson mode)

This function selects one of character sets provided in the Epson emulation.

12 CHR TB EPSON

TBL: ITALIC	Sets italic table (see page 127)
TBL: GRAPHIC	Sets graphic table (see page 127)
TBL: DOWN LD	Sets user defined download table
TBL: CODE PG	This selection replaces the ASCII character area 80h-FFh with the code page selected in "15 CODE PAGE"

Character table (IBM mode)

This function selects between the IBM character set 1 and set 2.

Refer to the character set tables in Appendix C.

13 CHR TB IBM

TBL: SET 1	Sets IBM character set 1 table (see page 128)
TBL: SET 2	Sets IBM character set 2 table (see page 129)

National font style

One of the following 16 national fonts can be selected.

14 NATIONAL FONT		ASCII HEXADECIMAL											
		23	24	40	5B	5C	5D	5E	60	7B	7C	7D	7E
CNTRY :	USA	#	\$	@	[\]	^	'	{		}	~
CNTRY :	FRANCE	#	\$	à	°	ç	§	^	'	é	ù	è	..
CNTRY :	GERMANY	#	\$	§	Ä	Ö	Ü	^	'	ä	ö	ü	ß
CNTRY :	U.K.	£	\$	@	[\]	^	'	{		}	~
CNTRY :	DENMRK	#	\$	@	Æ	Ø	Å	^	'	æ	ø	å	~
CNTRY :	SWEDEN	#	¤	É	Ä	Ö	Å	Ü	é	ä	ö	å	ü
CNTRY :	ITALY	#	\$	@	°	\	é	^	ù	à	ò	è	ì
CNTRY :	SPAIN	₧	\$	@	ı	Ñ	¿	^	'	..	ñ	}	~
CNTRY :	JAPAN	#	\$	@	[¥]	^	'	{		}	~
CNTRY :	NORWAY	#	¤	É	Æ	Ø	Å	Ü	é	æ	ø	å	ü
CNTRY :	DNMRK 2	#	\$	É	Æ	Ø	Å	Ü	é	æ	ø	å	ü
CNTRY :	SPAIN 2	#	\$	á	ı	Ñ	¿	é	'	í	ñ	ó	ú
CNTRY :	LATN AM	#	\$	á	ı	Ñ	¿	é	Ü	í	ñ	ó	ú
CNTRY :	KOREA	#	\$	@	[₩]	^	'	{		}	~
CNTRY :	TURKEY	#	ı	İ	Ç	Ö	Ş	Ü	ğ	ç	ö	ş	ü
CNTRY :	LEGAL	#	\$	§	°	'	"	¶	'	©	®	†	™

Code page

The default code page can be selected using this function. Refer to the code page table in Appendix C.

15 CODE PAGE		
C.P. :	437 USA (see page 133)
C.P. :	850 Multilingual (see page 133)
C.P. :	857 Turkey (see page 133)
C.P. :	858 Multilingual Euro symbol(see page 134)
C.P. :	860 Portugal (see page 134)
C.P. :	861 Icelandic (see page 134)
C.P. :	863 Canadian-French (see page 134)
C.P. :	865 Norway (see page 135)
C.P. :	BRASCII BRASCII (see page 135)
C.P. :	ABICOMP ABICOMP (see page 135)
C.T. :	ISO-1 ISO-8859-1(see page 135)

IBM Alternate graphic mode (AGM) (Valid in IBM mode)

This function enables the IBM emulation to work similar to the Epson emulation in high density graphics. The table below describes the differences in their related control codes.

16 AGM IBM

AGM:	NO
AGM:	YES

Command	AGM: NO	AGM: YES
ESC 3 n	Set n/216" line spacing	Set n/180" line spacing
ESC J n	Line feed n/216"	Line feed n/180"
ESC A n	Set n/72" line spacing	Set n/60" line spacing
ESC *	Not supported	Set various graphic modes

Carriage return (CR)

A carriage return (ASCII code 0Dh or 13) causes data in the buffer to be printed and the carriage to be moved to the left most print position at the same line. The following option can be selected when issuing a carriage return. Refer to the specification of your application for correct selection.

17 CR SETTING

CR:	CR ONLY	Carriage return without a line feed
CR:	CR+LF	Carriage return with a line feed
CR:	AT FEED	Autofeed signal enabled

Note: Autofeed is effective for the system using parallel interface with AUTO FEED signal to control the the carriage return with or without a line feed. The autofeed signal must be low when the printer is initialized in order to add a line feed to every CR code.

Line feed (LF)

This function selects whether to execute the carriage return operation when receiving the line feed command (LF code).

18 LF SETTING

LF:	LF ONLY	Line feed without a carriage return
LF:	LF+CR	Line feed with a carriage return

Line feed spacing

This function selects the default line feed spacing. When no line feed spacing is set in the software command, this value is used as a linefeed.

19 LF PITCH

LF:	6 LPI
LF:	8 LPI
LF:	9 LPI
LF:	3 LPI
LF:	4 LPI

Slashed zero

The zero style is selected as either “0” (no-slash) or “Ø” (slashed).

20 ZERO STYLE

ZERO:	NO-SLSH	“0” (no-slash) is selected
ZERO:	SLASHED	“Ø” (slashed) is selected

Set default tab stops

The default horizontal tab stops are selected from different tab intervals. This tab setting becomes effective when the printer receives tab commands from the host system.

21 TABULATION

TAB:	2 CHAR
TAB:	4 CHAR
TAB:	6 CHAR
TAB:	8 CHAR
TAB:	10 CHAR
TAB:	12 CHAR

Lock-in the page length

The page length and the top and bottom margins set on the front control panel are locked-in. Any page layout related software command cannot override this setting.

22 PAGE LOCK

LOCK:	YES
LOCK:	NO

Print quality

The letter or draft quality printing or their variations can be selected. This function performs the same way as when the QUALITY key is pressed on the front control panel. This function selects the graphic print speed. See the page 19.

23 QUALITY

QLTY: LQ Letter quality printing
QLTY: NLQ Near letter quality printing
QLTY: HQDR High quality draft printing
QLTY: DRAFT	
QLTY: S.D Speed draft printing (12cpi)
QLTY: S.S.D Super speed draft printing (15cpi)

Lock-in the font

The character font set in the "Selecting font style" option on page 28 are locked-in, so any character font related software command cannot override this setting.

24 FONT LOCK

LOCK: YES
LOCK: NO

Lock-in the character spacing

The character spacing set the "Selecting character spacing" option on page 29 are locked-in, so any character spacing related software command cannot override this setting.

25 PITCH LOCK

LOCK: YES
LOCK: NO

Lock-in the print quality

The print quality set the "print quality" option on page 41 are locked-in, so any print quality related software command cannot override this setting.

26 QLTY LOCK

LOCK: YES
LOCK: NO

Bar code print enhancement

Enable Bar code print and Enlarged character

This function enables the printer to accept the control commands of the barcode and enlarged character.

27 BC/L. CHR

BC: MODE 1 ESC SO and ESC SI can not be used for the bar code data start or stop command.
BC: MODE 2 ALL control command are valid.
BC: IGNORED Bar code and Enlarged character are invalid.

Bar code type

This function selects a type of bar code. Bar code type **element** enables you to print bar codes by varying the width of the narrow bar, wide bar, narrow space, wide bar, or intercharacter gap. See Appendix B, "**Bar code control code**" for details.

28 BC TYPE

TYPE: INDST25
TYPE: INTRL25
TYPE: MATRIX
TYPE: CODABA
TYPE: CODE11
TYPE: CODE39
TYPE: CODE93
TYPE: C128
TYPE: EAN-8
TYPE: EAN-13
TYPE: UPC-A
TYPE: UPC-E
TYPE: POSTNET
TYPE: ELEMENT

Industrial 2 of 5



Interleaved 2 of 5



Matrix 2 of 5



Codabar



CODE 11



CODE 39



CODE 93



CODE 128



EAN-8



EAN-13



UPC-A



UPC-E



POSTNET



Bar code specifications

The table below shows the specifications of thirteen types of bar codes available for the printer. Bar code printing examples are shown on the previous page.

Bar code	Structure	ICG	letters (#)	Check character	Sample data	Remark
Industrial 2/5	5B4S	Yes	0-9	Yes (Mod 10)	1234567	
Interleaved 2/5	5B5S (2 characters as one unit)	No	0-9	Yes (Mod 10)	1234567	Even number, including check character. Data length is variable.
Codabar	4B3S	Yes	0-9, Special characters: 24	Yes (Mod 16)	1234567	Start and end codes are sent by the user.
Matrix 2/5	3B2S	Yes	0-9	Yes (Mod 10)	1234567	
Code 11	3B2S	Yes	0-9, "-"	Yes (Mod 11)	1234567	Start and end codes are (△) code. Dual check character
Code 39	5B4S	Yes	0-9, AB,...(43)	Yes (Mod 43)	1234567	Start and end codes are asterisk (*) codes.
Code 93	3B3S	No	ASCII (128)	Yes (Mod 47)	1234567	Two check characters
Code 128	3B3S	No	ASCII (128)	Yes (Mod 103)	1234567	
EAN-8	2B2S	No	0-9	Yes (Mod 10)	4912345	8 digits (2 prefix code +5 data code+Check character)
EAN-13	2B2S	No	0-9	Yes (Mod 10)	491234567890	13 digits (2 prefix code +10 data code+Check character)
UPC-A	2B2S	No	0-9	Yes (Mod 10)	01234500006	12 digits (NSC+10 data+ Check character)
UPC-E	2B2S	No	0-9	Yes (Mod 10)	01234500006	UPC-A (12-digit) data is automatically converted into UPC-E (10-digit) data.
Postnet	2LB3SB	No	0-9	Yes (Mod 10)	123456789	6, 10 or 12 digits (data +Check character)

"B" and "S" in the "Structure" column show the number of bars and spaces which consist of one or two characters. LB and SB mean long bar and shot bar, respectively.

Bar code size

This function specifies the default bar code size.

29 BC SIZE
BC SIZE: 1
BC SIZE: 1.5
BC SIZE: 2
BC SIZE: 2.5

The tables below show bar code sizes and attributes.

SIZE	1	1.5	2	2.5
NARROW BAR	2/120inch	3/120inch	4/120inch	5/120inch
WIDE BAR	6/120inch	9/120inch	12/120inch	15/120inch
NARROW SPACE	2/120inch	3/120inch	4/120inch	5/120inch
WIDE SPACE	6/120inch	9/120inch	12/120inch	15/120inch
INTER CHARA.GAP	2/120inch	3/120inch	4/120inch	5/120inch
BAR HEIGHT	8/12inch	8/12inch	12/12inch	12/12inch

HRI PRINT	BELOW
HRI FONT	OCR-B
CHECK CHARACTERS	Added
PRINT DENSITY	1/120 inch

Enlarged character size

This function specifies the default size of enlarged characters.

30 LARGE CH.SIZE
SIZE : 1
SIZE : 2
SIZE : 4
SIZE : 8
SIZE : 12
SIZE : 16
SIZE : 24
SIZE : 32

Graphic Print Speed

This function selects the print speed of the 120 DPI/240DPI and 180 DPI/360DPI graphics.

31 GR QLT

QLTY: MODE1
QLTY: MODE2
QLTY: MODE3

	120/240DPI		180/360DPI	
	SPEED	Min.Dot pitch	SPEED	Min.Dot pitch
MODE1	15.7IPS	1/120"	10.5IPS	1/180"
MODE2	18.0IPS	1/120"	18.0IPS	1/120"
MODE3	31.5IPS	1/60"	24IPS	1/60"

Accent character

This function specifies the method of printing accent characters.

32 ACCENT CHR.

PRINT:SIMPLE
PRINT:COMPO

..... The accent character of the resident font is printed.
 The accent symbol and the character are printed
 separately to add the accent symbol in the proper position.

Setting of the FF (Form Feed) code at TOF

33 FF CODE / TOF

FF CODE/TOF:YES
FF CODE/TOF:NO

Establish the setting whether or not FF(Form Feed) is to be executed.

When "YES" is set, the FF code performs Form Feed even if the present position is at TOF.

When "NO" is set, the FF code is ignored when the present position is at TOF.

HP mode enhancement PCL Mode (HP mode)

This function selects the emulation level in HP mode.

38 PCL MODE

MODE: PCL3+
MODE: PCL3
MODE: PCL3+D

PCL3 →	Fully compatible with the Rugged Writer 480. The character pitches(15, 17.1 and 24) and print quality modes (HQDR, NLQ, S.D., S.S.D.) cannot be selected by software commands.
PCL3+ →	Extra capability to the Rugged Writer 480. In this mode, additional character pitches, print quality modes, and raster graphics resolutions may be selected by software command.
PCL3+D →	Limited DESK-JET compatibility. In this mode, the commands "ESC * p # Y" and "ESC * p # X" define units in 1/360". If you want print DESK-JET application data, you can make use of PCL3+D. The print position and graphics of the PCL3+D are closer than the other two modes to the DESK JET.

Secondary character table (HP mode)

This function selects symbol set of the secondary font table.

39 CHR TB2 HP

TBL: LINE Line draw
TBL: MATH MATH-7

Paper handling enhancement

Set the top margin

This function sets the top margin by lines with fixed line spacing of 6 lines per inch in the range between 0 to 15 lines (2.5") from the top of the form.

40 TOP MARGIN	
T.M. :	0 LINE
T.M. :	nn LINE
T.M. :	15 LINE

Set the bottom margin

This function sets the bottom margin by lines with fixed line spacing of 6 lines per inch in the range between 0 to 15 lines (2.5") from the bottom edge of the form.

41 BOTTOM MARGIN	
B.M. :	0 LINE
B.M. :	nn LINE
B.M. :	15 LINE

Note

The bottom edge of the form is determined by the page length or the paper size set by the PAPER key in the front control panel or in the associated paper size options in the basic setup options. See the paper size table on page 27.

Set the left margin

This function sets the left margin by columns with fixed character spacing of 10 characters per inch in the range between 0 to 63 columns (6.3") from the left-most printable location.

42 LEFT M.	
L.M. :	0 COL
L.M. :	nn COL
L.M. :	63 COL

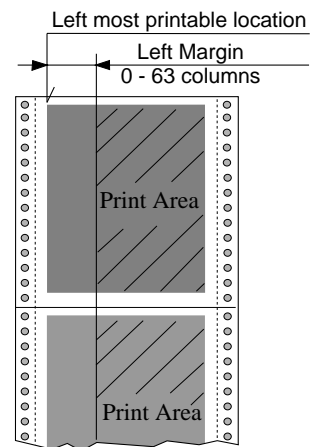
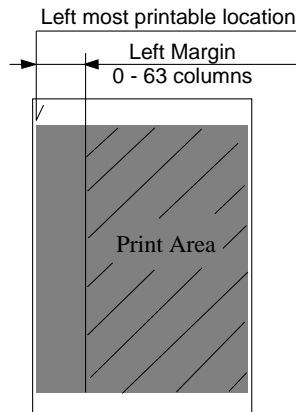

Set the right margin

This function sets the right margin by columns with fixed character spacing of 10 characters per inch in the range between 0 to 63 columns (6.3") from the right-most printable location.

43 RIGHT M.
R.M. : 0 COL
R.M. : nn COL
R.M. : 63 COL

Note
The right edge of the form is determined by the paper size set in the front control panel or the paper width set in the setup options on page 25 and 26.

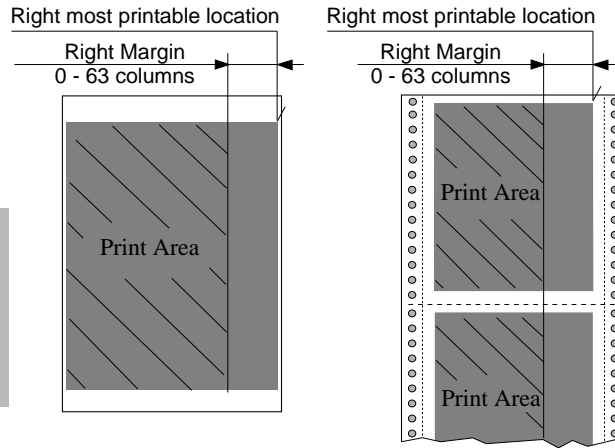

Fanfold paper width

This function sets the paper width to be used in the printer. Depending on the paper width, the print head will shift to the one half of the print width selected in this function to properly hold the paper in place, and eliminates the possibility of paper jams during loading.

44 PAPER WIDTH
WIDTH: 15 IN
WIDTH: 10 IN
WIDTH: 5 IN

Maximum printable column at 10 cpi

.....	136 columns
.....	80 columns
.....	36 columns

Autoscroll delay

The Autoscroll function automatically advances the paper to the tear off position when no data exists in the communication buffer and no new data is received for a period of 0.5, 1, 5, 10, or 15 seconds.

The printer automatically aligns the paper to the top of the next form when data is received. This feature is very beneficial when it is necessary to print a single invoice, and tear it off immediately following printing.

45 AUTO SCROLL
NO SCROLL
SCROLL: 0.5SEC
SCROLL: 1 SEC
SCROLL: 5 SEC
SCROLL: 10 SEC
SCROLL: 15 SEC

Note
Autoscroll becomes invalid when the label protect mode is set active.

Override bottom margin

The effect of this function varies depending whether you are using Cut Sheet or Fanfold paper. The operation of this function is also varied depending upon the Emulation setting (and if in HP emulation, the PCL mode setting).

46 OVERRIDE BM

OVERRIDE: NO

OVERRIDE: YES

When using Cut Sheet paper, the bottom margin is set 17 mm from the bottom of the page. The bottom margin setting can be overridden by this function, however, there may be some degradation of print registration in the override print area. Refer to the sketch and Table shown below for details of printable area and number of lines/page as affected by the setting of this function.

When using Fanfold paper, this function only affects the printer's operation on the last sheet of paper when a paper out condition occurs. When remove the fanfold paper from the tractors, printing will stop approximately 4 inches from the bottom edge of the paper. When a paper out condition occurs you may either move the Friction Lever to the Cut Sheet position and remove the form from the tractors, or you may place the printer back Online and continue printing in the override print area.

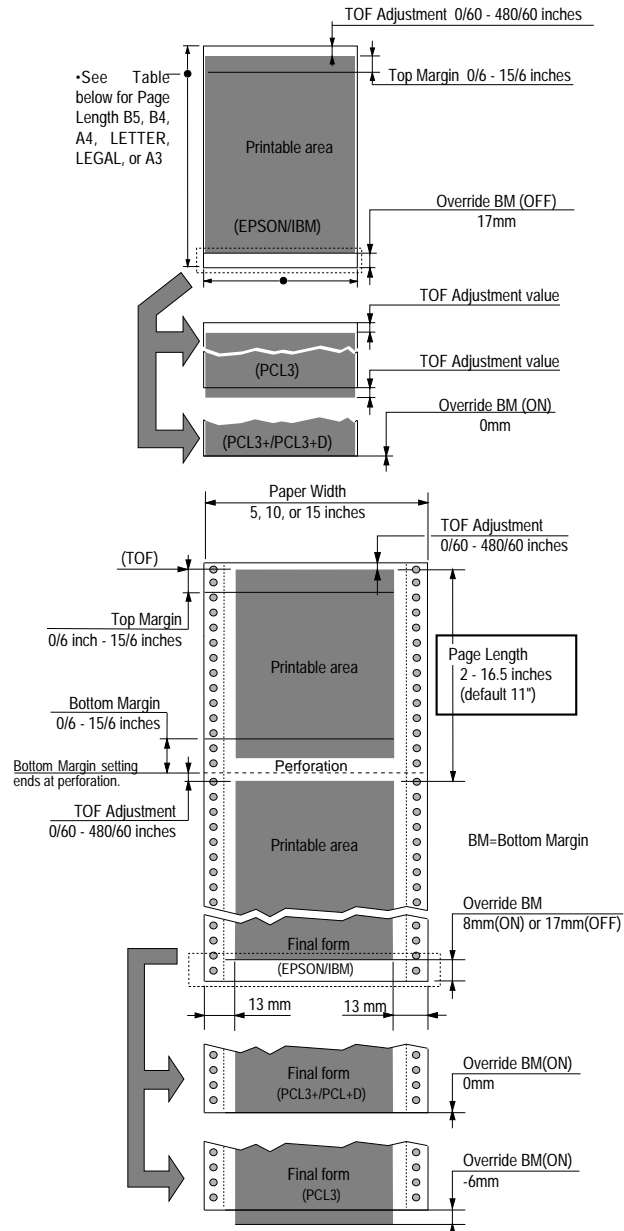

Label mode (valid only in fanfold setting)

Label mode is designed to prevent continuous forms labels from being peeled from the backing sheet and becoming jammed in the printer.

47 LABEL MODE

LABEL MD: NO Set the label protect mode off.
LABEL MD: YES Set the label protect mode on.

When the bottom edge of the label is positioned on the round surface of the platen for more than 10 seconds, the label is automatically repositioned away from the platen. When data is received by the printer, the labels are automatically positioned to the top of the next available label before printing begins. This function becomes effective when each label is equally apart and the same page length (min. 2 inches) is set for a single label.

Setting of "Paper out" detection

48 P.OUT DTCT

DETECT: PAGE END
DETECT: ANY POS

In the "ANY POS" setting, "Paper out" detection is functioning at the any position.

In the case of "PAGE END":

For fanfold paper: "Paper out" detection functions near the perforation only. After the detection, the print line feed data are not executed. With this function the printing format is maintained even after the sheet change.

For cut sheet paper: "Paper out" detection does not function within the paper size. The "Paper out" detection functions when the LF is exceeded over the paper size.

When a sheet shorter than the selection sheet size is printed, the printing is made even if paper out.

Cut sheet feeder type

A function for defining the CSF configuration. The CSF type, single tray can be set when the CSF is installed.

When single is selected, the paper tray (bin 1) can be selected by the BIN key on the front control panel.

49 CSF OPTION

NOT INSTALL
CSF: SINGLE
CSF: DOUBLE

Setting of the auto-scrolling position

50 SCROLL POS.

SCROLL: ANY POS
SCROLL: TOF ONLY

Set the position for executing auto-scrolling.

In the case of "TOF ONLY": Auto-scrolling is performed only when the present position is at TOF.

"ANY POS": If the perforation is between the paper cutter and printing head position, auto-scroll is performed at any position after a prescribed time after the printing.

Line Feed Speed

This function specifies the line feed speed.

The 1/2 LF speed feeds paper more stably. It is useful for thick paper, labeled sheets and multipart paper in continuous printing.

51 LF SPEED

SPEED: NORMAL

SPEED: 1/2

Communication enhancement

Interface type

This function selects the type of interface; the parallel interface or the serial interface. When this function is executed, the printer is initialized. See "Connecting the computer" section on page 12 for correct selection and connection of the interface cable.

60 INTERFACE

I/F: PARALLEL

I/F: SERIAL

I/F: AUTO

..... Parallel and serial interface are switched automatically.

SELECT IN signal (parallel interface)

When "SLCT IN: YES" is selected, the printer accepts the "select" or "deselect" command codes regardless of the SELECT IN signal from host system.

When "SLCT IN: NO" is selected, the printer ignores the "select" or "deselect" command codes regardless of the SELECT IN signal from host system.

When "SLCT IN: I/F" is selected, the printer functions according to the SELECT IN signal from host system.

61 SLCT IN CMD

SLCT CMD: YES

SLCT CMD: NO

SLCT CMD: I/F

Parity bit (serial interface)

This function selects the appropriate parity bit in the transmission data frame.

62 PARITY BIT

PARITY: NON

PARITY: EVEN

PARITY: ODD

Data length (serial interface)

This function selects the appropriate data length.

63 DATA LENGTH
LENGTH: 8 BITS
LENGTH: 7 BITS

Stop bit (serial interface)

This function selects the appropriate number of stop bits.

64 STOP BIT
STOP BIT: 1 BIT
STOP BIT: 2 BITS

Communication protocol (serial interface)

This function selects the appropriate communication protocol. Refer to the specification of your host system for selecting proper communication protocol.

65 PROTOCOL	
PROT.: DTR BUSY/READY protocol
PROT.: XON/OFF1 Set XON/XOFF 1
PROT.: XON/OFF2 Set XON/XOFF 2
PROT.: ETX/ACK	

Note: The difference in XON/XOFF 1 and 2: XON/XOFF 1 protocol sends XON code (11h) to host system at power-on while XON/XOFF 2 does nothing.

Communication speed (serial interface)

This function selects the appropriate baud rate for the data transmission speed.

66 BAUD RT
SPEED: 38400 B
SPEED: 19200 B
SPEED: 9600 B
SPEED: 4800 B
SPEED: 2400 B
SPEED: 1200 B
SPEED: 600 B
SPEED: 300 B

Serial error check (serial interface)

This function selects the printer's response to a serial data transmission error. The serial data transmission error includes a parity error, framing error, and over-run error. If "PRINT" is enabled, the data in error is printed as an asterisk(*). If "IGNORED" is enabled, the data in error is discarded.

67 SERIAL ERROR

S.ERROR: PRINT

S.ERROR: IGNORED

CTS signal (serial interface)

This function accepts or ignores the CTS (Clear to Send) signal from the host.

68 CTS ENABLE

CTS: NO

..... Ignores the CTS signal

CTS: YES

..... Functions according to the CTS signal from the host

CD signal (serial interface)

This function accepts or ignores the CD (Carrier Detect) signal from the host.

69 CD ENABLE

CD: NO

..... Ignores the CD signal

CD: YES

..... Functions according to the CD signal from the host

DSR signal (serial interface)

This function accepts or ignores the DSR (Data Set Ready) signal from the host.

70 DSR ENABLE

DSR: NO

..... Ignores the DSR signal

DSR: YES

..... Functions according to the DSR signal from the host

Communication buffer size

This function selects the maximum size of the input buffer.

When the selection of this function is completed, the printer is initialized.

The buffer size affects the signal protocol in serial data communication. In these protocols the printer's busy/ready state changes according to the data remaining values in the input buffer described below.

71 BUFFER SIZE

B.SIZE: 64 KB
 B.SIZE: 8 KB
 B.SIZE: 128 B

BUFFER SIZE	Ready to Busy (CIN)	Busy to Ready (CRN)
64k byte	1k byte	3k byte
8k byte		
128 byte	32 byte	64 byte

Note: When the remaining data capacity of the input buffer is smaller than CIN, the printer becomes busy. This state continues until the remaining capacity of the buffer is larger than CRN.

Busy/ACK timing (parallel interface)

This function selects timing to activate the ACK signal for 8 μ seconds (type 1) before, 4 μ seconds (type 2) before, or simultaneously synchronized (type 3) with the busy signal going low.

72 BUSY/ACK

TIMING: TYPE 1
 TIMING: TYPE 2
 TIMING: TIPE 3

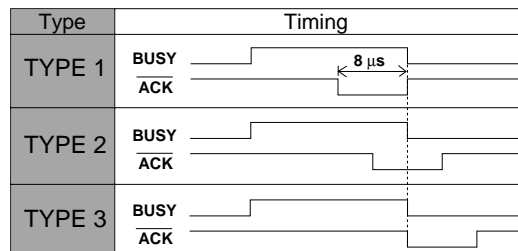

Data latch timing (parallel interface)

This function selects timing to latch the data signals at the rising edge (type R) or falling edge (type F) of the STROBE signal.

73 DATA LATCH

LTCH: TYPE F.
 LTCH: TYPE R.

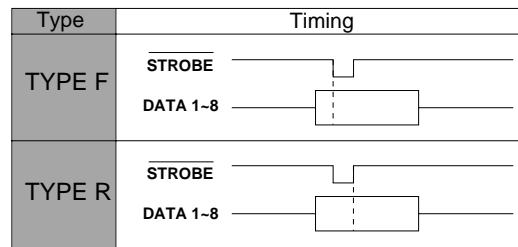

Setting of whether ERROR/PE signals are output or not

Setting is made whether or not ERROR and PE signals for the parallel interface are output.

When "NO" is selected,

ERROR signal remains HIGH, and PE signal remains LOW, even if Error status.

74 ERROR STATUS

STATUS SIG.:YES
 STATUS SIG.:NO

Miscellaneous

Print direction

This function selects either pre-directional printing, bi-directional printing, or uni-directional printing. Software commands to control the printing direction will override this selection. Particular characters such as IBM graphic characters are always printed unidirectional.

80 PRINT DIR

PRINT: PRE-DIR
PRINT: UNI-DIR
PRINT: BI-DIR

..... Defaults to bi-directional printing

- Pre-directional printing:
Whenever a double pass of the print head is required, the direction of the second pass is the same as that of the first pass. This logic-seeking, unidirectional printing can be used, therefore, in modes such as double strike and double height printing. The logic seeking capability is executed before the first pass of the print head. The printing direction of all passes is the same as that of the first pass.
- Bi-directional printing:
Successive passes of the print head alternate between the left-right and right-left direction.
- Uni-directional printing:
Data is always printed in a single direction from the left to the right.

LCD display language

This function selects the display language for the printer's display window (LCD).

81 DISPLAY LANG

LANG: ENGLISH
LANG: DEUTSCH
LANG: FRANCAIS
LANG: ESPANOL
LANG: ITALIANO

..... English
..... Germany
..... French
..... Spanish
..... Italian

Invert LCD display

This function sets up-side down text display in the LCD. Use with the reverse control panel sheet. (See page 136)

82 INVERT DISP

INVERT: NO
INVERT: YES

Software controlled setup

This function enables/disables the special software commands that are designed to control most of the extended setup options from host. See "Printer setup command codes" section in Appendix B.

83 SOFTWARE SET

SOFTWARE: NO
SOFTWARE: YES

Lock the RESET key

This function locks up the **RESET** key during the online mode in order to avoid an accidental reset during printing.

84 RESET LOCK

LOCK: NO
LOCK: YES

Setting ENERGY STAR

Set the power conservation standby mode.

When this mode is valid, if the standby mode continues about 14 minutes after printing, the power conservation mode is engaged. Switching to the normal mode is effected when any print action is performed.

85 SLEEP MODE

SLEEP MODE: YES
SLEEP MODE: NO

Saving user setup options

This function saves the current setup into one of three memory areas.

Press the **ENTER** key to store the current setup in the desired memory area. This does not affect the current setting. See "Loading user setup option" for the preprogrammed setups.

86 SAVE SETUP

SAVE: MEMO 1
SAVE: MEMO 2
SAVE: MEMO 3

Printing list of setting options

This function prints the list of the current basic setup options, extended setup options, factory setup contents, or all the setups in the memory areas.

Press the **ENTER** key to start the selected item listing. This does not affect the current setting.

87 SETUP LISTING

LIST: MAIN	Lists current basic setup options
LIST: EXTEND	Lists current extended setup options
LIST: ALL SET	Lists all setup listings including user setups
LIST: FACTORY	Lists factory setup contents

6. SETTING THE APPLICATION SOFTWARE

About printer driver

Printer Driver is a section of your software that automatically translates instructions from the software to your printer.

For example, when using some application softwares, if you want to **boldface** or underline a word, the printer driver automatically translates your specific **boldface** or underline instruction on your application software to printer control command.

Different printers use different control codes for designating print styles. Therefore, it is important that when you install your software, you select the appropriate printer driver designed for your printer.

When WINDOWS 3.1, WINDOWS NT 3.51, 4.0, or WINDOWS 95, 98 is used, please install the Printer Driver attached to this printer.

When this printer is used in the MS-DOS or other environment, such as UNIX or OS/2, proceed as follows.

Printer driver selection

Select a suitable printer driver from the list of supported printers. This would include either the **Hewlett Packard RuggedWriter 480**, **Epson LQ-2550** or **IBM 2391**. Each of these printer drivers should allow you to access many of the features on your printer.

If this printer is not listed, look for the following printer drivers. While this should allow you to print your document with your printer, it probably will not allow you to access many features of the printer. A few of the choices you may see are given below in order of preferences.

<u>Hewlett Packard</u>	<u>Epson</u>	<u>IBM</u>
RuggedWriter 480	LQ-2500/2550	2390/2391
DeskJet 500	LQ-1050/1000	Proprinter XL24E
		Proprinter XL24

Notes:

1. *Set the emulation type in the extension setup options according to the selection of printer driver. For example, when you select the Epson LQ-2550 printer driver, you should set the emulation type to the Epson mode.*
2. *If the Desk Jet 500 driver, is selected, it is recommended to set up the printer's PCL MODE(extended setup 38) to PCL3+D.*

CONNECTING THE BP-9000 PRINTER IN THE HP ENVIRONMENT

Introduction

The HP emulation of the BP-9000 printer provides full compatibility with the HP2235A RuggedWriter 480 printer.

The BP-9000 also provides features and capabilities beyond those ever provided by the HP RuggedWriter printer. SEIKO Precision Inc. has provided a means for you to access these extra capabilities for any new applications that you may chose to print on the BP-9000.

The extra capabilities of the BP-9000 printer are enabled for access through a special control panel menu setting entitled "38 PCL MODE".

PCL Mode

- PCL3 MODE -Provides the basic RuggedWriter 480 emulation command set.
- PCL3+ MODE –Provides extra capability to the RuggedWriter 480 command set that allows you to access many BP-9000 printer features through extensions of the command set.
- PCL3+D MODE –Provides all features of PCL3+ and allows the vertical and horizontal positioning to be set in increments of 1/360". This mode provides a "limited" Deskjet capability, and is mainly intended for printing from Windows using the Deskjet 500 driver. Print output from this mode will not be identical to that of a Deskjet printer (300 vs. 360 dpi) but will be closer than the other 2 modes for this type of application.

Setup

The information provided below gives setup information of the basic printer RuggedWriter emulation, details of the command set extensions provided with PCL3+ and PCL3+D Mode, and information on configuring the Serial I/O to the various Term Types used by the HP System.

Refer to the setup sections 4 and 5 for details on using the Basic and Extended Setup configuration modes.

Configuring the Printer with the RuggedWriter Emulation

1. Set the printer menu item 10 EMULATION to "HP".
2. Set the printer menu item 38 PCL MODE to "PCL3".

Setting the PCL MODE to "PCL3" provides the command set identical with that of the HP RuggedWriter 480.

Extra Capabilities for new Applications

Listed below is a summary of the expanded command sets available for new applications. refer to the Appendix B, page 118 through 124 for details of using the expanded command sets.

PCL3+ Mode

This operation mode provides the following extended capabilities:

Escape Command	Description	Added Capability:
BEL	Activates the printer's bell	Bell is now active
ESC & k # W	Controls the print direction	Unidirectional, Bidirectional, Predirectional
ESC (# id	Assign the primary font	PC-850, ISO25, France 2, German2, Spain 3, Legal, Math7, Math-Symbol, ISO84 Portugal 2, ISO85 Spain 2
ESC) # id	Assign the secondary font	PC-850, ISO25, France 2, German2, Spain 3, Legal, Math7, Math-Symbol, ISO84 Portugal 2, ISO85 Spain 2
ESC (s # H	Sets the character pitch	15, 17.1, 24 cpi (primary)
ESC) s # H	Sets the character pitch	15, 17.1, 24 cpi (secondary)
ESC (s # T	Sets the primary typeface	Script, Orator, Orator-s, OCR-A, OCR-B
ESC) s # T	Sets the secondary typeface	Script, Orator, Orator-s, OCR-A, OCR-B
ESC * b # M	Select graphics data compression	Off, Mode1, Mode2, Mode3
ESC * t # R	Designates raster graphics resolution	60, 360 dpi

PCL3+D Mode

This mode provides all of the capabilities described above plus the following:

Escape Command	Description	Added Capability:
ESC * p # X	Sets horizontal positioning by dot	1/360"
ESC * p # Y	Sets vertical positioning by dot	1/360"

Saving Your Setup

Once you have completed your printer set-up, the configuration can be saved as a User setup.

Use the printer's Extended Setup menu 86 SAVE SETUP and save your setting as either MEMO 1, MEMO 2, or MEMO 3.

This saved setup may be re-initialized at any time using 8 SELECT SETUP to select the applicable User setup MEMO 1, MEMO 2, or MEMO 3.

7. Troubleshooting

If an error occurs during printing, you will get several warnings. A buzzer sounds, P.OUT lamp blinks, and an error message appears in the display window of the front control panel.

❑ Error Messages

<i>Error Message</i>	<i>Cause and Solution</i>
CARRIAGE ERROR	The printer cannot detect the print head position. ◆ Turn off the printer immediately. After a brief wait, turn on the printer again.
RAM ERROR (NO LCD DISPLAY The POUT lamp blinks and the buzzer sounds after power on.)	Internal RAM does not function properly. ◆ Turn the printer off and back on again. If the error persists, consult your dealer.
FAN ERROR	Abnormal fan operation is detected.
HEAD PROTECTION (ON LINE lamp blinks.)	Long continuous printing may overheat the print head. ◆ The printer stops temporarily and restarts automatically when the print head temperature lowers to a safe level.
PAPER ERROR (Buzzer sounds 3 times.)	Paper jam or improper paper operation has occurred. ◆ If paper parking is not completed, press the PARK key. Otherwise reload the paper.
PAPER OUT	Paper is not loaded in the printer. ◆ Load paper (pages 13 and 14).
COVER OPEN	One of the printer covers is open. ◆ Close the cover to restart the operation.
POWER DOWN	Abnormal current is detected. ◆ The printer is automatically turn off. Stop using the printer, and contact the dealer.

□ Troubleshooting guide

<i>Problem</i>	<i>Cause and Solution</i>
POWER lamp fails to light	<ul style="list-style-type: none"> ◆ Power cord not connected. ◆ Blown fuse in the printer.
Printer stops or slows down on printing	<ul style="list-style-type: none"> ◆ Print head has overheated. Wait until it has cooled down.
P.OUT lamp lights incorrectly	<ul style="list-style-type: none"> ◆ Paper detect sensor may be damaged. ◆ Sensor hole is clogged.
Poor quality printing or smudging of the paper	<ul style="list-style-type: none"> ◆ Old or worn out ink ribbon needs to be replaced. ◆ Head adjustment lever is not set correctly. ◆ Head may need to be cleaned or replaced.
Some characters miss printing	<ul style="list-style-type: none"> ◆ Ribbon cassette is not properly installed.
Incorrect character printed	<ul style="list-style-type: none"> ◆ Host system control and data code may not match the printer's setup.
Paper not advancing	<ul style="list-style-type: none"> ◆ Incorrect paper select lever setting.
Fanfold paper slips	<ul style="list-style-type: none"> ◆ Stack of fanfold paper behind the printer is placed crookedly. ◆ The paper select lever is in the single sheet setting.
Extra line feed	<ul style="list-style-type: none"> ◆ The automatic carriage return option in the extended setup options is set incorrectly.
Paper jam	<ul style="list-style-type: none"> ◆ Paper is curled. ◆ Move the paper select lever to the continuous paper setting and carefully remove the jammed paper.
Paper Bail abnormal operation	<ul style="list-style-type: none"> ◆ Turn off the printer and wait one minute, and then turn it back on again. Consult your dealer if the error persists.

❑ Input Hexadecimal Dump Mode

The Input hexadecimal dump capability of the printer enables monitoring of data as it is sent to the printer. Each Escape Sequence, Control Code, and ASCII character sent from the computer to the printer is printed in a two-digit hexadecimal format. Such printing is initiated after 16 bytes of data have been transmitted to the printer. Hexadecimal values and their corresponding ASCII characters between the values 20h to 7Eh are printed on each line.

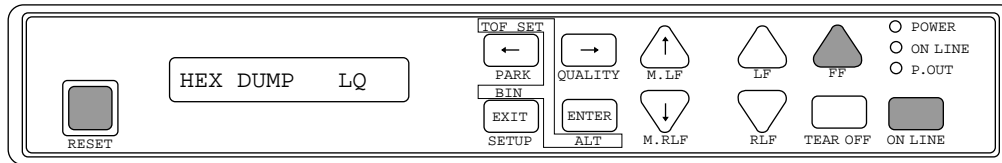

To run this mode in draft printing

Press the **FF** key while turning ON the printer or pressing the **RESET** key. Hold down the **FF** key until the LCD displays "HEX DUMP DRAFT"

To run this mode in LQ printing

Press the **FF** and **ON LINE** keys simultaneously while turning ON the printer or pressing the **RESET** key. Hold down the both **FF** and **ON LINE** keys until the LCD displays "HEX DUMP LQ"

To terminate this mode

Press the **RESET** key or turn off the power.

Example

```
10 REM HEXADECIMAL DUMP LIST EXAMPLE
20 OPEN "LPT1:"AS #1
30 WIDTH #1,255
40 PRINT #1,"ABC";CHR$(13);CHR$(10);
50 PRINT #1,"123";CHR$(13);CHR$(10);
60 PRINT #1,"HENRY IS HANDSOME"
70 END
```

```
00000 41 42 43 0D 0A 31 32 33 0D 0A 48 45 4E 52 59 20 ABC..123..HENRY
00010 49 53 20 48 41 4E 44 53 4F 4D 45 0D IS HANDSOME.
```

ASCII characters are printed according to hexadecimal codes of the data. Codes other than 1Bh and 20h to 7Eh are printed as "." (2Eh). For the code 1Bh, "E" is printed in draft mode and "ESC" is printed in LQ mode.

During the Hexadecimal mode, the **SETUP**, and **QUALITY** keys are disabled.

8. Maintenance

❑ Cleaning

Minimum periodical cleaning will ensure the maximum performance from your printer. Do not spill or splash cleaning liquid inside the printer. Please refer to the "Printer cover removal" on page 64 to remove the covers for cleaning.

Before cleaning the printer, be sure to turn off the power and disconnect the power cord. Power may be required to clean the platen.

-
- Platen** ◆ Use a platen cleaner, or any weak alcohol solvents, to remove any ink from the platen and bail rollers. Do not apply any other liquid chemical to the platen.

Even with a specified platen cleaner, frequent use of the liquid is not recommended. Apply only when it is necessary.

-
- Inside the printer** ◆ Use a vacuum cleaner to remove paper dust and particles inside the printer. A small brush is suitable for removing paper dust from hard-to-get-at areas.

-
- Exterior Casings** ◆ Clean with a soft cloth dampened with a mild detergent. Never use organic solvents such as alcohol or thinner.
-

FPC cable plastic binder

Make sure that the binder clamps the cable securely.

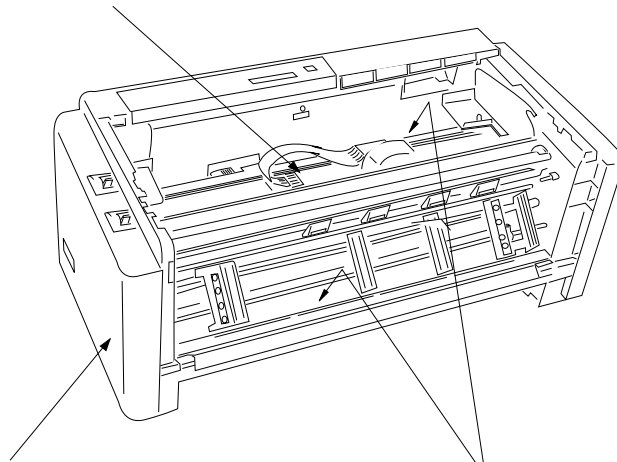

Exterior Casings
Clean with a soft cloth dampened with a mild detergent.

Inside the printer
Thoroughly vacuum these areas.
Remove any collected paper dust and particles.

❑ Lubrication

In the case of heavy use of the printer, apply a specified lubricating oil only to the front and rear metal carriage bar. When applying the lubricant to the carriage bars, spread the oil by manually moving the print head back and forth along the carriage bar.

Consult your dealer to obtain the recommended lubricating oil. Do not use an unspecified oil, or it may reduce the printer's performance drastically.

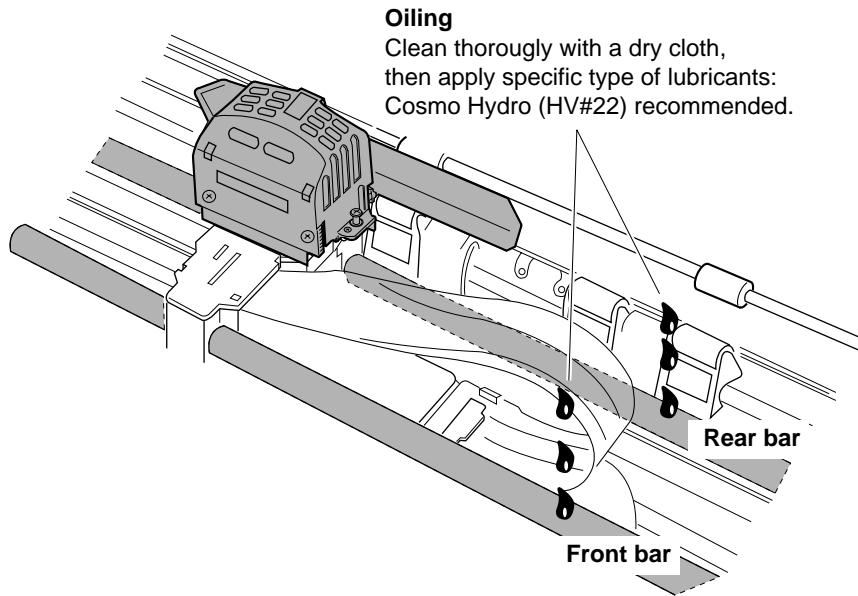

❑ Printer cover removal

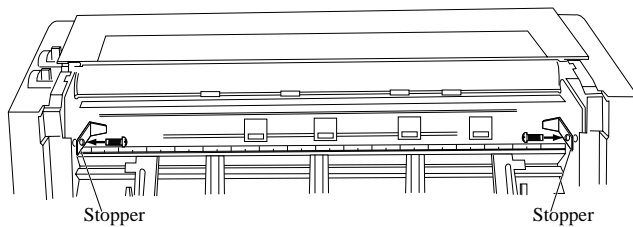

Rear Top Cover Removal

- ◆ Remove the Rear Cover.
Open the Rear Cover to the level position and pull it.
- ◆ Remove the two stoppers for the Rear Top Cover.
Detach the two screws to remove the two Stoppers.
- ◆ Remove the Rear Top Cover.
Slide the Rear Top Cover toward the rear and raise it to vertical position and lift straight upward.

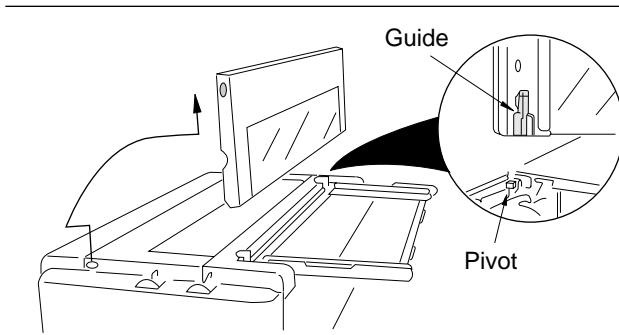

Printer Cover

- ◆ Open the front cover to an upright position, then lift and remove the cover.

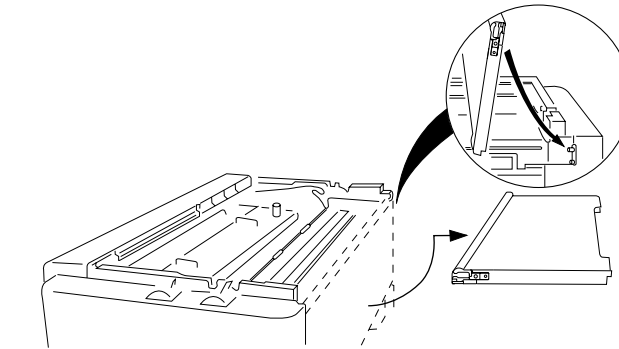

Rear Cover

- ◆ Open the rear cover from the bottom edge of the cover and pull it away from the printer to remove.

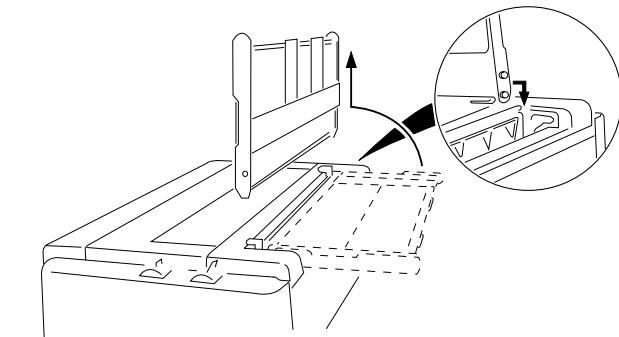

Paper Rack

- ◆ Slide both paper guides to the extreme left and right edges of the paper rack. Raise the rear end to stand vertically and lift straight upward to remove.

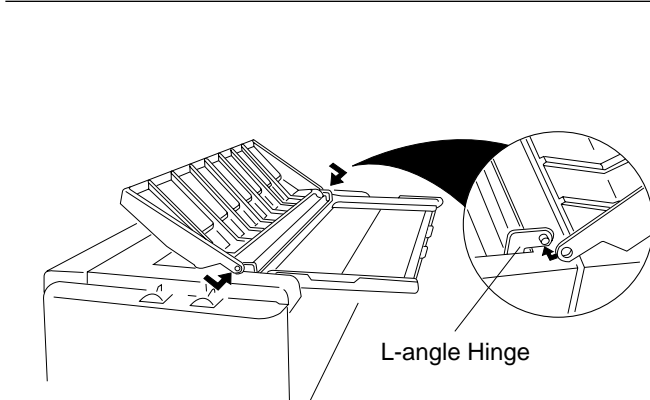

Sound Seal Cover

- ◆ Push out on the outer edge of the sound seal cover where it connects to the L-angle from the printer while pushing the stud of the L-angle out of the hole. Then remove the whole cover.

□ Vertical alignment mode

The vertical alignment mode serves to compensate for the slippage of the vertical printing positions, that occurs due to individual differences and age distortion of the printer.

This mode has two features: print start alignment as A-MODE and bidirectional print alignment as B-MODE. The print start adjustment aligns the print position of two different print modes at the left margin. While the bidirectional print adjustment aligns the vertical dot mis-positioning within one print mode in bidirectional printing. Because of their correlation, always set the bidirectional alignment after the print start adjustment.

The print mode used for these adjustments is categorized as 11 and 12 groups (A-MODE 1 to 11, B-MODE 0 to 11) that differ in printing speed. By aligning characters with the typical character mode of each group, the character modes within the group are automatically adjusted, e.g. Draft pica printing mode belongs to MODE 0 group.

Operation and printing pattern

Before performing the adjustment mode, make sure that the ribbon cassette and at least 10-inch wide paper are properly installed in the printer.

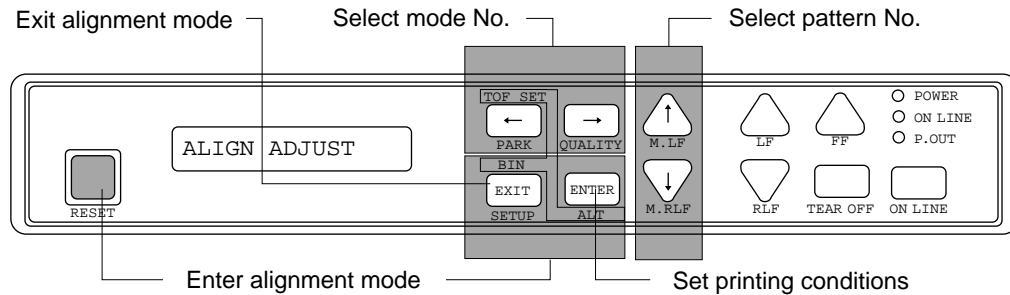

- 1 Press the **SETUP** and **ALT** keys simultaneously while turning ON the printer or pressing the **RESET** key. Hold down the both **SETUP** and **ALT** keys until the LCD displays "ALIGN ADJUST".

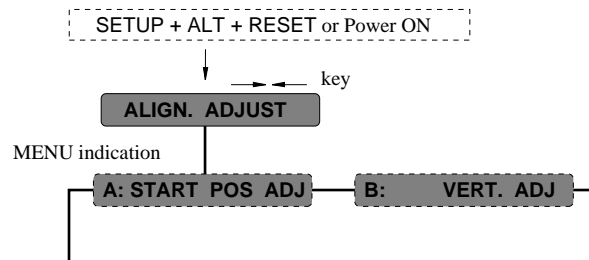

- 2 Press the left or right arrow key to select A-MODE for print start adjustment or B-MODE for bidirectional print adjustment. Then press the **ENTER** key to enter. The operation on either alignments is done in the same manner. Always select B-MODE after A-MODE is set or has been set correctly.

- 3 13 patterns from 0 to 12 are printed in accordance with the printing conditions. The pattern of the present printing condition is indicated with asterisks (*).

PRINTED PATTERNS EXAMPLE

START POSITION ALIGNMENT

```

A-MODE 1
  0   1   2   3   4   5  6*  7   8   9  10  11  12
>====> ████  ...  ████  ████  ████  ████  ████  ████  ████  ████  ████  ████  >====>

A-MODE 2
  0   1   2   3   4   5  6*  7   8   9  10  11  12
>====> ████  ...  ████  ████  ████  ████  ████  ████  ████  ████  ████  ████  >====>

A-MODE 3
  0   1   2   3   4   5  6*  7   8   9  10  11  12
>====> ████  ...  ████  ████  ████  ████  ████  ████  ████  ████  ████  ████  >====>

A-MODE 4
  0   1   2   3   4   5  6*  7   8   9  10  11  12
>====> ████  ...  ████  ████  ████  ████  ████  ████  ████  ████  ████  ████  >====>

A-MODE 5
  0   1   2   3   4   5  6*  7   8   9  10  11  12
>====> ████  ████  ████  ████  ████  ████  ████  ████  ████  ████  ████  ████  >====>

A-MODE 6
  0   1   2   3   4   5  6*  7   8   9  10  11  12
>====> ████  ████  ████  ████  ████  ████  ████  ████  ████  ████  ████  ████  >====>

A-MODE 7
  0   1   2   3   4   5  6*  7   8   9  10  11  12
>====> ████  ████  ████  ████  ████  ████  ████  ████  ████  ████  ████  ████  >====>

A-MODE 8
  0   1   2   3   4   5  6*  7   8   9  10  11  12
>====> ████  ████  ████  ████  ████  ████  ████  ████  ████  ████  ████  ████  >====>

A-MODE 9
  0   1   2   3   4   5  6*  7   8   9  10  11  12
>====> ████  ████  ████  ████  ████  ████  ████  ████  ████  ████  ████  ████  >====>

A-MODE 10
  0   1   2   3   4   5  6*  7   8   9  10  11  12
>====> ████  ████  ████  ████  ████  ████  ████  ████  ████  ████  ████  ████  >====>

A-MODE 11
  0   1   2   3   4   5  6*  7   8   9  10  11  12
>====> ████  ████  ████  ████  ████  ████  ████  ████  ████  ████  ████  ████  >====>

```

Description of Patterns

- A pattern describes the type of printing conditions for each mode.
- A number with "*" in the printing example represents the printing condition being set at present.
- The dots pattern (" . ") indicates the printing condition in between the adjacent patterns, the setting is valid.

- 4 Make sure, the vertical alignment of the chosen print pattern which is marked with "*" is the best aligned among the 0-12 patterns.
If not the best, you may change to the best aligned one among 0-12.

8. Maintenance (Vertical alignment mode)

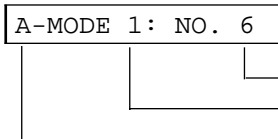

LCD Description	Key Operation
Pattern No. (0-12)	Up and down arrow keys
Mode No. (1-11 or 0-11)	Left and right arrow keys

EXAMPLE (To change the pattern No. 6 to 7 in A-MODE 4.)

A-MODE 3

>---->	0	1	2	3	4	5	6*	7	8	9	10	11	12
>---->	HHH	HHH	HHH	HHH	HHH	HHH	HHH	HHH	HHH	HHH	HHH	HHH	HHH

Best aligned is chosen

A-MODE 4

>---->	0	1	2	3	4	5	6*	7	8	9	10	11	12
>---->	HHH	HHH	HHH	HHH	HHH	HHH	HHH	HHH	HHH	HHH	HHH	HHH	HHH

Best aligned

Bad aligned is chosen

5 Pressing the Left and Right arrow key changes the Mode number between 1 to 11 to select the best pattern within the mode.

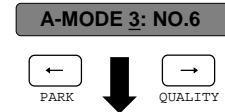

6 Pressing the Up and Down arrow key changes the pattern number between 0 to 12 to select the best pattern within the mode.

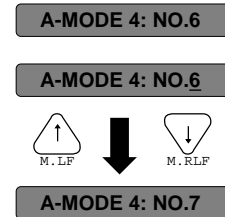

7 By scrolling to the desired pattern number and pressing the **ENTER** key, the selected printing condition is set. When the condition is set, the corrected pattern of the selected print mode is printed out.

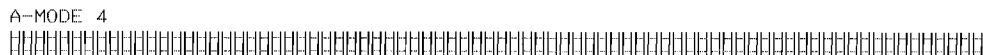

8 Repeat the steps 5 through 7 until the start position adjustment is completed.

9 Pressing the **EXIT** key to exit from the start position adjustment (A-MODE). The bidirectional printing adjustment (B-MODE) takes place automatically and the LCD indicates "B: VERT ADJ".

10 Press the **ENTER** key to enter the bidirectional printing adjustment (B-MODE).

11 Repeat the steps 5 through 7 until the bidirectional printing adjustment is completed.

12 After all adjustments are completed, press the **EXIT** key, then the LCD indicates "PRESS RESET SW". By pressing the **RESET** key, the printer exits from this vertical alignment mode.

9. Bar code and enlarged character

The printer can print bar codes and enlarged characters.

To activate the bar code and enlarged character function, set #27 BARCODE/ENLARGED CHAR to MODE 1 or MODE 2 in the EXTENDED SETUP MODE.

This function is applicable to the EPSON or IBM or HP mode. This section describes the outline and details of the bar code and enlarged character function.

□ Outline of bar code function

The printer has 14 types of bar codes.

Software commands and options #27 to #29 on the EXTENDED SETUP MODE are used to print bar codes and enlarged characters.

The software commands are unique to the printer. See the following pages for details of these commands.

1. Industrial 2 of 5	8. Code 128
2. Interleaved 2 of 5	9. EAN-8
3. Matrix 2 of 5	10. EAN-13
4. Codabar	11. UPC-A
5. Code 11	12. UPC-E
6. Code 39	13. Postnet
7. Code 93	14. Element (Created in elements.)

□ Makeup of bar code

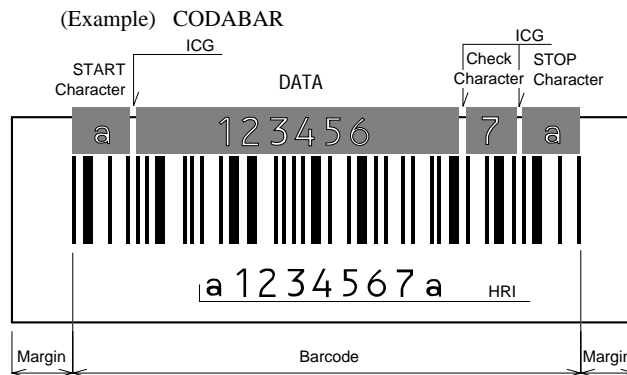

- Start Character : Initial character of data
- DATA : Alphanumeric data
- Check Character : Character for check errors in read data
- Stop Character : Last character of data
- HRI : Human Readable Interpretation
- ICG : Gap between characters (Inter Character Gap)
- Margin : Data-free portions must be provided on both sides.
Each data-free portion must be approximately ten times as wide as the narrow space (NS).

Bar Code function

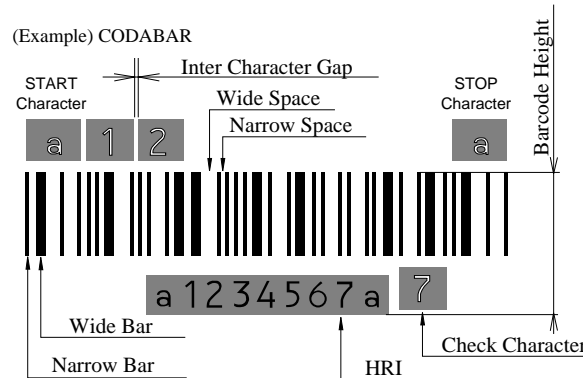

□ Bar Code command

	Function	Command
1.	Bar code type	DC4 DC4 T
2.	Element width	DC4 DC4 E
3.	Bar code height	DC4 DC4 H
4.	Setting HRI on and off	DC4 DC4 I
5.	HRI font	DC4 DC4 F
6.	Check character	DC4 DC4 C
7.	Starting the bar code data sequence	ESC SI
8.	Ending the bar code data sequence	ESC SO
9.	Bar code data sequence	DC4 DC4 B
10.	Printing density	DC4 DC4 D
11.	Guard bar expansion	DC4 DC4 G
12.	Start and stop characters	DC4 DC4 N
13.	Bar code rotational angle	DC4 DC4 R
14.	Disabling HRI of the start and stop characters	DC4 DC4 S
15.	Value input mode	DC4 DC4 V
16.	Initializing the bar code mode	DC4 DC4 @

(1) DC4 DC4 T

Bar code type:

Format: ASCII DC4 DC4 T n
 Hex 14 14 54 n
 Decimal 20 20 84 n

Function: Specifies the bar code type

n=0 Industrial 2 of 5 7 Code128
 1 Interleaved 2 of 5 8 EAN-8
 2 Matrix 2 of 5 9 EAN-13
 3 Codabar 10 UPC-A
 4 Code11 11 UPC-E
 5 Code39 12 Postnet
 6 Code93 255 Element Print

Parameter 255 (Element print) is used to print a bar code which is input element by element. It can print a bar code which is not supported by the printer and is represented by combining elements. Since data is input by elements, HRI printing is not performed and no check digit is added to the bar code. The start and stop characters is also not added.

(2) Element width: DC4 DC4 E

Format:	ASCII	DC4	DC4	E	n1	n2
	Hex	14	14	45	n1	n2
	Decimal	20	20	69	n1	n2

Function: Specifies the $n2/120''$ or $n2/180''$ width of the element $n1$.
 $(1 \leq n2 \leq 127)$

$120''$ or $180''$ is specified with the DC4 DC4 D command.

$n1 = 0$:	Narrow bar	3: Wide space
1:	Wide bar	4: Inter-character gap
2:	Narrow space	

The narrow bar width or narrow space is used as the element width for Code 93, Code 128, EAN-8, EAN-13, UPC-A, and UPC-E.

One element width of bar 1: Narrow bar width

One element width of space 1: Narrow space width

The midium bar or wide space width is used as the midium element width for Code 11. The wide element width is (wide bar width x 2 - narrow bar width).

This setting is not valid for Postnet.

The inter-character gap means the space between each set of codes of a bar code which begins with a bar and ends with a bar.

(3) Bar code height: DC4 DC4 H

Format:	ASCII	DC4	DC4	H	n
	Hex	14	14	48	n
	Decimal	20	20	72	n

Function: Sets the bar code height to $n/12''$. ($0 \leq n \leq 120$)

The currently set line feed pitch serves as the bar code height when is set to 0. This setting is not valid for Postnet.

(4) Setting HRI on and off: DC4 DC4 I

Format:	ASCII	DC4	DC4	I	n
	Hex	14	14	49	n
	Decimal	20	20	73	n

Function: Specifies whether or not to print an HRI. Also specifies the HRI printing position if an HRI is to be printed.

$n = 0$: HRI not printed.

1: HRI printed below the bar code symbol.

2: HRI printed above the bar code symbol.

No HRI printed for Postnet or Element regardless of this setting.

9. Bar code and enlarged character

(5) HRI font: DC4 DC4 F

Format:	ASCII	DC4	DC4	F	n
	Hex	14	14	46	n
	Decimal	20	20	70	n

Function: Selects the font of printing the HRI.

n = 0: Currently selected font

1: OCR-A

2: OCR-B

This setting is not valid for Postnet or Element.

(6) Check character: DC4 DC4 C

Format:	ASCII	DC4	DC4	C	n
	Hex	14	14	43	n
	Decimal	20	20	67	n

Function: Specifies whether to add a check character automatically.

n = 0: No check character is added. (If a check character is needed, the user must send bar code data.)

1: A check character is added. (The check character is not printed in the HRI when Code 93 or Code 128 is selected.)

If the Codabar or Element is selected, no check character is added regardless of this setting.

The following shows the methods of determining the check characters and bar code types. (For details, see "Calculating the check character" below.)

Modulus 10 Industrial 2 of 5, Interleaved 2 of 5, Matrix 2 of 5, EAN, UPC, Postnet

Modulus 11 Code 11 (Dual Check character)

Modulus 16 Codabar

Modulus 43 Code 39

Modulus 47 Code 93 (Dual Check character)

Modulus 103 Code 128

(7) Beginning of the bar code data sequence: ESC SI

Format:	ASCII	ESC	SI
	Hex	1B	0F
	Decimal	27	15

Function: Indicates the beginning of a bar code data sequence.

Data between this and the end command of the bar code data sequence is regarded as bar code data.

This command is valid only when #27 BARCODE/LABEL MODE is set to MODE 2 in the EXTENDED SETUP MODE.

(8) End of the bar code data sequence: ESC SO

Format:	ASCII	ESC	SO
	Hex	1B	0E
	Decimal	27	14

Function: Indicates the end of a bar code data sequence.

This command is valid only when #27 BARCODE/LABEL MODE is set to MODE 2 in the EXTENDED SETUP MODE.

(9) Bar code data sequence: DC4 DC4 B

Format:	ASCII	DC4	DC4	B	n	d1	d2 ... dk
	Hex	14	14	42	n		
	Decimal	20	20	66	n		

Function: Specifies the number (“n”) of data to be regarded as bar code data.

$$00 \leq n \leq 68$$

$$00 \leq dk \leq 255$$

$$00 \leq k \leq 68$$

If the Element is selected; $0 \leq n, dk, k \leq 255$

This command is valid when #27 BARCODE/LABEL MODE is set to MODE1 or MODE2 in the EXTENDED SETUP MODE.

(10) Printing density: DC4 DC4 D

Format:	ASCII	DC4	DC4	D	n
	Hex	14	14	44	n
	Decimal	20	20	68	n

Function: Specifies the density of printing bar code symbols (in the horizontal direction).

Specifies the unit of element width.

n = 0: Bar code symbols are printed at 120 dpi. (Default value)

1: Bar code symbols are printed at 180 dpi.

If a bar code is rotated by 90 or 270 degrees using the DC4 DC4 R (bar code rotational angle) command, a bar code is printed at 120 dpi horizontally and 180 dpi vertically.

(11) Guard bar expansion: DC4 DC4 G

Format:	ASCII	DC4	DC4	G	n
	Hex	14	14	47	n
	Decimal	20	20	71	n

Function: Specifies whether or not to expand EAN or UPC guard bars.

n = 0: Guard bars are not expanded.

1: Guard bars are expanded. (Default value)

9. Bar code and enlarged character

(12) Start and stop characters: DC4 DC4 N

Format:	ASCII	DC4	DC4	N	n1	n2
	Hex	14	14	4E	n1	n2
	Decimal	20	20	78	n1	n2

Function: Specifies the Codabar start or stop character. n1 selects the start or stop character. n2 specifies a code of the start or stop as shown below.

n1 = 0: Start character

1: Stop character

n2 = a, b, c, d, t, n, *, or e.

When power is turned on, "a" is selected as the start or stop character.

(13) Bar code rotational angle: DC4 DC4 R

Format:	ASCII	DC4	DC4	R	n
	Hex	14	14	52	n
	Decimal	20	20	82	n

Function: Specifies the rotational angle of the bar code in units of 90 degrees.

n = 0: 0° (Default value)

1: 90°

2: 180°

3: 270°

(14) Disabling HRI of the start and stop characters: DC4 DC4 S

Format:	ASCII	DC4	DC4	S	n
	Hex	14	14	53	n
	Decimal	20	20	83	n

Function: Specifies whether or not to print the start or stop character in the for Codabar, Code 11, Code 39 or Code 93.

n = 0: The start or stop character is printed in the HRI.

(Default value)

1: The start or stop character is not printed in the HRI.

(15) Value input mode: DC4 DC4 V

Format:	ASCII	DC4	DC4	V	n
	Hex	14	14	56	n
	Decimal	20	20	86	n

Function: Specifies whether bar code sequence data is regarded as the normal character code or a character value when Code 128 is selected.

n = 0: Data is regarded as normal character code. (Default value)

1: Data is regarded as a character value.

If data is regarded as the normal character code, the printer automatically move the subset or inserts a shift code according to the data.

(16) Initializing the bar code mode: DC4 DC4 @

Format:	ASCII	DC4	DC4	@
	Hex	14	14	40
	Decimal	20	20	64

Function: Initializes the bar code mode.

The following show the default settings for bar code.

Bar code type:	SETUP
Narrow bar width:	SETUP
Wide bar width:	SETUP
Narrow space width:	SETUP
Wide space width:	SETUP
Inter- character gap:	SETUP
Bar code height:	SETUP
Setting HRI:	Below the bar code symbol
HRI font	OCR-B
Check character:	Added
Printing density:	1/120"

□ Data processing in the bar code data sequence

- *In a bar code data sequence following ESC SI, any codes other than the ESC code are regarded as bar code data. Continuous two-byte ESC codes (ESC + ESC) are regarded as a one-byte ESC bar code.*
- *In a barcode data sequence following ESC SI, SO ESC+ SI and ESC + ESC are valid and the other ESC sequence are ignored. The ESC code and the following data, two bytes in all, are discarded.*
- *When a start or stop character code (e.g., * code of Code 39) is input in a bar code data sequence, the bar code data sequence stops if bar code data has already been input in that sequence. The data that was input is valid (and converted into a bar code). If not, the bar code data sequence does not stop and the code is discarded.*
- *When 68 bytes of data is input, the bar code data sequence ends automatically. When Code 93 or Code 128 is selected, the bar code data sequence ends when the amount of input data, including the automatically inserted control character, reaches 68*

□ **Printing bar codes**

- *Bar codes are printed at normal LQ 10 cpi (158 cps) print speed when the printing density is 120 dpi or at Dark 1 LQ 10 cpi (79 cps) print speed when the printing density is 180 dpi. (This does not apply to printing paths involving HRI printing or duty control.)*
- *Bar codes and normal characters are printed separately. When the bar code data sequence start code is processed, print data other than bar code data contained in the buffer is printed. When print data other than bar code data is input, bar code data contained in the buffer is printed.*
- *Like the right margin overflow processing for character data, data preceding bar code data is printed and the bar code data is printed from the left margin on the following line if the data exceeds the right margin.
If bar code data cannot be printed between the left and right margins, the bar code data is ignored.*
- *If the vertical line feed pitch is smaller than the bar code height, reverse feeding is performed to move to the following printing position. (If an out-of-paper error is detected in a bar code printing path, the following paths are printed on the following form.)*

□ **HRI**

- *The HRI is adjusted to the center of the bar code symbol width and printed at 10 cpi unless EAN or UPC guard bar expansion is executed. If EAN or UPC guard bar expansion is executed, an HRI is printed at the equal space between the center guard bar and the left or right guard bar.
If the HRI width is greater than the bar code symbol width, the HRI printing pitch is reduced to print the HRI in the same width as the bar code symbol width.*
- *The HRI is printed below a bar code symbol, the vertical printing position is lower than the printing start position by (bar code height - 1/6"). If it is printed above the bar code symbol, the vertical printing position is higher than the printing start position by (1/6" - 24/180").*
- *When Code 11 is selected, small triangle (\triangle) and large triangle (\triangle) are printed as the start and stop characters, respectively. (This does not depend on the setting of the check character.)*
- *When Code 93 is selected, white squares (\square) are printed as the start and stop characters, and a black square (\blacksquare) is printed as the control character. A printable character expressed in combination with the control character is printed as is. (For example, 61H is printed as 'a', not ' \blacksquare A'.)*
- *When Code 128 is selected, black rhombuses a (\blacklozenge) are printed instead of non-printable*

❑ Error processing

- *If a character code that is not valid for the selected bar code type is input, the character code is not converted into a bar code symbol but is printed as a character. If the bar code has a start or stop character added to the HRI, the start or stop character is printed. ‘ ☒ ’ is printed instead of an invalid character.*
- *If an incorrect number of data are input to form a bar code which should have a specific number of data, are input data is not converted into a bar code symbol but is printed as is.*
- *If incorrect data is input in the UPC-A format and cannot be converted into the UPC-E format, the input data is not converted into a bar code symbol but is printed as is. (For the rules of converting the UPC-A format into the UPC-E format, see “UPC-E conversion rule” below.)*

❑ Code 128 subset transition rule

- *The following shows the transition conditions from subset A to subset B.*
 1. *Input a character code unique to subset B (60H to 7FH) when subset A is selected.*
 2. *Then input a character code unique to subset B (60H to 7FH) without inputting a character code unique to subset A (00H to 1FH). (If a character code unique to subset A is input in this step, subset B is not selected. The character code unique to subset B input in step 1 is expressed with the shift code.)*
- *The following shows the transition conditions from subset B to subset A.*
 1. *Input a character code unique to subset A when subset B is selected.*
 2. *Then input a character code unique to subset A without inputting a character code unique to subset B. (If a character code unique to subset B is input in this step, subset A is not selected. The character code unique to subset A input in step 1 is expressed with the shift code.)*
- *Subset C is selected when four continuous character codes (30H to 39H) are input.*
- *If a code common to subset A and subset B is input when a subset is not determined or subset C is selected, subset B is selected temporarily selected.*

□ **UPC-E conversion rule**

- NSC, manufacturer's codes (M1 M2 M3 M4 M5), and product item codes (X1 X2 X3 X4 X5) are input data.

1. NSC must be 0 or 1.
2. When the manufacturer's code data is input, the rule is determined and zero checking of the product item codes is performed.
 NZ: Non-zero *: 0 to 9

UCP-A Type

	M1	M2	M3	M4	M5	X1	X2	X3	X4	X5
Rule 1	*	*	*	*	NZ	0	0	0	0	5~9
Rule 2	*	*	*	NZ	0	0	0	0	0	*
Rule 3	*	*	3~9	0	0	0	0	0	*	*
Rule 4	*	*	0~2	0	0	0	0	*	*	*

3. The following table shows print data if the rule shown above is met.

UCP-E Type

Rule 1	M1	M2	M3	M4	M5	X5 (5~9)
Rule 2	M1	M2	M3	M4	X5	'4'
Rule 3	M1	M2	M3	X4	X5	'3'
Rule 4	M1	M2	X3	X4	X5	M3 (0~2)

□ **Calculating the check character**

- Modulus 10
 - a. The data at the odd-numbered position counted from the right are weighed as 3. The sum of the data character values is determined.. (The sum is determined without weighing for Postnet.)
 - b. The remainder of dividing the value determined in step a by 10 is determined.
 - c. A character having a character value equal to the remainder of subtracting the value determined in step b from 10 is the check character.

- **Modulus 11**

- Data characters are weighed from the right to the left, as, example, 1, 2, ..., 10, 1, 2 ... 10, 1, 2 and so forth. The sum of the data character values is determined. (The symbol '-' has a character value of 10.)
- A character having a character value equal to the remainder of dividing the value determined in step a by 11 is the first check character (C).
- Data characters are weighed from the right to the left, beginning with C, as, for example, 1, 2, ..., 9, 1, 2 ... , 9, 1, 2 and so forth. The sum of the data character values is determined.
- The character with a character value equal to the remainder of dividing the value determined in step c by 11 is the second check character (K).

- **Modulus 16**

- The sum of the all characters including start and stop characters values is determined. The following table shows the conversion of character into value.

Value	Character	Value	Character	Value	Character	Value	Character
0	0	1	1	2	2	3	3
4	4	5	5	6	6	7	7
8	8	9	9	10	-	11	\$
12	:	13	/	14	.	15	+
16	A	17	B	18	C	19	D

- The remainder X of deviding the value determined in step a by 16 is determined. The remainder Y of subtracting the remainder X from 16 is determined.
- Convert the remainder Y into the character Z according to the conversion table in a. The character Z is the check character.

- **Modulus 43**

- The sum of the data character values is determined.
- The character with a character value equal to the remainder of dividing the value determined in step a by 43 is the check character.

- **Modulus 47**

- a. Data characters are weighed from the right to the left, as, for example, 1, 2, ..., 20, 1, 2 ... 20, 1, 2 and so forth. The sum of the data character values determined..
- b. The character with a character value equal to the remainder of dividing the value determined in step a by 47 is the first check character (C).
- c. Data characters are weighed from the right to the left, beginning with C, as, for example, 1, 2, ..., 15, 1, 2 ... , 15, 1, 2 and so forth. The sum of the data character values is determined.
- d. The character with a character value equal to the remainder of dividing the value found in step c by 47 is the second check character (K).

- **Modulus 103**

- a. The sum of the products of the data character values and position values is determined. (The leftmost character has a position value of 1.)
- b. The start character value is added to the sum determined in step a above.
- c. The character with a character value equal to the remainder of dividing the value determined in step c by 103 is the check character.

□ **Other**

- After executing a BS command input immediately after bar code data, printing starts from the position by one character to the left of the currently set character pitch.
- When a margin is specified, bar code data in the buffer is cleared.

□ **Element printing**

- The element printing function prints bar codes by inputting data element by element.
- This function allows the user to print bar codes which are not supported by the printer but are expressed by combining elements. No HRI is printed, no check digit is added, and a start or stop character is not added, since data is input element by element.
- The following show the codes expressing elements.
 - 00H: Narrow bar
 - 01H: Wide bar
 - 02H: Narrow space
 - 03H: Wide space
 - 04H: Inter-character gap

□ Element printing

[Example]

The following shows a BASIC program for printing Code 39 bar codes using the element printing function. This example shows how to print "CODE39". (Replace NB, WB, NS and WS in the data statements in the following example with 0, 1, 2 and 3, respectively.)

```

100 OPEN "LPT1:" AS #1: WIDTH #1,255
110 DC4$=CHR$ (&H14): ESC$=CHR$(&H1B)
120 SI$=CHR$(&HF):SO$=CHR$(&HE): ICG=4
130 '
140 PRINT #1, DC4$;DC4$;"@";           ' Initialize
150 PRINT #1, DC4$;DC4$;"T";CHR$(255); ' Barcode Type: Element Print
160 PRINT #1, DC4$;DC4$;"E";CHR$(0);CHR$(2); ' Narrow Bar: 2/120"
170 PRINT #1, DC4$;DC4$;"E";CHR$(1);CHR$(6); ' Wide Bar: 6/120"
180 PRINT #1, DC4$;DC4$;"E";CHR$(2);CHR$(2); ' Narrow Space: 2/120"
190 PRINT #1, DC4$;DC4$;"E";CHR$(3);CHR$(6); ' Wide Space: 6/120"
200 PRINT #1, DC4$;DC4$;"E";CHR$(4);CHR$(2); ' Inter Char Gap: 2/120"
210 PRINT #1, DC4$;DC4$;"H";CHR$(6);     ' Barcode Height: 6/12"
220 '
230 PRINT #1, DC4$;DC4$;"B";CHR$(9*8+7); ' Barcode Data Sequence Start
240 RESTORE 440
250 FOR I=1 TO 9:READ A:PRINT CHR$(A);:NEXT I
260 PRINT #1, CHR$(ICG);
270 FOR J=1 TO 6
280 IF J=1 THEN RESTORE 450
290 IF J=2 THEN RESTORE 460
300 IF J=3 THEN RESTORE 470
310 IF J=4 THEN RESTORE 480
320 IF J=5 THEN RESTORE 490
330 IF J=6 THEN RESTORE 500
340 FOR I=1 TO 9:READ A: PRINT #1, CHR$(A);:NEXT I
350 PRINT #1, CHR$(ICG);
360 NEXT J
370 RESTORE 440
380 FOR I=1 TO 9:READ A: PRINT #1, CHR$(A);:NEXT I
400 PRINT #1,CHR$(13);CHR$(10);         ' CR+LF
410 CLOSE #1
420 END
430 '
440 DATA 0, 3, 0, 2, 1, 2, 1, 2, 0
450 DATA 1, 2, 1, 2, 0, 3, 0, 2, 0
460 DATA 1, 2, 0, 2, 1, 2, 0, 3, 0
470 DATA 0, 2, 0, 2, 1, 3, 0, 2, 1
480 DATA 1, 2, 0, 2, 1, 3, 0, 2, 0
490 DATA 1, 2, 1, 3, 0, 2, 0, 2, 0
500 DATA 0, 2, 1, 3, 0, 2, 1, 2, 0

```

Enlarged character function

If #27 BARCODE/ENLARGED CHAR is set to MODE 1 or MODE 2 in the EXTENDED SETUP MODE, enlarged characters can be printed. The enlarged character function is valid for the EPSON or IBM or HP mode.

□ Outline of enlarged character function

When the enlarged character mode is selected with the DC4 DC4 l 1 command, any commands other than those shown below are ignored.

Only three print codes are available: LF, CR and FF. If 521 or more characters of data are sent without inputting a print command, printing is performed automatically.

□ Enlarged character command list

	Function	Command
1.	Executing backspacing	BS
2.	Executing line feeding	LF
3.	Executing form feeding	FF
4.	Executing carriage return	CR
5.	Initializing the enlarged character mode	DC4 DC4 @
6.	Arrangement of enlarged characters	DC4 DC4 a
7.	Element magnification for enlarged characters	DC4 DC4 c
8.	All-character set for enlarged characters	DC4 DC4 d
9.	Selecting an enlarged character font	DC4 DC4 f
10.	Height expansion for enlarged characters	DC4 DC4 h
11.	HMI for enlarged characters	DC4 DC4 i
12.	VMI for enlarged characters	DC4 DC4 j
13.	Setting and canceling the enlarged character mode	DC4 DC4 l
14.	Enlarged character cell offset	DC4 DC4 o
15.	Enlarged character pitch	DC4 DC4 p
16.	Enlarged character quality	DC4 DC4 q
17.	Enlarged character rotational angle	DC4 DC4 r
18.	Setting and canceling enlarged character smoothing	DC4 DC4 s
19.	Enlarged character top offset	DC4 DC4 t
20.	Setting and canceling underscores for enlarged characters	DC4 DC4 u
21.	Enlarged character width expansion	DC4 DC4 w
22.	Horizontal printing position for enlarged characters	DC4 DC4 x
23.	Vertical printing position for enlarged characters	DC4 DC4 y

(1) Executing backspacing: BS

Format:	ASCII	BS
	Hex	08
	Decimal	08

Function: Executes backspacing.

When the BS command is executed, the printing position moves to the previous character position on the left. The BS command is valid up to the left margin. A BS command issued on the left margin is ignored.

When a BS command is issued when there is a character on the left with proportional printing selected, the printer backspaces to that character. If there is no character or another BS command has just been executed, the printer backspaces by one space.

(2) Executing line feeding: LF

Format:	ASCII	LF
	Hex	0A
	Decimal	10

Function: Executes line feeding.

After printing data, the printer feeds one line by the enlarged character line feed pitch, which differs depending on whether VMI is valid (by the DC4 DC4 j command) or not.

VMI valid: Preset VMI amount

VMI not valid: $(24 + \text{cell offset})/180'' \times \text{cell expansion}$

Line feeding involves a carriage return if the LF SETTING option is set to LF + CR in the EXTENDED SETUP MODE.

If the bottom margin is specified and the cell size (i.e., $24/180'' \times \text{cell expansion}$) is greater than the printable area in the CSF, cut sheet, or fanfold paper mode, form feeding is executed and then printing is executed. If the printing position is at the TOF position, printing is executed up to the bottom margin without executing form feeding, and excess data is not printed.

The default pitch is $1/6'' \times \text{cell expansion}$.

(3) Executing form feeding: FF

Format:	ASCII	FF
	Hex	0C
	Decimal	12

Function: Executes form feeding.

This command feeds the page to the next TOF position. If there are still enlarged characters to be printed, they are printed, then form feeding is executed.

(4) Executing carriage return: CR

Format:	ASCII	CR
	Hex	0D
	Decimal	13

Function: Executes carriage return.

This command moves the printing position to the left margin without printing any characters. If the CR SETTING option is set to CR + LF in the EXTENDED SETUP MODE, a carriage return is executed out after printing.

(5) Initializing the enlarged character mode: DC4 DC4 @

Format:	ASCII	DC4	DC4	@
	Hex	14	14	40
	Decimal	20	20	64

Function: Initializes the enlarged character mode.

The following show the default settings for enlarged characters:

Cell expansion:	SETUP expansion
Height expansion:	SETUP expansion
Width expansion:	SETUP expansion
Font:	SETUP font
Character pitch:	10 cpi
HMI:	Invalid
Cell offset:	6/180°
VMI:	Invalid
Character quality:	Standard
Character layout:	Adjusted to the base line
Rotational angle:	0°
Smoothing:	Valid
Top offset:	0/180°
Underscore:	Canceled
Character set:	Enlarged character mode selected
Right and left margins:	Enlarged character mode selected
Page length:	Enlarged character mode selected
Top and bottom margins:	Enlarged character mode selecte

(6) Arrangement of enlarged characters: DC4 DC4 a

Format:	ASCII	DC4	DC4	a	n
	Hex	14	14	61	n
	Decimal	20	20	97	n

Function: Specifies the standard position for adjusting enlarged characters in the vertical direction.

n = 00H, 30H: Base line is adjusted to the N'th dot from the top.
(N = 20 x cell expansion)

01H, 31H: Descender is adjusted to the N'th dot from the top.
(N = 24 x cell expansion)

02H, 32H: Center is adjusted to the N'th dot from the top.
(N = 12 x cell expansion)

03H, 33H: Ascender is adjusted to the N'th dot from the top.
(N = 1 x cell expansion)

The MSB of the parameter is masked. Any parameters other than those shown above are ignored.

The arrangement and position specified here are valid if the enlarged character rotational angle is not 0 degree. The default setting is n = 00H,30H.

(7) Cell expansion for enlarged characters: DC4 DC4 c

Format:	ASCII	DC4	DC4	c	n
	Hex	14	14	63	n
	Decimal	20	20	99	n

Function: Specifies cell expansion for enlarged characters.

$$0 \leq n \leq 127$$

The cell has the size of (24/180" x cell magnification). The MSB of the parameter is masked.

If n = 0, the expansion specified in the setup mode is selected.

The cell expansion is specified at the beginning of the line. If there is character data on the line, it becomes valid on the following line.

Enlarged character cell expansion takes priority over the height expansion.

If the height expansion exceeds cell expansion when enlarged character data is input, the characters are enlarged to the cell expansion value.

The default setting is the expansion specified in the setup mode.

(8) All-character set for enlarged characters: DC4 DC4 d

Format:	ASCII	DC4	DC4	d	n	d1	d2...dn
	Hex	14	14	64	n	d1	d2...dh
	Decimal	20	20	100	n	d1	d2...dn

Function: Specifies the all-character set for enlarged characters.

$$1 \leq n \leq 255$$

$$0 \leq d \leq 255$$

Data with a number specified with the parameter “n” is processed as character codes. If n = 0, this sequence is ignored.

(9) Selecting an enlarged character font: DC4 DC4 f

Format:	ASCII	DC4	DC4	f	n
	Hex	14	14	66	n
	Decimal	20	20	102	n

Function: Specifies the font (typeface) of enlarged characters as shown below.

- n = 0: Roman
- 1: Sans Serif
- 2: Courier
- 3: Prestige
- 4: Script
- 5: OCR-B
- 6: OCR-A
- 7: Gothic
- 8: Orator
- 9: Orator-S

The MSB of the parameter is masked. Any parameters other than those shown above are ignored.

If the FONT LOCK option is set to YES in the EXTENDED SETUP MODE, this command is ignored.

The default is the setting selected in the setup mode.

(10) Height expansion for enlarged characters: DC4 DC4 h

Format:	ASCII	DC4	DC4	h	n
	Hex	14	14	68	n
	Decimal	20	20	104	n

Function: Specifies the height expansion of enlarged characters.

$$0 \leq n \leq 127$$

The MSB of the parameter is masked.

If $n = 0$, the expansion specified in the setup mode is selected.

Enlarged character cell expansion takes priority over height expansion. If the height expansion exceeds the cell expansion when enlarged character data is input, the characters are enlarged to the cell expansion.

The default setting is the expansion specified in the setup mode.

(11) HMI for enlarged characters: DC4 DC4 i

Format:	ASCII	DC4	DC4	i	n1	n2
	Hex	14	14	69	n1	n2
	Decimal	20	20	105	n1	n2

Function: Specifies the HMI (horizontal motion index) of enlarged characters.

$$0 \leq n1 \leq 255$$

$$0 \leq n2 \leq 15$$

The HMI indicates the horizontal distance between two adjacent characters, i.e., the width the print head moves after printing one character.

The HMI is $(n1 + n2 \times 256)/180$ ".

The high-order four bits of parameter $n2$ (bit 7 to bit 4) are ignored. The HMI can be set to zero.

After specified command have priority over DC4 DC4 p or DC4 DC4 i.

If the PITCH LOCK option is set to YES in the setup mode, this command is ignored.

The default setting is "10 cpi x widthwise expansion".

(12) VMI for enlarged characters: DC4 DC4 j

Format:	ASCII	DC4	DC4	j	n1	n2
	Hex	14	14	6A	n1	n2
	Decimal	20	20	106	n1	n2

Function: Specifies the VMI (vertical motion index) of enlarged characters.

$$0 \leq n1 \leq 255$$

$$0 \leq n2 \leq 127$$

The VMI indicates the distance between two lines, i.e., the length the print head moves after printing one line.

The VMI is $(n1 + n2 \times 256)/180''$. The MSB of parameter n2 is masked.

The VMI can be set to zero.

The VMI is not dependent on the length expansion of enlarged characters.

After specified command have priority over DC4 DC4 j or DC4 DC4 o.

The VMI is invalid and the cell offset 6 line feed pitch is selected (i.e., 1/6" x cell expansion) by default.

(13) Setting and canceling the enlarged character mode: DC4 DC4 l

Format:	ASCII	DC4	DC4	l	n
	Hex	14	14	6C	n
	Decimal	20	20	108	n

Function: Sets and cancels the enlarged character mode.

n = 00H, 30H: Cancels the enlarged character mode.

01H, 31H: Sets the enlarged character mode.

The MSB of the parameter is masked. Any sequences other than the above parameters are ignored.

When the enlarged character mode establish command is issued, the special effects, character pitch, line feed pitch, length and width double-size printing settings specified for the emulation become invalid the enlarged character mode is canceled.

When the enlarged character mode starts, characters are printed in the conditions selected when the enlarged character mode was last canceled.

If there are non-enlarged characters or bar codes when enlarge character data is input the non-enlarged character are printed.

In the enlarged character mode, automatic printing is not performed if the printing position exceeds the right margin. Excess data is abandoned and the printing position is set at the right margin when the right margin is exceeded.

If the right margin is exceeded while a single enlarged character is being printed, the character is printed up to the right margin.

(14) Enlarged character cell offset: DC4 DC4 o

Format:	ASCII	DC4	DC4	o	n
	Hex	14	14	6F	n
	Decimal	20	20	111	n

Function: Specifies the cell offset for enlarged characters.

$$0 \leq n \leq 255$$

This command specifies the cell offset for the enlarged characters in 1/180". The cell offset is used to execute a line feed (LF) command.

In the enlarged character mode, the line is fed by a pitch of (24 + cell offset)/180" x cell expansion.

The VMI is invalid and the cell offset is 6 by default.

(15) Enlarged character pitch: DC4 DC4 p

Format:	ASCII	DC4	DC4	p	n
	Hex	14	14	70	n
	Decimal	20	20	112	n

Function: Specifies the pitch of enlarged characters.

n = 00H, 30H: 10 cpi

01H, 31H: 12 cpi

02H, 32H: Proportional

The MSB of the parameter is masked. Any sequences other than the above parameters are ignored.

If the fixed pitch is selected, enlarged characters have the following width:

10 cpi: (18 x 180") x widthwise expansion

12 cpi: (15 x 180") x widthwise expansion

In the proportional mode, proportional characters are expanded by the same ratio.

When the rotational angle for enlarged characters is set to 90 or 270 degrees, characters other than graphic character are printed at a pitch of (24/180") x length expansion. If the PITCH LOCK option is set to YES in the setup mode, this command is ignored.

The HMI is invalidated and the character pitch is 10 cpi by default.

(16) Enlarged character quality: DC4 DC4 q

Format:	ASCII	DC4	DC4	q	n
	Hex	14	14	71	n
	Decimal	20	20	113	n

Function: Specifies the quality of enlarged characters as shown below.

n = 00H, 30H:	Standard quality
01H, 31H:	High-speed 1 quality
02H, 32H:	High-speed 2 quality

The MSB of the parameter is masked. Any sequences other than the above parameters are ignored.

The character quality is specified at the beginning of a line. If there is character data on the line, this command is reserved and becomes valid on the following line.

If the QUALITY LOCK option is set to YES in the setup mode, this command is ignored.

The standard quality is selected by default.

(17) Enlarged character rotational angle: DC4 DC4 r

Format:	ASCII	DC4	DC4	r	n
	Hex	14	14	72	n
	Decimal	20	20	114	n

Function: Specifies the rotational angle of enlarged characters as shown below.

n = 00H, 30H	0°
01H, 31H	90°
02H, 32H	180°
03H, 33H	270°

Enlarged characters are rotated counterclockwise.

The MSB of the parameter is masked. Any sequences other than the above parameters are ignored.

Printing starts from the position specified with the DC4 DC4 a command shown above.

Unless the rotational angle is set to 0 degree, no characters are underscored even when underscores are input.

Pixels are printed at a rotational angle of 0 degree even if the rotational angle is set to 90, 180, or 270 degrees.

This command is ignored if the PITCH LOCK option is set to YES in the EXTENDED SETUP MODE and the length and width expansion values of enlarged characters are different.

The default rotational angle is 0 degree.

(18) Setting and canceling enlarged character smoothing: DC4 DC4 s

Format:	ASCII	DC4	DC4	s	n
	Hex	14	14	73	n
	Decimal	20	20	115	n

Function: Sets and cancels smoothing of enlarged characters.

n = 00H, 30H: Cancels smoothing.

01H, 31H: Sets smoothing.

The MSB of the parameter is masked. Any sequences other than the above parameters are ignored.

Smoothing is set by default.

(19) Enlarged character top offset: DC4 DC4 t

Format:	ASCII	DC4	DC4	t	m	n1	n2
	Hex	14	14	74	m	n1	n2
	Decimal	20	20	116	m	n1	n2

Function: Specifies the top offset of enlarged characters.

m = (20)H

$0 \leq n1 \leq 255$

$0 \leq n2 \leq 15$

The top offset refers to the vertical distance between the top of the cell and the top of a character. This determines the character position in the cell.

It is specified by $(n1 + n2 \times 256)/180$ ".

The high-order four bits of parameter n2 (bit 7 to bit 4) are masked.

The top offset is effective for only one character after this sequence.

The top offset is canceled when a line feed (LF) command, form feed (FF) command, or vertical print position (DC4 DC4 y) command is issued.

The top offset is not dependent on the enlarged character arrangement.

It is always based on the top of the cell (corresponding to the ascender-based position).

The top offset is not dependent on cell expansion or length expansion.

The bottom of a character (i.e., 24th pin position, regardless of character type, even for a 30-dot pixel) does not extend beyond the bottom of the cell. If the top offset is too large and the bottom of the character extends below the bottom of the cell, the top offset is reduced.

Any sequences other than m = 20H are ignored.

(20) Setting and canceling underscores for enlarged characters: DC4 DC4 u

Format:	ASCII	DC4	DC4	u	n
	Hex	14	14	75	n
	Decimal	20	20	117	n

Function: Sets and cancels the underscore function.
 n = 00H, 30H: Cancels underscoring.
 01H, 31H: Specifies the underscoring.

The MSB of the parameter is masked. Any sequences other than the above parameters are ignored.

An underscore is drawn on the 25th pin line at a thickness of (1 dot x length expansion of the character).

No underscores are printed if the enlarged character rotational angle is not set to 0 degree. Underscoring is off by default.

(21) Enlarged character width expansion: DC4 DC4 w

Format:	ASCII	DC4	DC4	w	n
	Hex	14	14	77	n
	Decimal	20	20	119	n

Function: Specifies the width expansion of enlarged characters.
 $0 \leq n \leq 127$

The MSB of the parameter is masked.

If n is set to 0, the magnification specified in the setup mode is selected. This command is ignored if the PITCH LOCK option is set to YES in the EXTENDED SETUP MODE.

The expansion specified in the setup mode is set by default.

(22) Horizontal printing position for enlarged characters: DC4 DC4 x

Format:	ASCII	DC4	DC4	x	m	n1	n2
	Hex	14	14	78	m	n1	n2
	Decimal	20	20	120	m	n1	n2

Function: Specifies the horizontal position for printing enlarged characters by $(n1 + n2 \times 256)/180''$ as shown below.

m = SP(20)H: Absolute printing position
 -(2D)H: Relative lefthand printing position
 +(2B)H: Relative righthand printing position
 $0 \leq n1 \leq 255$
 $0 \leq n2 \leq 15$

The MSB of parameter m and the four high-order bits of n2 (bit 7 to bit 4) are masked.

If parameter m is different than shown above, this sequence is ignored.

The absolute print position is based on the left margin. If the specified position exceeds the right margin, the print position is located at the right margin.

If a relative lefthand printing position to the left of the left margin is specified, left margin becomes the printing position.

If a relative righthand printing position to the right of the right margin is specified, the right margin becomes the printing position.

The movement distance is not dependent on the width expansion of enlarged characters.

(23) Vertical printing position for enlarged characters: DC4 DC4 y

Format:	ASCII	DC4	DC4	y	m	n1	n2
	Hex	14	14	79	m	n1	n2
	Decimal	20	20	121	m	n1	n2

Function: Specifies the vertical position for printing enlarged characters by $(n1 + n2 \times 256)/180''$ as shown below.

m = SP(20)H: Absolute printing position

-(2D)H: Relative reverse printing position

+(2B)H: Relative forward printing position

$0 \leq n1 \leq 255$

$0 \leq n2 \leq 127$

The MSBs of parameters m and n2 are masked. If parameter m is other than shown above, this sequence is ignored.

The absolute print position is based on the TOF position. If the specified position extends below the bottom margin, the bottom margin becomes the print position.

If a relative reverse printing position exceeding the TOF position is specified, the TOF position becomes the print position.

If a relative forward printing position that extends below the bottom margin is specified, the print position is located at the bottom margin.

The movement distance is not dependent on the length expansion of enlarged characters.

□ **Enlarged character print samples**

This page shows examples of a BASIC program for printing enlarged characters and the printed enlarged characters (actual size).

```

100 OPEN "LPT1:"AS #1
110 DC4$=CHR$(&H14)
120 '
130 PRINT #1, DC4$;DC4$;"@";           ' Initializing
140 PRINT #1,DC4$;DC4$;"c";CHR$(8);   ' Magnification of cell: x8
150 PRINT #1,DC4$;DC4$;"f";CHR$(4);   ' Font typeface: SCRIPT
160 PRINT #1,DC4$;DC4$;"p";CHR$(1);   ' Character pitch: 12 CPI
170 PRINT #1,DC4$;DC4$;"!";CHR$(1);   ' Magnification mode on
180 '
190 PRINT #1,"8";                       ' Default size print
200 PRINT #1,DC4$;DC4$;"h";CHR$(2);   ' Vertical magnification: x2
210 PRINT #1,DC4$;DC4$;"w";CHR$(2);   ' Horizontal magnification: x2
220 PRINT #1,DC4$;DC4$;"a";CHR$(3);   ' Alignment: ascender
230 PRINT #1,"ASCE";
240 PRINT #1,DC4$;DC4$;"a";CHR$(2);   ' Alignment: center
250 PRINT #1,"CENT";
260 PRINT #1,DC4$;DC4$;"a";CHR$(1);   ' Alignment: descender
270 PRINT #1,"DESC";
280 PRINT #1,DC4$;DC4$;"a";CHR$(0);   ' Alignment: baseline
290 PRINT #1,"BASE";
300 '
310 PRINT #1,DC4$;DC4$;"w";CHR$(8);   ' Horizontal magnification: x8
320 PRINT #1,"H";
330 PRINT #1,DC4$;DC4$;"w";CHR$(1);   ' Horizontal magnification: x1
340 FOR N=1 TO 8
350 PRINT #1,DC4$;DC4$;"h";CHR$(N);   ' Vertical magnification: xn
360 PRINT #1,RIGHT$(STR$(N),1); '
370 NEXT N
380 PRINT #1,DC4$;DC4$;"w";CHR$(8);   ' Horizontal magnification: x8
390 PRINT #1,DC4$;DC4$;"r";CHR$(1);   ' Rotate: 90 degree
400 PRINT #1, "R" ;
410 PRINT #1,CHR$(13);CHR$(10); ' CR+LF
420 '
430 PRINT #1,DC4$;DC4$;"!";CHR$(0);   ' Magnification mode off
440 CLOSE #1
450 END

```

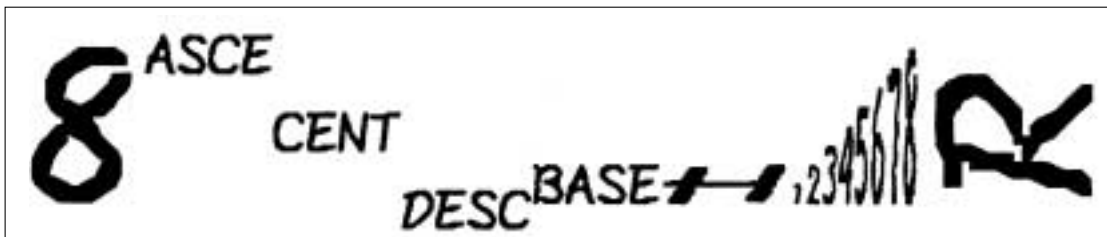

Appendix A. Specifications

□ Printing specifications

Printing method	<ul style="list-style-type: none"> Impact dot matrix and bidirectional logic seeking printing
Print Head	<ul style="list-style-type: none"> 24 pins, movable-type (parallel/staggered orientation.) Estimated life expectancy: 500 million dots/wire
Emulation	<ul style="list-style-type: none"> Hewlett Packard RuggedWriter 480 Epson LQ-2550 IBM 2391
Resident fonts	<ul style="list-style-type: none"> Draft, High quality draft, Speed draft, Super speed draft Roman, Sans Serif, Courier, Prestige, Script, OCR-B, OCR-A, Gothic, Orator, Orator-S
Down load character sets	<ul style="list-style-type: none"> HP character sets (up to 256 characters (32kB) downloadable) Epson character sets (up to 128 characters downloadable) IBM character sets and code pages (32kB download area)
Graphic printing	<p>Raster Graphics Printing (HP)</p> <p>4 Categories: dpi: dot per inch</p> <ul style="list-style-type: none"> 60 dpi (60h X 60v dpi), raster graphic mode 90 dpi (90h X 90v dpi), raster graphic mode 180 dpi (180h X 180v dpi), raster graphic mode 360 dpi (360h X 360v dpi), raster graphic mode <p>Bit Image Printing (EPSON/IBM)</p> <p>11 Categories (8 or 24 pin graphics):</p> <ul style="list-style-type: none"> 60 dpi 80 dpi — 8-pin only 90 dpi 120 dp — 8-pin only 120 dpi * 180 dpi — 24-pin only 240 dpi — 8-pin only * 360 dpi — 24-pin only * 360 dpi — 48-pin only (IBM mode) * <p>* Horizontally adjacent dots can not be printed.</p>
Print mode	<p>Character spacings</p> <ul style="list-style-type: none"> 10 cpi Pica print mode 12 cpi Elite, Speed draft print mode 15 cpi Super speed draft print mode 16.7 cpi Condensed print mode 17.1 cpi Condensed pica print mode 20 cpi Condensed elite print mode 24 cpi print mode Proportional print mode One half proportional print mode

Character table (HP mode)	<p>Character Tables in the HP mode</p> <ul style="list-style-type: none"> • ROMAN-8 (8U) • PC-8 (10U) • PC-850 (12U) • ECMA 94 • LATIN1 (ISO 8859-1 , 0N) • PC-8 DENMARK/NORWAY (11U) • LINE-DRAW (0L,0B) • MATH-7 (0A, 0M) • ROMAN-EXTENSION (0E) • SWEDEN 1 (ISO-10, 0S) • SWEDEN 2 (ISO-11, 3S) • NORWAY 1 (ISO-60, 0D) • NORWAY 2 (ISO-61, 1D) • UK (ISO-4, 1E) • FRANCE 2 (ISO-25, 0F) • FRANCE 1 (ISO-69, 1F) • GERMAN 2 (0G) • GERMAN 1 (ISO-21, 1G) • ITALY (ISO-15, 0I) • SPAIN 3 (1S) • SPAIN 1 (ISO-17, 2S) • SPAIN 2 (ISO-85, 6S) • PORTUGAL 1 (ISO-16, 4S) • PORTUGAL 2 (ISO-84, 5S) • IRV (ISO-2, 2U) • JAPAN (ISO-14, 0K) • ASCII (ISO-6, 0U) • LEGAL (1U) 																		
(EPSON mode)	<p>Character Tables in the EPSON mode</p> <ul style="list-style-type: none"> • Italic character table • Graphic character table • Graphic character table, extended 																		
(IBM mode)	<p>Character Tables in the IBM mode</p> <ul style="list-style-type: none"> • IBM character set 1 table • IBM character set 2 table • IBM all character set table 																		
International character set (EPSON mode)	<p>USA, FRANCE, GERMANY, U.K., DENMARK, SWEDEN, ITALY, SPAIN, JAPAN, NORWAY, DENMARK2, SPAIN2, LATIN-AMERICAN, KOREA, TURKEY, LEGAL</p>																		
Codepage Character table (HP, EPSON, IBM mode)	<p>437(USA), 850(MULTILINGUAL), 857(TURKEY), 858, 860(PORTUGUESE), 861, 863(CANADA-FRENCH), 865 (NORDIC), BRASCII, ABICOMP, ISO-8859-1</p>																		
Barcode type (HP, EPSON, IBM mode)	<p>Industrial 2 of 5, Interleaved 2 of 5, Matrix 2 of 5, Codabar, Code 11, Code 39, Code 93, Code 128, EAN 8, EAN 13, UPC-A, UPC-E, and Postnet.</p>																		
Throughput	<table border="0"> <tr> <td>• Draft (10cpi) :</td> <td>198 lpm</td> <td>186 lpm</td> </tr> <tr> <td>• HQDR (10cpi) :</td> <td>138 lpm</td> <td>127 lpm</td> </tr> <tr> <td>• NLQ (10cpi) :</td> <td>99 lpm</td> <td>92 lpm</td> </tr> <tr> <td>• LQ (10cpi) :</td> <td>76 lpm</td> <td>71 lpm</td> </tr> <tr> <td>• Speed draft (Elite) :</td> <td>228 lpm</td> <td>213 lpm</td> </tr> <tr> <td>• Super speed draft :</td> <td>268 lpm</td> <td>246 lpm</td> </tr> </table>	• Draft (10cpi) :	198 lpm	186 lpm	• HQDR (10cpi) :	138 lpm	127 lpm	• NLQ (10cpi) :	99 lpm	92 lpm	• LQ (10cpi) :	76 lpm	71 lpm	• Speed draft (Elite) :	228 lpm	213 lpm	• Super speed draft :	268 lpm	246 lpm
• Draft (10cpi) :	198 lpm	186 lpm																	
• HQDR (10cpi) :	138 lpm	127 lpm																	
• NLQ (10cpi) :	99 lpm	92 lpm																	
• LQ (10cpi) :	76 lpm	71 lpm																	
• Speed draft (Elite) :	228 lpm	213 lpm																	
• Super speed draft :	268 lpm	246 lpm																	

Throughput

Evaluation conditions:
 Data of 100 lines by 132 columns, all ASCII rolling pattern characters, and 1/6-inch line feed is input from a host and is stored in the 64K-byte communication buffer of the printer. With that condition, the number of printing lines per minute is measured.

<p>Paper feed method Paper width Paper weight</p>	<p>Friction method:</p> <ul style="list-style-type: none"> • Single cut sheet (A3, B4, A4, B5, letter, legal) • 55 kg - 90 kg in Japan • 17 lbs. - 28 lbs. in USA • 64 g/m² - 105 g/m² in Europe <p>Tractor method:</p> <ul style="list-style-type: none"> • 45 kg - 90 kg in Japan • 14 lbs. - 28 lbs. in USA • 53 g/m² - 105 g/m² in Europe <p>CSF mode (option):</p> <ul style="list-style-type: none"> • 55 kg - 70 kg in Japan • 15 lbs. - 21 lbs. in USA • 60 g/m² - 81 g/m² in Europe
<p>Label paper</p>	<ul style="list-style-type: none"> • Paper stiffness of less than 125 kg or equivalent • Total thickness of less than 0.18 mm
<p>Multiple copies</p>	<ul style="list-style-type: none"> • Original plus 8, non-carbon, 34 Kg or equivalent • Total thickness of less than 0.59 mm
<p>Line feed pitch</p>	<ul style="list-style-type: none"> • Minimum of 1/360 inch
<p>Line feed speed</p>	<ul style="list-style-type: none"> • 60 lines/second (6 lines/inch)
<p>Print speed</p>	<ul style="list-style-type: none"> • Super Speed Draft (15 cpi): 846 cps (character per second) • Speed Draft (12 cpi): 674 cps • Draft Pica (10 cpi): 564 cps • HQDR Pica (10 cpi): 360 cps • NLQ Pica (10 cpi): 240 cps • LQ Pica (10 cpi): 180 cps

Recommended print area

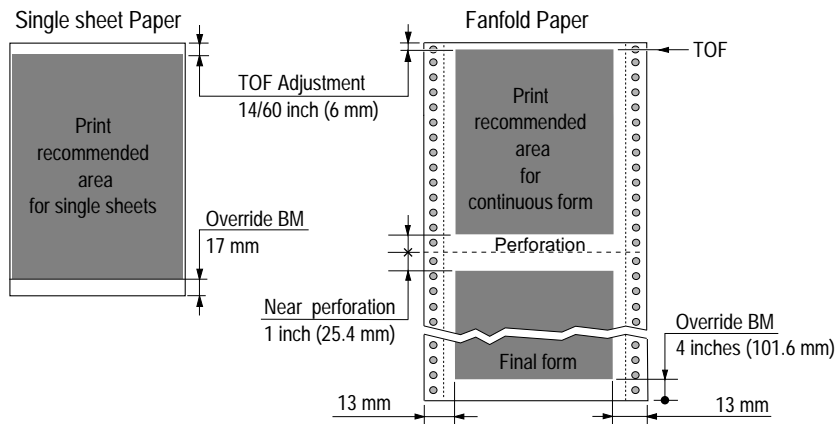

Print mode specifications

Note: (+n) indicates the number of space added.

Print mode		Multipart mode	Dot Spacing (inches)	Max No. of Columns	Character Structure (V X H)	Printing Speed (cps)
Draft	10 cpi	Normal Dark 1 Dark 2	1/90 X 1/120 1/90 X 1/120 1/90 X 1/180	136	12 x 12 12 x 12 12 x 18	564 473 315
	12 cpi	Normal Dark 1 & 2	1/90 X 1/144	163	12 x 12	569 432
	15 cpi	Normal Dark 1 & 2	1/90 X 1/180	204	12 x 12	712 473
	16.7 cpi	Normal Dark 1 & 2	1/90 X 1/240	227	12 x 12(+2.4)	526 394
	17 cpi	Normal Dark 1 & 2	1/90 X 1/240	233	12 x 12(+2)	540 411
	20 cpi	Normal Dark 1 & 2	1/90 X 1/240	272	12 x 12	631 481
	24 cpi	Normal Dark 1 & 2	1/90 X 1/360	326	12 x 12(+3)	577 378
	Proportional	Normal Dark 1 & 2	1/90 X 1/144	----	12 x N	----
	1/2 Proportional	Normal Dark 1 & 2	1/90 X 1/360	----	12 x N	----
Speed Draft	12 cpi	Normal Dark 1 & 2	1/90 X 1/120	163	12 x 8(+2)	676 568
S.Speed Draft	15 cpi	Normal Dark 1 & 2	1/90 X 1/120	204	12 x 8	846 710
	10 cpi	Normal Dark 1 & 2	1/180 X 1/120	136	24 x 12	360 240
HQDR	12 cpi	Normal Dark 1 & 2	1/180 X 1/144	163	24 x 12	289 216
	15 cpi	Normal Dark 1 & 2	1/180 X 1/180	204	24 x 12	360 236
	16.7 cpi	Normal Dark 1 & 2	1/180 X 1/240	227	24 x 12(+2.3)	263 175
	17 cpi	Normal Dark 1 & 2	1/180 X 1/240	233	24 x 12(+2)	270 180
	20 cpi	Normal Dark 1 & 2	1/180 X 1/240	272	24 x 12	316 210
	24 cpi	Normal Dark 1 & 2	1/180 X 1/360	326	24 x 12(+3)	379 253
	Proportional	Normal Dark 1 & 2	1/180 X 1/144	----	24 x N	----
	1/2 Proportional	Normal Dark 1 & 2	1/180 X 1/360	----	24 x N	----
Near Letter Quality	10 cpi	Normal Dark 1 & 2	1/180 X 1/360	136	24 x 36	240 158
	12 cpi	Normal Dark 1 & 2	1/180 X 1/360	163	24 x 30	289 189
	15 cpi (EPSON)	Normal Dark 1 & 2	1/180 X 1/360	204	16 x 24	361 237
	15 cpi (HP/IBM)	Normal Dark 1 & 2	1/180 X 1/720	204	24 x 36(+12)	237 158
	16.7 cpi	Normal Dark 1 & 2	1/180 X 1/720	227	24 x 36(+7)	263 175
	17 cpi	Normal Dark 1 & 2	1/180 X 1/720	233	24 x 36(+6)	270 180
	20 cpi	Normal Dark 1 & 2	1/180 X 1/720	272	24 x 30(+6)	316 210
	24 cpi (EPSON)	Normal Dark 1 & 2	1/180 X 1/720	326	16 x 24(+6)	379 253
	24 cpi (HP/IBM)	Normal Dark 1 & 2	1/180 X 1/720	326	24 x 30	379 253
	Proportional	Normal Dark 1 & 2	1/180 X 1/360	----	24 x N	----
	1/2 Proportional	Normal Dark 1 & 2	1/180 X 1/720	----	24 x N	----

Note: (+n) indicates the number of space added.

Print mode		Multipart mode	Dot Spacing (V X H)	Max No. of Columns	Character Structure (V X H)	Printing Speed (cps)
Letter Quality	10 cpi	Normal Dark 1 Dark 2	1/180 X 1/360	136	24 x 36	180 79 59
	12 cpi	Normal Dark 1 Dark 2	1/180 X 1/360	163	24 x 30	216 95 71
	15 cpi (EPSON)	Normal Dark 1 Dark 2	1/180 X 1/360	204	16 x 24	270 118 86
	15 cpi (HP/IBM)	Normal Dark 1 Dark 2	1/180 X 1/720	204	24 x 36(+12)	237 118 89
	16.7 cpi	Normal Dark 1 Dark 2	1/180 X 1/720	227	24 x 36(+7)	263 131 98
	17 cpi	Normal Dark 1 Dark 2	1/180 X 1/720	233	24 x 36(+6)	270 135 102
	20 cpi	Normal Dark 1 Dark 2	1/180 X 1/720	272	24 x 30(+6)	315 158 119
	24 cpi (EPSON)	Normal Dark 1 Dark 2	1/180 X 1/720	326	16 x 24(+6)	380 189 142
	24 cpi (HP/IBM)	Normal Dark 1 Dark 2	1/180 X 1/720	326	24 x 24(+6)	380 189 142
	Proportional	Normal Dark 1 Dark 2	1/180 X 1/360	----	24 x N	----
	1/2 Proportional	Normal Dark 1 Dark 2	1/180 X 1/720	----	24 x N	----

Graphic Print Specifications

Graphic type		Horizontal dot pitch	Multipart mode	Print speed (inch / second)			
Density	Pins			MODE 1	MODE 2	MODE 3/High speed 1	High speed 2
60dpi	8/24	1/60 inch	Normal	31.5	31.5	31.5	31.5
			Dark 1/2	24.0	24.0	24.0	24.0
80dpi	8	1/80 inch	Normal	24.0	24.0	24.0	24.0
			Dark 1/2	18.0	18.0	18.0	18.0
90dpi	8/24	1/90 inch	Normal	18.0	18.0	18.0	18.0
			Dark 1/2	15.7	15.7	15.7	15.7
120dpi	8	1/60 inch	Normal	31.5	31.5	31.5	31.5
			Dark 1/2	24.0	24.0	24.0	24.0
120dpi	8/24	1/120 inch	Normal	15.7	18.0	31.5	36.0
			Dark 1/2	10.5	10.5	24.0	24.0
180dpi	24	1/180 inch	Normal	10.5	18.0	24.0	36.0
			Dark 1/2	7.9	10.5	18.0	24.0
240dpi	8	1/120 inch	Normal	15.7	18.0	31.5	36.0
			Dark 1/2	10.5	10.5	24.0	24.0
360dpi	24	1/180 inch	Normal	10.5	18.0	24.0	36.0
			Dark 1/2	7.9	10.5	18.0	24.0

MODE 1, 2 or 3 is set by "31 GRAPHIC QUALITY".

High speed 1 or 2 is set by the **QUALITY** key or "23 QUALITY".

□ Parallel interface specifications

- Input connector (36-pin parallel)

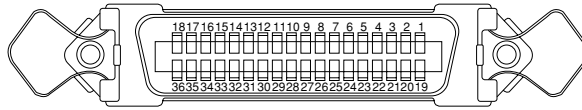

PIN	SIGNAL	IN/OUT	PIN	SIGNAL	IN/OUT
1	STROBE	IN	19	GND	
2	DATA 1	IN	20	GND	
3	DATA 2	IN	21	GND	
4	DATA 3	IN	22	GND	
5	DATA 4	IN	23	GND	
6	DATA 5	IN	24	GND	
7	DATA 6	IN	25	GND	
8	DATA 7	IN	26	GND	
9	DATA 8	IN	27	GND	
10	ACK	OUT	28	GND	
11	BUSY	OUT	29	GND	
12	PE	OUT	30	HIGH	
13	SELECT	OUT	31	INITIAL	IN
14	AUTOFEED	IN	32	ERROR	OUT
15	HIGH		33	HIGH	
16	LOW		34	NC	
17	CHASSIS GND		35	HIGH	
18	HIGH		36	SELECT IN	IN

- Notes:**
1. HIGH is pulled up to + 5V by 2.2k Ω resistor.
 2. LOW is pulled down to GND by 2.2k Ω resistor.
 3. NC stands for no connection.
 4. CHASSIS GND and GND are connected in the printer.
 5. SELECT IN signal is HIGH to accept a control code.

- Data input timing chart and input condition

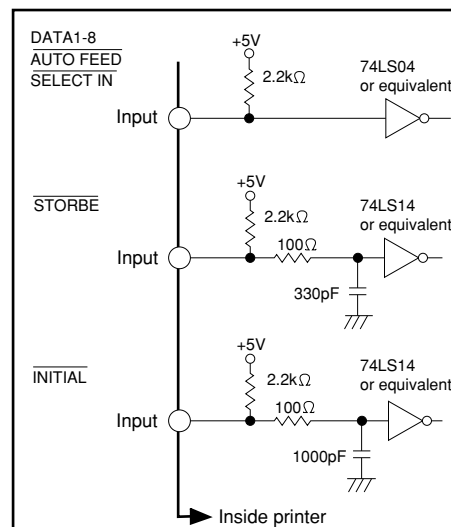
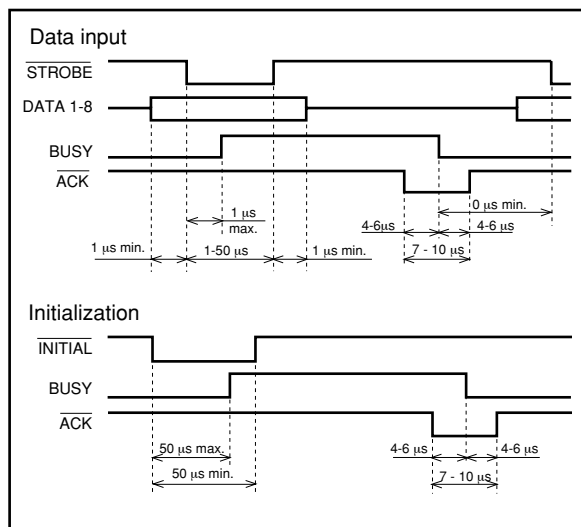

Serial interface specifications

Input connector (25-pin serial)

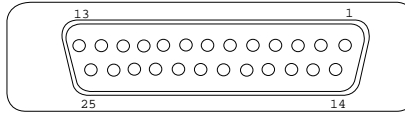

RS-232C Pin assignments

PIN	SIGNAL	IN/OUT	PIN	SIGNAL	IN/OUT
1	CHASSIS GND		14	NC	
2	TXD	OUT	15	NC	
3	RXD	IN	16	NC	
4	RTS	OUT	17	NC	
5	CTS	IN	18	NC	
6	DSR	IN	19	NC	
7	SIGNAL GND		20	DTR	OUT
8	CD	IN	21	NC	
9	NC		22	NC	
10	NC		23	NC	
11	SRTS	OUT	24	NC	
12	NC		25	INC	
13	NC				

- Notes:**
1. NC stands for no connection.
 2. CHASSIS GND and GND are connected in the printer.

Handshake protocol

One of the following four protocols can be selected:

- DTR protocol (Busy/Ready protocol)
- X ON/X OFF protocol I
- X ON/X OFF protocol II
- ETX/ACK protocol

Logic level

ON=Space (0)=High:
12V (+3 through +15V)
OFF=Mark (1)=LOW:
-12V (-3 through -15V)

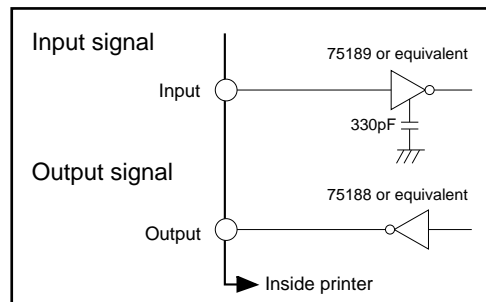

Baud Rate

In the setup options, one of the following baud rates can be selected:
300, 600, 1200, 2400, 4800, 9600, 19200, and 38400 BPS.

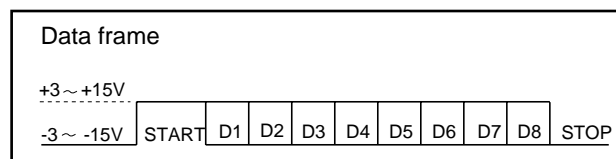

□ **Other specifications**

Buffer size	<ul style="list-style-type: none"> 64k byte, 8k byte, 128 byte (Changeable buffer size from the setup #71)
Cooling fan	<ul style="list-style-type: none"> 2 levels of fan speed control capability
Power supply	<ul style="list-style-type: none"> 120VAC: For USA and Canada 220 - 240VAC: For Australia, Asia, Europe and Others
Temperature	<ul style="list-style-type: none"> 41°F - 104°F (during Operation) 5°C - 40°C
Humidity	<ul style="list-style-type: none"> 20 % - 80 % (no condensation)
External dimensions	<p>[Model A]</p> <ul style="list-style-type: none"> 24.4"(Width) x 10.2"(Height) x 12.0"(Depth) 620(W) x 260(H) x 305(D) mm With the paper rack and sound seal cover 24.4"(W) x 11.6"(H) x 17.9"(D) 620(W) x 295(H) x 455(D) mm <p>[Model B]</p> <ul style="list-style-type: none"> 24.4"(Width) x 10.2"(Height) x 13.0"(Depth) 620(W) x 260(H) x 330(D) mm With the paper rack and sound seal cover 24.4"(W) x 11.6"(H) x 18.9"(D) 620(W) x 295(H) x 480(D) mm
Weight	<ul style="list-style-type: none"> Approximately 44.1 lbs. [20 kg]
Power Consumption	<ul style="list-style-type: none"> 210 watts (during LQ self test) 2.8A (120VAC), 1.6A (230VAC) 34 watts (during stand-by) 0.6A (120VAC), 0.4A (230VAC) 13 watts(sleeping mode) 0.3A(120VAC), 0.2A(230VAC)

Appendix B. Control code summary

IBM mode

ITEM	SYMBOL	Hexadecimal & Decimal	FUNCTION																																																																																										
[1]	BEL	[07] H [7] D	Activates the alarm.																																																																																										
[2]	BS	[08] H [8] D	Backspaces one character.																																																																																										
[3]	HT	[09] H [9] D	Moves to next horizontal tab.																																																																																										
[4]	LF	[0A] H [10] D	Linefeeds after printing.																																																																																										
[5]	VT	[0B] H [11] D	Linefeeds to next vertical tab position after printing.																																																																																										
[6]	FF	[0C] H [12] D	Form feeds after printing.																																																																																										
[7]	CR	[0D] H [13] D	Carriage return after printing.																																																																																										
[8]	SO	[0E] H [14] D	Sets double width character mode for 1 line.																																																																																										
[9]	SI	[0F] H [15] D	Sets condensed pica character mode (17.1 cpi).																																																																																										
[10]	DC1	[11] H [17] D	Selects printer that has been deselected by ESC Q (23).																																																																																										
[11]	DC2	[12] H [18] D	Selects pica (10cpi) mode.																																																																																										
[12]	DC4	[14] H [20] D	Cancel double width character mode set by SO.																																																																																										
[13]	CAN	[18] H [24] D	Clears data in buffer.																																																																																										
[14]	ESC EM n	[1B,19,n] H [27,25,n] D	Control cut sheet feeder. n=1: selects bin 1 n=2: selects bin 2 n=R: ejects single sheet paper loaded in the printer This command is effective at the following conditions. The paper select lever is set to the single sheet setting. #49 CSF OPTION is set to SINGLE or DOUBLE.																																																																																										
[15]	ESC *m n1 n2	[1B,2A,m,n1,n2] H [27,42,m,n1,n2] D	Sets various graphic modes. This command is effective only when AGM mode is set to ON in the extended setup options.																																																																																										
<table border="1"> <thead> <tr> <th>m</th> <th>Graphic Type</th> <th>Number of Pins</th> <th>Maximum Columns</th> <th>Horizontal Density</th> </tr> </thead> <tbody> <tr> <td>0</td> <td>Standard-density</td> <td>8</td> <td>816</td> <td>60</td> </tr> <tr> <td>1</td> <td>Double-density</td> <td>8</td> <td>1632</td> <td>120</td> </tr> <tr> <td>2</td> <td>Double-speed double-density*</td> <td>8</td> <td>1632</td> <td>120</td> </tr> <tr> <td>3</td> <td>Quadruple-density *</td> <td>8</td> <td>3264</td> <td>240</td> </tr> <tr> <td>4</td> <td>CRT I</td> <td>8</td> <td>1088</td> <td>80</td> </tr> <tr> <td>6</td> <td>CRT II</td> <td>8</td> <td>1224</td> <td>90</td> </tr> <tr> <td>32</td> <td>Standard-density</td> <td>24</td> <td>816</td> <td>60</td> </tr> <tr> <td>33</td> <td>Double-density</td> <td>24</td> <td>1632</td> <td>120</td> </tr> <tr> <td>38</td> <td>CRT III</td> <td>24</td> <td>1224</td> <td>90</td> </tr> <tr> <td>39</td> <td>Triple-density</td> <td>24</td> <td>2448</td> <td>180</td> </tr> <tr> <td>40</td> <td>Quadruple-density*</td> <td>24</td> <td>4896</td> <td>360</td> </tr> </tbody> </table> <p>Note (*): Horizontal adjacent dots can not be printed.</p> <p>The total column number is calculated by $n1+n2 \times 256$ for 8-pin graphics and $(n1+n2 \times 256) \times 3$ for 24-pin graphics.</p> <p>Each bit data in the 8-pin graphics corresponds to 2 print pins of the print head.</p> <p>The following figure shows one column of data and its corresponding print position.</p> <table style="margin-left: auto; margin-right: auto;"> <tr> <td>Bit Data (MSB)</td> <td>1</td> <td>1</td> <td>1</td> <td>0</td> <td>1</td> <td>0</td> <td>1</td> <td>1</td> <td>(LSB)</td> </tr> <tr> <td></td> <td>↓</td> <td>↓</td> <td>↓</td> <td>↓</td> <td>↓</td> <td>↓</td> <td>↓</td> <td>↓</td> <td></td> </tr> <tr> <td>Print Pin (Top)</td> <td>●</td> <td>●</td> <td>●</td> <td>○</td> <td>●</td> <td>○</td> <td>●</td> <td>●</td> <td>(Bottom)</td> </tr> </table>				m	Graphic Type	Number of Pins	Maximum Columns	Horizontal Density	0	Standard-density	8	816	60	1	Double-density	8	1632	120	2	Double-speed double-density*	8	1632	120	3	Quadruple-density *	8	3264	240	4	CRT I	8	1088	80	6	CRT II	8	1224	90	32	Standard-density	24	816	60	33	Double-density	24	1632	120	38	CRT III	24	1224	90	39	Triple-density	24	2448	180	40	Quadruple-density*	24	4896	360	Bit Data (MSB)	1	1	1	0	1	0	1	1	(LSB)		↓	↓	↓	↓	↓	↓	↓	↓		Print Pin (Top)	●	●	●	○	●	○	●	●	(Bottom)
m	Graphic Type	Number of Pins	Maximum Columns	Horizontal Density																																																																																									
0	Standard-density	8	816	60																																																																																									
1	Double-density	8	1632	120																																																																																									
2	Double-speed double-density*	8	1632	120																																																																																									
3	Quadruple-density *	8	3264	240																																																																																									
4	CRT I	8	1088	80																																																																																									
6	CRT II	8	1224	90																																																																																									
32	Standard-density	24	816	60																																																																																									
33	Double-density	24	1632	120																																																																																									
38	CRT III	24	1224	90																																																																																									
39	Triple-density	24	2448	180																																																																																									
40	Quadruple-density*	24	4896	360																																																																																									
Bit Data (MSB)	1	1	1	0	1	0	1	1	(LSB)																																																																																				
	↓	↓	↓	↓	↓	↓	↓	↓																																																																																					
Print Pin (Top)	●	●	●	○	●	○	●	●	(Bottom)																																																																																				
[16]	ESC - n	[1B,2D,n] H [27,45,n] D	Sets or cancels underline mode. n=0: underline is cancelled. n=1: underline is set.																																																																																										
[17]	ESC 0	[1B,30] H [27,48] D	Sets line spacing to 1/8".																																																																																										
[18]	ESC 1	[1B,31] H [27,49] D	Sets line spacing to 7/72".																																																																																										
[19]	ESC 2	[1B,32] H [27,50] D	Linefeeds with the line spacing set by ESC A.																																																																																										
[20]	ESC 3 n	[1B,33,n] H [27,51,n] D	Sets line spacing in the basic spacing set by ESC [\. The default is $n/216''$ ($1 \leq n \leq 255$) in standard mode or $n/180''$ ($0 \leq n \leq 255$) in AGM mode.																																																																																										

ITEM	SYMBOL	Hexadecimal Decimal	FUNCTION
[21]	ESC 4	[1B,34] H [27,52] D	Sets the top-of-form (TOF) at the current print line.
[22]	ESC 5 n	[1B,35,n] H [27,53,n] D	Sets/cancels auto linefeed with CR n=0: Carriage return without linefeed. n=1: Carriage return with linefeed.
[23]	ESC 6	[1B,36] H [27,54] D	Selects IBM character set 2.
[24]	ESC 7	[1B,37] H [27,55] D	Selects IBM character set 1.
[25]	ESC :	[1B,3A] H [27,58] D	Sets elite (12cpi) mode.
[26]	ESC = n1 n2 id lo hi data	[1B,3D,n1,n2,23,lo,hi] H [27,61,n1,n2,35,lo,hi] D	Defines download character. When n1=n2=0, the download area is cleared. The number of data bytes following n2 is defined as n1+n2×256 (including three bytes of id, lo, hi). id is always 23h. lo and hi compose two-byte address where the first downloading character is to be stored and the following data are stored in the successive addresses.
[27]	ESC A n	[1B,41,n] H [27,65,n] D	Sets line spacing to n/72" (1≤n≤255) or to n/60" (1≤n≤255) in AGM mode.
[28]	ESC B n1 n2... n64 NUL	[1B,42,n1,n2,...n64,00] H [27,66,n1,n2,...n64,0] D	Sets vertical tab positions beginning from n1 and end with NUL [00]H. n1=1 is the first line at the TOF.
[29]	ESC C n	[1B,43,n] H [27,67,n] D	Sets page length in lines (1≤n≤255). The current print line becomes TOF (top-of-form). The bottom margin set by ESC N is cancelled.
[30]	ESC C NUL n	[1B,43,00,n] H [27,67,0,n] D	Sets page length in inches (1≤n≤182). The current print line becomes TOF (top of form).
[31]	ESC D n1 n2...n28 NUL	[1B,44,n1,n2,...n28,00] H [27,68,n1,n2,...n28,0] D	Sets horizontal tab position (1≤n≤255). n indicates the number of spaces from the left margin with the character width at the command execution. Left/right margins clear the tab positions. n1=1 is at the first column from the left margin.
[32]	ESC E	[1B,45] H [27,69] D	Sets emphasized character mode. Underline and graphic characters are also emphasized.
[33]	ESC F	[1B,46] H [27,70] D	Cancels emphasized character mode.
[34]	ESC G	[1B,47] H [27,71] D	Sets double strike character mode.
[35]	ESC H	[1B,48] H [27,72] D	Cancels double strike character mode.
[36]	ESC I n	[1B,49] H [27,73] D	Selects one of font styles. n=0: draft 10cpi n=2: LQ 10cpi n=3: LQ proportional n=4: download Draft 10cpi n=6: download LQ 10cpi n=7: download LQ proportional n=8: draft 12cpi n=10: LQ 12cpi n=12: download draft 12cpi n=14: download LQ 12cpi n=16: condensed draft n=18: condensed LQ n=20: download condensed draft n=22: download condensed LQ
[37]	ESC J n	[1B,4A,n] H [27,74,n] D	Linefeeds in the basic spacing set by ESC [\ after printing. The default is n/216" (1≤n≤255) in standard mode or n/180" (0≤n≤255) in AGM mode.

ITEM	SYMBOL	Hexadecimal Decimal	FUNCTION
[38]	ESC K n1 n2 data	[1B,4B,n1,n2,data] H [27,75,n1,n2,data] D	Prints the 8-pin Standard-density graphic mode(60dpi) The total number of dots in the data is set by n1+n2×256 .
[39]	ESC L n1 n2 data	[1B,4C,n1,n2,data] H [27,76,n1,n2,data] D	Prints the 8-pin Double-density graphic mode(120dpi) The total number of dots in the data is set by n1+n2×256 .
[40]	ESC N n	[1B,4E,n] H [27,78,n] D	Sets bottom margin (1≤n≤255). n specifies the number of lines not to be printed at the end of a page. For example: If the line spacing is 1/6 inch and the page length is 66 lines, an ESC N 6 command causes the printer to print 60 lines, then skip 6 lines. The space to be skipped is 1 inch (1/6 inch x 6).
[41]	ESC O	[1B,4F] H [27,79] D	Cancels the bottom margin set by ESC N.
[42]	ESC P n	[1B,50] H [27,80] D	Sets/cancels proportional mode. n=0: the proportional mode is cancelled n=1: the proportional mode is selected
[43]	ESC Q n	[1B,51,23] H [27,81,35] D	Deselects the printer. DC1 selects the printer. n=23h: the printer is deselected n≠23h: this command is ignored
[44]	ESC R	[1B,52] H [27,82] D	Initializes horizontal tabs to every 8th column starting from 9th column and clears vertical tabs.
[45]	ESC S n	[1B,53,n] H [27,83,n] D	Sets superscript or subscript character mode. n=0: the superscript character mode is set n=1: the subscript character mode is set
[46]	ESC T	[1B,54] H [27,84] D	Cancels super/subscript character mode.
[47]	ESC U n	[1B,55,n] H [27,85,n] D	Sets or cancels unidirectional printing. n=0: the unidirectional printing is cancelled and the bidirectional or predirectional is set according to the setup options n=1: unidirectional printing is set
[48]	ESC W n	[1B,57,n] H [27,87,n] D	Sets or cancels double width character mode. n=0: the double width character mode is cancelled n=1: the double width character mode is set
[49]	ESC X n m	[1B,5C,n,m] H [27,92,n,m] D	Sets left and right margins (0≤n<m≤255) n: left margin, m: right margin The print area is between the n th and m th column.
[50]	ESC Y n1 n2 data	[1B,59,n1,n2,data] H [27,89,n1,n2,data] D	Prints 8-pin double-speed double-density graphic mode (120dpi). The total number of dots in the data is set by n1+n2×256 .
[51]	ESC Z n1 n2 data	[1B,5A,n1,n2,data] H [27,90,n1,n2,data] D	Prints 8-pin quadruple-density graphic mode (240dpi). The total number of dots in the data is set by n1 + n2 x 256 .
[52]	ESC [- n1 n2 m1 m2	[1B,5B,2D,n1,n2,m1,m2] H [27,91,45,n1,n2,m1,m2] D	Sets various line modes. n1=2 and n2=0 m1=01h: Underline is set m1=02h: Strike-through is set m1=03h: Overscore is set m2=00h: line mode at m1 is cancelled m2=01h: Single line is set m2=02h: Double line is set m2=FFh: all line modes are cancelled

ITEM	SYMBOL	Hexadecimal Decimal	FUNCTION
[53]	ESC [@ n1 n2 m1...m4	[1B,5B,40,n1,n2,m1,...,m4] H [27,91,64,n1,n2,m1,...,m4] D	Sets single or double height/width/line-spacing mode. n1=4, n2=0, and m2=0. m1=00h: no change m1=01h: italic style is set m1=02h: italic style is cancelled m1=04h: outline style is set m1=08h: outline style is cancelled m1=10h: shadow style is set m1=20h: shadow style is cancelled m3=00h: no change m3=01h: single character height m3=02h: double character height m3=10h: single line spacing m3=11h: single char. height/single line spacing m3=12h: double char. height/single line spacing m3=20h: double line spacing m3=21h: single char. height/double line spacing m3=22h: double char. height/double line spacing m4=00h: no change m4=01h: single character width. m4=02h: double character width.
[54]	ESC [I n1 n2 Hf, Lf, Hs, Ls Sm, 00, Hc, Lc	[1B,5B,49,n1,n2,Hf,Lf, Hs,Ls,Sm,00,Hc,Lc] H [27,91,73,n1,n2,Hf,Lf,	Selects character attributes (font, character spacing/ size, and/or code page in the following format. The number of parameter bytes following n1 and n2 is defined by n1+n2×256 .

1. Select a font, character style, and spacing in the following tables: (**n1=2** and **n2=0**)

Normal Character Style Table (Hf: Upper byte, Lf: Lower byte)

Hf/Lf (Hex)	10cpi	12cpi	15cpi	17cpi	20cpi	24cpi	Proportional
Courier	00/0B	01/EB	01/EC	01/ED	01/EE	01/1E	01/AB
Prestige	00/0C	01/EF	01/F0	01/C9	01/CA	01/1F	00/A4
Gothic	00/24	01/8F	01/8E	01/8D	01/8C	01/20	00/AE
Orator-S	00/19	01/D0	01/D1	01/D2	01/D3	01/23	00/C7
Orator	00/05	01/CB	01/CC	01/CD	01/CE	01/21	00/C6
Script	01/D4	01/D5	01/D6	01/D7	01/D8	01/24	00/C8

Various Character Style Table (Hf: Upper byte, Lf: Lower byte)

Character Styles Hf/Lf (Hex)	Normal	Italic	Emphasized	Emphasized Italic	Double-Width Double-Height	Double-Width Double-Height Emphasized	Double-Width Double-Height Double-Strike
Courier 10 cpi	—	00/12	00/2E	00/39	00/F4	00/F5	—
Courier 12 cpi	00/55	00/5C	00/6C	00/74	—	—	—
Courier 15 cpi	00/DF	00/D7	00/D6	00/D8	—	—	—
Courier 17 cpi	00/FE	—	00/FD	—	—	—	—
Courier Prop.	—	00/AC	00/B8	00/B9	—	—	—
Prestige 10 cpi	—	—	00/3C	—	—	—	—
Prestige 12 cpi	00/56	00/70	00/6F	—	—	—	—
Prestige 15 cpi	00/DD	—	—	—	—	—	—
Prestige 17 cpi	01/00	—	—	—	—	—	—
Gothic 10 cpi	—	—	—	—	00/F1	00/F2	00/F3
Gothic 12 cpi	00/57	00/6D	00/6E	—	—	—	—
Gothic 15 cpi	00/DE	—	—	—	—	—	—
Gothic 17 cpi	00/FF	—	—	—	—	—	—
Gothic 20 cpi	01/19	—	—	—	—	—	—
Gothic Prop.	—	00/A2	00/9D	—	—	—	—

ITEM	SYMBOL	Hexadecimal	Decimal	FUNCTION																																																																		
		<p>2. Select a character style, and spacing in the following tables (Hf, Lf is ignored): (n1=6, n2=0, Hf=0, Lf=0, and S=1)</p> <p>Character Spacing and Style Table (Hs: Upper byte, Ls: Lower byte)</p> <table border="1"> <thead> <tr> <th>Hs</th> <th>Ls</th> <th></th> <th>Hs</th> <th>Ls</th> <th></th> </tr> </thead> <tbody> <tr> <td>00</td> <td>00-41</td> <td>24 cpi, Subscript</td> <td>00</td> <td>84-9B</td> <td>10 cpi, Normal</td> </tr> <tr> <td>00</td> <td>42-4D</td> <td>20 cpi, Subscript</td> <td>00</td> <td>9C-B3</td> <td>17 cpi, Double-Width</td> </tr> <tr> <td>00</td> <td>4E-59</td> <td>17 cpi, Normal</td> <td>00</td> <td>B4-D7</td> <td>15 cpi, Double-Width</td> </tr> <tr> <td>00</td> <td>5A-6B</td> <td>15 cpi, Normal</td> <td>00</td> <td>D8-FE</td> <td>12 cpi, Double-Width, Double-Height</td> </tr> </tbody> </table> <p>3. Select a proportional spaced character: (n1=6, n2=0, Hf=Lf=Hc=Lc, and S=2) (n1=6, n2=0, Hf=Lf=Hc=Lc="Don't care", and S=2 or 3)</p> <p>4. Select a code page in the following tables: (n1=8, n2=0, and Hf=Lf=Hc=Lc=S="Don't care")</p> <p>Code Page Table (Hc: Upper byte, Lc: Lower byte)</p> <table border="1"> <thead> <tr> <th>Hc</th> <th>Lc</th> <th>Code page</th> </tr> </thead> <tbody> <tr><td>01h</td><td>B5h</td><td>437</td></tr> <tr><td>03h</td><td>52h</td><td>850</td></tr> <tr><td>03h</td><td>5Ch</td><td>860</td></tr> <tr><td>03h</td><td>5Fh</td><td>863</td></tr> <tr><td>03h</td><td>61h</td><td>865</td></tr> <tr><td>03h</td><td>59h</td><td>857</td></tr> <tr><td>40h</td><td>00h</td><td>ISO-1</td></tr> <tr><td>03h</td><td>5Ah</td><td>858</td></tr> <tr><td>03h</td><td>5Dh</td><td>861</td></tr> <tr><td>0Fh</td><td>07h</td><td>BRASCII</td></tr> <tr><td>0Fh</td><td>08h</td><td>ABICOMP</td></tr> </tbody> </table>			Hs	Ls		Hs	Ls		00	00-41	24 cpi, Subscript	00	84-9B	10 cpi, Normal	00	42-4D	20 cpi, Subscript	00	9C-B3	17 cpi, Double-Width	00	4E-59	17 cpi, Normal	00	B4-D7	15 cpi, Double-Width	00	5A-6B	15 cpi, Normal	00	D8-FE	12 cpi, Double-Width, Double-Height	Hc	Lc	Code page	01h	B5h	437	03h	52h	850	03h	5Ch	860	03h	5Fh	863	03h	61h	865	03h	59h	857	40h	00h	ISO-1	03h	5Ah	858	03h	5Dh	861	0Fh	07h	BRASCII	0Fh	08h	ABICOMP
Hs	Ls		Hs	Ls																																																																		
00	00-41	24 cpi, Subscript	00	84-9B	10 cpi, Normal																																																																	
00	42-4D	20 cpi, Subscript	00	9C-B3	17 cpi, Double-Width																																																																	
00	4E-59	17 cpi, Normal	00	B4-D7	15 cpi, Double-Width																																																																	
00	5A-6B	15 cpi, Normal	00	D8-FE	12 cpi, Double-Width, Double-Height																																																																	
Hc	Lc	Code page																																																																				
01h	B5h	437																																																																				
03h	52h	850																																																																				
03h	5Ch	860																																																																				
03h	5Fh	863																																																																				
03h	61h	865																																																																				
03h	59h	857																																																																				
40h	00h	ISO-1																																																																				
03h	5Ah	858																																																																				
03h	5Dh	861																																																																				
0Fh	07h	BRASCII																																																																				
0Fh	08h	ABICOMP																																																																				
[55]	ESC [K n1 n2 m1...m4	[1B,5B,4B,n1,n2,m1,...,m4] H [27,92,75,n1,n2,m1,...,m4] D		<p>Software initialization. The number of data bytes following n2 is defined as n1+n2×256.</p> <table border="1"> <thead> <tr> <th>Code</th> <th>Initialize condition</th> </tr> </thead> <tbody> <tr> <td>m1 00h, 04h, FEh</td> <td>initializes without clearing download area</td> </tr> <tr> <td>01h, 05h, FFh</td> <td>initializes with clearing download area</td> </tr> <tr> <td>m2 03h, 16h, 23h</td> <td>indicates information defined by m3 and m4</td> </tr> <tr> <td>24h, B1h, B4</td> <td>following m2.</td> </tr> <tr> <td colspan="2">m3 and m4 indicates the combination of each parameters:</td> </tr> <tr> <td>m3</td> <td>m4</td> </tr> <tr> <td>bit7 valid (0) or invalid (1) of m3</td> <td>valid (0) or invalid (1) of m4</td> </tr> <tr> <td>bit6 —</td> <td>Code page 437 (0) or 850 (1)</td> </tr> <tr> <td>bit5 —</td> <td>—</td> </tr> <tr> <td>bit4 LF=LF (0) or LF=CR+LF (1)</td> <td>—</td> </tr> <tr> <td>bit3 CR=CR (0) or CR=CR+LF (1)</td> <td>—</td> </tr> <tr> <td>bit2 Page length of 11" (0) or 12" (1)</td> <td>—</td> </tr> <tr> <td>bit1 Non-slash zero (0) or slashed zero (1)</td> <td>Print line width of 13.6" (0) or 8" (1)</td> </tr> <tr> <td>bit0 Character set 1 (0) or set 2 (1)</td> <td>—</td> </tr> </tbody> </table>	Code	Initialize condition	m1 00h, 04h, FEh	initializes without clearing download area	01h, 05h, FFh	initializes with clearing download area	m2 03h, 16h, 23h	indicates information defined by m3 and m4	24h, B1h, B4	following m2 .	m3 and m4 indicates the combination of each parameters:		m3	m4	bit7 valid (0) or invalid (1) of m3	valid (0) or invalid (1) of m4	bit6 —	Code page 437 (0) or 850 (1)	bit5 —	—	bit4 LF=LF (0) or LF=CR+LF (1)	—	bit3 CR=CR (0) or CR=CR+LF (1)	—	bit2 Page length of 11" (0) or 12" (1)	—	bit1 Non-slash zero (0) or slashed zero (1)	Print line width of 13.6" (0) or 8" (1)	bit0 Character set 1 (0) or set 2 (1)	—																																				
Code	Initialize condition																																																																					
m1 00h, 04h, FEh	initializes without clearing download area																																																																					
01h, 05h, FFh	initializes with clearing download area																																																																					
m2 03h, 16h, 23h	indicates information defined by m3 and m4																																																																					
24h, B1h, B4	following m2 .																																																																					
m3 and m4 indicates the combination of each parameters:																																																																						
m3	m4																																																																					
bit7 valid (0) or invalid (1) of m3	valid (0) or invalid (1) of m4																																																																					
bit6 —	Code page 437 (0) or 850 (1)																																																																					
bit5 —	—																																																																					
bit4 LF=LF (0) or LF=CR+LF (1)	—																																																																					
bit3 CR=CR (0) or CR=CR+LF (1)	—																																																																					
bit2 Page length of 11" (0) or 12" (1)	—																																																																					
bit1 Non-slash zero (0) or slashed zero (1)	Print line width of 13.6" (0) or 8" (1)																																																																					
bit0 Character set 1 (0) or set 2 (1)	—																																																																					
[56]	ESC [T n1 n2 m1...m4	[1B,5B,54,n1,n2,m1,...,m4] H [27,92,84,n1,n2,m1,...,m4] D		<p>Selects code page. n1=4, n2=0, m1=0, and m2=0.</p> <table border="1"> <thead> <tr> <th>m3</th> <th>m4</th> <th>Code page</th> <th>m3</th> <th>m4</th> <th>Code page</th> </tr> </thead> <tbody> <tr><td>01h</td><td>B5h</td><td>437</td><td>03h</td><td>5Ah</td><td>858</td></tr> <tr><td>03h</td><td>52h</td><td>850</td><td>03h</td><td>5Dh</td><td>861</td></tr> <tr><td>03h</td><td>5Ch</td><td>860</td><td>0Fh</td><td>07h</td><td>BRASCII</td></tr> <tr><td>03h</td><td>5Fh</td><td>863</td><td>0Fh</td><td>08h</td><td>ABICOMP</td></tr> <tr><td>03h</td><td>61h</td><td>865</td><td></td><td></td><td></td></tr> <tr><td>03h</td><td>59h</td><td>857</td><td></td><td></td><td></td></tr> <tr><td>40h</td><td>00h</td><td>ISO-1</td><td></td><td></td><td></td></tr> </tbody> </table>	m3	m4	Code page	m3	m4	Code page	01h	B5h	437	03h	5Ah	858	03h	52h	850	03h	5Dh	861	03h	5Ch	860	0Fh	07h	BRASCII	03h	5Fh	863	0Fh	08h	ABICOMP	03h	61h	865				03h	59h	857				40h	00h	ISO-1																					
m3	m4	Code page	m3	m4	Code page																																																																	
01h	B5h	437	03h	5Ah	858																																																																	
03h	52h	850	03h	5Dh	861																																																																	
03h	5Ch	860	0Fh	07h	BRASCII																																																																	
03h	5Fh	863	0Fh	08h	ABICOMP																																																																	
03h	61h	865																																																																				
03h	59h	857																																																																				
40h	00h	ISO-1																																																																				

ITEM	SYMBOL	Hexadecimal Decimal	FUNCTION																																																		
[57]	ESC [\ n1 n2 m1...m4	[1B,5B,5C,n1,n2,m1,...m4] H [27,91,92,n1,n2,m1,...m4] D	Sets basic line spacing to 1/180", 1/216", or 1/360". n1=4, n2=0, m1=0, and m2=0 The basic line spacing affects the amount of the line feeding at ESC J and ESC 3. <table border="1" style="margin-left: auto; margin-right: auto;"> <thead> <tr> <th>m3</th> <th>m4</th> <th>Basic line spacing</th> </tr> </thead> <tbody> <tr> <td>180</td> <td>0</td> <td>1/180" line spacing (AGM)</td> </tr> <tr> <td>216</td> <td>0</td> <td>1/216" line spacing</td> </tr> <tr> <td>104</td> <td>1</td> <td>1/360" line spacing</td> </tr> </tbody> </table>	m3	m4	Basic line spacing	180	0	1/180" line spacing (AGM)	216	0	1/216" line spacing	104	1	1/360" line spacing																																						
m3	m4	Basic line spacing																																																			
180	0	1/180" line spacing (AGM)																																																			
216	0	1/216" line spacing																																																			
104	1	1/360" line spacing																																																			
[58]	ESC [d n1 n2 m	[1B,5B,64,n1,n2,m] H [27,91,100,n1,n2,m] D	Selects print character quality. n1=1 and n2=0 m=00h : no change m=01h-7Fh : draft character quality m=80h-BFh and FFh : LQ character quality m=C0h-FEh : emphasized LQ character quality																																																		
[59]	ESC [g n1 n2 m data	[1B,5B,67,n1,n2,m,data] H [27,91,103,n1,n2,m,data] D	Sets various graphic modes. <table border="1" style="margin-left: auto; margin-right: auto;"> <thead> <tr> <th>m</th> <th>Graphic Type</th> <th>Number of Pins</th> <th>Maximum Columns</th> <th>Horizontal Density</th> </tr> </thead> <tbody> <tr> <td>0</td> <td>Standard-density</td> <td>8</td> <td>816</td> <td>60</td> </tr> <tr> <td>1</td> <td>Double-density</td> <td>8</td> <td>1632</td> <td>120</td> </tr> <tr> <td>2</td> <td>Double-speed double-density **</td> <td>8</td> <td>1632</td> <td>120</td> </tr> <tr> <td>3</td> <td>Quadruple-density **</td> <td>8</td> <td>3264</td> <td>240</td> </tr> <tr> <td>8</td> <td>Standard-density</td> <td>24</td> <td>816</td> <td>60</td> </tr> <tr> <td>9</td> <td>Double-density</td> <td>24</td> <td>1632</td> <td>120</td> </tr> <tr> <td>11</td> <td>Triple-density</td> <td>24</td> <td>2448</td> <td>180</td> </tr> <tr> <td>12</td> <td>Hex-density**</td> <td>24</td> <td>4896</td> <td>360</td> </tr> <tr> <td>16</td> <td>Hex-density**</td> <td>48</td> <td>4896</td> <td>360</td> </tr> </tbody> </table> Note (**): Horizontal adjacent dots can not be printed. The number of data bytes following n1 and n2 is defined as the total column number for 8-pin graphics (one byte/column) plus one extra parameter byte (m). 24-pin graphics takes three bytes/column and 48-pin graphics takes six bytes/column. Each bit data in the 8-pin and 48-pin graphics corresponds to 2 print pins of the print head. The following figure shows one column of data and its corresponding print position. Note (*): These pins become active when both adjacent print pins are activated.	m	Graphic Type	Number of Pins	Maximum Columns	Horizontal Density	0	Standard-density	8	816	60	1	Double-density	8	1632	120	2	Double-speed double-density **	8	1632	120	3	Quadruple-density **	8	3264	240	8	Standard-density	24	816	60	9	Double-density	24	1632	120	11	Triple-density	24	2448	180	12	Hex-density**	24	4896	360	16	Hex-density**	48	4896	360
m	Graphic Type	Number of Pins	Maximum Columns	Horizontal Density																																																	
0	Standard-density	8	816	60																																																	
1	Double-density	8	1632	120																																																	
2	Double-speed double-density **	8	1632	120																																																	
3	Quadruple-density **	8	3264	240																																																	
8	Standard-density	24	816	60																																																	
9	Double-density	24	1632	120																																																	
11	Triple-density	24	2448	180																																																	
12	Hex-density**	24	4896	360																																																	
16	Hex-density**	48	4896	360																																																	
[60]	ESC \ n1 n2 data	[1B,5C,n1,n2,data] H [1B,92,n1,n2,data] D	Prints characters from all character set. The number of character to be printed is defined by n1+n2×256 .																																																		
[61]	ESC]	[1B,5D] H [27,92] D	Reverse line feeds by the current line spacing.																																																		
[62]	ESC ^ n	[1B,5E,n] H [27,94,n] D	Prints one character (n: character code) from all character set.																																																		
[63]	ESC _ n	[1B,5F,n] H [27,95,n] D	Sets or cancels overscore mode. n=0 : the overscore mode is cancelled n=1 : the overscore mode is set																																																		
[64]	ESC d n1 n2	[1B,64,n1,n2] H [27,100,n1,n2] D	Sets relative print position. (n1+n2×256)/120" from current position																																																		
[65]	ESC j	[1B,6A] H [27,106] D	Stops printing and sets the printer in offline.																																																		

□ EPSON mode

ITEM	SYMBOL	Hexadecimal & Decimal	FUNCTION																																								
[1]	BEL	[07] H [7] D	Activates the bell.																																								
[2]	BS	[08] H [8] D	Backspace one character.																																								
[3]	HT	[09] H [9] D	Moves to next horizontal tab.																																								
[4]	LF	[0A] H [10] D	Linefeeds after printing.																																								
[5]	VT	[0B]H [11] D	Linefeeds to next vertical tab position after printing.																																								
[6]	FF	[0C] H [12] D	Form feeds after printing.																																								
[7]	CR	[0D] H [13] D	Carriage return after printing.																																								
[8]	SO ESC SO	[0E] H [14] D [1B,0E] H [27,14] D	Sets double width character mode for 1 line. DC4, LF, FF, ESC N, and ESC ! cancel this mode.																																								
[9]	SI ESC SI	[0F] H [15] D [1B,0F] H [27,15] D	Sets condensed character mode. 10 and 12 cpi becomes 17.1 and 20 cpi, respectively.																																								
[10]	DC1	[11] H [17] D	Selects printer that has been deselected by DC3.																																								
[11]	DC2	[12] H [18] D	Cancel condensed character mode.																																								
[12]	DC3	[13] H [19] D	Deselects printer.																																								
[13]	DC4	[14] H [20] D	Cancel double width character mode set by SO.																																								
[14]	CAN	[18] H [24] D	Clears data in buffer and move print head to home position.																																								
[15]	DEL	[7F] H [127] D	Deletes one character.																																								
[16]	ESC EM n	[1B,19,n] H [27,25,n] D	Controls cut sheet feeder. n=1 : selects bin 1 n=2 : selects bin 2 n=R : ejects single sheet paper loaded in the printer This command is effective at the following conditions. The paper select lever is set to the single sheet setting. #49 CSF OPTION is set to SINGLE or DOUBLE.																																								
[17]	ESC SP n	[1B,20,n] H [27,32,n] D 0≤n≤127	Sets intercharacter space in dot units. The dot width in pica mode is 1/120 inch.																																								
		<table border="1"> <thead> <tr> <th colspan="2">Print mode</th> <th>Dot width</th> </tr> </thead> <tbody> <tr> <td>Draft</td> <td></td> <td>1/120 inch</td> </tr> <tr> <td>LQ/Proportional</td> <td></td> <td>1/180 inch</td> </tr> </tbody> </table>		Print mode		Dot width	Draft		1/120 inch	LQ/Proportional		1/180 inch																															
Print mode		Dot width																																									
Draft		1/120 inch																																									
LQ/Proportional		1/180 inch																																									
[18]	ESC ! n	[1B,21,n] H [27,33,n] D	Sets multiple print modes. n is specified by the following bit combination. (0≤n≤255)																																								
		<table border="1"> <thead> <tr> <th>Print modes</th> <th>Dec.</th> <th>Hex.</th> <th>Correspond command</th> </tr> </thead> <tbody> <tr> <td>Pica</td> <td>0</td> <td>00</td> <td>ESC P</td> </tr> <tr> <td>Elite</td> <td>1</td> <td>01</td> <td>ESC M</td> </tr> <tr> <td>Proportional</td> <td>2</td> <td>02</td> <td>ESC p</td> </tr> <tr> <td>Condensed</td> <td>4</td> <td>04</td> <td>SI, DC1</td> </tr> <tr> <td>Emphasized</td> <td>8</td> <td>08</td> <td>ESC E, ESC F</td> </tr> <tr> <td>Double strike</td> <td>16</td> <td>10</td> <td>ESC G, ESC H</td> </tr> <tr> <td>Double width</td> <td>32</td> <td>20</td> <td>ESC W</td> </tr> <tr> <td>Italic</td> <td>64</td> <td>40</td> <td>ESC 4, ESC 5</td> </tr> <tr> <td>Underline</td> <td>128</td> <td>80</td> <td>ESC -</td> </tr> </tbody> </table> <p>Note: Proportional cannot be specified with elite or condensed, and has higher priority.</p>		Print modes	Dec.	Hex.	Correspond command	Pica	0	00	ESC P	Elite	1	01	ESC M	Proportional	2	02	ESC p	Condensed	4	04	SI, DC1	Emphasized	8	08	ESC E, ESC F	Double strike	16	10	ESC G, ESC H	Double width	32	20	ESC W	Italic	64	40	ESC 4, ESC 5	Underline	128	80	ESC -
Print modes	Dec.	Hex.	Correspond command																																								
Pica	0	00	ESC P																																								
Elite	1	01	ESC M																																								
Proportional	2	02	ESC p																																								
Condensed	4	04	SI, DC1																																								
Emphasized	8	08	ESC E, ESC F																																								
Double strike	16	10	ESC G, ESC H																																								
Double width	32	20	ESC W																																								
Italic	64	40	ESC 4, ESC 5																																								
Underline	128	80	ESC -																																								
[19]	ESC #	[1B,23] H [27,35] D	Cancel MSB control set by ESC = or ESC >.																																								

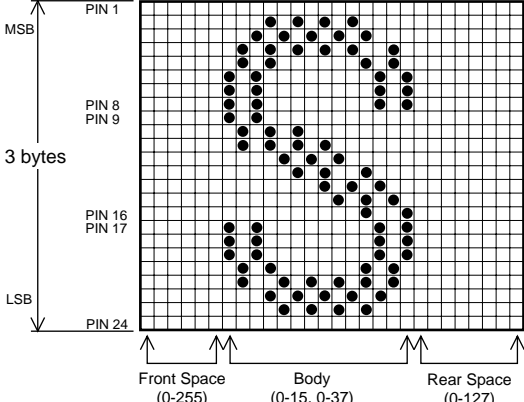
ITEM	SYMBOL	Hexadecimal Decimal	FUNCTION
[20]	ESC \$ n1 n2	[1B,24,n1,n2] H [27,36,n1,n2] D	Sets absolute dot position. The dot spacing is 1/60" and its position is $n1+n2 \times 256$ dots from the left margin.
[21]	ESC % n	[1B,25,n] H [27,37,n] D	Sets resident characters or download characters. n=0 : the resident character set is set. n=1 : the download character set is set.
[22]	ESC & NUL n m a0 a1 a2 data	[1B,26,00,n,m,a0,a1,a2,data] H [27,38,0,n,m,a0,a1,a2,data] D	<p>Defines download character(s).</p> <p>n: first code of download character (00-127) m: last code of download character (00-127) a0: front space (00-255) a1: body length (draft: 00-15, LQ/proportional: 00-37) a2: rear space (00-127)</p> <p>Note: Total character spacing is limited as; $0 < a0+a1 (+a2) < 42$ for LQ/proportional, and $0 < a0+a1 (+a2) < 18$ for draft.</p>  <p>Note: Super/subscript downloading character needs two bytes in each vertical dot column (height).</p>
[23]	ESC (- n1 n2 m d1 d2	[1B,28,2D,n1,n2,m,d1,d2] H [27,40,45,n1,n2,m,d1,d2] D	<p>Sets various line modes.</p> <p>n1=3, n2=0, and m=1</p> <p>d1=01h: Underline is set. d1=02h: Strike-through is set. d1=03h: Overscore is set.</p> <p>d2=00h: Line mode is cancelled. d2=01h: Single line is set. d2=02h: Double line is set. d2=05h: Single broken line is set. d2=06h: Double broken line is set.</p>
[24]	ESC (^ n1 n2 data	[1B,28,5E,n1,n2,data] H [27,40,94,n1,n2,data] D	<p>Prints character from all character set table. The number of character following n2 to be printed is defined by $n1+n2 \times 256$. This command is valid only when the character table is set to CODE PAGE in the extended setup options.</p>
[25]	ESC (t n1n2 d1 d2 d3	[27,40,116,n1 n2 d1 d2 d3] D [1B,28,74,n1 n2 d1 d2 d3] H	<p>Specifies a character set.</p> <p>d1: Displays ESC tn command table No. d2, d3: Specifies the character set. d2=0, d3=0 : ITALIC d2=1, d3=0 : PC-437 d2=3, d3=0 : PC-850 d2=7, d3=0 : PC-860</p>

ITEM	SYMBOL	Hexadecimal Decimal	FUNCTION																																																																																										
			d2=8,d3=0 : PC-863 d2=44,d3=0 : PC-858 d2=9,d3=0 : PC-865 d2=24,d3=0 : PC-861 d2=11,d3=0 : PC-857 d2=25,d3=0 : BRASCHII d2=17,d3=0 : ISO-8859-1 d2=26,d3=0 : ABICOMP																																																																																										
[26]	ESC *m n1 n2 data	[1B,2A,m,n1,n2,data] H [27,42,m,n1,n2,data] D	Sets various graphic modes. <table border="1" style="margin-left: 20px;"> <thead> <tr> <th>m</th> <th>Graphic Type</th> <th>Number of Pins</th> <th>Maximum Columns</th> <th>Horizontal Density</th> </tr> </thead> <tbody> <tr><td>0</td><td>Standard-density</td><td>8</td><td>816</td><td>60</td></tr> <tr><td>1</td><td>Double-density</td><td>8</td><td>1632</td><td>120</td></tr> <tr><td>2</td><td>Double-speed double-density*</td><td>8</td><td>1632</td><td>120</td></tr> <tr><td>3</td><td>Quadruple-density *</td><td>8</td><td>3264</td><td>240</td></tr> <tr><td>4</td><td>CRT I</td><td>8</td><td>1088</td><td>80</td></tr> <tr><td>6</td><td>CRT II</td><td>8</td><td>1224</td><td>90</td></tr> <tr><td>32</td><td>Standard-density</td><td>24</td><td>816</td><td>60</td></tr> <tr><td>33</td><td>Double-density</td><td>24</td><td>1632</td><td>120</td></tr> <tr><td>38</td><td>CRT III</td><td>24</td><td>1224</td><td>90</td></tr> <tr><td>39</td><td>Triple-density</td><td>24</td><td>2448</td><td>180</td></tr> <tr><td>40</td><td>Hex-density*</td><td>24</td><td>4896</td><td>360</td></tr> </tbody> </table> <p><i>Note</i> (*): Horizontal adjacent dots can not be printed. The total column number is calculated by n1+n2 x 256 for 8-pin graphics and (n1 + n2x256) x3 for 24-pin graphics. Each bit data in the 8-pin graphics corresponds to 2 print pins of the print head. The following figure shows one column of data and its corresponding print position.</p> <table style="margin-left: 20px;"> <tr> <td style="text-align: center;">Bit Data (MSB)</td> <td style="text-align: center;">1</td> <td style="text-align: center;">1</td> <td style="text-align: center;">1</td> <td style="text-align: center;">0</td> <td style="text-align: center;">1</td> <td style="text-align: center;">0</td> <td style="text-align: center;">1</td> <td style="text-align: center;">1</td> <td style="text-align: right;">(LSB)</td> </tr> <tr> <td></td> <td style="text-align: center;">↓</td> <td style="text-align: center;">↓</td> <td style="text-align: center;">↓</td> <td style="text-align: center;">↓</td> <td style="text-align: center;">↓</td> <td style="text-align: center;">↓</td> <td style="text-align: center;">↓</td> <td style="text-align: center;">↓</td> <td></td> </tr> <tr> <td style="text-align: center;">Print Pin (Top)</td> <td style="text-align: center;">●</td> <td style="text-align: center;">●</td> <td style="text-align: center;">●</td> <td style="text-align: center;">○</td> <td style="text-align: center;">●</td> <td style="text-align: center;">○</td> <td style="text-align: center;">●</td> <td style="text-align: center;">●</td> <td style="text-align: right;">(Bottom)</td> </tr> </table>	m	Graphic Type	Number of Pins	Maximum Columns	Horizontal Density	0	Standard-density	8	816	60	1	Double-density	8	1632	120	2	Double-speed double-density*	8	1632	120	3	Quadruple-density *	8	3264	240	4	CRT I	8	1088	80	6	CRT II	8	1224	90	32	Standard-density	24	816	60	33	Double-density	24	1632	120	38	CRT III	24	1224	90	39	Triple-density	24	2448	180	40	Hex-density*	24	4896	360	Bit Data (MSB)	1	1	1	0	1	0	1	1	(LSB)		↓	↓	↓	↓	↓	↓	↓	↓		Print Pin (Top)	●	●	●	○	●	○	●	●	(Bottom)
m	Graphic Type	Number of Pins	Maximum Columns	Horizontal Density																																																																																									
0	Standard-density	8	816	60																																																																																									
1	Double-density	8	1632	120																																																																																									
2	Double-speed double-density*	8	1632	120																																																																																									
3	Quadruple-density *	8	3264	240																																																																																									
4	CRT I	8	1088	80																																																																																									
6	CRT II	8	1224	90																																																																																									
32	Standard-density	24	816	60																																																																																									
33	Double-density	24	1632	120																																																																																									
38	CRT III	24	1224	90																																																																																									
39	Triple-density	24	2448	180																																																																																									
40	Hex-density*	24	4896	360																																																																																									
Bit Data (MSB)	1	1	1	0	1	0	1	1	(LSB)																																																																																				
	↓	↓	↓	↓	↓	↓	↓	↓																																																																																					
Print Pin (Top)	●	●	●	○	●	○	●	●	(Bottom)																																																																																				
[27]	ESC + n	[1B,2B,n] H [27,43,n] D	Sets line spacing to n/360" (0≤n≤255).																																																																																										
[28]	ESC - n	[1B,2D,n] H [27,45,n] D	Sets or cancels underline. n=0 : underline is cancelled n=1 : underline is set																																																																																										
[29]	ESC / c	[1B,2F,c] H [27,47,c] D	Selects a channel (c: 0-7) of vertical tab.																																																																																										
[30]	ESC 0	[1B,30] H [27,48] D	Sets line spacing to 1/8".																																																																																										
[31]	ESC 2	[1B,32] H [27,50] D	Sets line spacing to 1/6".																																																																																										
[32]	ESC 3 n	[1B,33,n] H [27,51,n] D	Sets line spacing to n/180" (0≤n≤255).																																																																																										
[33]	ESC 4	[1B,34] H [27,52] D	Sets italic character mode. Download characters and graphic characters (B0h-DFh, F4h, and F5h) are not italicized.																																																																																										
[34]	ESC 5	[1B,35] H [27,53] D	Cancels italic character mode.																																																																																										
[35]	ESC 6	[1B,36] H [27,54] D	Enlarges the print code area. Control code area (80h-9Fh) is printed as characters.																																																																																										
[36]	ESC 7	[1B,37] H [27,55] D	Clears ESC 6 command.																																																																																										
[37]	ESC : NUL n NUL	[1B,3A,00,n,00] H [27,58,0,n,0] D	Copy RAM download character set from ROM character set. n=00h : ROMAN is copied n=01h : SANS SERIF is copied n=02h : COURIER is copied n=03h : PRESTIGE is copied n=04h : SCRIPT is copied n=05h : OCR-B is copied n=06h : OCR-A is copied n=07h : ORATOR is copied n=08h : ORATOR-S is copied n=14h : GOTHIC is copied																																																																																										
[38]	ESC <	[1B,3C] H [27,60] D	Moves print head to home position.																																																																																										
[39]	ESC =	[1B,3D] H [27,61] D	Sets MSB of data to "0".																																																																																										
[40]	ESC >	[1B,3E] H [27,62] D	Sets MSB of data to "1".																																																																																										

ITEM	SYMBOL	Hexadecimal Decimal	FUNCTION																																																												
[41]	ESC ? n m	[1B,3F,n,m] H [27,63,n,m] D	<p>Re-assign graphic type for ESC K, ESC L, ESC Y, and ESC Z commands. n: specifies the former graphic type assigned by "K", "L", "Y", or "Z" m: specifies the new graphic type in table below</p> <table border="1"> <thead> <tr> <th>m</th> <th>Graphic Type</th> <th>Number of Pins</th> <th>Maximum Columns</th> <th>Horizontal Density</th> </tr> </thead> <tbody> <tr> <td>0</td> <td>Standard-density</td> <td>8</td> <td>816</td> <td>60</td> </tr> <tr> <td>1</td> <td>Double-density</td> <td>8</td> <td>1632</td> <td>120</td> </tr> <tr> <td>2</td> <td>Double-speed double-density*</td> <td>8</td> <td>1632</td> <td>120</td> </tr> <tr> <td>3</td> <td>Quadruple-density *</td> <td>8</td> <td>3264</td> <td>240</td> </tr> <tr> <td>4</td> <td>CRT I</td> <td>8</td> <td>1088</td> <td>80</td> </tr> <tr> <td>6</td> <td>CRT II</td> <td>8</td> <td>1224</td> <td>90</td> </tr> <tr> <td>32</td> <td>Standard-density</td> <td>24</td> <td>816</td> <td>60</td> </tr> <tr> <td>33</td> <td>Double-density</td> <td>24</td> <td>1632</td> <td>120</td> </tr> <tr> <td>38</td> <td>CRT III</td> <td>24</td> <td>1224</td> <td>90</td> </tr> <tr> <td>39</td> <td>Triple-density</td> <td>24</td> <td>2448</td> <td>180</td> </tr> <tr> <td>40</td> <td>Hex-density*</td> <td>24</td> <td>4896</td> <td>360</td> </tr> </tbody> </table> <p><i>Note (*)</i>: Horizontal adjacent dots can not be printed.</p>	m	Graphic Type	Number of Pins	Maximum Columns	Horizontal Density	0	Standard-density	8	816	60	1	Double-density	8	1632	120	2	Double-speed double-density*	8	1632	120	3	Quadruple-density *	8	3264	240	4	CRT I	8	1088	80	6	CRT II	8	1224	90	32	Standard-density	24	816	60	33	Double-density	24	1632	120	38	CRT III	24	1224	90	39	Triple-density	24	2448	180	40	Hex-density*	24	4896	360
m	Graphic Type	Number of Pins	Maximum Columns	Horizontal Density																																																											
0	Standard-density	8	816	60																																																											
1	Double-density	8	1632	120																																																											
2	Double-speed double-density*	8	1632	120																																																											
3	Quadruple-density *	8	3264	240																																																											
4	CRT I	8	1088	80																																																											
6	CRT II	8	1224	90																																																											
32	Standard-density	24	816	60																																																											
33	Double-density	24	1632	120																																																											
38	CRT III	24	1224	90																																																											
39	Triple-density	24	2448	180																																																											
40	Hex-density*	24	4896	360																																																											
[42]	ESC @	[1B,40] H [27,64] D	Initializes printer.																																																												
[43]	ESC A n	[1B,41,n] H [27,65,n] D	Sets line spacing to n/60" ($0 \leq n \leq 127$).																																																												
[44]	ESC B n1 n2... n16 NUL	[1B,42,n1,n2,...n16,00] H [27,66,n1,n2,...n16,0] D	Sets vertical tab positions beginning from n1 and end with NUL [00]H. n1=1 is at the second line from TOF. Downloaded data and communication buffer are not cleared. The current print line becomes the top of the form.																																																												
[45]	ESC C n	[1B,43,n] H [27,67,n] D	Sets page length in line unit ($1 \leq n \leq 127$). The current print line becomes TOF (top of form).																																																												
[46]	ESC C NUL n	[1B,43,00,n] H [27,67,0,n] D	Sets page length in inch unit ($1 \leq n \leq 22$). The current print line becomes TOF (top of form).																																																												
[47]	ESC D n1 n2...n32 NUL	[1B,44,n1,n2,...n32,00] H [27,68,n1,n2,...n32,0] D	Sets horizontal tab position ($1 \leq n \leq 255$). n indicates the number of spaces from the left margin with the character width at the command execution. n1=1 is at the second column from the left margin.																																																												
[48]	ESC E	[1B,45] H [27,69] D	Sets emphasized character mode.																																																												
[49]	ESC F	[1B,46] H [27,70] D	Cancels emphasized character mode.																																																												
[50]	ESC G	[1B,47] H [27,71] D	Sets double strike character mode.																																																												
[51]	ESC H	[1B,48]H [27,72] D	Cancels double strike character mode.																																																												
[52]	ESC J n	[1B,4A,n] H [27,74,n] D	n/180" linefeeds after printing ($0 \leq n \leq 255$).																																																												
[53]	ESC K n1 n2 data	[1B,4B,n1,n2,data] H [27,75,n1,n2,data] D	Prints the 8-pin Standard-density graphic mode. The total number of dots in the data is set by n1+n2 x 256 .																																																												
[54]	ESC L n1 n2 data	[1B,4C,n1,n2,data] H [27,76,n1,n2,data] D	Prints the 8-pin Double-density graphic mode. The total number of dots in the data is set by n1+n2 x 256 .																																																												
[55]	ESC M	[1B,4D] H [27,77] D	Selects elite (12cpi) mode. The condensed pica character (17.1 cpi) also becomes the condensed elite character (20 cpi).																																																												
[56]	ESC N n	[1B,4E,n] H [27,78,n] D	Sets skip over perforation ($1 \leq n \leq 127$). n specifies the number of lines to be skipped at the end of a page. For example: If the line spacing is 1/6 inch and the page length is 66 lines, an ESC N 6 command causes the printer to print 60 lines, then skip 6 lines. The space to be skipped is 1 inch (1/6 inch x 6).																																																												

ITEM	SYMBOL	Hexadecimal Decimal	FUNCTION																																																																																																																																																																																																																																																										
[57]	ESC O	[1B,4F] H [27,79] D	Cancels skip over perforation.																																																																																																																																																																																																																																																										
[58]	ESC P	[1B,50] H [27,80] D	Selects pica mode (10cpi). The condensed elite character (20 cpi) also becomes the condensed pica character (17.1 cpi).																																																																																																																																																																																																																																																										
[59]	ESC Q n	[1B,51,n] H [27,81,n] D	Sets right margin at the n th horizontal space in the current print mode from the left-most print position. (1≤n≤255)																																																																																																																																																																																																																																																										
[60]	ESC R n	[1B,52,n] H [27,82,n] D	Selects International character. <table border="1" style="margin-left: 20px;"> <thead> <tr> <th rowspan="2">n</th> <th rowspan="2">Country</th> <th colspan="12">Hexadecimal Character Code</th> </tr> <tr> <th>23</th> <th>24</th> <th>40</th> <th>5B</th> <th>5C</th> <th>5D</th> <th>5E</th> <th>60</th> <th>7B</th> <th>7C</th> <th>7D</th> <th>7E</th> </tr> </thead> <tbody> <tr> <td>0</td> <td>U.S.A.</td> <td>#</td> <td>\$</td> <td>@</td> <td>[</td> <td>\</td> <td>]</td> <td>^</td> <td>~</td> <td>{</td> <td> </td> <td>}</td> <td>~</td> </tr> <tr> <td>1</td> <td>FRANCE</td> <td>#</td> <td>\$</td> <td>à</td> <td>°</td> <td>ç</td> <td>§</td> <td>^</td> <td>~</td> <td>é</td> <td>ù</td> <td>è</td> <td>~</td> </tr> <tr> <td>2</td> <td>GERMANY</td> <td>#</td> <td>\$</td> <td>§</td> <td>Ä</td> <td>Ö</td> <td>Ü</td> <td>^</td> <td>~</td> <td>ä</td> <td>ö</td> <td>ü</td> <td>ß</td> </tr> <tr> <td>3</td> <td>U.K.</td> <td>£</td> <td>\$</td> <td>@</td> <td>[</td> <td>\</td> <td>]</td> <td>^</td> <td>~</td> <td>{</td> <td> </td> <td>}</td> <td>~</td> </tr> <tr> <td>4</td> <td>DENMARK</td> <td>#</td> <td>\$</td> <td>@</td> <td>Æ</td> <td>Ø</td> <td>Å</td> <td>^</td> <td>~</td> <td>æ</td> <td>ø</td> <td>å</td> <td>~</td> </tr> <tr> <td>5</td> <td>SWEDEN</td> <td>#</td> <td>€</td> <td>É</td> <td>Ä</td> <td>Ö</td> <td>Å</td> <td>Û</td> <td>é</td> <td>ä</td> <td>ö</td> <td>å</td> <td>ü</td> </tr> <tr> <td>6</td> <td>ITALY</td> <td>#</td> <td>\$</td> <td>@</td> <td>°</td> <td>\</td> <td>é</td> <td>^</td> <td>~</td> <td>ù</td> <td>à</td> <td>ò</td> <td>è</td> </tr> <tr> <td>7</td> <td>SPAIN</td> <td>h</td> <td>\$</td> <td>@</td> <td>i</td> <td>Ñ</td> <td>¿</td> <td>^</td> <td>~</td> <td>ñ</td> <td>}</td> <td>~</td> <td></td> </tr> <tr> <td>8</td> <td>JAPAN</td> <td>#</td> <td>\$</td> <td>@</td> <td>[</td> <td>¥</td> <td>]</td> <td>^</td> <td>~</td> <td>{</td> <td> </td> <td>}</td> <td>~</td> </tr> <tr> <td>9</td> <td>NORWAY</td> <td>#</td> <td>€</td> <td>É</td> <td>Æ</td> <td>Ø</td> <td>Å</td> <td>Û</td> <td>è</td> <td>æ</td> <td>ø</td> <td>å</td> <td>ü</td> </tr> <tr> <td>10</td> <td>DENMARK 2</td> <td>#</td> <td>\$</td> <td>É</td> <td>Æ</td> <td>Ø</td> <td>Å</td> <td>Û</td> <td>è</td> <td>æ</td> <td>ø</td> <td>å</td> <td>ü</td> </tr> <tr> <td>11</td> <td>SPAIN 2</td> <td>#</td> <td>\$</td> <td>á</td> <td>i</td> <td>Ñ</td> <td>¿</td> <td>é</td> <td>~</td> <td>í</td> <td>ñ</td> <td>ó</td> <td>ú</td> </tr> <tr> <td>12</td> <td>LATIN AMERICA</td> <td>#</td> <td>\$</td> <td>á</td> <td>i</td> <td>Ñ</td> <td>¿</td> <td>é</td> <td>~</td> <td>í</td> <td>ñ</td> <td>ó</td> <td>ú</td> </tr> <tr> <td>13</td> <td>KOREA</td> <td>#</td> <td>\$</td> <td>@</td> <td>[</td> <td>₩</td> <td>]</td> <td>^</td> <td>~</td> <td>{</td> <td> </td> <td>}</td> <td>~</td> </tr> <tr> <td>31</td> <td>TURKEY</td> <td>#</td> <td>ı</td> <td>İ</td> <td>Ç</td> <td>Ö</td> <td>Ş</td> <td>Û</td> <td>ğ</td> <td>ç</td> <td>ö</td> <td>ş</td> <td>ü</td> </tr> <tr> <td>64</td> <td>LEGAL</td> <td>#</td> <td>\$</td> <td>§</td> <td>°</td> <td>'</td> <td>"</td> <td>¶</td> <td>~</td> <td>©</td> <td>®</td> <td>†</td> <td>™</td> </tr> </tbody> </table> <p><i>Note:</i> n=64 is invalid when code page is selected.</p>	n	Country	Hexadecimal Character Code												23	24	40	5B	5C	5D	5E	60	7B	7C	7D	7E	0	U.S.A.	#	\$	@	[\]	^	~	{		}	~	1	FRANCE	#	\$	à	°	ç	§	^	~	é	ù	è	~	2	GERMANY	#	\$	§	Ä	Ö	Ü	^	~	ä	ö	ü	ß	3	U.K.	£	\$	@	[\]	^	~	{		}	~	4	DENMARK	#	\$	@	Æ	Ø	Å	^	~	æ	ø	å	~	5	SWEDEN	#	€	É	Ä	Ö	Å	Û	é	ä	ö	å	ü	6	ITALY	#	\$	@	°	\	é	^	~	ù	à	ò	è	7	SPAIN	h	\$	@	i	Ñ	¿	^	~	ñ	}	~		8	JAPAN	#	\$	@	[¥]	^	~	{		}	~	9	NORWAY	#	€	É	Æ	Ø	Å	Û	è	æ	ø	å	ü	10	DENMARK 2	#	\$	É	Æ	Ø	Å	Û	è	æ	ø	å	ü	11	SPAIN 2	#	\$	á	i	Ñ	¿	é	~	í	ñ	ó	ú	12	LATIN AMERICA	#	\$	á	i	Ñ	¿	é	~	í	ñ	ó	ú	13	KOREA	#	\$	@	[₩]	^	~	{		}	~	31	TURKEY	#	ı	İ	Ç	Ö	Ş	Û	ğ	ç	ö	ş	ü	64	LEGAL	#	\$	§	°	'	"	¶	~	©	®	†	™
n	Country	Hexadecimal Character Code																																																																																																																																																																																																																																																											
		23	24	40	5B	5C	5D	5E	60	7B	7C	7D	7E																																																																																																																																																																																																																																																
0	U.S.A.	#	\$	@	[\]	^	~	{		}	~																																																																																																																																																																																																																																																
1	FRANCE	#	\$	à	°	ç	§	^	~	é	ù	è	~																																																																																																																																																																																																																																																
2	GERMANY	#	\$	§	Ä	Ö	Ü	^	~	ä	ö	ü	ß																																																																																																																																																																																																																																																
3	U.K.	£	\$	@	[\]	^	~	{		}	~																																																																																																																																																																																																																																																
4	DENMARK	#	\$	@	Æ	Ø	Å	^	~	æ	ø	å	~																																																																																																																																																																																																																																																
5	SWEDEN	#	€	É	Ä	Ö	Å	Û	é	ä	ö	å	ü																																																																																																																																																																																																																																																
6	ITALY	#	\$	@	°	\	é	^	~	ù	à	ò	è																																																																																																																																																																																																																																																
7	SPAIN	h	\$	@	i	Ñ	¿	^	~	ñ	}	~																																																																																																																																																																																																																																																	
8	JAPAN	#	\$	@	[¥]	^	~	{		}	~																																																																																																																																																																																																																																																
9	NORWAY	#	€	É	Æ	Ø	Å	Û	è	æ	ø	å	ü																																																																																																																																																																																																																																																
10	DENMARK 2	#	\$	É	Æ	Ø	Å	Û	è	æ	ø	å	ü																																																																																																																																																																																																																																																
11	SPAIN 2	#	\$	á	i	Ñ	¿	é	~	í	ñ	ó	ú																																																																																																																																																																																																																																																
12	LATIN AMERICA	#	\$	á	i	Ñ	¿	é	~	í	ñ	ó	ú																																																																																																																																																																																																																																																
13	KOREA	#	\$	@	[₩]	^	~	{		}	~																																																																																																																																																																																																																																																
31	TURKEY	#	ı	İ	Ç	Ö	Ş	Û	ğ	ç	ö	ş	ü																																																																																																																																																																																																																																																
64	LEGAL	#	\$	§	°	'	"	¶	~	©	®	†	™																																																																																																																																																																																																																																																
[61]	ESC S n	[1B,53,n] H [27,83,n] D	Sets superscript or subscript character mode n=0: the superscript character mode is set n=1: the subscript character mode is set																																																																																																																																																																																																																																																										
[62]	ESC T	[1B,54] H [27,84] D	Cancels super/subscript character mode printing.																																																																																																																																																																																																																																																										
[63]	ESC U n	[1B,55,n] H [27,85,n] D	Sets or cancels unidirectional printing. n=0: the unidirectional printing is cancelled and the bidirectional or predirectional is set according to the setup options n=1: unidirectional printing is set																																																																																																																																																																																																																																																										
[64]	ESC W n	[1B,57,n] H [27,87,n] D	Sets or cancels double width character mode n=0: the double width character mode is cancelled n=1: the double width character mode is set																																																																																																																																																																																																																																																										
[65]	ESC Y n1 n2 data	[1B,59,n1,n2] H [27,89,n1,n2] D	Prints 8-pin double-speed double-density graphic mode (120dpi). The total number of dots in the data is set by n1+n2 x 256 .																																																																																																																																																																																																																																																										
[66]	ESC Z n1 n2 data	[1B,5A,n1,n2] H [27,90,n1,n2] D	Prints 8-pin quadruple-density graphic mode (240dpi). The total number of dots in the data is set by n1+n2 x 256 .																																																																																																																																																																																																																																																										
[67]	ESC \ n1 n2	[1B,5C,n1,n2] H [27,92,n1,n2] D	Sets relative dot position to the current position. The dot spacing is 1/120 inch in draft mode and 1/180 inch in LQ/proportional mode. For Example: If n1+n2 x 256 < 32768 (8000h), then move n1+n2 x 256 dots to the right. If n1+n2 x 256 ≥ 32768 , then move 65536 - {n1+n2 x 256} dots to the left from the current position.																																																																																																																																																																																																																																																										

ITEM	SYMBOL	Hexadecimal Decimal	FUNCTION
[68]	ESC a n	[1B,61,n] H [27,97,n] D	Justification mode. n=0 : left justification is set (default) n=1 : centering is set n=2 : right justification is set n=3 : full justification is set When n is other than 0 , the printer performs one linefeed after printing.
[69]	ESC b c n1 n2 ...n16 NUL	[1B,62,c,n1,n2,...,n16,00] H [27,98,c,n1,n2,...,n16,0] D	Sets vertical tab position in channels beginning from n1 and end with NUL [00]H as in ESC b command. c specifies one of channels 0 to 7 to be set.
[70]	ESC g	[1B,67] H [27,103] D	Sets 15cpi mode.
[71]	ESC j n	[1B,6A,n] H [27,106,n] D	n/180" reverse linefeed after printing (0 ≤ n ≤ 255). This command is ignored in the cut sheet feeder mode.
[72]	ESC k n	[1B,6B,n] H [27,107,n] D	Selects font type. n=00h : ROMAN is selected n=01h : SANS SERIF is selected n=02h : COURIER is selected n=03h : PRESTIGE is selected n=04h : SCRIPT is selected n=05h : OCR-B is selected n=06h : OCR-A is selected n=07h : ORATOR is selected n=08h : ORATOR-S is selected n=14h : GOTHIC is selected
[73]	ESC l n	[1B,6C,n] H [27,108,n] D	Sets left margin at the n th horizontal space in the current print mode. The left margin can be set a distance of up to 8" from the left end of the carriage.
[74]	ESC p n	[1B,70,n] H [27,112,n] D	Sets or cancels proportional mode. n=0 : the proportional mode is cancelled n=1 : the proportional mode is set
[75]	ESC q n	[1B,71,n] H [27,113,n] D	Sets character style. n=0 : plain style is set n=1 : outline style is set n=2 : shadow style is set n=3 : outline with shadow style is set
[76]	ESC t n	[1B,74,n] H [27,116,n] D	Selects character code table. n=00,30 :Selects the italic character table. n=01,31 :Selects the graphic character table. n=02,32 :Selects the downloaded character table. n=03,33 :Selects the graphic character table. If downloaded characters cannot be printed when the downloaded character table is selected, italic characters are printed. The selected character table is changed with the ETS(t command).
[77]	ESC w n	[1B,77,n] H [27,119,n] D	Sets or cancels double height character mode. n=0 : the double height character mode is cancelled n=1 : the double height character mode is set
[78]	ESC x n	[1B,78,n] H [27,120,n] D	Selects character quality. n=0 : draft character mode is set n=1 : LQ character mode is set

□ PCL mode

ITEM	SYMBOL	Hexadecimal & Decimal	FUNCTION
[1]	BEL	[07] H [7] D	Activates the bell. (Valid for PCL3+, PCL+D)
[2]	BS	[08] H [8] D	Backspace one character.
[3]	HT	[09] H [9] D	Moves to next horizontal tab.
[4]	LF	[0A] H [10] D	Linefeeds after printing.
[5]	VT	[0B] H [11] D	Linefeeds to next vertical tab position after printing.
[6]	FF	[0C] H [12] D	Form feeds after printing.
[7]	CR	[0D] H [13] D	Carriage return after printing.
[8]	SO	[0E] H [14] D	Selects secondary font.
[9]	SI	[0F] H [15] D	Selects primary font.
[10]	ESC	[1B] H [27] D	Designate start of escape sequence.
[11]	SP	[20] H [32] D	Space one character.
[12]	DEL	[7F] H [127] D	To print the ASCII DEL character.
[13]	ESC & a # C	[1B,26,61,#,43]H [27,38,97,#,67]D	Horizontal positioning by column.
[14]	ESC & a # H	[1B,26,61,#,48]H [27,38,97,#,72]D	Horizontal positioning by 1/720".
[15]	ESC & a # L	[1B,26,61,#,4C]H [27,38,97,#,76]D	Sets left margin.
[16]	ESC & a # M	[1B,26,61,#,4D]H [27,38,97,#,77]D	Sets right margin.
[17]	ESC & a # R	[1B,26,61,#,52]H [27,38,97,#,82]D	Vertical positioning by VMI.
[18]	ESC & a # V	[1B,26,61,#,56]H [27,38,97,#,86]D	Vertical positioning by 1/720".
[19]	ESC & d # D	[1B,26,64,#,44]H [27,38,100,#,68]D	Designate underline mode.
[20]	ESC & d @	[1B,26,64,40]H [27,38,100,64]D	Cancel underline mode.
[21]	ESC & k # E	[1B,26,6B,#,45]H [27,38,107,#,69]D	Designates/ Cancels the auto- cancellation of underline.
[22]	ESC & k # F	[1B,26,6B,#,46]H [27,38,107,#,70]D	Designates/ Cancels the auto- cancellation of secondary font. <i>Note:</i> If # is set to "0", current secondary font set changes automatically to primary font when vertical position changes .
[23]	ESC & k # G	[1B,26,6B,#,47]H [27,38,107,#,71]D	Designates line termination . # = 0 (30H) :CR=CR,LF=LF,FF=FF # = 1 (31H) :CR=CR+LF,LF=LF,FF=FF # = 2 (32H) :CR=CR,LF=LF+CR,FF=FF+CR # = 3 (33H) :CR=CR+LF,LF=LF+CR,FF=FF+CR
[24]	ESC & k # H	[1B,26,6B,#,48]H [27,38,107,#,72]D	Sets HMI(Horizontal motion index). - HMI is set by 1/120 inch. - HMI is defined as the distance where the print position moves when the character code is input. If # is 12, the input characters are printed in 10 cpi.
[25]	ESC & k # S	[1B,26,6B,#,53] H [27,38,107,#,83] D	Designates character spacing. - Character spacing is set. # = 0 (30H) :Normal (10 cpi) # = 1 (31H) :Double width(5 cpi) # = 2 (32H) :Compressed (16.7 cpi) # = 4 (34H) :12 cpi spacing

B. Control code summary (HP)

ITEM	SYMBOL	Hexadecimal Decimal	FUNCTION
[26]	ESC & k # W	[1B,26,6B,#,57] D [27,38,107,#,87] D	Controls print direction. (Valid for PCL3+, PCL+D) - Print direction is set as follows. # = 0 (30H) :Unidirectional Print(left to right) # = 1 (31H) :Bidirectional Print # = 2 (32H) :Pre-directional Print
[27]	ESC & 1 # A	[1B,26,6C,#,41] H [27,38,108,#,65] D	Designates paper size. - Paper size is set as follows. # = 0 (30H) :(Setting in the setup mode) # = 2 (32H) :Letter # = 3 (33H) :Legal # = 26 (32H,36H) :A4 # = 81 (38H,31H) :ENVELOP Business(Com 10)
[28]	ESC & 1 # C	[1B,26,6C,#,43] H [27,38,108,#,67] D	Sets VMI(Vertical motion index). - VMI is set by 1/48 inch. - VMI is defined as the distance where the print position moves when the LF code is input. If # is 8, the print position moves in 6 lpi vertically.
[29]	ESC & 1 # D	[1B,26,6C,#,44] H [27,38,108,#,68] D	Sets the line spacing. VMI(Vertical motion index) # = The number of LPI (lines per inch). ex. # = 8 (38H) :8 LPI
[30]	ESC & 1 # E	[1B,26,6C,#,45] H [27,38,108,#,69] D	Sets Top margin by VMI. (where # = "1 , 2 ,...") When the top margin is set, the text length to be default. In case of Skip perforation ON Text length = page length- Top margin-1/2" (Bottom margin set to 1/2") In case of Skip perforation OFF Text length = page length- Top margin (Bottom margin set to 0")
[31]	ESC & 1 # F	[1B,26,6C,#,46] H [27,38,108,#,70] D	Sets Text length. - Text length is set by line by VMI.
[32]	ESC & 1 # H	[1B,26,6C,#,48] H [27,38,108,#,72] D	Sets paper path. - The mode set as follows. # = 0 (30H) :Eject Paper # = 1 (31H) :Feed from BIN 1 # = 2 (32H) :Feed from manual insertion # = -1 (2DH,31H) :Select fanfold paper # = 8 : BIN 2 # = 9 : BIN1+2 Note: When the "NOT INSTALLED" is selected in the " SETUP #49 CSF OPTIONS" the CSF command is the same as #=0.
[33]	ESC & 1 # L data	[1B,26,6C,#,4C] H [27,38,108,#,76] D	Designates/Cancel skip perforation mode. - Paper path is set as follows. # = 0 (30H) :Cancels the mode # = 1 (31H) :Designates the mode
[34]	ESC & 1 # P	[1B,26,6C,#,50] H [27,38,108,#,80] D	Sets page length by VMI.
[35]	ESC & p # X	[1B,26,70,#,58] H [27,38,112,#,88] D	Receives data as text.
[36]	ESC & s # C	[1B,26,73,#,43] H [27,38,115,#,67] D	Designates/Cancel wraparound.. # = 0 (30H) :Designates wraparound # = 1 (31H) :Cancels wraparound

ITEM	SYMBOL	Hexadecimal Decimal	FUNCTION																																																																																
[37]	ESC (# id ESC) # id	[1B,28,#,id] H [27,40,#,id] D [1B,29,#,id] H [27,41,#,id] D	<p>Assign font to the primary/secondary font set.</p> <table border="1"> <thead> <tr> <th># id</th> <th>Font</th> <th># id</th> <th>Font</th> </tr> </thead> <tbody> <tr><td>8 U</td><td>ROMAN-8</td><td>4 S</td><td>ISO.PORTUGAL 1</td></tr> <tr><td>0 U</td><td>ASCII</td><td>2 U</td><td>ISO.IRV</td></tr> <tr><td>0 N</td><td>ECMA-94.LATIN1(ISO8859.1)</td><td>0 K</td><td>ISO14, JIS, ASCII</td></tr> <tr><td>10U</td><td>PC-8 (PC-437)</td><td>1 U</td><td>LEGAL</td></tr> <tr><td>12U</td><td>PC-850</td><td>0 L</td><td>LINE-DRAW</td></tr> <tr><td>11U</td><td>PC-8.DENMARK/NORWAY</td><td>0 M</td><td>MATH7</td></tr> <tr><td>0 S</td><td>ISO11,SWEDEN 1</td><td>0 A</td><td>MATH-SYMBOL</td></tr> <tr><td>3 S</td><td>ISO10,SWEDEN 2</td><td>0 E</td><td>ROMAN-EXTENSION</td></tr> <tr><td>0 D</td><td>ISO60,NORWAY 1</td><td>5 S</td><td>ISO84,PORTUGAL 2</td></tr> <tr><td>1 D</td><td>ISO61,NORWAY 2</td><td>6 S</td><td>ISO85,SPAIN 2</td></tr> <tr><td>1 E</td><td>ISO4,UK</td><td>80U</td><td>PC-857</td></tr> <tr><td>1 F</td><td>ISO69,FRANCE 1</td><td>93U</td><td>PC-858</td></tr> <tr><td>1 G</td><td>ISO21,GERMANY 1</td><td>81U</td><td>PC-860</td></tr> <tr><td>0 I</td><td>ISO15,ITALY</td><td>94U</td><td>PC-861</td></tr> <tr><td>2 S</td><td>ISO17,SPAIN 1</td><td>82U</td><td>PC-863</td></tr> <tr><td>0 B</td><td>LINE-DRAW</td><td>83U</td><td>PC-865</td></tr> <tr><td>0 F</td><td>ISO25,FRANCE 2</td><td>95U</td><td>BRASCII</td></tr> <tr><td>0 G</td><td>GERMAN 2</td><td>96U</td><td>ABICOMP</td></tr> <tr><td>1 S</td><td>SPAIN 3</td><td></td><td></td></tr> </tbody> </table> <p>The 12U,0F,0G,1S,1U,0M,0A,5S and 6S are available only when PCL3+ or PCL3+D modes.</p>	# id	Font	# id	Font	8 U	ROMAN-8	4 S	ISO.PORTUGAL 1	0 U	ASCII	2 U	ISO.IRV	0 N	ECMA-94.LATIN1(ISO8859.1)	0 K	ISO14, JIS, ASCII	10U	PC-8 (PC-437)	1 U	LEGAL	12U	PC-850	0 L	LINE-DRAW	11U	PC-8.DENMARK/NORWAY	0 M	MATH7	0 S	ISO11,SWEDEN 1	0 A	MATH-SYMBOL	3 S	ISO10,SWEDEN 2	0 E	ROMAN-EXTENSION	0 D	ISO60,NORWAY 1	5 S	ISO84,PORTUGAL 2	1 D	ISO61,NORWAY 2	6 S	ISO85,SPAIN 2	1 E	ISO4,UK	80U	PC-857	1 F	ISO69,FRANCE 1	93U	PC-858	1 G	ISO21,GERMANY 1	81U	PC-860	0 I	ISO15,ITALY	94U	PC-861	2 S	ISO17,SPAIN 1	82U	PC-863	0 B	LINE-DRAW	83U	PC-865	0 F	ISO25,FRANCE 2	95U	BRASCII	0 G	GERMAN 2	96U	ABICOMP	1 S	SPAIN 3		
# id	Font	# id	Font																																																																																
8 U	ROMAN-8	4 S	ISO.PORTUGAL 1																																																																																
0 U	ASCII	2 U	ISO.IRV																																																																																
0 N	ECMA-94.LATIN1(ISO8859.1)	0 K	ISO14, JIS, ASCII																																																																																
10U	PC-8 (PC-437)	1 U	LEGAL																																																																																
12U	PC-850	0 L	LINE-DRAW																																																																																
11U	PC-8.DENMARK/NORWAY	0 M	MATH7																																																																																
0 S	ISO11,SWEDEN 1	0 A	MATH-SYMBOL																																																																																
3 S	ISO10,SWEDEN 2	0 E	ROMAN-EXTENSION																																																																																
0 D	ISO60,NORWAY 1	5 S	ISO84,PORTUGAL 2																																																																																
1 D	ISO61,NORWAY 2	6 S	ISO85,SPAIN 2																																																																																
1 E	ISO4,UK	80U	PC-857																																																																																
1 F	ISO69,FRANCE 1	93U	PC-858																																																																																
1 G	ISO21,GERMANY 1	81U	PC-860																																																																																
0 I	ISO15,ITALY	94U	PC-861																																																																																
2 S	ISO17,SPAIN 1	82U	PC-863																																																																																
0 B	LINE-DRAW	83U	PC-865																																																																																
0 F	ISO25,FRANCE 2	95U	BRASCII																																																																																
0 G	GERMAN 2	96U	ABICOMP																																																																																
1 S	SPAIN 3																																																																																		
[38]	ESC (# @	[1B,28,#,40] H [27,40,#,64] D	<p>Designates primary font.</p> <p># = 0 or "1 (30H or 31H) Copy the default primary symbol set to the current primary symbol set.</p> <p># = 2 (32H) Copy the current primary symbol set to the current primary symbol set.</p> <p># = 3 (33H) Copy the default primary font to the current primary font.</p>																																																																																
[39]	ESC (0 X ESC) 0 X	[1B,28,30,58] H [27,40,48,88] D [1B,29,30,58] H [27,41,48,88] D	Assigns the download font to the current primary/secondary font.																																																																																
[40]	ESC (s # B ESC) s # B	[1B,28,73,#,42] H [27,40,115,#,66] D [1B,29,73,#,42] H [27,41,115,#,66] D	<p>Bold or emphasized.</p> <p>- Designates/ Cancels bold or emphasized attributes as follows.</p> <p># = 0 (30H) :Bold off/Emphasized off</p> <p># = 3 (33H) :Bold on /Emphasized off</p> <p># = 7 (37H) :Bold off/Emphasized on</p>																																																																																

B. Control code summary (HP)

ITEM	SYMBOL	Hexadecimal Decimal	FUNCTION
[41]	ESC (s # H ESC) s # H	[1B,28,73,#,48] H [27,40,115,#,72] D [1B,29,73,#,48] H [27,41,115,#,72] D	Sets character spacing.(# = Font pitch(CPI)) PCL mode = PCL3+, PCL3+D or PCL3 # = 5 :5 cpi (0.01≤#<5.01) # = 10 :10 cpi (5.01≤#<10.01) # = 12 :12 cpi (10.01≤#<12.01) PCL mode = PCL3+ or PCL3+D # = 15 :15 cpi (12.01≤#<15.01) # = 16.7 :16.7 cpi (15.01≤#<16.71) # = 17.1 :17.1 cpi (16.71≤#<17.11) # = 20 :20 cpi (17.11≤#<20.01) # = 24 :24 cpi (20.01≤#) PCL mode = PCL3 # = 16.7 :16.7 cpi (12.01≤#<16.71) # = 20 :20 cpi (16.71≤#)
[42]	ESC (s # P ESC) s # P	[1B,28,73,#,50] H [27,40,115,#,80] D [1B,29,73,#,50] H [27,41,115,#,80] D	Selects proportional or fixed character spacing # = 1 (31H) :Proportional pitch # = 0 (30H) :Fixed pitch
[43]	ESC (s # Q ESC) s # Q	[1B,28,73,#,51] H [27,40,115,#,81] D [1B,29,73,#,51] H [27,41,115,#,81] D	Sets Print quality. # = 0 (30H) :Draft # = 2 (32H) :Letter Quality
[44]	ESC (s # S ESC) s # S	[1B,28,73,#,53] H [27,40,115,#,83] D [1B,29,73,#,53] H [27,41,115,#,83] D	Sets italic character. # = 0 (30H) :Cancels italic character # = 1 (31H) :Designates italic character # = 2 (32H) :Designates italic character
[45]	ESC (s # T ESC) s # T	[1B,28,73,#,54] H [27,40,115,#,84] D [1B,29,73,#,54] H [27,41,115,#,84] D	Sets typeface. # = 0 (30H) LINE PRINTER DRAFT # = 3 (33H) COURIER # = 4 (34H) SANS SERIF # = 5 (35H) ROMAN # = 6 (36H) GOTHIC # = 7 (37H) SCRIPT *
[46]	ESC (s # U ESC) s # U	[1B,28,73,#,55] H [27,40,115,#,85] D [1B,29,73,#,55] H [27,41,115,#,85] D	Sets super/Sub-script. # = + 1 (2BH,31H) :Designates superscript # = 0 (30H) :Cancels super/subscript # = - 1 (2DH,31H) :Designates subscript
[47]	ESC (s # V ESC) s # V	[1B,28,73,#,56] H [27,40,115,#,86] D [1B,29,73,#,56] H [27,41,115,#,86] D	Sets character point size # = 1 , 2 (31H,32H) :Other fonts # = 8 (38H) :Micro font # = 9 (31H,32H) :Other font

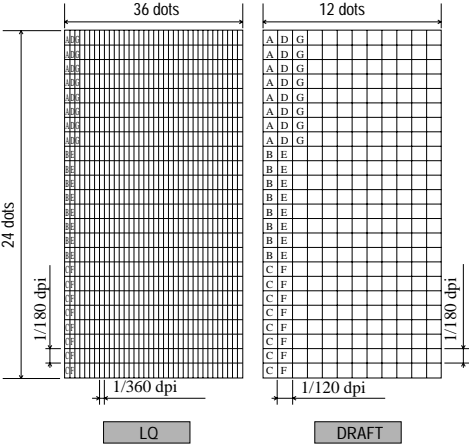
ITEM	SYMBOL	Hexadecimal Decimal	FUNCTION
[48]	ESC (s # W [data]	[1B,28,73,#,57] H [data] [27,40,115,#,87] D [data]	<p>Download character descriptor and data</p> <p>- The parameter # consists of 3 bytes of the descriptor <Attribute data format></p> <p>1 st 8 (Attribute format) 2 nd 0 (Continuation) 3 rd 1 (Acknowledge for the attribute data)</p> <p>- Dot pattern data stream is translated as follows;</p> <p style="text-align: center;">Data stream</p> <p style="text-align: center;"> </p> <p style="text-align: center;"> $\frac{1}{180}$ dpi $\frac{1}{120}$ dpi </p>  <p style="text-align: center;"> LQ DRAFT </p>
[49]	ESC) # @	[1B,29,#,40] H [27,41,#,64] D	<p>Designates secondary font.</p> <p>- The default primary font which is currently selected in the setup mode is set.</p> <p># = "0"(30H) Copy the default secondary symbol set to the current secondary symbol set.</p> <p># = "1"(31H) Copy the default primary symbol set to the current secondary symbol set.</p> <p># = "2"(32H) Copy the current primary symbol set to the current secondary symbol set.</p> <p># = "3"(33H) Copy the default secondary font to the current secondary font.</p>

ITEM	SYMBOL	Hexadecimal Decimal	FUNCTION																																																
[50]	ESC) s # W [DATA]	[1B,29,73,#,57] H DATA [27,41,115,#,87] D DATA	<p>Download font descriptor.</p> <p>- ESC) s 0 W command registers a blank LQ font.</p> <p>The format is as follows</p> <table border="1"> <tr><td>Byte 0-1</td><td>0</td><td>0</td></tr> <tr><td>Byte 2-3</td><td>0</td><td>0</td></tr> <tr><td>Byte 3-4</td><td>0</td><td>0</td></tr> <tr><td>Byte 5-6</td><td>0</td><td>0</td></tr> <tr><td>Byte 7-8</td><td>0</td><td>0</td></tr> <tr><td>Byte 9-10</td><td>0</td><td>0</td></tr> <tr><td>Byte 10-11</td><td>0</td><td>0</td></tr> <tr><td>Byte 12-13</td><td>0</td><td>0</td></tr> <tr><td>Byte 14-15</td><td colspan="2">[SYMBOL SET (2 BYTES)]</td></tr> <tr><td>Byte 16-17</td><td>0</td><td>0</td></tr> <tr><td>Byte 18-19</td><td colspan="2">[POINT SIZE (2 BYTES)]</td></tr> <tr><td>Byte 20-21</td><td>0</td><td>0</td></tr> <tr><td>Byte 22-23</td><td>0</td><td>0</td></tr> <tr><td>Byte 24-25</td><td>0</td><td>[TYPEFACE]</td></tr> <tr><td>Byte 26-27</td><td>0</td><td>0</td></tr> <tr><td>Byte 28-29</td><td>[LQ/DRAFT]</td><td>0</td></tr> </table> <p>Symbol set : Byte 14-15 represent the symbol set # and ID for the download character to be selected by [37] ESC (# id command.</p> <p>Example:Roman-8 8U” $32 \times 8 + 85 - 64 = 277$ (01H,15H)</p> <p>Point size(character height): Point size in decimal is registered.</p> <p>Typeface:Parameter used in the typeface selection command is registered.</p> <p>LQ/DRAFT:Print Quality, LQ or Draft is registered by the following definition; 0:DRAFT 1:LQ</p>	Byte 0-1	0	0	Byte 2-3	0	0	Byte 3-4	0	0	Byte 5-6	0	0	Byte 7-8	0	0	Byte 9-10	0	0	Byte 10-11	0	0	Byte 12-13	0	0	Byte 14-15	[SYMBOL SET (2 BYTES)]		Byte 16-17	0	0	Byte 18-19	[POINT SIZE (2 BYTES)]		Byte 20-21	0	0	Byte 22-23	0	0	Byte 24-25	0	[TYPEFACE]	Byte 26-27	0	0	Byte 28-29	[LQ/DRAFT]	0
Byte 0-1	0	0																																																	
Byte 2-3	0	0																																																	
Byte 3-4	0	0																																																	
Byte 5-6	0	0																																																	
Byte 7-8	0	0																																																	
Byte 9-10	0	0																																																	
Byte 10-11	0	0																																																	
Byte 12-13	0	0																																																	
Byte 14-15	[SYMBOL SET (2 BYTES)]																																																		
Byte 16-17	0	0																																																	
Byte 18-19	[POINT SIZE (2 BYTES)]																																																		
Byte 20-21	0	0																																																	
Byte 22-23	0	0																																																	
Byte 24-25	0	[TYPEFACE]																																																	
Byte 26-27	0	0																																																	
Byte 28-29	[LQ/DRAFT]	0																																																	
[51]	ESC * b # M	[1B,2A,62,#,4D] H [27,42,98,#,77] D	<p>Selects format the graphic data compression</p> <p>- Raster graphics data are registered. (Valid for PCL3+, PCL+D)</p> <p># = 0 :compression off # = 1 :mode 1 # = 2 :mode 2 # = 3 :mode 3</p>																																																
[52]	ESC * b # W [DATA]	[1B,2A,62,#,57] H DATA [27,42,98,#,87] D DATA	<p>Raster graphic data transmission</p> <p>- Raster graphics data are registered.</p>																																																
[53]	ESC * b # X	[1B,2A,62,#,58]H [27,42,98,#,88]D	Sets temporary graphics X-offset																																																
[54]	ESC * b # Y	[1B 2A 62 # 59]H [27 42 98 # 89]D	Sets temporary graphics Y-offset																																																
[55]	ESC * c # E	[1B,2A,63,#,45]H [27,42,99,#,69]D	Sets download character code																																																

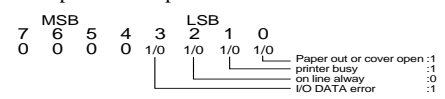
ITEM	SYMBOL	Hexadecimal Decimal	FUNCTION
[56]	ESC * c # F	[1B,2A,63,#,46]H [27,42,99,#,70]D	Download font control - Controls download font as follows. # = 0 (30H) :Delete all download font # = 3 (33H) Delete data of current download code. # = 6 (36H) :Copy ROM font to download font.
[57]	ESC * p # X	[1B,2A,70,#,58]H [27,42,112,#,88]D	Sets horizontal positioning by dot # = 1/180" units : PCL3 or PCL3+ # = 1/360" units : PCL3+ D
[58]	ESC * p # Y	[1B,2A,70,#,59]H [27,42,112,#,89]D	Sets vertical positioning by dot # = 1/180" units : PCL3 or PCL3+ # = 1/360" units : PCL3+ D
[59]	ESC * r # A	[1B,2A,72,#,41]H [27,42,114,#,65]D	Sets start raster graphics printing - Raster graphics printing starts as follows # = 0(30H) :Prints from the left most printable position # = 1(31H) :Prints from the current position
[60]	ESC * r B	[1B,2A,72,42]H [27,42,114,66]D	Sets terminates raster graphics printing - Raster graphics printing is terminated
[61]	ESC * r K	[1B,2A,72,4B]H [27,42,114,65]D	Model number request(Serial I/F only) - Model number is requested. - The printer sends back the following answer when this data is recognized. "2235A 2712CRLF"
[62]	ESC * r # S	[1B,2A,72,#,53]H [27,42,114,#,83]D	Designates raster graphics width. - Raster graphics width is defined by dot.
[63]	ESC * t # R	[1B,2A,74,#,52]H [27,42,116,#,82]D	Designates raster graphics resolution. -Raster graphics resolution is defined as follows. When PCL3+ or PCL3+D is selected. # = 6 , 0 (36H,30H) :60 dpi # = 9 , 0 (39H,30H) :90 dpi # = 1 , 8 , 0 (31H,38H,30H) :180 dpi # = 3 , 6 , 0 (33H,36H,30H) :360 dpi When PCL3 is selected. # = 9 , 0 (39H,30H) :90 dpi # = 1 , 8 , 0 (31H,38H,30H) :180 dpi
[64]	ESC 9	[1B,39]H [27,57]D	Clear left and right margin.
[65]	ESC =	[1B,3D]H [27,61]D	Half line feed -- Half line feed is executed.
[66]	ESC ? DC1	[1B,3F,11]H [27,63,17]D	Request I/O status(Serial I/O only) - Printer status is requested. - The printer sends back the following data to the host computer as the printer status. 
[67]	ESC E	[1B,45]H [27,69]D	Reset - The printer is initialized.
[68]	ESC Y	[1B, 59]H [27,89]D	Designate display function- Display function is set on.
[69]	ESC Z	[1B,5A]H [27,90]D	Cancels display function - Display function is set off.
[70]	ESC z	[1B,7A]H [27,122]D	Self test - Self test print is executed for 1 page.

□ Setup options control codes

This command is specially designed to assist you in utilizing the printer to its fullest potential. Most of printer's setup options can be accessed and changed through the following command sequence.

Setup command sequence

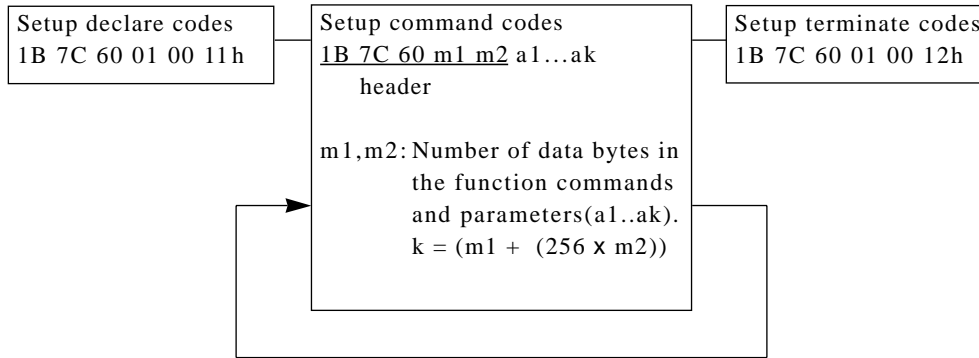

1. This command sequence is only valid when the Software setup is set to YES (enabled) in the extended options at the front control panel. The command is treated as regular print data if the Software setup is disabled.
2. Always start the software setup commands with the setup declare code and end by the setup terminate code.
3. Insert "46. Dont save" command before the setup terminate codes if the setup command sequences are used frequently. Otherwise, EEPROM ERROR may occur due to exceeding the number of the allowable write cycle of the EEPROM.

Setup command sequence

ITEM	Mode	Code & Hexadecimal	n (Hex.) = selection
[1]	Zoom in/out	Header SI n 1B, 7C, 60, 02, 00, 0F, n	n: 0 = 100% n: A = 116% n: 14 = 600% 1 = 91% B = 120% 16 = 800% 2 = 83% C = 141% 18 = 1000% 3 = 79% 10 = 200% 1A = 1200% 4 = 66% 12 = 400% 1C = 1400% 1E = 1600%
[2]	Graphic Print Mode	Header # n 1B, 7C, 60, 02, 00, 23, n	n: 0 = MODE 1 HIGH Quality Low Speed 1 = MODE 2 Normal Quality Normal Speed 2 = MODE 3 LOW Quality High Speed
[3]	Zero style	Header 0 n 1B, 7C, 60, 02, 00, 30, n	n: 0 = no slash "0" n: 1 = slashed "Ø"
[4]	Accent Character	Header 1 n 1B, 7C, 60, 02, 00, 31, n	n: 0 = SIMPLE (1PASS FONT) 1 = Comp (2PASS FONT)
[5]	FF Code at TOF	Header 2 n 1B, 7C, 60, 02, 00, 32, n	n: 0 = YES (FF Code Valid) 1 = NO (FF Code invalid)
[6]	Line spacing	Header 3 n 1B, 7C, 60, 02, 00, 33, n	n: 0 = 6 lpi n: 2 = 9 lpi n: 4 = 4 lpi 1 = 8 lpi 3 = 3 lpi

Note: The set-up declare codes will reset the printer to its default state.

ITEM	Mode	Code & Hexadecimal	n (Hex.) = selection
[7]	CR setting	Header 5 n 1B. 7C. 60. 02. 00. 35, n	n: 0 = CR only n: 2 = Autofeed 1 = CR + LF
[8]	LF setting	Header 6 n 1B. 7C. 60. 02. 00. 36, n	n: 0 = LF only 1 = CR + LF
[9]	P.out detection	Header 8 n 1B. 7C. 60. 02. 00. 38, n	n: 0 = DETECT at any position 1 = DETECT only page end
[10]	Page length lock	Header > a n 1B. 7C. 60. 03. 00. 3E, 61, n	n: 0 = No (Unlock) 1 = Yes (Lock)
[11]	Font lock	Header > b n 1B. 7C. 60. 03. 00. 3E, 62, n	n: 0 = No (Unlock) 1 = Yes (Lock)
[12]	Pitch lock	Header > c n 1B. 7C. 60. 03. 00. 3E, 63, n	n: 0 = No (Unlock) 1 = Yes (Lock)
[13]	Quality lock	Header > d n 1B. 7C. 60. 03. 00. 3E, 64, n	n: 0 = No (Unlock) 1 = Yes (Lock)
[14]	Reset key lock	Header > e n 1B. 7C. 60. 03. 00. 3E, 65, n	n: 0 = No (Unlock) 1 = Yes (Lock)
[15]	Page length	Header C m n 1B. 7C. 60. 03. 00. 43, m, n	(m=0: Fanfold) n: 0 = 11" n: 8 = 5.5" n: 10 = 9.5" n: 18 = 13.5" 1 = 2" 9 = 6" 11 = 10" 19 = 14" 2 = 2.5" A = 6.5" 12 = 10.5" 1A = 14.5 3 = 3" B = 7" 13 = 11" 1B = 15" 4 = 3.5" C = 7.5" 14 = 11.5" 1C = 15.5" 5 = 4" D = 8" 15 = 12" 1D = 16" 6 = 4.5" E = 8.5" 16 = 12.5" 1E = 16.5" 7 = 5" F = 9" 17 = 13" 20 = 12" (m=1: Single sheets paper) n: 0 = A4 portrait n: 11 = B5 landscape 1 = B5 portrait 12 = A4 landscape 2 = A4 portrait 13 = B4 landscape 3 = B4 portrait 14 = Letter landscape 4 = Letter portrait 15 = Legal landscape 5 = Legal portrait 16 = A3 landscape 6 = A3 portrait
[16]	Emulation	Header E n 1B. 7C. 60. 02. 00. 45, n	n: 0 = Epson 3 = HP 1 = IBM
[17]	Multipart	Header G n 1B. 7C. 60. 02. 00. 47, n	n: 0 = Normal n: 2 = Dark1 1 = Normal 3 = Dark2
[18]	Bottom margin	Header N n 1B. 7C. 60. 02. 00. 4E, n	n: 0 = 0 line n: 5 = 5 lines n: 10 = 10 lines 1 = 1 line 6 = 6 lines 11 = 11 lines 2 = 2 lines 7 = 7 lines 12 = 12 lines 3 = 3 lines 8 = 8 lines 13 = 13 lines 4 = 4 lines 9 = 10 lines 14 = 14 lines 15 = 15 lines
[19]	Override	Header O n 1B. 7C. 60. 02. 00. 4F, n	n: 0 = No 1 = Yes
[20]	Character spacing	Header P n 1B. 7C. 60. 02. 00. 50, n	n: 0 = 10cpi n: 5 = 20cpi 1 = 10cpi 6 = 24cpi 2 = 12cpi 7 = Proportional 3 = 15cpi 8 = 1/2 Proportional 4 = 17.1cpi 9 = 16.7cpi

B. Control code summary (Setup options)

ITEM	Mode	Code & Hexadecimal	n (Hex.) = selection
[21]	Left/right margin	(Header) Q <i>ml mr</i> <u>1B, 7C, 60, 03, 00, 51, ml, mr</u>	00 ≤ <i>ml</i> ≤ 63 Left margin 00 ≤ <i>mr</i> ≤ 63 Right margin
[22]	International character	Header R <i>n</i> <u>1B, 7C, 60, 02, 00, 52, n</u>	<i>n</i> : 0 = USA <i>n</i> : 5 = Sweden <i>n</i> : A = Denmark2 1 = France 6 = Italy B = Spain2 2 = Germany 7 = Spain C = Latin America 3 = U.K 8 = Japan D = Korea 4 = Denmark 9 = Norway E = Turkey F = Legal
[23]	Auto scroll	Header S <i>n</i> <u>1B, 7C, 60, 02, 00, 53, n</u>	<i>n</i> : 0 = No scroll <i>n</i> : 3 = 5 seconds 1 = 0.5 second 4 = 10 seconds 2 = 1 second 5 = 15 seconds
[24]	Auto scroll Valid Position	Header S [FF] <i>n</i> <u>1B, 7C, 60, 03, 00, 53, FF, n</u>	<i>n</i> : 0 = Valid at any position 1 = Valid at any TOF position
[25]	Top margin	Header T [00] <i>n</i> <u>1B, 7C, 60, 03, 00, 54, 00, n</u>	00 ≤ <i>n</i> ≤ 15
[26]	Print direction	Header U <i>n</i> <u>1B, 7C, 60, 02, 00, 55, n</u>	<i>n</i> : 0 = Pre-direction <i>n</i> : 2 = Uni-direction 1 = Pre-direction 3 = Bi-direction
[27]	Paper width	Header W <i>n</i> <u>1B, 7C, 60, 02, 00, 57, n</u>	<i>n</i> : 0 = 15 inches <i>n</i> : 2 = 5 inches 1 = 10 inches
[28]	IBM graphics AGM	Header Y <i>n</i> <u>1B, 7C, 60, 02, 00, 59, n</u>	<i>n</i> : 0 = Invalid 1 = Valid
[29]	Label mode	Header [<i>n</i> <u>1B, 7C, 60, 02, 00, 5B, n</u>	<i>n</i> : 0 = No 1 = Yes
[30]	Enlarged Character Size	Header] X <i>n</i> <u>1B, 7C, 60, 03, 00, 5D, 58, n</u>	<i>n</i> : 0 = 1 <i>n</i> : 4 = 12 1 = 2 5 = 16 2 = 4 6 = 24 3 = 8 7 = 32
[31]	Barcode/ Enlarged character command	Header] m <i>n</i> <u>1B, 7C, 60, 03, 00, 5D, 6D, n</u>	<i>n</i> : 0 = MODE2 1 = Ignored 2 = MODE1
[32]	Barcode type	Header] n <i>n</i> <u>1B, 7C, 60, 03, 00, 5D, 6E, n</u>	<i>n</i> : 0 = INDUSTRIAL 2/5 <i>n</i> : 7 = CODE 128 1 = INTRLVD 2/5 8 = EAN 8 2 = MATRIX 2/5 9 = EAN 13 3 = CODABAR 10 = UPC-A 4 = CODE 11 11 = UPC-E 5 = CODE 39 12 = POSTNET 6 = CODE 93 13 = ELEMENT

ITEM	Mode	Code & Hexadecimal	n (Hex.) = selection		
[33]	PCL Mode	Header] w n 1B, 7C, 60, 03, 00, 3C, 65, n	n: 0 = PCL3+ n: 2 = PCL3+D 1 = PCL3		
[34]	Bar Code Size	Header] x n 1B, 7C, 60, 03, 00, 5D, 78, n	n: 0 = 1 1 = 1.5 2 = 2 3 = 2.5		
[35]	Sleep Mode	Header e n 1B, 7C, 60, 03, 00, 65, n	n: 0 = Sleep Mode Valid 1 = Sleep Mode invalid		
[36]	Line feed Speed	Header f n 1B, 7C, 60, 03, 00, 66, n	n: 0 = Normal Speed 1 = Half Speed		
[37]	Code page	Header i n 1B, 7C, 60, 02, 00, 69, n	n: 0 = 437 (USA) 1 = 850 (Multi-lingual) 3 = 860 (Portuguese) 4 = 863 (Canadian-French) 5 = 865 (Nordic) 6 = 857 (Turkey) 20h = ISO-8859-1 7 = 858 8 = 861 9 = BRASCII 0A = ABICOMP		
[38]	Font select	Header k n 1B, 7C, 60, 02, 00, 6B, n	n: 0 = Roman n: 6 = OCR-B 1 = Roman 7 = OCR-A 2 = Sans Serif 8 = Gothic 3 = Courier 9 = Orator 4 = Prestige A = Orator-S 5 = Script		
[39]	Option	Header o m n 1B, 7C, 60, 03, 00, 6F, m, n	m: 0 n: 0 = CSF not installed 1 = Single bin 2 = Double bin		
[40]	TOF adjustment	Header p n1 n2 1B, 7C, 60, 03, 00, 70, n1, n2	n = n1 + 256 × n2 n/60" (0 ≤ n ≤ 480)		
[41]	Character table	Header t m n 1B, 7C, 60, 03, 00, 74, m, n	<table border="0"> <tr> <td>m: 0 = (Epson) n: 0 = Italic 1 = Graphic 2 = Download 3 = Code page</td> <td>m: 1 = (IBM) n: 0 = IBM Set 1 1 = IBM Set 2</td> </tr> </table> m: 3 = (HP)(PRIMARY FONT)] n: 0 = ROMAN-8 (8U) 1 = CODE PG CODE PAGE 2 = PC-8D/N PC-8 Denmark/Norway(11U) 3 = ECMA ECMA LATIN 1(ISO 8859-1,0N) 4 = LEGAL (HP SET,1U) 5 = SWEDEN1 (ISO-10,0S) 6 = SWEDEN2 (ISO-11,3S) 7 = SPAIN (ISO-17,2S) 8 = FRANCE (ISO-69,1F) 9 = GERMANY (ISO-21,1G) A = U.K. (ISO-4,1E) B = PORTU PORTUGAL(ISO-16,4S) C = NORWAY1 (ISO-60,0D) D = NORWAY2 (ISO-61,1D) E = IRV (ISO-2,2U)	m: 0 = (Epson) n: 0 = Italic 1 = Graphic 2 = Download 3 = Code page	m: 1 = (IBM) n: 0 = IBM Set 1 1 = IBM Set 2
m: 0 = (Epson) n: 0 = Italic 1 = Graphic 2 = Download 3 = Code page	m: 1 = (IBM) n: 0 = IBM Set 1 1 = IBM Set 2				

B. Control code summary (Setup options)

ITEM	Mode	Code & Hexadecimal	n (Hex.) = selection
			F = ITALY (ISO-15,0I) 10 = FRANC2 FRANCE 2(ISO-25,0F) 11 = GERMN2 GERMAN 2(HP SET,OG) 12 = SPAIN2 (ISO-85,6S) 13 = SPAIN3 (HP-SET,1S) 14 = JAPAN (ISO-14,0K) 15 = PORTU2 PORTUGAL(ISO-84,5S) m:4 = (HP)(SECONDARY FONT) n: 0 = LINE-DRAW (0L) 1 = MATH-7 (0M)
[42]	Tabulation	<u>Header</u> w n 1B, 7C, 60, 02, 00, 77, n	n: 0 = 2 characters n: 3 = 8 characters 1 = 4 characters 4 = 10 characters 2 = 6 characters 5 = 12 characters
[43]	Quality	<u>Header</u> x n 1B, 7C, 60, 02, 00, 78, n	n: 0 = LQ n: 4 = Draft 1 = Draft 5 = Speed draft (SD) 2 = LQ 6 = Super speed draft (SSD) 3 = NLQ 7 = HQDR
[44]	Invert display	<u>Header</u> y n 1B, 7C, 60, 02, 00, 79, n	n: 0 = No (normal) 1 = Yes (upside-down)
[45]	Display language	<u>Header</u> z n 1B, 7C, 60, 02, 00, 7A, n	n: 0 = English n: 3 = Español 1 = Deutsch 4 = Italiano 2 = Français
[46]	Dont save	<u>Header</u> [7F] 1B, 7C, 60, 01, 00, 7F	By inserting this command before the setup terminate codes, all the setup changes are not saved in the EEPROM but only in the current memory.

Appendix C. Character sets

Epson, *Italic character set*

H L	0 (0)	1 (16)	2 (32)	3 (48)	4 (64)	5 (80)	6 (96)	7 (112)	8 (128)	9 (144)	A (160)	B (176)	C (192)	D (208)	E (224)	F (240)
0	NUL		SP	0	@	P	`	p	NUL	SP	0	@	P	`	p	
1		DC1	!	1	A	Q	a	q		DC1	!	1	A	Q	a	q
2		DC2	"	2	B	R	b	r		DC2	"	2	B	R	b	r
3		DC3	#	3	C	S	c	s		DC3	#	3	C	S	c	s
4		DC4	\$	4	D	T	d	t		DC4	\$	4	D	T	d	t
5			%	5	E	U	e	u			%	5	E	U	e	u
6			&	6	F	V	f	v			&	6	F	V	f	v
7	BEL		'	7	G	W	g	w	BEL		'	7	G	W	g	w
8	BS	CAN	(8	H	X	h	x	BS	CAN	(8	H	X	h	x
9	HT	EM)	9	I	Y	i	y	HT	EM)	9	I	Y	i	y
A	LF		*	:	J	Z	j	z	LF		*	:	J	Z	j	z
B	VT	ESC	+	;	K	[k	{	VT	ESC	+	;	K	[k	{
C	FF		,	<	L	\	l		FF		,	<	L	\	l	
D	CR		-	=	M]	m	}	CR		-	=	M]	m	}
E	SO		.	>	N	^	n	~	SO		.	>	N	^	n	~
F	SI		/	?	O	_	o	DEL	SI		/	?	O	_	o	DEL

Note: This character set is selected with ESC t 0. Refer to Control code summary section.

Epson, *Graphic character set, extended*

H L	0 (0)	1 (16)	2 (32)	3 (48)	4 (64)	5 (80)	6 (96)	7 (112)	8 (128)	9 (144)	A (160)	B (176)	C (192)	D (208)	E (224)	F (240)
0	NUL		SP	0	@	P	`	p	Ç	É	á		L	ll	α	≡
1		DC1	!	1	A	Q	a	q	Û	æ	í		l	ll	β	±
2		DC2	"	2	B	R	b	r	é	Æ	ó		l	ll	Γ	≥
3		DC3	#	3	C	S	c	s	â	ô	ú		l	ll	π	≤
4		DC4	\$	4	D	T	d	t	ä	ö	ñ		l	ll	Σ	∫
5		§	%	5	E	U	e	u	à	ò	Ñ		l	ll	σ	∫
6			&	6	F	V	f	v	å	û	æ		l	ll	μ	÷
7	BEL		'	7	G	W	g	w	ç	ù	ø		l	ll	τ	≈
8	BS	CAN	(8	H	X	h	x	ê	ÿ	ç		l	ll	Φ	°
9	HT	EM)	9	I	Y	i	y	ë	Ö	ç		l	ll	Θ	•
A	LF		*	:	J	Z	j	z	è	Ü	ç		l	ll	Ω	•
B	VT	ESC	+	;	K	[k	{	ï	φ	½		l	ll	δ	√
C	FF		,	<	L	\	l		î	£	¼		l	ll	ε	n ²
D	CR		-	=	M]	m	}	ì	¥	i		l	ll	ø	2
E	SO		.	>	N	^	n	~	ï	Ä	Pt		l	ll	ε	■
F	SI		/	?	O	_	o	DEL	Å	f	»		l	ll	∩	SP

Note: This character set is selected with ESC 6 and ESC t 1. Refer to Control code summary section.

International character set (EPSON)

Country \ Hex	23	24	40	5B	5C	5D	5E	60	7B	7C	7D	7E
U.S.A.	#	\$	@	[\]	^	`	{		}	~
FRANCE	#	\$	à	°	ç	§	^	`	é	ù	è	..
GERMANY	#	\$	§	Ä	Ö	Ü	^	`	ä	ö	ü	ß
U.K.	#	\$	@	[\]	^	`	{		}	~
DENMARK	#	\$	@	Æ	Ø	Å	^	`	æ	ø	å	~
SWEDEN	#	¤	É	Ä	Ö	Å	Ü	é	ä	ö	å	ü
ITALY	#	\$	@	°	\	é	^	ù	à	ò	è	ì
SPAIN	¤	\$	@	;	Ñ	¿	^	`	..	ñ	}	~
JAPAN	#	\$	@	[¥]	^	`	{		}	~
NORWAY	#	¤	É	Æ	Ø	Å	Ü	é	æ	ø	å	ü
DENMARK 2	#	\$	É	Æ	Ø	Å	Ü	é	æ	ø	å	ü
SPAIN 2	#	\$	á	;	Ñ	¿	é	ü	í	ñ	ó	ú
LATIN AMERICA	#	\$	á	;	Ñ	¿	é	ü	í	ñ	ó	ú
KOREA	#	\$	@	[₩]	^	`	{		}	~
TURKEY	#	1	İ	Ç	Ö	Ş	Ü	ğ	ç	ö	ş	ü
LEGAL	#	\$	§	°	,	"	¶	'	©	®	†	™

Note: This character set is selected with **ESC R n** in the Epson mode or from the front control panel. Refer to Control code summary or the extended setup options.

IBM character set 1

H \ L	0	1	2	3	4	5	6	7	8	9	A	B	C	D	E	F
	(0)	(16)	(32)	(48)	(64)	(80)	(96)	(112)	(128)	(144)	(160)	(176)	(192)	(208)	(224)	(240)
0	NUL		SP	0	@	P	`	p	NUL		á	█	L	ll	α	≡
1		DC1	!	1	A	Q	a	q		DC1	í	█	l	ll	β	±
2		DC2	"	2	B	R	b	r		DC2	ó	█	l	ll	Γ	≥
3		DC3	#	3	C	S	c	s		DC3	ú	█	l	ll	π	≤
4		DC4	\$	4	D	T	d	t		DC4	ñ	█	l	ll	Σ	∫
5			%	5	E	U	e	u			Ñ	█	l	ll	σ	∫
6			&	6	F	V	f	v			æ	█	l	ll	μ	∫
7	BEL		'	7	G	W	g	w	BEL		o	█	l	ll	τ	∫
8	BS	CAN	(8	H	X	h	x	BS	CAN	¿	█	l	ll	Φ	∫
9	HT)	9	I	Y	i	y	HT		┐	█	l	ll	Θ	∫
A	LF		*	:	J	Z	j	z	LF		┘	█	l	ll	Ω	∫
B	VT	ESC	+	;	K	[k	{	VT	ESC	½	█	l	ll	δ	∫
C	PF		,	<	L	\	l		PF		¼	█	l	ll	ø	∫
D	CR		-	=	M]	m	}	CR		¾	█	l	ll	ε	∫
E	SO		.	>	N	^	n	~	SO		«	█	l	ll	∩	∫
F	SI		/	?	O	_	o		SI		»	█	l	ll	∪	∫

Note: This character set is selected with **ESC 7**. Refer to Control code summary section.

IBM character set 2

H L	0 (0)	1 (16)	2 (32)	3 (48)	4 (64)	5 (80)	6 (96)	7 (112)	8 (128)	9 (144)	A (160)	B (176)	C (192)	D (208)	E (224)	F (240)
0	NUL		SP	0	@	P	`	p	Ç	É	á		L	ll	α	≡
1		DC1	!	1	A	Q	a	q	Û	æ	í		l	ll	β	±
2		DC2	"	2	B	R	b	r	é	Æ	ó		l	ll	Γ	≥
3	♥	DC3	#	3	C	S	c	s	â	ô	ú		l	ll	π	∠
4	♦	DC4	\$	4	D	T	d	t	ä	ö	ñ		l	ll	Σ	∫
5	♣	§	%	5	E	U	e	u	à	ò	ñ		l	ll	σ	∫
6	♠		&	6	F	V	f	v	â	û	â		l	ll	μ	∫
7	BEL		'	7	G	W	g	w	ç	ù	ó		l	ll	τ	∫
8	BS	CAN	(8	H	X	h	x	ê	ÿ	ç		l	ll	Φ	∫
9	HT)	9	I	Y	i	y	ë	Ö	ü		l	ll	Θ	∫
A	LP		*	:	J	Z	j	z	è	Ü	ü		l	ll	Ω	∫
B	VT	ESC	+	;	K	[k	{	ï	φ	½		l	ll	δ	∫
C	PF		,	<	L	\	l		î	£	¼		l	ll	θ	∫
D	CR		-	=	M]	m	}	ì	¥	i		l	ll	ø	∫
E	SO		.	>	N	^	n	~	ï	Ä	Ä		l	ll	ε	∫
F	SI		/	?	O	_	o	o	Ä	f	»		l	ll	∩	∫

Note: This character set is selected with **ESC 6**. Refer to Control code summary section.

IBM all character set

H L	0 (0)	1 (16)	2 (32)	3 (48)	4 (64)	5 (80)	6 (96)	7 (112)	8 (128)	9 (144)	A (160)	B (176)	C (192)	D (208)	E (224)	F (240)
0	⊘	▶	SP	0	@	P	`	p	Ç	É	á		L	ll	α	≡
1	⊙	◀	!	1	A	Q	a	q	Û	æ	í		l	ll	β	±
2	⊕	↕	"	2	B	R	b	r	é	Æ	ó		l	ll	Γ	≥
3	♥	!!	#	3	C	S	c	s	â	ô	ú		l	ll	π	∠
4	♦	π	\$	4	D	T	d	t	ä	ö	ñ		l	ll	Σ	∫
5	♣	§	%	5	E	U	e	u	à	ò	ñ		l	ll	σ	∫
6	♠	-	&	6	F	V	f	v	â	û	â		l	ll	μ	∫
7	•	↕	'	7	G	W	g	w	ç	ù	ó		l	ll	τ	∫
8	■	↑	(8	H	X	h	x	ê	ÿ	ç		l	ll	Φ	∫
9	○	↓)	9	I	Y	i	y	ë	Ö	ü		l	ll	Θ	∫
A	⊙	→	*	:	J	Z	j	z	è	Ü	ü		l	ll	Ω	∫
B	♂	←	+	;	K	[k	{	ï	φ	½		l	ll	δ	∫
C	♀	└	,	<	L	\	l		î	£	¼		l	ll	θ	∫
D	♫	↔	-	=	M]	m	}	ì	¥	i		l	ll	ø	∫
E	♫	▲	.	>	N	^	n	~	ï	Ä	Ä		l	ll	ε	∫
F	⊛	▼	/	?	O	_	o	o	Ä	f	»		l	ll	∩	∫

Note: This character set is selected with **ESC **. Refer to Control code summary section.

C. Character Sets

HP Mode

ROMAN-8 Character sets (PCL)

L/H	0	1	2	3	4	5	6	7	8	9	A	B	C	D	E	F
0	NUL		SP	0	@	P	`	p			—	á	À	À	À	À
1		DC1	!	1	A	Q	„	q			Á	Ÿ	é	í	Ä	þ
2			”	2	B	R	b	r			Â	ÿ	ó	ø	ä	•
3		DC3	#	3	C	S	c	s			È	°	ü	Æ	Ð	μ
4			\$	4	D	T	d	t			Ê	Ç	á	á	á	¶
5			%	5	E	U	e	u			Ë	ç	é	í	í	¿
6			&	6	F	V	f	v			Ì	Ñ	ó	ø	ì	…
7	BEL		'	7	G	W	g	w			Ï	ñ	ú	æ	ó	±
8	BS		(8	H	X	h	x			ˆ	ï	ä	Ä	ò	‡
9	HT)	9	I	Y	i	y			˘	ü	è	ì	ö	•
A	LF		*	:	J	Z	j	z			˙	ü	ò	ö	ö	°
B	VT	ESC	+	;	K	[k	{			˚	ë	ú	Û	Š	«
C	FF		,	<	L	\	l				˛	ÿ	ä	É	š	■
D	CR		-	=	M]	m	}			Û	š	è	Û	Û	»
E	SO		.	>	N	^	n	~			Ü	f	ö	ß	ÿ	±
F	SI		/	?	O	_	o	DEL.			£	ø	ü	Ö	ÿ	

PC-8 (Danish / Norwegian) Character sets (PCL)

L/H	0	1	2	3	4	5	6	7	8	9	A	B	C	D	E	F
0	0	▶	SP	0	@	P	`	p	Ç	É		⌘	⌘	⌘	α	≡
1	☺	◀	!	1	A	„	:	q	ü	æ	í	⌘	⌘	⌘	β	±
2	☹	↔	”	2	B	R	b	:	é	Æ	ó	⌘	⌘	⌘	Γ	≥
3	♥	!!	#	3	C	S	c	s	ä	ó	ú		†	⌘	π	≤
4	♦	¶	\$	4	D	T	d	t	ä	ó	ñ	†	-	⌘	Σ	∫
5	♣	§	%	5	E	U	e	u	ä	ó	ñ	†	†	⌘	σ	∫
6	♠	—	&	6	F	V	f	v	ä	ú	ö	†	†	⌘	μ	÷
7	•	⌘	'	7	G	W	g	w	ç	ú	ö	⌘	⌘	⌘	τ	≈
8	☐	↑	(8	H	X	h	x	é	ÿ	ö	⌘	⌘	⌘	Φ	°
9	◊	↓)	9	I	Y	i	y	è	ö	ä	⌘	⌘	⌘	Θ	•
A	◻	→	*	:	J	Z	j	z	é	Û	Ä	⌘	⌘	⌘	Ω	•
B	♂	←	+	;	K	[k	{	ÿ	ø	ø	⌘	⌘	⌘	δ	√
C	♀	↵	,	<	L	\	l		ÿ	h	⌘	⌘	⌘	⌘	∞	n
D	♪	↔	-	=	M]	m	}	ÿ	ø	ÿ	⌘	⌘	⌘	φ	²
E	♫	▲	.	>	N	^	n	~	Ä	L	⌘	⌘	⌘	⌘	ε	■
F	♫	▼	/	?	O	_	o	DEL.	Ä	l	⌘	⌘	⌘	⌘	∩	SP

The (00)H-(1F)H and (7F)H normally function as control code.

ECMA-94 Latin 1 (ISO 8859-1)
Character sets (PCL)

L/H	0	1	2	3	4	5	6	7	8	9	A	B	C	D	E	F
0	NUL		SP	0	@	P	`	p			°	À	À	À	À	À
1		DC1	!	1	A	Q	„	q			í	±	Á	Ñ	á	ñ
2			”	2	B	R	b	r			ê	²	Â	Ò	ä	ò
3		DC3	#	3	C	S	c	s			£	³	Ã	Ó	ã	ó
4			\$	4	D	T	d	t			¤	´	Ä	Ô	ä	ô
5			%	5	E	U	e	u			¥	µ	Å	Ö	å	ö
6			&	6	F	V	f	v				¶	Æ	Ø	æ	ø
7	BEL		'	7	G	W	g	w			§	•	Ç	×	ç	÷
8	BS		(8	H	X	h	x			¨	ˆ	È	Ø	è	ø
9	HT)	9	I	Y	i	y			©	˙	É	Û	é	ù
A	LF		*	:	J	Z	j	z			ª	º	Ê	Û	ê	ú
B	VT	ESC	+	;	K	[k	{			«	»	Ë	Û	ë	û
C	FF		,	<	L	\	l				¬	‡	Ì	Û	ì	ü
D	CR		-	=	M]	m	}			¬	‡	Í	Û	í	ý
E	SO		.	>	N	^	n	~			•	‡	Î	Û	î	þ
F	SI		/	?	O	_	o	DEL.			—	˘	Ï	Û	ï	ÿ

LEGAL character sets (PCL)

L/H	0	1	2	3	4	5	6	7	8	9	A	B	C	D	E	F
0	NUL		SP	0	@	P	`	p			SP	0	@	P	`	p
1		DC1	!	1	A	Q	„	q			!	1	A	Q	„	q
2			”	2	B	R	b	r			”	2	B	R	b	r
3		DC3	#	3	C	S	c	s			#	3	C	S	c	s
4			\$	4	D	T	d	t			\$	4	D	T	d	t
5			%	5	E	U	e	u			%	5	E	U	e	u
6			&	6	F	V	f	v			&	6	F	V	f	v
7	BEL		'	7	G	W	g	w			'	7	G	W	g	w
8	BS		(8	H	X	h	x			(8	H	X	h	x
9	HT)	9	I	Y	i	y)	9	I	Y	i	y
A	LF		*	:	J	Z	j	z			*	:	J	Z	j	z
B	VT	ESC	+	;	K	[k	{			+	;	K	[k	{
C	FF		,	<	L	\	l				,	<	L	\	l	
D	CR		-	=	M]	m	}			-	=	M]	m	}
E	SO		.	>	N	^	n	~			.	>	N	^	n	~
F	SI		/	?	O	_	o	DEL.			/	?	O	_	o	DEL.

The character of (A0)H-FF are, respectively, the same as those of (20)H-(7F)H.

MATH 7 character sets (PCL)

LH	0	1	2	3	4	5	6	7	8	9	A	B	C	D	E	F
0	NUL		SP	0	π	π	π	π			SP	0	π	π	π	π
1		DC1	√	1	α	γ	α	γ			√	1	α	γ	α	γ
2				2	β	θ	β	θ				2	β	θ	β	θ
3		DC3	§	3	ψ	σ	ψ	σ			§	3	ψ	σ	ψ	σ
4			∇	4	φ	τ	φ	τ			∇	4	φ	τ	φ	τ
5			±	5	ε	ξ	ε	ξ			±	5	ε	ξ	ε	ξ
6			α	6	θ	Δ	θ	Δ			α	6	θ	Δ	θ	Δ
7	BEL		↑	7	λ	δ	λ	δ			↑	7	λ	δ	λ	δ
8	BS		÷	8	η	χ	η	χ			÷	8	η	χ	η	χ
9	HT		≈	9	ι	υ	ι	υ			≈	9	ι	υ	ι	υ
A	LF		Π	Ω	Θ	Ξ	Θ	Ξ			Π	Ω	Θ	Ξ	Θ	Ξ
B	VT	ESC	Γ	Λ	κ	↑	κ	↑			Γ	Λ	κ	↑	κ	↑
C	FF		Ψ	∞	ω	→	ω	→			Ψ	∞	ω	→	ω	→
D	CR		≡	J	μ	T	μ	T			≡	J	μ	T	μ	T
E	SO		Φ	†	ν	←	ν	←			Φ	†	ν	←	ν	←
F	SI		Ξ	Σ	ρ	↓	ρ	DEL.			Ξ	Σ	ρ	↓	ρ	DEL.

LINE DRAW character sets (PCL)

LH	0	1	2	3	4	5	6	7	8	9	A	B	C	D	E	F
0	NUL		SP	+	†	J	†	J			SP	+	†	J	†	J
1		DC1	†	†	†	†	†	†			†	†	†	†	†	†
2			†	†	†	†	†	†			†	†	†	†	†	†
3		DC3	†	†	■	†	■	†			†	†	■	†	■	†
4			†	†	■	†	■	†			†	†	■	†	■	†
5			†	†	■	†	■	†			†	†	■	†	■	†
6			†	†	†	†	†	†			†	†	†	†	†	†
7	BEL		†	†	†	†	†	†			†	†	†	†	†	†
8	BS		†	†	†	■	†	■			†	†	†	■	†	■
9	HT			=	†	†	†	†				=	†	†	†	†
A	LF		†		†	†	†	†			†		†	†	†	†
B	VT	ESC	†	†	†	†	†	†			†	†	†	†	†	†
C	FF		†	†	†	†	†	†			†	†	†	†	†	†
D	CR		L	†	†	†	†	†			L	†	†	†	†	†
E	SO			†	†	†	†	†				†	†	†	†	†
F	SI		†	†	†	†	†	DEL.			†	†	†	†	†	DEL.

The character of (A0)H-FF are, respectively, the same as those of (20)H -(7F)H.

International character set [ISO] (PCL)

	ISO	ID	23	24	40	5B	5C	5D	5E	60	7B	7C	7D	7E
ASCII	6	0U	#	\$	@	[\]	^	^	{		}	~
FRANCE	69	1F	€	€	à	·	ç	§	~	μ	é	ù	è	..
FRANCE 2	-	0F	€	\$	à	·	ç	§	~	~	é	ù	è	..
GERMANY	21	1G	#	\$	§	Ä	Ö	Ü	^	^	ä	ö	ü	ß
GERMANY 2	-	0G	€	\$	§	Ä	Ö	Ü	^	^	ä	ö	ü	ß
U.K.	4	1E	€	\$	@	[\]	^	^	{		}	—
SWEDEN	11	0S	#	□	€	Ä	Ö	Å	Ü	é	ä	ö	å	ü
SWEDEN 2	10	3S	#	□	@	Ä	Ö	Å	^	^	ä	ö	å	—
ITALY	15	0I	€	\$	§	·	ç	é	^	ù	à	ò	è	ì
SPAIN	17	2S	€	€	§	ì	Ñ	¿	^	^	·	ñ	ç	~
SPAIN 2	85	6S	#	€	·	ì	Ñ	¿	^	^	·	ñ	ç	..
SPAIN 3	-	1S	#	€	@	ì	Ñ	¿	^	^	{	ñ	}	~
JAPAN	14	0K	#	€	@	[¥]	^	^	{		}	—
NORWAY	60	0D	#	€	@	Æ	Ø	Å	^	^	æ	ø	å	—
NORWAY 2	61	1D	€	€	@	Æ	Ø	Å	^	^	æ	ø	å	
PORTUGAL	16	4S	#	€	§	Ä	Ç	Ö	^	^	ä	ç	ö	·
PORTUGAL 2	84	5S	#	€	·	Ä	Ç	Ö	^	^	ä	ç	ö	~
IRV	2	2U	#	□	@	[\]	^	^	{		}	—

- The character of (A0)H-FF are respectively, the same as those of (20)H -(7F)H.
- The characters with (20)H-(7F)H codes which are not shown in the International character set above are the same as those of (20)H -(7F)H in ROMAN-8.

Code 00H ~ 7FH (Common)

	0	1	2	3	4	5	6	7
0	Ø	▶		0	@	P	'	p
1	⊕	◀	!	1	A	Q	a	q
2	⊗	↕	"	2	B	R	b	r
3	♥	!!	#	3	C	S	c	s
4	♦	¶	\$	4	D	T	d	t
5	♣	§	%	5	E	U	e	u
6	♠	-	&	6	F	V	f	v
7	•	±	'	7	G	W	g	w
8	■	↑	(8	H	X	h	x
9	○	↓)	9	I	Y	i	y
A	◻	→	*	:	J	Z	j	z
B	♂	←	+	;	K	[k	{
C	♀	↳	,	<	L	\	l	
D	♪	↔	-	=	M]	m	}
E	♫	▲	.	>	N	^	n	~
F	*	▼	/	?	O	_	o	Δ

Code Page 437 (U.S.A.)

	8	9	A	B	C	D	E	F
0	Ç	É	á	☐	Ł	⌌	α	≡
1	ü	æ	í	☐	ł	⌌	β	±
2	é	Æ	ó	☐	Ṭ	⌌	Γ	≥
3	â	ô	ú		Ṭ	⌌	Π	≤
4	ä	ö	ñ	┆	—	⌌	Σ	∫
5	à	ò	Ñ	≡	+	⌌	σ	∫
6	ã	û	æ	≡	┆	⌌	μ	+
7	ç	ù	ó	≡	┆	⌌	τ	≈
8	è	ÿ	ı	≡	┆	⌌	Φ	°
9	ë	Ö	ı	≡	┆	⌌	Θ	•
A	è	Ü	ı	≡	┆	⌌	Ω	•
B	ï	φ	½	≡	┆	⌌	δ	√
C	î	£	¼	≡	┆	⌌	ε	n
D	ì	¥	ı	≡	┆	⌌	ø	a
E	ï	Ä	ı	≡	┆	⌌	∅	e
F	Ï	Å	f	»	┆	⌌	∅	∅

Code Page 850 (Multilingual)

	8	9	A	B	C	D	E	F
0	Ç	É	á	☐	Ł	Đ	Ó	-
1	ü	æ	í	☐	ł	Đ	ß	±
2	é	Æ	ó	☐	Ṭ	Ê	Ô	—
3	â	ô	ú		Ṭ	Ë	Ò	±
4	ä	ö	ñ	┆	—	È	ø	¶
5	à	ò	Ñ	≡	+	ı	Õ	§
6	ã	û	æ	≡	┆	İ	μ	+
7	ç	ù	ó	≡	┆	Ï	ρ	.
8	è	ÿ	ı	☐	ℒ	Ï	ρ	°
9	ë	Ö	ı	☐	ℒ	ı	Ú	•
A	è	Ü	ı	☐	ℒ	ı	Û	•
B	ï	ø	½	☐	ℒ	ı	Û	ı
C	î	£	¼	☐	ℒ	ı	Û	ı
D	ì	Ø	ı	☐	ℒ	ı	Û	ı
E	ï	Ä	ı	☐	ℒ	ı	Û	ı
F	Ï	Å	f	»	┆	ı	Û	ı

Code Page 857 (Turkish)

	8	9	A	B	C	D	E	F
0	Ç	É	á	☐	Ł	Ó	—	
1	ü	æ	í	☐	ł	ß	±	
2	é	Æ	ó	☐	Ṭ	Ê	Ô	
3	â	ô	ú		Ṭ	Ë	Ò	
4	ä	ö	ñ	┆	—	È	ø	
5	à	ò	Ñ	≡	+	ı	Õ	
6	ã	û	æ	≡	┆	İ	μ	
7	ç	ù	ó	≡	┆	Ï	ρ	
8	è	ÿ	ı	☐	ℒ	Ï	ρ	
9	ë	Ö	ı	☐	ℒ	ı	Ú	
A	è	Ü	ı	☐	ℒ	ı	Û	
B	ï	ø	½	☐	ℒ	ı	Û	
C	î	£	¼	☐	ℒ	ı	Û	
D	ì	Ø	ı	☐	ℒ	ı	Û	
E	ï	Ä	ı	☐	ℒ	ı	Û	
F	Ï	Å	f	»	┆	ı	Û	

PCL mode

The (00)H-(1F)H and (7F)H normally function as control code.

The DEL(7F)H code as "☐" character in PCL.

While TRANSPARENT mode is character font available. These characters are printable only while in TRANSPARENT mode.

EPSON/IBM mode

The (00)H-(1F)H and (80)H-(9F)H function as control codes only while in IBM character set 1 is selected.

The (03)H-(06)H,(15)H and (80)H-(9F)H are printable only while in IBM character set 2 is selected.

The all of the font table are printable only while in IBM all character set is selected.

Code Page 858 (Multilingual-Euro)

	8	9	A	B	C	D	E	F
0	Ç	É	á	▯	Ł	ø	Ó	-
1	ü	æ	í	▯	ł	Đ	ß	±
2	é	Æ	ó	▯	ł	Ê	Ô	—
3	â	ô	ú		ł	Ë	Ò	¼
4	ä	ö	ñ		ł	È	Õ	¾
5	à	ò	Ñ		ł	É	Ö	§
6	ã	û	æ		ł	Í	µ	+
7	ç	ù	ó		ł	Î	þ	.
8	ê	ÿ	ı		ł	İ	ð	°
9	ë	ÿ	ı		ł	Ï	Ú	·
A	è	Û			ł	Ů	Û	·
B	ï	ø	ı		ł	Ů	Û	·
C	î	£	ı		ł	Ÿ	Ÿ	·
D	ì	Ø	ı		ł	ı	ı	·
E	Ä	x	«		ł	ı	ı	·
F	Å	f	»		ł	ı	ı	·

Code Page 860 (Portuguese)

	8	9	A	B	C	D	E	F
0	Ç	É	á	▯	Ł	μ	α	≡
1	ü	À	í	▯	ł	π	β	±
2	é	È	ó	▯	ł	π	Γ	≥
3	â	ô	ú		ł	π	π	≤
4	ã	õ	ñ		ł	π	Σ	∩
5	à	ò	Ñ		ł	π	σ	∩
6	Á	Ú	æ		ł	π	μ	+
7	ç	ù	ó		ł	π	τ	≈
8	ê	Ì	ı		ł	π	φ	°
9	Ê	Ï	Ò		ł	π	θ	·
A	è	Û			ł	π	Ω	·
B	Í	φ	ı		ł	π	δ	√
C	Î	£	ı		ł	π	ε	n
D	ì	Ù			ł	π	ø	²
E	ã	π	«		ł	π	ε	■
F	Å	Ó	»		ł	π	∩	■

Code Page 861 (Icelandic)

	8	9	A	B	C	D	E	F
0	Ç	É	á	▯	Ł	μ	α	≡
1	ü	æ	í	▯	ł	π	β	±
2	é	Æ	ó	▯	ł	π	Γ	≥
3	â	ô	ú		ł	π	π	≤
4	ä	ö	Á		ł	π	Σ	∩
5	à	þ	Í		ł	π	σ	∩
6	ã	û	Ó		ł	π	μ	+
7	ç	Ý	Ú		ł	π	τ	≈
8	ê	ý	ı		ł	π	φ	°
9	ë	Ö			ł	π	θ	·
A	è	Û			ł	π	Ω	·
B	Ð	ø	ı		ł	π	δ	√
C	ð	£	ı		ł	π	ε	n
D	þ	Ø	ı		ł	π	ø	²
E	Ä	π	«		ł	π	e	■
F	Å	f	»		ł	π	∩	■

Code Page 863 (Canadian French)

	8	9	A	B	C	D	E	F
0	Ç	É	ı	▯	Ł	μ	α	≡
1	ü	È	ı	▯	ł	π	β	±
2	é	Ê	ó	▯	ł	π	Γ	≥
3	â	ô	ú		ł	π	π	≤
4	â	Ë	ı		ł	π	Σ	∩
5	à	Ï	ı		ł	π	σ	∩
6	ã	û	ı		ł	π	μ	+
7	ç	ù	ı		ł	π	τ	≈
8	ê	ı	ı		ł	π	φ	°
9	ë	Ï	ı		ł	π	θ	·
A	è	Û			ł	π	Ω	·
B	ï	φ	ı		ł	π	δ	√
C	î	£	ı		ł	π	ε	n
D	ı	Ù	ı		ł	π	ø	²
E	À	Ù	«		ł	π	e	■
F	Š	f	»		ł	π	∩	■

PCL mode

The (00)H-(1F)H and (7F)H normally function as control code.
The DEL(7F)H code as "▯" character in PCL.

While TRANSPARENT mode is character font available. These characters are printable only while in TRANSPARENT mode.

EPSON/IBM mode

- The (00)H-(1F)H and (80)H-(9F)H function as control codes only while in IBM character set 1 is selected.
- The (03)H-(06)H,(15)H and (80)H-(9F)H are printable only while in IBM character set 2 is selected.
- The all of the font table are printable only while in IBM all character set is selected.

Code Page 865 (Nordic)

	8	9	A	B	C	D	E	F
0	Ç	É	á	■	Ł	Ⓜ	α	≡
1	ü	æ	í	■	ł	Ⓣ	β	±
2	é	Æ	ó	■	ł	Ⓣ	Γ	≥
3	â	ô	ú		ł	Ⓣ	π	≤
4	ä	ö	ñ		ł	Ⓣ	Σ	∟
5	à	ò	Ñ		ł	Ⓣ	σ	∟
6	â	û	æ		ł	Ⓣ	μ	+
7	ç	ù	ó		ł	Ⓣ	τ	≈
8	è	ÿ	ı		ł	Ⓣ	Φ	°
9	ë	Ö	ı		ł	Ⓣ	Θ	°
A	è	Ü	ı		ł	Ⓣ	Ω	°
B	ï	ø	ı		ł	Ⓣ	δ	√
C	î	£	ı		ł	Ⓣ	ε	n
D	ì	∅	ı		ł	Ⓣ	ø	a
E	Ä	ƒ	ı		ł	Ⓣ	e	■
F	Å	f	ı		ł	Ⓣ	ñ	■

BRASCII

	8	9	A	B	C	D	E	F	
0					°	À	Ð	à	ð
1			ı	±	Á	Ñ	á	ñ	
2			ı	±	Â	Ò	â	ò	
3			ı	±	Ã	Ó	ã	ó	
4			ı	±	Ä	Ô	ä	ô	
5			ı	±	Å	Õ	å	õ	
6			ı	±	Æ	Ö	æ	ö	
7			ı	±	Ç	Ø	ç	ø	
8			ı	±	È	∅	è	ø	
9			ı	±	É	Ù	é	ù	
A			ı	±	Ê	Ú	ê	ú	
B			ı	±	Ë	Û	ë	û	
C			ı	±	Ì	Ü	ì	ü	
D			ı	±	Í	Ý	í	ý	
E			ı	±	Î	Þ	î	þ	
F			ı	±	Ï	ß	ï	ÿ	

ABICOMP

	8	9	A	B	C	D	E	F
0					Ò	ı	ò	
1			À	Ó	à	ó		
2			Á	Ô	á	ô		
3			Â	Õ	â	õ		
4			Ã	Ö	ã	ö		
5			Ä	Œ	ä	œ		
6			Ç	Ù	ç	ù		
7			È	Ú	è	ú		
8			É	Û	é	û		
9			Ê	Ü	ê	ü		
A			Ë	Ý	ë	ÿ		
B			Ì	”	ì	ß		
C			Í	£	í	æ		
D			Î	•	î	ø		
E			Ï	§	ï	ı		
F			Ñ	°	ñ	±		

ISO-1 (ISO-8859-1)

	8	9	A	B	C	D	E	F	
0					°	À	Ð	à	ð
1			ı	±	Á	Ñ	á	ñ	
2			ı	±	Â	Ò	â	ò	
3			ı	±	Ã	Ó	ã	ó	
4			ı	±	Ä	Ô	ä	ô	
5			ı	±	Å	Õ	å	õ	
6			ı	±	Æ	Ö	æ	ö	
7			ı	±	Ç	×	ç	+	
8			ı	±	È	∅	è	ø	
9			ı	±	É	Ù	é	ù	
A			ı	±	Ê	Ú	ê	ú	
B			ı	±	Ë	Û	ë	û	
C			ı	±	Ì	Ü	ì	ü	
D			ı	±	Í	Ý	í	ý	
E			ı	±	Î	Þ	î	þ	
F			ı	±	Ï	ß	ï	ÿ	

Appendix D. Reverse control panel sheet

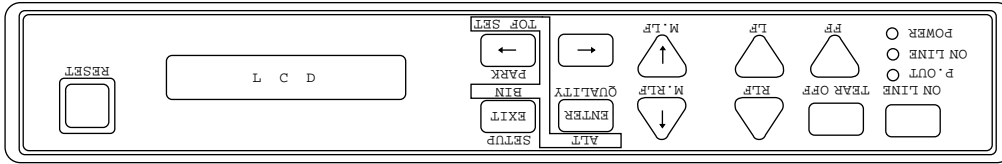

❑ Installation

The reverse control panel sheet allows you to easily read the function key labels from the back of the printer. In situations where working from the back of the printer is convenient, simply lay the reverse control panel sheet in position over the standard control panel.

Note:

If you set the invert display mode in the extended setup options, the display messages also become upside down orientation.

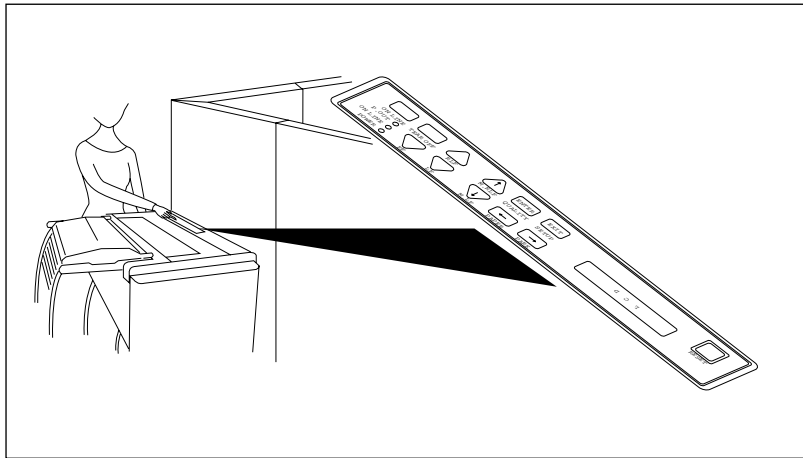

Maschinenlärminformationsverordnung 3. GSGV, 18. 01. 1991:

Der arbeitsplatzbezogene Schalldruckpegel beträgt 70 dB(A) oder weniger gemäß ISO 7779.

This unit complies with the Low Voltage Directive 73/23/EEC and the EMC Directive 89/336/EEC.

Dies Gerät entspricht den Bedingungen der Niederspannungs-Vorschrift 73/23/EEC und dem EMVG nach 89/336/EEC.

THIS DIGITAL APPARATUS DOES NOT EXCEED THE CLASS B LIMITS FOR RADIO NOISE EMISSIONS FROM DIGITAL APPARATUS AS SET OUT IN THE RADIO INTERFERENCE REGULATIONS OF THE CANADIAN DEPARTMENT OF COMMUNICATIONS.

LE PRÉSENT APPAREIL NUMÉRIQUE N' ÉMET PAS DE BRUITS RADIOÉLECTRIQUES DÉPASSANT LES LIMITES APPLICABLES AUX APPAREILS NUMÉRIQUES DE CLASSE B PRESCRITES DANS LE RÉGLEMENT SUR LE BROUILLAGE RADIOÉLECTRIQUE ÉDICTÉ PAR LE MINISTÈRE DES COMMUNICATIONS DU CANADA.

SEIKO Precision Inc.

PRINTER DIVISION

1-1-1, AKANEHAMA, NARASHINO-SHI, CHIBA 275-8558 JAPAN