

***SEKONIC***

**Super Zoom Master**

**L-608/L-608 *CINE***

**Operating Manual**

**Bedienungsanleitung**

**Mode d'emploi**

**Manuale d'istruzioni**

**Manual de instrucciones**



ENGLISH

DEUTSCH

FRANÇAIS

ITALIANO

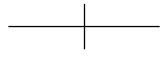
ESPAÑOL



*Congratulations on your purchase of a  
Sekonic Super Zoom Master L-608/L-608CINE  
Exposure Meter.*

ENGLISH

The Zoom Master L-608/L-608CINE is the latest addition to the extensive line of Sekonic Exposure Meters which have been market leaders.

It was designed to be the ultimate meter, a do-all instrument for the most demanding pros.

It is the first zoom spot meter on the market. Nine camera-quality lens elements are required to accomplish its 1° to 4° zoom range.

Its sealed housing and controls make it water and moisture resistant.

Yes, you can use it in the rain, but it is not an underwater meter.





Its large LCD display makes readings easy and lights up automatically in dark surroundings.

In order not to crowd the controls, four functions which are less frequently used, are confined to DIP switches, located in the battery compartment.

Because of its many features, the L-608/L-608CINE requires this rather extensive manual. But since you will never use them all at the same time, once you have learned all about it, it is simple and its use will become second nature.

The Zoom Master L-608/L-608CINE has undergone extensive quality controls at every step of manufacture. Please read this instruction manual thoroughly, to be able to take advantage of its many features and to obtain the long service life it is designed for.

Thank you for your confidence in Sekonic.



## Table of Contents

---

1. Parts Designation .....	1
2. Explanation of the Liquid Crystal Display (LCD) .....	2-3
3. Before Using .....	4-6
1. Attach the strap .....	4
2. Inserting the battery .....	4
3. Checking battery capacity .....	4
4. Replacing battery during measurement or when using the memory function .....	5
5. Auto Power Off function .....	5
6. Setting main ISO film speed .....	5
7. Setting second ISO film speed (ISO 2) .....	5
8. Measurement Lock and Measurement Lock Off .....	6
4. Basic Operation .....	7-12
1. Incident or reflected spot measuring .....	7
2. Setting measuring mode .....	8
3. Setting DIP switches .....	9
4. When set for incident light .....	10
5. When set for reflected light (spot metering) .....	11
5. Measurement .....	13-22
1. Measuring Ambient Light .....	13
1-1 Shutter Speed Priority mode .....	13
1-2 Aperture Priority mode .....	14
1-3 EV mode .....	15
1-4 Cinematography .....	16
2. Measuring Flash Light .....	18
2-1 Cord Flash mode .....	18
2-2 Auto Reset Cordless Flash mode .....	19
2-3 Cord Multiple Flash (cumulative) mode .....	21
2-4 Cordless Flash (cumulative) mode .....	22
6. Advanced Functions .....	24-35
1. Memory function .....	24
2. Averaging function .....	25
3. Brightness Difference function .....	25
4. How to use an incident Illuminance (LUX) Meter .....	27
5. How to use a reflected luminance (cd/m <sup>2</sup> ) meter .....	28
6. How to change the compensating function .....	29
7. Use of the correction indicator function .....	30
8. Filter setting .....	31
9. Analyzing measurement function .....	32
10. Custom setting function .....	33
11. Radio flash system .....	35
7. Accessories .....	38-39
8. Technical Data .....	40-41
9. Safety Guide .....	42
10. Care and Maintenance .....	43

# 1. Parts Designation

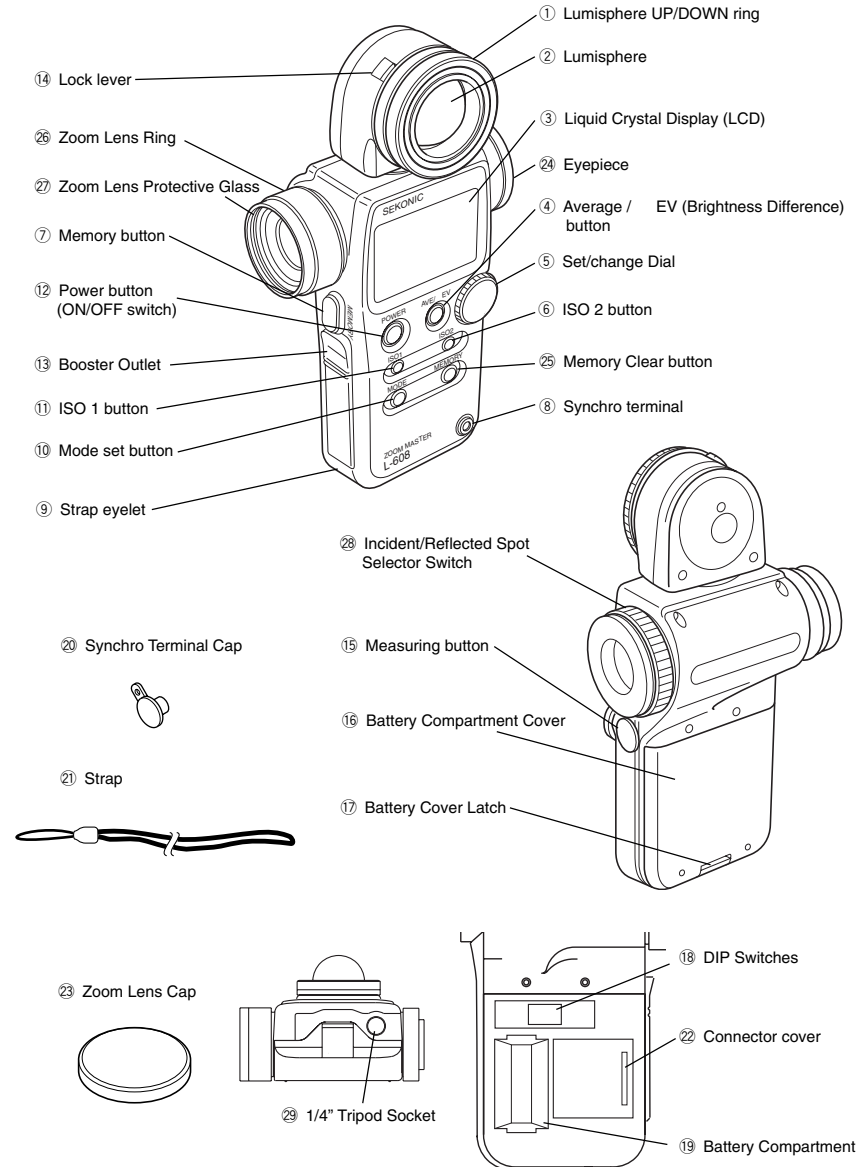

## 2. Explanation of the Liquid Crystal Display

L-608

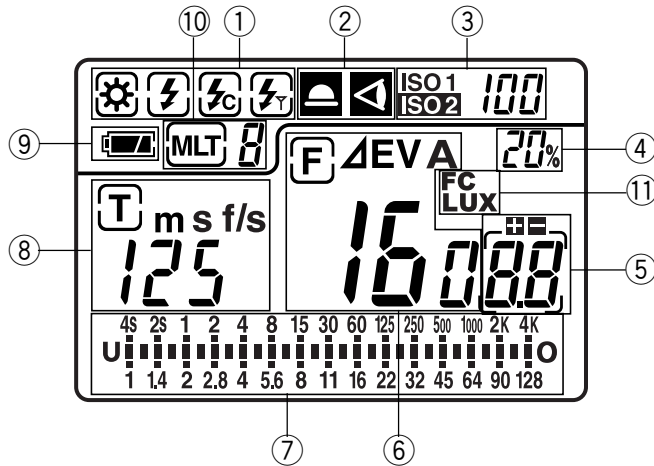

L-608CINE

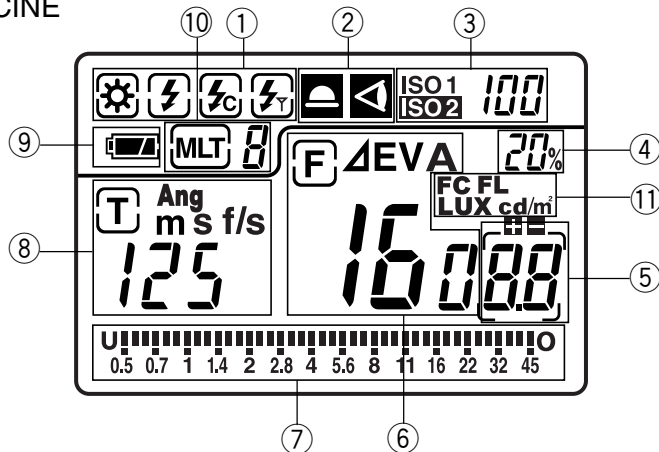

**NOTE:**

For explanation purposes, the display illustrated here shows all icons and readouts simultaneously. Actual display will never show as above.













**Auto Electro-Luminescent Display (EL)**

In low light (EV 3 or less), a blue backlight will automatically illuminate the entire LCD. When using the Mini Light Receptor or a Booster (optional accessories) the LCD will be illuminated after measuring, regardless of the ambient light level.

The LCD will not be automatically illuminated during measuring, or in Cordless Flash mode.

The Electro-luminescent backlight will automatically turn off 20 seconds after last operation.

## 2. Explanation of the Liquid Crystal Display

- ① Measuring Mode Icons
  -  Ambient (see page 13)
  -  Auto-Reset Cordless Flash (see page 19)
  -  Cord Flash (see page 18)
  -  Flash radio wave trigger mode (see page 35)
- ② Incident / Reflected Spot Function Icons (see page 7)
  -  Lights when in Incident mode
  -  Lights when in Reflected Spot mode
- ③ ISO Display
  - ISO 1** Displays ISO film setting
  - ISO 2** Displays second ISO film setting when ISO 2 button is depressed
- ④ Analyzing indicator
  - 0 to 100% in 10% increments (ratio of the flash light component to total light)
- ⑤ +/- Compensation Indicator
  -  Lights when +/- Compensation is set
- ⑥ Digital aperture value, Aperture Priority, EV Brightness Difference, Average function, EV display
  -  lights when in Aperture Priority (f/stop) mode (see page 14)
  - ΔEV** lights When Using brightness difference function (See Page 25)
  - A** lights when using Averaging function (see page 25)
  -  lights when using EV mode (see page 15)
- ⑦ Analog Aperture and Memory Scale
  - Displays marks at apertures indicating full or half f/stop values for measurement, memory, average values
  - U** lights when below display range
  -  lights when under exposed below measurement range
  - O** lights when above display range
  -  lights when over exposed above measurement range
- ⑧ Shutter priority indicator, shutter speed display for still photography or frames per second (f/s) for cinematography
  -  lights when in Shutter Priority (T) mode (see page 13)
  - m** lights when shutter speed is in minutes
  - s** lights when shutter speed is in full seconds
  - f/s** lights when shutter speed is set by number of frames (see page 16)
- ⑨ Battery Power Indicator (see page 4)
- ⑩ Memory / Multiple Flash Indicator Display
  -  lights when in Multi (cumulative) flash measurement mode (see page 21)
  - M** lights when reading is memorized (see page 24)
- ⑪ Illumination mark/brightness mark
  - Illumination with incident light (foot-candle) (608/608 Cine)
  - Brightness with incident light (lux) (608/608 Cine)
  - Illumination with reflected light (foot-lambert) (608 Cine)
  - Brightness with reflected light (cd/m<sup>2</sup>) (608 Cine)

### 3. Before Using

#### 1. Attach the strap

Attach the Strap ⑳ by passing the small end loop through the eyelet ⑨ and passing the other end of strap through it.

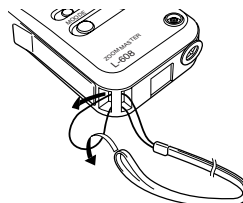

#### ⚠ WARNING

- Please place in a location where an infant cannot reach and accidentally get the strap wrapped around his neck. There is danger of strangulation.

#### 2. Inserting the battery

1. Requires one 3.0 v AA size battery. (CR123A lithium battery)
2. Open the Battery compartment cover latch ⑰, and remove the Battery compartment cover ⑱.
3. Insert the battery, observing the polarity with the +,- marks in the battery chamber.
4. Align the tabs of the Battery compartment cover with the notches in the back of the meter, and press down to close the Battery cover latch.

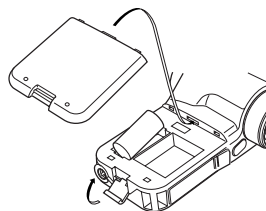

#### NOTE:

- Nickel cadmium (NiCad) and nickel hydroxide (NiH) rechargeable batteries cannot be used.
- To prevent loss of All-weather seal, be careful that dirt does not get stuck on the rubber seal and that the seal is not damaged.
- Remove battery if meter is not used for an extended period. Batteries can leak and damage the exposure meter. Dispose of used batteries properly. If the LCD does not light, check that the battery capacity is sufficient, and check that the battery positive and negative terminals are not reversed.
- The meter has a connector box for radio wave transmitter module. Remove the connector cover if you do not install radio wave transmitter module, and the electronic circuit board may be damaged by static electricity.

#### 3. Checking battery capacity

- When the Power button ⑫ is ON, the battery power indicator on the LCD is lit.



(Lit)

Battery power level is good.



(Lit)

Battery power level is low. Have a spare battery ready.



(Blinking)

Replace battery immediately.

#### Reference:

- We recommend you always have a spare battery on hand.
- If the liquid crystal display extinguishes immediately after the display appears when power is first applied, that is an indication that the battery is dead. Please promptly replace the battery.

### 3. Before Using

#### 4. Replacing battery during measurement or when using the memory function

1. Always turn the power OFF before replacing batteries. If batteries are removed with the power ON, measurements and settings in memory can no longer be recalled.
2. If after replacing the battery, or during measurements, strange screens (displays that have not been set) appear in the LCD, or nothing happens, no matter what button is pushed, remove the battery and wait at least ten seconds and then replace the battery. This allows the software to automatically reset, and is not a malfunction.

**⚠ WARNING:**

- Never place batteries in fire, short, disassemble, or heat them. The batteries might break down, and cause an accident, injury or pollute the environment.

#### 5. Auto Power Off function

1. To conserve battery power, the meter will turn off about twenty minutes after last use.
2. Whether the Auto Power Saving feature turns the power off or the Power button ⑫ is pressed, the settings and measured values remain stored in memory. When the Power button is pressed again the last settings are displayed.

Reference:

- The power shuts off automatically after 1 minute when the power button is pressed and held.

#### 6. Setting main ISO film speed

1. Hold down the ISO1 button ⑪ and turn the Set/change dial ⑤ to select ISO film speed for the film being used.
2. You can also change the ISO film speed after taking measurements. The new value is automatically displayed.

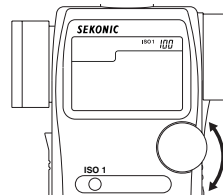

#### 7. Setting second ISO film speed (ISO 2)

1. This feature is useful when using a second film with different ISO speed, using Polaroid™ proofing film, or for exposure correction (when using a filter, close-up photography, etc.).
2. Hold down the ISO 2 button ⑬ and turn the Set/change dial to select ISO film speed of the film being used.
3. Once this is set, after taking a measurement, the measured value for the second film speed will be displayed when the ISO 2 button is depressed.
4. You can also change the second ISO film speed after taking measurements. The new value is automatically displayed.

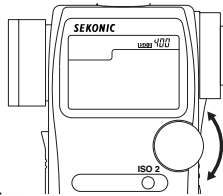

Reference:

- The following settings are possible when using custom setting function P33.
  1. It is possible to set the amount of correction within a range of  $\pm 5$  EV in 1/10 steps.
  2. When using in movie filming, it is possible to set 7 different frequently used types of filters (Kodak Wratten filters) (608 Cine compatible).



### 3. Before Using

---

#### 8. Measurement Lock and Measurement Lock Off

1. Hold down the Mode set button ⑩ and ISO1 button ⑪ and "LOC" will appear to indicate that the Measurement is locked. The last measurement is held until the lock is released, even if the Set/change dial is accidentally moved.

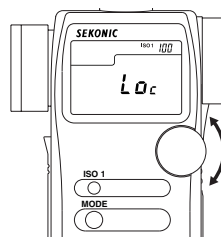

2. To release the Measurement lock, perform the same operation for the Measurement lock, Hold down the Mode set button and ISO1 button and "Off" will appear to indicate that the Measurement lock is released.

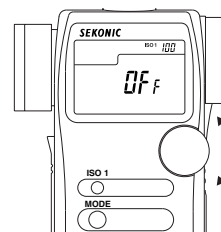

#### Reference:

- If the power supply is OFF or Auto OFF when in the locked position, the dial lock function will continue operating when the power supply is turned on next.

## 4. Basic Operation

### 1. Incident or reflected spot measuring

- To set for either incident or reflected light operation, turn the Incident / Reflected Spot Selector Switch ② on the eye piece, to the desired position (◀ or ▶ mark) until it clicks.

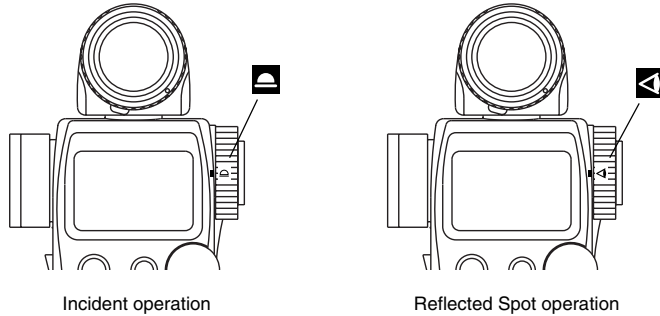

- When incident operation is selected, the ▶ mark will blink for three seconds and when Reflected Spot operation is selected the ◀ mark will blink for three seconds on the LCD.

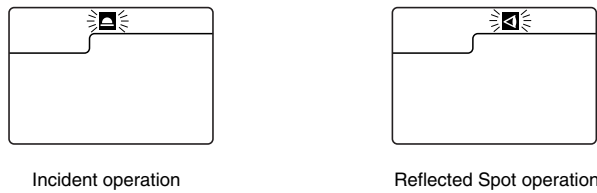

#### NOTE:

- Before taking measurements, always make sure that the desired measurement mode (▶ or ◀) is chosen by checking the LCD or that the Incident/Reflected Spot Selector Switch is clicked in proper position.

ENGLISH



## 4. Basic Operation

### 3. Setting DIP Switches

1. Switches for setting modes that are used infrequently are housed in the Battery compartment ⑱ of the meter. Select the mode you want prior to beginning measurements.
2. The DIP switches can be set by sliding the DIP switch ⑳ for the mode you want to select in the ON position.

#### EV settings

When DIP switch 1 is turned on, setting become possible for EV mode (ambient light)

#### Multi settings

When DIP switch 2 is turned on, multiple cumulative flash mode can be set.

#### Buzzer setting

When DIP switch 3 is on, the buzzer sounds when light is received in the cordless mode.

#### CS setting

When DIP switch 4 is on, the mode changes to the custom setting mode, thereby enabling various settings (refer to P33).

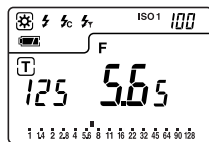
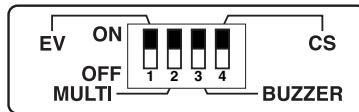

T: 1 step  
F: 1 stop

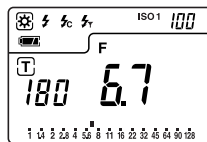

T: 1/2 step  
F: 1/2 stop

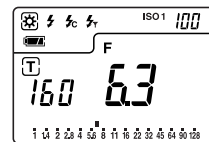

T: 1/3 step  
F: 1/3 stop

ENGLISH

## 4. Basic Operation

---

### 4. When set for incident light

1. Measurement of incident light uses Lumisphere or recessed Lumisphere. You can switch between Lumisphere and recessed function by firmly rotating the Lumisphere UP/DOWN ring ① until it clicks.

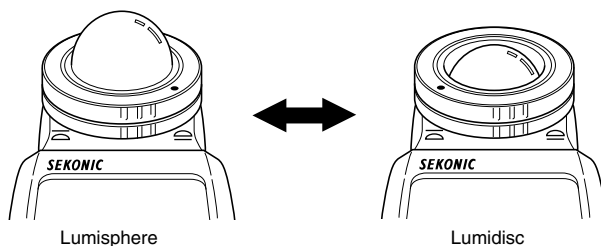



2. When the Lumisphere is raised  
This is used to photograph people, buildings, and other three dimensional objects. Measurements are basically made by the method of measuring with the lumisphere aimed in the camera direction (more precisely, in the direction of the light axis of the lens) at the position of the subject.
3. When the Lumisphere is lowered (flat diffuser function)  
This is used to photograph manuscripts, paintings or other flat copy. It can also be used for measuring illumination contrast (see page 25) or illumination levels (see page 27), or brightness difference (see page 25).

#### NOTE:

- If the device is used with the UP/DOWN ring in a middle position, distributed light quality will change, and suitable measurements cannot be made.
- Do not push the Lumisphere down manually.
- If the lumisphere becomes soiled, wipe it with a soft, dry cloth. Organic solutions (paint thinner, benzene, etc.) must not be used under any circumstances.

## 4. Basic Operation

### 5. When set for reflected light (spot metering)

1. This method measures the brightness (luminance) of the light reflected from the subject. It is useful for distant objects such as landscapes, when you cannot go to the position of the subject, or for metering subjects that generate light (neon signs, etc.), highly reflective surfaces or translucent subjects (stained glass, etc.).
2. The spot metering area can be selected by turning the Zoom Lens ring  while looking through the viewfinder from the camera position.
3. Take the measurement by aligning the circle inside the viewfinder with the subject area to be measured.
4. The black circle  in the finder indicates the measurement range. The light receiving angle is 1 degree with the telephoto setting of the zoom lens and 4 degrees with the wide angle.

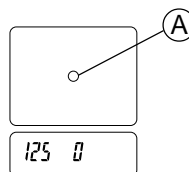
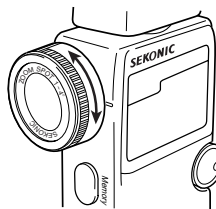

#### < Visibility Adjustment >

Turn the eyepiece and adjust the visibility so that the circle in the finder is clearly visible when you peer into the finder.

#### < Step-Up Ring > (optional)

The step-up ring (30.5mm → 40.5mm), available as an optional accessory, makes it possible to mount step rings and filters of other manufacturers. This simplifies the setting of exposure without the troublesome correction calculation of PL filters, etc.

The step-up ring can also be used as a hood to protect lenses from scratching, soiling, etc.

#### < 2x Angle Converter > (optional)

Mounting the 2x angle converter to the objective lens unit enables zoom measurements at a light receiving angle of 2° - 8°.

ENGLISH

## 4. Basic Operation

---

< Lumigrd > (opsional) (Receiving Angle 54°)

1. Remove the Lumisphere

The lumisphere unit is removed by holding the upper and lower sections of upper and lower double Lumisphere up/down ring ① and turning it in the counterclockwise direction while pushing the Lock lever upward.

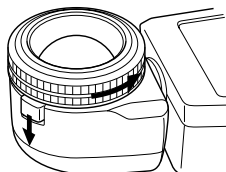

2. Mount the lumigrd

To mount Lumigrd, align the mount/removal indicator on the Lumigrd with the  mark and, while pressing it, turn it in the clockwise direction and secure it in place by raising the Lock lever until it clicks into place.

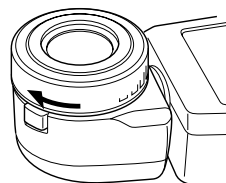

3. Take measurements by aiming the lumigrd precisely at the area of the subject to be measured from the position or direction of the camera.

4. Follow the same procedure to mount the lumisphere.

 CAUTION:

- Be sure to avoid touching the light receiving section when mounting or removing the lumisphere or lumigrd.

## 5. Measurement

### 1. Measuring ambient light

In this measurement mode, we have the choice of shutter priority mode, aperture priority mode and EV mode. Hold down the Mode set button ⑩ and turn the Set/change dial ⑤ to select ambient measurement mode ⑧.

#### 1-1 Shutter Speed Priority mode

1. Hold down the Mode set button ⑩ and turn the Set/change dial ⑤ to select shutter Speed Priority mode.
2. Turn the Set/change dial to set the desired shutter speed.
3. Press the Measuring button ⑮ to make a measurement. Release the Measuring button to complete the measurement. The measured value (aperture value) at that time will be displayed.

While pressing the Measuring button, the meter measures continuously until it is released.

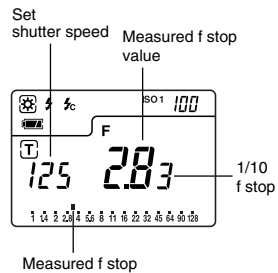
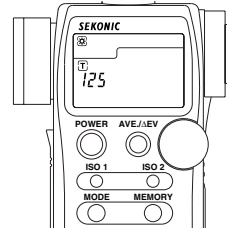

#### Reference:

- It is possible to switch between 1, 1/2 and 1/3 shutter speed steps by setting DIP switch 4.
- You can set shutter speeds from 30 minutes to 1/8000 seconds. After 1/8000 the shutter speeds of 1/200 and 1/400 can be set.
- After measurement, the F stop value corresponding to the shutter speed is displayed when the shutter speed is changed.
- The measured F value is displayed in 1/2 stops in the liquid crystal dot display (1/3 stops are not displayed). 608 Cine displays values in 1/3 stops only.
- "E.u" (Exposure under) or "E.o" (Exposure over) appears when the combination of shutter speed and aperture is not possible for the measured light level. Changing the shutter speed and or aperture with the Set/change dial will allow you to find a combination that is possible. The 'E.o' or 'E.u' mark may be displayed at the maximum and minimum F values, F45 and F0.5, respectively, with the 608 Cine.
- If the "E.u" or "E.o" readout blinks, this indicates that the light level is beyond the measurement range of the light meter.

ENGLISH



## 5. Measurement

### 1-2 Aperture Priority mode

1. Hold down the Mode set button (10) and turn the Set/change dial to select aperture priority mode.
2. Turn the Set/change dial (5) to set the desired f stop value.

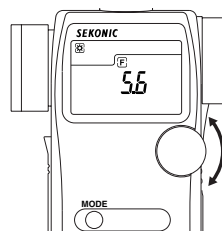

3. Press the Measuring button (15) to make a measurement. Release the Measuring button to complete the measurement. The measured value (shutter speed) at the time will be displayed.

While pressing the Measuring button, the meter measures continuously until it is released.

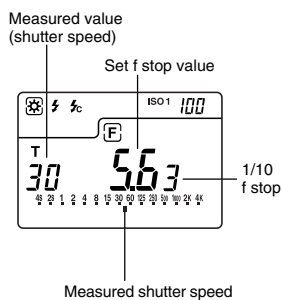

#### Reference:

- It is possible to switch between 1, 1/2 or 1/3 F stop values by setting DIP switch 4.
- You can set f stops from F0.5 to F161 (full f stops)
- The measured shutter speed is displayed in 1/2 stops in the liquid crystal dot display. With the 608 Cine, values are displayed in 1/3 stops.
- After measurement, the shutter speed corresponding to the F stop is displayed when the F stop is changed.

## 5. Measurement

### 1-3 EV mode

Open the Battery compartment cover ⑯ and slide the EV, DIP switch (see page 9) to the ON position.

1. Hold down the Mode set button ⑩ and turn the Set/change dial ⑤ to select EV value mode.

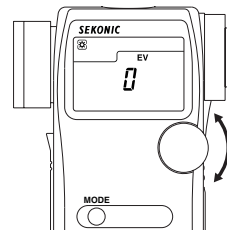

ENGLISH

2. Press the Measuring button ⑮ to make a measurement. Release the Measuring button to complete the measurement. The measured value (EV value) at that time will be displayed.

At the same time, the shutter speed will be displayed in the digital display area, and the corresponding f stop will be displayed in the analog display area.

While pressing the measuring button, the meter measures continuously until it is released.

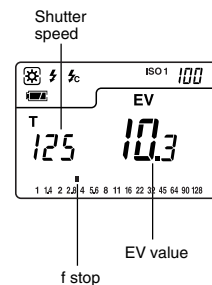

#### Reference:

- “E.u” (Exposure under) or “E.o” (Exposure over) appears when the combination of shutter speed and aperture is not possible for the measured light level. Changing the shutter speed and or aperture with the Set/change dial will allow you to find a combination that is possible. If the “E.u” or “E.o” readout blinks, this indicates that the light level is beyond of the measurement range of the light meter.

## 5. Measurement

### 1-4 Cinematography

1. Hold down the Mode set button ⑩ and turn the Set/change dial ⑤ to select ambient light shutter speed priority mode.

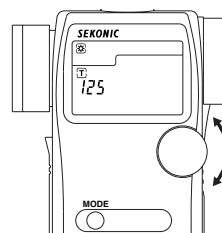

2. Turn the Set/change dial to select the Cine Speed for the camera that will be used.  
Cine Speed is displayed after 1/8000, 1/200, 1/400 and the unit are in frames per second (FPS).

[L-608]

The following Cine Speeds will display: 2, 3, 4, 6, 8, 12, 16, 18, 24, 25, 30, 32, 36, 40, 48, 50, 60, 64, 72, 96, 120, 128, 150, 200, 240, 256, 300 and 360 FPS.

[L-608CINE]

The following Cine Speeds will display: 1, 2, 3, 4, 6, 8, 12, 16, 18, 24, 25, 30, 32, 36, 40, 48, 50, 60, 64, 72, 75, 90, 96, 100, 120, 125, 128, 150, 200, 240, 250, 256, 300, 360, 375, 500, 625, 750 and 1000 FPS.

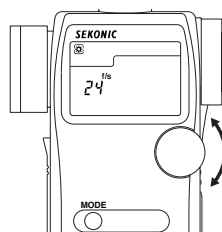

3. The shutter opening angle that these speeds are based on, is 180 degrees. For other angles make the following ISO film speed corrections.

Shutter open angle	Amount of ISO film speed correction
160 degrees	-1/3
220 degrees	+1/3

## 5. Measurement

### Example of correction value

- 1/3: Decrease ISO film speed by 1/3 stop, example: ISO 80 -1/3 stop = ISO 64
- +1/3: Increase ISO film speed by 1/3 stop, example: ISO 80 +1/3 stop = ISO 100

4. Press the Measuring button  $\text{M}$  to make a measurement. Release the Measuring button to complete the measurement. The measured value (f stop value) will be displayed.

While pressing the measuring button, the meter measures continuously until it is released.

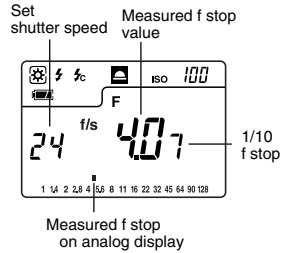

ENGLISH

### Reference:

- The measured F stop value is displayed in 1/2 stops in the liquid crystal dot display. With the 608 Cine, values are displayed in 1/3 stops.

5. Setting the shutter opening angle (608 Cine)

It is possible to set the shutter to the desired opening angle by turning the Set/change dial while pressing mode set button  $\text{M}$  and ISO2 button  $\text{ISO2}$ .

### Note:

- Shutter opening angle: The angle can be set in the range of 5° - 270° (in 5° steps) as well as 144° and 172°.
- "Ang" is displayed continuously in the LCD display if the shutter opening angle is set to any value other than 180°.
- Press the mode set button and ISO2 button to confirm the shutter opening angle if it is not continuously displayed.

### Reference:

- This setting is only valid when the shutter speed is set to display cine frame count (F/S) in the cine mode.

## 5. Measurement

### 2. Measuring flash light

This method of measurement can be done in the following modes; with cord, without cord, multiple flash with cord, multiple flash without cord and radio flash system (with optional radio transmitter module). When Measuring flash light, the shutter speed and F stop value (value combining ambient light and flash light: total amount of light) are displayed in the liquid crystal display and the ambient light and flash light are each displayed as separate values together with the total amount of light in the dot display. In addition, the ratio of flash light to the total amount of light is displayed at that time as a value in 10% steps.

#### 2-1 Cord Flash mode

The most positive method to assure proper synchronization and measurement of flash units. Connect the meter with the flash with a synchronization cord. Be sure to replace Synchro terminal cap ⑳ after your measurement.

1. Connect the flash synchro cord to the Synchro terminal ⑧ on the exposure meter.

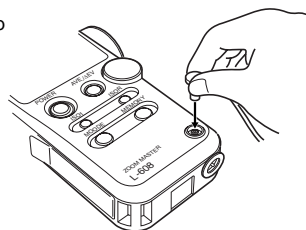

2. Hold down the Mode set button ⑩ and turn the Set/change dial ⑤ to select flash measurement with cord mode.

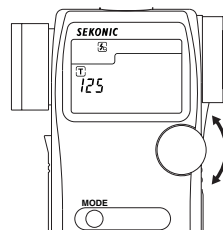

3. Turn the Set/change dial to set shutter speed. When setting shutter speed, first check the settings to confirm that they correspond to the settings on the camera.

4. Press the Measuring button ⑮ to trigger the flash. The measured value (f stop value) will be displayed.

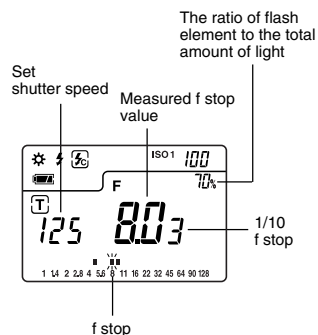

## 5. Measurement

### ⚠ CAUTION:

- There is danger of electric shock if the meter is handled with wet hands, during rain, in areas splashed by water or where there is a lot of moisture, if you use cord synchronized flash.
- Under such conditions, it is recommended that you use the meter in the flash cordless mode or radio flash system (accessories), and keep the Synchro terminal cap in place.

### NOTE:

- The electronic fire unit may fire when you connect the Synchro cord or operate the POWER Switch.
- For flash units with extremely low electric trigger voltage, the flash may not fire. In this case, make measurements in flash mode without cord (see page 19).

### Reference:

- It is possible to switch the shutter speed between 1 step, 1/2 steps and 1/3 steps by custom setting the DIP switch 4 (refer to P33).
- The shutter speed can be set in single or half steps from 30 minutes to 1/1000 of a second. After 1/1000 sec, the meter can be set at the following intermediate speeds: 1/75, 1/80, 1/90, 1/100, 1/200, or 1/400.
- If the film speed is changed after the measurement is taken, the new converted measured value (f stop value) will be displayed.
- After measurement, the F stop value corresponding to the shutter speed is displayed when the shutter speed is changed.
- "E.u" (Exposure under) or "E.o" (Exposure over) appears when the combination of shutter speed and aperture is not possible for the measured light level. Change the shutter speed with the Set/change dial and take measurements again.
- If the "E.u" or "E.o" readout blinks, this indicates that the light level is beyond of the measurement range of the light meter.

### 2-2 Auto-reset cordless flash mode

Measurements are made by the meter receiving the light from the flash. This measurement mode is used when the Synchro cord will not reach because of the distance between the flash and meter or when use of the Synchro cord is inconvenient.

1. Hold down the Mode set button ⑩ and turn the Set/Change dial ⑤ to set Auto-reset Cordless Flash mode ②.
2. Turn the Set/change dial to set shutter speed. When setting shutter speed, first check the settings to confirm that they correspond to the settings available on the camera.

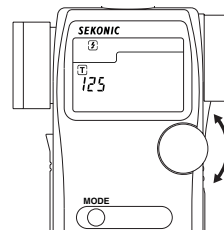

ENGLISH

## 5. Measurement

- When the Measuring button (15) is pressed, the mode mark (F) will blink and the meter is ready to measure. The ready to measure mode will continue for approximately 90 seconds. During this time, fire the flash and make a measurement.

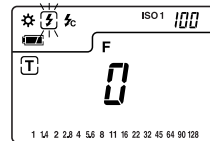

- If the 90 second period is exceeded and the blinking mark stops, press the Measuring button again to return to ready to measure.

- When the light from the flash is received, the measured value (f stop) is displayed. Even after measurement, the mode mark (F) continues to blink and the meter is in ready state and new measurement can be made. (Auto-reset function)

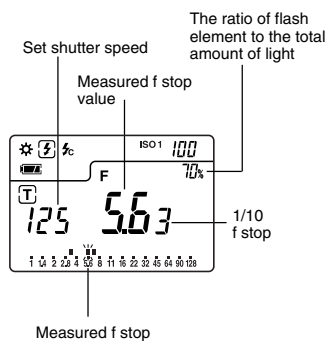

### NOTES:

- When firing a flash, if the flash brightness is low compared to the ambient light, the meter may fail to detect the light. In this case, make measurements using the flash with cord mode.
- Rapid start fluorescent lamps and special lighting are sometimes mistaken for flash, and accidentally measured. In this case, make measurements using the flash with cord mode.
- The meter's tripod socket permits mounting it to a tripod or light stand and placing it strategically when using cordless flash mode.

### Reference:

- After measurement, the F stop value corresponding to the shutter speed is displayed when the shutter speed is changed.
- Setting the shutter speed is the same as measurement (see page 18) of "Cord flash mode" of section 2-1.
- A new converted value is displayed when the film speed is changed after taking the measurement.
- Readings over and under the measuring range are the same as measurement (see page 18) of "Cord Flash mode" of section 2-1.

## 5. Measurement

### 2-3 Cord multiple flash (cumulative) mode

These measurements are used when the light generated by the flash is inadequate for proper exposure. The repeated flash pops can be accumulated until the desired aperture is displayed. The cumulative number is infinite. Only one digit is displayed if the cumulative number is ten or more.

- Slide DIP switch 2 to MULTI (see page 9) to the ON position.  
Hold down the Mode set button ⑩ and turn the Set/change dial ⑤ to select cord multiple flash (cumulative) mode (MLT will display on the LCD).

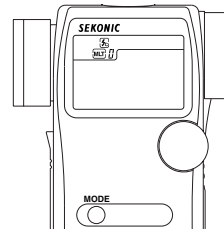

ENGLISH

- Turn the Set/change dial ⑤ to set shutter speed. When setting shutter speed, first check the settings to confirm that they correspond to the settings available on the camera.
- Connect the Flash synchro cord to the meter's synchro terminal ⑧.

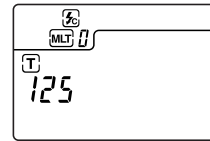

- Press the Measuring button ⑮ to trigger a flash. The measured f stop value at that time will be displayed. Each time this is repeated, the accumulated f stop value and the number of cumulative flashes is displayed.

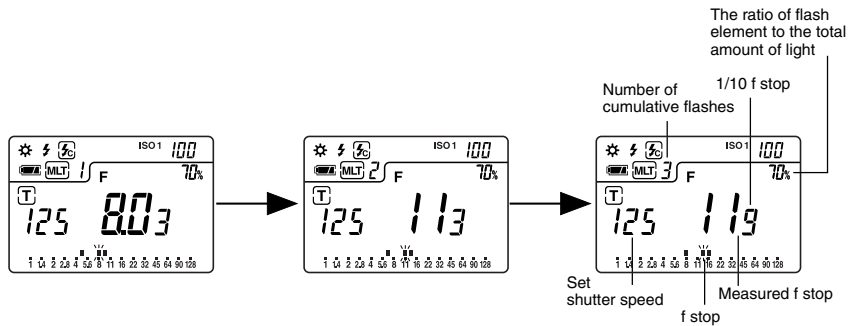

- To release the cumulative mode, switch to another mode by turning the Set/change dial while pressing the mode set button.



## 5. Measurement

### CAUTION:

- There is danger of electric shock if the meter is handled with wet hands, during rain, in areas splashed by water or where there is a lot of moisture. Under such conditions, it is recommended that you use the meter in the flash cordless mode, and keep the Synchro terminal cap in place.

### NOTE:



- The flash unit may flash when you connect the synchro cord or operate the POWER switch.
- When firing a flash to make measurements, check the camera's synchronizing range and set the proper shutter speed.
- For flash units with low electric trigger voltage, the flash may not fire. In this case, make measurements in flash mode without cord (see page 22).
- A new converted f stop is displayed when the film speed is changed after taking the measurement.

### Reference:

- Setting the shutter speed as measurement (see page 18) of "Cord flash mode" of Section 2-1.
- Readings over and under the measuring range, are the same as measurement (see page 18) of "Cord flash mode" of section 2-1.
- If the film speed is changed after the measurement is taken, the new converted measured value (f stop value) will be displayed.

### 2-4 Cordless flash (cumulative) mode

These measurements are used when the light generated by the flash is inadequate for proper exposure. The repeated flash pops can be accumulated until the desired aperture is displayed. The cumulative number is infinite. Only one digit is displayed if the cumulative number is ten or more.

1. Slide DIP switch 2 to MULTI (see page 9) to the ON position.
2. Hold down the Mode set button  and turn the Set/change dial  to select flash measurement cordless multiple flash (cumulative) mode. (MLT will display on the LCD). Turn the Set/change dial to set shutter speed. When setting shutter speed, first change the settings to confirm that they correspond to the settings available on the camera.

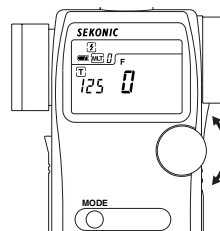

## 5. Measurement

- When the light from the flash is received, the measured value (f stop) is displayed. Each time this is repeated, the accumulated value for the aperture and the number of cumulative flashes is displayed.

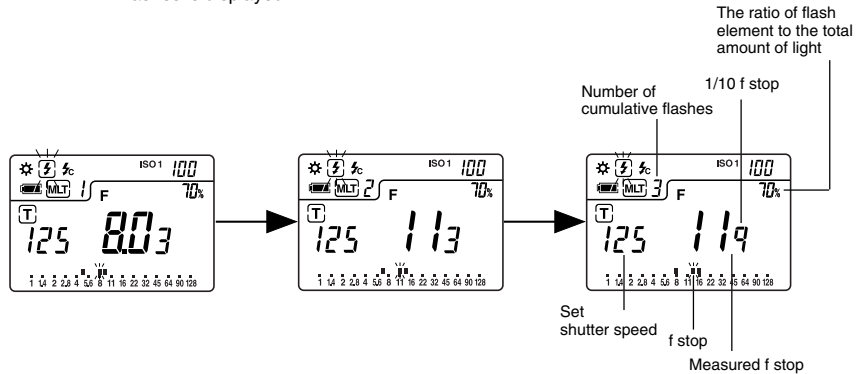

ENGLISH

- The ready to measure mode will be displayed for approximately 90 seconds. If the 90 second period is exceeded and the blinking mark stops, press the Measuring button (15) again. The measured value (f stop) of the previous time reverts to 0 and the meter is in ready to measure mode.
- If the flashing light extinguishes after 90 seconds, press the measurement button again to re-set previous setting values (F values) to "0" and revert to the standby state.

### NOTE:

- When firing a flash, if the flash brightness is low compared to the ambient light, the meter may fail to detect the light. In this case, make measurements using the flash with cord flash mode.
- Rapid start fluorescent lamps and special lighting are sometimes mistaken for flash, and accidentally measured. In this case, make measurements using the flash with cord flash mode.

### Reference:

- Setting the shutter speed is the same as measurement (see page 18) of "Cord flash mode" of Section 2-1.
- "E.u" (Exposure under) or "E.o" (Exposure over) appears when the combination of shutter speed and aperture is not possible for the measured light level. Change the shutter speed with the Set/change dial and take measurements again.
- If the "E.u" or "E.o" readout blinks, this indicates that the light level is beyond of the measurement range of the light meter.

## 6. Advanced Functions

### 1. Memory function

This meter can store up to nine measured values in memory. This feature can be used in the following modes: ambient light (shutter speed priority, aperture priority and EV) flash (with, without cord and radio wave).

1. Press the Measuring button (15) and take a measurement.
2. Press the Memory button (7) placing the measured value in memory.  
The number of values in memory is displayed on the LCD. The f stop value corresponding to the measured value is displayed in the analog section. By repeating this operation, up to nine values can be stored in memory.

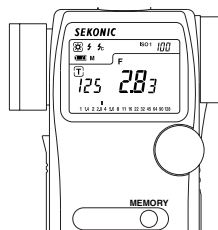

3. To release the memory, press the memory clear button (25) or switch to the measurement mode.
4. Memory Recall  
When the Set/Change dial (5) is rotated while both Memory button (7) and the Mode set button (10) are held down together, the measured value stored in the memory is displayed along with the memory number. When any stored values other than the one with the largest memory number is being recalled, its memory number appears flickering together with "M".

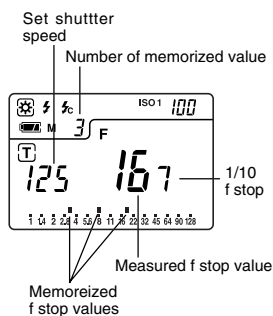

#### NOTE:

- The memory function cannot be used in "flash cumulative mode."
- Measured values for the ninth and subsequent times will be displayed but cannot be stored in memory.

## 6. Advanced Functions

### 2. Averaging function

This displays the average of two to nine of the values in memory.

1. Press the Measuring button ⑮ and take a measurement.
2. Press the Memory button ⑦ placing the measured value in memory.
3. When the Ave/ EV button ④ is pressed, an average value for the two to nine measurements display on the LCD. The value in memory and the average values are displayed on the analog scale. An "A" appears in LCD to indicate this is an average.
4. The average mode can be canceled by pressing the Ave/ EV button.

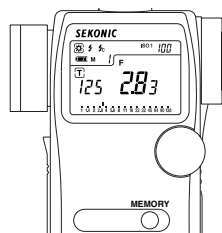

ENGLISH

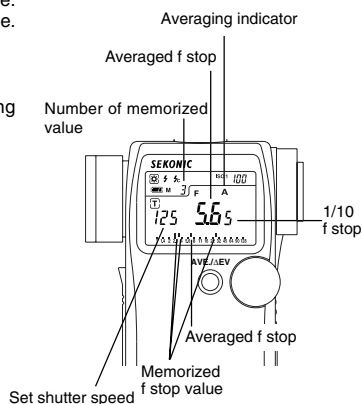

### 3. Brightness difference function

This function is useful for evaluating studio lighting and checking the evenness of the lighting set-up across the subject area.

Take a measured value at a certain point as a standard value. The difference between the standard value and a new measured value is displayed as EV and the f-stop in analog scale.

Example of adjusting lights using brightness measurement with shutter speed priority mode.

1. Turn the Lumisphere UP/DOWN ring ① to lower it to the  mark position.



## 6. Advanced Functions

- Turn any secondary light source off. Point the Lumisphere toward the main light source, from the position of the subject and take a measurement. Press the Memory button (7) and store the value in memory.

- Press the Average/  $\Delta$  EV button (4) and display the "A" mark on the LCD.

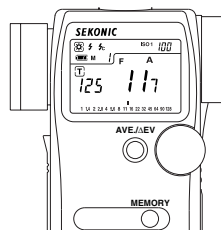

- Turn the main lighting off. Now, point the Lumisphere toward the secondary light source. While the Measuring button (15) is depressed and held down, the indicated difference between the main and auxiliary light sources is displayed in EV values and in bars in analog scale of memory value. A lighting ratio (contrast ratio) can be found in the scale below.

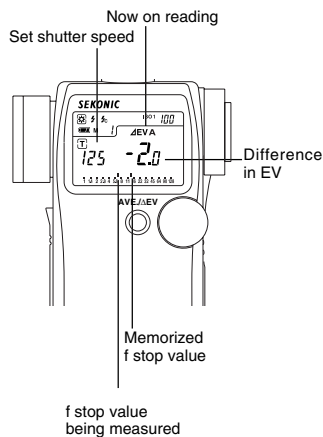

EV difference of $\Delta$ EV value	Contrast ratio
1	2 : 1
1.5	3 : 1
2	4 : 1
3	8 : 1
4	16 : 1



- The Brightness Difference mode can be canceled by pressing the Ave/  $\Delta$  EV button (4).

### Reference:

- To determine exposure after adjusting lights, turn both main and secondary light sources on, raise the Lumisphere to the  $\ominus$  mark position, then take a reading along the camera light axis.

## 6. Advanced Functions

### 4. How to use an incident illuminance (LUX) meter

1. Turn the Lumisphere UP/DOWN ring ① to lower it to the  mark position.
2. Make sure that compensating value (see page 29) is canceled () .
3. Set the meter to EV mode (DIP switch 1) and ISO 100.
4. Place meter parallel to the subject and take a measurement.
5. Convert the measured EV with a conversion table or calculation formula to find the brightness level.



ENGLISH

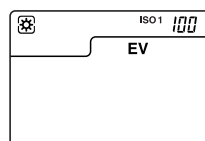

EV value Lux conversion table

Decimal places EV	0	0.5	Decimal places EV	0	0.5
-2	0.63	0.88	9	1300	1800
-1	1.3	1.8	10	2600	3600
0	2.5	3.5	11	5100	7200
1	5.0	7.1	12	10000	14000
2	10	14	13	20000	29000
3	20	28	14	41000	58000
4	40	57	15	82000	120000
5	80	110	16	160000	230000
6	160	230	17	330000	460000
7	320	450	18	660000	930000
8	640	910	19	1300000	1900000

EV value Foot candle conversion table

Decimal places EV	0	0.5	Decimal places EV	0	0.5
-2	0.06	0.08	9	120	170
-1	0.12	0.16	10	240	340
0	0.23	0.33	11	480	670
1	0.46	0.66	12	950	1300
2	0.93	1.3	13	1900	2700
3	1.9	2.6	14	3800	5400
4	3.7	5.3	15	7600	11000
5	7.4	11	16	15000	22000
6	15	21	17	30000	43000
7	30	42	18	61000	86000
8	59	84	19	120000	170000

Reference:

- When the custom setting function is used, it is possible to read the lux or FC display directly (refer to P33).

## 6. Advanced Functions

### 5. How to use a reflected luminance (cd/m<sup>2</sup>) meter

1. Make sure that the compensating value (see page 29) is canceled (**72**).
2. Set the meter to EV mode (DIP switch 1) and ISO 100.
3. Set meter for spot reading.  
Choose angle setting that is best suited for your subject.  
Take the measurement by looking through the finder and aligning so the subject that will be measured is inside the circle.
4. Convert the measured EV with a conversion table or calculation formula to find the luminance (cd/m<sup>2</sup>).

EV value cd/m<sup>2</sup> conversion table

EV	Decimal places		EV	Decimal places	
	0	0.5		0	0.5
3	1	1.4	12	510	720
4	2	2.8	13	1000	1400
5	4	6	14	2000	2900
6	8	11	15	4100	5800
7	16	23	16	8200	12000
8	32	45	17	16000	23000
9	64	91	18	33000	46000
10	130	180	19	66000	93000
11	260	360			

EV value cd/ft<sup>2</sup> conversion table

EV	Decimal places		EV	Decimal places	
	0	0.5		0	0.5
3	0.09	0.13	12	48	67
4	0.19	0.26	13	95	140
5	0.37	0.53	14	190	270
6	0.74	1.1	15	380	540
7	1.5	2.1	16	760	1100
8	3.0	4.2	17	1500	2200
9	5.9	8.4	18	3000	4300
10	12	17	19	6100	8600
11	24	34			

Reference:

- With the 608 Cine, it is possible to read cd/m<sup>2</sup> or foot-lambert directly in the display by using the custom setting function (refer to P33).

## 6. Advanced Functions

### 6. How to change the compensating function

Exposure compensation can be made in precise 1/10 step increments in a +/- 9.9 EV range. Exposure compensation may be desired to match specific requirements, calibration to other light meters, or setting exposure calibration in 1/10 steps up or down from standard ISO film speeds. It may also be desired when requiring compensation for filters, bellows extension, etc. When corrections have been made,  $\pm$  is displayed on the LCD.

ENGLISH

- Making a plus correction (making the film speed / f stop index value higher) will result in underexposing when taking a photograph. Hold the ISO1 button ① and the ISO 2 button ⑥ and turn the Set/change dial ⑤ counter clockwise. The  $\pm$  will appear on the upper right part of the LCD. The index correction will change in +0.1 EV steps up to +9.9.

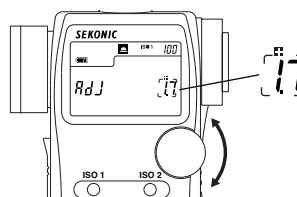

- Making a minus correction will result in overexposing when taking a photograph. Hold the ISO1 button and the ISO 2 button and turn the Set/change dial clockwise. The  $\pm$  will appear on the upper right part of the LCD. The index correction will change in -0.1 EV steps up to -9.9.

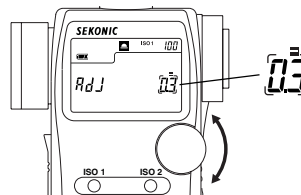

#### NOTE:

- Make corrections after a sufficient number of test in actual photographic conditions, to suit your needs.
- Corrections made effect every mode of the meter.  
If recalibration has been made for specific purpose do not forget to return to original zero settings.

#### Reference:

- When corrected, a plus (+) or minus (-) sign as well as the amount of correction are displayed continuously in the LCD display.
- If the custom setting function is used because of difficulties in setting the correction, the correction amount is not displayed (refer to P33).



## 6. Advanced Functions

---

### 7. Use of the correction indicator function

1. Set the measurement mode (incident light, reflected light) for the desired correction. It is possible to set the amount of correction independently for both incident and reflected light. It is not possible to switch between measurement modes (incident light, reflected light) if the setting is not completed.
2. Select setting number 2 and item 0 in the custom setting mode with DIP switch set to on. If you experience difficulties in displaying the calibration value, set the item number to 1 and select calibration non-display.
3. With the power turned off, CAL (calibration) will be displayed in the shutter speed display and 0.0 in the aperture display when the power button is pressed while pressing ISO1 button ⑪ and ISO2 button ⑥. The value of corrections set in advance will also be displayed.
4. The setting can be changed by pressing the power button ⑫ and turning the Set/change dial ⑤ while pressing ISO1 button and ISO2 button.  
As in the case of the correction value, a single plus (+) or minus (-) sign will be displayed if the calibration value is any value other than 0.

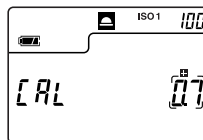

#### NOTE:

- When making corrections, be sure that they satisfy your needs based on the results of adequate test filming.
- While incident and reflected light can be set independently, be aware that fixed light and flash light are corrected uniformly regardless of the measurement.

#### Reference:

- When corrected, a plus (+) or minus (-) sign is displayed continuously in the LCD display.

## 6. Advanced Functions

### 8. Filter setting

#### Filter settings (1)

It is possible to set the correction of the film being used within a range of  $\pm 5$  EV in 1/10 steps. The measurement corresponding to the set correction is displayed while pressing ISO2 button (6).

1. Select setting number 1 and item number 1 in the custom setting mode (refer to P34).
2. Set the desired correction by turning the Set/change dial (5) while pressing ISO2 button (6).

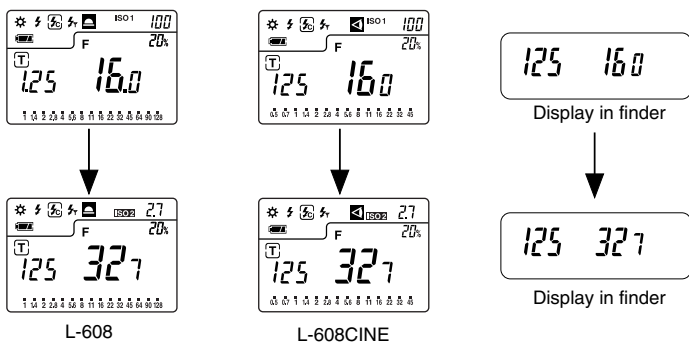

Filter settings (2) (608 Cine compatible)

1. When using in movie filming, it is possible to set 7 different frequently used types of filters.
2. Select setting number 1 and item number 2 in the custom setting mode.
3. The symbol of the desired filter from among the 7 types can be selected by turning the Set/change dial (5) while pressing ISO2 button (6).
4. After filter correction, the filter symbol and corrected F value or EV value are displayed while pressing ISO2 setting button.

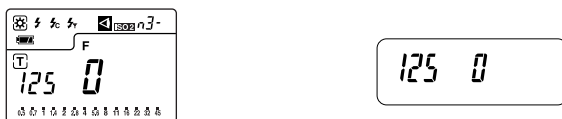

Filters, LCD Display and Corrected Value

Filter No.	85	NDO.3	NDO.6	NDO.9	85N3	85N6	85N9
LCD display	85-	n3-	n6-	n9-	A3-	A6-	A9-
Corrected value (EV)	-0.7	-1	-2	-3	-1.7	-2.7	-3.7

(Filter numbers are Kodak Wratten filter numbers.)

ENGLISH

## 6. Advanced Functions

### 9. Analyzing measurement function

When measuring flash light, the shutter speed and F stop value (value combining ambient light and flash light: total amount of light) are displayed in the liquid crystal display and the ambient light and flash light are each displayed as separate values together with the total amount of light in the dot scale. In addition, the ratio of flash light to the total amount of light is displayed at that time as a value in 10% steps. It is possible to use this value for adjustments, for example, when photographing with a flash in a room illuminated by tungsten lamp light, to emphasize or weaken the tungsten lamp (ambient) light element (enhancing the flash light of the photograph) to match the photographer's intentions.

< Example >

If, under certain conditions, the flash light component is 60% and the tungsten light component is 40%, the display will be as indicated at the right.

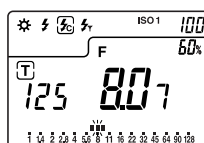

1. To emphasize the tungsten (ambient) light (to imbue the atmosphere with orange-colored tones)  
To increase the ratio of tungsten light, use the Set/change dial (S) to change the shutter speed to slow. It is apparent that the flash light component is now 20%. The dot scale also shows the tungsten light component to be about 2.5 step level higher than the flash light component.

As a result, images on the film are expressed with orange tones that give life to the effect of the tungsten light.

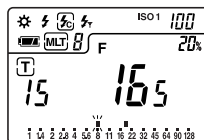

2. To reduce the effect of tungsten light (to realize a more natural atmosphere)

To decrease the ratio of tungsten light, use the Set/change dial to change the shutter speed to fast. It is apparent that the flash light component is now 80%. The dot display also shows the flash light component to be about 1.5 step level higher than the ambient light component.

As a result, the images on the film are expressed in natural color tones.

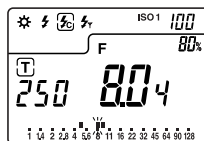

The settings above are made by adjusting the tungsten (ambient) light by the shutter speed. It is also possible to modify the ratio by adjusting the flash light (when changing the distance between the flash and the subject or when changing the amount of light of the flash). When using this method, re-measure each time the flash light is adjusted.

## 6. Advanced Functions

### 10. Custom setting function

It is possible to set the required functions in advance.

ENGLISH

CUSTOM SETTING LIST							
No.	Model	Lighting	Custom Setting name	Item			
				0	1	2	3
1	608	Ambient & Flash	ISO 2 setting	Film Sensitivity 1/3 step	Filter Setting (1) 0.1EV step (±5EV)	—	—
	CINE			Film Sensitivity 1/3 step	Filter Setting (1) 0.1EV step (±5EV)	Filter Setting (2) 7 Filter Name	—
2	608&CINE	Ambient & Flash	Exposure Compensation Display setting	Always display	Not display	—	—
3	608&CINE	Ambient & Flash	Increments of Shutter Speed	1 step	1/3 step	1/2 step	—
4	608&CINE	Ambient & Flash	Increments of Aperture	1 step	1/3 step	1/2 step	—
5	608&CINE	Ambient	T priority mode	Available	Not Available	—	—
6	608&CINE	Ambient	F priority mode	Available	Not Available	—	—
7	608&CINE	Flash	Code-in mode	Available	Not Available	—	—
8	608&CINE	Flash	Code-less mode	Available	Not Available	—	—
9	608&CINE	Flash	Analyzing Measurement	Available	Not Available	—	—
*10	608&CINE	Ambient	Illuminance display	Compound + Individual	Compound	Individual	—
11	608&CINE	Ambient	Illuminance measurement in Incident mode	Not Available	LUX	FC	LUX, FC
12	CINE	Ambient	Illuminance measurement in Reflected mode	Not Available	cd/m <sup>2</sup>	FL	cd/m <sup>2</sup> , FL

\*. Individual: LUX, FC, cd/m<sup>2</sup>, FL

Compound: LUX+T+F, FC+T+F, and cd/m<sup>2</sup>+T+F, FL+T+F (combination)

## 6. Advanced Functions

1. To enter the custom setting mode, set power button ⑫ to the on position setting DIP switch 4 to on. It is not possible to enter the custom setting mode if DIP switch 4 is set to on after turning on the power.

2. When in the custom setting mode, 'CS' (custom setting) is displayed in the ISO display, a setting number between 01-12 is displayed in the shutter speed display and item number 0, 1, 2 or 3 is displayed in the aperture display.

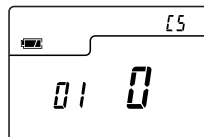

3. Turn the Set/change dial ⑤ and select the custom setting name by the desired setting number.

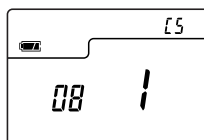

4. The item number will change each time the Mode set button ⑩ is pressed.

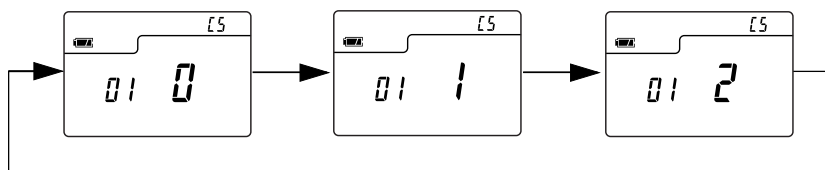

5. Pressing the memory clear button ⑮ in the custom setting will change the setting to item number 0.

6. After completing the custom setting, terminate the custom setting mode by setting DIP switch 4 to off. This operation will also automatically turn off the power. Since the power cannot be turned off by pressing the power button while in the custom setting mode, turn off the power by setting DIP switch 4 to off.

## 6. Advanced Functions

### 11. Radio flash system

Setting the radio wave transmitter module (RT-32; optional) in the main unit and connecting the receiver RR-32 or RR-4; optional) to the flash provides a convenient system that enables one person working alone to measure flash light without a synchro cord, thereby making it possible to take measurements by triggering the flash from the exposure meter.

The unit has 32 channels when the radio wave transmitter module (RT-32) is mounted. Channels 1-16 are single channels and channels 17-32 are quad channels, each of which can be set to 4 sub-channels (a, b, c and d), thus making it possible to control a maximum of 4 flash units. Meanwhile, there are two types of radio signal receiver, RR-32, capable of 32 channel settings, and RR-4, capable of 4 channel settings.

ENGLISH

< Example with optional radio wave receiver module RR-32 >

1. Open battery compartment cover ⑯, remove connector cover and set the radio wave transmitter module (optional) by aligning the connector with the pins.

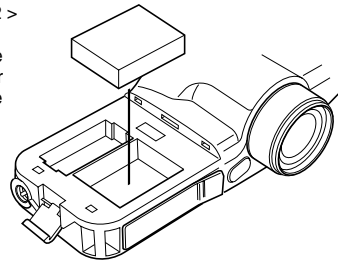

### ⚠ CAUTION

- To prevent damage due to static electricity, release static electricity stored in your body by touching a metal object nearby (door knob, aluminum window frame, etc.) before touching the radio wave transmitter module.

2. Switch to the radio flash mode by using Set/change dial ⑤ while pressing mode set button ⑩.

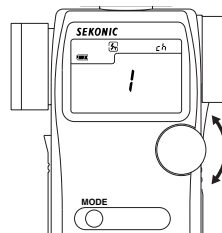

## 6. Advanced Functions

- The set channel number will flicker on and off at this time. Turn the Set/change dial to set the channel setting.
- In the Setting mode, "ch" appears on the ISO indicator. At the same time, channel numbers (1 to 16 and 17 to 32) appear on the F indicator. When the channel number is 17 to 32, sub-channel (A, b, c and d) settings are displayed on the T indicator. In the absence of settings, "-" appears in the figures.

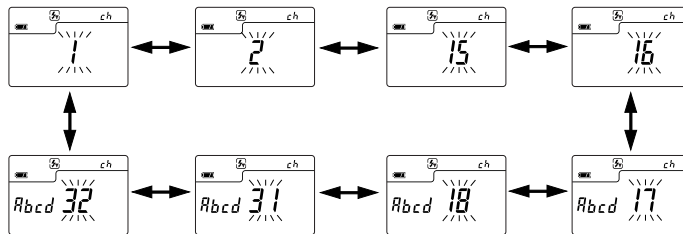

- In sub-channel settings, after the channel is set to 17 to 32, the mode button is pressed. Following this, the 4th figure on the T indicator flickers to indicate that settings may be made. Every time the mode button is pressed, the flicker shifts from sub-channel No. : 4th figure → 3rd figure → 2nd figure → 1st figure → channel No., while permitting settings for each sub-channel. As the Set/change dial is rotated in this state, setting ("A, b, c and d" displayed) and resetting ("-") alternate. During this process, the indicator continues to flicker to indicate the channel being set.

→ Set by manipulating the mode set button.  
 ↔ Set by manipulating the Set/change dial.

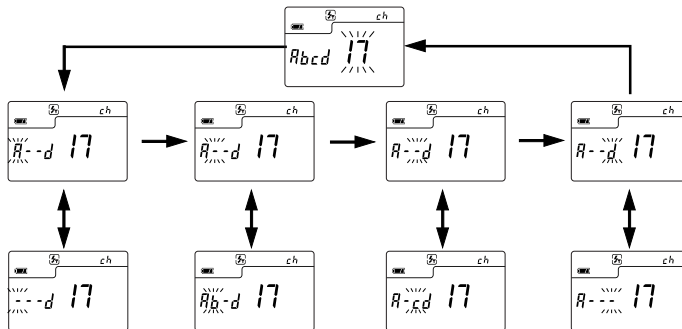

### ⚠ CAUTION

- When using quad channels 17-32, it is not possible to terminate this mode unless a sub-channel has been set (a, b, c or d is displayed).

## 6. Advanced Functions

- 6. Upon setting completion, the Radio flash mode is selected using the Set/change dial while the mode button is depressed.
- 7. Confirm that the unit and the radio wave receiver are set to the same channel number. The flash unit will fire when the measurement button of the unit is pressed and measurements can be made at the same time.

Reference:

- Refer to the receiver instruction manual for the receiver operating method.
- Maximum controllable distance of the radio flash trigger system differs depending on the placement of the device, direction and other factors.
  1. Confirm the direct visible range between the transmitter and receiver.
  2. Place the devices away from large metal objects, concrete, objects with large moisture content (both people and trees fall into the category) and so forth.
  3. Secure the radio wave receiver module in place by using Velcro tape or a tripod hole. Be sure that the entire length of the receiver antenna is higher than the flash pack at this time. Avoid contact between the receiver antenna and metal objects at all times.
  4. Depending on the location, there may be cases when the receiver is incapable of receiving any radio signals whatsoever.

There are various possible reasons for this such as radio signals reflected from nearby objects. This can generally be resolved by shifting the device slightly in one direction or another.

In addition, confirm that the device is not placed behind objects that readily absorb or deflect radio signals such concrete, metal, low hills, etc.

NOTE:

- The radio flash system may be used only in countries where a permit for the control frequency has been issued by the government office in charge.



## 7. Accessories

---

### Mini Light Receptor (Sold separately)

- Incident light receiving unit with a compact 12mm diameter light receiving surface.
- For measuring narrow areas used for photographing small subjects or copy work.

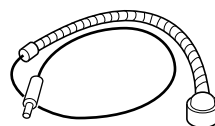

### Booster (Sold separately)

- For light measuring on camera ground glass, focusing screens, SLR eyepieces, microscope eyepiece.
- When the Booster is used without any accessory attachments, it can measure reflected light over approximately a 60 degree angle of field.

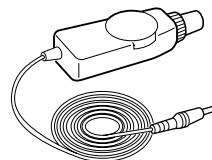

### Synchro cord (Sold separately)

- This is a five-meter long cord with three plugs. An exposure meter, a camera, and a flash can all be connected at the same time. This is convenient when measurements are made, because it is not necessary to plug and unplug the synchro cord.

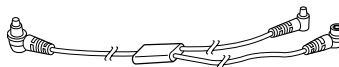

### 18% Gray Card (Sold separately)

- 18% gray card with cover (110mm x 102mm, 4 1/4" x 3 1/2"), folds to 2 3/4" x 4 3/4", and fits in a shirt pocket.

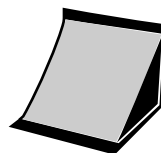

## 7. Accessories

Radio flash system (Sold separately)

- Combining radio wave transmitter module (RT-32) with radio wave receiver (RR-32 or RR-4) enables measurements by triggering the flash from the exposure meter.

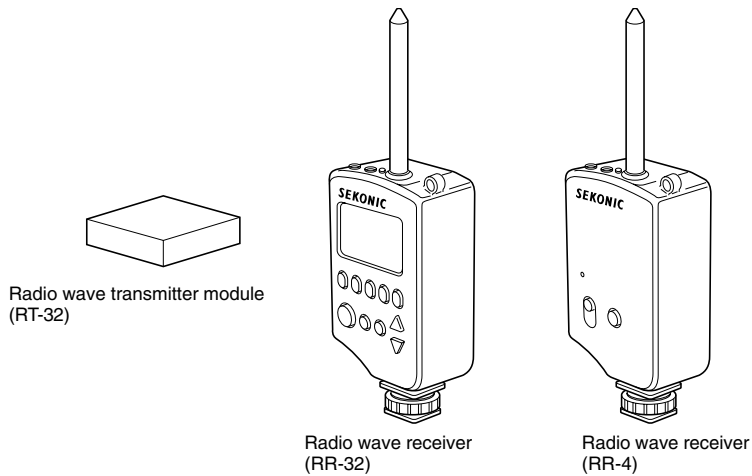

- Light receiving angle 54° (Lumigrid) (Sold separately)**  
This method measures the brightness (luminance) of the light reflected from the subject. It is useful for distant objects such as landscapes, when you cannot go to the position of the subject, or for metering subjects that generate light (neon signs, etc.), highly reflective surfaces or translucent subjects (stained glass, etc.).
- Step-Up Ring (30.5mm → 40.5mm) (Sold separately)**  
The step-up ring, available as an optional accessory, makes it possible to mount step rings and filters of other manufacturers. This simplifies the setting of exposure without the troublesome correction calculation of PL filters, etc.  
The step-up ring can also be used as a hood to protect lenses from scratching, soiling, etc.
- 2x Angle Converter (optional) (Sold separately)**  
Mounting the 2x angle converter to the objective lens unit enables zoom measurements at a light receiving angle of 2°-8°.

ENGLISH

## 8. Technical Data

---

• Type	: Digital exposure meter for ambient and flash meter
• Light receiving method	: Incident light and reflected
Incident light	: Convertible to flat diffuser (Lumisphere in down position)
Reflected light	: 1° to 4° element Zoom (display in finder) Metering distance 1m – ∞
• Light Receptors	: 2-Silicon photo diodes (incident and reflected)
• Metering modes	:
Ambient light	: Aperture priority metering Shutter priority metering EV metering value Simple illumination measurement (lux, foot-candle) Simple brightness measurement (608 Cine only) (foot-lambert, cd/m <sup>2</sup> )
Flash	: With synchro cord (cumulative, non-cumulative) Without synchro cord (cumulative, non-cumulative) Measurement using the optional radio flash system (cumulative, non-cumulative)
• Measuring Range (ISO 100)	:
Ambient light	: Incident light EV-2 to EV 22.9 Reflected light EV 3 to EV 24.4
Flash	: Incident light f0.5 to f128.9 (approx. f175) Reflected light f5.6 to f128.9 (approx. f175)
Illumination:	: 0.63 - 190,000 lux (2 significant digits) 0.12 - 180,000 foot-candle (2 significant digits)
Brightness (608 Cine only)	: 1 - 190,000 cd/m <sup>2</sup> (2 significant digits) 0.3 - 190,00 foot-lambert (2 significant digits)
• Repeat Accuracy	: +/- 0.1 EV or less
• Calibration Constant	:
Incident light metering	: Lumisphere C = 340 Flat diffuser C = 250
Reflected light metering	: K = 12.5
• Display Range	:
Film speed	: ISO 3 to 8000 (in 1/3 steps)
Shutter Speeds	: 30 minutes to 1/8000 seconds (in 1, 1/2 or 1/3 steps) also 1/200, 1/400
Ambient light	: Cine speeds- 2, 3, 4, 6, 8, 12, 16, 18, 24, 25, 30, 32, 36, 40, 48, 50, 60, 64, 72, 96, 120, 128, 150, 200, 240, 256, 300, 360 frames per second (at a 180 degree shutter angle) (608 Cine addition) 1, 75, 90, 100, 125, 250, 375, 500, 625, 750, 1000
Flash	: 30 minutes to 1/1000 second (in 1, 1/2 or 1/3 steps)
Aperture	: f/0.5 to f128 (in 1, 1/2 or 1/3 steps) f/0.5 to f/45 (in 1, 1/2 or 1/3 steps) (608CINE)
EV	: EV -9.9 to EV 40.6 (in 1/10 steps)
Analog display	: F1.0 - F128 (in 1/2 steps), T4.0 seconds - 1/4000 seconds (in 1/2 steps) F0.5 - F45 (in 1/3 steps) (608 Cine)

## 8. Technical Data

ENGLISH

- Shutter opening angle (608 Cine only)  
: 5° ~ 270° (in steps), others: 144°, 172°
- Filter correction (608 Cine only)  
: 85-, n3-, n6-, n9-, A3-, A6-, A9-
- Other features :
- All-weather feature : JIS standard water resistance class 4, splash-proof type
  - Memory function : 9 readings
  - Memory clear · recall function
  - Multiple Flash function : Up to ∞ flash readings
  - Average function
  - Brightness Difference function
  - Analyzing function : 0 to 100% in 10% increments
  - Exposure Out of Range : Eu (underexposure) or Eo (overexposure) indication
  - Correction indicator function : +/- 9.9 EV
  - Battery Power Indicator display
  - Auto Power Off : approx. 20 minutes
- Auto illumination  
DIP switch mode selection  
1/4" Tripod socket : For placing meter in subject area for cordless flash measuring.  
Second ISO film speed setting
- Battery used : one of CR123A battery (lithium dry cell)
- Operating temperature range : -10 ~ 50°C
- Storage temperature range : -20 ~ 60°C
- Dimensions : 90 w × 170 h × 48 d mm
- Weight : 268 g (with battery)
- Standard accessories supplied : Soft case, strap, lens cap, synchro terminal cap, CR123A lithium battery × 1
- Radio wave frequency
- |          |             |                  |
|----------|-------------|------------------|
| FCC & IC | : CH1 ~ 16  | 344.0MHz         |
|          | : CH17 ~ 32 | 346.5 ~ 354.0MHz |
| CE       | : CH1 ~ 16  | 433.62MHz        |
|          | : CH17 ~ 32 | 434.22MHz        |

Features and specifications are subject to change without notice.

## 9. Safety Guide

---

 WARNING:

- Please keep in a location where an infant cannot reach and accidentally get the strap wrapped around his neck. There is danger of strangulation.
- Never place batteries in fire, short, disassemble, or heat them. The batteries might break down, and cause injury or pollute the environment.

 CAUTION:

- Do not look directly at the sun through the viewfinder, because of potential eye injury.
- If you are operating the exposure meter in areas under wet conditions or high humidity, keep the sync post covered. If you are using flash in these conditions, Cordless Flash mode is recommended.

## 10. Care and Maintenance

### NOTE:

- Although this meter has an All-weather design for everyday use (JIS standard water resistance class 4), do not place it in water or use it underwater. This will cause it to malfunction.

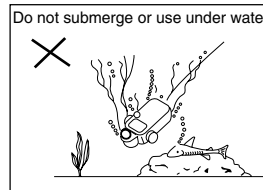
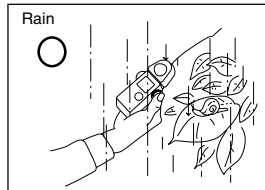
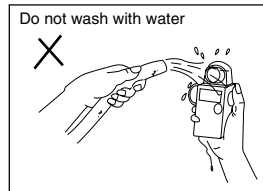
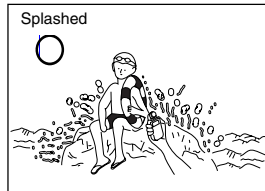

- To avoid damaging this meter, never drop it or subject it to shock.
- Avoid storing it in places with high temperatures or humidity.
- Avoid excessive temperature changes which could cause internal condensation, resulting in malfunction.

ENGLISH

### Maintenance Notes

- If your meter is splashed with water, wipe immediately with a soft dry cloth.
- Avoid applying excessive force on the rubber seal of the battery compartment cover. Do not attempt to remove the rubber seal of the battery compartment cover.
- If the rubber seal's surface is damaged, water or moisture may enter and damage the meter. If this has happened, you must send your meter to the Sekonic Service Center in your country.
- Keep the surface of the Lumisphere and the front and rear surface of the Zoom lens free from dust, dirt, and scratches, which could affect accuracy.
- Never use organic cleaners (like thinner or benzene). Clean with soft dry cloth.



## FCC & IC compliance information:

---



Warning: Changes or modifications to this unit not expressly approved by the party responsible for compliance could void the user's authority to operate the equipment.

Note: This equipment has been tested and found to comply with the limits for a Class B digital device, pursuant

To Part 15 of the FCC Rules. These limits are designed to provide reasonable protection against harmful interference in a residential installation. This equipment generates, uses, and can radiate radio frequency energy and, if not installed and used in accordance with the instruction, may cause harmful interference to radio communication.

However, there is no guarantee that interference will not occur in a particular installation. If this equipment does cause harmful interference to radio or television reception, which can be determine by turning the equipment off and on, the user is encouraged to tray to correct the interference by one or more of the following measures:

- \* Reorient or relocate the receiving antenna.
- \* Increase the separation between the equipment and receiver.
- \* Consult the dealer or an experienced radio/TV technician for help.



This devices complies with Part 15 of the FCC rules and also with RSS-210 of Industry & Science Canada. Operation is subject to the following two condition: (1) This device may not cause harmful interference, and (2) this device may not cause harmful interference, and (2) this device must accept any interference received, including interference that may cause undesired operation.

FCC ID Number: PFK-608-01

Canada:

