

# **EoC MDU Wi-Fi Voice Endpoint**

## **User's Guide**

V1.0

---

# FCC STATEMENT

This device complies with **Part 15** of the FCC Rules.

Operation is subject to the following two conditions:

- (1) This device may not cause harmful interference, and
- (2) This device must accept any interference received, including interference that may cause undesired operation.

**NOTE:** This equipment has been tested and found to comply with the limits for a Class A digital device, pursuant to Part 15 of the FCC Rules. These limits are designed to provide reasonable protection against harmful interference in a residential installation. This equipment generates, uses, and can radiate radio frequency energy and, if not installed and used in accordance with the instructions, may cause harmful interference to radio communications. However, there is no guarantee that interference will not occur in a particular installation. If this equipment does cause harmful interference to radio or television reception, which can be determined by turning the equipment off and on, the user is encouraged to correct the interference by one or more of the following measures:

- Reorient or relocate the receiving antenna.
- Increase the separation between the equipment and receiver.
- Connect the equipment into an outlet on a circuit different from that to which the receiver is connected.
- Consult the dealer or an experienced radio/TV technician for help

**CAUTION:** Any changes or modifications not expressly approved by the party responsible for compliance could void the user's authority to operate the equipment.

## **Introduction**

This EoC (Ethernet over Coax) MDU Wi-Fi Voice endpoint connects the telephone, wireless and Ethernet devices to a high speed access for Internet access. This endpoint brings you the latest Ethernet compatible technology that uses the coaxial cable as the network's physical wiring thereby eliminating the need to install new wiring. It is designed to operate on the coaxial TV cable installed in building.

This endpoint is to connect PCs, telephone and wireless devices to broadband access of cable operators by simply plugging into the existing coaxial F-Type connector in home.

## **Features**

- Plug & Play
- Using existing coaxial TV cable to provide in-building distribution network of broadband access
- Shares Internet access and cable TV video
- 1 port connection Support 700Mbps Ethernet over Coax (EoC)
- 2 Standard 10/100BaseT Fast Ethernet ports for connecting to PC or Set-Top-Box(STB)
- 1 Phone Port for VoIP Voice Service
- IEEE 802.11 b/g/n Wi-Fi MIMO Interface
- Configurable QoS, Tag VLAN, Bandwidth Control
- DHCP Option82 and Snooping Support
- Statistics and Status Information Support

# HARDWARE INSTALLATION

## Parts Names and Functions

### LED Indicators on the Rear Panel

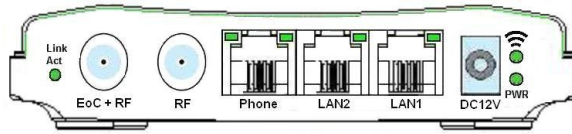

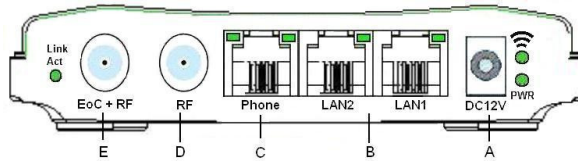

Port	LED	Status		
		ON	Flashing	OFF
DC12V	<b>PWR</b>	Power ON	N/A	Not powered
LAN1	<b>LAN1</b>	Link	Receive or Transmit	Disconnect or Link fail
LAN2	<b>LAN2</b>	Link	Receive or Transmit	Disconnect or Link fail
Phone	<b>Left</b>	Link	N/A	Disconnect or Link fail
	<b>Right</b>	Connected	Call Progress	No Call
Wi-Fi		Link	Receive or Transmit	Disconnect or Link fail
EoC + RF	<b>Link Act</b>	Link	Receive or Transmit	Disconnect or Link fail

## Ports on the Rear Panel



	Port Name	Type	Functions
A	<b>DC12V</b>	DC	Connect to the power adapter plug.
B	<b>LAN1/LAN2</b>	RJ-45	Connect to Ethernet port on PC or Set-Top-Box for Internet Access.
C	<b>Phone</b>	RJ-11	Connect to Telephone Set
D	<b>RF</b>	F	Connect to TV
E	<b>EoC + RF</b>	F	Connect to F-Connector on wall

## Essential Hardware

Items Included	Description	Purpose
	EoC MDU Wi-Fi Voice Endpoint	Main Unit
	Coaxial Cable (F-Type/ RG-59U)	Connects from EoC+RF port to coax F-Type connector on the wall outlet.

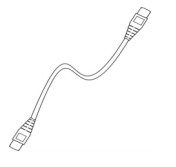
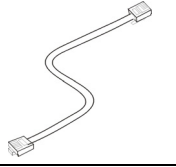
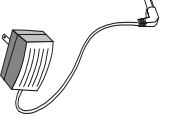
	CAT5 Ethernet cable	Connects from LAN port to Ethernet enabled devices as PC or STB
	Telephone wire	Connects Phone port to phone set
	DC12V Power adapter	Connects from Power port of the main unit into a wall outlet

### Hardware Connections

1. Select a convenient location for the EP near the PC or Ethernet device to which it will be connected. The EP should be kept away from excessive heat.
2. Using one coaxial cable to connect the **EoC+RF** port to F-Type connector on the wall. Using another coaxial cable to connect the other F-type **RF** port to TV set (optional).
3. Connect the **LAN1/LAN2** port to your Ethernet-equipped device.
4. Connect the telephone to **Phone** port.
5. Connect the power adapter to the **DC12V** port into a wall outlet.

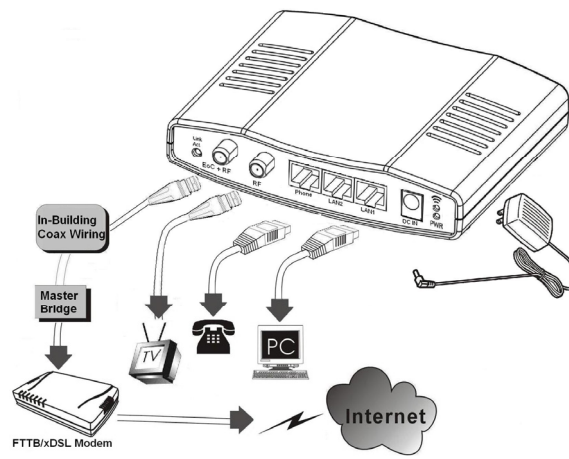

The figure above shows how to connect PON/FTTx/xDSL modem, user's TV and PC to the WiFi endpoint via in-building coaxial cable network.

Now you should have connected the **LAN** port, **EoC** port and the **DC12V** port to the appropriate devices or lines. LED will be as:

PWR	ON
LAN	ON
WiFi (WiFi)	ON
Phone (Left)	ON
EoC+RF Link/Act	ON

For more information on LEDs, see section entitled "[LED Indicators on the Rear Panel](#)"



## **TROUBLESHOOTING**

Please refer to the list below to aid in troubleshooting.

### **The PWR (green) LED is off.**

- *Make sure the power adapter is properly plugged into a live electrical outlet.*

### **The LAN (Ethernet) LED is off.**

- *Make sure the connection to LAN port is secure.*
- *The Ethernet device to which you are connected should be powered on and properly configured.*

### **The EoC+RF Link/Act LED is off**

- *Check the connection to EoC+RF port is secure.*
- *The device to which you are connected should be powered on and properly configured.*
- *Make sure the quality of coaxial connector and cable is good.*

### **The (WiFi) LED is off.**

- *Power off then power on the endpoint device.*

### **Cannot connect to the Wi-Fi AP.**

- *Make sure if the settings are correct by re-configuring the endpoint device via Master.*
- *Note the default SSID is “**WIFI-EP**” and the default WPA/WPA2 pre-shared key is “**endpoint**” before applying (**Reconfig**) new settings.*

### **The Phone (Left) LED is off.**

*Check the VoIP SIP registered account is correct.*

## **SPECIFICATIONS**

### **Standards**

- IEEE 802.3u 100BaseT Fast Ethernet
- Ethernet over Coax (EoC) compliant
- IEEE 802.11b/g/n compliant

### **Data Rates**

- EoC: 320Mbps throughput / 700 Mbps Phy Rate
- Ethernet: 10/100 Mbps
- Wi-Fi : 300Mbps maximal

### **Transmission Range**

- EoC: Up to 70dB attenuation
- Ethernet: 100 meters maximum

### **Power Consumption**

- 12V DC, Less than 8 watt

### **Certifications**

- CE, FCC Part 15

### **LEDs**

- Power
-  (WiFi) Link/Activity
- Ethernet Link/Activity
- EoC Link/Activity
- Phone Link and Call Progress

### **Connectors**

- Two F-Type connectors, one for connecting with Master device, and one for TV Bypass
- Two RJ-45 for 10/100Mbps Ethernet
- One RJ-11 for Telephone