

# Series 24000

---

Bi-static Microwave Intrusion Detection System

# Installation & operation guide

E4DA0202-001, Rev E  
First Edition  
November 19, 2002

**Senstar**  **Stellar**

---

## **Senstar-Stellar Corporation**

119 John Cavanaugh Drive  
Carp, Ontario  
Canada K0A 1L0  
Tel: (613)-839-5572  
Fax: (613)-839-5830

Website: [www.senstarstellar.com](http://www.senstarstellar.com)  
Email address: [info@senstarstellar.com](mailto:info@senstarstellar.com)

See back cover for regional offices.

E4DA0202-001, Rev E  
First edition

Senstar-Stellar and the Senstar-Stellar logo are registered trademarks of Senstar-Stellar Corporation. Copyright © 2002 Senstar-Stellar Corporation. All rights reserved. Printed in Canada.

The information provided in this guide has been prepared by Senstar-Stellar Corporation to the best of its ability. Senstar-Stellar Corporation is not responsible for any damage or accidents that may occur due to information about items of equipment or components not manufactured by Senstar-Stellar Corporation. Features and specifications are subject to change without notice.

FCC Certification: FL924000

This device complies with FCC Rules Part 15. Operation is subject to the following two conditions:

1. This device may not cause harmful interference, and
2. This device must accept any interference that may be received, including interference that may cause undesired operation.

Any changes or modifications not expressly approved by Senstar-Stellar Corporation could void the user's authority to operate the equipment.

---

# Table of contents

---

<b>1</b>	<b>Overview</b>	<b>1-1</b>
	Introduction	1-1
	General description	1-1
<b>2</b>	<b>Site planning &amp; design</b>	<b>2-1</b>
	Site preparation	2-1
	Site selection	2-1
	Site design	2-3
	Zone placement	2-3
	Zone length	2-3
	Offsets	2-3
<b>3</b>	<b>Installation</b>	<b>3-1</b>
	Unpacking and inspection	3-1
	Optional components	3-1
	Transit damage	3-2
	Tools and equipment	3-2
	Installation - mechanical	3-3
	Mounting units	3-3
	Align head-to-head	3-5
	Optional wall mounting	3-5
	Determining mounting height	3-6
	Chart axis	3-6
	Node curves	3-6
	Installation - electrical	3-7
	Transmitter wiring	3-8
	Receiver wiring	3-10

**4 Operating instructions - - - - - 4-1**

Preliminary check - - - - - 4-1  
Channel select switch - - - - - 4-1  
Range switch - - - - - 4-1  
Latch/Timed jumper - - - - - 4-1  
Sensitivity jumper - - - - - 4-2  
Antenna pattern - - - - - 4-2  
Electrical alignment - - - - - 4-3  
Sensitivity adjustment - - - - - 4-5

**5 Troubleshooting**

Return for repair procedures- - - - - 5-1  
Nuisance alarm - - - - - 5-1  
Continuous alarm - - - - - 5-1  
No alarm - - - - - 5-1  
Test points - - - - - 5-2

**Appendix a - - - - - Specifications**

**Appendix b - - - - - Application notes**

# 1

# Overview

---

## Introduction

The Series 24000 Microwave Intrusion Detection System is designed for exterior perimeter intrusion detection applications. The Series 24000 detects movement within a microwave field between the Transmitter and Receiver and initiates an Alarm to alert responding personnel.

## General description

The Senstar-Stellar Microwave Intrusion Detection System consists of a microwave transmitter unit and receiver unit. Each system is designed to detect motion in a specified area called a detection zone (see Figure 1-1). This detection zone is established by the transmitter unit sending continuous microwave signals to the receiver unit. Any motion in this detection zone causes a variation in the received signal strength. These signal variations are detected by the receiver unit and processed to give an intrusion notification.

The transmitter/receiver unit is mounted in a weatherproof enclosure. Each enclosure contains the respective electronic circuitry, and may be wired to report attempts of tampering. An antenna is part of each electronic enclosure. The antenna on the transmitter unit contains the microwave source. The receiver antenna contains the microwave detector.

This Installation and operation guide is intended for the person(s) who will be doing the initial site layout and installation of the Series 24000 Microwave Intrusion Detection System. It provides the information required to install the system, from the time of unpacking shipped equipment to verification of an operational system after installation. Site preparation, installation procedures, and general theory of operation are covered by this guide.

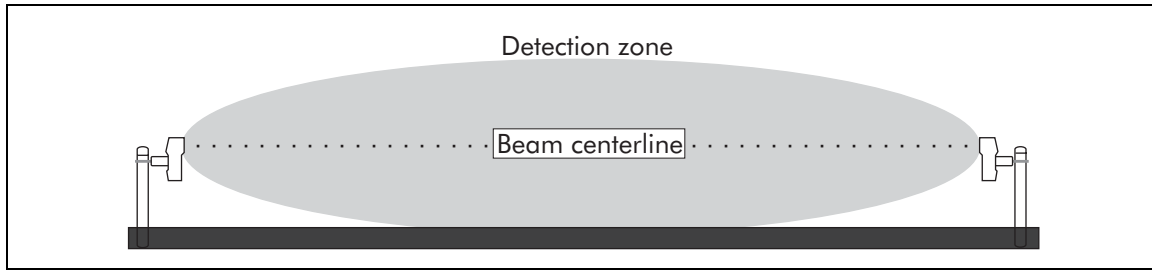

Figure 1-1: Series 24000 intrusion detection system

# 2 *Site planning & design*

---

*NOTE: Refer to Appendix b, Application notes for additional information on microwave site planning and design.*

## **Site preparation**

The amount and type of site preparation required depends on the level of security desired. The physical specifications for a high security detection zone are:

- Transmitter/receiver separation distance no longer than 100 m (328 ft.)
- Terrain must be level to grade,  $\pm 7.6$  cm (3 in.)
- Terrain finished with crushed rock (2.5 cm {1 in.} max.) to a depth of 10 cm (4 in.) or paved zone completely void of vegetation
- Transmitter/receiver units mounted 61 cm (24 in.) beam centerline (center of antenna) to ground

When physical properties of the detection zone are not within these parameters, the system capabilities are diminished. High security applications require much more stringent specifications than do applications where only a beam-break alarm is required. The following definitions should be used to determine the level of security required:

High Security Zone - detection of intruder stomach-crawling parallel to the beam.

Medium Security Zone - detection of intruder crawling on hands and knees.

Low Security Zone - detection of a walking intruder, vehicles, etc. (Beam-break alarm only).

## **Site selection**

A physical survey of the intended site is essential. During this survey, all physical features of the site should be noted. Make accurate distance measurements of the area to be protected and draw a rough sketch. Pictures taken during this survey are also a valuable aid. Most sites may be used if the following parameters are kept in mind:

### **Line of sight**

A clear, direct line-of-sight between the receiver and transmitter units must be maintained at all times. The sensor system will work best with a long, flat, detection zone.

## **Movement**

Movement of objects (trees, brush, shrubs, etc.) in the detection zone may cause the system to alarm. The detection zone should not include water, such as lakes, streams or ponds which, if moving, may result in alarms. Depending on the level of security desired, the presence of wildlife (rabbits, cats, dogs, deer, cows, etc.) may result in nuisance alarms. The motion of semi-rigid objects (metal buildings, fences, materials, etc.) that are outside the intended protection zone may produce nuisance alarms if the objects are illuminated by the transmitted microwave signal.

## **Depressions**

Drainage ditches and gullies should either be avoided or filled in. These depressions could allow undetected access by an intruder, and periodic water flow will cause nuisance alarms.

## **Vegetation**

Trees, bushes, shrubs, and tall grass within the detection zone will have an adverse effect on the nuisance alarm rate and on detection probability, especially when this vegetation is wet with rain or dew.

## **Ground cover**

The type of ground cover in the detection zone has several effects on the sensor system:

### **Crushed rock**

This is the optimum type of ground cover for high security applications. Crushed rock will disperse rain drops, whereas a hard, smooth surface will cause raindrops to bounce, creating movement in the detection zone. Microwave energy is also reflected off the rocks, increasing the sensitivity of the detection zone. This high detection zone sensitivity allows the system to have a lower alarm sensitivity. Crushed rock will allow rainwater to seep into the rocks, preventing it from forming puddles that may cause nuisance alarms.

### **Paved surface**

If the detection zone requires snow removal, then a paved surface is recommended. Accumulated snow will change the detection characteristics.

### **Other surfaces**

Closely mowed grass (7.6 cm {3 in.} or less) asphalt, concrete and hard-packed clay are satisfactory surfaces for medium and low security applications.

## **Terrain**

Sharp deviations in terrain within the line-of-sight may result in “holes” in the detection zone. In addition, this may produce a detection “shadow.” This shadow creates an unmonitored area for entry of an intruder.



# Site design

Detailed site design drawings for the microwave sensor system should be prepared as soon as possible after the site survey. Dimensions and elevations should be shown on these drawings, as well as the location of the physical objects noted during the survey. After the site drawings have been completed, the next step is to plot each microwave zone. Zone placement, zone length, and offsets are essential to the design of a reliable microwave security system.

## Zone placement

The transmitter and receiver units must be mounted with a direct, unobstructed line-of-sight between them. The suggested minimum distance between the beam centerline and any object that may move (fences, trees, bushes, shrubs, etc.) is detailed in Table 2-1. Separation distances are based on average conditions and may vary depending on site conditions, mounting height, type of obstacle, etc.

Zone length	Distance from object (minimum)
91 m (300 ft.)	1.6 m (5.25 ft.)
122 m (400 ft.)	2.1 m (7 ft.)
150 m (492 ft.)	2.7 m (8.75 ft.)

Table 2-1: zone length/object

## Zone length

The optimum length of each zone depends on several factors:

- level of security required
- physical constraints (terrain, trees, buildings, etc.)
- space available for the detection zone

The maximum zone length for a low security application is 150 m (492 ft.).

The maximum zone length for a high security application is 100 m (328 ft.).

## Offsets

The area immediately below the transmitter/receiver antenna is not exposed to the sensor system's microwave energy. To compensate for this unmonitored area, an offset of the sensor system is required (see Figure 2-1). Offsets prevent the possibility of intruders crawling under or jumping over a transmitter or receiver unit to gain access to the protected area. The offset distances are based on the transmitter/receiver mounted at a height of 61 cm (24 in.) (beam centerline to ground). As the mounting height of a transmitter and receiver is increased a longer offset is necessary. Different types of offsets are shown in Figure 2-2.

*NOTE: Medium and low security applications usually require higher mounting heights and shorter offsets than those required for high security applications.*

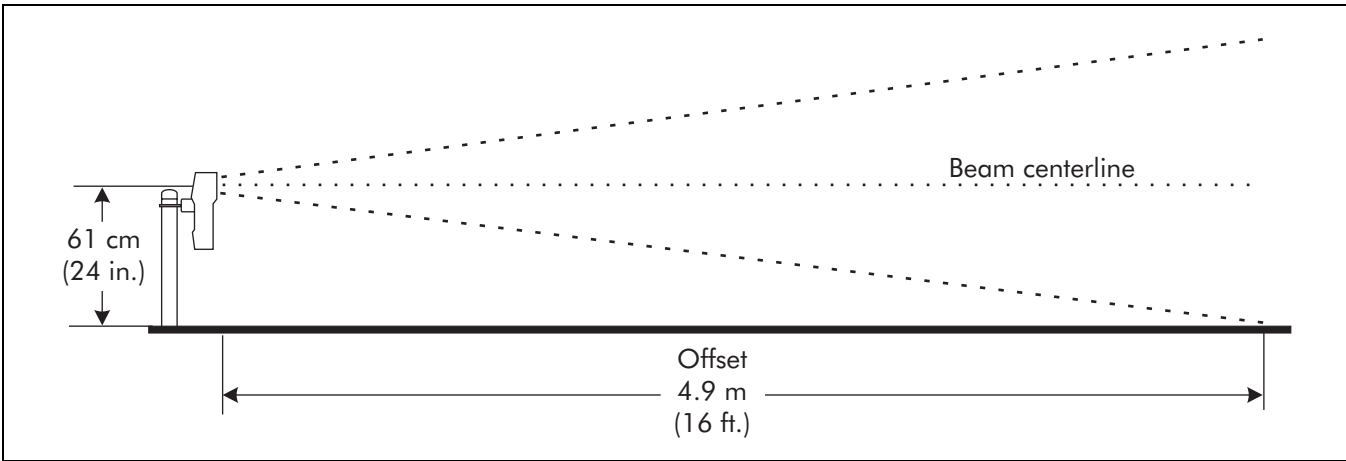

Figure 2-1: Offset area

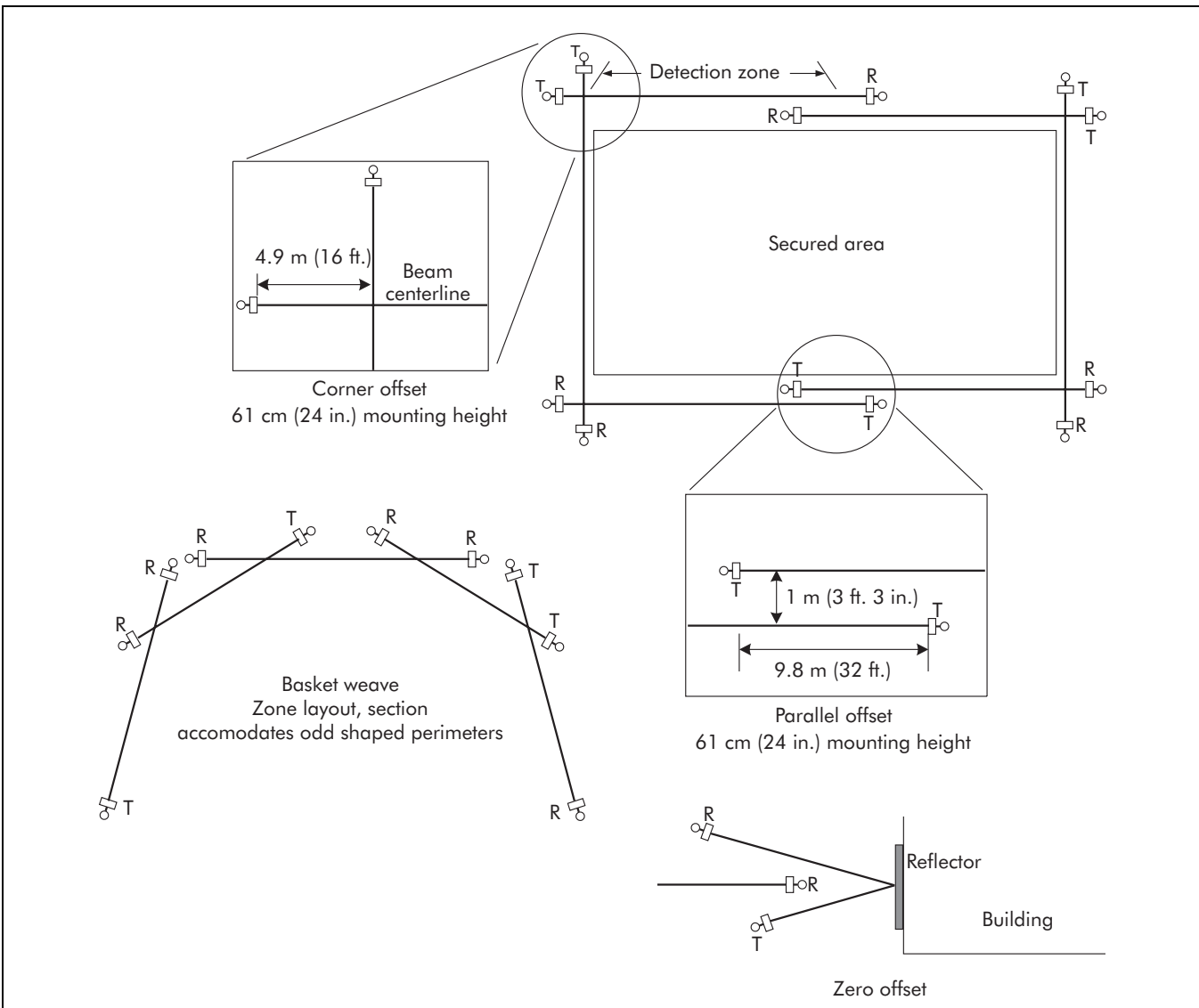

Figure 2-2: Offset arrangements - typical high-security applications

# 3

# *Installation*

---

## **Unpacking and inspection**

The Series 24000 Intrusion Detection System is shipped in one carton. Immediately after unpacking, identify all components and report any shortages to Senstar-Stellar. The components in each carton are as follows:

### **Transmitter unit**

Antenna enclosure assembly. Transmits microwave beam.

### **Receiver unit**

Antenna enclosure assembly (see Figure 3-1). Receives microwave beam.

### **Mounting hardware**

One set per unit. Facilitates mounting transmitter/receiver units to 9 cm (3 1/2 in.) OD post.

### **Installation and operation guide**

Packed in carton.

## **Optional components**

### **Power distribution box**

Provides convenient wiring interface between units and alarm reporting panel. Includes tamper switch and 115 VAC outlet receptacles.

### **Power supply with standby battery**

Plugs in to 115 VAC outlet, provides 2 A continuous power with 5 AH standby battery.

## Wall mounting brackets

Facilitates mounting the unit directly to a wall.

## Transit damage

Although the transmitter and receiver are carefully packed, check for possible transit damage. If any damage has occurred in shipping, leave the packing carton and components intact and notify your carrier. Senstar-Stellar is not responsible for shipping damage.

## Tools and equipment

Nomenclature	Manufacturer/model	Purpose
digital multimeter	Fluke 8062B	Measure Automatic Gain Control voltage during initial alignment
wrench, adjustable	common	Mount unit to post and adjust pitch of units
Screwdriver, slot 15 cm long x 6 mm wide (6 in. long x 1/4 in. wide)	common	Connect external leads to unit terminal board
Screwdriver, slot 10 cm long x 3 mm wide (4 in. long x 1/8 in. wide)	common	Adjust sensitivity and alarm duration
Sphere, polished aluminum 30.5 cm (1 ft.) with sled	Universal Metal Spinning Albuquerque, NM 87110	Adjust sensitivity in high-security applications

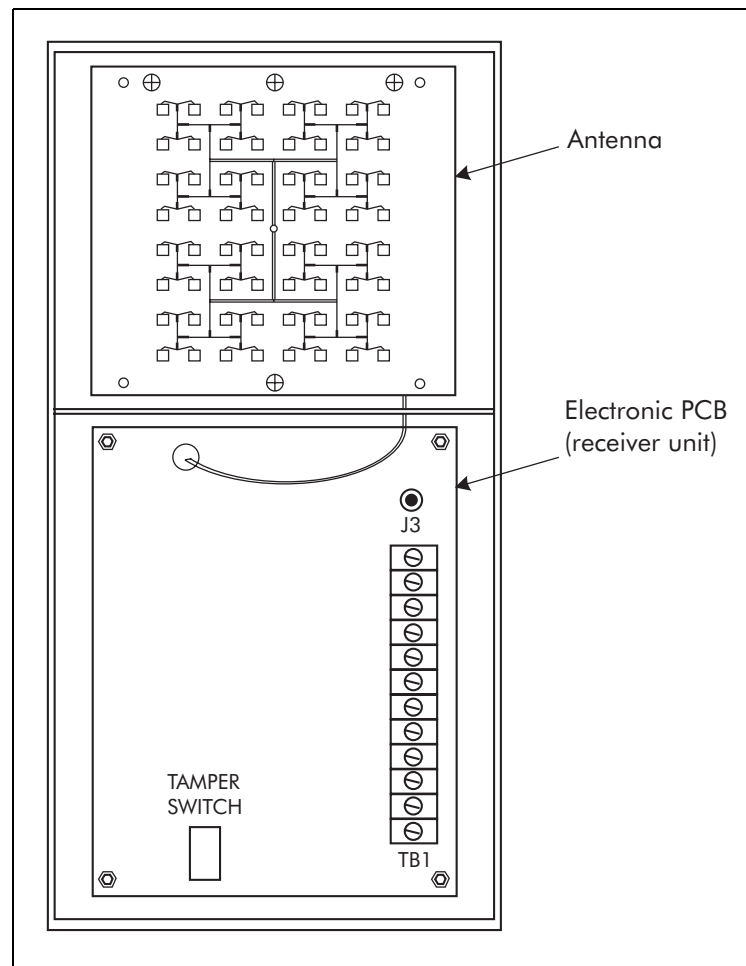

Figure 3-1: Series 24000 microwave unit (receiver)

## Installation - mechanical

### Mounting units

Both the transmitter and receiver units must be securely mounted to prevent movement or vibration. Excessive movement or vibration of either units will cause nuisance alarms. Windy conditions are a potential problem if the units are not mounted properly. Refer to Figure 3-2 for a visual overview of the following instructions.

### Set post

The transmitter and receiver units have been designed to mount on a 9 cm (3 1/2 in.) OD post. A 2.44 m (8 ft.) post is typically used with 91 cm (3 ft.) of the post buried in a concrete footing.

*NOTE: Mounting posts are not included.*

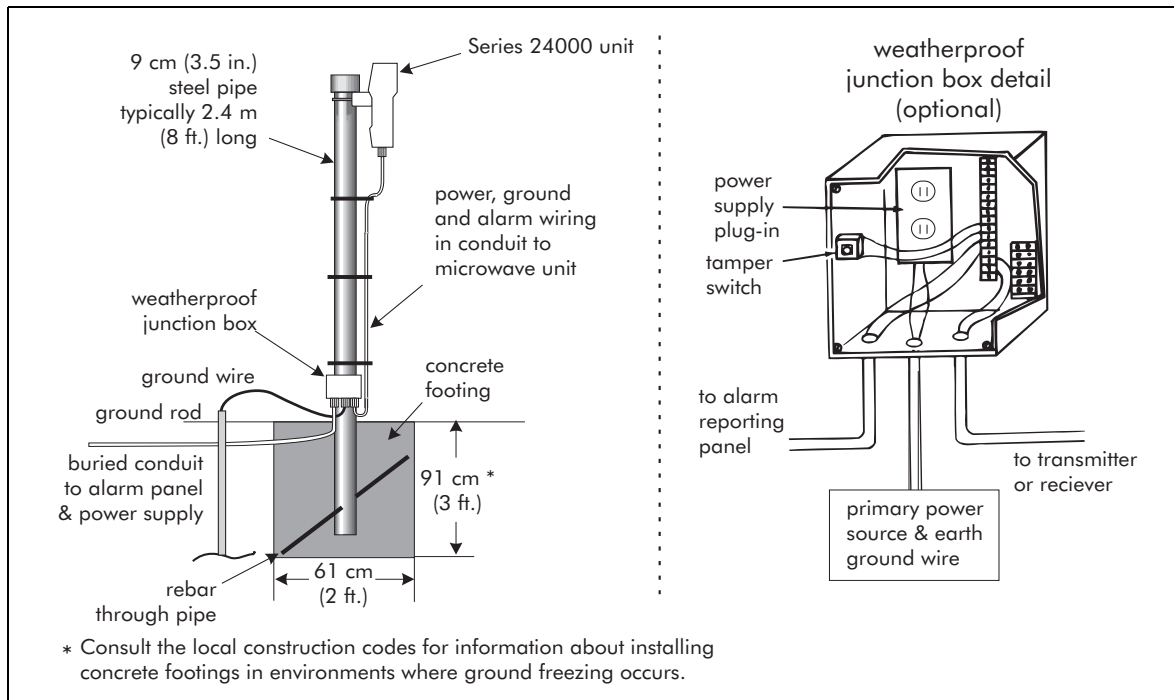

Figure 3-2: Post installation and unit mounting

## Foundation

The foundation for the mounting posts in normal soil should be at least 91 cm (3 ft.) deep and 61 cm (2 ft.) in diameter. If soil conditions are such that a non-shifting foundation is questionable, then a larger footing should be considered. In areas where extremely low temperatures may cause frost heaving, use a truncated pyramid base foundation.

## Rebar

When the foundation concrete cures, there is a possibility of it pulling away from the post, allowing for rotation of the mounting post. Placement of rebar below ground level in the foundation and through the post is suggested to prevent this.

## Power supply hook-up

A weatherproof junction box in the vicinity of each unit's mounting post is the best location for terminating the primary power supply. A double-row terminal block allows this to become a convenient junction box for those lines running back to an alarm reporting panel. Conduit for the power supply junction box should be installed in the foundation as illustrated in Figure 3-2. Be sure to mount the junction box so that it will not interfere with the antenna enclosure, and is not in the microwave beam.

## Transmitter/Receiver

Mount the transmitter and receiver units on their respective posts, using the pipe clamps and hardware provided. The mounting height of the transmitter and receiver units is measured from the center of the antenna to ground. Refer to Determining mounting height on page 3-6 for the approximate mounting height of the microwave units.

---

## Transmitter/Receiver grounding

Connect a ground wire(s) to a properly installed ground rod. Connect the ground wire(s) to the appropriate terminal(s) on the Transmitter/Receiver PCB. (Refer to Figures 3-4 and 3-5 for wiring diagrams of the Transmitter and Receiver circuitry.)

*NOTE: Senstar-Stellar recommends using a low resistance (5  $\Omega$  or less) earth ground connection at each unit. Consult the local electrical codes for additional grounding information.*

## Conduit

1.3 cm (1/2 in.) flexible conduit should be used to run connections to and from the transmitter/receiver units and power supply junction box. Allow enough slack in this flexible conduit to provide a “drip loop” and vertical movement of  $\pm$  46 cm (18 in.).

*NOTE: Conduit and conduit fittings are not included.*

## Align head-to-head

Physically point the transmitter and receiver toward each other and slightly tighten the clamp nuts so the units will not fall. Loosen the two nuts on either end of the bracket, and aim the units (in the pitch axis) toward each other. Slightly tighten the two nuts.

*NOTE: This is a preliminary mechanical alignment only. A more precise electrical alignment will be accomplished as part of the Operating instructions procedure.*

## Optional wall mounting

*NOTE: When using the optional wall mount bracket, disregard references to post mounting, and follow these instructions.*

1. Power the units up by following the Installation - electrical instructions. This power may be temporary (batteries).
2. Using the mounting height chart, Figure 3-3, determine the approximate mounting height of the units.
3. Follow the Operating instructions to ensure the units are functioning correctly. Connect a digital voltmeter to TP-10 (AGC Voltage) on the receiver. Move the “LATCH - TIMED” jumper to the “LATCH” position to speed up the AGC response.
4. Slowly move both units vertically up and down from the nominal mounting height determined from Figure 3-3. The optimum mounting height is reached when the digital voltmeter reading is the highest. Mark the spot on the wall and attach the wall mount to the wall.
5. Attach the units to the mounts.

# Determining mounting height

The mounting height chart (Figure 3-3) is used to determine the best theoretical mounting height of the transmitter/receiver units for optimum efficiency of the sensor system. This height chart is intended to furnish a preliminary mounting height only. The final operating height will be determined during electrical alignment and final adjustment.

## Chart axis

The horizontal axis of the height chart represents the distance between the transmitter and receiver units. The vertical axis represents the mounting height of the transmitter/receiver units from the center of the antenna to the ground.

## Node curves

The node curves (N1, N2, N3, N4, N5 and N6) represent the pivot point for coordinating distance (horizontal axis) to mounting height (vertical axis). Those mounting height and distance coordinate lines that meet in the area between the node curves should be avoided. Coordinate lines that meet on the node curves are preferred because they will result in higher signal strength at the receiver and a wider fade margin. However, choosing a mounting height at N1 or below will also allow satisfactory system operation.

### Example:

The distance between the transmitter and receiver is 84 m (275 ft.). Locate this distance on the height chart's horizontal axis. Plot a vertical line from this distance point across the node curves. These height measurements represent the best theoretical mounting heights for this example. They are 51 cm (20 in.) or less for the N1 curve and below, 91 cm (36 in.) for the N2 curve, 114 cm (45 in.) for the N3 curve, etc.



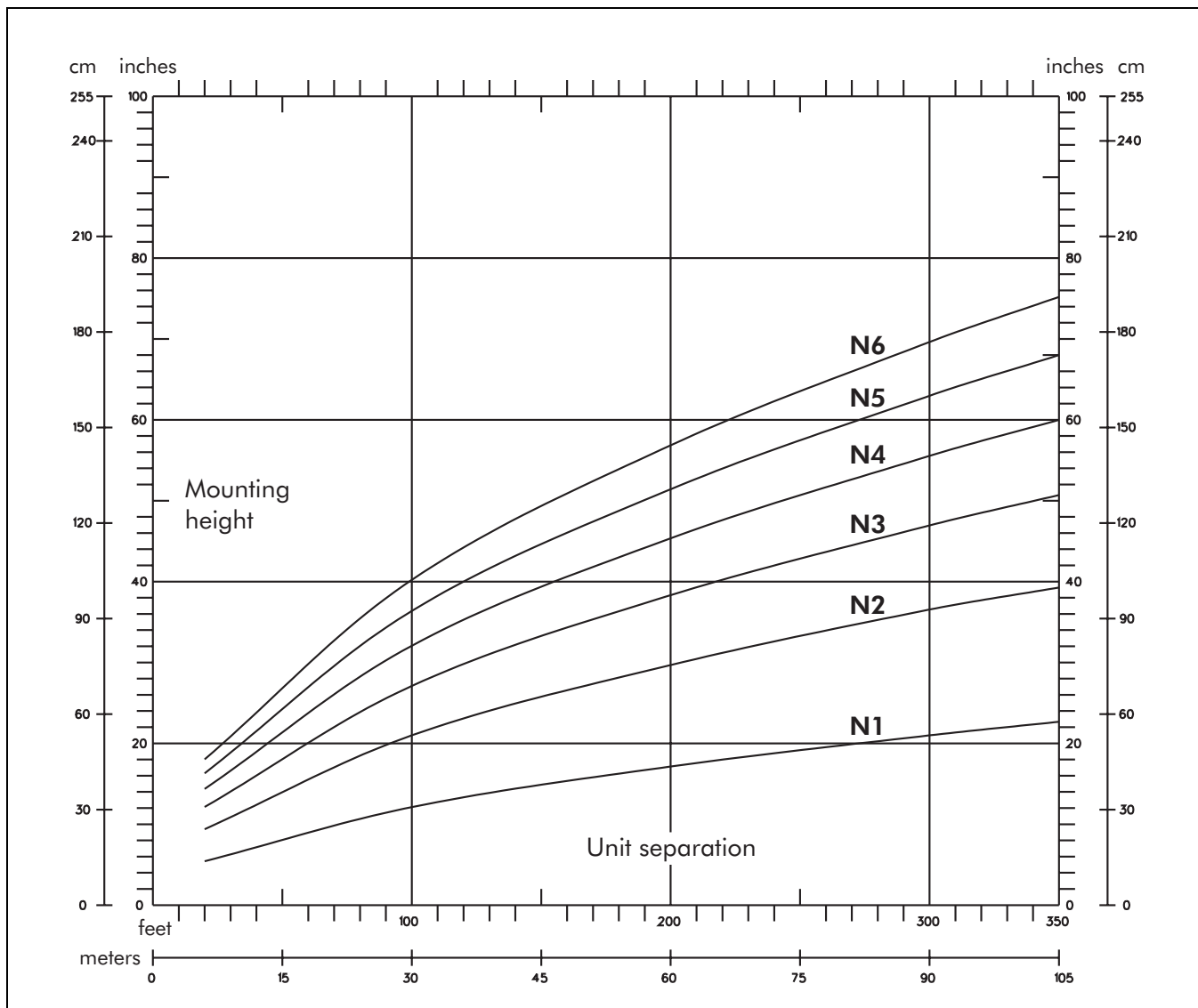

Figure 3-3: Mounting height chart

# Installation - electrical

## Power supply

A power source of 12 VDC (11 to 15 VDC) is required by both the transmitter and receiver units. It is recommended that primary power be brought to the base of each unit's mounting post and terminated in a weatherproof enclosure. This weatherproof enclosure may then be used as a convenient junction box between the transmitter and receiver, the primary power, and the alarm reporting panel. 115 VAC power must not be brought into the enclosures of either the transmitter or receiver units. Refer to Installation - mechanical for installation of a junction box to house the primary power supply.

*CAUTION: When using one DC power supply to power more than one system, insure the wiring between the power supply and the unit is sufficient to prevent the input voltage at the unit from dropping below 11 VDC, when the receivers are not in alarm (maximum current draw).*

## Transmitter wiring

Refer to Figure 3-4 for a wiring diagram of the transmitter unit. It is suggested that an installation wiring diagram be made before wiring the transmitter. This will standardize the wiring of transmitters in a multiple system installation.

### Power source

Terminals 1 and 2.

The transmitter requires 12 VDC (11 - 15 VDC) to operate. Terminal 1 is negative, terminal 2 is positive.

### Tamper reporting

Terminals 3, 4 and 5

The 12 VDC power supply to the transmitter may be connected so that when the electronic enclosure is opened, the transmitter is disabled and the receiver goes into constant alarm. To have a specific tamper alarm report, wire the tamper reporting signal directly onto Terminals 3 & 4 or 4 & 5, and wire power directly to Terminals 1 and 2. Use a twisted/shielded pair of 18 AWG wire for the tamper signal wiring. This wire should be run from the dry contact tamper output terminals to the junction box, and on to the alarm reporting panel.

### Junction box

A tamper switch installed in the power supply junction box may also be wired for tamper reporting. This is done in conjunction with the electronic enclosure tamper wiring and both are connected to the alarm reporting panel.

### Remote self test

Terminal 6 or 7.

The transmitter is capable of providing a test signal that will dynamically test the detection zone to the sensitivity required of that zone. This capability can be remotely activated by applying a +5 to +15 VDC voltage at terminal 6 of the terminal board, or by applying a ground to terminal 7 of this terminal board. A shielded 18 AWG wire should be used for this connection regardless of the self test actuation method used.

### Transmitter ground connection

Connect TB1 terminal(s) 8/9 to a properly installed ground rod.

*NOTE: Senstar-Stellar recommends using a low resistance (5  $\Omega$  or less) earth ground connection at the transmitter unit. Consult the local electrical codes for additional grounding information.*

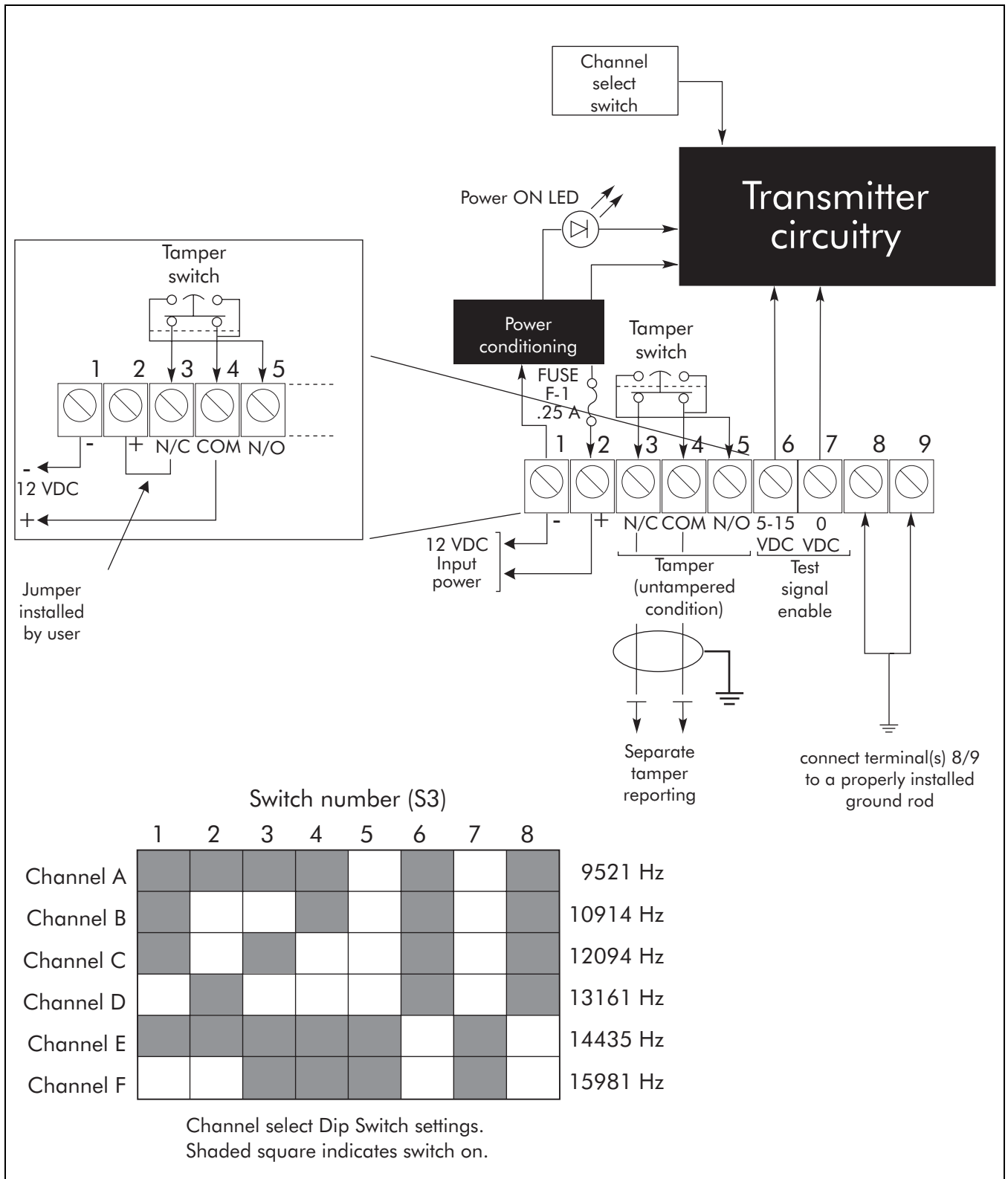

Figure 3-4: Transmitter wiring

# Receiver wiring

Refer to Figure 3-5 for a wiring diagram of the receiver unit. It is suggested that an installation wiring diagram be made before wiring the receiver. This will standardize the wiring of receivers in a multiple system installation.

## Power source

Terminals 1 and 2.

The receiver unit requires 12 VDC (11 to 15 VDC). Terminal 1 is negative, terminal 2 is positive.

## Tamper reporting

Terminals 3, 4 and 5.

### Non-Specific alarm (series tamper alarm)

You may wire the receiver tamper switch (terminals 3 & 4 or 4 & 5) in series or parallel (depending on alarm relay logic) with the alarm contacts for a non-specific alarm report. A non-specific alarm report does not indicate whether an alarm was caused by intrusion detection or tampering with the unit electronic enclosure. A twisted/shielded pair of 18 AWG wire should be used for this connection.

### Specific tamper reporting

To have a specific tamper alarm report, wire the tamper reporting signal directly onto Terminals 3 & 4 or 4 & 5. Use a twisted/shielded pair of 18 AWG wire for the tamper signal wiring. This wire should be run from the dry contact tamper output terminals to the junction box, and on to the alarm reporting panel.

## Alarm circuit

Terminals 6, 7, 8, 9, 10, and 11.

There are two sets of normally open and normally closed dry relay contacts. One set may be used for alarm annunciation at the alarm reporting panel. The other could be used for local annunciation, zone certification testing, etc. Use a twisted/shielded pair of 18 AWG wire to connect the alarm notification to the junction box and alarm reporting panel.

## Multipath sidetone

Phono plug adjacent to Terminal 12.

This is an audio output (2 mW, 600 $\Omega$ ) whose frequency and amplitude are proportional to the amount and location of a source of motion within the detection zone. It can be used as a local test signal, or can be amplified and connected to the alarm monitoring system. Shielded 18 AWG audio wire should be used to connect this signal to the annunciator. A phono jack adapter and an amplified speaker can be connected to the phono plug and used as an aid in aligning the system.

## Receiver ground connection

Connect TB1 terminal 12 to a properly installed ground rod.

*NOTE: Senstar-Stellar recommends using a low resistance (5  $\Omega$  or less) earth ground connection at the receiver unit. Consult the local electrical codes for additional grounding information.*

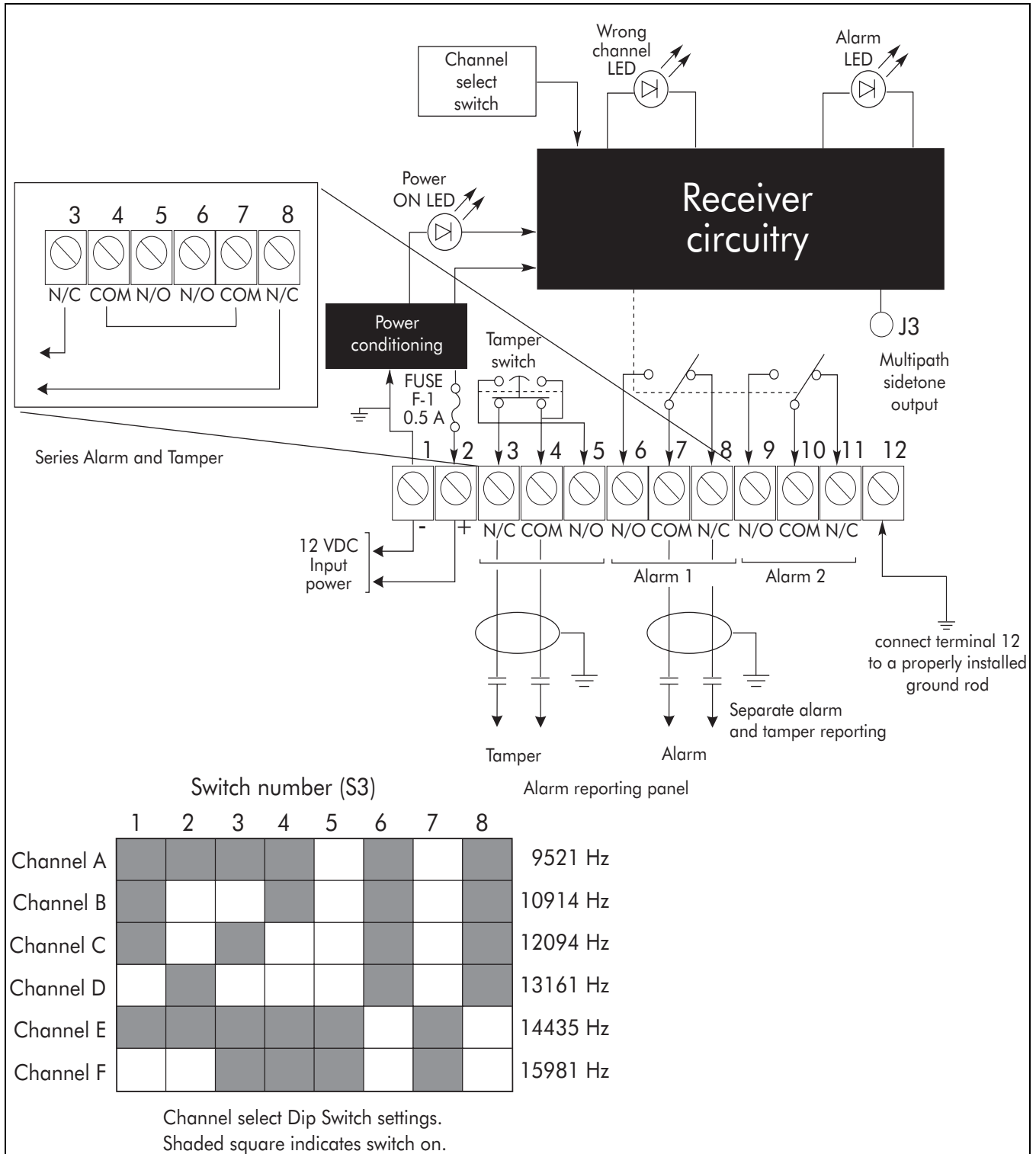

Figure 3-5: Receiver wiring



# 4

# *Operating instructions*

---

Once the following preliminary check, alignment, and sensitivity adjustments are accomplished, the Series 24000 Intrusion Detection System is ready to operate. There are no controls or indicators for operating the sensor system, and no alternate operating modes during emergency conditions.

## **Preliminary check**

Once the sensor system is mounted and wiring installation completed, a preliminary check, channel selection, and antenna pattern selection is required before applying power to the system.

## **Channel select switch**

Refer to the Channel Selection Matrix Chart on the Receiver and Transmitter Wiring illustrations. The channel select switch on each transmitter/receiver pair must be set to the same operating channel. See Figure 3-4 (transmitter) or 3-5 (receiver) for proper settings.

## **Range switch**

This is a small jumper on the receiver circuit board located by the coax input from the antenna. Put this jumper in the "S" position for separation distances of less than 30.5 m (100 ft.); use the "L" position for ranges greater than 30.5 m (100 ft.).

## **Latch/Timed jumper**

This is a white jumper wire located adjacent to terminals 9, 10 & 11 on the receiver circuit board. When the jumper is in the TIMED position, the alarm duration is controlled by the setting of R76 DURATION, which is user-adjustable between 0.5 and 10 seconds.

In the LATCH position, once the system goes into alarm, it will stay in alarm until the jumper is moved to the TIMED position. This jumper must be in the TIMED position for normal operation; the LATCH position is used during electrical alignment of the system.

## Sensitivity jumper

The position of the Sensitivity Jumper is determined by the application requirements:

- L = Low Security
- M = Medium Security
- H = High Security

(See page 2-1 for definitions of these terms.)

This jumper effectively reduces the maximum alarm sensitivity, preventing excessive sensitivity that may result in nuisance alarms.

## Antenna pattern

The detection pattern is adjustable by use of the sensitivity adjustment, and by changing the configuration of the transmitting and receiving antennas. The antenna configuration is changed by installing RF absorbent pads over selected antenna elements (see Figure 4-1). When no antenna pads are installed, the microwave beam is narrowest (7°). With sixteen of the elements covered, the beam is 11°. With thirty-two of the elements covered, the pattern is 16°. In general, the wide pattern should only be used when the separation distance between receiver and transmitter is 15 m (50 ft.) or less. The medium range pattern should be used (if necessary) with separation distances of between 15 m (50 ft.) and 30.5 m (100 ft.). The narrowest pattern (unmodified antenna) must be used when the separation distance is greater than 30.5 m (100 ft.).

*NOTE: Always use the narrowest beam possible, commensurate with detection requirements.*

Install the absorbent pads on both the receiver and transmitter pair in accordance with the following instructions:

1. Select the number of strips of double-backed tape that will cover the elements necessary to provide the desired detection pattern. Remove the paper backing, and stick the tape over the elements to be covered.

*Note: Cover only the elements shown in the illustration (Figure 4-1).*

2. Remove the other piece of paper backing from the tape, and firmly press the RF absorbent material to it.
3. Ensure that both the transmitting antenna and the receiving antenna configurations are identical.



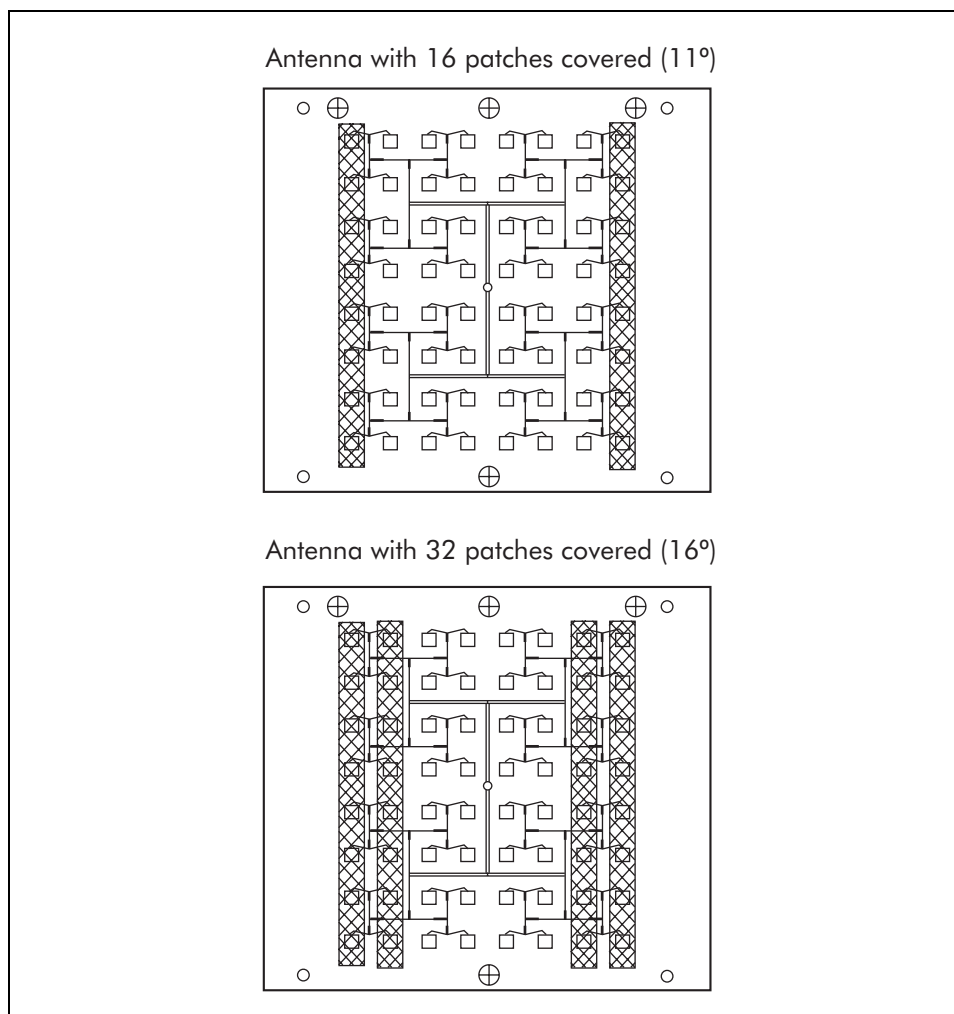

Figure 4-1: Antenna patterns

## Electrical alignment

An electrical alignment requires the antennas of both the transmitter and receiver units to be aimed head-to-head. Verify initial mechanical alignment. Once this initial mechanical alignment is done, a more precise electrical alignment is required.

*NOTE: The transmitter/receiver units should never be aimed into the ground or off to the side of the detection zone. However, discontinuities in the detection zone may dictate an alignment slightly off head-to-head.*

*NOTE: During this alignment procedure, place the LATCH/TIMED jumper on the receiver circuit board in the LATCH position. This will speed up the response time of the AGC voltage to make the adjustment easier.*

## **AGC measurement**

At the receiver, connect a digital voltmeter between TP-10 (+) and TB1-1 (-). This is the automatic gain control (AGC) voltage. After final alignment, as outlined below, the AGC voltage should be between 1.7 and 7.3 VDC. Put the SHORT-LONG jumper in the LONG position to increase the AGC voltage. Put the SHORT-LONG jumper in the SHORT position to decrease the AGC voltage.

## **Receiver**

Slowly move the receiver unit up and down the post while monitoring the receiver AGC voltage. Once a maximum AGC voltage is obtained, rotate the receiver until maximum AGC is obtained on this axis. Tilt the receiver antenna up and down, again adjusting for maximum AGC voltage.

## **Transmitter**

Continue to monitor the AGC voltage at the receiver while moving the transmitter in all three axes as described for the receiver, until maximum AGC voltage is obtained.

## **Final alignment**

Before securing the hardware, repeat the transmitter and receiver unit electrical alignment steps for obtaining maximum AGC reading on all rotational axes.

## **Secure hardware**

Secure the mounting nuts and bolts. Ensure the AGC voltage remains high while this hardware is tightened. If the final AGC voltage is greater than 4.0 volts, put the SHORT-LONG jumper in the SHORT position; this will reduce the voltage to the 2.5 to 3.0 volt range. Put the LATCH/TIMED jumper into the TIMED position for normal operation.

---

## Sensitivity adjustment

Before beginning a sensitivity adjustment, make sure the receiver “ALARM” LED is not lit. Connect an ohmmeter between TB1 - terminals 10 and 11. It will read less than 0.5 ohms when the system is operational (armed) and infinity when the unit is in alarm. Leave the ohmmeter connected.

### Alarm test

A preliminary alarm test requires walking across the detection zone to ensure the unit goes into alarm (“ALARM” LED lit, ohmmeter to infinity). If it does not, adjust the sensitivity potentiometer (R55) clockwise; then walk test the zone again. An alarm report should normally occur before a line of sight between the transmitter and receiver units is broken by the walker.

### Final alarm test

Determine the level of security sensitivity desired, and then use the following parameters for ensuring that the level desired is present:

*NOTE: Start with the sensitivity jumper in the “L” position - change to “M” or “H” if unable to get the required detection with adjustment of R55 alone. The final adjustment setting should be the lowest setting possible that provides the required detection.*

**Low security** - walk across detection zone in every area intrusion concern is present. Adjust R55 for consistent detection.

**Medium security** - crawl on hands and knees in all detection zone areas of intrusion concern. Adjust R55 for consistent detection.

**High security** - pull metal sphere (see Tools on page 3-2); pull often enough to give confidence that the zone has the sensitivity you want.

### High security

Adjustment for a typical high security application requires the detection of a prone human crawling through the detection zone with the length of the body parallel to the line of sight. A 30.5 cm (12 in.) metal sphere represents approximately the same target to the microwave sensor. When adjusting the sensitivity to high security specifications, slowly (13 cm {5 in.} per second or faster) pull the sphere through the zone (perpendicular to the line of sight) approximately every 3 m (10 ft.) and adjust the sensitivity potentiometer (R55) until repeatable detection is obtained.

*NOTE: Dragging the sphere in the offset area is not necessary.*



# 5

# Troubleshooting

---

The following are procedures for troubleshooting the Series 24000 Intrusion Detection System. If, after checking out these conditions, you find your system is still not functioning, then the possibility of a faulty condition on another system on the premises besides the Series 24000 is very likely.

## Return for repair procedures

A Return Material Authorization number (RMA) must be obtained from Senstar-Stellar before any items will be accepted for return. Please contact Senstar-Stellar Customer Service to obtain this authorization.

When contacting Customer Service, you will need your Model number, Serial number, and the date of purchase. Please have this information available before you make your request for return.

## Nuisance alarm

Nuisance alarms are usually attributed to physical problems within the detection zone. Refer to the Site planning & design section of the guide, and review the conditions inherent to causing nuisance alarms. If these alarms persist, note time and conditions of each alarm - is there a physical feature of your detection zone that occurs at certain times, i.e., traffic or train going by, etc.?

## Continuous alarm

Continuous alarms are more likely to be an equipment-related problem than a detection zone problem. First, determine if the sensor system is aligned and adjusted for appropriate sensitivity. Refer to the Operating instructions section of the guide, and review the conditions causing continuous alarms. Check to make sure the alarm relay LATCH/TIMED jumper (white wire) is in the "TIMED" (T) position. Remove external wires from the receiver unit circuit board terminal 6 or 8, and measure ohms on the relay contact. Then, proceed to Board level test points on page 5-2, and test the transmitter/receiver circuit boards.

An "alarm" situation may also occur if power to the system is being interrupted. Check both the primary power source and all terminal connections for the DC power.

## No alarm

Check the alarm relay to verify it is working. Remove external wires from the receiver unit circuit board terminal 6 or 8, and measure ohms on the relay contact. Also check the receiver circuit board with the test points listed in the Board level test points.

## Test points

The boards containing the electronic circuitry in the transmitter/receiver unit enclosures may be tested for readings required for normal operation of the system. Figures 5-1 (receiver) and 5-2 (transmitter) show the location of the test points on the boards. These tests should be done under the following conditions:

1. 12 VDC (nominal) power applied to both transmitter and receiver units.
2. The same channel selection for both transmitter and receiver.
3. Mechanical (transmitter to receiver) alignment complete.
4. Obtain “normal indication” for each test/observation before proceeding to the next test point.
5. All measurements require a digital multi-meter (DMM) except where an oscilloscope reading is indicated.

### Board level test points

Test point observation	Normal indication	Cause for abnormal reading
<b>Transmitter:</b>		
TP-9	11.6 VDC $\pm$ 0.25 (@ 12 VDC input)	1. Fuse F1 blown 2. No power to TB-1 terminals 1 (-) and 2 (+), (11 - 15 VDC)
Power LED (DS-1)	Illuminated	1. LED open 2. Voltage regulator U5 open
TP-5	6.0 VDC $\pm$ 0.5	Voltage regulator U11 faulty
TP-8	5 - 8 V P-P Oscilloscope reading (clean and symmetrical square wave)	1. Power amplifier faulty 2. Code generator faulty
<b>Receiver:</b>		
TP-1	11.6 VDC $\pm$ 0.25 (@ 12 VDC input)	1. Fuse F1 blown 2. No power to TB-1 terminal 1 (-) and 2 (+), (11 - 15 VDC)
TP-3	5.0 VDC $\pm$ 0.1	1. Regulator U15 failure 2. DS-3 Power LED open
TP-2	8.0 VDC $\pm$ 0.1	Regulator U15 failure
TP-4	2.5 VDC $\pm$ 0.1	Zener diode D9 failure
TP-10	1.7 - 7.3 VDC	1. Channel selection not correct 2. Mechanical alignment improper 3. Transmitter not operating properly 4. Receiver circuits faulty
Alarm LED (DS-2)	Non-illuminated	1. Channel selection not correct 2. Mechanical alignment improper 3. Transmitter not operating properly 4. Receiver circuits faulty
Wrong channel LED (DS-1)	Non-illuminated	1. Channel selection at Tx/Rx not identical 2. Object in path 3. Faulty transmitter 4. Faulty receiver

Table 5-1: test point readings

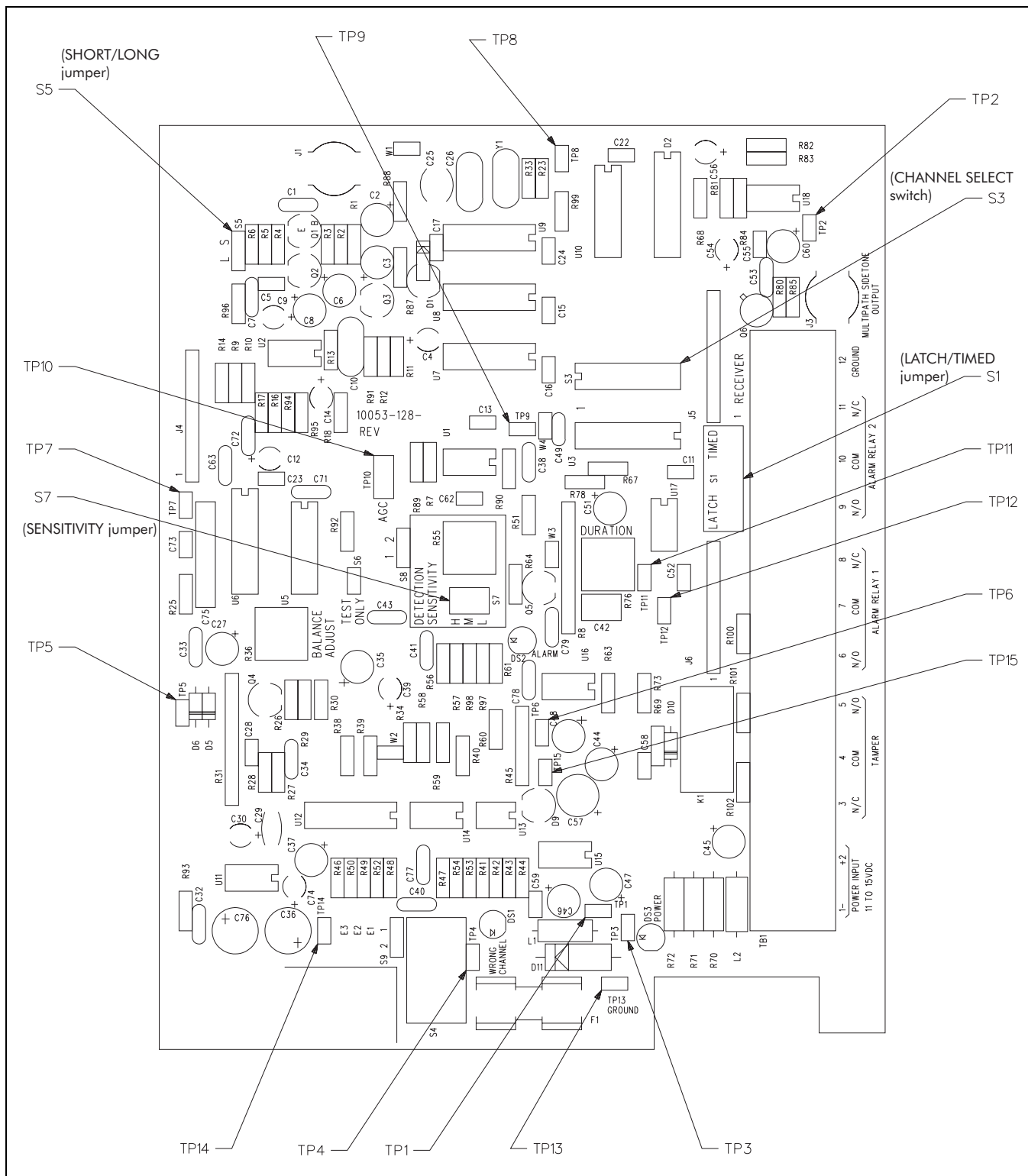

Figure 5-1: Receiver PCB

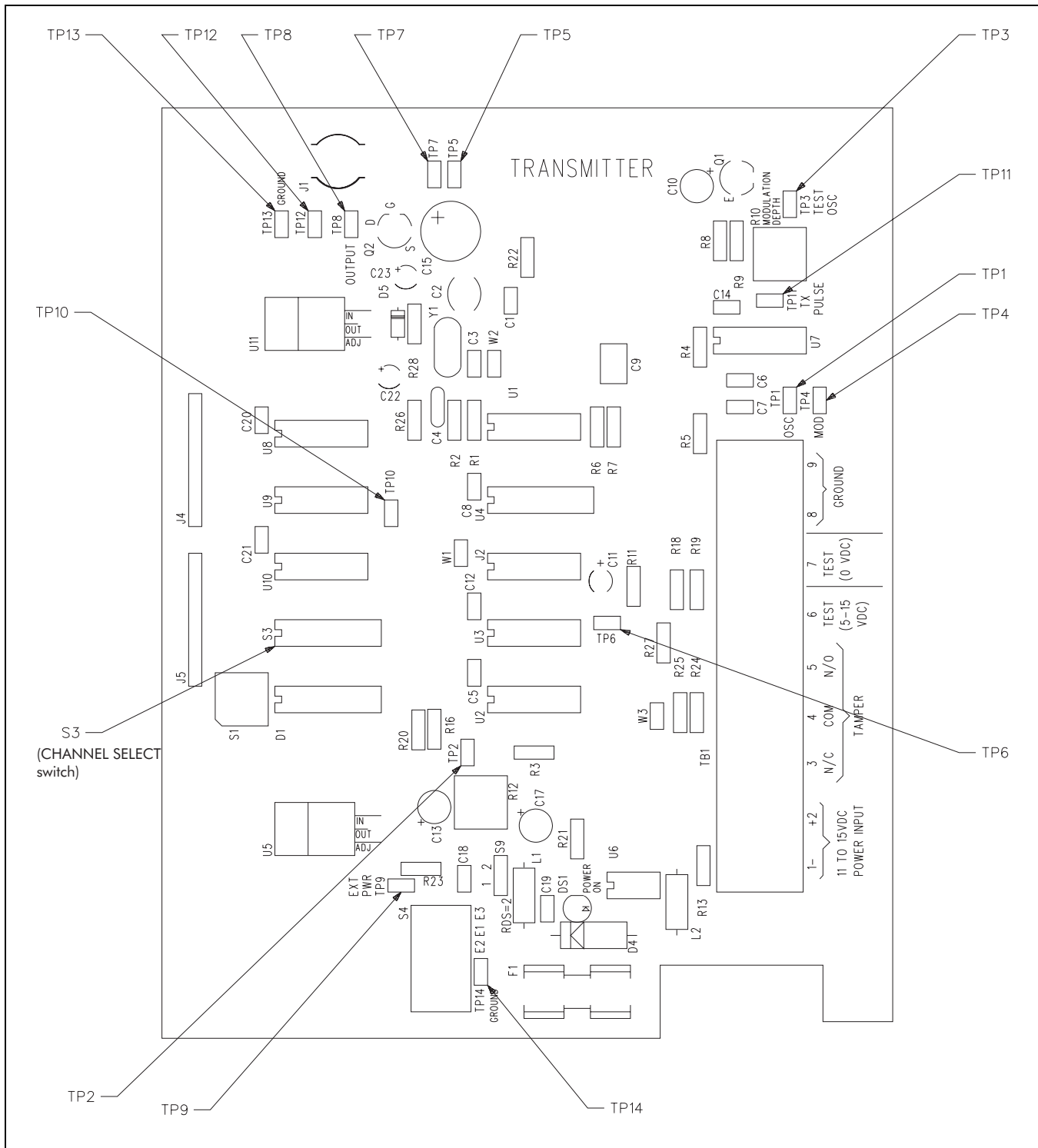

Figure 5-2: Transmitter PCB

Figure 5-3 is a functional block diagram of the Series 24000 receiver unit.



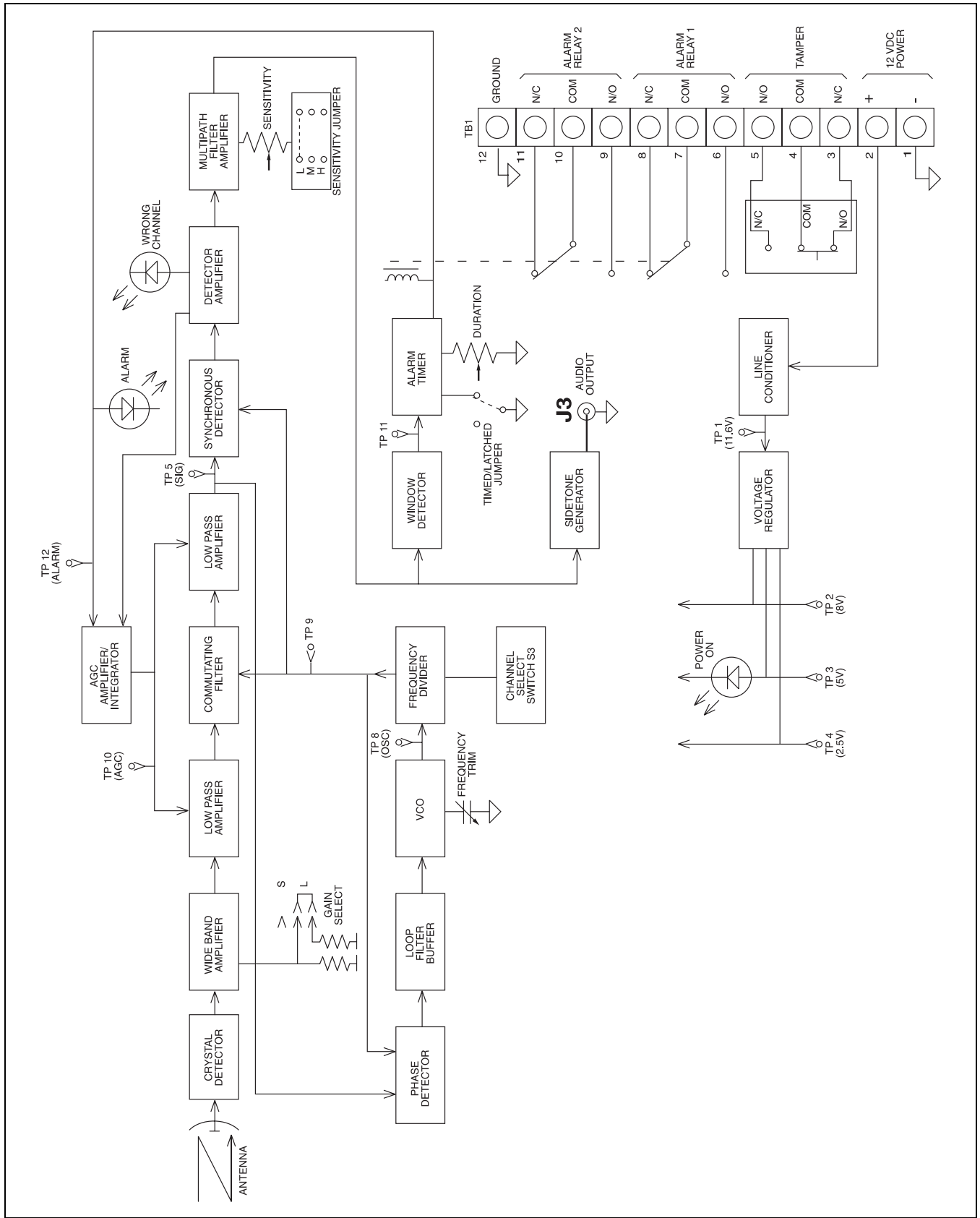

Figure 5-3: Receiver block diagram

Figure 5-4 is a functional block diagram of the Series 24000 transmitter unit.

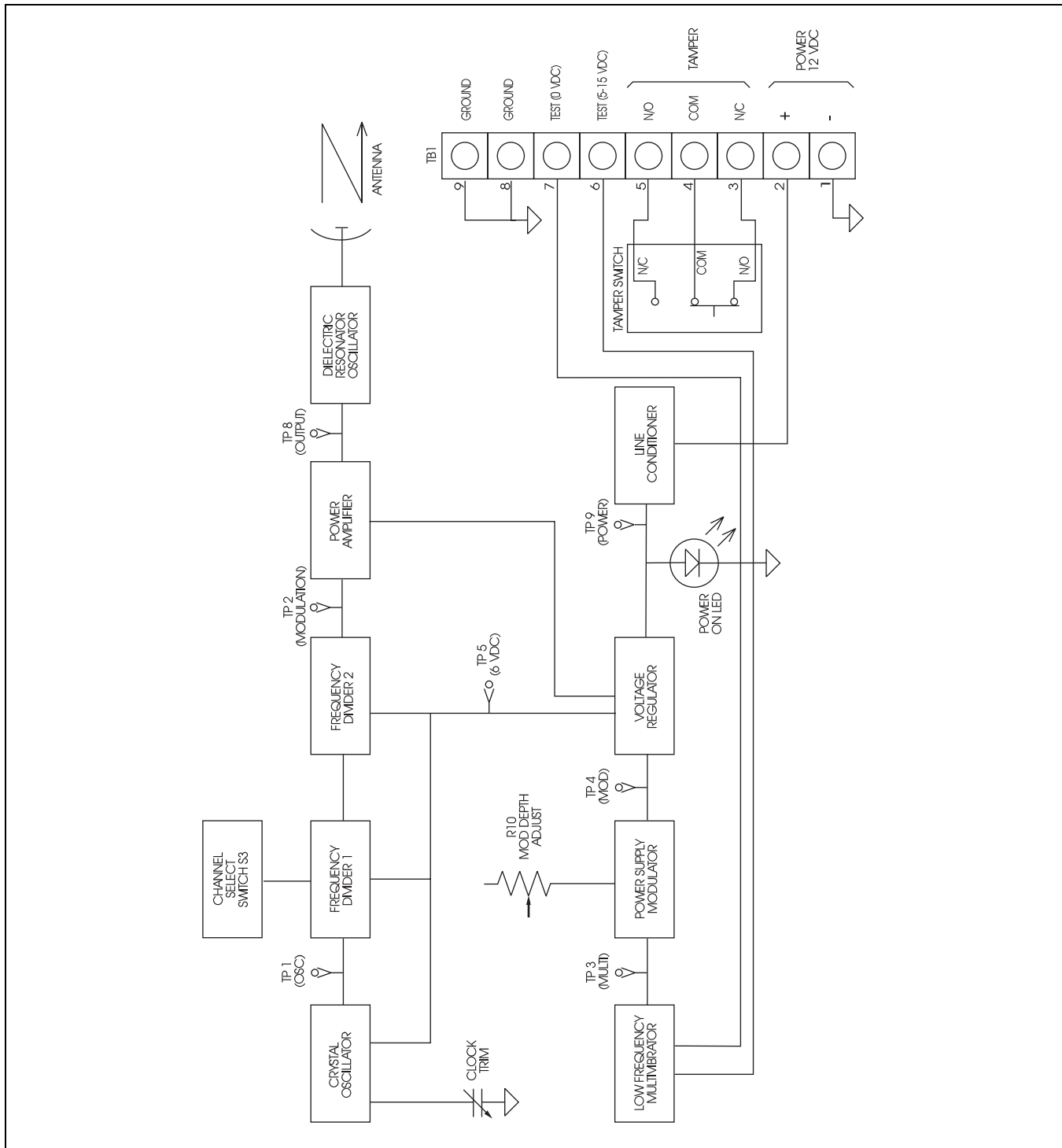

Figure 5-4: Transmitter block diagram

<b>General</b>	<b>Voltage requirements</b>	<ul style="list-style-type: none"> <li>• 11 - 15 VDC</li> </ul>
	<b>Current requirements</b>	<ul style="list-style-type: none"> <li>• 150 mA total per system (maximum)</li> </ul>
	<b>Operating range</b>	<ul style="list-style-type: none"> <li>• 3 to 150 m (10 to 492 ft.)</li> </ul>
	<b>Dimensions</b>	<ul style="list-style-type: none"> <li>• width - 16 cm (6.25 in.)</li> <li>• depth - 9 cm (3.375 in.)</li> <li>• height - 31 cm (12.25 in.)</li> </ul>
	<b>Weight</b>	<ul style="list-style-type: none"> <li>• 0.9 kg (2 lbs.)</li> </ul>
	<b>Model 24001</b>	<ul style="list-style-type: none"> <li>• standard unit for commercial applications</li> </ul>
	<b>Model 24004</b>	<ul style="list-style-type: none"> <li>• High reliability unit for high security applications - Fully documented and traceable acceptance test program. Fully tested (burned in) at high and low temperature extremes.</li> </ul>
<b>Transmitter</b>	<b>Operating voltage &amp; current</b>	<ul style="list-style-type: none"> <li>• 11 - 15 VDC, 120 mA maximum</li> </ul>
	<b>Microwave carrier frequency</b>	<ul style="list-style-type: none"> <li>• 24.125 GHz <math>\pm</math> 50 MHz (K-band)</li> </ul>
	<b>Microwave output</b>	<ul style="list-style-type: none"> <li>• less than 2.5 volts per meter, maximum at 30 m (98 ft.)</li> </ul>
	<b>Operating range</b>	<ul style="list-style-type: none"> <li>• ingress/egress: 150 m (492 ft.)</li> </ul>
	<b>Separation distance</b>	<ul style="list-style-type: none"> <li>• transmitter/receiver - high security 100 m (328 ft.)</li> <li>• transmitter/receiver - low security 150 m (492 ft.)</li> </ul>
	<b>Antenna pattern (adjustable)</b>	<ul style="list-style-type: none"> <li>• short range - 16°</li> <li>• medium range - 11°</li> <li>• long range - 7°</li> </ul>
	<b>Antenna polarization</b>	<ul style="list-style-type: none"> <li>• E-plane, vertical (E-plane horizontal - optional)</li> </ul>
	<b>Modulation</b>	<ul style="list-style-type: none"> <li>• type: square wave, type A2</li> <li>• channels: 6 field-selectable sub-carriers</li> </ul>
	<b>Tamper circuit contact rating</b>	<ul style="list-style-type: none"> <li>• 1 A, 28 VDC</li> </ul>
	<b>Operating temperature</b>	<ul style="list-style-type: none"> <li>• -40° to +66°C (-40° to +150° F) - Model 24001</li> </ul>

<b>Receiver</b>	<b>Operating voltage &amp; current</b>	<ul style="list-style-type: none"> <li>• 11 - 15 VDC, 30 mA maximum</li> </ul>
	<b>Microwave receiver frequency</b>	<ul style="list-style-type: none"> <li>• 24.125 GHz</li> </ul>
	<b>Antenna pattern (adjustable)</b>	<ul style="list-style-type: none"> <li>• short range - 16°</li> <li>• medium range - 11°</li> <li>• long range - 7°</li> </ul>
	<b>Antenna polarization</b>	<ul style="list-style-type: none"> <li>• E-plane, vertical (E-plane horizontal - optional)</li> </ul>
	<b>Demodulation</b>	<ul style="list-style-type: none"> <li>• type A2 - 6 field-selectable sub-carriers</li> </ul>
	<b>Alarm relay contact rating</b>	<ul style="list-style-type: none"> <li>• 2 A @ 28 VDC</li> </ul>
	<b>Alarm delay</b>	<ul style="list-style-type: none"> <li>• adjustable 0.5 sec. to 10 sec.</li> </ul>
	<b>Tamper circuit contact rating</b>	<ul style="list-style-type: none"> <li>• 1 A, 28 VDC</li> </ul>
	<b>Audio output</b>	<ul style="list-style-type: none"> <li>• balanced 600 ohms, output proportional to size and velocity of radar target, 2 mW max.</li> </ul>
	<b>Operating temperature</b>	<ul style="list-style-type: none"> <li>• -40° to +66°C (-40° to +150° F) - Model 24001</li> </ul>



# ***Application notes***

The following application notes provide additional information about the Series 24000 bi-static microwave intrusion detection system:

- Application note # 1 - Do's and Don'ts: a planning primer
- Application note # 2 - Stacking bistatic microwaves



# Intelli-WAVE

& Series 14000, 16000 and 24000 Microwaves

Application Note #1

June 24, 2002

E6DA0109-001, Rev A

## DO's and DON'Ts: a planning primer

### Introduction

The purpose of this Application Note is to outline the “rules” for bistatic microwaves, to allow for the successful installation and operation of microwave units.

Bistatic microwave sensors have been used in security applications for many years. They operate successfully, as long as the “rules” for bistatic microwaves are understood and followed by the planner/consultant, the installer and the end-user. These “rules” include limitations in site coverage and detection capability, as well as the critical need for proper site preparation. Improper site preparation will result in nuisance alarms and inconsistent detection.

### Microwave basics

A transmitter sends out an electromagnetic wave in the microwave band toward a receiver. The receiver picks up an electromagnetic signal composed of both the direct signal from the transmitter and the reflected signal from the ground and other nearby objects. Any metallic or water-containing (living) conductive object moving within the microwave field alters the received signal in amplitude and phase. The changes in the received signal are analyzed, and if they meet the criteria for object size and speed, an intrusion alarm is declared.

### Microwave detection zone size

The size of the microwave detection zone varies greatly between the transmitter and the receiver. The detection coverage is very small near either unit, typically 15 cm (6 in.) in diameter. Therefore, the areas directly below the transmitter and receiver are unprotected, as indicated in Figure 1. Microwave units MUST be offset to provide complete coverage of these unprotected areas, as indicated in Figures 2, 3 and 4.

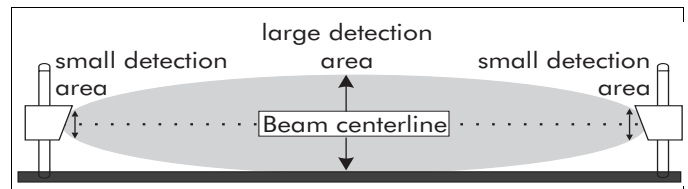

Figure 1: Microwave detection zone

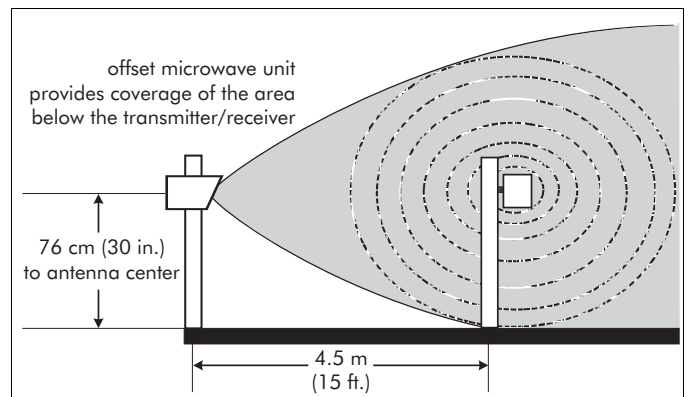

Figure 2: Offset microwave coverage for dead zone

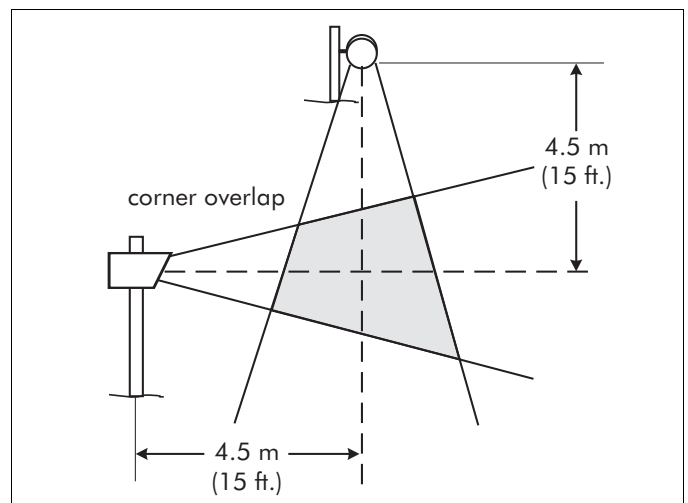

Figure 3: Corner overlap

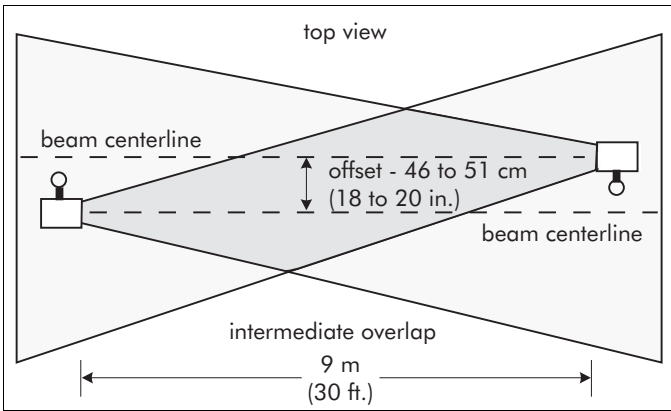

Figure 4: Top View- Intermediate Overlap

The detection coverage is largest midway between the transmitter and receiver. The size of the detection coverage increases as unit separation increases, as indicated in Figure 5.

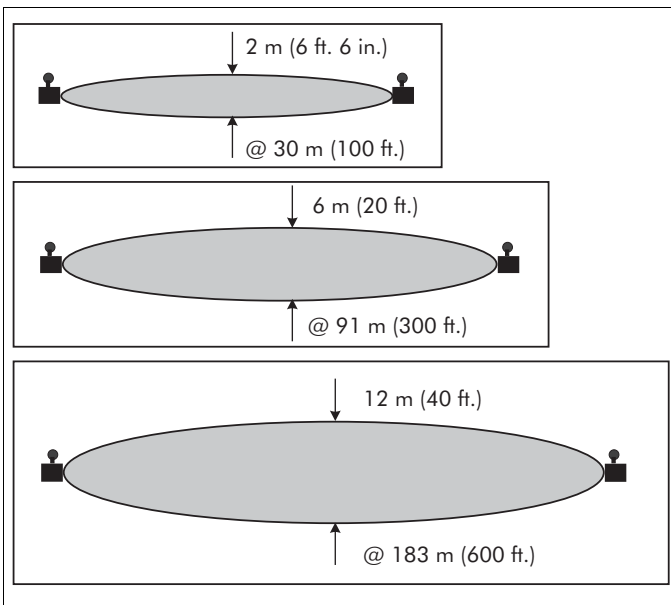

Figure 5: Approximate Intelli-WAVE coverage patterns

The coverage patterns in Figure 5 are for human-size objects. Large metallic objects, like vehicles or moving fence panels, can be detected beyond the indicated envelopes. The pattern is approximately the same horizontally and vertically, creating an elongated cylindrical detection field that is tapered at both ends. However, the pattern does not extend below the surface of the ground.

Detection capability depends on the sensitivity setting, the transmitter/receiver separation and mounting height, and the intruder profile (walking, creeping, crawling, or rolling). For reliable detection of all intrusion profiles, the separation between the transmitter and receiver must not exceed 100 m (328 ft.). This is referred to as a high-security microwave detection zone.

At the maximum separation distance for bistatic microwave units, only upright walking intruders are reliably detected.

Microwave detection is NOT terrain-following. Only line-of-sight detection is provided by bistatic microwaves.

### Unit separation and the mid-point zone width

There is direct relationship between the separation distance of the transmitter and receiver (zone length), and the diameter of the detection envelope at the mid-point of the zone. The approximate beam width relationship for various products is indicated in Table 1.

Product	Beam width relationship
Intelli-WAVE (Model MPS4100)	$BW = ZL \times 0.066$
Microwave Series 14000	$BW = ZL \times 0.018$
Microwave Series 16000	$BW = ZL \times 0.055$
Microwave Series 24000	$BW = ZL \times 0.035$
BW = beam width ZL = zone length (i.e., unit separation)	

The beam width also depends on the sensitivity setting of the receiver. The beam width increases as the sensitivity is increased.

### Physical limitations to the maximum beam width

The beam width formula can be used to calculate the maximum transmitter/receiver separation when there is a physical limitation to the beam width, (for example, when the microwave units are located between two parallel fences, or close to buildings). In this case, the maximum width allowed is divided by the numeric factor to calculate the zone length. For example, if an Intelli-WAVE is being installed between two parallel fences that are 5 m apart, the maximum zone length is equal to 5 m divided by .0066, which equals 76 m. However, because large metallic objects can be detected outside of the envelope, you may have to adjust the sensitivity or reduce the unit separation accordingly.

If the object that must be excluded from the detection envelope is to one side only, then the distance from the beam centerline to the object is determined, and then doubled to provide the maximum allowable beam width. The maximum allowable beam width is then used to calculate the transmitter/receiver separation distance.



## Site Rules - DO's and DON'Ts

- DO use bistatic microwave sensors in clear, flat areas that provide a clean line-of-sight. Bistatic microwave units are line-of-sight sensors that require a reasonably long and flat detection zone.
- DON'T use bistatic microwave sensors in areas where the line-of-sight will be blocked, for example, in parking areas, where fixed objects are inside the beam pattern (out buildings, guard shacks), where power or light poles are in the direct center of beam.
- DO use bistatic microwave sensors in areas where the ground is smooth and flat.
- DON'T use bistatic microwave sensors over drainage ditches, hills, or ungraded areas where there is more than a 15 cm (6 in.) change in terrain over the full length of the zone. Microwave detection is not terrain-following (see Figure 6).

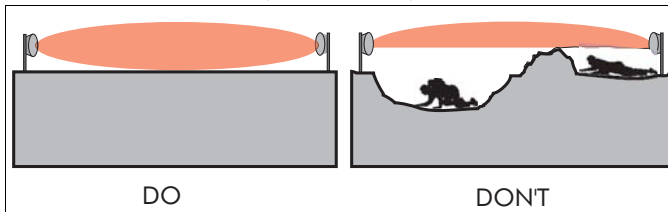

Figure 6: DO's and DON'Ts of installation terrain

- DO use bistatic microwave sensors in areas that are free of extraneous motion.
- DON'T use bistatic microwave sensors in areas with trees, shrubs or vegetation in, or near, the detection zone. Vegetation within the detection zone will cause nuisance alarms.
- DO eliminate all puddles and areas of standing water inside the detection zone.
- DON'T use bistatic microwave sensors near large areas of water, such as ponds, streams, drainage ditches and water runoff areas.
- DO use bistatic microwave sensors in areas that are fenced-in (see Figure 7).
- DON'T use bistatic microwave sensors in unfenced/uncontrolled areas because of potential problems with animal-initiated nuisance alarms.
- Do limit the length of the microwave zone to exclude fences, buildings and other reflective surfaces from inside the detection area. Use additional microwave units to provide complete coverage of the area.
- Don't allow fences, buildings or other reflective objects into the microwave zone or nuisance alarms and inconsistent detection will result.

- DO mount microwave units at least 3 m (10 ft.) in from the fence line for short zones. For longer zones, follow the guidelines for unit separation.
- DON'T mount the microwave unit too close to the fence to protect against bridging attempts, and to avoid nuisance alarms caused by fence movement.

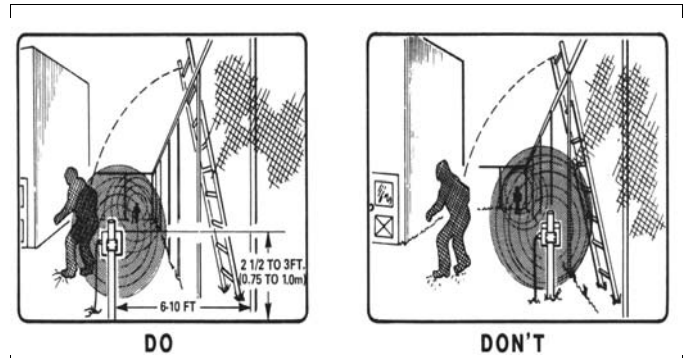

Figure 7: DO's and DON'Ts for fenced-in areas

- DO keep microwave units away from traffic areas, and DO provide protective devices to prevent damage.
- DON'T mount microwave units near fence gates that can swing into the heads.
- DO use microwave offsets and corner overlaps to provide complete coverage of an area, including the transmitter and receiver mounting locations.
- DON'T leave vulnerable areas at the transmitter and receiver mounting locations.

## Ground cover rules for reliable detection

- The transmitter/receiver separation distance must not exceed 100 m (328 ft.) for high-security applications.
- The transmitter and receiver units are to be mounted with the beam centerline (center of antenna) 60 to 75 cm (24 to 30 in.) above the ground (according to the unit's installation instructions).
- Terrain within the detection zone must be level to grade, plus or minus 7.5 cm (3 in.).
- Terrain within the detection zone must be completely covered with crushed rock (2 cm (0.75 in.) maximum) to a depth of 10 cm (4 in.). Crushed rock allows for the proper drainage of rainwater and prevents the formation of puddles.
- For areas where snow accumulates, pavement is the recommended surface, to allow for easy snow removal. Snow build-up can cause changes in the microwave pattern, which can result in nuisance alarms. Remove snow, as it accumulates.

- The detection zone must be completely free from vegetation, for the full width of the microwave pattern.
- Perform all routine site maintenance, as required.

## Low-security applications

For low security applications where only upright walkers must be detected, the following ground covers are acceptable: well-mown grass (7.6 cm (3 in) or less), asphalt, concrete, or hard-packed soil.

## Rules for areas with significant snow accumulation

The accumulation of snow in the detection zone between the transmitter and receiver reduces their effective mounting height. The reduction in mounting height changes the ground reflection characteristic, which greatly affects the received signal level. Therefore, it is strongly recommended that snow be removed from inside the microwave zones.

There are additional problems arising from the accumulation of snow:

- If the snow blocks the line-of-sight from transmitter to receiver, the zone stops working.
- Snow drifts may produce “radar shadows”, thereby increasing vulnerability.
- Intruders can burrow into the snow to avoid detection.

If snow removal is impractical due to site conditions, the following procedure should be followed when installing the microwave sensor:

1. Select the unit’s mounting height from the unit separation/mounting height charts included on page 4 of Intelli-WAVE Application Note #2, *Stacking bistatic microwave units*, so that the operating point is approximately half-way between two nodal lines. At this mounting height the received signal will be close to the minimum level.

2. Check the alignment.  
For Intelli-WAVE, if the received signal is adequate (LED 6 or greater on the alignment aid, or a voltage measurement of 2.5 VDC at tp6 and tp12) the selected mounting height is correct.

OR

If the received signal is below the minimum acceptable levels, reduce the mounting height in small increments, until the signal level is adequate.

3. Ensure that the units are in correct line-of-sight adjustment.

This procedure will provide the greatest possible margin for snow accumulation. However this will NOT provide optimum system performance under normal conditions.

## Post mounting and grounding

Each transmitter and receiver is mounted on a 7.6 to 10 cm (3 to 4 in.) steel post, depending on the hardware supplied. Each post is installed in a concrete base that is at least 61 cm (24 in.) in diameter and 91 cm (36 in.) deep, OR 15 cm (6 in.) below the frost line, whichever is greater. The microwave units must be securely fixed, and must not move when the wind blows, or when the ground freezes and thaws.

At each transmitter and receiver location, a proper ground rod must be installed according to local electrical codes. The ground rod must be connected to the unit according to the installation instructions.

## Further references

- Installation and Operation Guides for Intelli-WAVE, Series 14000, Series 16000 and Series 24000
- “General Principles of Microwave Motion Detection”
- “Increasing the Utility of Bistatic Microwave Intrusion Detection Systems”, Greg Baxter, 1990
- Intelli-WAVE Application Note # 2, Stacking bistatic microwave units

Contact Senstar-Stellar Corporation to obtain copies of the above listed material.

# Senstar Stellar

Senstar-Stellar Corporation  
119 John Cavanaugh Drive  
Carp, Ontario  
Canada K0A 1L0  
Telephone: +1 (613) 839-5572  
Fax: +1 (613) 839-5830

Senstar-Stellar, Inc.  
43184 Osgood Road  
Fremont, CA  
USA 94539  
Telephone: +1 (510) 440-1000  
1-800-676-3300  
Fax: +1 (510) 440-8686

Senstar-Stellar Limited  
Orchard House  
Evesham Road  
Broadway, Worcs.  
U.K. WR12 7HU  
Telephone: +44 (1386) 834433  
Fax: +44 (1386) 834477

Senstar GmbH  
Riedheimer Str. 8  
88677 Markdorf  
Germany  
Telephone: +49 (7544) 95910  
Fax: +49 (7544) 959129

Senstar-Stellar Latin America  
Pradera No. 214  
Col. Pradera  
Cuernavaca, Morelos  
62170, Mexico  
Telephone: +52 (777) 313-0288  
Fax: +52 (777) 317-0364

Website: [www.senstarstellar.com](http://www.senstarstellar.com)

email: [info@senstarstellar.com](mailto:info@senstarstellar.com)

Senstar-Stellar and the Senstar-Stellar logo are trademarks of Senstar-Stellar Corp. Copyright © 2002. All rights reserved.  
The information in this application note is subject to change without notice. Printed in Canada.

# Intelli-WAVE

& Series 14000, 16000 and 24000 Microwaves  
Application Note #2

September 27, 2002  
E6DA0209-001, Rev B

## Stacking bistatic microwave units

### Introduction

Bistatic microwave sensors have been used in security applications for many years. Typically, microwave sensors provide a detection zone with a limited height. One method of increasing the height of the detection zone is to stack two transmitter-receiver pairs, with one pair mounted above the other (see figure 1). This method of stacking microwave sensors can be used to detect bridging attempts made with ladders or other climbing apparatus.

This Application Note outlines some of the advantages and disadvantages of stacking the Intelli-WAVE (Model MPS 4100), Series 14000, Series 16000, and Series 24000 microwave sensors.

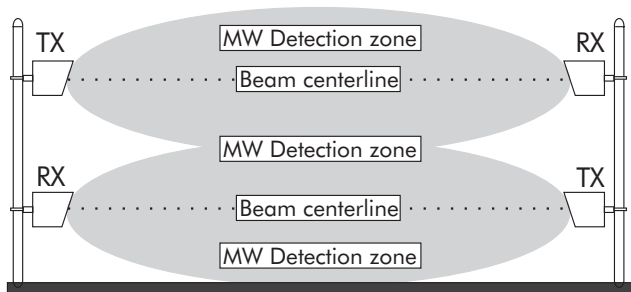

Figure 1: Stacked standalone microwave detection zones

### Good practice

Follow the rules for site preparation, ground cover, clearances and unit separation, as outlined in the Intelli-WAVE Application Note #1 - *DO's and DON'Ts: a planning primer*.

The following steps **MUST** be taken in order to stack two microwave sensors:

1. Ensure that the two pairs have **DIFFERENT** modulation frequencies.
2. Ensure that the two pairs have **DIFFERENT** polarizations for the microwave signal. This will

help prevent interference between the two sets of microwave units.

- Order one pair with antenna elements rotated 90 degrees, or with Intelli-WAVE, rotate the antennae prior to installation.
  - The lower pair should have horizontal polarization (wide beam), and the upper pair should have vertical polarization (narrow beam).
3. For stand-alone (single zone) or perpendicular zone configurations, install one transmitter and one receiver on each post (see Figure 1). Ideally, the two pairs fire in opposite directions. Alternatively, the two transmitters or two receivers can be installed on the same post (see Figure 2). Generally, the choice is dictated by site wiring considerations.
  4. For multiple in-line zones, mount 2 transmitters on one post, and 2 receivers on another (see Figure 2). Ensure that the modulation frequencies and polarizations of the 2 units on each post are different.

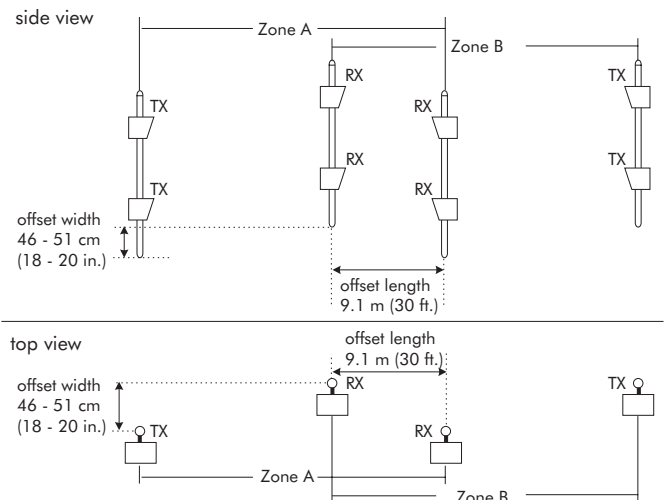

Figure 2: Stacked multiple in-line microwave detection zones

5. For multiple zone configurations, carefully plan the layout, ensuring that there are no possible conflicts or interference in modulation frequency or polarization.
6. Use a minimum 10 cm (4 in.) post to ensure stability. Each post must be installed in a concrete base that is at least 61 cm (24 in.) in diameter and either 91 cm (36 in.) deep, OR, 15 cm (6 in.) below the frost line, whichever is greater.

## Determining the mounting height

The received signal is the vector sum of the direct signal and the reflected signals. The quiescent (no intruder) received signal is greatly influenced by the mid-point reflections. The phase relationship between the direct and reflected signals will slowly change as the sensor antennas are raised from the ground level.

The two signals (direct and reflected) will combine constructively (in phase), or destructively (out of phase), depending on the sensor mounting height and separation distance. Constructive phasing is preferable because of the higher net signal level received.

Destructive phasing should be avoided because the low signal level causes the receiver's automatic gain control (AGC) to operate closer to the top of its range. This will result in a higher nuisance alarm rate when the microwave path loss increases, for example, during rain or snow.

Charts 1 and 2 on page plot the calculated antenna height versus the separation distance relationship for constructive phasing for X-Band (Intelli-WAVE, Microwave Series 14000, and Series 16000) and for K-Band (Microwave Series 24000) respectively. The calculation assumes that the two antennas (transmit and receive) are mounted at the same height above a relatively flat surface. The areas of constructive phasing are located on each nodal line, (i.e., N1, N2, N3, etc.) and below N1.

The following procedure and recommended mounting height table provide a starting point for determining the mounting height for your specific application. Many factors must be taken into account to ensure optimum performance. Therefore, some adjustments to the recommended mounting heights will most likely be required.

## Mounting height procedure

1. Determine the unit separation in accordance with the detection requirements and clearances (see the Intelli-WAVE Application Note #1 - *DO's and DON'Ts: a planning primer*).
2. For the lower pair, select the mounting height of the center of the antenna from Table 1, Recommended mounting heights. Adjust the height to ensure that the operating point is below N1 (see Chart 1 or 2).
3. For an installation where both X-Band and K-Band microwave units are being employed, the K-Band (Microwave Series 24000) unit MUST be the lower unit. K-Band microwave sensors have better sensitivity to slow-moving intruders. However, they are more susceptible to nuisance alarms from rain and snow. The closely spaced nodal lines (Chart 2) for K-Band microwaves means that if the K-Band unit is used as the upper unit, it will be very difficult to ensure constructive phasing under all weather conditions.
4. For the upper units, select the mounting height of the center of the antenna from Table 1, Recommended mounting heights. Adjust the height to ensure that the operating point is on a nodal line, and that the received signal strength is at the maximum possible.
5. Ensure that both the transmitter and the receiver of each pair are mounted at the same height.
6. Perform all site maintenance as required.

Table 1 Recommended mounting heights*			
Lower unit	Mounting height	Upper unit	Mounting height
Intelli-WAVE	76 cm (30 in.)	Intelli-WAVE	150 cm (60 in.)
Series 14000	60 cm (24 in.)	Intelli-WAVE	136 cm (54 in.)
Series 16000	60 cm (24 in.)	Series 16000	120 cm (48 in.)
Series 24000	30 cm (12 in.)	Series 16000	90 cm (36 in.)

\* Ensure that the operating point (mounting height versus separation) is on a constructive nodal line, or below N1 (see Charts 1 and 2 on the next page).

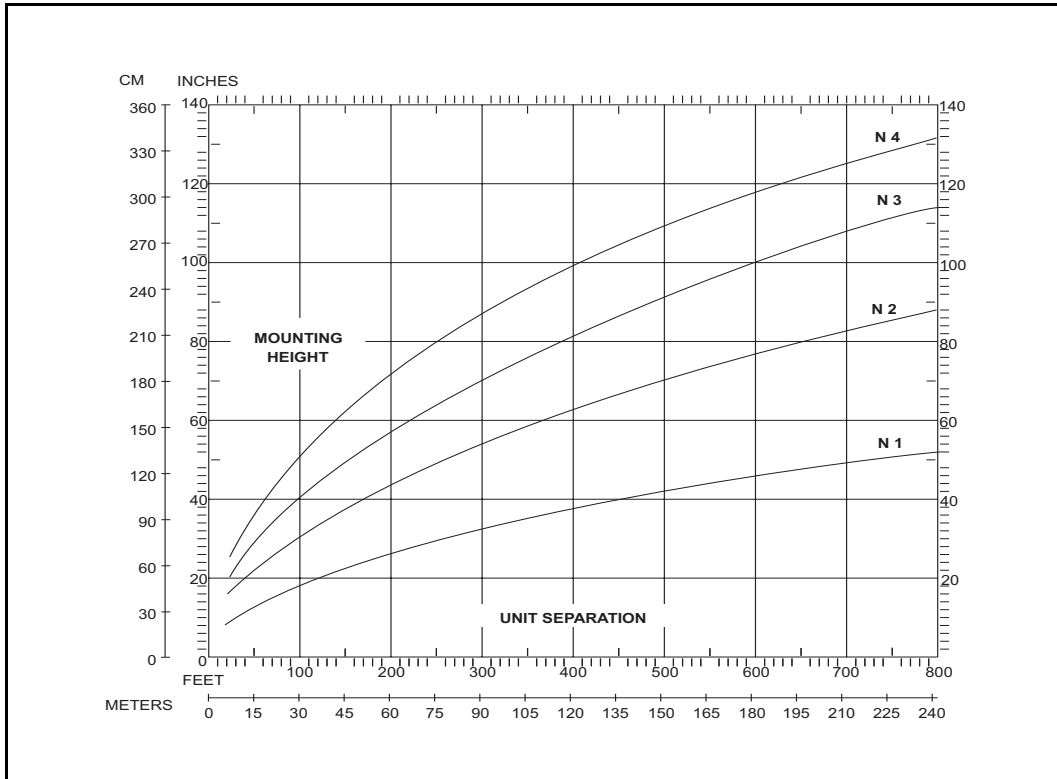

Chart 1: X-band sensor

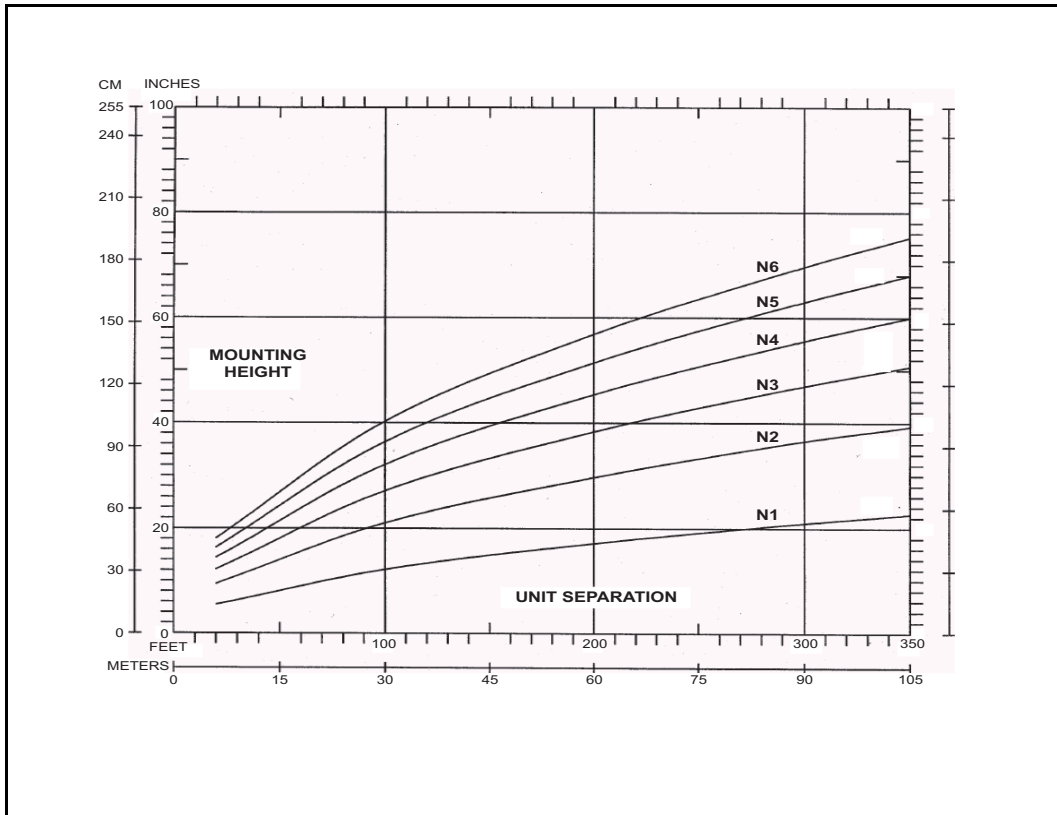

Chart 2: K-band sensor

## Heavy snow areas

Snow accumulation decreases the effective mounting height. This moves the operating point toward destructive phasing, which could result in degraded performance. To compensate for snow accumulation, the setup of the upper unit should be changed as follows:

- Select the height of the upper pair to be at a point of destructive phasing midway between two nodal lines. (As snow accumulates, the effective mounting height will decrease and the operating point will shift toward an area of constructive phasing).
- Check the signal strength of the upper unit according to the product manual. If the signal strength meets the specification for proper operation, do NOT adjust the mounting height. If the signal strength is below the specification, reduce the mounting height in small increments, until the signal strength meets the minimum specification.
- Ensure that both units of each pair are in a correct line-of-sight adjustment.

## Advantages of microwave stacking

- increased zone height
- increased Probability of Detection (PD) (There is double coverage from the two pairs for most of the zone.)
- With an X-Band, K-Band combination, the lower K-Band unit is more sensitive to slow-moving, and crawling intruders. The upper X-Band unit is more sensitive to faster, upright intruders. This combination provides increased detection against both types of intruders

## Disadvantages of microwave stacking

- The cost is almost doubled
- The probability of nuisance alarms is increased
- If the lower unit is a K-Band microwave, there may be an increase of nuisance alarms from rain and snow
- There is a greater potential for interference between microwave pairs
- Because the upper unit is so high above the ground, its operating characteristics (received signal) can change from constructive phasing (strong received signal) to destructive phasing (weak or no received signal) with a slight change in mounting height (Although the mounting height is optimized during installation, snow accumulation changes the effective mounting height. Therefore, during a snowstorm as the snow accumulates on the ground, the operation of the upper microwave pair can become unreliable. Some measures can be taken during installation to anticipate this effect. However, sufficient snow accumulation will severely affect performance.)

## Conclusion

For most installations, the mounting height and detection coverage of Intelli-WAVE will provide sufficient protection against bridging attempts, as long as the recommendations for zone coverage overlap are followed correctly.

When the stacking of bistatic microwave sensors is required, Senstar-Stellar recommends the use of two Intelli-WAVE (MPS 4100) X-Band units:

- Intelli-WAVE is easily field-configured
- Intelli-WAVE antenna elements are field-rotatable
- Intelli-WAVE will have fewer nuisance alarms from weather effects than an X-Band, K-Band combination

## Senstar Stellar

Senstar-Stellar Corporation  
119 John Cavanaugh Drive  
Carp, Ontario  
Canada K0A 1L0

Telephone: +1 (613) 839-5572  
Fax: +1 (613) 839-5830

Website: [www.senstarstellar.com](http://www.senstarstellar.com)

Senstar-Stellar, Inc.  
43184 Osgood Road  
Fremont, CA  
USA 94539

Telephone: +1 (510) 440-1000  
1-800-676-3300  
Fax: +1 (510) 440-8686

email: [info@senstarstellar.com](mailto:info@senstarstellar.com)

Senstar-Stellar Limited  
Orchard House  
Evesham Road  
Broadway, Worcs.

U.K. WR12 7HU  
Telephone: +44 (1386) 834433  
Fax: +44 (01386) 834477

Senstar GmbH  
Riedheimer Str. 8  
88677 Markdorf  
Germany

Telephone: +49 (7544) 95910  
Fax: +49 (7544) 959129

Senstar-Stellar Latin America  
Pradera No. 214  
Col. Pradera  
Cuernavaca, Morelos

62170, Mexico  
Telephone: +52 (777) 313-0288  
Fax: +52 (777) 317-0364