

Transmitter Certification

Test Report

FCC ID: SDB520X

**FCC Rule Part: CFR 47 Part 24 Subpart D, Part 90 Subpart I, Part 101
Subpart C**

ACS Report Number: 06-0147

Applicant: Advanced Metering Data Systems, LLC
Equipment Type: Water Meter Data Transmitter
Trade Name: Flexnet
Model(s): 510, 520

Installation Guide(s)



FIXNET

Model 510 Installation Instructions

Definitions



1



2



3

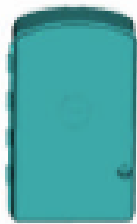

4



5

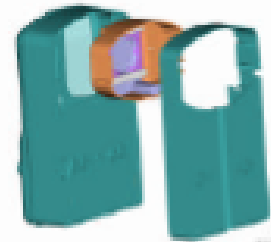

6

- | |
|---|
| <p>1 – Sensus TouchPad
2 – TouchPad Cover
3 – TouchPad Cover, Timmerman Type Fastener, TouchPad Locking Clip
4 – Model 510 Radio (Front View)
5 – Model 510 Radio (Rear View with knockout)
6 – Model 510 Radio and TouchCoupler Spacer with TouchPad Cover</p> |
|---|

Table of Contents

<i>Single Port – TouchCoupler Installation</i>	<u>4</u>
<i>Dual Port – TouchCoupler Installation</i>	<u>5</u>
<i>Single and Dual Port – Wired Installation</i>	<u>6</u>
<i>Activate Radio</i>	<u>7</u>
<i>Appendix A:</i>	<u>9</u>
<i>Appendix B: Regulatory Information</i>	<u>12</u>

Single Port – TouchCoupler Installation

- 1) While Model 510 Radio and TouchCoupler Spacer with TouchPad Cover all still assembled, align the TouchPad Cover over the Sensus TouchPad that is secured to the wall and press on whole assembly.
- 2) For additional support, open Model 510 Radio door and screw two screws using the holes located above the battery compartment.
- 3) Once secured, activate unit (see activation section).

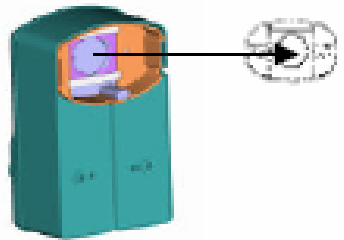

Dual Port – TouchCoupler Installation

1. First choose which Sensus TouchPad will be covered remotely. Place the remote the TouchPad Cover over the Sensus TouchPad.

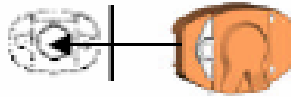

2. While Model 510 Radio and TouchCoupler Spacer with TouchPad Cover all still assembled, align the TouchPad Cover over the Sensus TouchPad that is secured to the wall and press on whole assembly.
3. For additional support, open Model 510 Radio door and screw two screws using the holes located above the battery compartment.
4. With the door still open, run the wire from the remote TouchPad Cover through the bottom of the Model 510 Radio and attach to appropriate terminal screws.

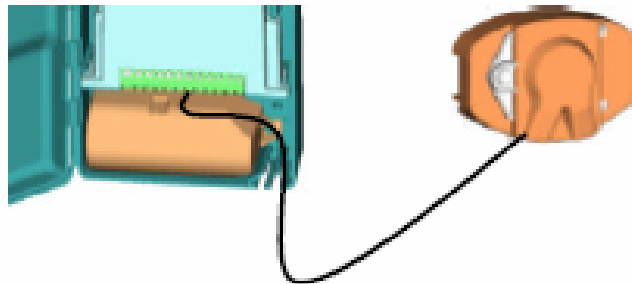

5. Once all connections are complete, activate unit (see activation section).

Single and Dual Port – Wired Installation

1. Open Model 510 Radio door.
2. Secure Model 510 Radio to a wall utilizing the screw holes above the battery compartment.
3. Run the register wires through the bottom of the Model 510 Radio and connect to the appropriate terminals.

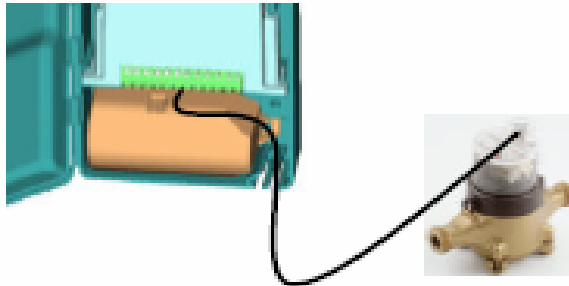

4. Once all registers are connected, activate unit (see activation section).

Activate Radio

Note: if no meters are connected to this radio, the radio will not activate.

- 1.) Once all meters are connected, the radio must be activated in order for it to perform its function. To activate, using a TouchReader or Model 4000 AutoGun, attempt a TouchRead on the Programming/TouchRead port (See picture below). Once TouchRead is activated, the radio will determine what is connected to this unit automatically. This may take up to 3-8 seconds depending on if this unit is dual port capable and what encoders are connected to it.

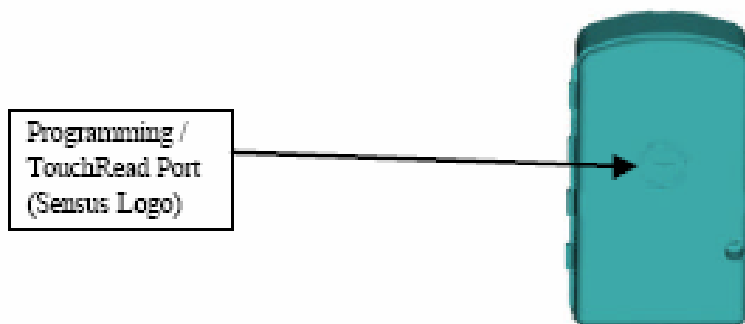

TouchReader

- 2.) The TouchReader will beep once indicating that the radio acknowledged the TouchRead and is now detecting what is connected.
- 3.) After waiting ~3 seconds, attempt another TouchRead, if a read error occurs, the radio is still in detect mode. Repeat this step again in 3 more seconds.
- 4.) If successful detection, it should provide either a TouchRead reading (Sensus only) or a single beep to indicate that the encoder is connected but TouchRead is not supported via the radio
- 5.) If detection is unsuccessful, the TouchRead will beep once and restart the activation similar to step 2 above.

AutoGun

(ID type set to Factory ID – see AutoGun manual for instructions)

- 2.) The AutoGun will beep and display for the ID "MXUGPTC0". This indicates that the radio acknowledged the TouchRead is in mode "0" which is inactive. This will start the detecting process.
- 3.) After waiting ~3 seconds, attempt another TouchRead, if a read error occurs, the radio is still in detect mode. Repeat this step again in 3 more seconds.
- 4.) If successful detection, the AutoGun will display either a TouchRead reading (Sensus only) or

- ID: MXUGPTC1 – which means a TouchRead was attempted on an unsupported meter (Neptune).
 - ID: MXUGPTC2 – which means that the port was configured for a meter type that supports TouchRead (Sensus only) but there was no response from the meter.
- 5.) If unsuccessful detection, the TouchRead will start the activation process again. The ID on the AutoGun will display MXUGPTC0 similar to the step 2 above.

Note: Once the radio is activated and it detected what is connected, the only way to change its configuration as to what is connected is to deactivate the radio using a programming tool and re-activate the radio or use a programming tool to reprogram the port manually.

Warning... Programming a port manually will not allow the unit to perform an automatic detection on that port unless reset to "AutoDetect". The activation process will not reset the port type.

Appendix A:

The following photos show how the PCB is oriented and installed into an enclosure.







APPENDIX B: REGULATORY INFORMATION:

COMPLIANCE INFORMATION:

FCC:

NOTE: This equipment has been tested and found to comply with the limits for a Class B digital device, pursuant to Part 15 of the FCC rules. These limits are designed to provide reasonable protection against harmful interference in a residential installation. This equipment generates, uses, and can radiate radio frequency energy and, if not installed and used in accordance with the instructions, may cause harmful interference to radio communications. However, there is no guarantee that interference will not occur in a particular installation. If this equipment does cause harmful interference to radio or television reception, which can be determined by turning the equipment off and on, the user is encouraged to try to correct the interference by one or more of the following measures:

- Reorient or relocate the receiving antenna.
- Increase the separation between the equipment and receiver.
- Connect the equipment into an outlet or circuit different from that to which the receiver is connected.
- Consult the dealer or an experienced radio/TV technician for help.

WARNING: Changes or modifications to this device not expressly approved by Sensus or AMDS LLC could void the user's authority to operate this equipment.

Industry Canada:

This Class B digital apparatus meets all requirements of the Canadian Interference Causing Equipment Regulations. Operation is subject to the following two conditions: (1) this device may not cause harmful interference, and (2) this device must accept any interference received, including interference that may cause undesired operation.

Cet appareillage numérique de la classe B répond à toutes les exigences de l'interférence canadienne causant des règlements d'équipement. L'opération est sujette aux deux conditions suivantes: (1) ce dispositif peut ne pas causer l'interférence nocive, et (2) ce dispositif doit accepter n'importe quelle interférence reçue, y compris l'interférence qui peut causer l'opération peu désirée.

RF Exposure:

In accordance with FCC requirements of human exposure to radiofrequency fields, the radiating element shall be installed such that a minimum separation distance of 20cm is maintained.



FIXNET

Model 520 Installation Instructions

Definitions

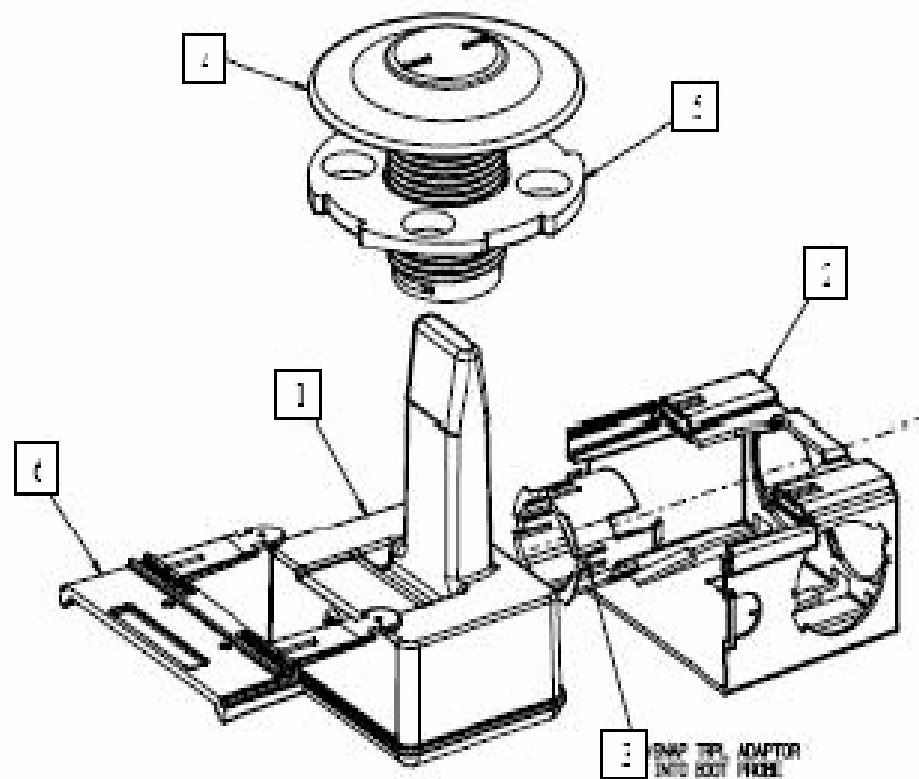

- 1 - HDPE Radio
- 2 - Boot
- 3 - TouchCoupler TR/PL Adaptor (TouchCoupler enabled units only)
- 4 - Pit Lid Housing
- 5 - Pit Locking Nut
- 6 - Boot Locking Clip

Table of Contents

<i>Step 1 Disassemble 520 Unit</i>	<u>4</u>
<i>Step 2 Inserting the Pit Lid Housing</i>	<u>5</u>
<i>Step 3 Securing the Pit Lid Housing to the Pit Lid</i>	<u>6</u>
<i>Step 4 Inserting the Radio Device in the Pit Lid Housing</i>	<u>7</u>
<i>Step 5 Connecting meters to the radio</i>	<u>8</u>
<i>Appendix A:</i>	<u>12</u>
<i>Appendix B: Regulatory Information</i>	<u>14</u>

Step 1 Disassemble 520 Unit

- 1.) Disassemble the model 520 unit to begin the installation procedure. Unlock the radio device by pressing down on the two tabs on the Boot Locking Clip facing the port side connections. Once the tabs are depressed, slide the Boot Locking Clip partially out until the Boot Locking Clip disengages from the Pit Lid Housing.
- 2.) Slide out the HDPE Radio and Boot from the Pit Lid Housing.
- 3.) Remove the Pit Locking Nut from the underneath of the Pit Lid Housing by turning the Nut to the left.

Sample pit lid is shown below:



Step 2 Inserting the Pit Lid Housing

Place the Pit Lid Housing thru the pre-drilled hole in the top of the pit lid.



Pit Lid Housing Inserted Through Pit Lid (Top View)



Pit Lid Housing Inserted Through Pit Lid (Bottom View)

Step 3 Securing the Pit Lid Housing to the Pit Lid

Place the Pit Locking Nut at the bottom of the Pit Lid Housing aligning the Pit Locking Nut with the shaft of the Pit Lid Housing. Tighten the Pit Locking Nut by turning to the right until the unit is firmly secured against the bottom of the pit lid. (See picture below)



Securing the Pit Lid Housing to the Pit Lid

Step 4 Inserting the Radio Device in the Pit Lid Housing

- 1.) Insert the HDPE Radio with Boot into the cavity of the Pit Lid Housing
(See picture below)
- 2.) Align the Boot with the slot located on the bottom of the Pit Lid Housing to secure the unit.
- 3.) To lock the unit into place, push Boot Locking Clip (opposite of the tabs) until tabs are engaged and locked.

The endpoint is then inserted into the Pit Lid Housing:

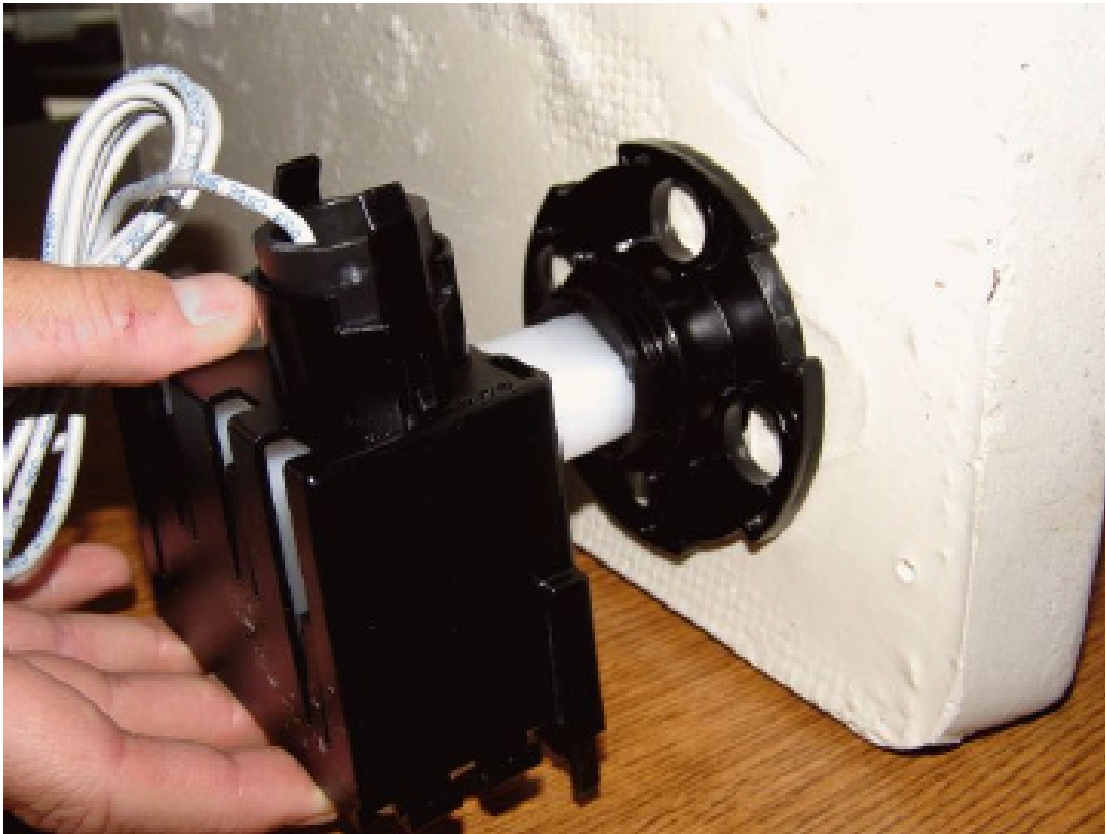

Insertion of the Endpoint into the Pit Lid Housing

Step 5 Connecting meters to the radio

TouchCoupler (Sensus Only)

- 1.) Grasp the TRPL housing and place into Port 1 of the TouchCoupler TR/PL Adaptor until secured. (See picture below)
- 2.) Repeat process into Port 2 if needed.

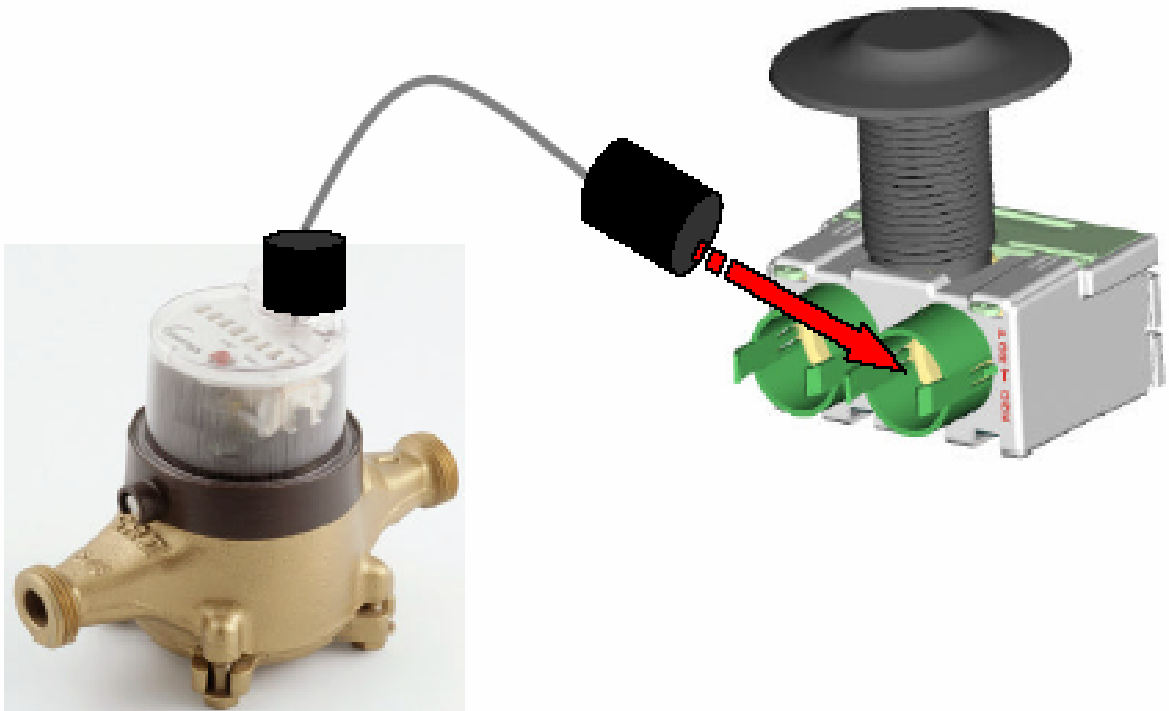

Wired Units (Sensus, MultiRead Module (RadioRead Only), Neptune)

Sensus Encoder

- 1.) Gel cap the red wire from the encoder to the red wire on the reading port (either port 1 or port 2 – if available).
- 2.) Gel cap the green wire from the encoder to the green wire on the reading port.
- 3.) Gel cap the black wire from the encoder to the black wire on the reading port.

MultiRead Module

- 1.) Gel cap encoders to the MultiRead Module per the instructions sheet for the MultiRead Module (AMR-308).
- 2.) Once all encoders are connected to the MultiRead Module, gel cap the red wire from the MultiRead Module to the red wire on the reading port (either port 1 or port 2 – if available).
- 3.) Gel cap the green wire from the MultiRead Module to the green wire on the reading port.
- 4.) Gel cap the black wire from the MultiRead Module to the black wire on the reading port.

Neptune Encoder

- 1.) Gel cap the red wire from the Neptune encoder to the green wire on the reading port (either port 1 or port 2 – if available).
- 2.) Gel cap the green wire from the Neptune encoder to the black wire on the reading port.
- 3.) Gel cap the black wire from the Neptune encoder to the red wire on the reading port.

Step 6 Activate Radio

Note: if no meters are connected to this radio, the radio will not activate.

- 1.) Once all meters are connected, the radio must be activated in order for it to perform its function. To activate, using a TouchReader or Model 4090 AutoGun, attempt a TouchRead on the Programming/TouchRead port (See picture below). Once TouchRead is activated, the radio will determine what is connected to this unit automatically. This may take up to 3-6 seconds depending on if this unit is dual port capable and what encoders are connected to it.

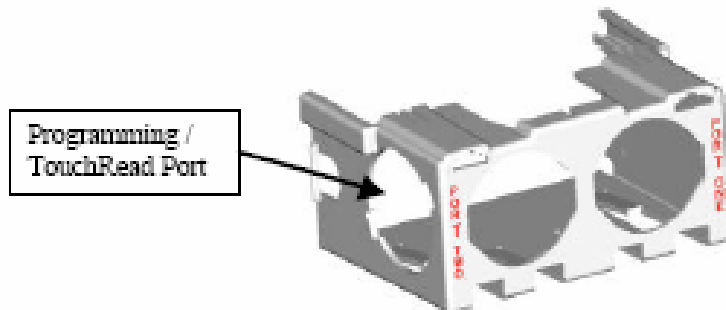

TouchReader

- 2.) The TouchReader will beep once indicating that the radio acknowledged the TouchRead and is now detecting what is connected.
- 3.) After waiting ~3 seconds, attempt another TouchRead, if a read error occurs, the radio is still in detect mode. Repeat this step again in 3 more seconds.
- 4.) If successful detection, it should provide either a TouchRead reading (Sensus only) or a single beep to indicate that the encoder is connected but TouchRead is not supported via the radio.
- 5.) If detection is unsuccessful, the TouchRead will beep once and restart the activation similar to step 2 above.

AutoGun

(ID type set to Factory ID – see AutoGun manual for instructions)

- 2.) The AutoGun will beep and display for the ID “MXUGPTC0”. This indicates that the radio acknowledged the TouchRead is in mode “0” which is inactive. This will start the detecting process.
- 3.) After waiting ~3 seconds, attempt another TouchRead, if a read error occurs, the radio is still in detect mode. Repeat this step again in 3 more seconds.
- 4.) If successful detection, the AutoGun will display either a TouchRead reading (Sensus only) or

- ID: **MXUGPTC1** – which means a TouchRead was attempted on an unsupported meter (Neptune).
 - ID: **MXUGPTC2** – which means that the port was configured for a meter type that supports TouchRead (Sensus only) but there was no response from the meter.
- 5.) If unsuccessful detection, the TouchRead will start the activation process again. The ID on the AutoGun will display **MXUGPTC0** similar to the step 2 above.

Note: Once the radio is activated and it detected what is connected, the only way to change its configuration as to what is connected is to deactivate the radio using a programming tool and re-activate the radio or use a programming tool to reprogram the port manually.

Warning... Programming a port manually will not allow the unit to perform an automatic detection on that port unless reset to “AutoDetect”. The activation process will not reset the port type.

Appendix A:

The following drawings show how the PCB is oriented and installed into an enclosure.

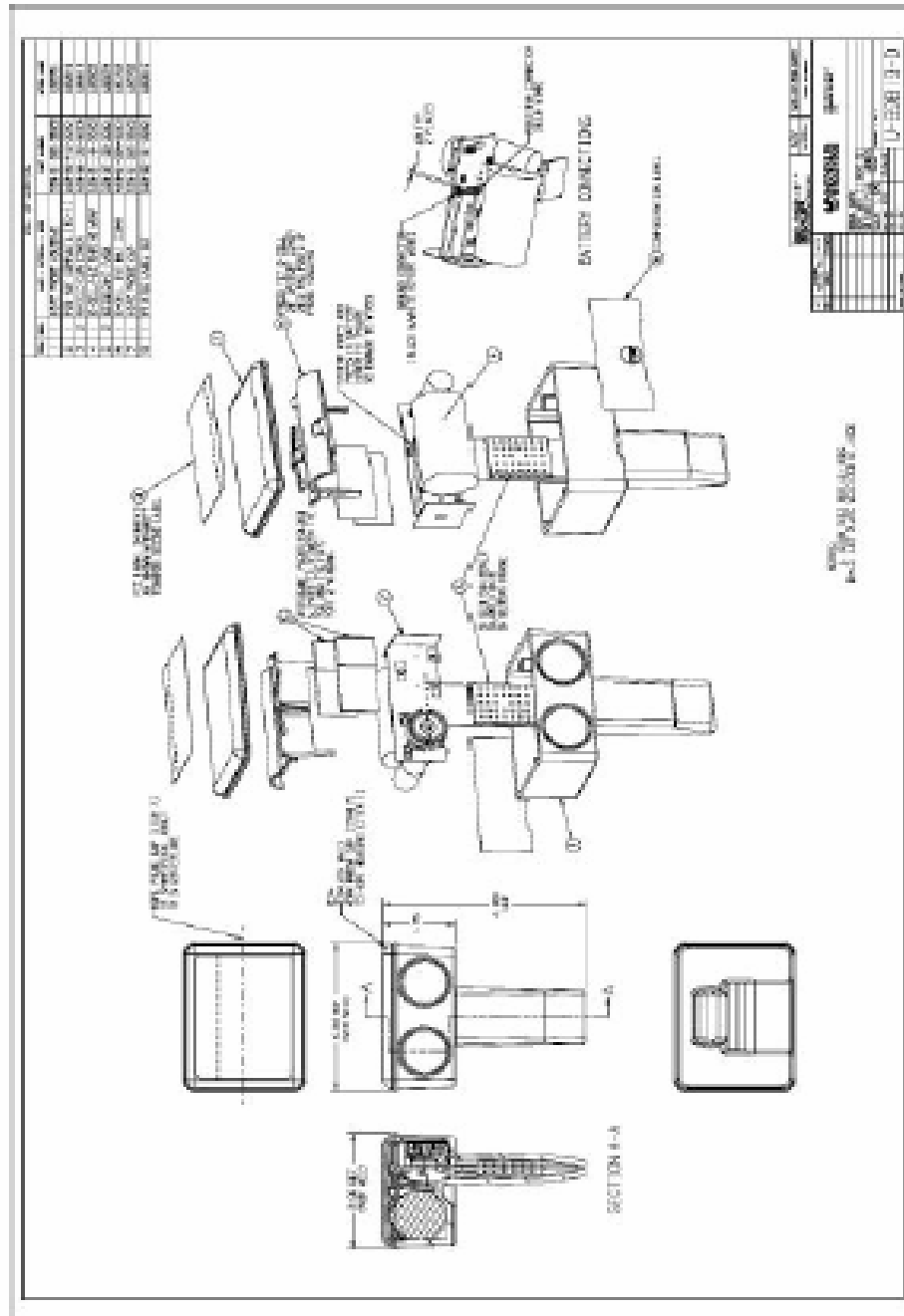

№	№	№	№
1	2	3	4
5	6	7	8
9	10	11	12
13	14	15	16
17	18	19	20
21	22	23	24
25	26	27	28
29	30	31	32
33	34	35	36
37	38	39	40
41	42	43	44
45	46	47	48
49	50	51	52
53	54	55	56
57	58	59	60
61	62	63	64
65	66	67	68
69	70	71	72
73	74	75	76
77	78	79	80
81	82	83	84
85	86	87	88
89	90	91	92
93	94	95	96
97	98	99	100

№	№	№	№
1	2	3	4
5	6	7	8
9	10	11	12
13	14	15	16
17	18	19	20
21	22	23	24
25	26	27	28
29	30	31	32
33	34	35	36
37	38	39	40
41	42	43	44
45	46	47	48
49	50	51	52
53	54	55	56
57	58	59	60
61	62	63	64
65	66	67	68
69	70	71	72
73	74	75	76
77	78	79	80
81	82	83	84
85	86	87	88
89	90	91	92
93	94	95	96
97	98	99	100

1. КОМПОНЕНТЫ НЕ ЗАКРЕПЛЯЮТСЯ НА ПЛАСТИКОВОМ КУЛЬДЕ

APPENDIX B: REGULATORY INFORMATION:

COMPLIANCE INFORMATION:

FCC:

NOTE: This equipment has been tested and found to comply with the limits for a Class B digital device, pursuant to Part 15 of the FCC rules. These limits are designed to provide reasonable protection against harmful interference in a residential installation. This equipment generates, uses, and can radiate radio frequency energy and, if not installed and used in accordance with the instructions, may cause harmful interference to radio communications. However, there is no guarantee that interference will not occur in a particular installation. If this equipment does cause harmful interference to radio or television reception, which can be determined by turning the equipment off and on, the user is encouraged to try to correct the interference by one or more of the following measures:

- Reorient or relocate the receiving antenna.
- Increase the separation between the equipment and receiver.
- Connect the equipment into an outlet or circuit different from that to which the receiver is connected.
- Consult the dealer or an experienced radio/TV technician for help.

WARNING: Changes or modifications to this device not expressly approved by Sensus or AMDS LLC could void the user's authority to operate this equipment.

Industry Canada:

This Class B digital apparatus meets all requirements of the Canadian Interference Causing Equipment Regulations. Operation is subject to the following two conditions: (1) this device may not cause harmful interference, and (2) this device must accept any interference received, including interference that may cause undesired operation.

Cet appareillage numérique de la classe B répond à toutes les exigences de l'interférence canadienne causant des règlements d'équipement. L'opération est sujette aux deux conditions suivantes: (1) ce dispositif peut ne pas causer l'interférence nocive, et (2) ce dispositif doit accepter n'importe quelle interférence reçue, y compris l'interférence qui peut causer l'opération peu désirée.

RF Exposure:

In accordance with FCC requirements of human exposure to radiofrequency fields, the radiating element shall be installed such that a minimum separation distance of 20cm is maintained.