



Quick Start Guide

SC20 series hand-portable radio

sepura

Going further in critical communications

Original Instructions: ENGLISH
Document Number: MOD-15-1898
Issue 1.0

Copyright

© Sepura plc. 2002–2016

All rights reserved. This document is intended for the use of Sepura plc's customers and/or other parties only for the purposes of the agreement or arrangement under which this document is submitted, and no part of it may be reproduced or transmitted in any form or means without the prior written permission of Sepura plc.

Disclaimer

Sepura's policy is to continually improve its products. The features and facilities described in this document were correct at publication, but are subject to change without notice.

Software license agreement

NOTICE: CAREFULLY READ THE LEGAL AGREEMENT CORRESPONDING TO THE LICENSE YOU PURCHASED, WHICH SETS FORTH THE GENERAL TERMS AND CONDITIONS FOR THE USE OF THE LICENSED SOFTWARE.

Contact Details

Sepura plc
9000 Cambridge Research Park
Beach Drive
Waterbeach
Cambridge
CB25 9TL
United Kingdom

sepura.com

CONTENTS

General information	1
Your radio at a glance	2
Battery	4
Charging the battery	4
Fitting the battery	6
Removing the battery	6
Operational overview	7
Keys, buttons and knobs	7
LED indicators	9
Home screen	9
Status icons	10
Antenna and radio coverage	12
Menu	13
SmartMenus	16
Getting Started	17
Power on	17
Power off	17
Locking and unlocking the keypad	17
Adjusting the volume	18
Shortcut Bar	18
Notifications	18
Selecting TMO and DMO	19
Select a talkgroup	20
Emergency operation	21

Making an Alarm call	22
Receiving an Alarm call	22
Clearing an Alarm call	23
Power on Alarm call	23
Contacts	24
Searching and filtering contacts	24
Creating contacts	25
Editing contacts	26
Calls	28
Group calls	28
Individual calls	29
Text entry	31
Character sets	31
Features	33
Connector Protector	33
User profiles	33
Man Down	34
Lone Worker	35
Messages	36
Inbox	36
Create a text message	36
Read a new message	36
Reply to a message	37
Send a message	37
Send a status message	38
Personalising your radio	39

Invert the display	39
Adjusting the backlight	39
Day/Night mode	40
Adjusting text and icon size	41
Setting the display language	42
Tips & Tricks	43

General information

This user guide describes the default operation and features of the SC20 series radio mobile radio. Your service provider or organisation may have customised your radiomobile radioto optimise its performance to suit your individual needs. There may be differences between this guide and the way your product operates. Contact your service provider or organisation for information about the customisation of your SC20 series radio mobile radio.

Safety Information

Before using this product **read the safety and regulatory information** contained in the *Product Safety Guide* (SPR-DOC-00170) supplied with your radio. It is your responsibility to ensure that this product is operated safely at all times, and that local laws governing the use of Radio Frequency (RF) devices are observed.

Sepura products are designed for use by mobile workforces, often working alone, and are intended for use in occupational and controlled conditions. It is recommended that you obtain training on how to operate this product. Your personal safety could be at risk if you do not understand how to operate this product correctly.

Sepura products have been tested to meet strict guidelines for personal safety and operational conditions. Do not operate this product in environments that exceed those listed on the product technical data sheet.

Your radio at a glance

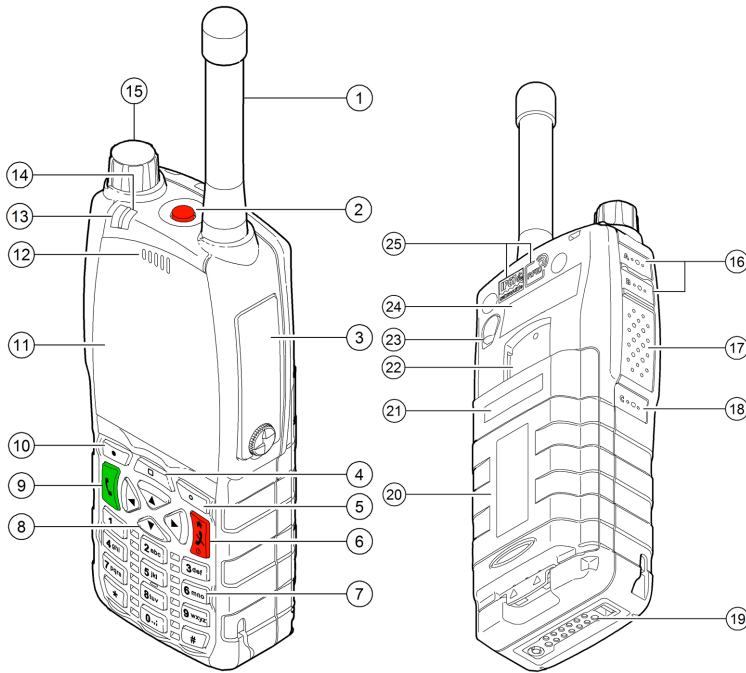

Item	Description
1	Antenna.
2	Programmable Emergency Button. Press and hold (2 seconds) to initiate an Alarm call.
3	Rugged Accessory Connector (sRAC). Provides connection for accessories.
4	Centre context key. Press to activate the feature or option that appears directly above the key.
5	Right context key. Press to activate the feature or option that appears directly above the key.
6	Cancel/Home key. Press and hold (2 seconds) to power on your radio. From the Home screen, press and hold (4 seconds) to power off .

Item	Description
7	Alphanumeric keypad with backlight. Loudspeaker and microphone behind. The loudspeaker is used during Group calls when an audio accessory is not connected and the radio is held in the hand. The microphone is used during phone calls.
8	Navigation keys. Press to scroll through lists and move the cursor when writing text.
9	Select/Send key. Press to initiate a phone call.
10	Left context key. Press to activate the feature or option that appears directly above the key.
11	Colour display with backlight.
12	Earpiece and microphone. Earpiece is active during phone calls when the radio is held like a smart phone against the ear. Speak into the microphone during Group calls when the radio is not attached to an audio accessory and held in the hand.
13	Tri-colour LED (indicator). Indicates various operational states of the radio.
14	Blue LED (indicator). Indicates a missed event such as a call, Callout or message. Also indicates Bluetooth® status.
15	Navi-knob. A continuously rotating knob used to adjust the speaker volume.
16	Side Button (A/B). Press to activate a programmed feature.
17	PTT (Press-to-talk) button. Press and hold to talk during a group call. Release to listen to other radio users.
18	Side Button (C). Press to activate a programmed feature.
19	Digital Accessory Connector (sDAC). Used to charge the battery, program the radio and attach accessories.
20	Battery
21	Battery label area for attaching an asset label (optional).
22	Attachment point for accessory. Used to connect a belt clip or other accessory designed for securing the radio during use.
23	External Antenna Connector used with a car kit to attach an external antenna to the radio.
24	Radio ID Label for attaching an asset label (optional).
25	RFID tag for monitoring and auditing purposes.

Battery

For your safety, inspect the battery regularly for any signs of damage, such as cracks or surface damage caused by an impact or the battery being dropped. Fit a new battery if there are any signs of damage.



Warning: Risk to personal safety. Sepura TETRA radios have been tested and certified using Sepura approved batteries. The use of non-approved batteries may damage the product, will result in non-compliance with regulatory requirements, compromise the product safety ratings including SARS, reduce the length of operating time and will invalidate the product warranty.

Checking the battery charge

Always check the amount of battery charge before lengthy periods of operation. A fully charged battery should provide continuous operation for a full shift, depending on a number of operational factors such as how the radio is operated, the operating environment (temperature and network signal strength) and the condition of the battery. When the radio is powered **on**, the amount of charge remaining may be displayed as a percentage (%) on the screen.

Charging the battery

Your radio is powered by a rechargeable battery. The battery may be recharged many times but it will eventually need replacing to ensure continuous maximum performance from your radio.

First time battery charging

New batteries (Standard battery part no. 300-01174 and High Capacity battery part no. 300-01175) are supplied in 'storage mode' which means they have a minimum amount of charge for storage purposes. Before using a new battery for the first time it must be fully charged to reactivate it. If the battery is used before it is reactivated (fully charged) the radio

may not power **on**, or may indicate a low battery status icon or low level of charge.

Battery chargers

Only use Sepura approved battery chargers. Use of non-approved chargers may not fully charge the battery or damage it. Always read the user documentation supplied with the charger for additional safety instructions and how to use it.

Charging methods

The radio may be powered **on** or **off** during charging.

Attach the Charger cable to the sDAC connector at the base of the radio or place the radio with battery attached into a charging dock. If the battery is charged attached to the radio, and the radio is powered **on**, an indication of the remaining time to fully charge the battery is displayed (in hh:mm format). During charging, the tri-coloured LED on the radio indicates the charging progress and the ⚡ **charging** icon appears on the status line, providing there is sufficient charge in the battery to support this function.

Status LED	Description
Flashing Orange	Battery temperature is either too hot or cold to commence charging.
Solid Orange	Charging in progress.
Solid Green	Charging complete.
Solid Red	Battery has failed to charge and may be not be chargeable. Contact your service provider or Sepura.

The battery may be charged separately from the radio using a battery-only charger.

Fitting the battery

If a belt clip is fitted to the radio, lift the belt clip before attempting to fit the battery. Do not attempt to insert the battery into the battery compartment sideways under the belt clip. This may result in damage to the radio and the belt clip.

To attach the battery, insert the battery into the battery compartment as shown. Press the battery downwards until it clicks into position.

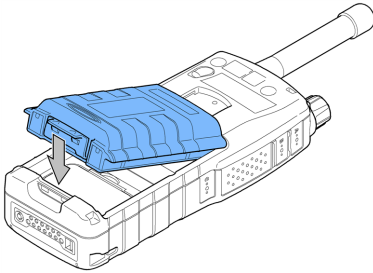

Removing the battery

Always power **off** before removing the battery.

Push the safety latch on the bottom of the battery. Lift the battery upwards and remove.

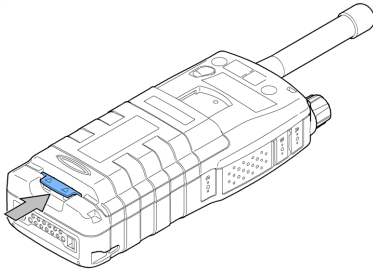

Operational overview

Keys, buttons and knobs

Emergency button

Press and hold (2 seconds) to initiate an Alarm Call.

If the radio is powered **off**, press and hold (3 seconds) to power **on** and initiate an Alarm Call. It may take several seconds for the radio to complete its power on process before initiating the Alarm call.

PTT (press-to-talk) button

Press and hold to transmit (speak) during a Group call.

Release to receive and listen to other radio users.

Cancel/Home key

Press and hold (2 seconds) to power **on**.

In the Home screen, press and hold (4 seconds) to power **off**.

Press and hold (2 seconds) to return to the Home screen from any other screen.

Press to end a phone call.

Select/Send key

Press to initiate a phone call.

Press to select a menu or option.

Navi-knob

Rotate to adjust the volume.

Navigation keys

Press to scroll lists, menus, talkgroup folders and status messages.

Press to move through characters when writing text.

Context keys

Context labels appear at the bottom of the screen, directly above each context key. These labels show the action of the key when it is pressed; either activating a feature or performing a function such as clearing a call (**Clear**) or selecting an option (**Select**).

The labels and actions of the context keys in the Home screen are:

Context key	Label	Action
Left	Menu	Press to enter the main menu.
Centre	Groups	Press to change the talkgroup. See Select a talkgroup on page 20
	Status	Press 2 times to send a status message. See Send a status message on page 38
	Profiles	Press 3 times to select a user profile. See User profiles on page 33
Right	Shortcut	Press to open the Shortcut Bar to quickly access regularly used features or clear a notification. See Notifications on page 18 and Shortcut Bar on page 18

Soft keys

Special features such as SmartMenus can be assigned to a soft key. Your service provider or organisation can provide information about the customisation of your radio's soft keys.

To activate a soft key function, press a programmable side key (A, B, C) or press and hold (1 second) any one of the 0–9, * and # keys.

LED indicators

Blue LED

The blue LED indicates either a missed event, such as a missed call or unread message, or your Bluetooth® status (if enabled). A notification alerting you to the missed call, Callout or unread message appears in the Shortcut Bar. See *Notifications* on page 18.

Tri-colour LED

The tri-colour LED indicates the operational state of the radio.

LED Colour	Description
Solid green	Radio is powering on or in a call and receiving
Solid red	Radio is in a call and transmitting
Intermittent flashing red	Attempting to connect to the network or incoming telephone SDS/Status message or battery low warning
Flashing orange	Incoming telephone call or SDS/Status message
Intermittent four flashes orange	Transmit Inhibit mode or Fallback mode are active

Home screen

The top level screen, known as the *Home screen*, appears when the radio powers **on** and when it is idle.

Tip: To quickly get back to the Home Screen, press and hold (2 seconds) the **Cancel/Home** key.

The *status line*, at the top of the screen, displays various icons to indicate the state of operation or when certain functions like keypad lock have been activated.

The *context key labels* at the bottom of the screen indicate what the context key directly below the label is configured to do. These labels change according to where you are in the menu hierarchy.

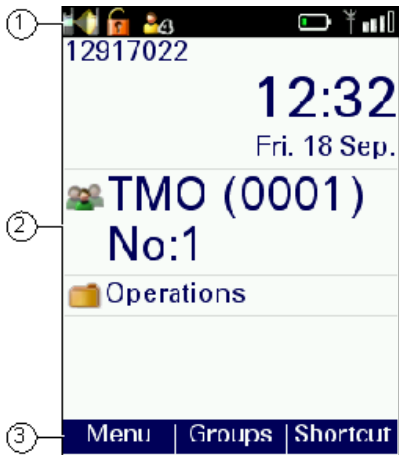

















#	Description
1	Status line showing the radio coverage signal strength, battery charge indicators, and operational status icons.
2	Information area containing information that only appears on the Home screen. This is customised by your service provider or organisation. It may show your selected talkgroup, date and time.
3	Context key options (available in the Home screen).

Status icons

Icons appear on the status line (at the top of the screen) when the radio is engaged in certain activities or when certain functions are active.

Icon	Description
Security and Emergency	
	Emergency Appears when emergency operation mode is active on your radio and an Alarm call is in progress.
	Air Interface Encryption disabled Calls will not be encrypted.

Icon	Description
	E2E Encryption enabled The Secure Communications icon indicates that the selected talkgroup is customised for End-to-End Encryption. In other words, calls you make by pressing the PTT button are End-to-End Encrypted.
	E2E Encryption disabled Indicates that the call is not encrypted.
Trunked Mode Operation (TMO)	
	Outgoing TMO call in progress You are in a call that you initiated.
	Incoming TMO call in progress You are in a call that was initiated by another person or your dispatcher on the TMO network.
	Missed incoming TMO call The blue LED flashes to notify you that you have missed an incoming TMO call. A notification alerting you to the missed call appears in the Shortcut Bar.
	Broadcast Call A high-priority group call (<i>point-to-multi-point</i>) initiated by your Dispatcher to all network radio users. You cannot reply to the caller.
Direct Mode Operation (DMO)	
	Incoming DMO call You are in a DMO call that was initiated by another radio user.
	Outgoing DMO call in progress You are in a call to another radio user.
	Missed incoming DMO Call The blue LED flashes to notify you that you have missed an incoming DMO call. A notification alerting you to the missed call appears in the Shortcut Bar.
General icons	

Icon	Description
	Signal Strength Shows the current signal strength. More bars indicate a stronger signal.
	Good radio coverage Indicates good radio coverage.
	No service Indicates poor signal or no radio coverage.
	Battery Strength Indicates the level of charge in your battery. More bars indicates more charge.
	Low battery warning Appears when there is less than 12% charge remaining in the battery.
	Charging Appears when the battery is attached to the radio during charging and the radio is powered on.
	Keypad locked
	Transmit Inhibit Indicates that you have activated transmit inhibit and the radio is unable to transmit (overridden when Emergency mode is activated).

Antenna and radio coverage

Caution: The antenna must be attached to the radio at all times. Never remove the antenna during operational periods.

The ability to transmit and receive RF signals depends on the strength and quality of the radio coverage.

Good radio coverage is indicated by the Signal Strength icon  and bar indicator displayed on the status line. In Trunked Mode Operation (TMO) the bar indicator represents the network signal strength. In Direct Mode Operation (DMO) it indicates the strength of the signal from the

transmitting radio. Poor or no radio coverage is indicated by a short bar or no bar at all with the  poor signal strength icon.





Menu





Your radio is customised by your service provider or organisation with a number of features that are accessed from the main menu.

- ▶ To open the main menu, in the Home screen press **Menu**.
- ▶ To open a sub-menu or menu option, scroll to the option (highlight it) and press **Select**.
- ▶ To return to a higher level menu, press **Back**.
- ▶ To return to the Home screen at any time within the menu hierarchy, press and hold (2 seconds) the **Cancel/Home** key.

Menu options

The following icons are used to identify the sub-menus that provide access to further options.

Icon	Menu option
	Phone Add, edit and delete your personal contacts within your personal folder. Search (or filter) your contacts to locate the contact you want and initiate a call. Review you call history.
	Messages Read, create, save and send text (SDS) messages. View picture messages (if customised). Select and send a status message. Clear your mailbox of unwanted messages.
	Groups Search your talkgroup folders and select a talkgroup. Enable scanning of your selected talkgroups. Set up your speech call settings.
	GPS Manage your GPS location and position settings. View your current location, direction and speed.

	<p>Applications</p> <p>Your radio may be customised with a number of applications such as Man-down and Lone Worker. Your service provider or organisation may have installed specific applications (Short Data Applications) to help you in your role. Access WAP sites.</p>
	<p>Networks</p> <p>Manage your network connections and DMO options. Change your operating mode (TMO/DMO). Enable/disable Transmit Inhibit mode when working in RF sensitive areas.</p>
	<p>Options</p> <p>Manage your Bluetooth® devices and settings. Personalise your radio settings such as backlight, text size and language. Enable Connector Protector when working in salt laden environments to protect your radio.</p>
	<p>User Profiles</p> <p>Select customised profiles designed specifically for the way you work.</p>
	<p>Help</p> <p>View help, such as a list of customised soft keys on your radio.</p>

Menu Structure

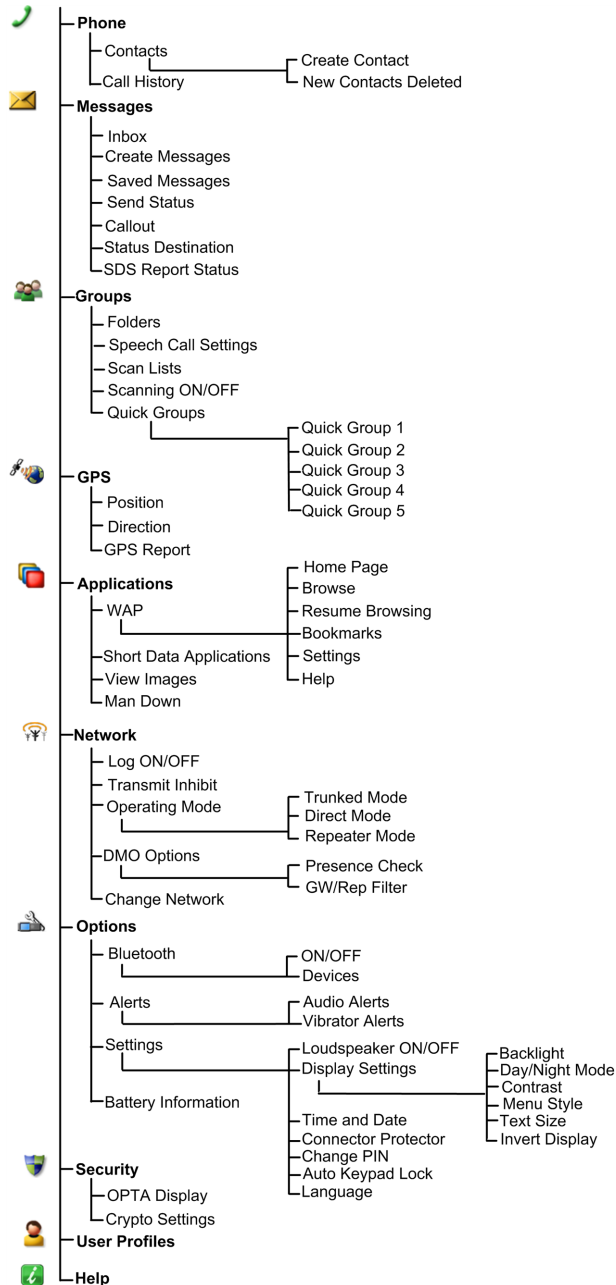

SmartMenus

SmartMenus are designed to provide quick access to regularly used radio features, usually with a common theme. Your service provider or organisation may customise your radio with a number of SmartMenus, for example you may have a SmartMenu containing all your Quick Status messages, another for user profiles and another for selecting operational modes such as toggling on/off covert mode, Transmit Inhibit, loudspeaker mute and so on.

SmartMenus are assigned to a soft key, either a Side key or one of the keys on the keypad. To open a SmartMenu, press the Side key or press and hold (1 second) the assigned key on the keypad.

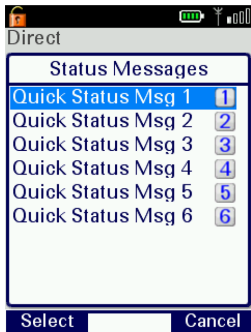

Use the navigation keys to scroll the list of options on the SmartMenu. Options are labelled with a number, shown to the right of the option. To select the option, press the key that corresponds to the number of the option, for example to select option 3, press the 3 key. Note that using this method only options numbered 1 to 12 can be selected using the keys on the keypad (press 0 for option 10, the Star (*) key for option 11 and the Hash (#) key for option 12). For options numbered 13 onwards, scroll to the option (highlight it), and press **Select**.

Getting Started

Power on

To power **on**, press and hold (2 seconds) the **Cancel/Home** key.

Your radio attaches to the last selected talkgroup when it was powered off (if it is 'in service').

Power off

Note: Do not power **off** the radio by removing the battery. The radio must be powered **off** correctly to ensure that it performs a controlled 'powered down'.

To power **off**, from the Home screen press and hold (4 seconds) the **Cancel/Home** key.

Scroll to the **Shutdown** option, then press the **Select** key to power **off** your radio.

Locking and unlocking the keypad

To prevent accidental activity during operation, you can lock the keypad. This will also prevent access to the radio's functions if the radio is stolen. When the keypad is locked, the  Key icon appears in the status line.

The **Navi-knob**, and the **PTT** and **Emergency** buttons remain unlocked so you can still adjust the volume, make a Group or Alarm call when the keypad is locked.

To lock/unlock the keypad:

Press the * (star) key (or a designated soft key), then press the **OK** context key to lock/unlock the keypad.

If you press any other key while the keypad is locked no action is taken. A message is displayed to remind you that the keypad is locked.

Adjusting the volume

Rotate the **Navi-knob** to adjust the volume. A vertical volume meter displays to indicate the current volume level. The radio sounds an audible tone at the new volume level.

Shortcut Bar

You can easily access commonly used radio features such as your **Inbox**, and turn features on and off using the *Shortcut Bar*. The *Shortcut Bar* can contain up to 5 radio features and some of these can be paired with notifications to alert you to a missed call or a new message in your **Inbox**.

To open the *Shortcut Bar*, in the Home screen press the **Shortcut** context key.

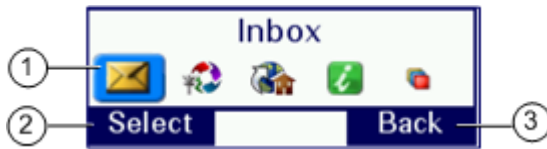

#	Description
1	Use the navigation keys to scroll through the notifications and features. Notifications always appear to the left of features. Press the Right navigation key to continue scrolling right to view more shortcuts (if available).
2	To open a notification or feature, highlight it and press the Select context key.
3	Press the Back context key to close the <i>Shortcut Bar</i> without opening a feature.

Notifications 📢

Like a smart phone, your radio can display notifications to indicate a missed call or new message. They also appear when certain functions are enabled such as mute, transmit inhibit, and Lone Worker.

Some features can be paired with notifications, such as your **Inbox** so when a message is received a notification appears in the *Shortcut Bar* to

alert you to the unread message. When paired with a feature, the feature icon appears with a notification badge ❶.

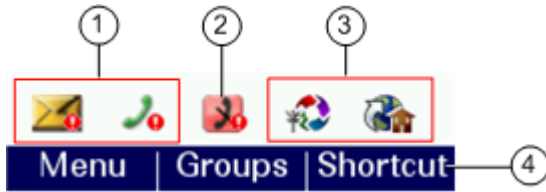

#	Description
1	Notifications paired with features appear to the left of all other feature icons.
2	Example notification of a change of state (Transmit Inhibit).
3	Shortcuts to commonly used features always appear to the right of notifications. Scroll right to see more features (if any).
4	In the Home screen, press the Shortcut context key to access the notification.

To close a notification:

From the Home screen, press the **Shortcut** context key, highlight the notification then press the **Select** context key. Use the feature in the usual way, for example, read an unread message or respond to a missed call. The notification automatically closes and disappears from the Shortcut Bar.

Selecting TMO and DMO

In Direct Mode Operation (DMO), radios communicate directly with other TETRA radios without using a network. Coverage depends on the position of the caller and the receiving radio. When you switch to DMO mode your radio leaves the network and tunes to the selected DMO talkgroup. In Trunked Mode Operation (TMO) your radio operates on the network infrastructure supplied by your service provider.

To change operating mode from the Home screen:

Press the **Menu** context key, then select **Networks > Operating Mode**. Scroll to the mode (highlight it) and press **Select**.

Select a talkgroup

Your radio is customised with talkgroups that typically include users who are either performing a similar role or who are within a distinct location or provide a service that you use.

To select a talkgroup:

1. From the Home Screen, press the **Groups** context key. The current selected folder and talkgroup appear in a selection box.



2. Use the **Left and Right** navigation keys to move between folders at the same level. Use the **Up and Down** navigation keys to move between the folder levels (sub-folders).



Rotate the **Navi-knob** to scroll through the talkgroups within the currently selected folder. The directional arrows under the talkgroup name indicate the rotational direction of the **Navi-knob**.

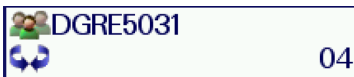

3. Press the **Select** context key to attach to the talkgroup.

Emergency operation

The red button on the top of your radio is programmed to initiate an Alarm call at any time when your radio is in operation. This button is known as the *Emergency Button*.

Your radio may be customised to perform one or more of the following:

- ▶ Initiate an Alarm call set up to one or more pre-defined users (typically to your dispatcher and other members of your talkgroup) and/or;
- ▶ Send an Emergency Status message to an individual, the dispatcher or a talkgroup and/or;
- ▶ Send a position report (GPS dependent).

If you are working in RF sensitive areas and have enabled Transmit Inhibit, prohibiting radio transmission, initiating an Alarm call will override the Transmit Inhibit feature and the Alarm call will be transmitted.

Your service provider or organisation can provide information on how your radio is customised for Alarm calls and how to operate your radio in emergency situations. If you are working in a sensitive environment your radio may be customised for Silent Alarm calls where audible and display alerts are disabled, or your radio may be customised for Live Microphone that allows you to call for assistance hands-free without pressing the PTT button.

Live Microphone feature

Your radio may be customised with the Live Microphone feature. This feature allows you to broadcast a call for assistance hands-free for a specified period of time and without having to press the PTT button. The radio automatically cycles between transmit and receive communication during a programmed period of time (seconds). Live Microphone is cancelled when the time expires or by pressing the PTT button.

Making an Alarm call

You can still make an Alarm call if the keypad is locked.

1. Press and hold (2 seconds) the **Emergency** button; a confirmation beep sounds.
2. Release the button and speak into the microphone.

During an Alarm call:

- ▶ the microphone is 'live' for a programmed period (seconds) allowing you to speak hands-free without pressing the PTT button (customisable)
- ▶ the LED illuminates solid red
- ▶ your radio sounds audible tones
- ▶ a large emergency symbol appears on the screen
- ▶ your identity and talkgroup appears on the display of those receiving the Alarm call

Receiving an Alarm call

An Alarm call overrides any existing calls on the talkgroup.

You know you are receiving an Alarm call when:

- ▶ your radio sounds an audible tone
- ▶ the LED flashes red
- ▶ the emergency symbol appears on the screen
- ▶ your radio status changes to *Emergency*

Clearing an Alarm call

You can only clear an Alarm call that you have initiated.

To cancel the Alarm call, press the **Clear** context key.



Warning: Depending on which network is being used, if the TETRA Alarm call is a group call, then although both of the TETRA Alarm call exit functions will clear the TETRA Alarm call on the call originator's radio, it will not remove the alarm from the system. It should also be noted that those radios alerted to the emergency may, depending upon the infrastructure configuration, remain in the TETRA Alarm call condition until the dispatcher clears the call from the system.

When the Alarm call is cancelled, your radio returns to the talkgroup that was selected before the call was initiated.



Power on Alarm call

If your radio is powered **off**, press and hold (3 seconds) the **Emergency** button to power **on** and initiate an Alarm call. Any customised Welcome screen is not displayed during power **on**. If your radio is customised for PIN entry, you will need to enter your PIN before the alarm call is initiated. It may take several seconds for the radio to complete its power **on** process before initiating the Alarm call.

Contacts

Details of regularly used contacts are stored in a phone book. The phone book has a series of folders labelled *Menu*, *Search*, *All* and *Personal*. Your radio may have additional folders containing contacts programmed into your radio during customisation.

The *Personal* folder contains contacts you create (personal contacts). This folder only appears when you create your first personal contact. The *All* folder contains both personal contacts and contacts programmed into your radio.

Each contact can have up to six associated numbers. The icon next to each contact indicates the dial mode, a radio  or to a  telephone, of the first number associated with it.

To open the Phone book, from the Home screen, press the **Menu** context key, then select **Phone > Contacts**.

To open the Phone book, select **Menu > Phone > Contacts**.

Searching and filtering contacts

You can search the entire phone book for contact names and numbers, or filter the contacts within a folder by entering a search string into the *Search Bar* at the top of any folder (except *Menu*):

When the search is complete:

- ▶ the **Search** folder lists folders containing at least one entry containing the search string, and the number of entries in those folders. You can open any of the listed folders.
- ▶ all other folders are filtered to show their matching entries above a dotted line. All non-matching entries are listed below the dotted line.

To search for contacts and numbers within the phone book:

1. Select **Menu > Phone > Contacts**. Navigate to the **Search** folder.
2. Press the **Up** navigation key to open the Search Bar.

3. Enter a search string (see [Text entry on page 31](#)) and press the **Search** context key.
4. When the search is complete, any folder containing a possible match to your search (and the number of possible matches within that folder) appear in the **Search** folder. To open a folder, select it and then press the **Open** context key.
5. To clear the search string, press the **Delete** context key to delete each character in the search string, then press the **Cancel** context key, then the **OK** context key.

To filter contacts within a folder:

1. Open the folder.
2. Press the **Up** navigation key to open the Search Bar.
3. Enter a search string (see [Text entry on page 31](#)), then press the **Filter** context key.
4. Any contact in the folder that is a possible match to your search criteria appears at the top of the contact list. To view the contact's details, select the contact and press the **Open** context key.
5. To clear the search string, press the **Delete** context key to delete each character in the search string, then press the **Cancel** context key, then the **OK** context key.

Creating contacts

To create a contact:

1. Select **Menu > Phone > Contacts**.
2. Navigate to the **Menu** card and select **Create Contact**.
3. Enter the contact name (see [Text entry on page 31](#)) then press the **Save** context key.

4. Select a dial mode for this contact, either TETRA Network (default) or telephone/mobile network.

To change the dial mode, press the **Up** navigation key to select the dial mode line then use the **Left** or **Right** navigation keys to switch dial modes. Press the **Down** navigation key to continue entering the number.

Note: If the message *Wrong number type* appears, change the dial mode or check that the length of the number is between 5 and 8 numbers.

5. Enter the number (see [Text entry on page 31](#)) then press the **Save** context key.
6. To add more phone numbers for the contact select **Add Next Number** and repeat the previous step.

Tip: To add further contact numbers to a saved contact, open the contact and select **Add New Number** at the end of its numbers list.

7. To return to the Personal folder press the **Cancel** context key.

Editing contacts

You can edit (and delete) contacts in the *Personal* folder of the Phone book.

To edit personal contacts:

1. Select **Menu > Phone > Contacts** and then select the **Personal** folder.
2. Navigate to the contact you want to edit, then press **Open**.

To edit the name:

1. Select the name and then press **Edit**.
2. Make changes as required, then press **Save**.

To edit a number:

1. Select the number and then press **Options**. Select **Edit** and press **Select**.
2. Make changes: to add additional digits press the number keys; to delete digits press the **Left** navigation key.
3. After making changes press **Save**.

To delete a contact:

1. Select the contact and press **Open**.
2. Press **Options**.
3. Select **Edit > Delete contact**, then press **Select**.

Calls

The various types of voice and data calls that are supported by your radio, and the acoustic and visual alerts that accompany a call, depend on your radio's customisation.

Group calls

Group (*point-to-multipoint*) calls are calls where you talk to other users within a nominated group of radio users (a talkgroup). In a Group call only one person can talk at any one time (known as *half-duplex* mode).

During Group calls the microphone at the top of your radio is active and all received audio is routed to the loudspeaker.

Making a group call

1. Press and hold the **PTT** button and speak into the top microphone.

The LED changes to solid red to indicate that your radio is transmitting, and an audible tone is heard and your radio status text changes to 'Talk'.

2. When you have finished talking, release the **PTT** button and listen to audio received, through the loudspeaker.

The LED changes to solid green whilst the group call is active and your radio status text changes to 'Group Call'.

Receiving a group call

When a Group call is received, the LED flashes red and your radio status changes to 'Group Call'. The name of the talk group, talk group folder and the caller's ID are displayed. When the LED changes to solid green (after a few seconds) you can respond to the call.

Individual calls

Individual calls (*point-to-point*) are private calls between you and one other person. You can make individual calls in two modes:

- ▶ individual calls (half-duplex mode)—where only one person can talk at a time using the **PTT** button.
- ▶ individual ‘phone’ calls (full-duplex mode)—where both parties can talk simultaneously.

Making individual calls (half-duplex mode)

Calling a contact:

1. Select **Menu > Phone > Contacts** to open the contacts menu.
2. Navigate to a contacts folder (such as the *All* folder) and select your contact. Press the **Open** context key, then choose the phone number.
3. Press the **PTT** button to initiate the call (or press **Options**, select **Dial** then press **Select**).
4. To speak, press the **PTT** button; release the PTT button to listen.
5. To end the call, press the **Clear** context key or the **Cancel/Home** key.

Calling by dialing:

1. From the Home Screen, dial the number of the person you are calling.
2. Press the **PTT** button to initiate the call (or press the **Call** context key).
3. To speak press the **PTT** button; release the PTT button to listen to the other radio users.
4. To end the call, press the **Clear** context key.

Receiving individual calls (half-duplex)

1. Press the **PTT** button to answer the call or the **Clear** context key to reject the call.

Making individual phone calls (full-duplex mode)

Calling a contact:

1. Select **Menu** > **Phone** > **Contacts** to open the contacts menu.
2. Navigate to a contacts folder (such as the *All* folder) and select your contact. Press the **Open** context key, then choose the phone number.
3. To initiate the 'phone' call press the **Dial** context key.
4. To end the call, press the **Clear** context key .

Calling by dialling:

1. From Home Screen, dial the number of the person you are calling.
2. Press **Send** to initiate the call.
3. To end the call, press **Clear**.

Note: If your radio has been customised with a single dial mode for TETRA, PBX and PSTN numbers, the dial mode icon cannot be changed.

Receiving a phone call

When an incoming phone call is received, your radio sounds an audible alert and displays the identity of the caller (if the contact or number is stored in your phone book).

1. Press the **Accept** context key to answer the call. Press the **Reject** context key to reject the call.
2. To end the call, press the **Clear** context key .

Text entry

Writing and editing text on your radio is similar to most smart phones. *Text edit* mode is automatically activated when you select certain functions, such as creating a message or adding a contact to your phone book.

Character sets

You can use character sets to change the style of the text, and to enter numbers and special characters. The character set can be changed as often as required when entering text. The following character sets are supported:

Character set	Description
Auto-capitalisation (Abc)	The first letter is entered in upper-case, with all following characters in lower-case. New sentences start with a capital letter and end with a full stop (.), question mark (?) or exclamation mark (!) followed by one or more spaces.
Upper case (ABC)	All characters are entered in upper-case.
Lower case (abc)	All characters are entered in lower-case.
Numeric (123)	All characters are numbers.
Special characters(!.@)	You can select special characters such as full stops (.), semi-colon (;) and commas (,) by pressing the 0 key. Further special characters # @ ! " £ \$ % & ' () * + - are available on the # key.

The selected character set is indicated on the status line at the top of the display, next to the Battery Charge icon.

To change the character set:

Press the Star (*) key during text entry.

To enter characters:

Press a key repeatedly to highlight a character in its Character Selection Box at the bottom of the screen, then press the **Select** context key (or wait for the character to be auto-inserted).

To delete a character:

To delete the character to the left of the cursor press the **Delete** context key.

To enter special characters:

To insert punctuation (*full stop, comma, or semi-colon*) press zero (0) repeatedly until the symbol is highlighted in the Character Selection Box, then press the **Select** context key (or wait for the character to be auto-inserted).

To insert a *space* press **1** (on the keypad).

To insert symbols press the hash(#) key repeatedly until the symbol is highlighted in the Character Selection Box, then press the **Select** context key (or wait for the character to be auto-inserted).

Features

Your radio can be customised for various advanced features and can have various soft keys assigned to frequently used features.



Connector Protector

When working in salt water environments or in an area with high salt-laden humidity such as sea mist or fog, enabling the Connector Protector feature will protect the Digital Accessory connector (sDAC) from potential corrosive damage when an accessory is not attached.

Note: A cover must be fitted to the Rugged Accessory Connector (RAC) (on the side of the radio) if an accessory is not attached.

To enable Connector Protector:

1. Press **Menu** then select **Options > Settings > Connector Protection**.
2. To toggle protection on/off press the **Toggle** context key. When the **CP Enable** check box is ticked, Connector Protector is enabled, and when the check box is empty it is disabled.

If Connector Protector is enabled () when the radio is powered **off**, it will remain enabled when the radio is next powered **on** unless the radio is in a charger or car kit or if a data accessory is attached when the radio is powered **on**, in which case Connection Protector is disabled () until the radio is removed from the charger, car kit or data accessory. In these circumstances it is not necessary to re-enable Connector Protector.

User profiles 1

User profiles are pre-set combinations of alerts and settings on your radio. They allow you to switch settings easily to match your circumstances or environment. An icon  1 showing the number of the profile selected, appears on the status line or the Shortcut Bar. Up to ten pre-defined user

profiles may be configured for your radio. Example user profiles could be *Normal*, *Lone Worker* and *Covert*.

To change the user profile:

1. From the Home screen, press the **Groups** context key 3 times (**User Profiles**).
2. Use the navigation keys to scroll through the user profiles.
3. Press the **Select** context key to activate the selected user profile.

Man Down

Man Down is a licensed customisable feature which uses motion sensors to detect motion in three dimensions. When your radio is powered on it stores it's current angle of inclination (orientation). If it moves more than a customised angle from the original inclination or is stationary for more than a customised length of time, the radio sounds an alarm and displays a 'Man Down Alarm' message. In other words the radio can detect conditions indicating that you have become incapacitated. If you do not respond to the alert within a customised time period, your radio initiates a Man Down Emergency and takes action depending on its customisation.

To toggle Man Down on/off:

1. Activate Man Down using one of the following methods:
 - ▶ Press a customised soft key to toggle Man Down on. The sensors activated are those set in [Man Down options on the facing page](#).
 - ▶ Select a user profile which uses Man Down (see [User profiles on the previous page](#)). The sensors activated are those customised in the profile.
 - ▶ From the Home screen, press the **Shortcut** context key, then select the Man Down icon.

A message ('Man Down Starting') is displayed and an alert sounds (a succession of beeps).

2. Attach your radio in a comfortable wearing position on your body. When a two second continuous tone finishes the radio's 'normal' wearing position has been recorded. An icon indicates that Man Down is switched on and which sensors are active.

To deactivate Man Down, either select a user profile which does not use Man Down, or press the customised soft key to toggle Man Down off.

Man Down options

1. Press **Menu** then select **Applications > Man Down**.
2. Select the Man Down sensors to use:  **Motion & Tilt** sensors,  **Motion Sensor** only, or  **Tilt Only** sensor.

If you enable Man Down from a User Profile, the Man Down Settings screen updates to reflect the sensors defined as active in the Profile.

Lone Worker



If you are working alone you can use the *Lone Worker* feature to let your dispatcher know that you are safe.

When Lone Worker is enabled your radio periodically sounds an alert which you must acknowledge—usually by pressing a pre-programmed key—otherwise the radio sends an emergency status message to your dispatcher.

To enable Lone Worker, scroll to a user profile which has **Lone Worker** enabled, then press the **Select** context key. See [User profiles](#) on page 33.

To disable Lone Worker mode, repeat the process and but choose a different user profile.

Messages

Your radio supports  *status* messages,  *text* (SDS) messages and  *picture* messages. All message types are available from the **Messages** menu.

Inbox

Incoming messages are displayed in the *Inbox* with the most recently received messages at the top. Unread messages appear in **Bold**. The icon next to the message indicates the type of message received and whether the message is read or unread.

The Inbox can store up to 50 messages. When the Inbox is full, unsaved older messages are automatically deleted when new messages are received. If you want to keep a message, you must save it.

To open your inbox, from the Home screen, press the **Menu** context key, then select **Messages > Inbox**. A shortcut to your Inbox may be available from the Shortcut Bar, see [Shortcut Bar on page 18](#).

Create a text message

To create a text message, from the Home screen, press the **Menu** context key, then select **Messages > Create Message**. Write your message (see [Text entry on page 31](#)).

To send your message, see [Send a message on the facing page](#).

Read a new message

When a message is received your radio vibrates and/or generates an audible alert. A notification appears in the Shortcut Bar, see [Notifications on page 18](#) and the blue LED flashes.

To read a new message, open your Inbox (**Messages > Inbox**). To open the message, select it and press the **Open** context key. To read a long

message use the **Down** navigation key to continue reading, and the **Up** navigation key to return to the top of the message.

When you have finished reading the message, you can choose to reply to the message (see [Reply to a message below](#)), delete it or save it.

- ▶ To delete the message, press the **Options** context key, select the **Delete** option and press the **Select** context key. Select the **Delete Message** option and press the **Select** context key.
- ▶ To save the message, press the **Options** context key, select **Save** and then press the **Select** context key.

Reply to a message

You can only reply to a text message.

To reply to a message, press the **Reply** context key. Write your message and when you have finished entering text, press the **Send** context key. For information on how to send your message, see [Send a message below](#).

Send a message

Your service provider or organisation may customise your radio with a default destination, for example when you reply to a message it is sent to your Supervisor or Dispatcher. Other options allow you to send your message to your current talkgroup or a contact in your phone book or a known contact by dialling their number (ISSI).

To send to your default destination, select **Send to default** and then press **Send**.

To send to your talkgroup, select **Send to group**. The details of your current talkgroup appear. You cannot change the talkgroup. Press the **Send** context key to send your message.

To send to a contact in your phone book, select **Phonebook** then select your contact and the destination number (see [Contacts on page 24](#)). Press **Send** to send your message.

To dial the number of a known contact, select **Dial**. Enter the ISSI (Individual Short Subscriber Identity) for your contact and press the **Send** context key.

Send a status message

Your service provider or organisation may customise your radio with status messages. These are pre-defined short messages that are uniquely identified by a status code. They are used to notify others of your current status.

To send a status message, from the Home screen press the **Groups** context key 2 times. Use the navigation keys to scroll through your status messages. To send the message, press the **Send** context key. See [Send a message on the previous page](#).

Personalising your radio

You can personalise your display settings (such as text size, backlight, inverting the screen and change languages) and create a personal phone book containing your own contacts.

Invert the display

When you are wearing the radio on your shoulder, attached to a belt or to a body vest, you may want to flip the display upside down to make it easier to read. The Invert Display option rotates all screen elements (apart from the Context key labels) by 180 degrees.

To invert the display:

1. Select **Menu > Options > Settings > Display Settings > Invert Display**.
2. Press the **Toggle** context key. When a tick appears in the check box, the display is flipped, and when the check box is empty the display is set to normal.

Note: When the display is inverted, the navigation keys work in opposite to their normal function. Press the **Up** key to scroll *down* and the **Down** key to scroll *up*. The **Right** key to scroll *left* and the **Left** key to scroll *right*.

Adjusting the backlight

When a call or message is received, and when you press any key, the backlight lights up the display and keypad. The length of time the backlight illuminates is set during customisation.

To adjust the backlight:

1. Select **Menu > Options > Settings > Display Settings > Backlight**.
2. Press the **Toggle** context key.

To adjust brightness:

1. Select **Menu > Options > Settings > Display Settings > Day/Night Mode**.
2. Select **Backlight Level**.
3. Rotate the **Navi-knob** to adjust the intensity of the backlight and the keypad illumination on a scale of 1–7 (max.).

Day/Night mode

When a call or message is received, and when you press any key, the backlight lights up the display and keypad. A bright display can be a potential distraction, particularly when driving at night or in poor lighting conditions. Day/Night mode lets you adjust the intensity of the backlight and keypad illumination to suit your working conditions. Night mode reduces the glare from the display, making it ideally suited for when the radio is cradled in a vehicle at night time.

When the preferences for day and night mode have been set, switching between the modes automatically adjusts the backlight and display settings.

To change Day/Night mode settings

1. Select **Menu > Options > Settings > Display Settings > Day/Night Mode**.
2. Scroll to each option (highlight it) to make your adjustments:
 - ▶ **Day Mode**—to toggle between Day Mode and Night Mode press the **Toggle** context key.
 - ▶ **Backlight Enabled**—to toggle the backlight on/off press the **Toggle** context key. When a tick appears in the box, the backlight is on, and when the box is empty, the backlight is off.
 - ▶ **Backlight Level**—to adjust the intensity of the backlight and the keypad illumination on a scale of 1 to 7 rotate the **Navi-knob**.

Adjusting text and icon size

Your radio uses the default size for the text and icons set during customisation, however it also supports a number of different size modes that control how text and icons are displayed. Having the ability to change the text and icon size is useful when the handset is cradled in the car and you want to enlarge the text and icons to make them easier to read from a distance.

Caution: When selecting larger modes, some prompts or icons may not appear on the radio display.

Your radio supports the following modes:

Normal Mode allows the maximum amount of information available to be displayed in a compact character size.

Large Mode displays screen information in a large character size.

Very Large Mode displays the talkgroup number or talkgroup name, as customised, in an extra large size on the Home screen with all other screens in Large mode.

Custom displays the Home screen, menu and WAP browser in predefined text sizes set during customisation. Only the Home screen supports Very Large mode, with other screens set to either Normal or Large mode.

To change text mode:

1. Select **Menu > Options > Settings > Display Settings > Text Size**.
2. Use the **Up and Down** Navigation keys to highlight the mode and then press the **Select** context key.

The radio displays the Home screen, with the text and icons appearing in the chosen mode.

Setting the display language

Your radio operates in the language chosen during customisation and can support two display languages. The display uses the default language if the radio is only customised for a single language, or the currently selected language if two languages are programmed.

To change the language:

1. Select **Menu > Options > Settings > Language**.
2. Scroll to the language option, and then press the **Select** context key.

The Home screen appears and the display shows the selected language.

Tips & Tricks

Home Screen

To quickly get back to the Home Screen, press and hold (2 seconds) the **Cancel/Home** key.

Keypad lock/unlock

To quickly lock/unlock the keypad, press and hold (2 seconds) the * (star) key.

Change talkgroup

From the Home screen, press the **Groups** context key. Use the navigation keys to change the folder, then rotate the **Navi-knob** to select the talkgroup. Press **Select** to attach to the talkgroup.

Send status message

From the Home screen, press **Shortcut** to open the Shortcut Bar. Scroll to the **Quick Status** shortcut and press **Select**. Use the navigation keys to scroll through the messages. Press **Send** then choose a destination for the message. See [Send a message on page 37](#)

Writing text

To change character sets: press the Star (*) key during text entry.

To delete a character to the left of cursor: select **Delete**.

To add punctuation (*full stop, comma, or semi-colon*): press zero (0).

To insert a *space*: press 1 (on the keypad).

To insert symbols: press the hash(#) key repeatedly until the symbol is highlighted in the Character Selection Box, then press **Select** (or wait for the character to be auto-inserted).

Select and cancel functions

To select and cancel functions within the sub-menus, you can press the **Select/Send** key to select a function and the **Cancel/Home** key to cancel a

function.

Automatic scrolling using the navigation keys

To scroll a list quickly, press and hold the **Up** or **Down** navigation key.

Making a phone call

Instead of using the context keys to initiate and end a call, use the **Select/Send** key to make a call and the **Cancel/Home** key to end the call.

View recent calls

To view recent calls, from the Home screen press **Menu > Phone > Call History**.

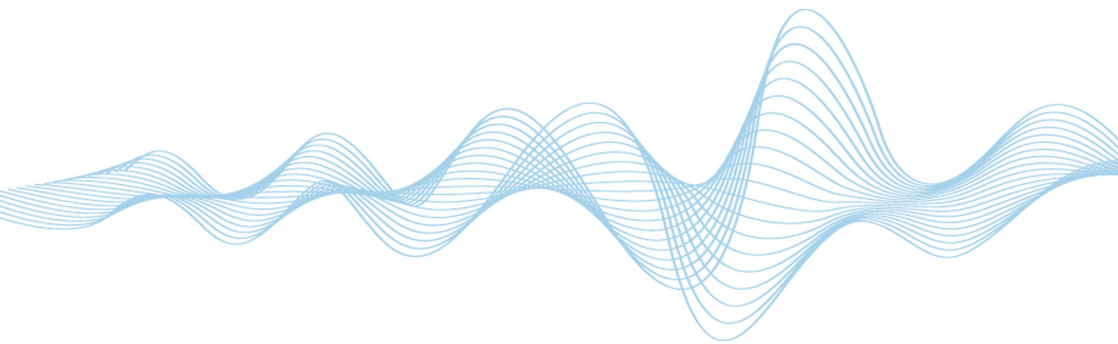

Sepura plc

9000 Cambridge Research Park
Beach Drive
Waterbeach
Cambridge
CB25 9TL
United Kingdom

sepura

[sepura.com](https://www.sepura.com)