

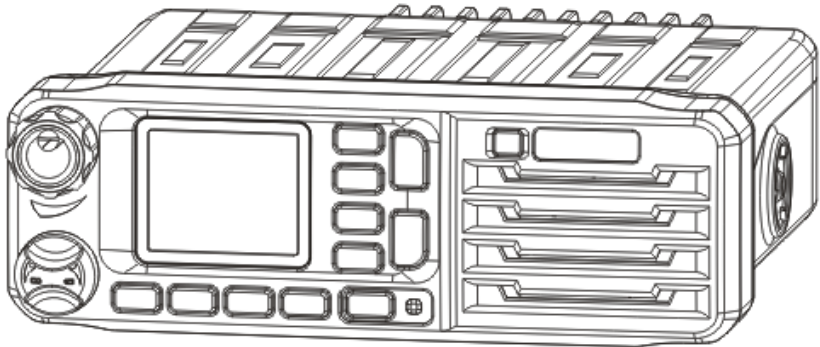

# DMR Mobile

## Vehicle Installation Guide

SEM8040H



This Installation Guide provides basic instructions for installing the DMR mobile transceiver into a vehicle. This product can be installed into various makes and models of vehicles and therefore this is not intended to be a definitive guide to installing the product.

Always read the vehicle manufacturer's handbook before starting to install the product. Installation of this product may affect the vehicle electrical systems. Contact the vehicle manufacturer if you are not certain if it is safe to install this product.

The installation should comply with FCS1362 *CODE OF PRACTICE for the installation of mobile radio and related ancillary equipment in land based vehicles* (see <http://www.fcs.org.uk>).

SPR-DOC-03806/1

Original Instructions: ENGLISH

© Sepura plc. 2014

Sapura's policy is to continually improve its products. The features and facilities described in this document were correct at publication, but are subject to change without notice.

## Unpacking

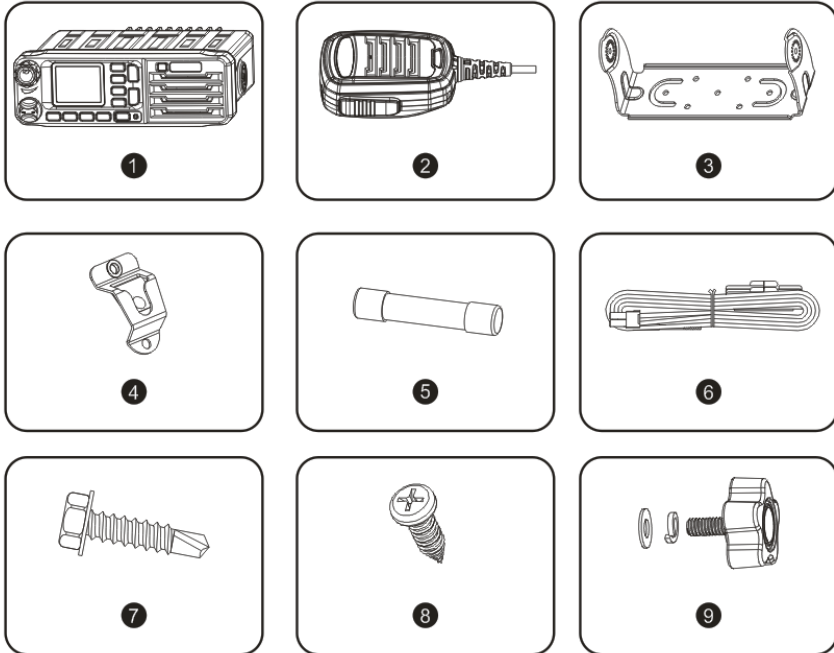

- (1) DMR Mobile
- (2) Fist microphone
- (3) Mounting bracket
- (4) Microphone hanger
- (5) Fuse (spare)
- (6) DC power cable including fuse holder and fuse
- (7) ST4.8x20 self-tapping screw (6 pieces)
- (8) ST4x16 self-tapping screw (2 pieces)
- (9) Knurled knob lock screw (2 pieces)

Unpack the contents of the box and ensure that all items are received in good condition. If any of the goods are damaged or not supplied, notify your Service Provider within 10 days of receipt of equipment.

### Connectors

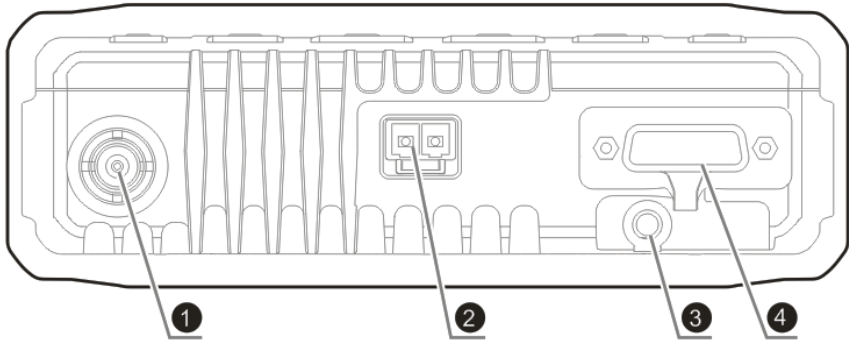

- (1) Antenna connector
- (2) Power cable connector
- (3) GPS antenna connector
- (4) Interface connector

### Safety

This product may affect public broadcast radio, security code alarm systems and some engine management systems.

The installation of this transceiver must be performed by a qualified vehicle installation technician.

This product must be installed in accordance with national and local radio communications authorities and/or Health and Safety regulations.

Always switch off the transceiver in environments where RF wireless devices could potentially cause an explosion. Potentially hazardous areas are not always signed. Obey all signs and instructions relating to the usage of RF wireless devices.

Do not attempt to dismantle this product.

In order to reduce the risk of RF burns, the antenna must always remain connected whilst the equipment is switched on. Under no circumstances should the antenna be connected or disconnected whilst the equipment is switched on. Do not touch the antenna when the transceiver is switched on.

Do not touch the heatsink fins when the transceiver is switched on. There is a potential risk of a burn injury.

If a non-approved accessory is fitted, it may compromise the product safety ratings and may void any product warranty.

It is recommended that the vehicle battery is disconnected before installing the product. Always read the vehicle handbook to establish whether it is practical to

disconnect the vehicle battery without effecting devices, such as central locking mechanisms, engine management computers, security-coded in-car entertainment units and so on.

Prolonged operation of the product when the vehicle engine is switched off could drain the vehicle battery.

Avoid damage to fuel lines, hydraulic lines and existing cables.

This product is suitable for 12V negative earth vehicles only. Do not use other supply systems, this may damage the product.

12V supply leads, antenna cables and speaker wiring must be routed away from gas or fuel lines, and any in-vehicle electrical wiring to reduce the risks associated with a fuel leak.

## **Operator access and safety**

Install the transceiver in a position where the operator has easy access to the controls and the microphone when wearing a seat belt. The controls must be within the operator's normal field of vision.

Position the transceiver so that it does not obstruct or become at risk of damage from any occupant or carried items.

## **Installation Precautions**

### **RF energy**

Vehicle manufacturers make use of electronic control systems such as the ignition and anti-skid devices.

Speed control, fuel injection, anti-lock braking, navigation, air bag and other electronic systems are not adversely effected by RF interference. However, if difficulty is experienced or faulty operation suspected, contact the vehicle manufacturer for advice before continuing to install the product.

To prevent interference with any other electronic systems in the vehicle, the antenna must be mounted away from these devices and their associated cables. Refer to the vehicle handbook for the location of these devices and information relating to radio frequency interference.

### **Specialised vehicles**

The installation on certain specialised vehicles such as fuel tankers and fire-fighting vehicles may be subject to additional safety regulations which must be closely observed. Before starting to install this product, check the relevant safety regulations for the vehicle and you understand them.

### **Petrol powered vehicles**

Check the vehicle to ensure that there are no petrol leaks before starting an installation involving the use of electric tools that may ignite the fuel. Before drilling, always check the location of fuel lines and electrical wiring looms, Avoid drilling near the fuel tank.

## **Vehicle Installation Guide**

### **Gas powered vehicles**

Check the vehicle to ensure that there are no gas leaks before starting an installation involving the use of electric tools that may ignite the fuel.

**DO NOT USE A NAKED FLAME.** Butane and propane gases are heavier than air, and may be present in some lower parts of the vehicle and undetectable by smell. **STOP** if you notice any sign of a gas leak and inform the vehicle owner immediately.

Before drilling, always check the location of fuel lines and electrical wiring looms, Avoid drilling near the fuel tank. Supply cables should be run, if possible, on the opposite side of the vehicle to the gas fuel pipe.

### **Vehicles fitted with electronic devices**

In theory, any vehicle electronic systems could be affected by the presence of radio frequency energy, which when detected may cause the device to malfunction. The source of RF energy may be a mobile transceiver installed within the vehicle or operating in another vehicle in close proximity. If interaction occurs, loss of control could result for the duration of the transmission.

In the interests of safety, the operator must test the vehicle under working conditions on completion of the installation.

## **Installation guidelines and recommendations**

### **Temperature considerations**

Reliable transmit operation is achieved when the transceiver is mounted in a position that allows free flow of air over the finned heat sink. This is achieved by mounting the transceiver in the normal horizontal orientation with no restriction to the air flow. For any other orientation, varying degrees of degradation may result.

Mounting the transceiver on top of the dashboard is not recommended. Exposure to direct sunlight may cause the temperature to rise to over 80°C (176°F). Prolonged exposure to these temperatures may damage the product.

Do not mount the transceiver close to a heat source, for example, in front of the vehicle's heater vent.

### **Location considerations**

The transceiver must be fitted within the interior of the vehicle (excluding the engine compartment) and protected from the external environment and vehicle cleaning operations.

Never install the transceiver directly above the head of the driver or any passenger, or in any position where it could cause harm in the event of an accident.

Ensure that the installation does not impede the normal operation of the vehicle, including the operation of any safety devices such as airbags and seatbelt tensioners.

The transceiver must be installed away from cables carrying very high currents such as the starter motor cable or the electric traction motor and its cables on electric vehicles.

Ensure that the cables are routed so that they are kept well clear of any existing vehicle system cabling.

Secure all cabling to eliminate the possibility of damage by sharp edges or moving parts.

### **Pre-installation checks**

Before installing the product, check that the electronic systems and lights are working on the vehicle.

## **Installing into the vehicle console**

The transceiver can be installed into the vehicle console using the optional Mobile DIN Mount kit (part no. 300-01074).

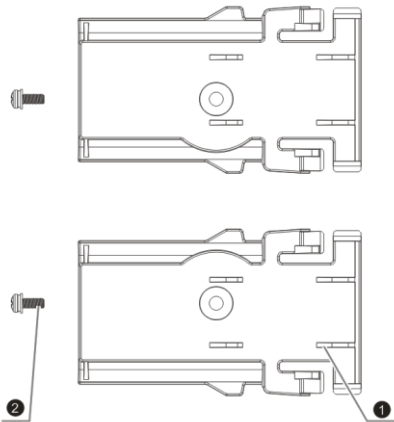

(1) Mounting bracket (2 pieces)

(2) Screws (2 pieces)

Attach the brackets to each side of the transceiver. Note that the brackets are not identical and should be fitted with the flat edge to the top of the transceiver. Secure each bracket into position using a screw.

It may be necessary to connect all cabling before attaching the DIN mount. Slide the transceiver into the DIN mount until an audible 'click' is heard and secure into position.

Only remove the DIN mounted transceiver using specifically designed DIN mount removal tools.

## **Installing using the mounting bracket**

The mounting bracket must be screwed to an appropriate flat surface within the vehicle

Use the bracket as the as a template to correctly position the holes before drilling a pilot hole.

Secure the bracket into position using the six ST4.8x20 self-tapping screw.

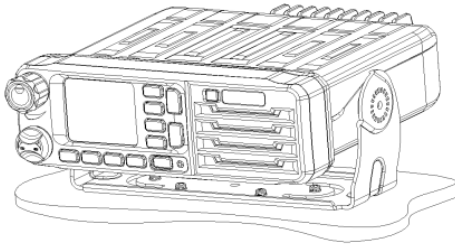
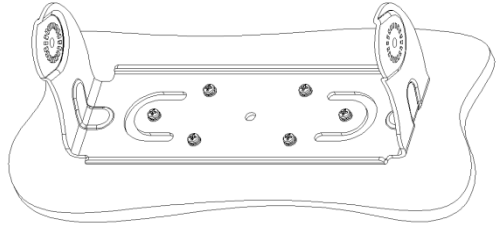

Place the transceiver into the middle of the mounting bracket.

Adjust the transceiver position to a horizontal angle or 20 degrees angle (or angle of depression).

Secure into position using the two knurled knob lock screws.

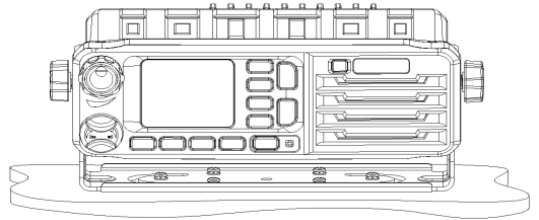



## DC supply connection

With the transceiver end of the power connector resting in its intended final position, route the wires to the vehicle battery.

If the power cable needs to be shortened, it must be shortened from the battery connection end. A fuse must be fitted to the positive line (red wire) when the cable has been shortened. A new fuse holder must be fitted (not supplied) because the existing fuse holder cannot be reused. The fuse must be positioned close to the battery terminal.

---

**CAUTION!** Failure to connect the wires to the correct terminal of the battery or power supply may damage the product and void any warranty.

---

Connect the red wire (+12V) to the positive terminal on the battery.

Connect the black wire (GND) to the negative terminal on the battery.

## Antenna installation

---

**WARNING!** Risk of burn injury. Do not touch the antenna when the transceiver is switched on.

---

### Fitting the DMR mobile antenna

The antenna should be fitted on the centre of the vehicle roof. Alternative positions, such as wing mounting, will give degraded performance. The coaxial feeder should be secured along its length to eliminate the possibility of damage by sharp edges or moving parts.

Refer to the instructions supplied with the antenna for additional safety and installation instructions.

### Fitting the GPS antenna (optional)

The antenna unit connects to a female SMA connector on the rear of the transceiver. It is recommended that the antenna is mounted on the highest point of the vehicle in the centre of the roof with an uninterrupted view of the sky. When a separate DMR mobile antenna is installed, each antenna should be positioned on the centre line of the roof as far away from each other as possible. An active antenna is recommended, the supply of which is on the centre pin, 3.3V nominal, 40mA maximum.

Refer to the instructions supplied with the antenna for additional safety and installation instructions.

### Fist microphone

The fist microphone should be located centrally for the operator(s) to access, using the hanger provided.

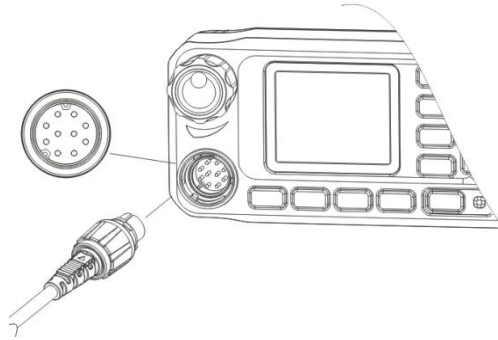

The fist microphone connector has a direction indicator. With the direction indicator facing upwards, rotate the outer self-lock cover in a clockwise direction. Fit the connector to the transceiver ensuring that the self-lock cover fits over the corresponding connector on the transceiver. Pressing firmly, rotate the outer self-lock cover in a clockwise direction until it is secure.

Install the microphone mounting clip in a position that provides the operator with easy access to the microphone and where the cable cannot interfere with the vehicle controls or with the driver's feet. The position must not affect the safety of the driver when driving the vehicle.

Using the two ST4x16 self-tapping screws, secure the microphone hanger at the suitable place inside the vehicle.



Place the fist microphone onto the hanger.

## RF Compatibility Checks

The following checks must always be carried out if the vehicle is equipped with electronic anti-skid, electronic ignition or engine management systems.

The transceiver should be operated only for the time required to make an observation.

An assistant will be required for the following checks.

With the vehicle stationary and the engine running at fast idle, operate the transmitter. Check that the brake lights do not illuminate and that the engine continues to run normally, and that the engine does not surge or cut out.

Operate the brake pedal, key the transmitter and check that the brake lights do not extinguish.

Put the vehicle into motion at a speed of 10 to 15 mph (15 to 25 km/h), key the transceiver and operate the brake pedal simultaneously. Check that the braking action is normal and that the engine does not surge or cut out.

### **WARNING!**

In the event of an apparent malfunction in the braking or any other systems during RF compatibility checks, the transceiver installation should be rendered inoperative and the vehicle manufacturer should be contacted before any further use is made of the transceiver installation.

Unqualified persons should not attempt to modify these units in any way.

## Technical specifications

Dimensions (HxWxD) .....60x177x184mm

Weight..... 1500g

### Fuse

Rating ..... 32V 15A

Type..... SLO-BLO 3AG 1/4" x 1-1/4"

### DC supply

DC supply voltage, nominal ..... 13.6V (10.8V min. 15.6V max.)

Current, max. .... 15A

Ground.....negative

### Environmental

Operating temperature.....-30 to 60°C (-22 to 140°F)

Storage temperature.....-40 to 85°C (-40 to 185°F)

Dust and water rating.....IP54

### Connectors

Antenna .....BNC female

GPS .....SMA female

Sepura plc  
Radio House  
St Andrew's Road  
Cambridge  
CB4 1GR  
UK

Tel: +44 (0)1223 876000

Fax:+44 (0)1223 879000

[Sepura.com](http://Sepura.com)

# **sepura**

---

[Sepura.com](http://Sepura.com)