

# sepura

## Mobile & Gateway Accessory i/f specification

SB-P-06-4066

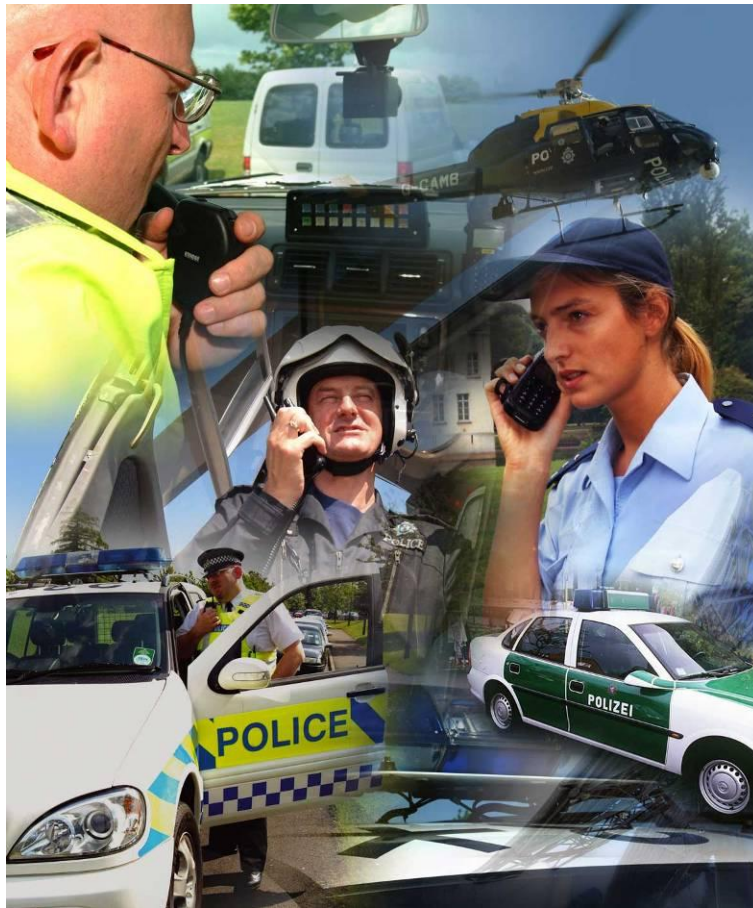

## PRODUCT BULLETIN

© SEPURA PLC 2011

## Contents

<b>LEGAL RESPONSIBILITIES.....</b>	<b>5</b>
<b>ISSUE HISTORY .....</b>	<b>6</b>
<b>PREFACE.....</b>	<b>7</b>
Introduction.....	7
Terminology .....	7
Abbreviations.....	7
Conventions .....	7
<b>DECLARATION OF CONFORMITY .....</b>	<b>8</b>
<b>INTERFACE OVERVIEW .....</b>	<b>10</b>
Transceiver.....	10
Console.....	10
AIU Mk1.....	11
AIU Mk2.....	11
Example interconnect block diagram.....	12
<b>CONSOLE INTERFACE.....</b>	<b>13</b>
Connector details .....	13
Transceiver connector. ....	13
Console/AIU connector .....	13
Signal details.....	14
Line Level Audio Support .....	16
<b>POWER SUPPLY INTERFACE.....</b>	<b>19</b>
Connector details .....	19

Signal details.....	19
Speaker configurations.....	21
<b>AUDIO ACCESSORY INTERFACE (AAI).....</b>	<b>22</b>
Connector details .....	22
Signal details.....	22
Audio Accessory Identity Table .....	24
Accessory Keys Table .....	24
Audio gain .....	25
AIU MK 1 Jack Connectors.....	26
Connector Details .....	26
Jack Signals .....	26
AIU MK 2 Jack Connectors.....	27
AAI2 – via jack connector .....	27
<b>RCI CONNECTIONS .....</b>	<b>29</b>
Connector Details .....	29
Signal details.....	29
<b>DESK MOUNT UNIT CONNECTORS .....</b>	<b>31</b>
Desk Microphone/Headset Connector.....	31
Connector Details .....	31
Signals .....	31
Foot Switch Connector .....	31
Connector Details .....	31
Signals .....	32
Loudspeaker Connector .....	32
<b>DATA CONNECTOR INTERFACE .....</b>	<b>33</b>
Connector details .....	33

---

Signal details.....	33
<b>ANTENNA'S .....</b>	<b>35</b>
Connector details .....	35
Signal details.....	35
<b>GPS ANTENNA.....</b>	<b>36</b>
Connector details .....	36
Signal details.....	36
<b>CONSOLE AND AIU CABLE SPECIFCATION .....</b>	<b>37</b>
Cableform Mechanical Details.....	37
Cable form Grommet.....	38
<b>NOTICE .....</b>	<b>39</b>
Contact Details.....	39

## LEGAL RESPONSIBILITIES

The information in this document is subject to change without notice and describes only the product defined in this document. This document is intended for the use of Sepura plc's customers and/or other parties only for the purposes of the agreement or arrangement under which this document is submitted, and no part of it may be reproduced or transmitted in any form or means without the prior written permission of Sepura plc.

The document has been prepared to be used by professional and properly trained personnel, and the customer and/or other party assumes full responsibility when using it. Sepura plc welcomes customer and/or other party comments as part of the process of continuous development and improvement of the documentation.

The information or statements given in this document concerning the suitability, capacity, or performance of the mentioned hardware or software products cannot be considered binding but shall be defined in the agreement or arrangement made between Sepura Plc and the customer and/or other party.

However, Sepura plc has made all reasonable efforts to ensure that the instructions contained in the document are adequate and free of material errors and omissions. Sepura plc will, if necessary, explain issues which may not be covered by this document.

Sepura plc's liability for any errors in this document is limited to the documentary correction of errors. Sepura plc will not be responsible in any event for errors in this document or for any damages, incidental or consequential, (including monetary losses), that might arise from the use of this document or the information in it.

This document and the product it describes are considered protected by copyright according to the applicable laws.

Other product names mentioned in this document may be trademarks of their respective companies, and they are mentioned for identification purposes only.

## ISSUE HISTORY

Version	Date	Change
Version 1	1 <sup>st</sup> June 2006	Supersedes SB-P-05-4042
Version 2	24 <sup>th</sup> July 2006	Added declaration of conformity statement. Added abbreviations table. Clarified difference between Mk1 and Mk2 AIU's. Added cable form details.
Version 3	22 <sup>nd</sup> Sept 2006	Clarified data interface = PEI port Corrected AIU Mk1 and Mk2 contents re audio accessory support Clarified MIC and EAR on RCI port no longer supported AIU Mk1 superseded by AIU Mk2 Added Input freq spec and levels for GPS antenna
Version 4	19 <sup>th</sup> Jan 2007	3679 parameter details added SRM/G2 and 3 digital I/O capability clarification.
Version 5	17 <sup>th</sup> April 2007	Added reverse battery polarity comment and note re digital input resistance. Corrected block diagram GPS connector. Added GPS LNA gain requirement
Version 6	17 <sup>th</sup> Feb 2009	Incorporates V9 changes (AIS Issue 7 and 8 of the development document)
Version 6a	6 <sup>th</sup> May 2009	Added [ITU-T V.24] and [ITU-T V.28] RS232 serial data compliant
Version 6b	13 <sup>th</sup> Aug 2010	Added comment to section 6 regarding sidetone being present for all accessories
Issue 7	15 <sup>th</sup> Sept 2010	Corrected formatting issues found in issue 6b
Issue 7a	10 <sup>th</sup> Jan 2011	Corrected hyperlink error on page 13 & 14. Added reference for SCC AIS
Issue 7b	20 <sup>th</sup> Jul 2011	Further tidy up of formatting
Issue 7c	30 <sup>th</sup> Jul 2012	Corrected references to digital i/o on console (page10)

## PREFACE

### INTRODUCTION

This product bulletin describes the electrical and physical interfaces of the 2000 and 3000 series of Sepura Mobile and Gateway products.

It has been produced to enable accessory providers to interface their products to these radio platforms.



### TERMINOLOGY

Term	Definition
Signal names with lower case "n".	These signals are active low.

### ABBREVIATIONS

Convention	Description
AAI	Audio Accessory Interfaces
AIU	Application Interface Unit
DMU	Desktop Mount Unit
MDT	Mobile Data Terminal
RCI	Remote Control Interface
RCU	Remote Control Unit
PEI	Peripheral Equipment Interface
PTT	Press-to-talk switch.

### CONVENTIONS

Convention	Description
	Note icon, emphasizes related, reinforcing, or important information.
	Caution icon. Indicates actions or processes that require caution from the user

## DECLARATION OF CONFORMITY

Sepura mobile terminals and approved accessories are compliant with the essential requirements of the 1999/05/EC Radio and Telecommunications Terminal Equipment (R&TTE) Directive. The mobile variants and accessories are specified in the Declaration of Conformity number DC/C 02001-3.

A copy of the declaration is available from Sepura on request.

As such, Sepura mobile terminals are compliant with the following mandatory specifications:

Safety to relevant parts of EN 60950 (Safety of Information Technology Equipment). This includes the Low Voltage Directive (LVD);

Electromagnetic Compatibility (EMC) to relevant parts of EN 301 489 (Electromagnetic Compatibility & Radio Spectrum Matters);

TETRA air interface to EN 303 035 (Terrestrial Trunked Radio (TETRA); Harmonized EN for TETRA equipment covering essential requirements under article 3.2 of the R&TTE Directive);

In addition, Sepura mobile terminals and Third Party Accessory must also maintain conformance in the following areas:

Dust & moisture protection to IP54 or greater to meet the needs of the user environment and the relevant parts of ETS 300-019; CEN1789:2000

Protection against Acoustic Shock to relevant parts of ITU P.360. Sepura mobile terminals comply with the maximum audio levels specified for Longer Duration disturbances.

The performance of the mobile must not be compromised by the r.f. field generated by the mobile interfering with the accessory (different versions of Sepura mobile terminals operate over frequencies within the range 350 MHz to 900 MHz and generate signals complying with TETRA standards).

For example no audio interference should occur when a TETRA portable transmitting at 1 W r.f. power, at frequencies between 300 MHz and 900 MHz, is held within 1cm of the accessory.

The product shall not degrade the performance of a SRM/G 3500/3900 installation when tested to TETRA EMC spec. EN 301489-1&18 V1.6.1 (2005-09) Including Annex B.

The combination of the accessory and the mobile must be "fit for purpose". The use of an accessory must not make the mobile difficult or awkward to use, or in any way degrade its performance.



It is most important that any accessory designed for use with Sepura mobile terminals does not affect any of the current approvals



Sepura requires the designer/manufacturer to:

- Allow Sepura to review, and comment on, the “Test Plan” — this document will describe the tests to be performed by, or on behalf of, the Third Party accessory designer/manufacturer to confirm continued compliance with the above specifications,
- Provide Sepura with a “*technical file*”, which shall contain design details and results of tests undertaken and the appropriate Declaration of Conformity. The information must be approved by Sepura prior to the Third Party supplying the Accessory to customers.
- Sepura must be notified of any amendment to the approved Accessory which could affect the continued conformance. In the event that there is a problem, perceived or real, with the interaction of Sepura mobile terminals and the supplied Third Party Accessory, the Third Party must make available to Sepura documentary evidence of relevant test results.



The “*technical file*” must be approved by Sepura prior to the Third Party supplying the Accessory to customers.

## INTERFACE OVERVIEW

The Mobile and Gateway products are available as a one, two or three unit solution supporting a mix of up to two Consoles or Application Interface Units (AIU) plus the transceiver, allowing the radios to be used in many different applications and support up to 4 audio accessories such as handsets, fist microphones and headsets.

### TRANSCEIVER

The SRM and SRG series of transceivers support:

- 2 off Console Interfaces - each can support a Console, an AIU, or an external data application connected via a Sepura data lead. Any combinations of units on the two Console Interfaces are possible. The Console interface is also used to customise and program the unit via Radio Manager.
- 1 off Power interface providing connection for the battery, ignition sense line and also the transceivers speaker.
- 3 digital inputs and 1 digital output on the power interface connector
- 1 off RF connector for the Tetra antenna.
- GPS connector (optional).



The SRM2000, SRG2000 and SRM3500 series of transceivers are no longer available; they have been superseded by the SRG3500/SRG3900 transceiver.

### CONSOLE

Each Console provides:

- 2 off AAI ports allowing connection of two audio accessories. Each AAI supports optional hook signalling, PTT input and up to 6 accessory keys.
- 1 off data interface with RS232 PEI port allows connection to an external data application via a Sepura Data Lead. The interface is also used to customise and program the unit via Radio Manager.
- The extra 3 digital inputs and 1 digital output available on the transceiver power interface connector are not available from the console.



For details of the SCC accessories interface, see document MOD-10-1253 for further information

### AIU Mk1

The AIU Mk1 provides:

- 2 off AAI ports allow connection of two audio accessories. Each AAI supports optional hook signalling, PTT input and up to 6 accessory keys. AAI2 audio connections are also mirrored to the Jack sockets, allowing flexibility in the connection of audio accessories.
- 1 off data interface with RS232 PEI port allowing connection of an external data application via a Sepura Data Lead. The interface is also used to customise and program the unit via Radio Manager.
- 3 digital inputs.
- 1 digital output.



The AIU Mk1 (part number 300-00087) is no longer available, it has been superseded by the AIU Mk2 (part number 300-00217).

### AIU Mk2.

The AIU Mk2 supersedes the MK1 device and provides:

- 1 off AAI allowing connection of one audio accessory. The AAI1 supports optional hook signalling, PTT input and up to 6 accessory keys.
- AAI2 is only presented on a Jack socket, allowing connection of a second audio accessory.
- 1 off RCI port enabling control of the transceiver via an RCU such as the Sepura 300-00164.
- 1 off data interface with RS232 PEI port allowing connection of an external data application via a Sepura Data Lead. The interface is also used to customise and program the unit via Radio Manager.
- 3 digital inputs.
- 1 digital output.

**EXAMPLE INTERCONNECT BLOCK DIAGRAM**

The diagram shows just one of many possible solutions and highlights the flexibility of the Sepura product.

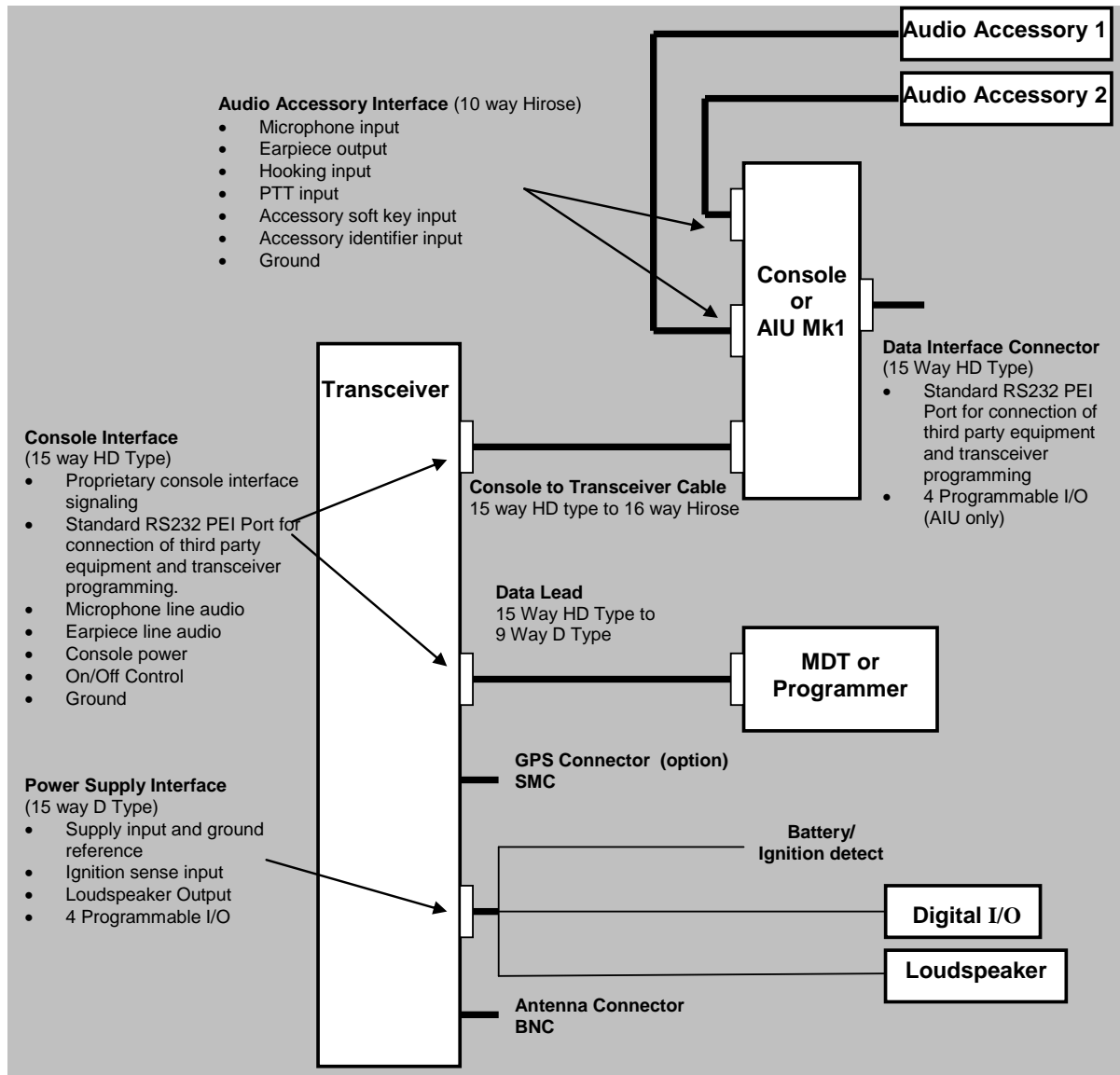

## CONSOLE INTERFACE

There are a number of Console Interfaces:

2 off on the Transceiver designated 'Interface1' and 'Interface 2'.

1 off on the Console used to connect the Console back to the transceiver via 'Interface1' or 'Interface 2'.

1 off on AIU Mk1 and 2 designated 'TRX' used to connect the Console back to the transceiver via 'Interface1' and 'Interface 2'.

### CONNECTOR DETAILS

#### TRANSCEIVER CONNECTOR.

Connector Type: 15 way high density D type female

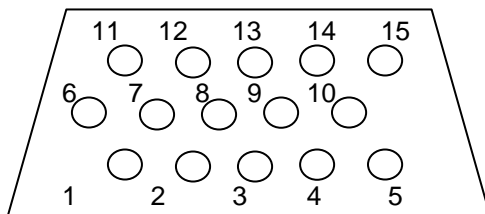

Connector viewed from the rear of the Transceiver

#### CONSOLE/AIU CONNECTOR

Connector Type: Hirose 16 way male header,

Sepura part number 3513 999 99318

Mating plug: Hirose number DF11-16DS-2C

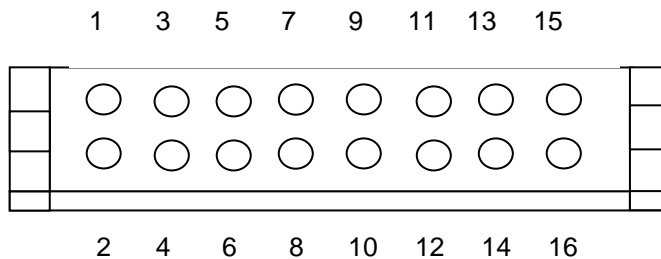

Connector viewed from the rear of the Console.

## SIGNAL DETAILS

Transceiver Pin No. (15 way HD D-type)	Console Pin No. (16 way header)	Signal Name	Signal Direction	Signal Function	Signal Characteristics
1	14	CONSOLE_T XD	<b>Input to</b> control subsystem	Control data from the console.	RS232 levels
2	16	CONSOLE_R XD	<b>Output from</b> control subsystem	Control data to the console.	RS232 levels
3	5	PWR_ON	Output from console subsystem	Switch signal to turn transceiver on <sup>2</sup> .	Low going edge triggered. Pull to 0 V to switch-on. (Pull up to un-switched 12 V rail in the transceiver.) Assertion time: 10 ms
4	15	POWER_OUT	Output from PSU subsystem	Power supply to console	13V nominal supply, enabled internally to the transceiver. Includes over current/temperature protection. Rated for 280 mA nominal load 400 mA max.
5 Console interface 1	2	LS_LINE_1 <sup>3</sup>	Output from audio subsystem	Audio line output to console.	Maximum output (≅peak DAC output) 1.25 V <sub>pk</sub> sine, a.c. coupled, into 600 Ω load.
5 Console interface 2	2	LS_LINE_1 <sup>3</sup>	Output from audio subsystem	Audio line output to console.	Maximum output (≅peak DAC output) 1.25 V <sub>pk</sub> sine, a.c. coupled, into 600 Ω load.
			Line output from audio subsystem.	LINE AUDIO OUT See note 3 below	Maximum output (≅peak DAC output) 1.25 V <sub>pk</sub> sine, a.c. coupled, into 600 Ω load.
6	4	LS_LINE_2	Output from audio subsystem	Ground return for audio line output.	Ground to audio star point
7 Console interface 1	1	MIC_LINE_S IG	Single function: input to audio subsystem.	Audio line input from microphones connected to console.	Maximum operating level (≅ FSD on speech ADC) 0.65 V <sub>pk</sub> sine, AC coupled, into 600 Ω load impedance.
7 Console	1	MIC_LINE_S IG	Reserved input function	Reserved input function	Reserved input function

Transceiver Pin No. (15 way HD D-type)	Console Pin No. (16 way header)	Signal Name	Signal Direction	Signal Function	Signal Characteristics
interface 2			Input to audio subsystem	Microphone input.	Audio in: maximum operating level ( $\cong$ FSD on speech ADC) 0.65 V <sub>pk</sub> sine, AC coupled, into 600 $\Omega$ load impedance.
			Line input to audio subsystem	LINE AUDIO IN See note 3 below	Audio in: maximum operating level ( $\cong$ FSD on speech ADC) 0.65 V <sub>pk</sub> sine, AC coupled, into 600 $\Omega$ load impedance.
8 Console interface 1	3	MIC_LINE_GND	Input to audio subsystem.	Ground return for microphone input.	Main ground to audio star point via 100 $\Omega$ resistor.
8 Console interface 2.	3	MIC_LINE_GND	Input to audio subsystem.	Ground return for microphone input.	Main ground via 100 $\Omega$ resistor. Input voltage must be < 0.3 V (to ensure input functions as microphone input).
			Reserved function	Reserved function	Do NOT tie to ground
9	9	RS232_DCD <sup>4</sup>	Output from control subsystem		RS232 levels
10	7	RS232_RXD <sup>4</sup>	Output from control subsystem		RS232 levels
11	12	RS232_TXD <sup>4</sup>	Input to control subsystem		RS232 levels
12	11	RS232_RTS <sup>4</sup>	Input to control subsystem	Hardware flow control	RS232 levels
13	10	RS232_CTS <sup>4</sup>	Output from control subsystem	Hardware flow control	RS232 levels
14	8	RS232_DTR <sup>4</sup>	Input to control subsystem	Data terminal ready	RS232 levels
15	13	GND	-	Power Ground and return for digital paths.	-
metal shell	6	Screen	-	Over-all cable screen	Connect to digital GND

Notes:  
Intentionally blank

The mechanism to switch the transceiver off from the console uses a Sepura proprietary message sent over the console control data interface (pins 1 and 2).

Line level audio is supported on the 380-430MHz band transceiver with V9 software (or latter) plus the appropriate Feature License Code (part number 600-00033) installed via Radio Manager. 380-430MHz radios can be identified by having “W” as the fifth character of the nineteen character hardware code.

RS232 interface is [ITU-T V.24] & [ITU-T V.28] Compliant

**LINE LEVEL AUDIO SUPPORT**

The following table is a subset of the table in 6.4 showing only the relevant connections for Line Level audio:

Line Level Audio IN (pins 7 and 8 on Console Interface 2) and  
 Line Level Audio OUT (pins 5 and 6 on Console Interface 2)

	Transceiver Pin No. (15 way HD D-type)	Console Pin No. (16 way header)	Signal Name	Signal Direction	Signal Function	Signal Characteristics
Line Audio OUT pair	5 Console interface 2	2	LS_LINE_1 <sup>3</sup>	Line output from audio subsystem.	LINE AUDIO OUT See note 3 above	Maximum output (≅peak DAC output) 1.25 V <sub>pk</sub> sine, a.c. coupled, into 600 Ω load.
	6 Console interface 2	4	LS_LINE_2	Output from audio subsystem	Ground return for audio line output.	Ground to audio star point
Line Audio IN pair	7 Console interface 2	1	MIC_LINE_SIG	Line input to audio subsystem	LINE AUDIO IN See note 3 above	Audio in: maximum operating level (≅ FSD on speech ADC) 0.65 V <sub>pk</sub> sine, AC coupled, into 600 Ω load impedance.
	8 Console interface 2.	3	MIC_LINE_GND	Input to audio subsystem.	Ground return for microphone input.	Main ground via 100 Ω resistor. Input voltage < 0.3 V (to ensure input functions as microphone input).
	metal shell	6	Screen	-	Over-all cable screen	Connect to digital GND

It is expected that a 3<sup>rd</sup> party will construct a bespoke cable to bring the above connections into use.

A splitter/breakout box (300-00221) is available to allow both connection of a Console and facilitate simple connection by a third party cable (see over leaf).



Only one of these options may be programmed at a time using the Radio Manager.

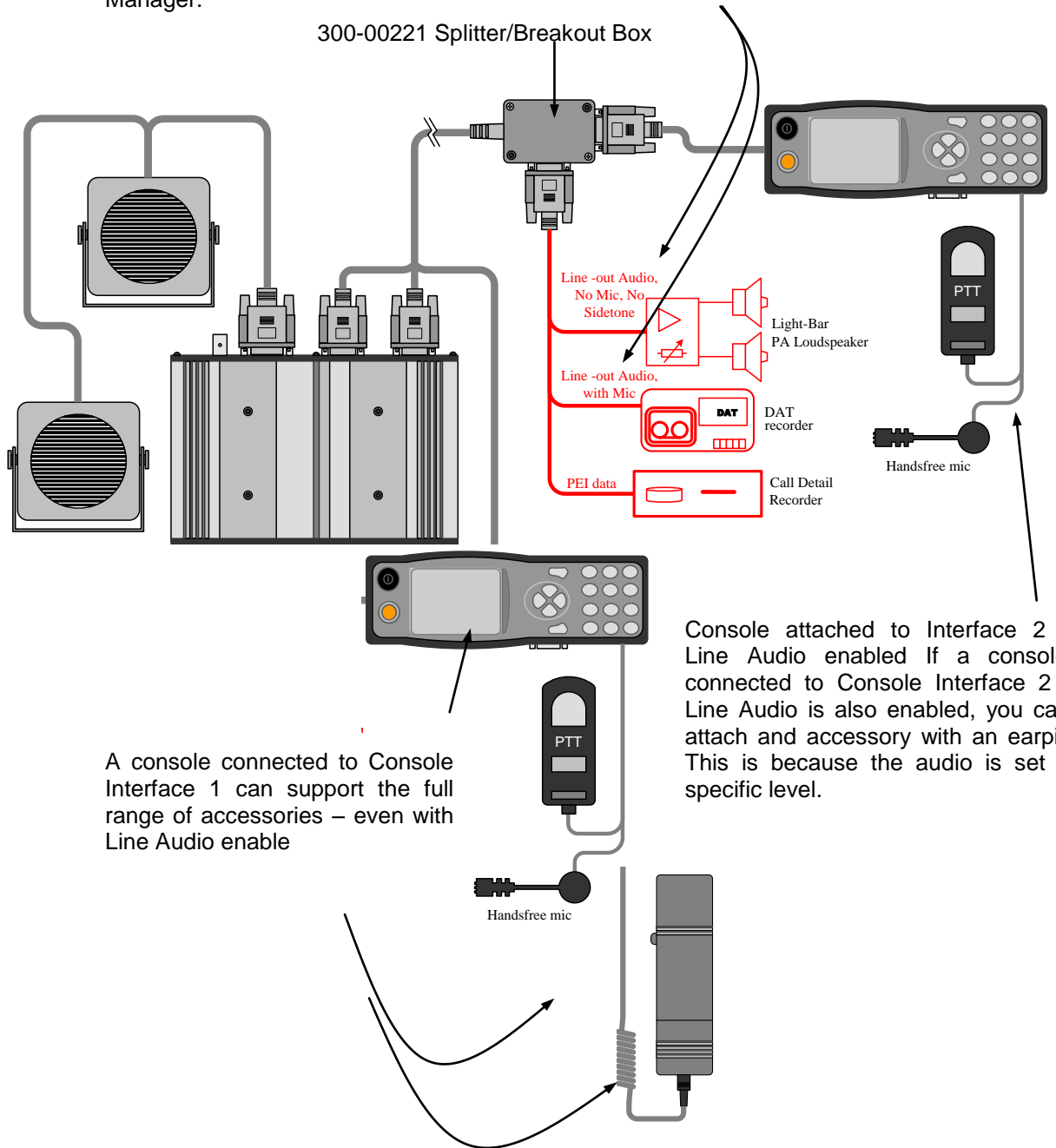

A console connected to Console Interface 1 can support the full range of accessories – even with Line Audio enable

Console attached to Interface 2 with Line Audio enabled If a console is connected to Console Interface 2 and Line Audio is also enabled, you cannot attach and accessory with an earpiece. This is because the audio is set at a specific level.

The above shows a just one possible installation option with two consoles, the splitter/breakout box together with what accessories may be attached whilst Console Interface 2 is programmed to support Line Level Audio.

A third-party MDT manufacturer could equally attach his MDT audio IN and OUT in place of the items shown in Red above

For more details - please refer to:

- Feature Description V9 bulletin number MOD-08-538 for details on the options available whilst using Line Level Audio.
- Radio Manager v1.5 onwards

## POWER SUPPLY INTERFACE

There is a single Power Supply Interface located on the rear panel of the Transceiver.

### CONNECTOR DETAILS

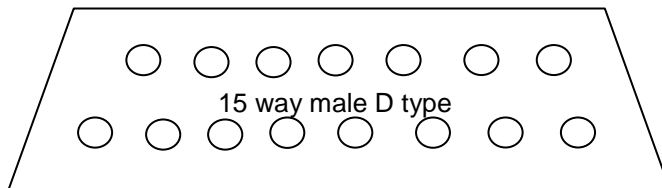

Connector viewed from the rear of Transceiver.

### SIGNAL DETAILS

Pin Number	SRM Signal Name	Input/Output	SRM2 Description	Performance
1,2,9,10	GND_CAR	I	Supply input	0V
4,5,11,12	12V_CAR	I	Supply input	17V absolute max. 15.6V max operating 13.2V nominal, 10.8V min. operating Abs. max operating current 7.5A See notes below. I(off) <5mA I(stby, registered) <450mA I(rx, speech full volume) <2.3A I(Tx, 10W single slot) <5.1A All currents assume a single Console connected. Reverse polarity protection (see note 9)
3	IGN_SENSE	I	On-Off	See notes overleaf.
6	LS_B	O	Loudspeaker	See signal LS_A

Pin Number	SRM Signal Name	Input/Output	SRM2 Description	Performance
7	GPI_1	I	Programmable I/O input 1	<p>VIH min = 2.0V</p> <p>VIL max = 0.8V</p> <p>Protected against accidental application of vehicle supply voltage</p> <p>Assertion time: &gt;100ms</p> <p>(see also note 10)</p>
8	GPI_3	I	Programmable I/O input 3	<p>VIH min = 2.0V</p> <p>VIL max = 0.8V</p> <p>Protected against accidental application of vehicle supply voltage</p> <p>Assertion time: &gt;100ms</p> <p>(see also note 10)</p>
13	LS_A	O	Loudspeaker	<p>Typical solution is a balanced 4 ohms single speaker with 8W maximum load power.</p> <p>The speaker drive is rated to support two parallel 4 ohm speakers in a balanced 2 ohm configuration.</p> <p>Speakers with power rating of less than 8W may be prone to damage.</p> <p>See section 5.3</p>
14	ODO_1	O	Programmable I/O output	<p>Open drain, active low.</p> <p>500mA max sink current</p> <p>15.8V max external voltage</p> <p>Protected against inductive loads.</p> <p>VOL max = 200mV @ 0.5A</p>
15	GPI_2	I	Programmable I/O input 2	<p>VIH min = 2.0V</p> <p>VIL max = 0.8V</p> <p>Protected against accidental application of vehicle supply voltage</p> <p>Assertion time: &gt;100ms</p>

Pin Number	SRM Signal Name	Input/ Output	SRM2 Description	Performance
				(see also note 10)
Screen			Screen	

Notes:

1. The Transceiver will power up if the on/off key (PWR\_ON) is held 'on' on the Transceiver regardless of the state of the ignition (IGN\_SENSE) signal.
2. The Transceiver hardware will power up if the ignition line (IGN\_SENSE) goes high at the same time that the power input goes high and the power input is >10V. The power input must rise at a rate of >100V/s for the product to power up.
3. The Transceiver hardware will power up if the power input is present and >10V and the ignition line (IGN\_SENSE) goes high.
4. The mechanism to switch the transceiver off from the console uses a message sent over the console interface.
5. The Transceiver software is able to turn the Transceiver off even if the ignition (IGN\_SENSE) is high.
6. A Transceiver software parameter 3679 – Inactivity Timer - can be configured so that the Transceiver will switch off immediately the ignition (IGN\_SENSE) goes low or after a defined period of inactivity.
7. Neither of the power up signals; PWR\_ON and IGN\_SENSE, maintains the Transceiver power on (i.e. they are non-latching). The Transceivers own software is responsible for holding the Transceiver internal power supply on.
8. It is NOT possible to disable the ability of Console Mode button to power the radio ON or OFF
9. Reverse polarity protection is provided. When reverse polarity connected a diode allows in excess of 10A to flow through it, this will cause the external fuse to break and cut off the battery power without damaging the radio.
10. There is a pull-down resistance on each digital input. The resistance to ground, will vary in the range 10k to 27k ohms depending on the applied input voltage, this because there is a resistor divider network feeding a transistor junction

**SPEAKER CONFIGURATIONS**

Typically only one 4ohm 8w speaker is connected to the transceiver

However the speaker driver is rated to support two parallel 4ohm speakers in a balanced 2 ohm configuration as shown below.

No dual speaker adapter cable is currently available from Sepura, it is expected that the installer will manufacture an appropriate splitter cable

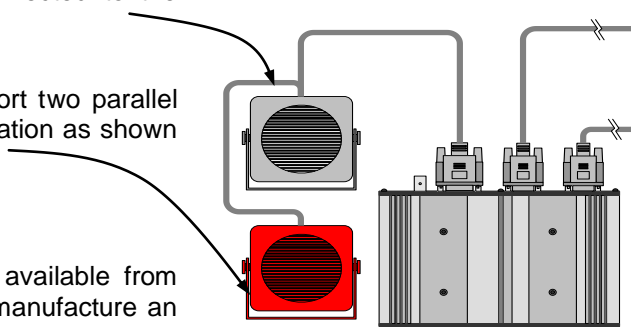

## AUDIO ACCESSORY INTERFACE (AAI)

There are two AAI ports designated AAI1 and AAI2 located on the Console and AIU. A subset of AAI2 connections are duplicated on two jack sockets on AIU Mk1.

AIU Mk2 supports the AAI2 interface via jack connectors only.

NOTE:- Audio side-tone is permanently present for all accessories!

### CONNECTOR DETAILS

Header: Sepura 3513 999 99316

Mating plug: Hirose number DF11-10DS-2C

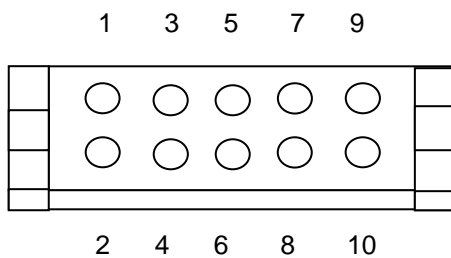

Connector viewed from the rear of the Console or AIU.

### SIGNAL DETAILS

Pin Number	Signal Name	Input/Output	Description	Comment
1	ACC_ID	I	Accessory Identity	5V ADC input with internal 47k pull-up. See section 6.3
2	GND	-	Main Ground return	-
3	SCN	-	Screen Connection	-
4	ACC_KEYS	I	Accessory Keys	5V ADC input with internal 330R pull-up. See section 6.4
5	nON_HOOK	I	Hook Signal	5V CMOS input, active low. Internal 47k pull up to 5V
6	nPTT	I	PTT input	5V CMOS input, active low.

Pin Number	Signal Name	Input/Output	Description	Comment
				Internal 47k pull up to 5V
7	MIC_SIG	I	Microphone input	<p>Console &amp; AIU mk. 1, 2, 3 Sensitivity at “normal” setting = 100 mVpp for max. modulation. Sensitivity at default “high” setting = 10 mVpp for max. modulation. DC bias via internal 2.2 k<math>\Omega</math> pull-up to 3 V when microphone enabled; floating when microphone muted. Zin = 2.2 k<math>\Omega</math>.</p> <p>AIU mk. 2 1, 3 Sensitivity at default “normal” setting = 150 mVpp for max. modulation. Sensitivity at default “high” setting = 15 mVpp for max. modulation. DC bias via internal 4.4 k<math>\Omega</math> pull-up to 3 V. Zin = 1 k<math>\Omega</math>.</p> <p>If microphone resistance &lt; 100 <math>\Omega</math>, “high” sensitivity is selected. Sensitivity = 15 mVpp for max. modulation.</p>
8	MIC_GND	-	Microphone return	-
9	EAR_SIG	O	Earpiece output	32 ohms, power capability = approx 100 mW max. (See note 7 below)
10	EAR_GND	-	Earpiece return	-

## Notes:

1. Transceiver gain set to reference level, see section 6.5
2. The AIU Mk1 has been superseded by the AIU Mk2.
3. There are two audio gain settings: “normal” intended for handheld microphones and “high” intended for remote microphones. If the audio accessory identification resistor (see section 6.3) is 10 k $\Omega$ , or greater, the “normal” gain setting is selected. “High” gain (20 dB higher than “normal” gain) is always selected when the audio accessory identification resistor is 0  $\Omega$ , i.e., ACC\_ID is connected to ground.
4. AIU Mk2 only If the microphone resistance is < 100  $\Omega$ , the gain will be “high”. This functionality is intended to allow dynamic microphones to operate with this interface — as used in certain motorcycle helmet installations.

Accessory ID resistor	Microphone resistance	Gain setting
$\geq 10 \text{ k}\Omega$	$> 1 \text{ k}\Omega$ , e.g., electret	"Normal"
$\geq 10 \text{ k}\Omega$	$< 100 \Omega$ , e.g., moving coil (AIU Mk2)	"High"
$0 \Omega$	any value	"High"

5. The earpiece amplifier does not have any output current limiting resistors fitted and is designed to drive loads with a minimum impedance of  $8 \Omega$  loads from a 5 V supply
6. The transceiver mutes the microphone by turning off the electret microphone DC supply on pin 7 of the AAI. If the audio source is not an electret microphone, then the accessory must implement its own mute by detecting the loss of the DC voltage from this pin.
7. When Normal gain is selected, the presence of a microphone load with a resistance of less than 100 Ohms will automatically select a higher gain signal path. This functionality is intended to allow dynamic microphones to operate with this interface - as used in certain motorcycle helmet installations. The transceiver is unaware of any gain change.
8. These signals and pin out are not compatible with SRM1000 accessories.

#### AUDIO ACCESSORY IDENTITY TABLE

The transceiver identifies audio accessories attached to an AAI through the resistance presented between pin 1 and pin 2 of each AAI.

Audio Accessory Type	Associated identifying resistor value, ohms ( $\pm 2\%$ )	Nominal voltage on ACC_ID pin, V	Nominal ADC value
no device attached	$\infty$	5	255
reserved	220k	4.1	210
local microphone, PTT & hook, (e.g. fist microphone)	100k	3.4	173
local microphone, PTT, earpiece & hook (e.g. handset);	47k	2.5	128
local microphone & PTT without hook (e.g. desk microphone)	22k	1.6	82
local microphone, PTT & earpiece without hook (e.g. headset)	10k	0.88	45
remote microphone & switches without hook;	0	0	0

#### ACCESSORY KEYS TABLE

The transceiver identifies which accessory key is pressed through the resistance presented between pin 4 and pin 2 of each AAI.



Device state	Key press	Nominal voltage on ACC_KEYS pin, V	Nominal ADC value
not attached	N/A	5.00	255
attached	None	4.51	230
attached	0	3.94	201
attached	1	3.35	171
attached	2	2.70	139
attached	3	2.00	102
attached	4	1.46	74
attached	5	0.85	44

The accessory keys use a circuit structure like that given below. Resistor values and associated logical key numbers (which map to functions specified by the Radio Manager) are as follows:

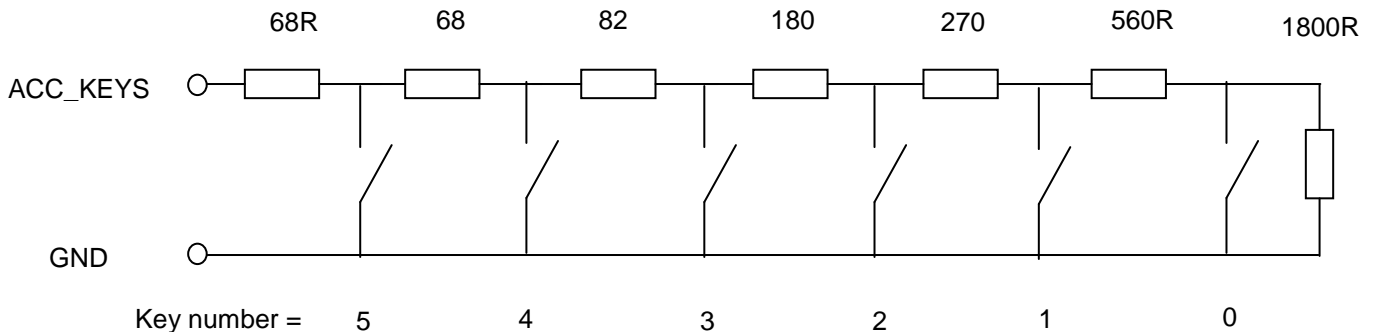

**AUDIO GAIN**

Different microphones require different gains settings, e.g., a fist microphone will usually require a lower gain setting than a remote microphone.

The audio gains of different microphone categories, e.g., fist microphone and headset, can be adjusted over a 45 dB range via Radio Manager. This gain variation takes place in the transceiver and is in addition to the console and AIU sensitivity settings, “normal” and “high”, described in section 6.2. The sensitivities for the console and AIU stated in section 6.2 are achieved when the transceiver audio gain - programmable via Radio Manager - is set to 24 dB.

Accessory	Radio Manager default setting
Covert microphone	30 dB

Radio includes transceiver settings for	Desk Microphone		manager default gain various
	Fist microphone		
	Handset		
	Headset		
	Remote microphone	27 dB	

accessories, but if these are incorrect for a particular customer's needs, the gain can be programmed to any setting within the 45 dB range.

### AIU MK 1 JACK CONNECTORS

Jack sockets provide an alternative method for connecting audio accessories to the AIU Mk1. The jack sockets are an alternative format for the AAI2 connector.

One Jack socket designated 'MIC' supports:

- Microphone audio.
- Accessory ID.

The other Jack socket designated 'PTT' supports:

- PTT.
- Accessory key 5 only.



It should be noted that in the AIU Mk1 the Jack sockets share the AAI2 audio connections; hence accessories must not be plugged in to the Jack sockets and the AAI2 connector at the same time.

### CONNECTOR DETAILS

Stereo 3.5mm Jack socket. Mechanical latching is provided by securing the jack plug body to features in the AIU mounting plate

### JACK SIGNALS

Jack Pin number Identification (for reference):

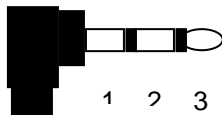

MIC' Jack Socket:

Pin	Signal Name
1	GND
2	ACC_ID (AAI-2 Channel)
3	MIC_SIG (AAI-2 Channel)

'PTT Jack Socket:

Pin	Signal Name	
1	GND	
2	Jack key input	10 k $\Omega$ pull-up to 5 V in the AIU. Connecting this pin to GND via a 22 k $\Omega$ (or less) resistance will cause the console software to see 'Accessory Key 5' pressed on AAI2.
3	nPTT (AAI-2 Channel)	

Note if an SRH side jack microphone is connected in the via the microphone jack socket, the ACC\_ID signal will be shorted to GND (pins 1 and 2 shorted) by the mono jack plug, so the remote microphone accessory will be detected correctly

### AIU MK 2 JACK CONNECTORS

On the Mk 2 version of the Accessory Interface Unit (AIU) some of the pin functionality is re-allocated on the AAI2 connector and the connector is renamed "Remote Control Interface" (RCI) (see section 7).

The AIU Mk 2 has a VOGAD circuit in line with both of the microphone paths. The gain on the AAI1 and AAI2 mic paths can be locally varied according to the type of microphone connected and a microphone detect function is provided on AAI1.

### AAI2 – VIA JACK CONNECTOR

For AIU Mk 2 the AAI2 audio input functionality is only available via the jack connector. The performance and expected signal properties are slightly different from those of AIU Mk 1.

Jack Pin Number	Signal Name	Input/ Output	Description	Performance
3	MIC_SIG	I	Microphone input	Normal gain: 150mV <sub>rms</sub> nominal  High gain: 15mV <sub>rms</sub> nominal  Low gain: 1.2 V <sub>rms</sub> nominal.  2.2 k $\Omega$ internal pull up to 8V.

The higher bias voltage and the addition of microphone load detection, allow this interface to operate with active remote microphones e.g.

Accessory ACC_ID2	ID	resistor,	Microphone resistance or current	Gain setting
$\geq 10 \text{ k}\Omega$			$> 20 \text{ k}\Omega$ ( $< 0.4 \text{ mA}$ ), e.g., passive electret	“Normal”
$\geq 10 \text{ k}\Omega$			$< 100 \Omega$ , e.g., moving coil	“Low”
$\geq 10 \text{ k}\Omega$			$\geq 1.5 \text{ mA}$ , e.g., active electret	“Low”
$0 \Omega$			$> 20 \text{ k}\Omega$ ( $< 0.4 \text{ mA}$ ), e.g., passive electret	“High”

## RCI CONNECTIONS

The RCI is present on the AIU Mk2 only. It allows an RCU to control the features of the transceiver without using the radio console

### CONNECTOR DETAILS

Header: Sepura 3513 999 99316

Mating plug: Hirose number DF11-10DS-2C

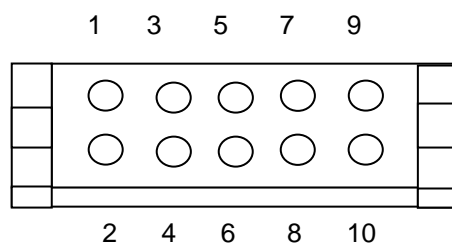

View looking at connector mounted on the AIU Mk 2 PCB.

### SIGNAL DETAILS

Pin Number	Signal Name	Input/Output	Description	Performance
1	8V5	O	Supply output	Supply output to power remote control devices.  8.5v Current limited to ~500mA
2	GND	-	Main Ground return	-
3	DATA	I/O	1-wire data	3v Logic Levels, Sepura proprietary protocol (see note 1 below)
4	ACC_KEYS	I	Accessory Keys	5V ADC input with internal 330R pull-up. See section 6.4
5	nON_HOOK	I	Hook Signal	5V CMOS input, active low.  Internal 47k pull up to 5V
6	nPTT	I	PTT input	5V CMOS input, active low.  Internal 47k pull up to 5V

7	MIC_OUT_SIG	O	Microphone output	Buffered version (0dB gain) of the Jack Microphone input signal. AC coupled with internal 6k8 load resistor to MIC_OUT_GND (see note 3)
8	MIC_OUT_GND	-	Microphone output return	
9	EAR_SIG	O	Earpiece output	32 ohms, power capability = 100 mW max (see note 2 and 3 below).
10	EAR_GND	-	Earpiece return	-

## Notes:

One wire data for support of an RCU such as the Sepura 300-00164

The earpiece amplifier does not have any output current limiting resistors fitted and is designed to drive a minimum of 8ohm loads from a 5V supply.

The MIC\_OUT and EAR signals are no longer supported within the software for this interface.

## DESK MOUNT UNIT CONNECTORS

The transceiver may be mounted within the case and the console mounted on top of a Desk Mount Unit to facilitate operation outside of a vehicle.

The Audio Accessory Interface signals from the AAI1 connector on the back of the Console are cabled to a 9-way 'D' socket and a 1/4" jack socket to allow for connection of a range of desk accessories.

### DESK MICROPHONE/HEADSET CONNECTOR

#### CONNECTOR DETAILS

9-way, standard density D-socket, with 2 off 4-40UNC hex pillars.

#### SIGNALS

The following signals connect back to the AAI1 connector in the back of the Desk Mount Unit console. See section 0 for Signal details.

Pin	Signal Name	Comments
1	ACC_ID	See section 6.3
2	GND	See section 6.2
3	ACC_KEYS	See section 6.4
4	EAR_SIG	See section 6.2
5	EAR_GND	See section 6.2
6	nON_HOOK	See section 6.2
7	MIC_SIG	See section 6.2
8	MIC_GND	See section 6.2
9	nPTT	See section 6.2
Shell	GND	

### FOOT SWITCH CONNECTOR

#### CONNECTOR DETAILS

Panel mounted, 1/4" 3-pole jack socket with a mechanical latching mechanism. (e.g. Neutrik NJ3FP6C).

**SIGNALS**

Pin	Signal Name	Comment
Sleeve	GND	GND
Ring	GND	GND
Tip	nPTT	See section 6.2

**LOUDSPEAKER CONNECTOR**

The Desk Mount Unit has an internal speaker. Connection to the speaker is made on the rear of the unit where there is a 2-pin plug which will accept the speaker connector from the Desk Mount Unit power supply lead.



## DATA CONNECTOR INTERFACE

A single Data Interface Connector is located on:

- The lower surface of the Console.
- On the outside of the AIU.

### CONNECTOR DETAILS

Connector Type: 15 way high density female D type. Type JST KSEY-15S-1A3F19-13

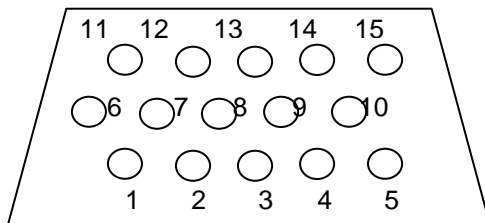

### SIGNAL DETAILS

Pin	Signal Name	Signal Function	Signal Function & Signal Characteristics
1	AODO <sup>1</sup> /MISO	Console Programming & Programmable I/O -Output	Open drain, active low. 500mA max sink current 15.8V max external voltage Protected against inductive loads. An external 10 kΩ pull-up resistor to 5V is required for console programming. See {1} for details $V_{OLmax} = 300mV$
2	MOSI	Console Programming - Input	5V logic. See {1} for details.
3	nReset	Console Programming - Input	5V logic. See {1} for details.
4	SCK	Console Programming - Input	5V logic. See {1} for details.
5	5V	Console Programming - Output	5V nominal, 10mA max. Not protected against misuse.
6	AGPI_1 <sup>1</sup>	Programmable I/O - Input	$V_{IH} min = 2.0V$

Pin	Signal Name	Signal Function	Signal Function & Signal Characteristics
			$V_{IL} \text{ max} = 0.8\text{V}$ Protected against accidental application of vehicle supply voltage Assertion time: >100ms
7	AGPI_2 <sup>1</sup>	Programmable I/O - Input	$V_{IH} \text{ min} = 2.0\text{V}$ $V_{IL} \text{ max} = 0.8\text{V}$ Protected against accidental application of vehicle supply voltage Assertion time: >100ms
8	AGPI_3 <sup>1</sup>	Programmable I/O - Input	$V_{IH} \text{ min} = 2.0\text{V}$ $V_{IL} \text{ max} = 0.8\text{V}$ Protected against accidental application of vehicle supply voltage Assertion time: >100ms
9	RS232_DCD	RS232 Data	See section 4.4
10	RS232_RXD	RS232 Data	See section 4.4
11	RS232_TXD	RS232 Data	See section 4.4
12	RS232_RTS	RS232 Data	See section 4.4
13	RS232_CTS	RS232 Data	See section 4.4
14	RS232_DTR	RS232 Data	See section 4.4
15	GND	-	See section 4.4
Metal shell	Screen	-	See section 4.4

#### Notes

There is a pull-down resistance on each digital input. The resistance to ground, will vary in the range 10k to 27k ohms depending on the applied input voltage, this because there is a resistor divider network feeding a resistor junction

Only the AIU supports digital inputs or outputs, the console does not.

**ANTENNA'S****CONNECTOR DETAILS**

Type: BNC socket.

**SIGNAL DETAILS**

Pin	Signal Name	Signal Function	Signal Function & Signal Characteristics
Centre	ANTENNA	Main TETRA RF input/output	10W max average power (20W max. peak) during transmission DC grounded internally using 100K resistor
Outer	GND	Ground return	Ground

## GPS ANTENNA

### CONNECTOR DETAILS

Type: SMC female (on the radio).

### SIGNAL DETAILS

Pin	Signal Name	Signal Function	Signal Function & Signal Characteristics
Centre	GPS_ANT	GPS RF input and active antenna DC feed	<p>Vnom.5V I max.40mA Internally protected against external short circuits to ground.</p> <p>RF input from GPS antenna = 1575.42 MHz (L1 Band) at a level between -135 dBm and -152 dBm into a 50 <math>\Omega</math> impedance.</p> <p>LNA gain see note 1 below</p>
Outer	GND	Ground return	Ground

#### Notes:

The GPS circuitry within the SRM/G will operate with a passive antenna. However due to cable loss an active antenna with LNA gain between 20dB and 30dB is advised to counter the cable loss. Sepura supplied GPS antennas have an LNA gain of 26dB to counter a 5dB loss in 5m coax cable.

Active antenna's draw 5V dc at up to 40mA.

# CONSOLE AND AIU CABLE SPECIFICATION

In order to connect audio accessories to the Console or AIU, the cable form and its retaining grommet should adhere to the following specification:

## CABLEFORM MECHANICAL DETAILS

Overall dimensions

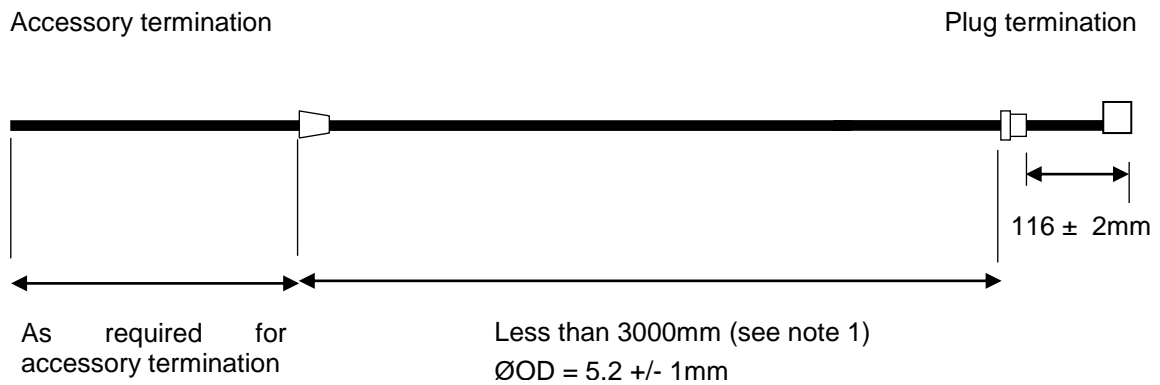

Plug Termination

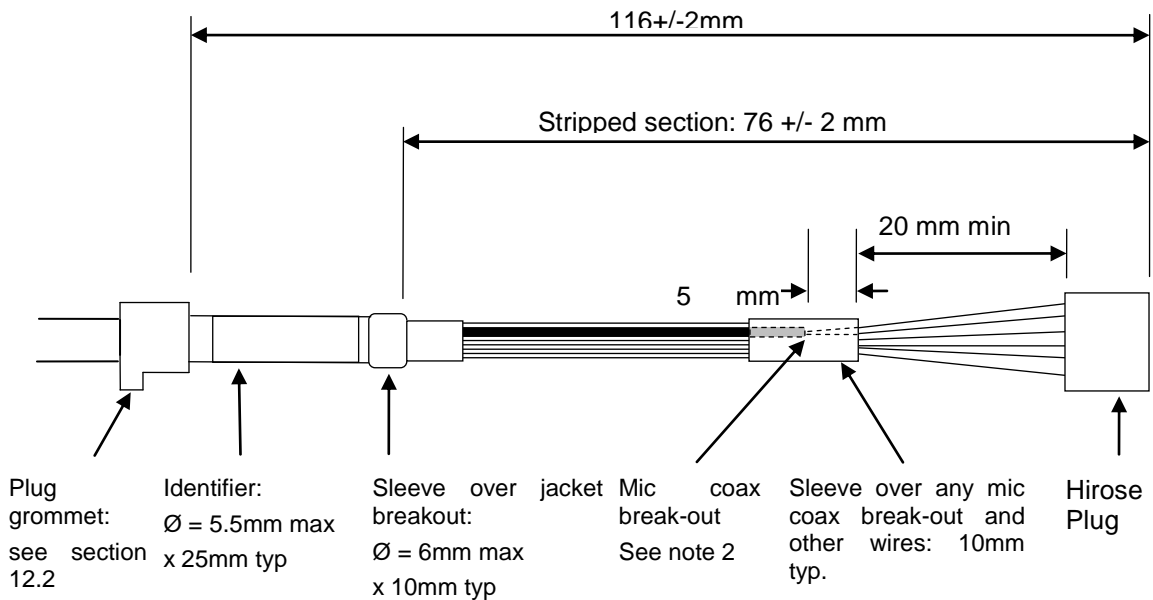

## Notes:

The complete overall length of cable for any accessory including any extension leads must not exceed 3000mm.



Longer cable lengths will require Sepura to obtain further approvals before the accessory may be used, the costs re-approval will be borne by the accessory designer/manufacturer.

In order for the accessory to achieve the required conformity, it is recommended that the cable be overall screened and Mic signals to be additionally screened.

To avoid shorting any exposed length of overall drain and microphone screen must be sleeved with a tight fitting heat shrink to achieve a shrunk-down diameter of approximately 1mm to fit into the insulation crimp of the Hirose pins.

**CABLE FORM GROMMET**

Tolerance: linear dimensions  $\pm 0.1\text{mm}$ , angles  $\pm 1^\circ$

Projection: 3<sup>rd</sup> angle

Fixing method: moulded onto cable.

Material: polyurethane type 58300, shore hardness 80A, colour black.

Pull force: Grommets to withstand a minimum pull force of 100N.

Tooling: Sepura Development to approve gate position prior to tool manufacture.

Surface finish: polished

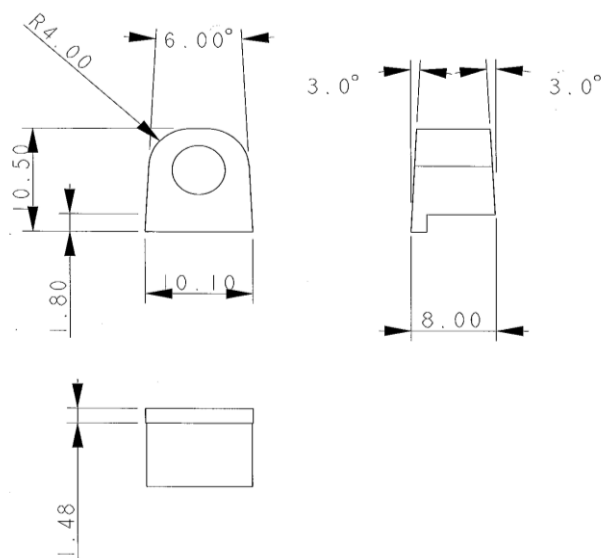

**NOTICE**

All rights reserved. This document may not be reproduced in any form either in part or in whole without the prior written consent of Sepura plc, nor may it be edited, duplicated or distributed using electronic systems.

Company and product names mentioned in this document may be protected under copyright or patent laws.

The information in this document is subject to change without notice and describes only the product defined in this document. This document is intended for the use of Sepura customers and/or other parties only for the purposes of the agreement or arrangement under which this document is submitted, and no part of it may be reproduced or transmitted in any form or means without the prior written permission of Sepura plc.

**CONTACT DETAILS**

Sepura plc  
Radio House  
St Andrew's Road  
Cambridge CB4 1GR  
United Kingdom

Web : [www.sepura.com](http://www.sepura.com)  
Tel: +44 (0)1223 876000  
Fax: +44 (0)1223 879000