

**FLY
EYE**

*VIDEO DRONE THAT'S
YOUR EYE IN THE SKY*

XTREM™



INSTRUCTION MANUAL

SAFETY PRECAUTIONS

NOTICE: Before using the Drone, read this instruction manual carefully, and obey all warnings and caution labels - seriously, it's no fun if someone gets hurt.



WARNING - DO NOT FLY IN RESTRICTED OR NO-FLY ZONES. CHECK YOUR LOCAL LAWS AND REGULATIONS FOR INFORMATION REGARDING THE USE OF UNMANNED AERIAL VEHICLES.



WARNING - THIS DRONE IS NOT INTENDED FOR USE BY CHILDREN UNDER 14 YEARS OLD. ADULT SUPERVISION IS REQUIRED AT ALL TIMES.



CHOKING HAZARD - SMALL PARTS, KEEP OUT OF REACH OF SMALL CHILDREN.



CAUTION - DO NOT TOUCH THE RUNNING PROPELLERS OR FLY OVER SOMEONE'S HEAD.

- Keep hands, hair and loose clothing away from the propellers when the power switch is turned on.
- Always lift off from a flat surface. Never hold the drone in your hand when lifting off.
- Stay away from obstacles and electrical hazards.
- Check the weather conditions. Do not operate the drone in rainy or snowy conditions, or when the wind exceeds 5 MPH (8 KM/H).
- Make sure the controller's antenna is pointing straight up.
- Keep the drone within line of sight - if line of sight to the controller is lost, you may lose control of the drone.
- Always keep a safe distance in all directions around your drone to avoid collisions and/or injury. This drone is controlled by a radio signal subject to interference from many sources outside your control. Interference can cause momentary loss of control.
- Never completely exhaust the battery. When the drone starts to lose power, immediately bring it down safely, and charge the battery as soon as practicable.
- Turn off the controller and drone when not in use.
- Read and obey all warnings and safety guidelines in this manual.
- Regularly examine for any damage to the plugs, propellers and other parts (loose or missing screws). Replace any damaged or loose parts before attempting to fly.

SAFETY PRECAUTIONS

The Drone is equipped with a Lithium Polymer battery. These kind of batteries are light and powerful, as their chemistry is based on lithium, a light and extremely volatile metal.

SPECIAL LIPO BATTERY INSTRUCTIONS:

- Never charge battery unattended.
- Never charge batteries overnight.
- Charge battery in an isolated, controlled environment. Keep far away from flammable materials.
- Do not expose to direct sunlight; there is a risk that the battery may overheat, ignite and/or explode.
- Do not disassemble, modify, heat, or short circuit the battery.
- Do not drop the battery or subject it to strong impacts.
- Do not allow the battery to get wet.
- Only charge the battery with the supplied charging equipment. Using other charging equipment will void your warranty, may damage the battery and poses a risk of fire or explosion.
- If the Drone is not being used for an extended period of time, remove the battery and store it in a cool, dry place out of the reach of children.
- In the unlikely event of leakage or explosion, use sand or a chemical fire extinguisher to extinguish the battery.
- The battery must be recycled or disposed of properly.

BATTERY SAFETY INSTRUCTIONS

- Controller requires 4 x 1.5V AA alkaline batteries (not included).
- Installing/Replacing batteries must be undertaken by a competent adult.
- Do not mix new and old batteries or types of batteries (i.e. alkaline/standard).
- To avoid battery leakage, remove batteries from the controller if the Drone is not being played for a long period of time.
- Promptly remove exhausted batteries. Battery leakage and corrosion can damage the controller.
- Recycle or dispose of used batteries responsibly.



WARNING - MODIFICATIONS NOT APPROVED BY THE PARTY RESPONSIBLE FOR COMPLIANCE COULD VOID USER'S AUTHORITY TO OPERATE THE EQUIPMENT.

YOUR CONTROLLER

Get acquainted with your controller.

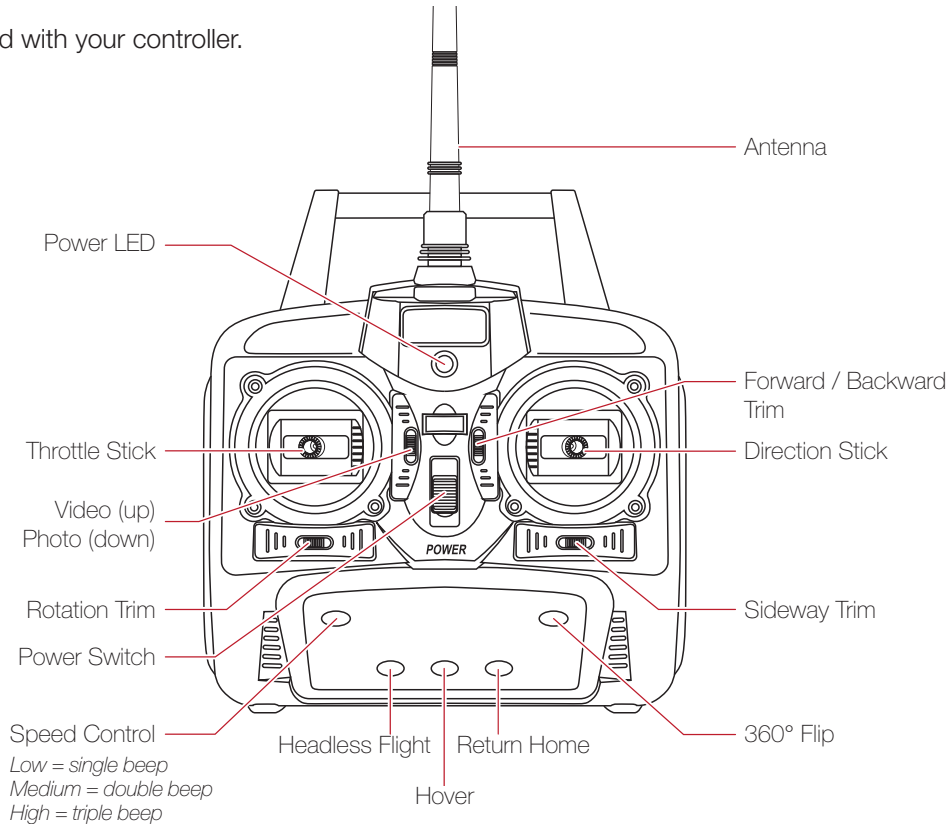

INSTALL CONTROLLER BATTERIES

Your controller requires 4 AA batteries (not included). Open the battery cover of the controller, insert 4 new “AA” (1.5V) alkaline batteries following the polarity markings (+ and -) inside the battery compartment, and then replace the battery cover.

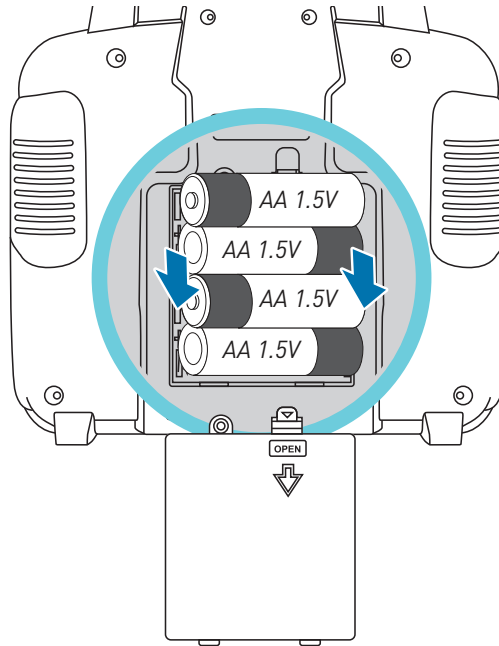

PREPARE FOR FLIGHT

Charge the Drone LiPo battery

Plug the white (3-wire) connector on the LiPo battery into the charging connector on the charger, and then plug the charger into a power outlet. While charging, the charger LED will be solid red. When charging is complete, the charger LED turns green.

⚠ CAUTION

- Only charge the battery with the original charger. Using other charging equipment will void your warranty, may damage the battery, and could result in fire or explosion.
- Promptly remove the battery and disconnect the charger from the power outlet once charging is complete.

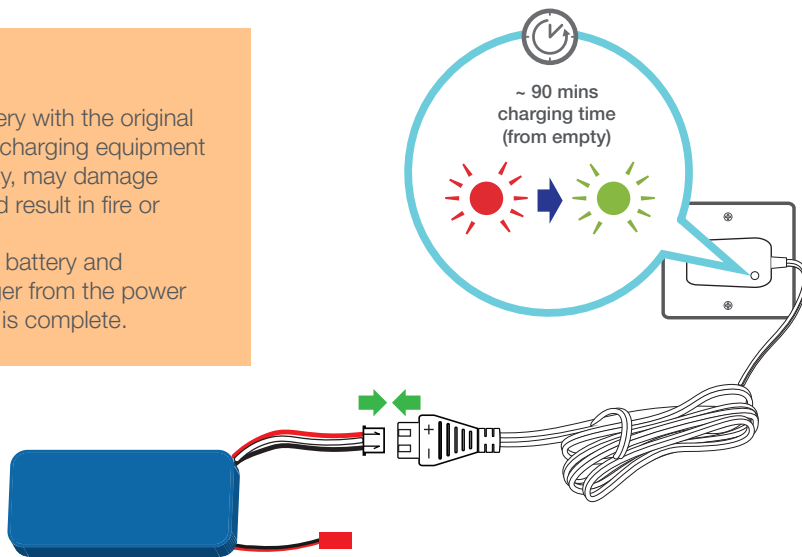

The LiPo battery which is partially charged at shipment. For longest flying time and best performance, fully charge the battery before the first use.

PREPARE FOR FLIGHT

Install the Drone LiPo battery

Once fully charged, plug the red (2-wire) connector on the LiPo battery to the drone's power cable located inside the Drone battery compartment. Stow the LiPo battery and any excess cables inside the battery compartment, and then close the cover.

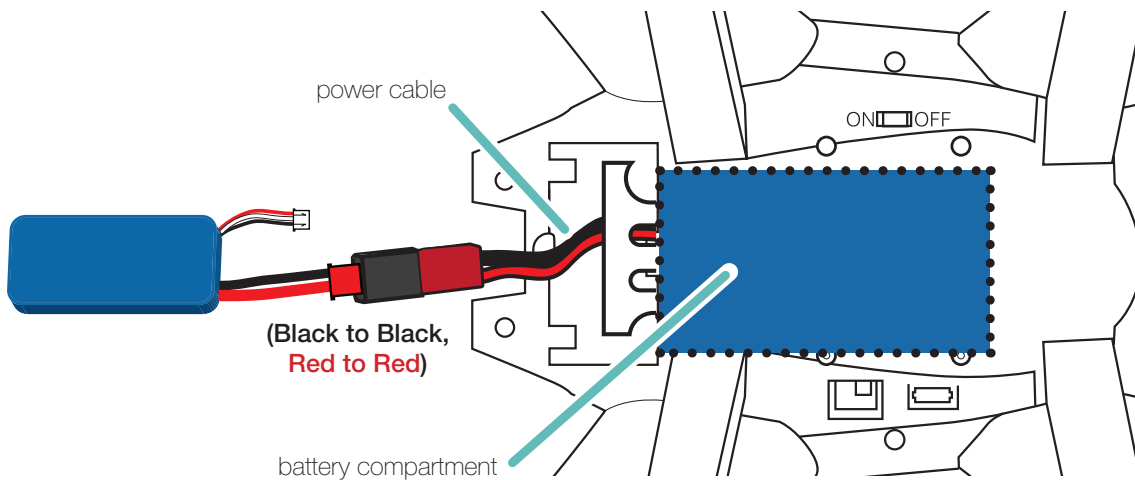

PREPARE FOR FLIGHT

Attach the prop guards

Prop guards prevent propellers from getting damaged or hurting someone, in case of collision.

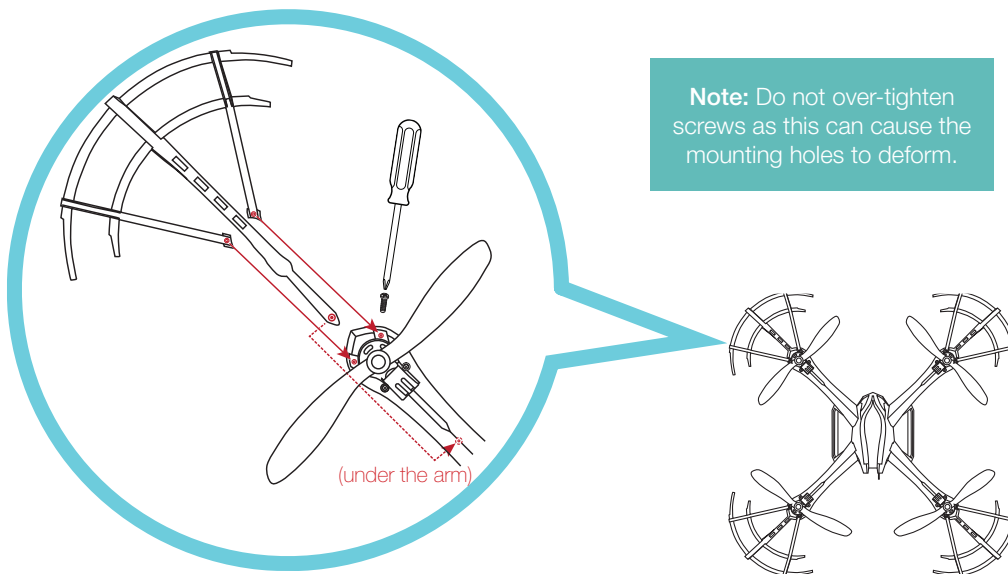

Optional front and rear LED covers can be fitted together with the prop guards under the Drone arms, if necessary. They make it easy to tell which way the Drone is flying.

PREPARE FOR FLIGHT

Attach the landing gear

The set of landing gear provides the Drone a stable platform and protects the bottom-mounted camera during takeoff and landing.

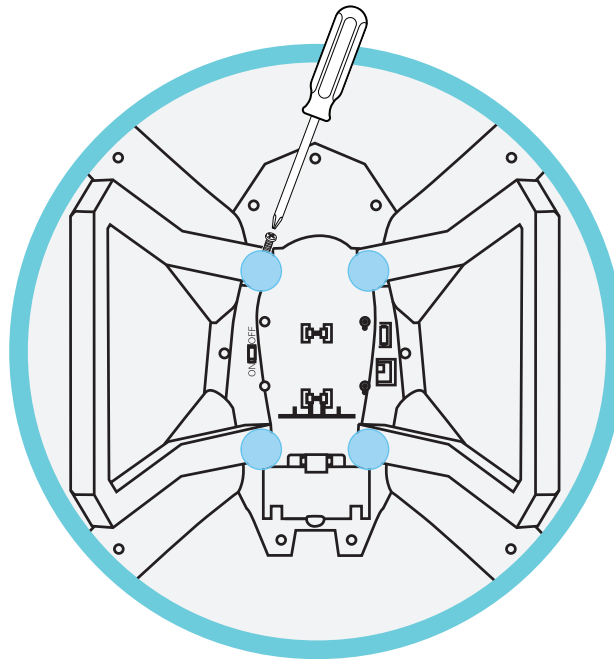

PREPARE FOR FLIGHT

Install the Drone camera

The camera comes pre-fitted with a tilt mount. Simply attach the mount to the four screw posts located underneath the Drone and secure in place using screws. Once mounted, plug the camera's power connector into the "CAMERA" port on the Drone.

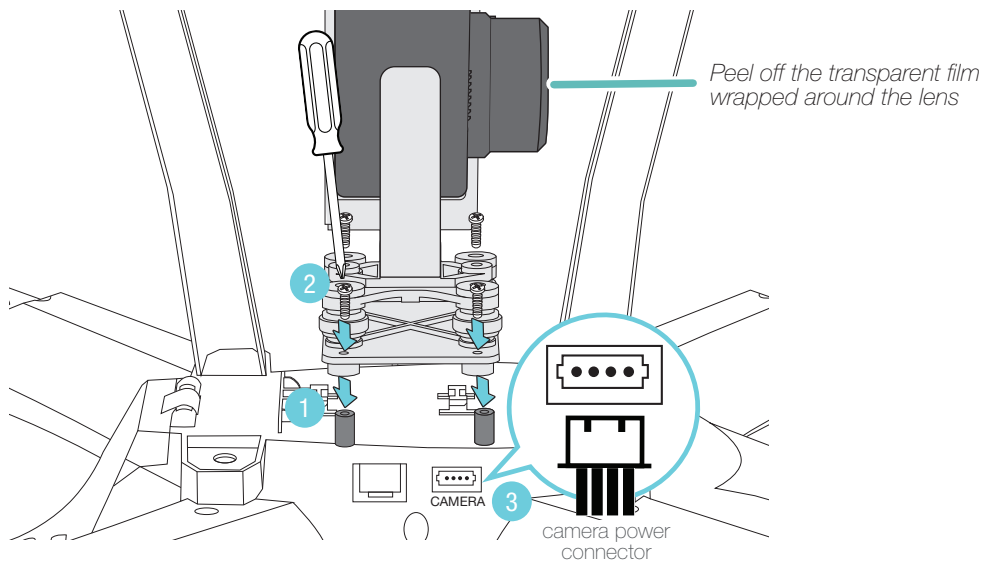

The camera has no internal memory; instead photos and videos are stored on a microSD memory card. Be sure to insert a microSD memory card into the microSD slot on top of the camera.

PREPARE FOR FLIGHT

Pair the controller

- 1 Turn on the Drone and place it on a flat, level surface. Allow up to 10 seconds for the Drone's digital gyroscope to stabilize automatically.

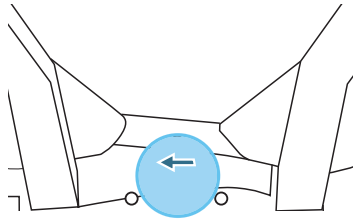

- 2 Turn on the controller. Beginning from a neutral position, move the Throttle stick all the way up and then all the way down. After 2 seconds, the controller stops blinking and beeps once more to indicate successful pairing. The Drone is ready for takeoff.

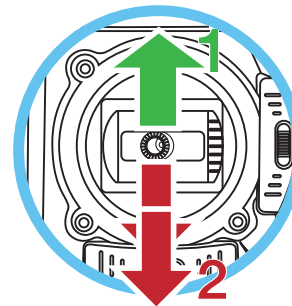
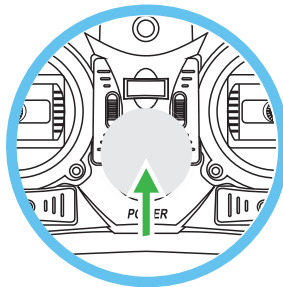

BASIC FLIGHT CONTROLS

The Throttle stick controls altitude (climb/descend) and rotation, while the Direction stick controls forward, backward, and side to side movements.

Throttle stick

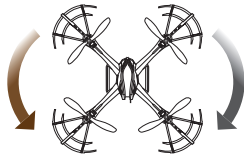
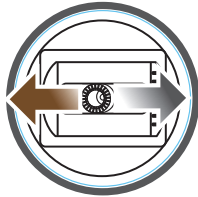
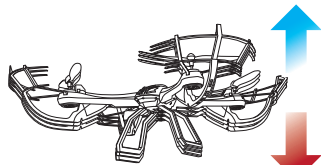
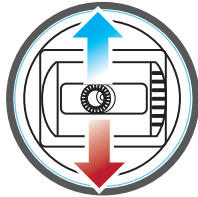

Direction stick

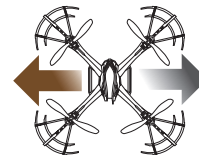
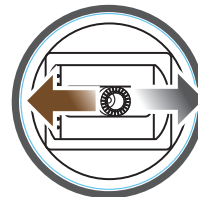
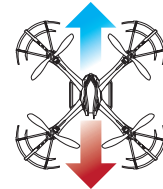
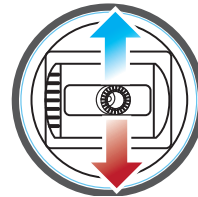

Small adjustments made slowly and carefully are the best way to get the Drone to fly well.

CAPTURE PHOTOS & VIDEOS

Capture awesome aerial action shots and videos with the HD camera.

- To start recording a video, push the Video/Photo button up. While recording is in progress, the Drone's rear LEDs will be blinking. To stop recording, push the Video/Photo button up again.
- To take a photo, push the Video/Photo button down. The Drone's front and rear LEDs will blink once every time a photo is taken.

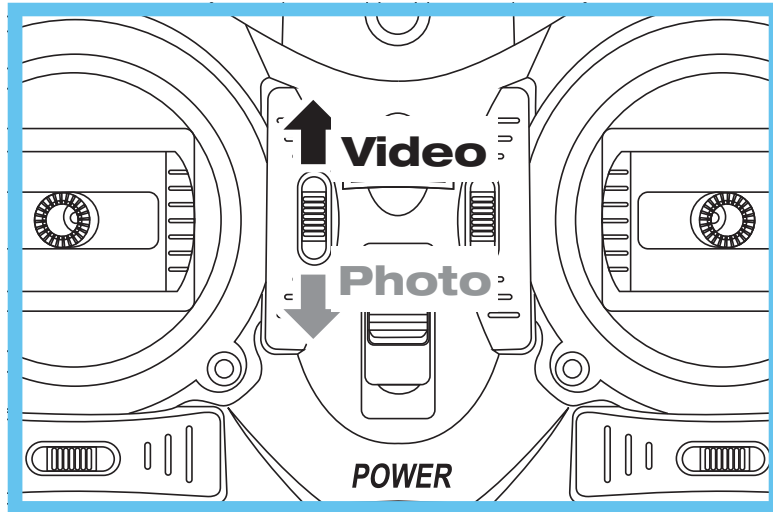

Don't forget to insert a microSD memory card into the microSD slot located on top of the camera before taking off.

RETURN HOME

If you start to lose sight of the Drone during flight, simply press the Return Home button once and the Drone will automatically fly back towards the general vicinity of the controller.

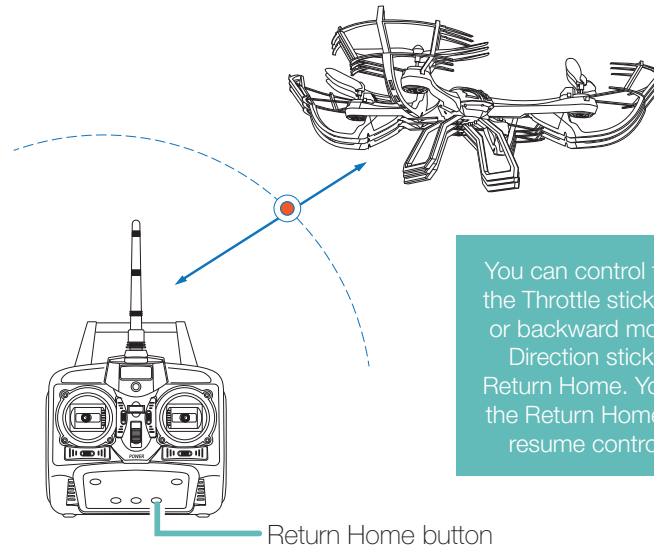

CAUTION - THE DRONE DOES NOT DETECT TREES AND OTHER OBSTACLES IN ITS RETURN TO HOME FLIGHT PATH. TO REDUCE RISK OF COLLISION, BE AWARE OF YOUR SURROUNDINGS AND MAKE SURE THE RETURN PATH IS CLEAR BEFORE ACTIVATING RETURN HOME.

HOVER

Hover mode is a great way for beginners to learn how to fly! This feature maintains the Drone at a consistent altitude while allowing you to rotate and control directional movements normally.

Bring the Drone up to the altitude you want, then press the Hover button. The throttle is automatically controlled and the current altitude is maintained. All other controls (forward, backward, sideway, rotate) will continue to work as usual. To resume control of the throttle and end Hover mode, press the Hover button again.

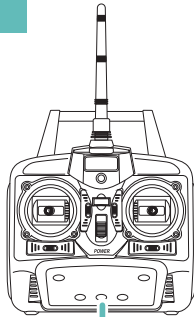

Hover button

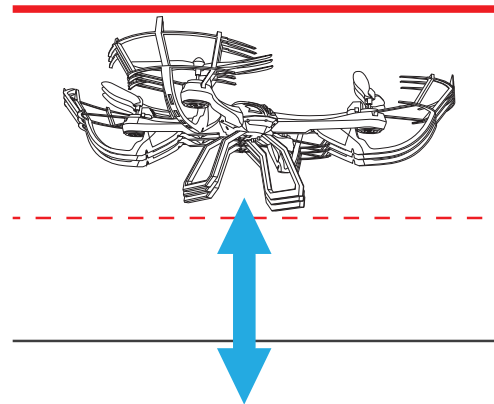

Note: While Hover mode is enabled, the Return Home button does not function.



Make sure the Throttle stick is in the neutral position before turning Hover mode off. This prevents the Drone from dropping or rising suddenly when the throttle control becomes operative again.

HEADLESS FLIGHT

In Headless Flight Mode, the Drone will fly the direction you move the right stick, as seen from your viewpoint, no matter which way the nose is pointed. Push the right stick forward, and the Drone will fly away from you, or push the right stick backward and the Drone will head towards you. Push the right stick left or right and the Drone will move to the left or right relative to you.

Face the Drone, then press the Headless Flight button. The controller beeps continuously to indicate you have activated Headless Flight mode. To cancel this mode, press the Headless Flight button again.

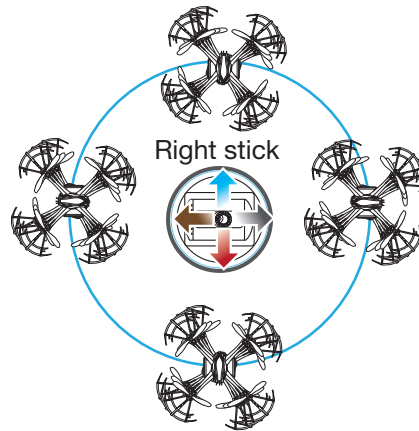
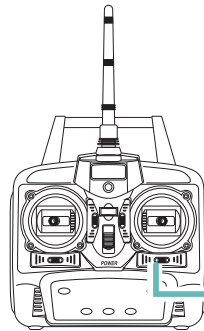

It's super easy to fly when you combine Hover with Headless Flight mode - no throttle control required!

360° FLIP

Perform a 360° flip maneuver by pressing the 360° flip button and moving the Direction stick in the direction you want the Drone to flip. This stunt is best done at least 3 meters above ground in wide-open spaces that are free of obstructions.

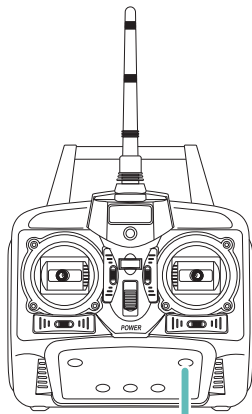

360° Flip button

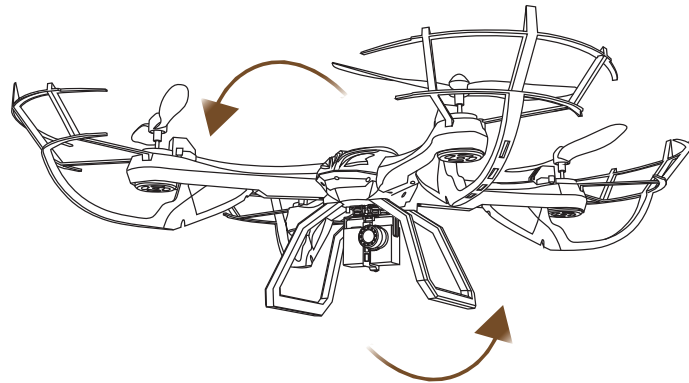

Immediately after flipping the Drone, you need to quickly apply some throttle to restore balance and minimize a sudden loss of altitude.

HELP

Propellers are spinning, but the Drone will not lift off the ground.

- Check the propellers for any sign of damage. Bent or broken propellers should be replaced promptly with the spare propellers included in your package.
- The Drone battery has insufficient power. Make sure the Drone battery has been fully recharged.

The Drone keeps drifting in a certain direction during flight even in calm wind conditions.

- Check for trapped dirt around the motors driving the propellers. Just a little strand of hair could make the Drone difficult to control.
- Adjust the trim to compensate for the drifting. Repeatedly push the appropriate trim adjuster opposite to the direction the Drone is drifting towards until drifting stops. For example, if the Drone drifts forward, push the Forward/Backward Trim adjuster down, and vice-versa. If the Drone drifts to the left, push the Sideway Trim adjuster to the right, and vice-versa. If the Drone spins counter-clockwise, push the Rotation Trim adjuster to the right, and vice-versa.
- Recalibrate the gyro sensor after a heavy landing. First, place the Drone on a flat, level surface, and then hold both control sticks to the lower left corner until the status lights on the Drone blink rapidly. When the lights turn solid, the calibration process is complete.

The Drone responds slowly and does not maintain altitude easily.

- Battery voltage (power) is running low. Before power to the motors is cut off entirely, gradually lower the throttle stick until the Drone descends and lands safely, and immediately charge the battery.
- The Drone has flown outside of the range of the controller. Bring the Drone closer to your position.

Video recording is not smooth. Horizontal lines intermitently appear.

- Signal interference with other 2.4GHz devices in the vicinity of the Drone may cause horizontal lines to appear in the video recording. The lines may also appear when the camera is in challenging lighting conditions such being exposed to bright light and dark shadows simultaneously.
- If your GoPro® camera is mounted to the Drone with the included GoPro® bracket, try changing your GoPro® video resolution setting to 60fps to reduce any rolling shutter effect in the video recording.

The controller is blinking and beeping continuously.

- Batteries need replacing. Insert a new set of AA batteries into the controller.

FAQ

How do I clean and maintain my Drone?

- Regularly inspect and clean any dirt trapped around the propellers using a soft brush. Accumulation of dirt puts additional stress on the motor and may cause the propeller to spin unevenly or even stop spinning completely.
- Wipe clean with a slightly damp cloth.
- Do not submerge in water. This will damage the electronic components.

How long can my Drone fly for?

- You should be able to fly your Drone for at least 10 minutes based on typical conditions before another battery recharge is needed. We have included an extra battery in the package, so you can enjoy double the playing time.

How do I access the photos and videos taken with the Drone camera?

- Turn off the Drone. Eject the microSD card from the Drone camera, then insert it into the included USB card reader. Plug the USB card reader into the USB port on your computer. Playing videos directly from the memory card may cause the videos to be slow or jerky. It is best to copy or transfer files to your computer before trying to watch them.

Do I need to register my Drone?

- Registration is mandatory in the United States because the Drone weighs more than 0.55 lbs. For more information on registering your Drone, please visit www.faa.gov/uas/registration/faqs
- For other parts of the world, please check with your country's civil aviation authority regarding the operation of the Drone in your local airspace. Here are some useful links:
Australia: www.casa.gov.au/aircraft/landing-page/remotely-piloted-aircraft-system
Canada: www.tc.gc.ca/eng/civilaviation/standards/standards-4179.html
UK: www.caa.co.uk/Commercial-Industry/Aircraft/Unmanned-aircraft/Unmanned-Aircraft

Limited Warranty Terms & Conditions

Xtreem warrants this product against defects in workmanship and material for a period of one (1) year from its original purchase date. You must present your receipt as proof of date of purchase for warranty validation. Any unit which proves defective during the stated period will be repaired without charge for parts or labour or replaced at the sole discretion of Xtreem. The end user is responsible for all freight charges incurred to send the product to Xtreem's repair centres. The end user is responsible for all shipping costs incurred when shipping from and to any country other than the country of origin.

The warranty does not cover any incidental, accidental or consequential damages arising from the use of or the inability to use this product. Any costs associated with the fitting or removal of this product by a tradesman or other person or any other costs associated with its use are the responsibility of the end user. This warranty applies to the original purchaser of the product only and is not transferable to any third party. Unauthorized end user or third party modifications to any component or evidence of misuse or abuse of the device will render all warranties void.

By law some countries do not allow limitations on certain exclusions in this warranty. Where applicable by local laws, regulations and legal rights will take precedence.

For Australia: Our goods come with guarantees which cannot be excluded under Australian Consumer Law. You are entitled to a replacement or refund for a major failure and for compensation for any other reasonably foreseeable loss or damage. You are also entitled to have the goods repaired or replaced if the goods fail to be of acceptable quality and the failure does not amount to major failure.



www.xtreemfun.com

MFLYEYE180416E
© XTREEM 2016

NOTE: This equipment has been tested and found to comply with the limits for a Class B digital device, pursuant to part 15 of the FCC Rules. These limits are designed to provide reasonable protection against harmful interference in a residential installation. This equipment generates, uses and can radiate radio frequency energy and, if not installed and used in accordance with the instructions, may cause harmful interference to radio communications. However, there is no guarantee that interference will not occur in a particular installation. If this equipment does cause harmful interference to radio or television reception, which can be determined by turning the equipment off and on, the user is encouraged to try to correct the interference by one or more of the following measures:

- Reorient or relocate the receiving antenna.
- Increase the separation between the equipment and receiver.
- Connect the equipment into an outlet on a circuit different from that to which the receiver is connected.
- Consult the dealer or an experienced radio/TV technician for help.

This device complies with part 15 of the FCC rules. Operation is subject to the following two conditions:

- (1) this device may not cause harmful interference, and
- (2) this device must accept any interference received, including interference that may cause undesired operation.

Changes or modifications to this unit not expressly approved by the party responsible for compliance could void the user's authority to operate the equipment.