

SKYTAB

S-series

Quick Start Guide

9.7" SKYTAB Tablet PC



S970-1020

Powered by **EXOPC**

1. Introduction

- Witness the birth of the next-generation tablet PC by SKYTEX. Harnessing the synergy of Intel's Atom processor and Windows 7, the SKYTAB offers a satisfying multi-touch tablet PC experience like no other.
- Stay productive on the go with Microsoft Office Starter. Conveniently edit documents, spreadsheets and create graphic-rich slideshows on the fly. Easily connect the tablet to an external monitor or projector to display your dynamic presentations. Surf the web, handle your emails, and submit your reports from anywhere there's an available wifi connection.
- Download, transfer or Stream HD movies, television shows, and online videos. Since it works like any other PC, its Netflix, Hulu and Amazon Instant Video ready. Read eBooks, graphic novels, news and magazines in any format. Play touch optimized games, or connect a mouse and keyboard for more serious gaming

2. Features

- 9.7" (diagonal) LED-backlit touchscreen 1024x768 resolution (132ppi)
- Capacitive touch with 4-points of touch recognition
- Operating System: Windows 7 Home Premium
- CPU: Intel Atom N550 1.5GHz Dual-Core
- RAM: 2GB DDR3 667MHz
- STORAGE: 320GB 5400RPM Hard Drive
- Wireless 802.11b/g/n
- Bluetooth 2.1 + EDR
- GRAPHICS: Intel GMA3150 (Support HDMI to 1080P)
- CAMERA: 1.3MP webcam

3. Specification

- Power Input: 19V 2.1A
- Battery: Lithium Battery 36Wh (7.4V/4800mA)
- Stock temperature: -20~60°C
- Operating temperature: 0~40°C
- Unit size: 190*246*15mm
- One year limited Warranty on parts and labor

- P1-

4. Package Contents

- 9.7" SKYTAB X 1
- Power Adapter X 1
- Quickstart guide X 1
- User Manual X 1
- HDMI Cable X 1
- Warranty card X 1
- eMusic gift card X 1

5. Input/Output Ports

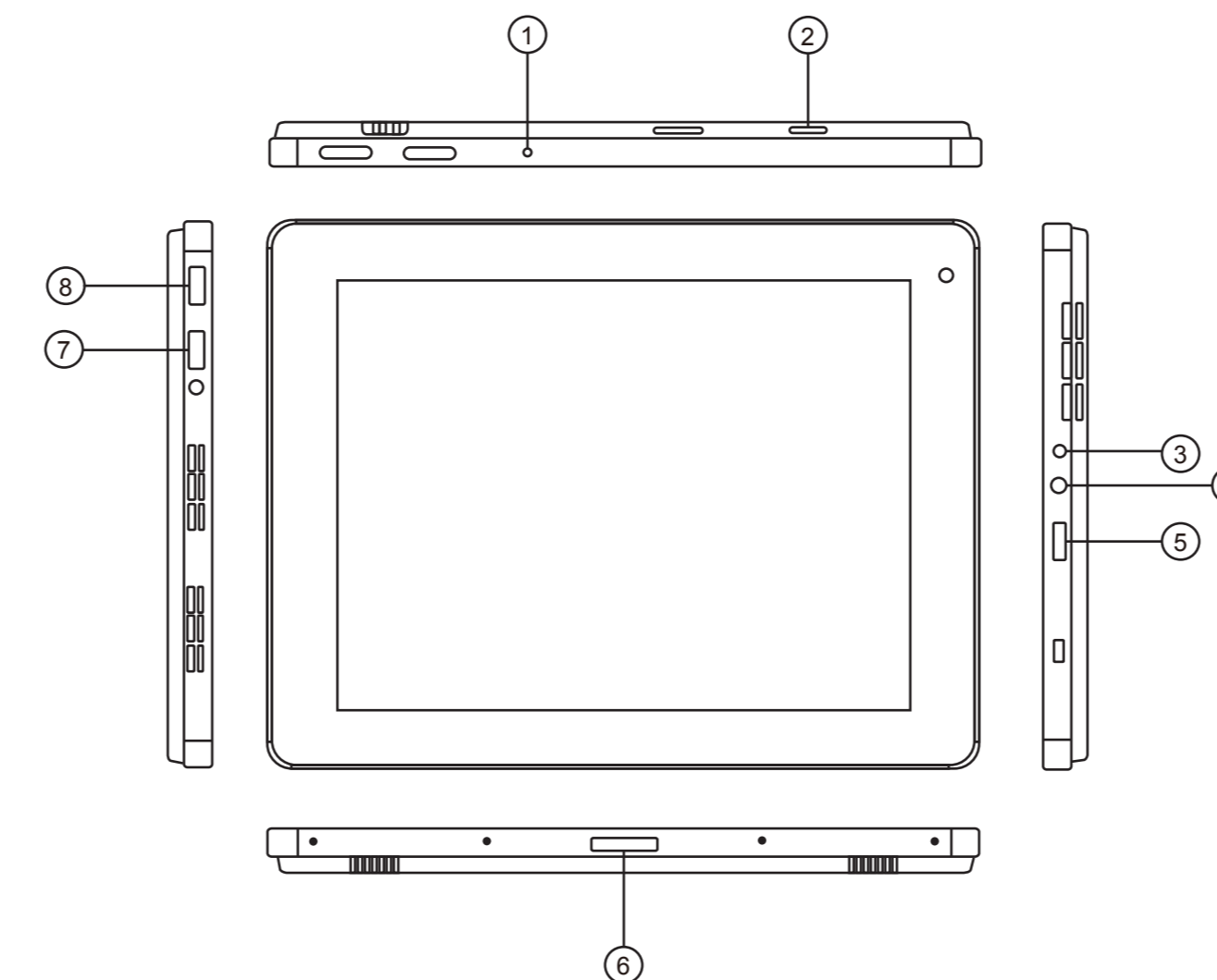

- 1. Microphone
- 2. MicroSD card slot
- 3. 19V 2.1A DC input
- 4. Headphone
- 5. HDMI Output
- 6. Dock connector
- 7. USB 2.0
- 8. USB 2.0

- P2-

6. Keyboard name and function

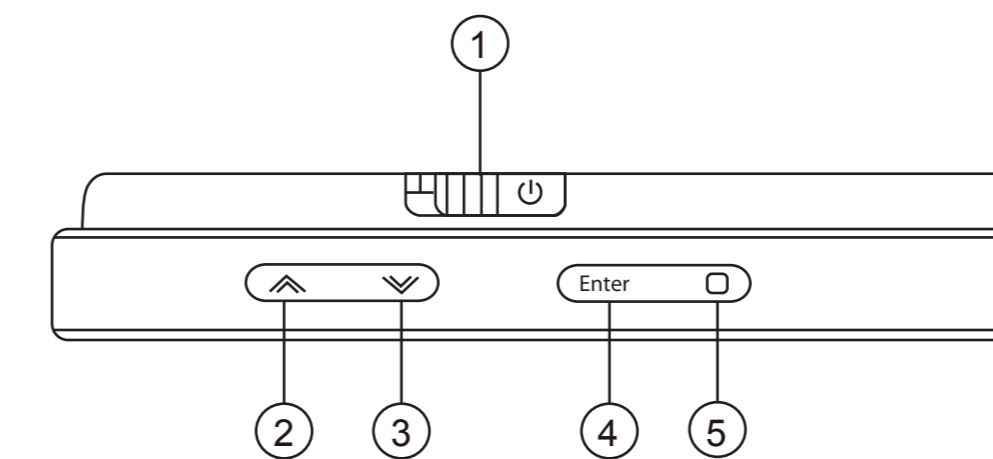

- 1. Power switch
- 2. Volume up
- 3. Volume down
- 4. Enter key (Short click: enter and confirm, long click: right mouse click)
- 5. SAS Key (long click: the same as Ctrl+Alt+Del)

7. Charging

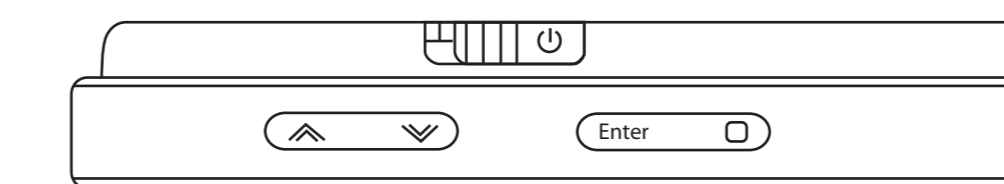

- Power On: LED Red ⇔ LED Green
- Charging: LED Red
- Charged: LED Off

- P3-

8. Troubleshooting

1. There is no audio coming from the earphones.
 - Please check to see that the earphone plug is inserted completely into the jack.
2. The SKYTAB does not turn on .
 - Plug in the power adapter and try again
 - If still does not turn on after battery is fully charged or while the device is plugged in, please contact customer service/tech support.
3. Excess noise/distortion .
 - Please check to see if the earphone plug is clean. dirt may cause noise or distortion.
 - Check that the audio file has not been damaged. Play other music files to see if the issue is widespread. If the file is corrupt, delete it from the device.

For troubleshooting issues related to the Microsoft Windows 7 operating system, please contact Microsoft support: <http://support.microsoft.com/>.

For more info on getting the most from the EXOPC UI, please visit: <http://support.microsoft.com/>.

For contact information and/or troubleshooting, please visit our website at: <http://www.skytex.com/>.

- P4-

FCC Statement:

This device complies with part 15 of the FCC rules. Operation is subject to the following two conditions: (1) this device may not cause harmful interference, and (2) this device must accept any interference received, including interference that may cause undesired operation.

NOTE: The manufacturer is not responsible for any radio or TV interference caused by unauthorized modifications to this equipment. Such modifications could void the user's authority to operate the equipment.

NOTE: This equipment has been tested and found to comply with the limits for a Class B digital device, pursuant to part 15 of the FCC Rules. These limits are designed to provide reasonable protection against harmful interference in a residential installation. This equipment generates uses and can radiate radio frequency energy and, if not installed and used in accordance with the instructions, may cause harmful interference to radio communications. However, there is no guarantee that interference will not occur in a particular installation.

If this equipment does cause harmful interference to radio or television reception, which can be determined by turning the equipment off and on, the user is encouraged to try to correct the interference by one or more of the following measures:

- Reorient or relocate the receiving antenna.
- Increase the separation between the equipment and receiver.
- Connect the equipment into an outlet on a circuit different from that to which the receiver is connected.
- Consult the dealer or an experienced radio/TV technician for help.