

SHARP®

SERVICE MANUAL

S38M107R430BE

MICROWAVE OVEN MODELS R-430BK/R-430BW / R-430BD

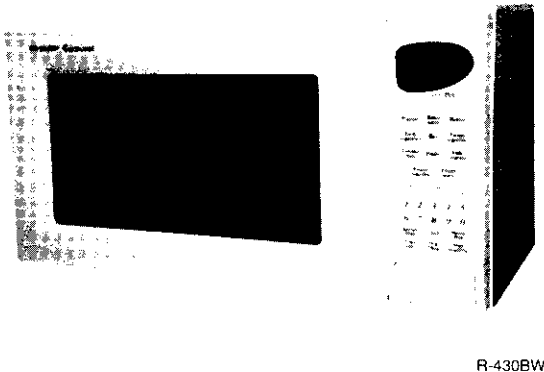

In the interest of user-safety the oven is to be restored to its original condition and only the parts identical to those specified should be used.

WARNING TO SERVICE PERSONNEL: Microwave ovens contain circuitry capable of producing very high voltage and current. Contact with the following parts may result in a severe, possibly fatal electrical shock. (High Voltage Capacitor, High Voltage Power Transformer, Magnetron, High Voltage Rectifier Assembly, High Voltage Harness etc..)

This is a supplemental Service Manual for Microwave Oven models R-430BK, R-430BW & R-430BD. These models are quite similar to the Base Model R-420BK (S/M#S28M104R420BE). This supplemental manual must be used in conjunction with the base model service manual for complete operation, service, safety and replacement parts information.

SECTION	PAGE
PRECAUTIONS TO BE OBSERVED BEFORE AND DURING SERVICE TO AVOID POSSIBLE EXPOSURE TO EXCESSIVE MICROWAVE ENERGY.	Inside Front Cover
Before Servicing	Inside Front Cover
Warning to Service Personnel	1
Foreword and Warning	2
Specifications	3
Key Unit Layout	4
Operation	5
Servicing and Troubleshooting Guide	6
Test Procedures	7
Touch Control Outline	13
Component Replacement and Adjustment Procedure	18
Microwave Measurement Procedure	22
Schematic / Wiring Diagram	23
Parts	28
Packing and Accessories	33

SHARP ELECTRONICS CORPORATION

Service Headquarters: Sharp Plaza, Mahwah, New Jersey, 07430-2135

SERVICE MANUAL

SHARP

Microwave Ovens R-430BK/R-430BW/R-430BD

Foreword

This manual has been prepared to provide Sharp Electronics Corporation personnel with complete operation and service information for Sharp microwave oven models R-430BK/R-430BW/R-430BD.

It is recommended that service personnel carefully study the entire text of this manual so they will be qualified to render satisfactory customer service.

Check interlock switches and the door seal carefully. Special attention must be given to avoid electrical shock and microwave radiation hazards.

NOTE

This supplemental service manual contains update information only. Please refer to base model service manual (R-420BK) for complete service information.

WARNING

Never operate the oven until the following points are ensured:

- (A) The door is tightly closed.
- (B) The door brackets and hinges are not defective.
- (C) The door packing is not damaged.
- (D) The door is not deformed or warped.
- (E) There are no other visible signs of damage to the oven.

DANGER

Certain initial parts are intentionally not grounded and present a risk of electrical shock only during servicing. Service personnel - Do not contact the following parts while the appliance is energized; High Voltage Capacitor, Power Transformer, Magnetron, High Voltage Rectifier Assembly and High voltage Harness.
If provided, Vent Hood, Fan Assembly and Cooling Fan motor.

All of the parts marked "*" on parts list are used at voltages more than 250V.

Removal of the outer case cabinet gives access to voltage above 250V.

All of the parts marked "Δ" on parts list may cause undue microwave exposure, by themselves, or when they are damaged, loosened or removed.

**Sharp Electronics Corporation
Sharp Plaza
Mahwah, New Jersey 07430-2135**

Specifications

General Information

Key Unit Layout

Operation

Troubleshooting /
Test Procedures

Touch Control Panel

Component Replacement
and Adjustment

Microwave Measurement

Schematic Diagram / Wiring

Parts

SPECIFICATIONS

Item	Description
Power Requirements	120 Volts 14 Amperes 1650 Watts 60 Hertz Single phase, 3 wire grounded
Power Output	1100 watts (IEC-705 Test Procedure) Operating frequency of 2450 MHz
Case Dimensions	Width 21 ^{11/16} " Height 12 ^{3/8} " (including feet) Depth 17 ^{3/8} "
Cooking Cavity 1.3 Cu.Ft.	Width 15" Height 8 ^{17/23} " Depth 16 ^{3/4} " Tray Size 14 ^{1/8} " Diameter
Control Complement	<p>Touch Control System Clock (1:00 - 12:59) Timer (0 - 99 min. 99 sec.) Microwave Power for variable cooking Repetition Rate;</p> <p>P-HI (HIGH) Full power throughout the cooking time P-90 approx. 90% of full power P-80 approx. 80% of full power P-70 (MED HIGH) approx. 70% of full power P-60 approx. 60% of full power P-50 (MED) approx. 50% of full power P-40 approx. 40% of full power P-30 (MED LOW) approx. 30% of full power P-20 approx. 20% of full power P-10 approx. 10% of full power P-0 No power throughout the cooking time</p> <p>FEATURES Instant Action Compu Defrost Sensor Cook Minute Plus Kitchen Timer Variable Power (10) 4 Stage Cooking</p>
Oven Cavity Light	Yes
Safety Standard	UL Listed FCC Authorized DHHS Rules, CFR, Title 21, Chapter 1, Subchapter J

OPERATION

DESCRIPTION OF OPERATING SEQUENCE

The following is a description of component functions during oven operation.

Sensor Cooking Condition

When using the REHEAT function, the foods are cooked without figuring time, power level or quantity. When the oven senses enough steam from the food, it relays the information to its microprocessor which will calculate the remaining cooking time and the power level needed for best results.

When the food is cooked, water vapor is developed. The sensor "senses" the vapor and its resistance increases gradually. When the resistance reaches the value set according to the menu, supplementary cooking is started.

The time of supplementary cooking is determined by experiment with each food category and is inputted into the LSI.

The following is an example of how the AH Sensor Works:

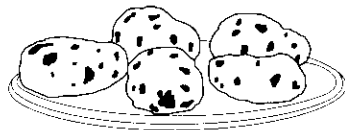

1. Potatoes at room temperature
Vapor is emitted very slowly.

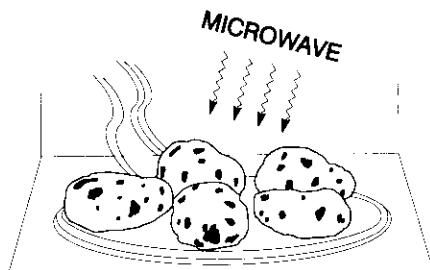

2. Heated potatoes. Moisture and humidity is emitted rapidly. You can smell the aroma as it cooks.

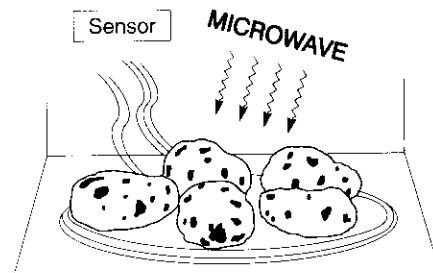

3. Sensor detects moisture and humidity and calculates cooking time and variable power level.

Cooking Sequence

1. Touch REHEAT pad.

Note: The oven should not be operated in either mode immediately after plugging in the unit. Wait five minutes before cooking in sensor mode.

2. The coil to the shut off relay (RY-1) is energized, the oven lamp, turntable motor and cooling fan motor are turned on and the power transformer remains off.

3. After about 16 seconds, the cook relay (RY-2) is energized. The power transformer is turned on, microwave energy is produced and first stage cooking is started.

Note: The 16 second delay is for cooling time required to remove any vapor from the oven cavity and sensor. During this first stage, do not open the oven door or touch the STOP/CLEAR pad.

4. When the sensor detects the vapor emitted from the food, the display switches over the remaining cooking time and the timer counts down to zero.

At this time, the door may be opened to stir food, turn it or season, etc.

5. When the timer reaches zero, an audible signal sounds. The shut-off relay and cook relay are de-energized and the power transformer, oven lamp, etc. are turned off.

6. By opening the door or touching the STOP/CLEAR pad, the time of day will re-appear on the display and the oven will revert to an OFF condition.

TEST PROCEDURES

Procedure Letter

Component Test

G. Touch Control Panel Assembly Test

The touch control panel consists of circuits including semiconductors such as LSI, ICs, etc. Therefore, unlike conventional microwave ovens, proper maintenance can not be performed with only a voltmeter and ohmmeter. In this service manual, the touch control panel assembly is divided into two control units, Control Unit and Key Unit. Troubleshooting by unit replacement is described according to the symptoms indicated.

Before testing

1. Disconnect the power supply cord, and then remove outer case cabinet.
2. Open the door and block it open.
3. Discharge the high voltage capacitor.
4. Disconnect the leads to the primary of the power transformer.
5. Ensure that these leads remain isolated from other components and oven chassis by using insulated tape.
6. After that procedure, re-connect the power supply cord.

1. Key Unit

1. Disconnect the power supply cord, and then remove outer case cabinet
2. Open the door and block it open.
3. Discharge the high voltage capacitor.
4. Check unit ribbon connection before replacement.
5. Reconnect all leads removed from components during testing.
6. Re-install the outercase (cabinet).
7. Reconnect the power supply cord after the outer case is installed.
8. Run the oven and check all functions.

The following symptoms indicate a defective key unit. Replace the key unit.

- a) When touching the pads, a certain pad produces no signal at all.
- b) When touching a number pad, two figures or more are displayed.
- c) When touching the pads, sometimes a pad produces no signal.

If the key unit is defective.

1. Disconnect the power supply cord, and then remove outercase cabinet.
2. Open the door and block it open.
3. Discharge the high voltage capacitor.
4. Replace the key unit.
5. Reconnect all leads removed from components during testing.
6. Re-install the outercase cabinet.
7. Reconnect the power supply cord after the outer case is installed.
8. Run the oven and check all functions.

2. Control Unit

The following symptoms indicate a defective control unit. Before Replacing the control unit, perform the Key unit test (Procedure K) to determine if control unit is faulty.

2-1 In connection with pads.

- a) When touching the pads, a certain group of pads do not produce a signal.
- b) When touching the pads, no pads produce a signal.

2-2 In connection with indicators.

- a) At a certain digit, all or some segments do not light up.
- b) At a certain digit, brightness is low.
- c) Only one indicator does not light.
- d) The corresponding segments of all digits do not light up; or they continue to light up.
- e) Wrong figure appears.
- f) A certain group of indicators do not light up.
- g) All the segments of a digit flicker.

2-3 Other possible problems caused by defective control unit.

- a) Buzzer does not sound or continues to sound.
- b) Clock does not operate properly.
- c) Cooking is not possible.

TEST PROCEDURES

Procedure Letter	Component Test
------------------	----------------

I. *Continued*

Procedures to be taken when the foil pattern of the printed wiring board (PWB) is open

5. Make a visual inspection of the varistor burn damage and test the transformer with an ohmmeter for the presence of layer short-circuit (check the primary coil resistance which is approximately $210\ \Omega \pm 15\%$). If any abnormal condition is detected, replace the defective part(s).

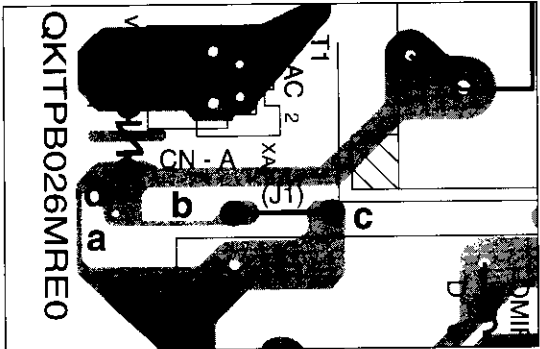

6. Reconnect all leads removed from components during testing.
 7. Re-install the outercase (cabinet).
 8. Reconnect the power supply cord after installing the outer case cabinet.
 9. Run the oven and check all functions.
2. Follow the troubleshooting guide given below. If indicator does not light up after above check and repairs are finished.
1. Disconnect the power supply cord, and then remove outer case cabinet.
 2. Open the door and block it open.
 3. Discharge the high voltage capacitor.
 4. Disconnect the leads to the primary of the power transformer.
 5. Ensure that the leads remain isolated from other components and oven chassis by using insulated tape.
 6. After the above procedure, reconnect the power supply cord.
 7. Follow the troubleshooting guide given below for repair.

Steps	Occurrence	Cause or Correction
1	The rated AC voltage is not present between Pin No.1 of the 2-pin connector (A) and the common terminal of the relay RY1 .	Check supply voltage and oven power cord
2	The rated AC voltage is present at primary side of low voltage transformer.	Low voltage transformer or secondary circuit defective. Check and repair.

8. Disconnect the power supply cord, and then remove the outer case.
9. Open the door and block it open.
10. Discharge the high voltage capacitor.
11. Reconnect all leads removed from components during testing.
12. Re-install the outer case cabinet.
13. Reconnect the power supply cord after the outer case cabinet is installed.
14. Run the oven and check all functions.

TEST PROCEDURES

Procedure Letter	Component Test
L.	<p>AH Sensor Test</p> <p>Checking the initial sensor cooking condition</p> <ol style="list-style-type: none"> The oven should be plugged in at least five minutes before sensor cooking. Room temperature should not exceed 95° F (35° C). The unit should not be installed in any areas where heat and steam are generated. The unit should not be installed, for example, next to a conventional surface unit. Exhaust vents are provided on the bottom of the unit for proper cooling and air flow in the cavity. To permit adequate ventilation, be sure to install so as not to block these vents. There should be some space for air circulation. Be sure the exterior of the cooking container and the interior of the oven are dry. Wipe off any moisture with a dry cloth or paper towel. The sensor works with food at normal storage temperature. For example, chicken pieces would be at refrigerator temperature and canned soup at room temperature. Avoid using aerosol sprays or cleaning solvents near the oven while using Sensor settings. The sensor will detect the vapor given off by the spray and turn off before the food is properly cooked. If the sensor has not detected the vapor of the food, ERROR will appear and the oven will shut off. <p>Water load cooking test</p> <p>Note: The cabinet should be installed and screws tightened. Make sure the oven has been plugged in at least five minutes before checking sensor cook operation.</p> <ol style="list-style-type: none"> Fill approximately 200 milliliters (7.2 oz.) of tap water in a 1000 milliliter measuring cup. Place the container on the center of tray in the oven cavity. Close the door. Touch Reheat pad once and touch the Start pad, Now, the oven is in the sensor cooking operation and "REHEAT" "SENSOR" "COOK" will appear in the display. Now the oven will operate for the first 16 seconds without generating microwave energy. <p>Note: ERROR will appear if the door is opened or Stop/Clear pad is touched during first stage of sensor cooking.</p> <ol style="list-style-type: none"> After approximately 16 seconds, microwave energy is produced, the oven should turn off when water is boiling (bubbling). <p>If the oven does not turn off, replace the AH sensor or check the control unit.</p> <p>Testing Method for AH Sensor and/or Control Unit</p> <p>To determine if the sensor is defective, the simplest method is to replace it with a new sensor.</p> <ol style="list-style-type: none"> Disconnect the power supply cord, and then remove outer case cabinet. Open the door and block it open. Discharge the high voltage capacitor. Remove the AH sensor. Install the new AH sensor. Reconnect all leads removed from components during testing. Re-install the outer case. Reconnect the power supply cord and check the sensor cook operation, proceed as follows: <ol style="list-style-type: none"> Fill approximately 200 milliliters (7.2 oz.) of tap water in a 1000 milliliter measuring cup. Place the container on the center of tray in the oven cavity. Close the door. Touch Reheat pad once and touch the Start pad. The control panel is in automatic Sensor operation. The oven will turn off automatically when the water is boiling (bubbling). <p>If the new sensor does not operate properly, the problem is with the control unit.</p> <p>Checking the Control Unit</p> <ol style="list-style-type: none"> Disconnect the power supply cord, and then remove outer case cabinet. Open the door and block it open. Discharge the high voltage capacitor. Disconnect the sensor connector that is mounted to control panel. Then connect the dummy resistor circuit (see fig. A) to the sensor connector of control panel.

OUTLINE OF TOUCH CONTROL PANEL

The touch control section consists of the following units as shown in the touch control panel circuit:

- (1) Key Unit
- (2) Control Unit (The Control Unit consist of Power Unit and LSI Unit)

The principal functions of these units and their related signals are explained below.

Key Unit

The key unit is composed of a matrix. Signals generated in the LSI are sent to the key unit through P20 - P27. When a key pad is touched, a signal is completed through the key unit and passed back to the LSI through AN8, AN9, AN10 and AN11 to perform the function that was requested.

Control Unit

The Control unit consists of the following:

1. **Synchronizing Signal Circuit**
The Power source synchronizing signal is available in order to compose a basic standard time in the clock circuit. It accompanies a very small error because it works on commercial frequency.
2. **ACL Circuit**
A circuit to generate a signal which resets the LSI to the initial state when power is applied.
3. **Buzzer Circuit**
The buzzer is responsive to signals from the LSI to

emit Audible sounds (key touch sound and completion sound).

4. **Door Sensing Switch**
A switch to "tell" the LSI if the door is open or closed.
5. **Relay Circuit**
To drive the magnetron, fan motor, turntable motor and oven lamp.
6. **Indicator Circuit**
This circuit consists of 45 segments and 5 common electrodes using a liquid Crystal Display.
7. **Back Light Circuit**
A circuit to drive the back light (Light emitting diodes LD1-LD10).
It incorporates a very small error because it works on commercial frequency.
8. **Power Source Circuit**
This circuit generates voltage necessary in the control unit from the AC line voltage.
In addition, the synchronizing signal is available in order to compose a basic standard time in the clock circuit.

Symbol	Voltage	Application
VC	- 5V	LSI (IC1),

9. **Absolute Humidity Sensor Circuit**
This circuit detects the humidity of the food which is being cooked, to control automatic cooking.

Pin No.	Signal	I/O	Description																																																																																																
22	P30	OUT	Signal to sound Buzzer (2.0 kHz). 																																																																																																
23	P31	OUT	Terminal not used.																																																																																																
24	P32	OUT	Common data signal: COM5. Connected to LCD signal COM5 (Pin No. 37).																																																																																																
25-29	P33-P37	OUT	Segment data signal. Connected to LCD. The relation between signals are as follows: <table border="0" style="width: 100%; margin-top: 10px;"> <thead> <tr> <th>LSI signal (Pin No.)</th> <th>LCD (Pin No.)</th> <th>LSI signal (Pin No.)</th> <th>LCD (Pin No.)</th> </tr> </thead> <tbody> <tr><td>P33 (25)</td><td>SEG32 (38)</td><td>SEG 19 (57)</td><td>SEG19 (19)</td></tr> <tr><td>P34 (26)</td><td>SEG33 (39)</td><td>SEG 20 (58)</td><td>SEG20 (20)</td></tr> <tr><td>P35 (27)</td><td>SEG34 (40)</td><td>SEG 21 (59)</td><td>SEG21 (21)</td></tr> <tr><td>P36 (28)</td><td>SEG35 (41)</td><td>SEG 22 (60)</td><td>SEG22 (22)</td></tr> <tr><td>P37 (29)</td><td>SEG36 (42)</td><td>SEG 23 (61)</td><td>SEG23 (23)</td></tr> <tr><td>SEG 1 (39)</td><td>SEG1 (1)</td><td>SEG 24 (62)</td><td>SEG24 (24)</td></tr> <tr><td>SEG 2 (40)</td><td>SEG2 (2)</td><td>SEG 25 (63)</td><td>SEG25 (25)</td></tr> <tr><td>SEG 3 (41)</td><td>SEG3 (3)</td><td>SEG 26 (64)</td><td>SEG26 (26)</td></tr> <tr><td>SEG 4 (42)</td><td>SEG4 (4)</td><td>SEG 27 (65)</td><td>SEG27 (27)</td></tr> <tr><td>SEG 5 (43)</td><td>SEG5 (5)</td><td>SEG 28 (66)</td><td>SEG28 (28)</td></tr> <tr><td>SEG 6 (44)</td><td>SEG6 (6)</td><td>SEG 29 (67)</td><td>SEG29 (29)</td></tr> <tr><td>SEG 7 (45)</td><td>SEG7 (7)</td><td>SEG 30 (68)</td><td>SEG30 (30)</td></tr> <tr><td>SEG 8 (46)</td><td>SEG8 (8)</td><td>SEG 31 (69)</td><td>SEG31 (31)</td></tr> <tr><td>SEG 9 (47)</td><td>SEG9 (9)</td><td>SEG 32 (70)</td><td>SEG37 (43)</td></tr> <tr><td>SEG 10 (48)</td><td>SEG10 (10)</td><td>SEG 33 (71)</td><td>SEG38 (44)</td></tr> <tr><td>SEG 11 (49)</td><td>SEG11 (11)</td><td>SEG 34 (72)</td><td>SEG39 (45)</td></tr> <tr><td>SEG 12 (50)</td><td>SEG12 (12)</td><td>SEG 35 (73)</td><td>SEG40 (46)</td></tr> <tr><td>SEG 13 (51)</td><td>SEG13 (13)</td><td>SEG 36 (74)</td><td>SEG41 (47)</td></tr> <tr><td>SEG 14 (52)</td><td>SEG14 (14)</td><td>SEG 37 (75)</td><td>SEG42 (48)</td></tr> <tr><td>SEG 15 (53)</td><td>SEG15 (15 & 32)</td><td>SEG 38 (76)</td><td>SEG43 (49)</td></tr> <tr><td>SEG 16 (54)</td><td>SEG16 (16)</td><td>SEG 39 (77)</td><td>SEG44 (50)</td></tr> <tr><td>SEG 17 (55)</td><td>SEG17 (17)</td><td>SEG 40 (78)</td><td>SEG45 (51)</td></tr> <tr><td>SEG 18 (56)</td><td>SEG18 (18)</td><td></td><td></td></tr> </tbody> </table>	LSI signal (Pin No.)	LCD (Pin No.)	LSI signal (Pin No.)	LCD (Pin No.)	P33 (25)	SEG32 (38)	SEG 19 (57)	SEG19 (19)	P34 (26)	SEG33 (39)	SEG 20 (58)	SEG20 (20)	P35 (27)	SEG34 (40)	SEG 21 (59)	SEG21 (21)	P36 (28)	SEG35 (41)	SEG 22 (60)	SEG22 (22)	P37 (29)	SEG36 (42)	SEG 23 (61)	SEG23 (23)	SEG 1 (39)	SEG1 (1)	SEG 24 (62)	SEG24 (24)	SEG 2 (40)	SEG2 (2)	SEG 25 (63)	SEG25 (25)	SEG 3 (41)	SEG3 (3)	SEG 26 (64)	SEG26 (26)	SEG 4 (42)	SEG4 (4)	SEG 27 (65)	SEG27 (27)	SEG 5 (43)	SEG5 (5)	SEG 28 (66)	SEG28 (28)	SEG 6 (44)	SEG6 (6)	SEG 29 (67)	SEG29 (29)	SEG 7 (45)	SEG7 (7)	SEG 30 (68)	SEG30 (30)	SEG 8 (46)	SEG8 (8)	SEG 31 (69)	SEG31 (31)	SEG 9 (47)	SEG9 (9)	SEG 32 (70)	SEG37 (43)	SEG 10 (48)	SEG10 (10)	SEG 33 (71)	SEG38 (44)	SEG 11 (49)	SEG11 (11)	SEG 34 (72)	SEG39 (45)	SEG 12 (50)	SEG12 (12)	SEG 35 (73)	SEG40 (46)	SEG 13 (51)	SEG13 (13)	SEG 36 (74)	SEG41 (47)	SEG 14 (52)	SEG14 (14)	SEG 37 (75)	SEG42 (48)	SEG 15 (53)	SEG15 (15 & 32)	SEG 38 (76)	SEG43 (49)	SEG 16 (54)	SEG16 (16)	SEG 39 (77)	SEG44 (50)	SEG 17 (55)	SEG17 (17)	SEG 40 (78)	SEG45 (51)	SEG 18 (56)	SEG18 (18)		
LSI signal (Pin No.)	LCD (Pin No.)	LSI signal (Pin No.)	LCD (Pin No.)																																																																																																
P33 (25)	SEG32 (38)	SEG 19 (57)	SEG19 (19)																																																																																																
P34 (26)	SEG33 (39)	SEG 20 (58)	SEG20 (20)																																																																																																
P35 (27)	SEG34 (40)	SEG 21 (59)	SEG21 (21)																																																																																																
P36 (28)	SEG35 (41)	SEG 22 (60)	SEG22 (22)																																																																																																
P37 (29)	SEG36 (42)	SEG 23 (61)	SEG23 (23)																																																																																																
SEG 1 (39)	SEG1 (1)	SEG 24 (62)	SEG24 (24)																																																																																																
SEG 2 (40)	SEG2 (2)	SEG 25 (63)	SEG25 (25)																																																																																																
SEG 3 (41)	SEG3 (3)	SEG 26 (64)	SEG26 (26)																																																																																																
SEG 4 (42)	SEG4 (4)	SEG 27 (65)	SEG27 (27)																																																																																																
SEG 5 (43)	SEG5 (5)	SEG 28 (66)	SEG28 (28)																																																																																																
SEG 6 (44)	SEG6 (6)	SEG 29 (67)	SEG29 (29)																																																																																																
SEG 7 (45)	SEG7 (7)	SEG 30 (68)	SEG30 (30)																																																																																																
SEG 8 (46)	SEG8 (8)	SEG 31 (69)	SEG31 (31)																																																																																																
SEG 9 (47)	SEG9 (9)	SEG 32 (70)	SEG37 (43)																																																																																																
SEG 10 (48)	SEG10 (10)	SEG 33 (71)	SEG38 (44)																																																																																																
SEG 11 (49)	SEG11 (11)	SEG 34 (72)	SEG39 (45)																																																																																																
SEG 12 (50)	SEG12 (12)	SEG 35 (73)	SEG40 (46)																																																																																																
SEG 13 (51)	SEG13 (13)	SEG 36 (74)	SEG41 (47)																																																																																																
SEG 14 (52)	SEG14 (14)	SEG 37 (75)	SEG42 (48)																																																																																																
SEG 15 (53)	SEG15 (15 & 32)	SEG 38 (76)	SEG43 (49)																																																																																																
SEG 16 (54)	SEG16 (16)	SEG 39 (77)	SEG44 (50)																																																																																																
SEG 17 (55)	SEG17 (17)	SEG 40 (78)	SEG45 (51)																																																																																																
SEG 18 (56)	SEG18 (18)																																																																																																		
30	VSS	IN	Power source voltage: - 5V. VC voltage of power source voltage to drive the LSI is input to VSS terminal. Connected to VC.																																																																																																
31-32	VL3-VL2	IN	Power source voltage input terminal Standard voltage for LCD.																																																																																																
33	VL3	IN	Power source voltage input terminal Standard voltage for LCD. Connected to GND.																																																																																																
34	VCC	IN	Power source voltage GND (0V) The power source voltage to drive the LSI is input to VCC terminal.																																																																																																
35	COM4	OUT	Common data signal: COM1. Connected to LCD signal COM1 (Pin No. 33).																																																																																																
36	COM3	OUT	Common data signal: COM2. Connected to LCD signal COM2 (Pin No. 34).																																																																																																
37	COM2	OUT	Common data signal: COM3. Connected to LCD signal COM3 (Pin No. 35).																																																																																																
38	COM1	OUT	Common data signal: COM4. Connected to LCD signal COM4 (Pin No. 36).																																																																																																
39-69	SEG1-SEG31	OUT	Segment data signal Signal Similar to P33.																																																																																																
70-78	SEG32-SEG40	OUT	Segment data signal Signal Similar to P33.																																																																																																
79	VCC	IN	Power source voltage GND (0V) The power source voltage to drive the LSI is input to VCC terminal.																																																																																																

SERVICING

Precautions for Handling Electronic Components

This unit uses CMOS LSI in the integral part of the circuits. When handling these parts, the following precautions should be strictly followed:

CMOS LSI have extremely high impedance at its input and output terminals. For this reason, it is easily influenced by surrounding high voltage power sources, static electricity charge in clothes, etc. and sometimes it is not fully protected by the built-in protection circuit. In order to protect CMOS LSI, practice the following guidelines:

1. When storing and transporting LSI, thoroughly wrap them in aluminum foil.
Also wrap all PW boards in aluminum foil.
2. When soldering, the technician should use a grounded strap as shown in the figure and use a grounded soldering iron and work table.

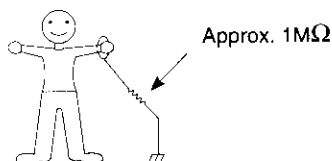

Shapes of Electronic Components

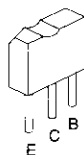

Transistor
2SB1238

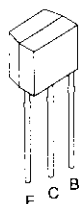

Transistor
KRC243M

Servicing of Touch Control Panel

We describe the procedures to permit servicing of the touch control panel of the microwave oven and the precautions you must take when doing so.

To perform the servicing, power to the touch control panel is available either from the power line of the oven itself or from an external power source.

Servicing The Touch Control Panel With The Oven Power Supply

CAUTION !

The high voltage transformer of the microwave oven is still live during servicing and presents a hazard.

When checking the performance of the touch control panel, put the outer cabinet on the oven to avoid touching the high voltage transformer or unplug the primary terminal (connector) of the high voltage transformer to turn it off; the end of such connector must be insulated with an insulating tape. After servicing, be sure to reconnect the leads to their original locations.

1. On some models, the power supply cord between the touch control panel and the oven itself is so short that

the two can't be separated. For those models, check and repair all the controls (sensor-related ones included) of the touch control panel while keeping it connected to the oven.

2. On some models, the power supply cord between the touch control panel and the oven proper is long enough that they may be separated from each other. For those models, therefore, it is possible to check and repair the controls of the touch control panel while keeping it apart from the oven proper: in this case you must short both ends of the door sensing switch (on PWB) of the touch control panel with a jumper, which brings about an operational state that is equivalent to the oven door being closed.

As for the sensor-related controls of the touch control panel, checking them is possible if dummy resistor (s) with resistance equal to that of the controls are used.

Servicing The Touch Control Panel With An External Power Supply

Disconnect the touch control panel completely from the oven proper, and short both ends of the door sensing switch (on PWB) of the touch control panel, which activates an operational state that is equivalent to the oven door being closed. Connect an external power source to the power input terminal of the touch control panel, then it is possible to check and repair the controls of the touch control panel; it is also possible to check the sensor-related controls of the touch control panel by using the dummy resistor (s).

Servicing Tools

Tools required to service the touch control panel assembly.

1. Soldering iron: 30W
(It is recommended to use a soldering iron with a grounding terminal.)
2. Oscilloscope: Single beam, frequency range: DC-10MHz type or more advanced model.
3. Hand tools.

Other Precautions

1. Before turning on the power source of the control unit, remove the aluminum foil applied for preventing static electricity.
2. Connect the connector of the key unit to the control unit being sure that the lead wires are not twisted.
3. After aluminum foil is removed, be careful that abnormal voltage due to static electricity etc. is not applied to the input or output terminals.
4. Attach connectors, electrolytic capacitors, etc. to PWB, making sure that all connections are tight.
5. Be sure to use specified components where high precision is required.

ABSOLUTE HUMIDITY SENSOR CIRCUIT

Structure of Absolute Humidity Sensor

The absolute humidity sensor includes two thermistors as shown in the illustration. One thermistor is housed in the closed vessel filled with dry air while another is in an open vessel. Each sensor is provided with a protective cover made of metal to protect it from the external air-flow. The open vessel cover has two small holes in it to allow moisture laden air from the oven cavity to surround it.

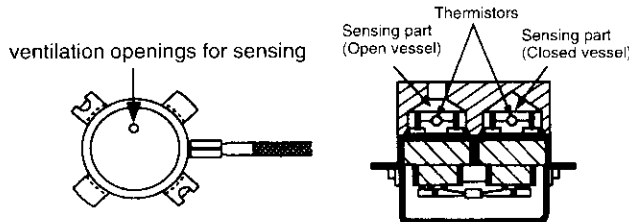

Operational Principle of AH Sensor

The figure below shows the basic structure of an absolute humidity sensor. A bridge circuit is formed by two thermistors and two resistors (R1 and R2).

The output of the bridge circuit is amplified by an operational amplifier.

Each thermistor is supplied with a current to keep it heated to about 150° C (302° F) and the resultant heat is dissipated in the air, if the two thermistors are placed in different humidity conditions they show different humidity conditions and different degrees of heat conductivity leading to a potential difference between them causing an output voltage from the bridge circuit, the intensity of which is increased as the absolute humidity of the air increases. Since the output is very minute, it is amplified by the operational amplifier.

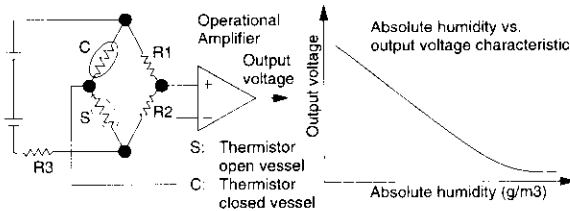

Detector Circuit of AH Sensor Circuit

This detector circuit is used to detect the output voltage of the absolute humidity circuit to allow the LSI to control

the sensor cooking of the unit.

When the unit is set in the sensor cooking mode, 16 seconds later the detector circuit starts to function and the LSI observes the initial voltage available at its AN1 terminal. With this voltage given, the switches SW1 to SW5 in the LSI are turned on in such a way as to change the resistance values in parallel with R107-R111 of IC2. Changing the resistance values results in that there is the same potential at both the F-3 terminal of the absolute humidity sensor and the AN0 terminal of the LSI. The voltage of AN1 terminal will indicate about -2.5V. This initial balancing is set up about 16 seconds after the unit is put in the Sensor Cooking mode.

As the sensor cooking proceeds, the food is heated to generate moisture by which the resistance balance of the bridge circuit is deviated to increase the voltage available at the AN1 terminal of the LSI. Then the LSI observes that voltage at AN1 terminal and compares it with its initial value. When the comparison rate reaches the preset value (fixed for each menu to be cooked), the LSI caused the unit to stop sensor cooking; thereafter, the unit goes into the next operation automatically.

When the LSI starts to detect the initial voltage at AN1 terminal 16 seconds after the unit has been put in the Sensor Cooking mode, if it is impossible to take a balance of the bridge circuit due to disconnection of the absolute humidity sensor, ERROR will reappear on the display and cooking is stopped.

Absolute Humidity Sensor Circuit

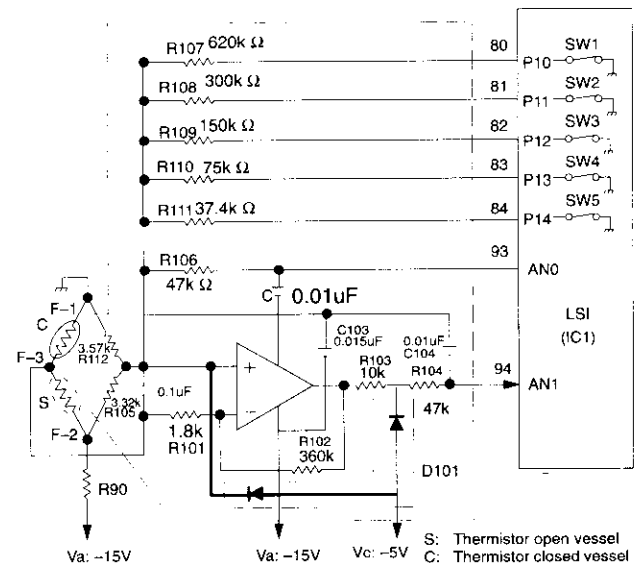

AH SENSOR ORIENTATION & HARNESS ROUTING

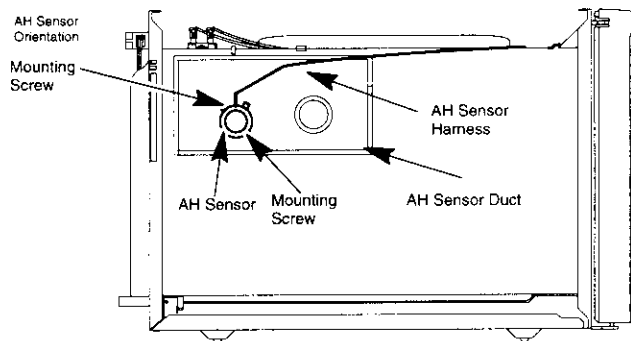

Figure 1-16
Oven Left Side View

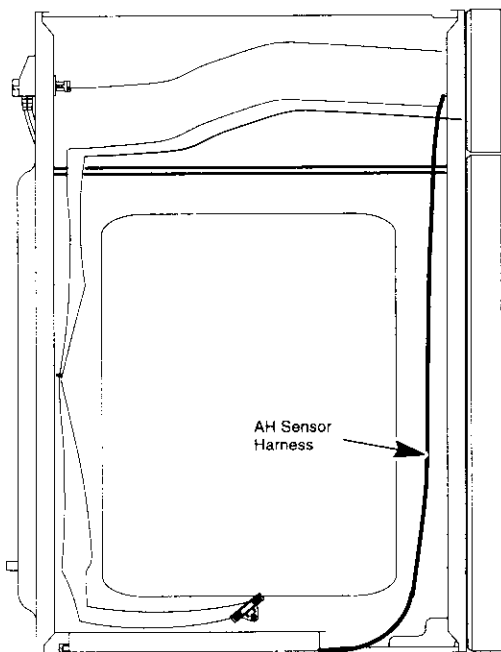
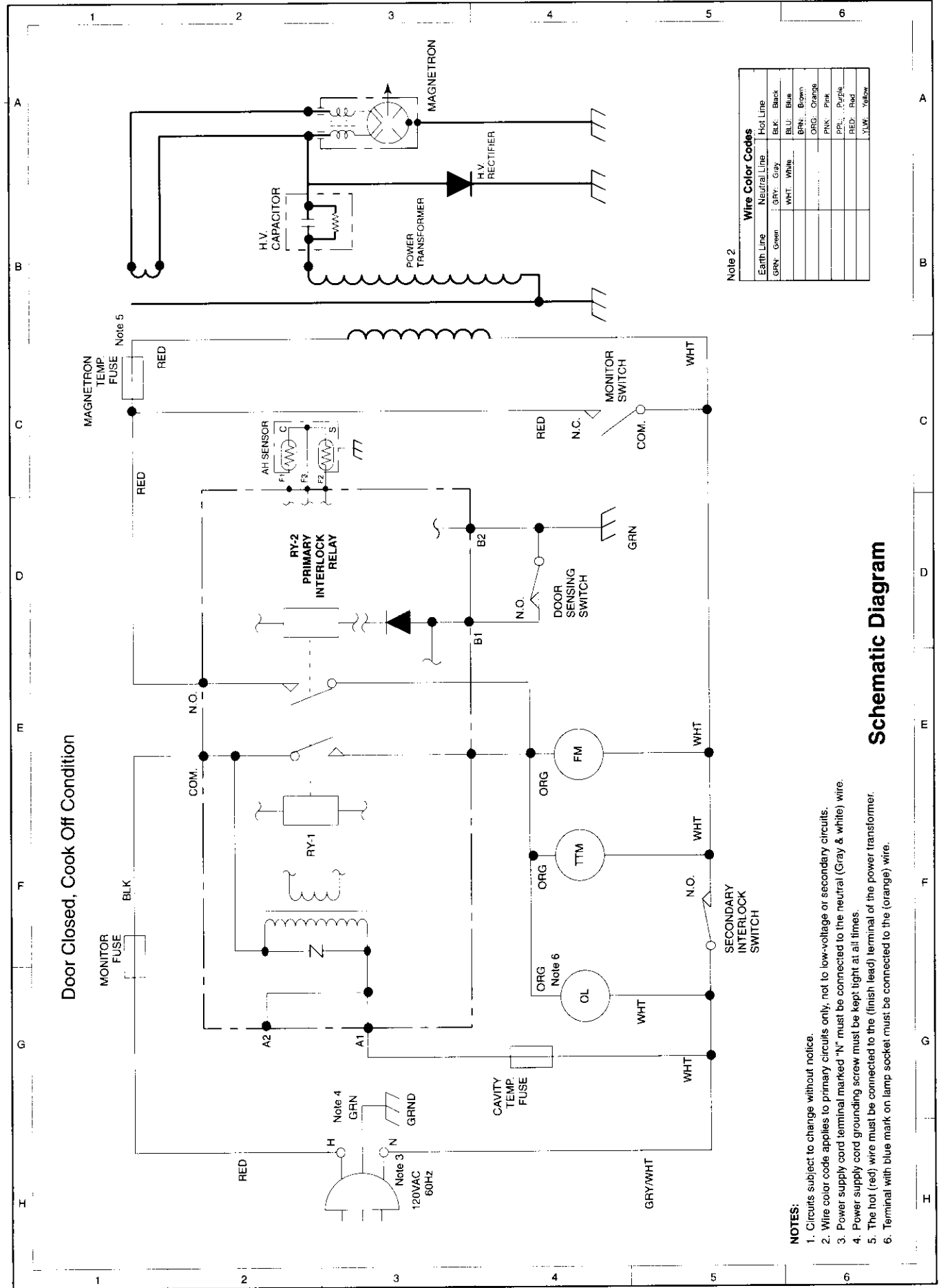
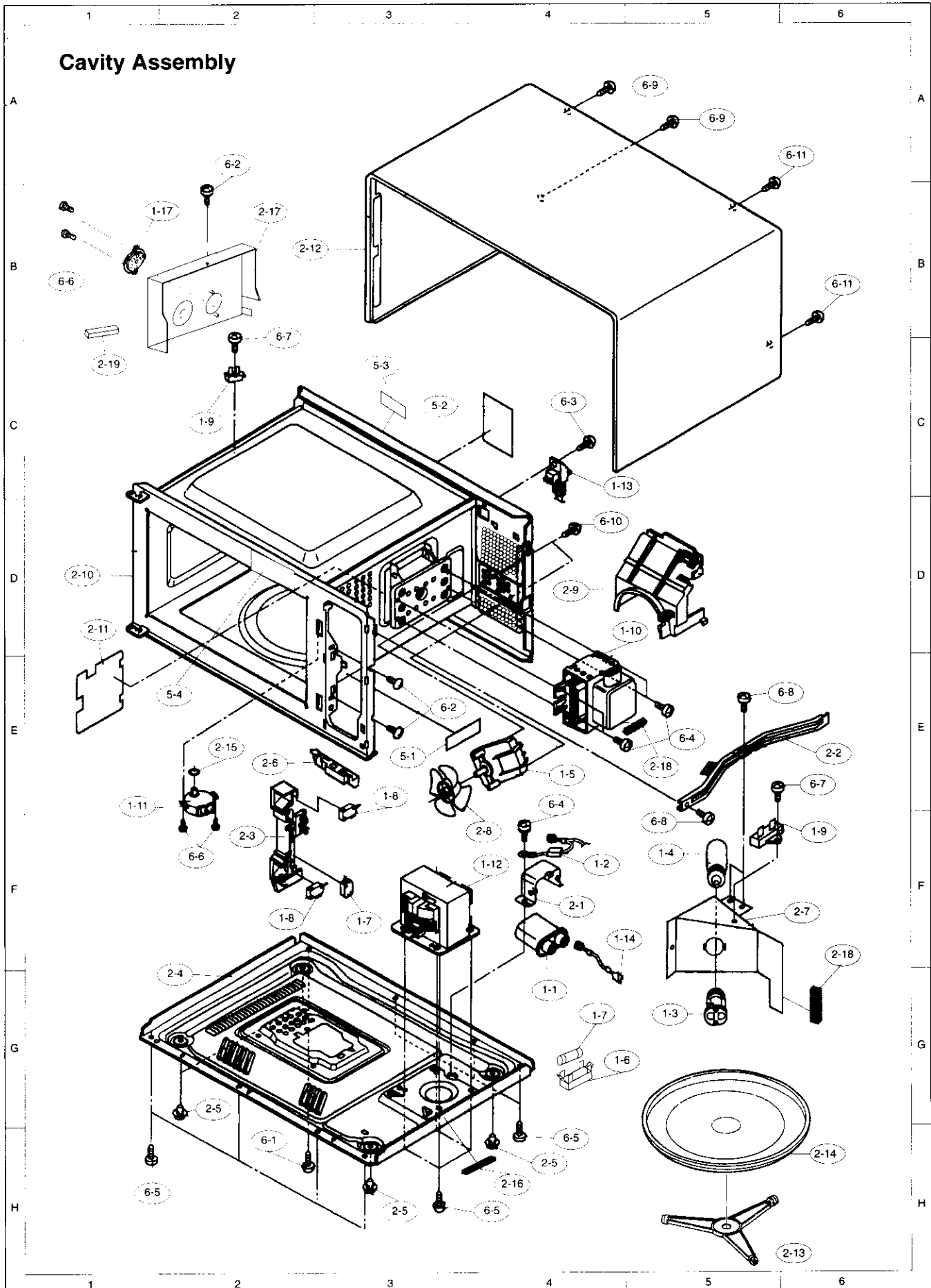

Figure 2-16
Oven Top View



Schematic Diagram

Ref No.	Part No.	§	Description	Qty	Code
Control Panel					
3-1	CPWFBF011MRU0	M	Control unit	1	BK
3-1A	QCNCMA446DRE0	J	2-pin connector (CN-A)	1	AD
3-1B	QCNCMA275DRE0	J	2-pin connector (CN-B)	1	AB
3-1C	FW-VZB146MRE0	M	Lead wire harness (WH-1)	1	AC
C1	RC-KZA087DRE0	J	Capacitor 0.1 μ F 50V	1	AB
C2	VCEAB31EW108M	J	Capacitor 1000 μ F 35V	1	AD
C3	RC-KZA087DRE0	J	Capacitor 0.1 μ F 50V	1	AB
C4-5	VCEAB31VW106M	J	Capacitor 10 μ F 35V	2	AB
D1-4	VHD11ES1///-1	J	Diode (11ES1)	4	AB
D5-8	VHD1SS270A/-1	J	Diode (1SS270A)	4	AA
Q1-Q2	VS2SB1238// -3	J	Transistor (2SB1238)	2	AA
Q3	VSKRC243M// -3	J	Transistor (KRC243M)	1	AB
R1	VRD-B12EF242J	J	Resistor 2.4k Ω ¹ / ₄ W	1	AA
R2	VRD-B12HF681J	J	Resistor 680 Ω ¹ / ₂ W	1	AA
R3	VRD-B12HF511J	J	Resistor 510 Ω ¹ / ₂ W	1	AB
R4	VRD-B12EF270J	J	Resistor 27 Ω ¹ / ₄ W	1	AA
R5	VRD-B12EF472J	J	Resistor 4.7k Ω ¹ / ₄ W	1	AA
R6	VRD-B12EF332J	J	Resistor 3.3k Ω ¹ / ₄ W	1	AA
RY2-1	RRLY-B002MRE0	M	Relay (DU24D1-1P(M))	2	AH
SP1	RALM-A014DRE0	J	Buzzer (PKM22EPT)	1	AG
T1	RTRNPB009MRE0	M	Transformer	1	AN
VRS1	RH-VZA032DRE0	J	Varistor (104G471K)	1	AE
ZD1	VHEHZ161///-1	J	Zener diode (HZ16-1)	1	AA
3-2	LHLD-B006MRF0	M	LCD holder	1	AC
3-3	FPNLCB206MRK0	M	Control panel assembly (R-430BK)	1	AX
	FPNLCB207MRK0	M	Control panel assembly (R-430BW)	1	AX
	FPNLCB208MRK0	M	Control panel assembly (R-430BD)	1	AX
3-4	FUNTKB154MRE0	M	Key unit (R-430BK)	1	AR
	FUNTKB155MRE0	M	Key unit (R-430BW)	1	AR
	FUNTKB156MRE0	M	Key unit (R-430BD)	1	AR
3-5	JBTN-B070MRF0	M	Open Button (R-430BK)	1	AE
3-5	JBTN-B071MRF0	M	Open Button (R-430BW)	1	AE
3-5	JBTN-B072MRF0	M	Open Button (R-430BD)	1	AE
3-6	MSPRTA050WRE0	M	Button Spring	1	AA
3-7	PSHEPA626WRE0	M	LED sheet	1	AR
3-8	XEPSD30P10XS0	M	Screw; Control unit mtg.	1	AA



Wire Harnesses



1-14

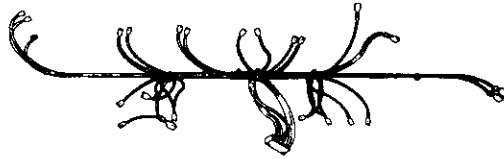

1-15

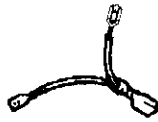

1-16

* Actual harnesses may be different than illustrations.

Packing and Accessories

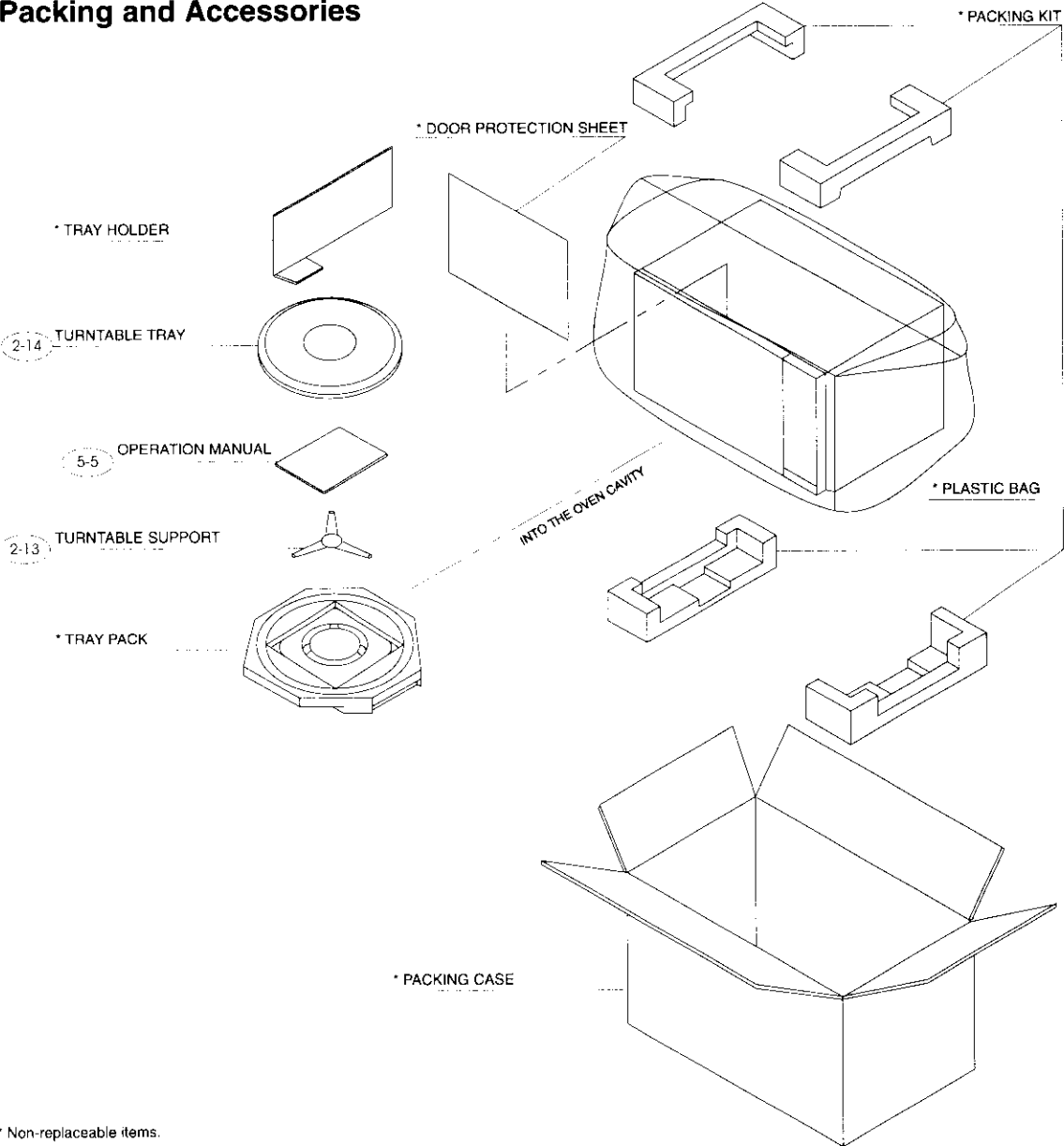

* Non-replaceable items.

R-430BK
R-430BW
R-430BD

APYDMR0114

SHARP®

Control Panel Assembly

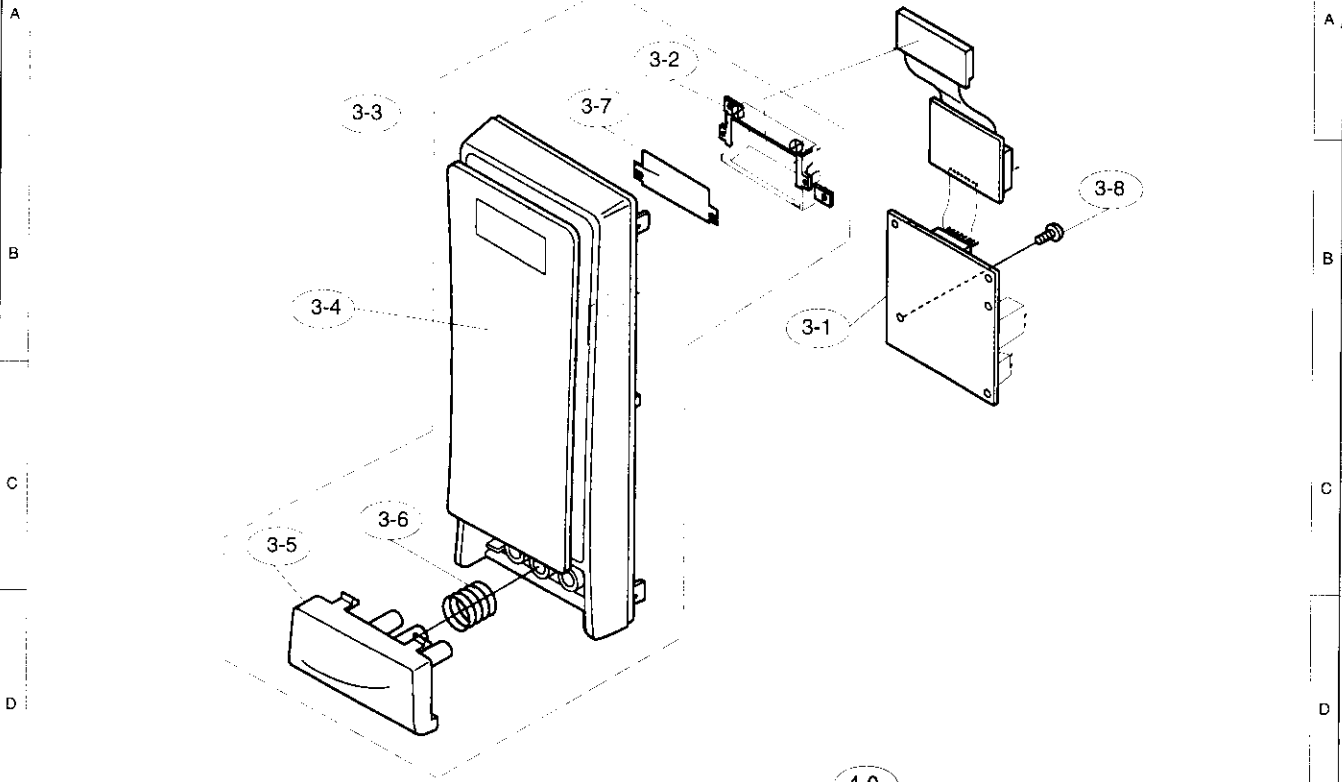

Door Assembly

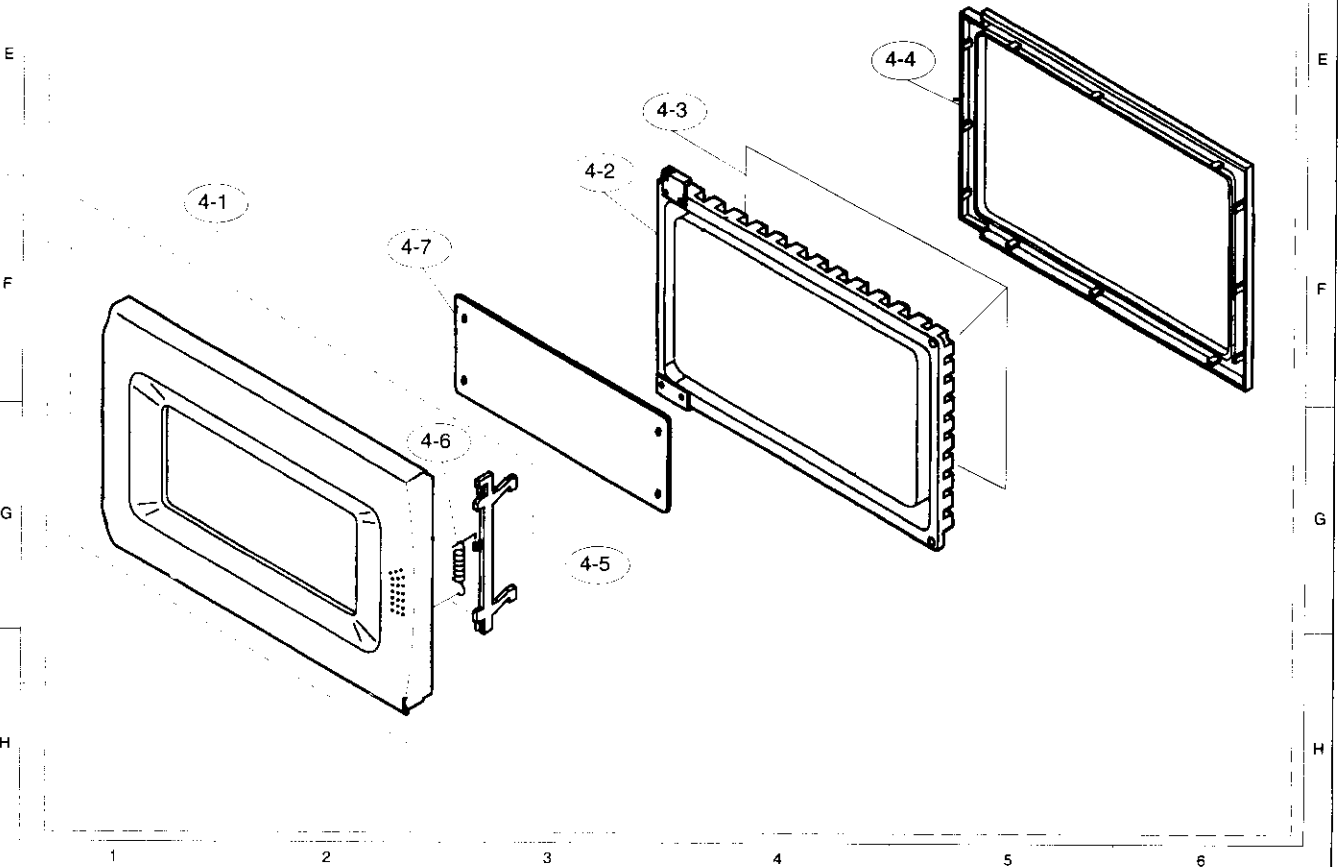

APR 2014

Ref No.	Part No.	§	Description	Qty	Code
Door					
4- 0	CDORFB217MRK0	M	Door assembly (R-430BK)	1	BE
4- 0	CDORFB216MRK0	M	Door assembly (R-430BW)	1	BE
4- 0	CDORFB215MRK0	M	Door assembly (R-430BD)	1	BE
4- 1	FCOV-B115MRK0	M	Door screen assembly (R-430BK)	1	AS
4- 1	FCOV-B116MRK0	M	Door screen assembly (R-430BW)	1	AS
4- 1	FCOV-B117MRK0	M	Door screen assembly (R-430BD)	1	AS
Δ 4- 2	FDORFB062MRT0	M	Door panel	1	AW
4- 3	PSHEPB021MRE0	M	Sealer film	1	AE
4- 4	GCOVHB034MRF0	M	Choke cover	1	AG
Δ 4- 5	LSTPPB021MRF0	M	Latch head	1	AE
4- 6	MSPRTA046WRE0	M	Latch spring	1	AB
4- 7	HPNL-B077MRE0	M	Door Screen (R-430BK)	1	AK
4- 7	HPNL-B078MRE0	M	Door Screen (R-430BW/R-430BD)	1	AK

Miscellaneous					
5- 1	TCAUAB015MRR0	M	Monitor caution label	1	AA
5- 2	TCAUAB027MRR0	M	DHHS caution label	1	AB
5- 3	TCAUAB033MRR0	M	UL SCREW label	1	AA
5- 4	TLAB-B033MRR0	M	Menu label	1	AA
5- 5	TINSEB180MRR0	M	Operation manual	1	AE

Fasteners					
6- 1	LX-BZA041WRE0	M	Screw; Base plate mtg.	3	AA
6- 2	LX-CZ0052WRE0	M	Screw; Latch hook mtg. & AH sensor duct mtg.	3	AA
6- 3	XHTSD40P12RV0	M	Screw; Power cord mtg.	1	AA
6- 4	LX-BZ0081YBE0	M	Screw; H.V. Capacitor mtg. & Magnetron mtg.	5	AA
6- 5	XOTSD40P12000	M	Screw; Power transformer mtg., Chassis support & Base plate.	12	AA
6- 6	XCPSD30P08000	M	Screw; T.T. Motor mtg. & AH sensor mtg.	4	AA
6- 7	XCBSD30P08000	M	Screw; Temperature fuse mtg.	2	AA
6- 8	XHTSD40P08000	M	Screw; Magnetron duct mtg.	2	AA
6- 9	LX-CZA038WRE0	M	Screw; O.C. Cabinet grd.	2	AA
6-10	XHTSD40P08RV0	M	Screw; Fan motor mtg.	2	AA
6-11	LX-CZB011MRE0	M	Screw; UL O.C. Cabinet	2	AA

PARTS LIST

Contact your nearest **SHARP** Parts Distributor to order.
For location of **SHARP** Parts Distributor, Please call Toll-Free;
1-800-BE-SHARP

Ref No.	Part No.	§	Description	Qty	Code
Electrical					
* 1- 1	RC-QZB018MRE0	M	H.V. Capacitor	1	AQ
* 1- 2	FH-DZB008MRY0	M	H.V. Diode assembly	1	AM
1- 3	QSOCLE006MRE0	M	Oven lamp socket	1	AE
1- 4	RLMPTA068WRE0	M	Oven lamp	1	AE
1- 5	RMOTEA346WRE0	M	Fan motor	1	AR
1- 6	QFSHDB003MRE0	M	Fuse block	1	AD
1- 7	FFS-BA016/KIT	M	Monitor switch (V-16G-2C25) & Fuse assembly (20A-250VAC)	1	AF
1- 8	QSW-MA110WRE0	M	Sec. interlock & Door sensing switch (V-16G-3C25)	2	AE
1- 9	QFS-TB006MRE0	M	Temperature fuse (144°C)	2	AF
* Δ 1-10	RV-MZA255WRE0	M	Magnetron	1	BE
1-11	RMOTDA182/KIT	M	T.T. Motor	1	AP
* 1-12	RTRN-B060MRE0	M	Power transformer	1	BF
1-13	FACCDB003MRE0	M	Power cord	1	AM
* 1-14	QW-QZB016MRE0	M	H.V. wire A (Transformer - Capacitor)	1	AC
1-15	FW-VZB147MRE0	M	Main wire harness	1	AU
1-16	FW-VZB125MRE0	M	Stop switch harness	1	AF
1-17	FDTCTA177WRK0	M	AH sensor	1	AQ
Oven					
2- 1	LBNDKB007MRP0	M	H.V. Capacitor band	1	AB
Δ 2- 2	LANGTB028MRP0	M	Chassis support	1	AF
2- 3	PHOK-B013MRF0	M	Latch hook	1	AG
2- 4	GDAI-B050MRP0	M	Base plate	1	AQ
2- 5	GLEGPB003MRF0	M	Foot	4	AA
2- 6	MLEVPB016MRF0	M	Latch lever	1	AD
2- 7	PDUC-B073MRP0	M	Magnetron duct	1	AF
2- 8	NFANPB001MRE0	M	Fan blade	1	AC
Δ 2- 9	PDUC-B043MRF0	M	Fan duct	1	AD
2-10		-	Oven cavity (Not a replaceable part)	1	-
2-11	PCOVBP037MRP0	M	Waveguide cover	1	AD
2-12	GCABUB082MRP0	M	Outer case cabinet (R-430BK)	1	AV
	GCABUB058MRP0A	M	Outer case cabinet (R-430BW)	1	AV
	GCABUB081MRP0A	M	Outer case cabinet (R-430BD)	1	AV
2-13	FROLPB024MRK0	M	T.T. Roller assembly	1	AK
2-14	NTNT-A095WRE0	M	T.T. Tray	1	AM
2-15	PPACGB014MRF0	M	T.T. Motor packing	1	AA
2-16	PCUSGB033MRP0	M	Base plate cushion	1	AA
2-17	PDUC-B074MRP0	M	AH sensor duct	1	AF
2-18	PCUSUB042MRP0	M	Air flow cushion	2	AA
2-19	PCUSGB028MRP0	M	cavity cushion	1	AA

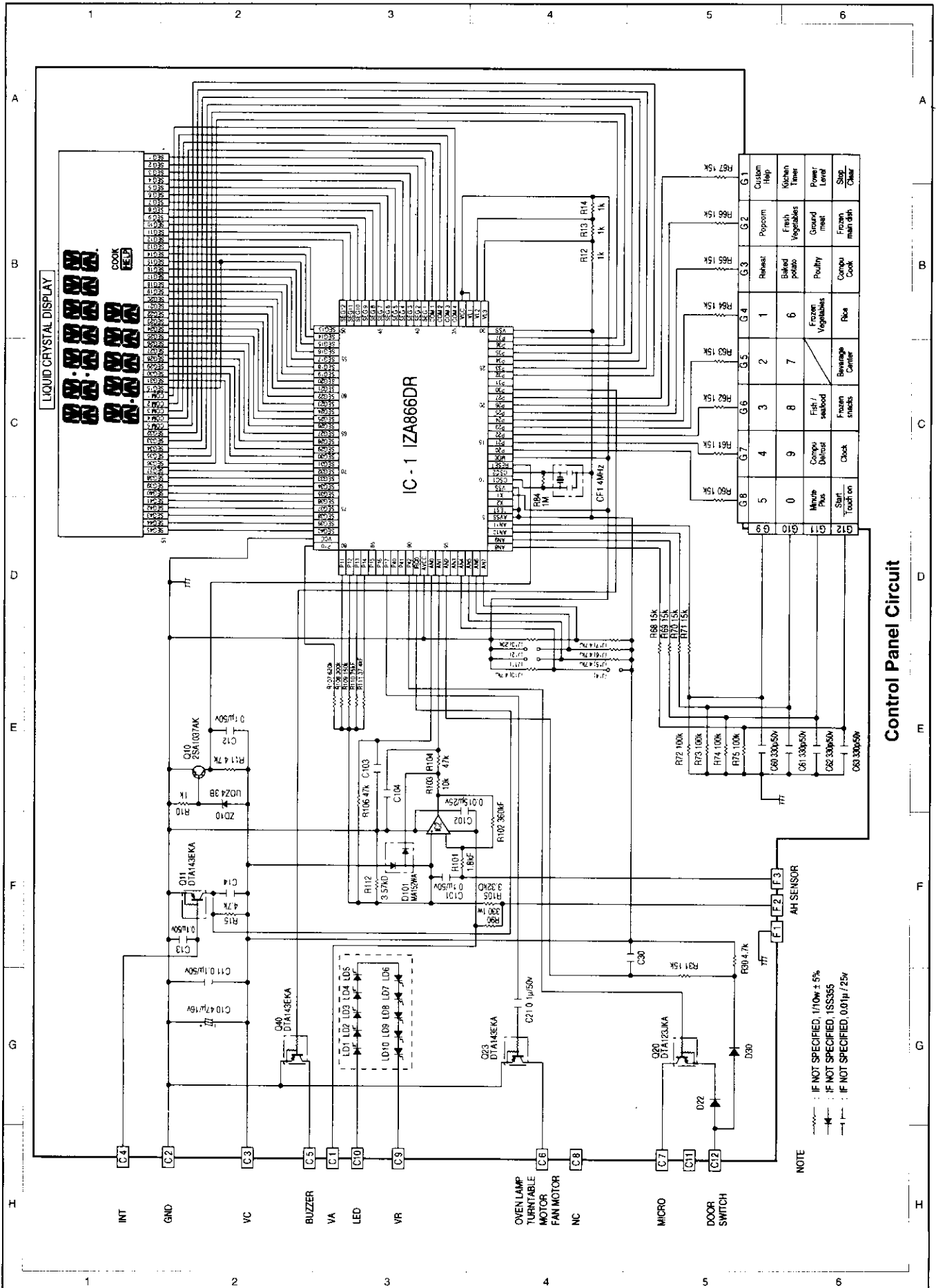

Control Panel Circuit

NOTE
 --- IF NOT SPECIFIED, 1% \pm 5%
 --- IF NOT SPECIFIED, 1SS355
 --- IF NOT SPECIFIED, 0.01 μ /25v

APYDME114

R-430BK
R-430BW
R-430BD

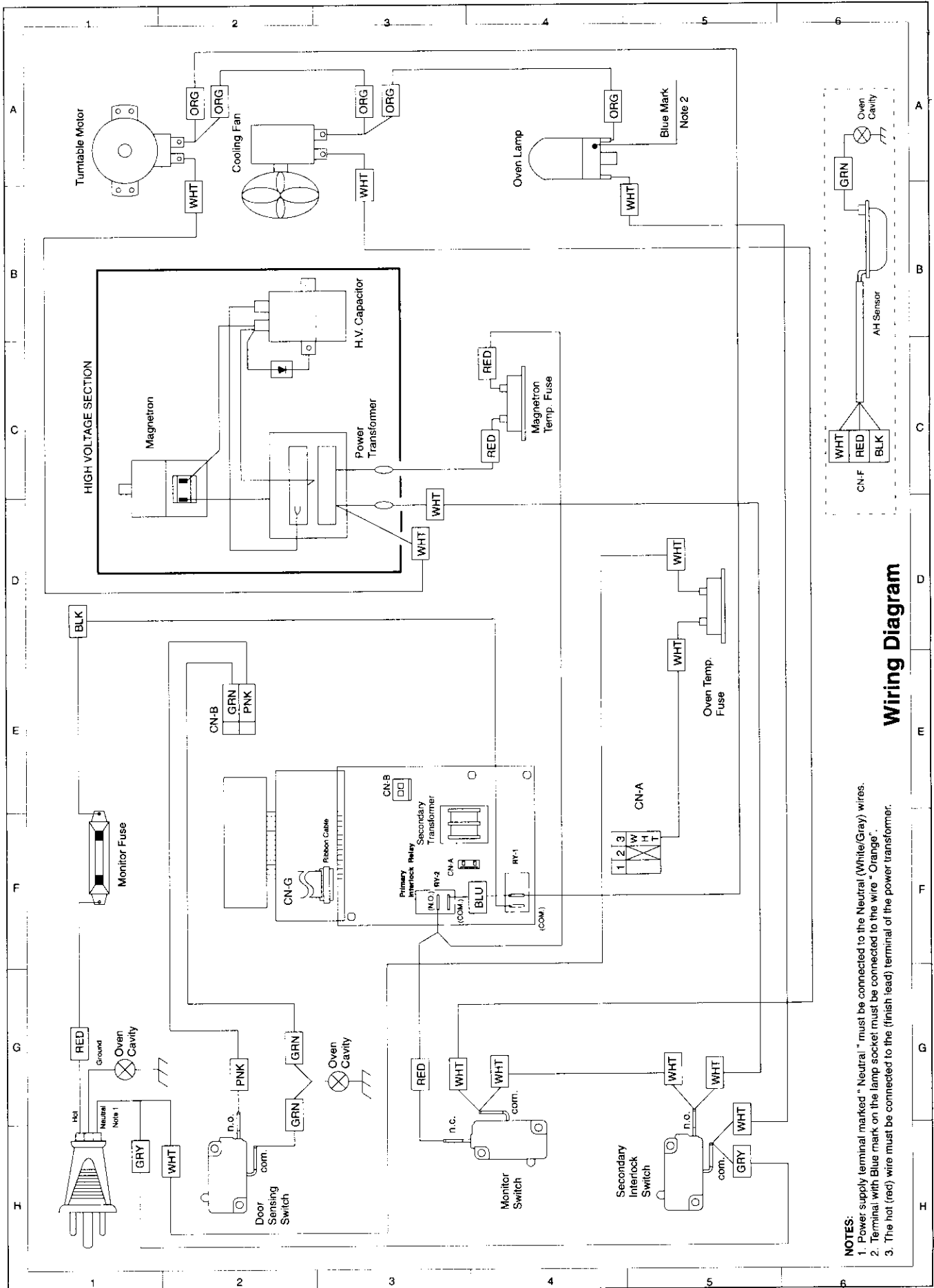

Wiring Diagram

- NOTES:**
1. Power supply terminal marked "Neutral" must be connected to the Neutral (White/Gray) wires.
 2. Terminal with Blue mark on the lamp socket must be connected to the wire "Orange".
 3. The hot (red) wire must be connected to the (finish lead) terminal of the power transformer.

MICROWAVE MEASUREMENT PROCEDURE

After adjustment of the door, interlock and monitor switches are completed individually or collectively, a INTERLOCK SWITCH TEST and MICROWAVE LEAKAGE TEST must be performed to assure compliance with DHHS (CDRH) Performance Standards for Microwave Ovens.

Interlock Switch Test

Make sure that the door sensing switch, secondary interlock switch and monitor switch are operating properly by checking with an ohmmeter.

Refer to the "Test Procedure" of the door sensing switch, secondary interlock switch and monitor switch.

Microwave Leakage Test

Requirements

1. Microwave leakage limit (Power density limit).
The power density of microwave radiation emitted by a microwave oven shall not exceed $1\text{mW}/\text{cm}^2$ at any point 5cm or more from the external surface of the oven, measured prior to acquisition by the purchaser, and thereafter (through the useful life of the oven) $5\text{mW}/\text{cm}^2$ at any point 5cm or more from the external surface of the oven.
2. Safety interlock switches.
Primary interlock relay and door sensing switch will prevent microwave radiation emissions in excess of the requirement as above mentioned, secondary interlock switch shall prevent microwave radiation emission in excess of $5\text{mW}/\text{cm}^2$ at any point 5cm or more from the external surface of the oven.

Preparation For Testing

Before beginning the actual measurement of leakage, proceed as follows:

1. Make sure that the actual instrument is operating normally as specified in its instruction booklet.

Note: Survey instruments that comply with the requirement for instrumentation 21CFR1030.10(c)(3)(i), as prescribed by the performance standard for microwave ovens must be used for testing.

2. Place the oven tray in the oven cavity.
3. Place the load of $275 \pm 15\text{ml}$ (9.8 oz.) of tap water initially at $20 \pm 5^\circ\text{C}$ (68°F) in the center of the oven cavity.
The water container shall be a low form of 600 ml (20 oz.) beaker with an inside diameter of approximately 8.5 cm ($3\frac{1}{2}$ in.) and made of an electrically nonconductive material such as glass or plastic.
The placing of this standard load in the oven is important not only to protect the oven, but also to insure that any leakage is measured accurately.
4. Set the cooking control on High.
5. Close the door and put the oven into a cook cycle for several minutes. If the water begins to boil before the survey is completed, replace it with 275ml of cool water.

Leakage Test

Closed-door leakage test (microwave measurement).

1. Grasp the probe of the survey instrument and hold it perpendicular to the gap between the door and the body of the oven.
2. Move the probe slowly, not faster than 1in./sec ($2.5\text{cm}/\text{sec.}$) along the gap, watching for the maximum indication of the meter.
3. Check for leakage at the door screen, sheet metal seams and other accessible positions where the continuity of the metal has been breached (eg., around switches, indicator and vents).
While testing for leakage around the door pull the door away from the front of the oven as far as is permitted by the closed latch assembly.
4. Measure carefully at the point of the highest leakage and make sure that the highest leakage is no greater than $4\text{mW}/\text{cm}^2$ to allow for measurement uncertainty, and that the secondary interlock switch does turn the oven OFF before any door movement.

Note: After servicing, record data on service invoice and microwave leakage report.

AH SENSOR DUCT REMOVAL

1. Disconnect the power supply cord.
2. Open the oven door and block it open.
3. Remove screws from the rear of the outercase cabinet. Slide the entire case back about 1 inch (3cm) to free it from retaining clips on the cavity faceplate.
4. Discharge the high voltage capacitor.
5. Lift entire outer case cabinet from unit.
6. Remove ground screw mounted into the sensor duct.
7. Slide the two tabs of the sensor duct to the right.
8. Sensor duct is now free.

CAUTION !

Discharge the high voltage capacitor before touching any oven components or wiring.

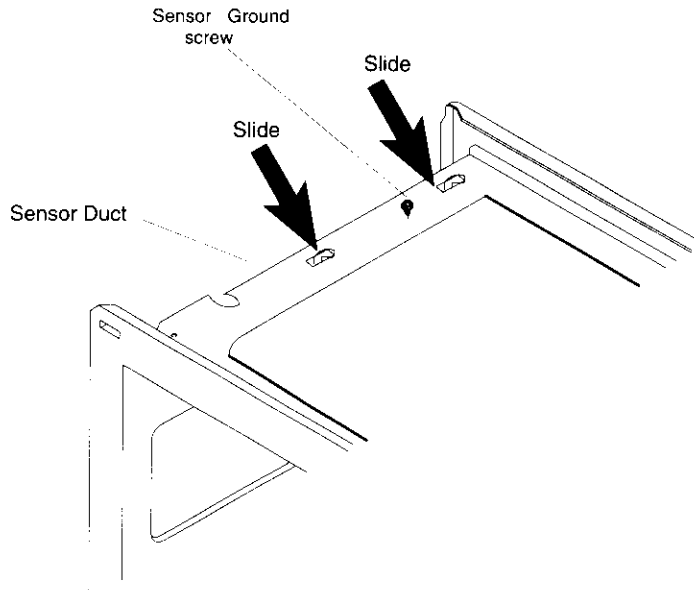

AH SENSOR REPLACEMENT

Removal

1. Disconnect power supply cord .
2. Open the oven door and block it open.
3. Remove screws from the rear of the outercase cabinet. Slide the entire case back about 1 inch (3cm) to free it from retaining clips on the cavity faceplate.
4. Lift the entire outercase cabinet from the oven unit.
5. Discharge high voltage capacitor.
6. Remove two (2) screws holding the AH sensor Refer to Figures 1-16 & 2-16.
7. Disconnect the AH sensor harness from connector CN-F on control unit.
8. AH sensor is now free.

Installation

1. Insert new AH sensor into AH sensor duct. Refer to Figures 1-16 & 2-16 for proper sensor orientation.
2. Install two (2) screws to secure AH sensor.
3. Route the AH sensor harness above emboss on AH sensor duct. Refer to Figures 1-16 & 2-16.
4. Continue to route AH sensor harness across the oven cavity top plate and through the large opening. Refer to Figure 2-16.
5. Connect AH sensor harness to CN-F on the control unit.
6. Re-install the outercase cabinet and check for proper operation.

COMPONENT REPLACEMENT/ADJUSTMENT PROCEDURE**WARNING AGAINST HIGH VOLTAGE**

Microwave ovens contain circuitry capable of producing very high voltage and current, contact with the following parts may result in severe, possibly fatal, electric shock.

Example

High Voltage Capacitor, Power Transformer, Magnetron, High Voltage Rectifier Assembly, High Voltage Harness etc..

WARNING

Avoid possible exposure to microwave energy. Please follow the instructions below before operating the oven.

1. Disconnect the power supply cord.
 2. Visually check the door and cavity face plate for damage (dents, cracks, signs of arcing etc.).
- Carry out any remedial work that is necessary before operating the oven.

Do not operate the oven if any of the following conditions exist;

1. Door does not close firmly.
2. Door hinge, support or latch hook is damaged.
3. The door gasket or seal is damaged.
4. The door is bent or warped.

5. There are defective parts in the door interlock system.
6. There are defective parts in the microwave generating and transmission assembly.
7. There is visible damage to the oven.

Do not operate the oven:

1. Without the RF gasket (Magnetron).
2. If the wave guide or oven cavity are not intact.
3. If the door is not closed.
4. If the outer case cabinet is not fitted.

WARNING FOR WIRING

To prevent electric shock, take the following precautions.

1. Before wiring.
 - 1) Disconnect the power supply cord.
 - 2) Open the door and block it open.
 - 3) Discharge the high voltage capacitor and wait for 60 seconds.
2. Don't let the wire leads touch the following parts;
 - 1) High voltage parts:
Magnetron, High voltage Transformer, High voltage capacitor and High voltage rectifier assembly.
 - 2) Hot parts:
Oven lamp, Magnetron, High voltage Transform-

er and oven cavity.

- 3) Sharp edge:
Bottom plate, oven cavity, waveguide, flange, chassis support and other metallic plate.
- 4) Movable parts (to prevent a fault)
Fan blade, Fan motor, Switch, Switch lever, and Open button.
3. Do not catch the wire leads in the outer case cabinet.
4. Insert the positive lock connector until its pin is locked and make sure that the wire leads do not come off even if the wire leads are pulled.
5. To prevent an error function, connect the wire leads correctly, referring to the Wiring Diagram.

APPENDIX 114

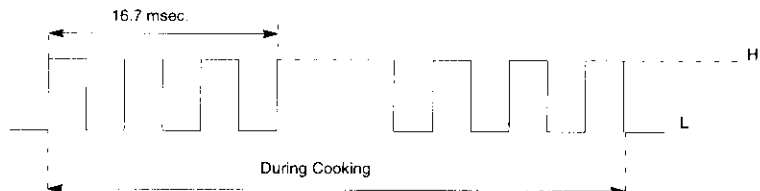
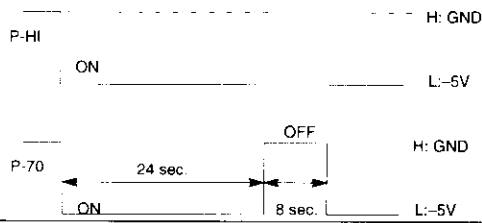
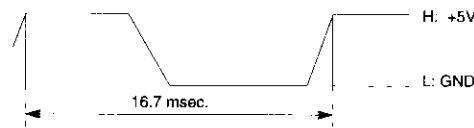
Pin No.	Signal	I/O	Description
80-84	P10-P14	OUT	Used for Initial balancing of the bridge circuit (absolute humidity sensor).
85-86	P15-P16	OUT	Terminal not used.
87	P17	OUT	<p>Oven lamp, fan motor and turntable motor driving signal. To turn on and off shut off relay RY1. The square waveform voltage is delivered to the RY-1 driving circuit and RY-2 control circuit.</p> 
88-89	P40-P41	OUT	Terminal not used.
90	P42	OUT	<p>Magnetron high-voltage circuit driving signal. To turn on and off cook relay RY2. In high operation, the signals holds "H" level during microwave cooking and "L" level while not cooking. In other cooking modes (variable cooking) the signal turns to "H" level and "L" level in repetition according to the power level.</p> 
91	IRQ0	IN	<p>Signal synchronized with commercial power source frequency. This is the basic timing for time processing of LSI.</p> 
92	AVCC	IN	<p>A/D converter power source voltage. The power source voltage to drive the A/D converter in the LSI. Connected to GND.</p>
93	AN0	IN	Used for Initial balancing of the bridge circuit (absolute humidity sensor). This input is an analog input terminal from the AH sensor circuit, and connected to the A/D converter built into the LSI.
94	AN1	IN	<p>AH Sensor input. This is an analog input terminal from the AH sensor circuit and is connected to the A/D converter built in to the LSI.</p>
95	AN2	IN	<p>To Input signal which communicates the door open/close information to the LSI. Door closed; "H" level signal (0V). Door opened "L" level signal (-5V).</p>
96	AN3	OUT	Terminal not used.
97-100	AN4-AN7	IN	<p>Terminal to change functions according to the Model. By using the A/D converter contained in the LSI, DC voltage in accordance with the Model in operation is applied to set up its cooking constant.</p>

DESCRIPTION OF LSI

The I/O signals of the LSI (IZA866DR) is detailed in the following table.

Pin No.	Signal	I/O	Description
1	AN8	IN	Signal coming from touch-key. When either G-12 line on key matrix is touched, a corresponding signal out of P20-P27 will be input into AN8. When no key is touched, the signal is held at "H" level.
2	AN9	IN	Signal similar to AN8. When either G11 line on key matrix is touched, a corresponding signal will be inputted into AN9.
3	AN10	IN	Signal similar to AN8. When either G10 line on key matrix is touched, a corresponding signal will be inputted into AN10.
4	AN11	IN	Signal similar to AN8. When either G9 line on key matrix is touched, a corresponding signal will be inputted into AN11.
5	AVSS	IN	A/D converter power source voltage. The power source voltage to drive the A/D converter in the LSI. Connected to VC.
6	TEST	IN	Connected to VC.
7	X2	OUT	Terminal not used.
8	X2	IN	Connected to GND.
9	VSS	IN	Power source voltage: - 5V. VC voltage of power source voltage to drive the LSI is input to VSS terminal. Connected to VC.
10	OSC1	IN	Internal clock oscillation frequency setting input. The internal clock frequency is set by applying the ceramic filter oscillator circuit with respect to OSC1 terminal.
11	OSC2	OUT	Internal clock oscillation frequency control output. Output to control oscillation input of OSC2.
12	RESET	IN	Auto-clear terminal. Signal is input to reset the LSI to the initial state when power is supplied. Temporarily set to "L" level the moment power is supplied, at this time the LSI is reset. Thereafter set at "H" level.
13	MD0	IN	Connected to GND.
14	P20	OUT	Key strobe signal. Signal applied to touch-key section. A pulse signal is inputted to AN8 - AN11 terminal while one of G8 line keys on key matrix is touched.
15	P21	OUT	Key strobe signal. Signal applied to touch-key section. A pulse signal is inputted to AN8 - AN11 terminal while one of G7 line keys on key matrix is touched.
16	P22	OUT	Key strobe signal. Signal applied to touch-key section. A pulse signal is inputted to AN8 - AN11 terminal while one of G6 line keys on key matrix is touched.
17	P23	OUT	Key strobe signal. Signal applied to touch-key section. A pulse signal is inputted to AN8 - AN11 terminal while one of G5 line keys on key matrix is touched.
18	P24	OUT	Key strobe signal. Signal applied to touch-key section. A pulse signal is inputted to AN8 - AN11 terminal while one of G4 line keys on key matrix is touched.
19	P25	OUT	Key strobe signal. Signal applied to touch-key section. A pulse signal is inputted to AN8 - AN11 terminal while one of G3 line keys on key matrix is touched.
20	P26	OUT	Key strobe signal. Signal applied to touch-key section. A pulse signal is inputted to AN8 - AN11 terminal while one of G2 line keys on key matrix is touched.
21	P27	OUT	Key strobe signal. Signal applied to touch-key section. A pulse signal is inputted to AN8 - AN11 terminal while one of G1 line keys on key matrix is touched.

TEST PROCEDURES

Procedure Letter

Component Test

L. Checking the Control Unit (*Continued*)

6. Disconnect the wire leads to the primary of power transformer.
7. Ensure that these leads remain isolated from other components and oven chassis by using insulated tape.
8. After that procedure, re-connect the power supply cord.
9. Check the sensor cook operation proceed as follows:
 - A. Touch REHEAT pad once and touch Start pad.
 - B. The control panel is in the sensor cooking operation.
 - C. After approximately 20 seconds, push plunger of select switch for more than 3 seconds. This condition is the same as judgment by AH sensor.
 - D. After approximately 3 seconds, the display shows "XX. XX" which is the remaining cooking time, and the display counts down.

If the above is not the case, the control unit is probably defective.

If the above checks positive, the AH sensor is probably defective.

10. Disconnect the power supply cord, and then remove outer case cabinet.
11. Open the door and block it open.
12. Discharge the high voltage capacitor.
13. Disconnect the dummy resistor circuit from the sensor connector of control panel.
14. Carry out the necessary repair.
15. Reconnect all leads removed from components during testing and repairing.
16. Re-install the outer case cabinet.
17. Reconnect the power supply cord after the outer case is installed. Run the oven and check all functions.
18. Carry out the "Water load cooking test" again and ensure that the oven works properly.

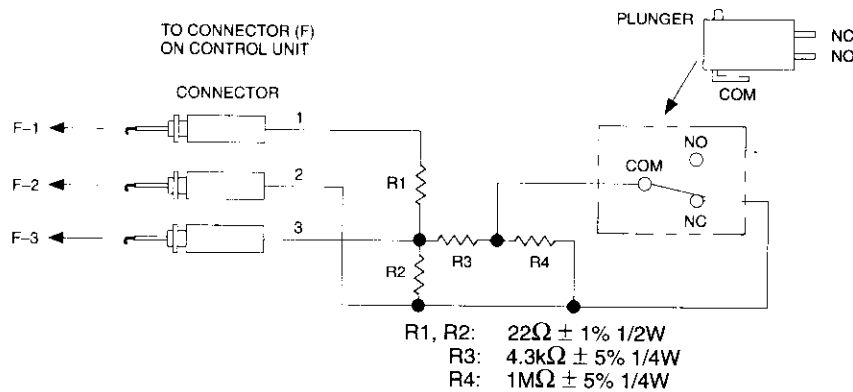

Figure A. Sensor Dummy Resistor Circuit

APPYDMR0114

TEST PROCEDURES

Procedure Letter

Component Test

J Compu Defrost Test

1. Place one cup of water in the center of the turntable tray in the oven cavity.
2. Close the door, touch the "COMPU DEFROST" pad once and touch the number pad "1", and touch the number pad "5". Then touch the "START" pad.
3. The oven is in "COMPU DEFROST" cooking mode.
4. The oven will operate as follows:

Weight	1st Stage		2nd Stage		3rd Stage		4th Stage	
	Level	Time	Level	Time	Level	Time	Level	Time
0.5	70%	47 sec.	0%	52 sec.	50%	32 sec.	30%	40 sec.

5. If improper operation is indicated, the control unit is probably defective and should be checked.

K. Key Unit Test

1. Disconnect the power supply cord, and then remove outer case cabinet.
2. Open the door and block it open.
3. Discharge the high voltage capacitor.
4. If the display fails to clear when the STOP/CLEAR pad is depressed, first verify the flat ribbon is making good contact and verify that the door sensing switch operates properly (contacts are closed when the door is closed and open when the door is open). If the door sensing switch is good, disconnect the flat ribbon cable that connects the key unit to the control unit and make sure the door sensing switch is closed (either close the door or short the door sensing switch connector). Use the key unit matrix indicated on the control panel schematic and place a jumper wire between the pins that correspond to the STOP/CLEAR pad making momentary contact. If the control unit responds by clearing with a beep the key unit is faulty and must be replaced. If the control unit does not respond, it is faulty and must be replaced. If a specific pad does not respond, the above method may be used (after clearing the control unit) to determine if the control unit or pad is at fault.
5. Reconnect all leads removed from components during testing.
6. Re-install the outer case cabinet.
7. Reconnect the power supply cord after installing the outer case cabinet
8. Run the oven and check all functions.

	G8	G7	G6	G5	G4	G3	G2	G1
G9	5	4	3	2	1	Reheat	Popcorn	Custom Help
G10	0	9	8	7	6	Baked potato	Fresh vegetables	KITCHEN TIMER
G11	Minute Plus	Compu Defrost	Fish/seafood	/	Frozen vegetables	Poultry	Ground meat	POWER LEVEL
G12	Start Touch on	Clock	Frozen snacks		Beverage center	Rice	Compu Cook	Frozen main dish

KEY UNIT

TEST PROCEDURES

Procedure Letter	Component Test
------------------	----------------

G. Touch Control Panel Assembly Test (Continued)

When testing is completed,

1. Disconnect the power supply cord, and then remove outer case cabinet.
2. Open the door and block it open.
3. Discharge the high voltage capacitor.
4. Reconnect all leads removed from components during testing.
5. Re-install the outercase cabinet.
6. Reconnect the power supply cord after installing the outer case cabinet.
7. Run the oven and check all functions.

H. Relay Test

1. Disconnect the power supply cord, and then remove outer case cabinet.
2. Open the door and block it open.
3. Discharge the high voltage capacitor.
4. Disconnect the leads to the primary of the power transformer.
5. Ensure that the leads remain isolated from other components and oven chassis by using insulated tape.
6. After the above procedure , reconnect the power supply cord.
7. Check voltage between Pin No. 1 of the 2 pin connector (A) and the common terminal of the relay RY1 on the control unit with A.C. voltmeter. The meter should indicate 120volts. If not, check oven circuit.

RY-1 and RY-2 Relay Test

These relays are operated by D.C. voltage.

Check voltage at the relay coil with a D.C. voltmeter during the microwave cooking operation.

DC. voltage indicated Defective relay.

DC. voltage not indicated Check diode which is connected to the relay coil. If diode is good, control unit is defective.

Relay Symbol	Operational Voltage	Connected Components
RY 1	Approx. 24.3 V DC	Oven lamp/Turntable motor/Cooling fan motor
RY 2	Approx. 23.5 V DC	Power transformer

8. Disconnect the power supply cord.
9. Open the door and block it open.
10. Discharge the high voltage capacitor.
11. Reconnect all leads removed from components during testing.
12. Re-install the outer case cabinet.
13. Reconnect the power supply cord after installing the outer case cabinet.
14. Run the oven and check all functions.

I. Foil pattern on the printed wiring board Test

To protect the electronic circuits, this model is provided with a fine foil pattern added to the primary on the PWB, which acts as a fuse.

1 Foil Pattern check and repairs

1. Disconnect the power supply cord, and then remove outer case cabinet.
2. Open the door and block it open.
3. Discharge the high voltage capacitor.
4. Follow the troubleshooting guide given below for repair.

Steps	Occurrence	Cause or Correction
1	Only pattern at "a" is broken.	* Insert jumper wire J1 and solder.
2	Pattern at "a" and "b" are broken	* Insert the coil RCILF2003YAZZ between "c" and "d".

APPYDMK0114

SERVICING

When troubleshooting the microwave oven, it is helpful to follow the sequence of operation in performing the checks. Many of the possible causes of trouble will require that a specific test be performed. These tests are given a procedure letter which will be found in the "Test Procedure" section.

IMPORTANT !

Before replacing a blown monitor fuse, test the door sensing switch, primary interlock relay, secondary interlock switch and monitor switch for proper operation. (Refer to "Test Procedure" section.)

IMPORTANT !

Whenever troubleshooting is performed, the power supply must be disconnected. In some cases it may be necessary to connect the power supply after the outer case cabinet has been removed. In this event,

1. Disconnect the power supply cord, and then remove outer case cabinet.
2. Open the door and block it open.
3. Discharge the high voltage capacitor.
4. Disconnect the leads to the primary of the power transformer.
5. Ensure that the leads remain isolated from other components and oven chassis by using insulated tape.
6. After the above procedure install the outer case cabinet, reconnect the power supply cord.

When the testing is completed

1. Disconnect the power supply cord, and then remove outer case
2. Open the door and block it open.
3. Discharge the high voltage capacitor.
4. Reconnect the leads to the primary of the power transformer.
5. Re-install the outer case (cabinet).
6. Reconnect the power supply cord after the outer case is installed.
7. Run the oven and check all functions.

Troubleshooting Guide

Sensor Cooking Condition		
Problem	Possible Cause	Test Procedure
The oven is in the sensor cooking condition but AH sensor does not end or AH sensor turns off about a maximum of 30 minutes after start. When a cup of water is heated by sensor, the oven does not shut off when the water is boiling.	Control Unit	Procedure G
	AH Sensor	Procedure L

Key Unit Layout

- a. Indicators.
- b. Lighted digital display.
- c. Custom Help.
Features user friendly communications during cooking procedure.
- d. SENSOR COOKING pads.
Cooking time is determined by AH Sensor
- e. Minute Plus pad.
Touch to start oven or Touch to cook for 1 minute at 100% power or to increase cooking time.
- f. Compu Cook pad.
Touch to cook certain foods.
- g. Compu Defrost pad.
Touch to defrost certain foods.
- h. Number selection pads.
- i. Power Level pad. Touch to select microwave power setting.
- j. Clock pad.
Touch to set clock.
- k. Beverage Center pad.
Touch to Reheat certain beverages.
- l. Stop/Clear pad.
Touch to erase during programming.
Touch once to stop operation of oven during cooking.
Touch twice to cancel cooking program.
- m. Kitchen Timer pad.
Touch to set minute function.
- n. Start/Touch On pad.
Touch to start oven.

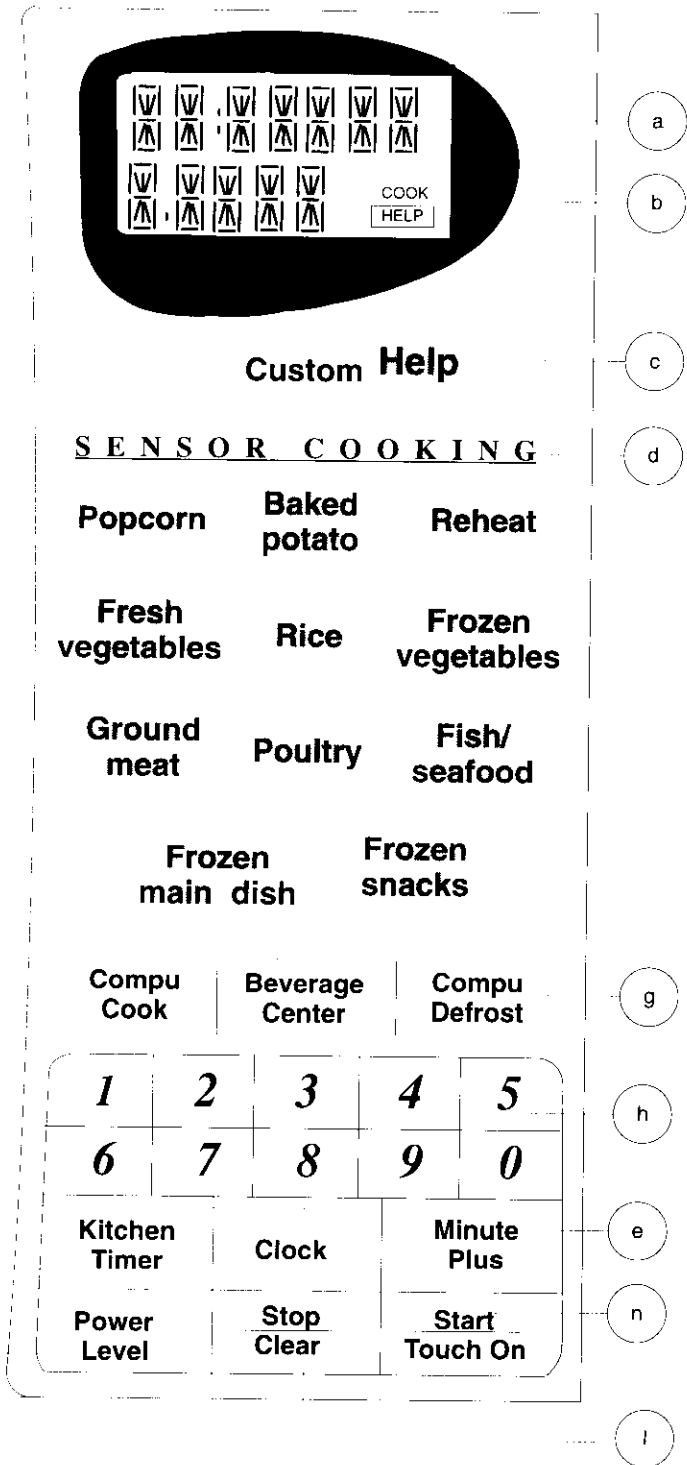

▽	▽	▽	▽	▽	▽	▽
△	△	△	△	△	△	△
▽	▽	▽	▽	▽	COOK HELP	
△	△	△	△	△		

Custom Help

SENSOR COOKING

Popcorn	Baked potato	Reheat
Fresh vegetables	Rice	Frozen vegetables
Ground meat	Poultry	Fish/seafood
Frozen main dish	Frozen snacks	

Compu Cook	Beverage Center	Compu Defrost
------------	-----------------	---------------

1	2	3	4	5
6	7	8	9	0

Kitchen Timer	Clock	Minute Plus
Power Level	Stop Clear	Start Touch On

WARNING TO SERVICE PERSONNEL

Microwave ovens contain circuitry capable of producing very high voltage and current. Contact with following parts may result in a severe, possibly fatal, electrical shock.

(EXAMPLE)

High Voltage Capacitor, High Voltage Power Transformer, Magnetron, High Voltage Rectifier Assembly, High Voltage Harness etc..

Read the Service Manual carefully and follow all instructions.

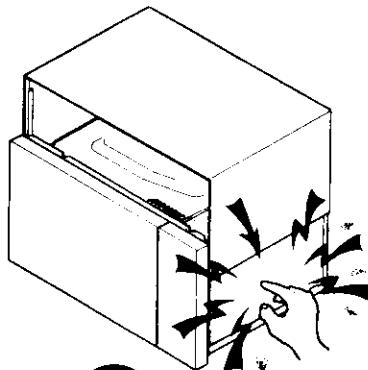

**Don't Touch !
Danger High Voltage**

Before Servicing

1. Disconnect the power supply cord and then remove outer case
2. Open the door and block it open.
3. Discharge the high voltage capacitor.

WARNING: RISK OF ELECTRICAL SHOCK. DISCHARGE THE HIGH VOLTAGE CAPACITOR BEFORE SERVICING.

The high-voltage capacitor remains charged about 60 seconds after the oven has been switched off. Wait for 60 seconds and then short-circuit the connection of the high voltage capacitor (that is the connecting lead of the high voltage rectifier) against the chassis with the use of an insulated screwdriver.

Whenever troubleshooting is performed, the power supply must be disconnected. In some cases it may be necessary to connect the power supply after the outer case has been removed, in this event:

1. Disconnect the power supply cord, and then remove outer case cabinet.
2. Open the door and block it open.
3. Discharge the high voltage capacitor.
4. Disconnect the leads to the primary of the power transformer.
5. Ensure that the leads remain isolated from other components and oven chassis by using insulation tape.
6. After the above procedure, reconnect the power supply cord.

When the testing is completed

1. Disconnect the power supply cord and then remove outer case cabinet.
2. Open the door and block it open.
3. Discharge the high voltage capacitor.
4. Reconnect the leads to the primary of the power transformer.
5. Re-install the outer case cabinet.
6. Reconnect the power supply cord after the outer case cabinet is installed.
7. Start the oven and check all functions.

After repairing

1. Reconnect all leads removed from components during testing.
2. Re-install the outer case (cabinet).
3. Reconnect the power supply cord after the outer case is installed.
4. Reconnect the power supply cord after the outer case is installed.
5. Run the oven and check all functions.

Microwave ovens should not be operated empty. To test for the presence of microwave energy within a cavity, place a cup of cold water on the oven turntable, close the door and set the power to HIGH and set the microwave timer for two (2) minutes. When the two minutes has elapsed (timer at zero), carefully check to see if the water is hot. If the water remains cold, carry out **Before Servicing** procedure and re-examine the connection to the component being tested.

When all service work is completed and the oven is fully assembled, the microwave power output should be checked and the microwave leakage test should be carried out.

PRECAUTIONS TO BE OBSERVED BEFORE AND DURING SERVICING TO AVOID POSSIBLE EXPOSURE TO EXCESSIVE MICROWAVE ENERGY

- (a) Do not operate or allow the oven to be operated with the door open.
- (b) Make the following safety checks on all ovens to be serviced before activating the magnetron or other microwave source, and make repairs as necessary: (1) Interlock operation, (2) proper door closing, (3) seal and sealing surfaces (arcing, wear, and other damage), (4) damage to or loosening of hinges and latches, (5) evidence of dropping or abuse.
- (c) Before turning on microwave power for any service test or inspection within the microwave generating compartments, check the magnetron, waveguide or transmission line, and cavity for proper alignment, integrity, and connections.
- (d) Any defective or misadjusted components in the interlock, monitor, door seal, and microwave generation and transmission systems shall be repaired, replaced, or adjusted by procedures described in this manual before the oven is released to the owner.
- (e) A microwave leakage check to verify compliance with the Federal Performance Standard should be performed on each oven prior to releasing the oven to the owner.

(RD21101U)

BEFORE SERVICING

Before servicing an operative unit, perform a microwave emission check as per the Microwave Measurement Procedure outlined in this service manual. If microwave emissions level is in excess of the specified limit, contact SHARP ELECTRONICS CORPORATION immediately @ 1-800-237-4277.

If the unit operates with the door open, service person should 1) tell the user not to operate the oven and 2) contact SHARP ELECTRONICS CORPORATION and DHHS immediately.

Service personnel should inform SHARP ELECTRONICS CORPORATION of any certified unit found with emissions in excess of $4\text{mW}/\text{cm}^2$. The owner of the unit should be instructed not to use the unit until the oven has been brought into compliance.

(RD81001U)