









## Precautions (ALWAYS FOLLOW THESE DIRECTIONS)

- Before use, read these “Precautions” carefully and use your FOMA properly. Keep this manual in a safe place for future reference.
- These precautions contain information intended to prevent bodily injury to the user and to surrounding people, as well as damage to property, and must be observed at all times.

The following symbols indicate the different degrees of injury or damage that may occur if information provided is not observed and the FOMA terminal is used improperly.

 <b>Danger</b>	This symbol indicates that “death or serious bodily injury may directly and immediately result from improper use”.
 <b>Warning</b>	This symbol indicates that “death or serious bodily injury may result from improper use”.
 <b>Caution</b>	This symbol indicates that “bodily injury and/or property damage may result from improper use”.

The following symbols indicate specific directions.

	Indicates a prohibited action.
Don't	
	Indicates not to disassemble the device.
No disassembly	
	Indicates not to handle the device with wet hands.
No wet hands	
	Indicates not to use the device near water or get it wet.
No liquids	
	Indicates that instructions specified are compulsory (must be followed).
Instruction	
	Indicates that the power cord must be unplugged from the outlet.
Unplug	

“Precautions” is explained in the following six sections.

- Handling the FOMA terminal, battery pack, adapters, and FOMA card (general) . . . . . P. 11
- Handling the FOMA terminal . . . . . P. 12
- Handling battery pack . . . . . P. 15
- Handling adapters . . . . . P. 16
- Handling FOMA card . . . . . P. 17
- Handling mobile phones near electronic medical equipment . . . . . P. 17

## Handling the FOMA terminal, battery pack, adapters, and FOMA card (general)

### Danger



Don't

**Do not use, store, or leave the FOMA terminal, battery pack, adapters or FOMA card in locations subject to high temperatures, such as near a fire, in direct sunlight, or inside a car on a hot day.**

The FOMA terminal may become deformed or malfunction. In addition, the battery pack may leak, overheat, explode, catch fire or suffer performance loss and a reduced service life. Part of the casing may also become hot and cause burns.



No disassembly

**Do not attempt to disassemble or modify. In addition, do not attempt to solder.**

May cause accidents such as fire, bodily injury, electric shock or malfunction. In addition, the battery pack may leak, overheat, explode or catch fire.



No liquids

**Do not get the FOMA terminal, battery pack, adapters or FOMA card wet.**

Contact with water, pet urine, and other liquids may cause overheating, electric shock, fire, malfunction or bodily injury. Be attentive to where and how you use the handset.



Instruction

**Use only the battery packs and adapters specified by NTT DOCOMO for use with the FOMA terminal.**

The use of devices other than those specified may cause the FOMA terminal, battery pack or other devices to leak, overheat, explode, catch fire or malfunction.

### Warning



Don't

**Do not place the battery pack, FOMA terminal, adapters, or FOMA card inside cooking appliances such as microwave ovens or pressure cookers.**

The battery pack may leak, overheat, explode or catch fire, and the FOMA terminal and adapters may overheat, emit smoke or catch fire. The internal circuitry may also be damaged.



Don't

**Do not subject the FOMA terminal to strong impacts or throw it.**

The battery pack may leak, overheat, explode or catch fire. Other devices may also be damaged or cause a fire.



Don't

**Do not allow conductive materials (such as metal objects and pencil lead) to come into contact with the charger terminal or external device terminal. In addition, do not insert such objects.**

The battery pack may short-circuit and cause a fire or malfunction.



Instruction

**Make sure to turn off the mobile phone in locations such as gas stations where flammable gas is generated. In addition, do not charge the battery. It may cause a gas explosion or fire.**

To use Osaifu-Keitai in locations such as gas stations, make sure to turn off the power in advance (If the IC card lock is set, disable the lock before turning off the power).



Instruction

**If you notice anything unusual, such as an unusual odor, overheating, discoloration or deformation during use, charging or storage, immediately follow the instructions below.**

- 1. Unplug the power cord from the outlet or cigarette lighter socket.**
- 2. Turn off the FOMA terminal.**
- 3. Remove the battery pack from the FOMA terminal.**

Continued use (charging) may cause overheating, explosion, or fire. In addition, the battery pack may leak.

## Caution



Don't

**Do not leave the FOMA terminal on unstable surfaces, such as on a wobbling table or sloped surface.**

The FOMA terminal may fall and cause injury or be damaged.



Don't

**Do not store the FOMA terminal in locations that are subject to humidity, dust or high temperatures.**

May cause a malfunction.



Instruction

**If being used by a child, have a guardian teach him/her the proper handling procedures. In addition, check that the child is using the FOMA terminal as directed.**

May result in bodily injury.



Instruction

**Keep the FOMA terminal out of the reach of young children.**

A young child may swallow components or suffer other bodily injury.



Instruction

**Be very careful when using the FOMA terminal connected to adapters repeatedly or for long periods of time.**

The FOMA terminal, battery pack or adapters may become warm if i-αpli, Videophone, or 1Seg is used for a long time while charging. Touch high temperature areas for a prolonged period of time may cause skin irritations, itchiness, or low-temperature burn in some people.

## Handling the FOMA terminal

### Warning



Don't

**Do not aim the Infrared port towards the eyes.**

May cause eye injury. In addition, do not aim or direct the Infrared port towards another Ir device as this may cause the device to malfunction.



Don't

**Do not point the illuminated light directly at someone's eyes.**

Do not use Picture Light near people's faces. Eyesight may be temporarily affected leading to accidents.

Precautions:

The picture light source used for this product may emit the light over the safety level for eyes when operations such as undirected adjustments are intentionally made. Therefore, do not disassemble the terminal. The terminal must be repaired by a docomo Shop or retailer.

EN60825-1:1994 A1:2002 & A2:2001

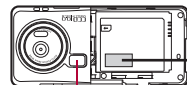
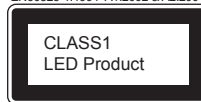

CAUTION-CLASS 2  
LED RADIATION WHEN  
OPEN DO NOT STARE  
INTO THE BEAM

Picture Light

### CAUTION:

Use of controls, adjustments or performance of procedure other than those specified herein may result in hazardous radiation exposure.

As the emission level from Picture Light LED used in this product is harmful to the eyes, do not attempt to disassemble the cabinet. Servicing is limited to qualified servicing station only.



Don't

**Do not put the FOMA terminal in the place where it could be affected by an expanded airbag, e.g., on the dashboard.**

If the air bag inflates, the FOMA terminal may hit you or others around you, resulting in bodily injury or damage to the FOMA terminal or other property.



Don't

**If you are using electronic medical equipment, do not put the FOMA terminal in your breast pocket or in the inside pocket of your jacket.**

Using the FOMA terminal in close proximity to electronic medical equipment may cause the equipment to malfunction.



Don't

**Do not allow water or other liquids, metal, flammable material, or other foreign objects to enter the FOMA card or microSD Card port on the FOMA terminal.**

May cause a fire, electric shock or other malfunctions.



Don't

**Do not shine the light at anyone driving a car or other vehicles.**

This may prevent a driver from driving safely and cause a traffic accident.



Instruction

**Turn off the FOMA terminal in areas where the use of mobile phones is prohibited, such as in aircraft or hospitals.**

The FOMA terminal may interfere with the operation of electronic devices and electronic medical equipment. In addition, if Auto power ON function is set to ON, disable this function before turning off your mobile phone.

Follow the instructions given by the respective medical facilities regarding the use of mobile phones on their premises.

In addition, actions such as using on a mobile phone aboard aircraft are prohibited and may be punishable by law.



Instruction

**During a call in which hands-free is set, keep the FOMA terminal away from the ears.**

**When you attach the earphone/microphone to the FOMA terminal to play games or music, do not make the volume too loud.**

Excessive high volume may damage your hearing. Also it may prevent you from hearing the ambient sounds and cause an accident.



Instruction

**If you have a weak heart, take extra precautions when setting functions such as the Vibrator and Ring tone volume for incoming calls.**

Various settings may have effects on your heart.



Instruction

**If you hear thunder while using the FOMA terminal outdoors, put the antenna back into the FOMA terminal and immediately turn it off and move to a safe location.**

There is a risk of being struck by lightning and suffering electric shock.



Instruction

**Turn the FOMA terminal off near high-precision electronic devices or devices that use weak electronic signals.**

The FOMA terminal may interfere with the operation of electronic devices.

**Take particular care with the following devices:**

Hearing aids, implanted cardiac pacemakers, implanted cardioverter-defibrillators, or other electronic medical equipment. Fire alarms, automatic doors, and other equipment controlled by electronic signals. If you use an implanted cardiac pacemaker, implanted cardioverter-defibrillator or other electronic medical equipment, contact the respective manufacturer or vendor to check whether the operation of the equipment is affected by signals.



Instruction

**In case that the display part or camera lens is damaged, make sure to pay attention to a broken glass and the exposed inside of the FOMA terminal.**

The surface of the display is covered by a protective film or the surface of camera lens are covered by a plastic panel so as to minimize the possibility of glass scattering. However, touching the broken display or camera lens may cause injury.



## Caution



Don't

**Do not swing the FOMA terminal by its antenna, strap, etc.**

The FOMA terminal may hit you or others around you, resulting in bodily injury or damage to the FOMA terminal or other property.



Don't

**Do not use the FOMA terminal in area with many people.**

The antenna may hit others, resulting in an accident such as bodily injury.



Don't

**Do not use the FOMA terminal with the damaged antenna.**

Touching the antenna may cause an accident such as burn or other injuries.



Don't

**When using Motion tracking, confirm the safety of surroundings, hold the FOMA terminal securely and do not swing it around more than necessary.**

Use Motion tracking to operate by tilting and shaking (or swinging) the FOMA terminal. The FOMA terminal may hit people or objects, if shaken (or swung) too much, and cause a serious accident or damage, etc.



Don't

**If using Motion tracking with the FOMA terminal to which metallic straps or others are attached, be careful not to hit people or objects with the straps.**

May result in bodily injury or damage to the FOMA terminal or other property.



Don't

**If the display is broken and the liquid crystal then leaks, do not lick or inhale the liquid or get the liquid on your skin. If the liquid comes into contact with your eyes or mouth, immediately rinse your eyes or mouth with clean water and see a doctor. If the liquid comes into contact with your skin or clothes, immediately wipe it off with alcohol, and wash with water and soap.**

May result in loss of eyesight and harm to your skin.



Don't

**While the ring tone is ringing or a melody is played on the FOMA terminal, do not put the ears closer to the speaker.**

This may cause hearing loss.



Don't

**On the surface of the display, there is a protective film for securing the safety (for preventing the reinforced glass panel from shattering) in case of the damage caused by a drop, impact, etc. Do not forcibly peel off or scratch this film.**

Using the FOMA terminal with the film removed may cause a bodily injury when the display is damaged.



Instruction

**Using the FOMA terminal in an automobile may sometimes affect the electronic equipment in some vehicle models.**

In such cases, stop using the FOMA terminal, as this could impede safe driving.



Instruction

**Use of the FOMA terminal may cause skin irritations such as itchiness, rashes or eczema in some people. If this occurs, immediately stop using the FOMA terminal and seek medical treatment.**

The following parts contain metals.

Part	Material	Surface treatment
Side key	Aluminum	Alumite
Metal section of 1Seg antenna (screw)	Iron	Nickel plating
External connector terminal		
Inside microSD Memory Card slot	SUS	Trivalent chrome plating
Metal section of 1Seg antenna (Installation part)		
Charger terminal		



Instruction

**Do not close the FOMA terminal on your fingers or objects such as the strap.** May result in bodily injury or cause a malfunction.



Instruction

**Watch 1Seg in a well-lit place, keeping a certain distance from the screen.** Otherwise, eyesight may be decreased.

## Handling battery pack

Check the type of battery using the information printed on the battery pack label.

Label	Battery type
Li-ion00	Lithium-ion



## Danger



Don't

**Do not touch terminals with metallic objects such as wires. In addition, do not carry or store the battery pack with metallic necklaces, etc.**

The battery pack may leak, overheat, explode or catch fire.



Don't

**If you are having difficulty fitting the battery pack to the FOMA terminal, do not use excessive pressure to force the battery into place. Check that the battery pack is facing the correct direction before you attach it.**

The battery pack may leak, overheat, explode or catch fire.



Don't

**Do not throw the battery pack into a fire.**

The battery pack may leak, overheat, explode or catch fire.



Don't

**Do not puncture, hit with a hammer or step on the battery pack.**

The battery pack may leak, overheat, explode or catch fire.



Instruction

**If the battery fluid comes into contact with your eyes, do not rub your eyes but immediately rinse your eyes with clean water. Then seek prompt medical treatment.**

May result in loss of eyesight.



## Warning



Don't

**If any trouble is found on the battery pack due to an external impact such as a deformation or scratches caused by a drop, immediately stop using it.**

The battery pack may leak, overheat, explode or catch fire. Other equipment may also be damaged or catch fire.



Instruction

**If the battery pack is not fully charged after the specified time has elapsed, stop charging.**

The battery pack may leak, overheat, explode or catch fire.



Instruction

**If the battery pack leaks or emits an unusual odor, immediately stop use and move it away from any flame or fire.**

The battery fluid is flammable and could ignite, causing a fire or explosion.



**Prevent your pet from biting the battery pack.**

Instruction

The battery pack may leak, overheat, explode or catch fire. Other equipment may also be damaged or catch fire.

## Caution



Don't

**Do not dispose of used battery packs in ordinary garbage.**

May cause fires or damage to the environment. Place tape over the terminals to insulate unnecessary battery packs, and take them to a docomo Shop, retailer or institution that handles used batteries in your area.



Don't

**Do not charge a wet battery pack.**

The battery pack may overheat, catch fire or explode.



Instruction

**If the battery fluid comes into contact with your skin or clothing, stop using the FOMA terminal immediately and rinse it off thoroughly with clean water.**

Battery fluid is harmful to your skin.

## Handling adapters

### Warning



Don't

**Do not use if the adapter's cord or power cord is damaged.**

May cause electric shock, overheating or fire.



Don't

**Never use the AC adapter or desktop holder in humid locations such as a bathroom.**

May result in electric shock.



Don't

**The DC adapter should only be used in negative grounded vehicles. Never use this adapter in positive grounded vehicles.**

May cause a fire.



Don't

**Do not touch the FOMA terminal or adapters if you hear thunder.**

There is a risk of being struck by lightning and suffering electric shock.



Don't

**Take care not to short-circuit the charging terminal when connected to an outlet or cigarette lighter socket. Also, take care not to allow any part of your body (hands, fingers, etc.) to come into contact with the charging terminal.**

May result in a fire, equipment malfunction, electric shock or bodily injury.



Don't

**Place the adapter and desktop holder on stable surfaces when charging. In addition, do not cover or wrap the adapter or desktop holder with clothing or bedding.**

The FOMA terminal may detach, overheat, or cause a fire or malfunction.



Don't

**Do not place heavy objects on the adapter's cord or power cord.**

May cause an electric shock or fire.



No wet hands

**Do not handle the cord and plug of the adapters with wet hands.**

May result in electric shock.

**Always use the specified power supply and voltage.**

Instruction

Using the incorrect voltage may cause a fire or malfunction.

When using overseas, use the AC adapter that is available overseas.

AC adapter: 100V AC

DC adapter: 12/24V DC (for negative grounded vehicles only)

AC adapter available overseas: 100 to 240V AC (Connect only with household AC outlet)

**If the fuse in the DC adapter blows, always replace it with a fuse of the specified type.**

Instruction

Using the fuse other than the specified one may cause a fire or malfunction. Refer to the respective manuals for information on the correct fuse specifications.

**Wipe off any dust on the power plug.**

Instruction

May cause a fire.

**When plugging the AC adapter into the outlet, make sure that no metallic straps or other metallic objects are caught between the plug and the socket.**

Instruction

May cause electric shock, short-circuiting or fire.

**Always grasp the power plug when unplugging the adapters from the outlet or cigarette lighter socket. Do not forcibly pull by the adapter's cord or power cord.**

Instruction

Pulling on the cord may damage the cord and cause an electric shock or fire.



Unplug

**Unplug the power cord from the outlet when not using for a long time.**

May cause an electric shock, fire, or malfunction.



Unplug

**Should water or other liquids enter the adapters, remove the power plug from the outlet or cigarette lighter socket immediately.**

May cause an electric shock, smoke emission or fire.



Unplug

**Always unplug the power plug from the outlet or cigarette lighter socket before cleaning the adapters.**

May result in electric shock.

**Handling FOMA card****Caution****Be careful with the cutting surface when detaching the FOMA card (IC).**

Instruction

May cause injuries to your hand or fingers.

**Handling mobile phones near electronic medical equipment**

The precautions detailed here conform to the guidelines drawn up by the Electromagnetic Compatibility Conference Japan, regarding the protection of electronic medical equipment from signals emitted by mobile phones.

**Warning****Observe the following in hospitals or other medical facilities.**

Instruction

- Do not take your FOMA terminal into operating rooms, ICUs (Intensive Care Units) or CCUs (Coronary Care Units).
- Turn off your FOMA terminal inside hospital wards.
- Turn off your FOMA terminal even when you are in an area outside hospital wards, such as a hospital lobby, since electronic medical equipment may be in use nearby.
- Where a medical facility has specific instructions prohibiting the carrying and use of mobile phones, observe those instructions strictly.
- If Auto power ON function is set to ON, disable this function before turning off your mobile phone.





Instruction

**Turn off your FOMA terminal in crowded places such as rush-hour trains in case somebody nearby is using an implanted cardiac pacemaker or implanted cardioverter-defibrillator.**

Electromagnetic signals may affect the operation of implanted cardiac pacemakers and implanted cardioverter-defibrillators.



Instruction

**If you have an implanted cardiac pacemaker or an implanted cardioverter-defibrillator, always carry or use your FOMA terminal at least 22 cm away from your implant.**

Electromagnetic signals may affect the operation of implanted cardiac pacemakers and implanted cardioverter-defibrillators.



Instruction

**Patients receiving medical treatment away from a hospital or medical facility (e.g. home treatment) who are using electronic medical equipment other than implanted cardiac pacemakers or implanted cardioverter-defibrillators should consult the respective manufacturers for information regarding the effects of signals on the equipment.**

Electromagnetic signals may affect the operation of electronic medical equipment.

## Handling precautions

### General notes

- **Do not expose to water.**  
FOMA terminal, battery pack, adapters and FOMA card are not waterproof. Do not use in humid or steamy areas such as bathrooms and avoid exposing to rain and other forms of moisture. If FOMA terminal is carried close to skin, perspiration may cause internal components to corrode and result in malfunction. Note that if problem is found to be due to moisture, handset and parts are not covered by warranty and in some cases may be irreparable. Even where repairs are possible, repair charges will be incurred since damage is not covered by warranty.
- **Clean only with a soft and dry cloth (such as the type used for eyeglasses).**  
The surface of the handset's LCD has a special coating to improve the visibility of the color display. Forceful rubbing of LCD with a dry cloth may scratch LCD surface. Handle the handset carefully and clean using a soft and dry cloth (such as the type used for eyeglasses). Note also that LCD coating may peel off or stain if moisture or soiling is left on the surface for a long period. Never use chemicals such as alcohol, thinners, benzene or detergents, as these agents may erase the printing on the handset or cause discoloration.
- **Occasionally clean terminals with a dry cotton swab, etc.**  
Unclean terminals may result in poor connections and loss of power. Keep terminal clean with a dry cotton swab, etc. Take care of the terminal while cleaning it.
- **Do not place the handset near an air conditioning vent.**  
Condensation formed due to rapid changes in temperature may cause internal corrosion and lead to malfunction.
- **Do not apply excessive force to the FOMA terminal and battery pack when using them.**  
Carrying the handset in a tightly packed bag, or sitting on the handset in your pocket may cause a damage to display, other internal components or battery pack, or result in malfunction. Keeping an external connector device plugged into the external connector terminal (earphone/microphone terminal) may cause a damage to the connector or result in malfunction.
- **Read the manuals supplied with the FOMA terminal, adapters, and desktop holder carefully.**
- **Do not rub or scratch the display with metal, etc.**  
May scratch the handset and cause malfunction or damage.

## Notes about the FOMA terminal

- **Do not forcefully press a surface of the touch panel, or operate with a pointed object such as a fingernail, ballpoint pen, pin, etc.**  
May damage the touch panel.
- **Avoid using the handset in extremely high or low temperatures.**  
Use the FOMA terminal within the range of a temperature between 5°C and 35°C and a humidity between 45% and 85%.
- **Using the handset close to landline phones, TVs or radios may affect the operation of such equipment. Move as far away as possible from such items before use.**
- **Keep a separate memo and note information stored in the FOMA terminal.**  
DOCOMO shall not be liable for any loss of content.
- **Do not drop or otherwise subject the FOMA terminal to severe impact.**  
May damage the handset and cause malfunction.
- **When connecting an external connector device to the external connector terminal (earphone/microphone terminal), do not put it in obliquely or do not pull it while it is plugged in.**  
May damage the handset and cause malfunction.

- **Do not close the FOMA terminal on strap, etc.**  
May damage the handset and cause malfunction.
- **FOMA terminal may become warm during using or charging but this is not a malfunction.**
- **Do not leave the camera in direct sunlight.**  
May cause discoloration or burn-in.
- **Use the FOMA terminal with the external connector terminal cover and microSD Card slot cover on.**  
Dust, water and others enter inside and cause a malfunction.
- **Do not use the FOMA terminal without the back cover.**  
May detach the battery pack or cause malfunction or damage.
- **Do not cover the surface of the display, keys, or buttons with an extremely thick sticker.**  
May cause malfunction.
- **While using a microSD Card, do not remove the card or turn off the FOMA terminal.**  
May cause data loss or malfunction.
- **Never place a magnetic card near or in the FOMA terminal.**  
The stored magnetic data in cash cards, credit cards, telephone cards, floppy disks, etc. may be erased.
- **Never place magnetized items near the FOMA terminal.**  
Putting highly magnetized items closer may cause a malfunction.

## Notes about battery pack

- **Battery pack is a consumable product.**  
Though usage time varies with use, change battery if battery level is extremely low even after fully charged. Purchase a specified new battery pack.
  - **Charge battery in areas where ambient temperature is between 5°C and 35°C.**
  - **Always charge the battery before the first use or after not using battery for a long time.**
  - **The usage time for a battery pack depends on the usage and deterioration of battery pack.**
  - **Depending on usage, the battery pack may swell as it approaches the end of its service life but this will not cause problems.**
  - **Note the followings when the battery pack is stored for a long term.**
    - The storage with the battery pack fully charged (immediately after charging is completed)
    - The storage with no battery level (cannot turn the FOMA terminal on)
- May lower the performance or shorten the life of the battery pack. The second or third level of the battery pack icon is recommended as the battery level for long-term storage.

## Notes about adapters

- Charge battery in areas where ambient temperature is between 5°C and 35°C.
- Do not charge battery pack in the following locations:
  - Areas with high humidity or dust, or in areas exposed to strong vibrations
  - Close to landline phones, TVs, radios, etc.
- Adapters may become warm during charging but this is not a malfunction.
- Do not use DC adapter to charge battery when the car engine is not running.  
May cause car battery to run down.
- When using an outlet with a feature to prevent the plug from being removed accidentally, follow instructions in the outlet user's guide.
- Do not subject to strong force or impacts. Also, do not disfigure the charger terminals.  
May cause a malfunction.

## Notes about FOMA card

- Do not apply unnecessary force when inserting/removing the FOMA card.
- FOMA card may become warm during using but this is not a malfunction.
- Customer is responsible for malfunctions arising from inserting FOMA card into a different IC card reader/writer.
- Always keep IC area clean.
- Clean only with a soft and dry cloth (such as the type used for eyeglasses).
- Keep a separate memo and note information stored in the FOMA card.  
DOCOMO shall not be liable for any loss of content.
- To protect the environment, please take any unnecessary FOMA cards to a docomo Shop or retailer.
- Avoid using in extremely high or low temperatures.
- Do not damage, touch haphazardly or short-circuit the IC.  
May cause data loss or malfunction.
- Do not drop or otherwise subject the FOMA card to severe impact.  
May cause a malfunction.
- Never bend or place heavy objects on the FOMA card.  
May cause a malfunction.
- Do not insert the FOMA card to the FOMA terminal with a label or sticker attached on the card.  
May cause a malfunction.

## Notes on using Bluetooth function

- FOMA terminal supports the security function that meets the Bluetooth specification for the security during communication using Bluetooth function. However, the security may not be sufficient depending on the configuration. Take care of the security while making communication using Bluetooth function.
- Even if any leak of data or information occurs while making communication using Bluetooth function, DOCOMO shall not be liable for any loss of content.
- With FOMA terminal, use headset, hands-free, audio, keyboard, dial-up communication, object push and serial port. Also, the audio/video remote-control may be available depending on the audio (only with compatible Bluetooth devices).
- Radio frequencies  
The radio frequencies the Bluetooth function of the FOMA terminal uses are as follows:

2.4FH1
■■■■■■■■■■

This wireless device uses 2.4 GHz band. The modulation system is the FH-SS system and a coverage distance is 10 m or less. All radio frequencies are used and the frequencies for mobile object identifiers shall not be avoided.

- **Cautions on using Bluetooth devices**  
Bluetooth operates at radio frequencies assigned to the in-house radio stations for a mobile object identifier that have to be licensed and is used in production lines of a factory, specific unlicensed low power radio stations, and amateur radio stations (hereafter, referred to “another radio station”) in addition to industrial, scientific, medical devices, or home electric appliances such as microwave ovens.
  1. Before using this product, make sure that “another radio station” is not operating nearby.
  2. If radio interference between this product and “another radio station” occurs, avoid interference by moving immediately to another place or “turning off the power”.
  3. Contact the number listed in “General Inquiries” on the back of this manual for further details.

## FeliCa reader/writer

- The FeliCa reader/writer function in the FOMA terminal uses weak electric waves in the handling of which does not require a license of radio station.
- The frequency in use is the 13.56 MHz band. When another reader/writer is being used nearby, keep enough distance from it. Make sure that there is no radio station using the same frequency band in the nearby area.

## Caution

- **Never use the FOMA terminal that is modified. Using a modified device violates the Radio Law.**  
The FOMA terminal has acquired the certification of conformity with technical regulations for the specified radio station based on the Radio Law, and the “Technical Conformity Mark ” is printed on the model nameplate of the FOMA terminal as a proof. If the screws of FOMA terminal are removed and a modification is given to the inside, the certification of conformity with technical regulations will become invalid. Never use the FOMA terminal without the valid certification. Doing so violates the Radio Law.

- **Be careful when using the FOMA terminal while driving a motor vehicle.**  
While driving, using a mobile phone in hand is regarded as a punishable act. If there is no choice but to receive a call, use hands-free and tell the caller that you will “call back” and then pull over to a safe place to make a call.
- **Use the Bluetooth function only in Japan.**  
The Bluetooth function in the FOMA terminal conforms to the domestic radio wave standards and is authorized. Using the function overseas may result in punishment.
- **Use the FeliCa reader/writer function only in Japan.**  
The FeliCa reader/writer function in the FOMA terminal conforms to the domestic radio wave standards. Using the function overseas may result in punishment.

# Before Using the Handset

Component names and functions . . . . .	24
Viewing display . . . . .	28
Optical TOUCH CRUISER . . . . .	34
Setting and selecting menu. . . . .	36
Operations in viewer position . . . . .	<Touch panel>39
Displaying Support Book . . . . .	<Support Book>45
Using FOMA card . . . . .	<FOMA card>45
Attaching/Removing battery pack . . . . .	48
Charging . . . . .	49
Checking battery level. . . . .	<Battery level>52
Checking battery pack status . . . . .	<Self-check>53
Turning power ON/OFF . . . . .	<Power ON/OFF>54
Changing screen display to English . . . . .	<Select language>54
Making initial setting . . . . .	<Initial setting>54
Setting date and time . . . . .	<Date settings>55
Notifying the other party of your phone number . . . . .	<Notify caller ID>56
Checking your own phone number . . . . .	<Own number>56

## Component names and functions

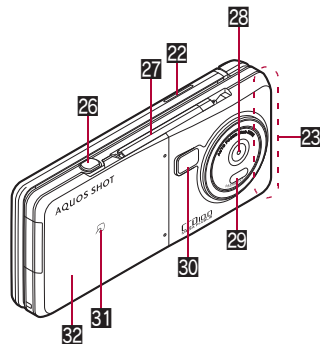
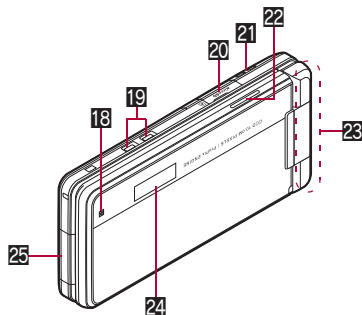
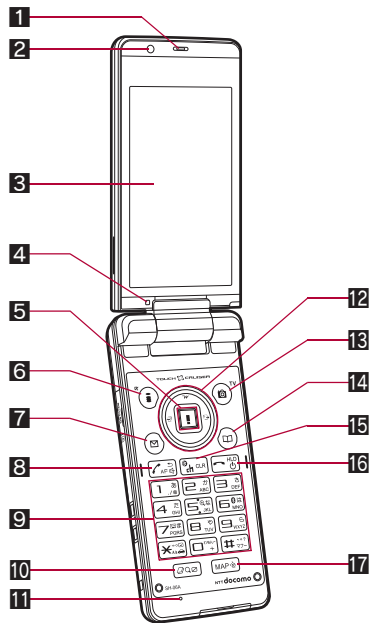







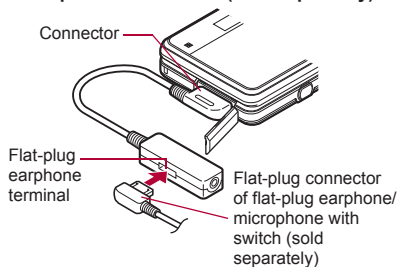











### Using earphone

Connect an earphone compatible with external connector terminal (sold separately). When using an earphone which does not support external connector terminal, connect with a plug adapter (sold separately).

### Connection example for flat-plug earphone/microphone with switch (sold separately)



- Key illustrations are examples and may look different from actual keys.

- 1 Earpiece**
- Listen to the other party's voice.
  - Listen to Record message/Voice memo.
- 2 Sub camera**
- Use to shoot still pictures of yourself.
  - Use to send images of yourself during a Videophone call.
- 3 Main display/Touch panel (P. 28, P. 39)**
- 4 Brightness sensor (P. 103)**
- The sensor detects the brightness of the surrounding area and automatically adjusts the display brightness and turns on/off the keypad backlight.
  - Do not cover the sensor area with your hand or a sticker. May interfere with the sensor.
- 5 : Optical TOUCH CRUISER (P. 34)**
- Slide the finger to perform the same operations as those for  of Multi-guide key.
- 6 : i-mode/Operation guidance key**
- Press to use i-mode (P. 164).
  - Press to execute the functions of the operation guidance (P. 28).
- 7 : Mail/Operation guidance key**
- Press to use mail functions (P. 130).
  - Press to execute the functions of the operation guidance (P. 28).
- 8 : Start/Hands-free/Eco key**
- Press to make or receive a voice call.
  - Press to use hands-free (P. 59).
  - Press to set the Eco mode (Power saver) (P. 101).
- 9  to , , , : Dial/Text input keys**
- Press to enter phone numbers or texts.
- 10 : Multi/Quick search/VeilView key**
- Press to use Multi Assistant (P. 369).
  - Press to use Quick search (P. 379).
  - Press to enable/disable the VeilView (P. 110).
- 11 Mouthpiece/Microphone**
- Sends out your own voice.
- 12 : Multi-guide key**
- Move the cursor to select an item and execute or set (P. 28).
- 13 : Camera/TV/Operation guidance key**
- Press to activate the camera/1Seg (P. 208, P. 231).
  - Press to execute the functions of the operation guidance (P. 28).
- 14 : Phonebook/Operation guidance key**
- Press to use the phonebook (P. 87).
  - Press to execute the functions of the operation guidance (P. 28).
- 15  (ch): i-Channel/Clear key**
- Press to display the channel list (P. 194).
  - Press to return to the previous screen.
  - Press to delete texts or phone numbers.
- 16 : Power/End key**
- Press for 2+ seconds to turn the power on/off (P. 54).
  - Use to end the function being activated and return to stand-by display.
- 17 : MAP/GPS key**
- Press to activate GPS compatible i-appli (P. 302).
  - Press to check your present location. (P. 301).
- 18 Called/Charging LED**
- Flashes while receiving a call, etc. (P. 107).
  - Illuminates while charging (P. 49).
- 19 Charger terminal (P. 51)**
- This is a terminal for charging with the desktop holder.
- 20 microSD Card slot (P. 336)**
- 21 Strap ring**
- 22 Speakers**
- Emits ring tones, music, etc.
  - Emits the other party's voice during hands-free operation.
- 23 FOMA antenna**
- The FOMA antenna is built in. To speak in better conditions, do not cover the antenna area by hand.
- 24 Sub display (P. 28)**
- 25 External connector terminal**
- This is a terminal used while charging, connecting the earphone, etc.
  - Connect to an external device such as AC adapter/DC adapter or FOMA USB Cable with Charge Function 02 (sold separately) (P. 50, P. 346).
- 26 : Side key**
- Use to shoot still pictures or moving pictures (P. 208, P. 211).
  - Press with the FOMA terminal closed to display the clock on the sub display.
- 27 1Seg antenna (P. 229)**
- Use to receive 1Seg.

**28 Main camera**

- Use to shoot still pictures or moving pictures (☞ P. 202).
- Use to send a camera image shot during a Videophone call to the other party (☞ P. 58).

**29 Infrared port**

- Use for the Ir communication (☞ P. 352).
- Use for the Ir remote control (☞ P. 356).

**30 Picture light**

- Illuminates while activating the camera (☞ P. 202).
- Illuminates/Flashes during shooting (☞ P. 208, P. 211).

**31  mark**







- The IC card is included (The IC card cannot be removed). Use Osaifu-Keitai holding the  mark up to the scanning device (☞ P. 289).
- Use to send and receive data via the iC communication (☞ P. 356).

















**32 Back cover (☞ P. 48)**

- A radio frequency-preventing sticker is attached on the back of the back cover. Do not peel off this sticker.



**■ Key operations for stand-by display**

Operate each key in the stand-by display to perform the following action.

Key	Operations	Operations when pressing for 1+ seconds
	To display iMenu (☞ P. 164)	To display the i-appli software list screen (☞ P. 263)
	To display Mail menu (☞ P. 130)	To display the compose message screen (☞ P. 130)
	To activate camera (☞ P. 208)	To activate 1Seg (☞ P. 231)
	To display phonebook (☞ P. 87)	To display the phonebook entry screen (☞ P. 83)
	To display start menu (☞ P. 36)	To use the Lock selection screen (☞ P. 119)
	To display the Redial list screen (☞ P. 62)	To display Sent messages history (☞ P. 151)
	To display the Received calls list screen (☞ P. 62)	To display Received messages history (☞ P. 151)

Key	Operations	Operations when pressing for 1+ seconds
	To display the i-Widget screen (☞ P. 285)	To display the earpiece volume adjustment screen (☞ P. 94)
	To display Shortcut menu (☞ P. 379)	
	To display the phone number entry screen (☞ P. 59)	To set the Eco mode (Power saver) (☞ P. 101)
	–	To turn off the power*1 (☞ P. 54)
	To display channel list (☞ P. 194)	
	To enter 1	To execute assigned functions (☞ P. 379)
	To enter 2	
	To enter 3	
	To enter 4	To activate the Quick Stand-by Display Setting mode (☞ P. 98)
	To enter 5	To set font size collectively (☞ P. 109)
	To enter 6	To turn on/off the Bluetooth power (☞ P. 392)
	To enter 7	To display the Voice memos/Recorded messages screen (☞ P. 76, P. 382)
	To enter 8	To start to use 2in1 (☞ P. 418) To switch 2in1 mode (☞ P. 419)
	To enter 9	To reset Kisekae Tool settings (☞ P. 105) To reset Font style setting (☞ P. 109)
	To enter 0	To enter +
	To enter *	To enable/disable the Public mode (Drive mode) (☞ P. 72)
	To enter #	To enable/disable the Manner mode (☞ P. 97)



Key	Operations	Operations when pressing for 1+ seconds
	To activate Quick search (P. 379)	To enable/disable VeilView (P. 110)
	To activate GPS compatible i-appli (P. 302)	To check your present location (P. 301)
	To display clock on the sub display*2	To turn on/off picture light*2

\*1 Press for 2+ seconds.

\*2 Available only with the FOMA terminal closed.

## Opening the FOMA terminal

To use the FOMA terminal, open it (normal position) or use it in the viewer position.

- When the FOMA terminal is switched to the viewer position for the first time while the stand-by display is displayed, the screen rotation setting screen automatically appears. Set the function to be activated when the FOMA terminal is switched to the viewer position while the stand-by display is displayed in the normal position (P. 100).
  - For details on operating with the touch panel (P. 39)
- The operation can be continued with the touch panel when the FOMA terminal is switched to the viewer position while the function is being used in the normal position.
  - Some functions are not available in the viewer position.
- When carrying, keeping the FOMA terminal closed as shown in the diagram for step 1 is recommended.

### Viewer position

1



Open carefully with both hands.

2

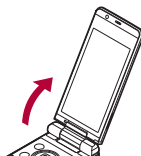

Open the display until it stops midway.

3

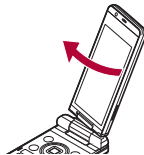

Rotate the display 180° to the right.

4

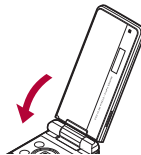

Flip the display forward.

5

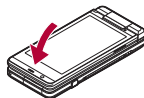

### Cautions when rotating

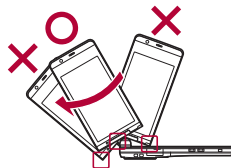

- Note the following when rotating the FOMA terminal display.
  - Do not hit the key surface, etc. May damage the key surface (See “Cautions when rotating”).
  - Do not rotate in the opposite direction or further than 180°.

## Multi-guide key and Operation guidance key

Use to select or execute the menus that appear in the operation guidance.  
The following shows the keys assigned to select or execute the menu items that appear in the guidance.

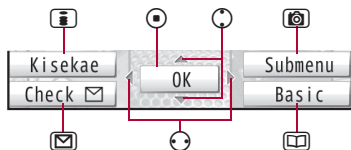

### Operation guidance menu

In the operation guidance, menus appear according to the function being used and situation.

The following table describes examples of the main operation guidance menus that appear.

OK	Sets the selected item
Submenu	Displays the Submenu
Agree	Checks selected image, music, etc.
Back	Returns to the previous screen
Play/Stop	Plays/Stops i-motion, music, etc.
Full	Displays selected images, etc. in full screen
Show all	Displays sorted files, etc. as a list
1/1 or Zoom↓	Displays selected images, etc. in actual/reduced size
Mail	Displays the compose message screen
Send	Sends a mail
Cancel	Cancels the operation such as receiving a mail
SelAll/ClrAll	Selects/Disables all selectable items (Up to 50 items can be selected/disabled depending on the function)
Page ▲/Page ▼	Scrolls the display by page
Close	Closes the Submenu, etc.

## Viewing display

- Icons are shown in the order of main display and sub display.

### Main display

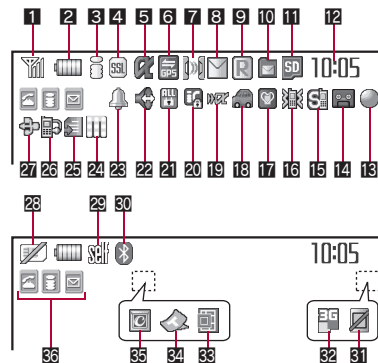

### Sub display

The following shows a screen when Sub) Clock display (P. 101) is set to [Stdby clock(H·L)].

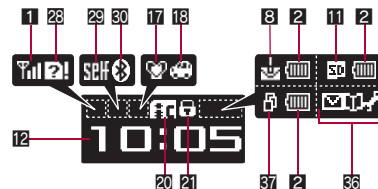

### 1 Signal status

	Indication of the signal strength Strong $\longleftrightarrow$ Weak
--	--

- When appears, the handset is outside the service area or in a place with no signal. Signal icon can be changed (☞ P. 106).

### 2 Battery level (☞ P. 52)

	Indicates battery level
--	-------------------------

- Battery icon flashes during charging.
- Battery icon can be changed (☞ P. 52).

### 3 i-mode/Full Browser (☞ P. 164, P. 167)

	Indicates i-mode/Full Browser status
--	--------------------------------------

### 4 SSL/TLS (☞ P. 164, P. 167, P. 186)

	SSL/TLS compatible sites are viewed SSL/TLS compatible Internet web pages are viewed SSL/TLS pages are viewed
--	---

- When this icon appears while Multi Assistant is used, function such as i-mode, Full Browser, i-appli or Software update is being used with Multi Assistant.

### 5 i-appli (☞ P. 263)

	i-appli is being activated i-appli stand-by is being activated
	i-appli stand-by is set*
	i-appliDX is being activated i-appliDX stand-by is being activated
	i-appliDX stand-by is set*

- \* i-appli is set as the stand-by display, but cannot be used.
- Does not appear in the i-Widget screen.

### 6 GPS (☞ P. 301, P. 304)

	Location request menu is set to [Loc. provision:ON]/ [Reject No. unset] Location request menu is set to [Permission sched.] and Location provision is permitted
	Location request menu is set to [Permission sched.] and Location provision is rejected
	GPS positioning

### 7 Ir communication/Bluetooth communication/External device

	Data is communicated with another device using the Ir communication function (☞ P. 352) Data is sent using the Ir remote control (☞ P. 356)
	Data is communicated with another device using the Bluetooth function (☞ P. 395)
	Connected to commercially available Bluetooth compatible keyboard (☞ P. 393)
	Connected to an external device and transmitting packets
	Connected to an external device and sending/receiving packet data
	Connected to an external device and transmitting 64K data

### 8 i-mode mail/SMS/Area Mail received (☞ P. 138)

	Indicates the status of the i-mode mail/SMS/Area Mail reception Indicates the status of the memory to store received mail
--	--

- \* Appears when Area mail is received.

### 9 Message R/F received (☞ P. 156)

	Indicates the reception status of the Message R/F Indicates the status of the memory to store Message R/F
--	--

**10 Storage status of i-mode center (☞ P. 138, P. 156)**

	Indicates the storage status of the mail and Message R/F
--	--

- May not appear even if messages are held at the i-mode center.

**11 microSD Card (☞ P. 335)**

	microSD Card is inserted
	microSD Card is being used
	Appears when microSD Card is not recognized

**12 Clock display (☞ P. 55)**

- Small clock icon can be changed (☞ P. 106).

**13 1Seg being recorded (☞ P. 237)**

	1Seg is being recorded
--	------------------------

**14 Record message (☞ P. 74)**

	Record message is set
--	-----------------------

- When there are messages, [ ] to [ ] appears, indicating the total number of both types of messages. When there are three Record messages (voice calls) and two Record messages (Videophone), [ ] appears.

**15 Silent (☞ P. 93)**

	The phone ring volume [Silent] is set
--	---------------------------------------

**16 Vibrator (☞ P. 95)**

	Vibration mode is set
--	-----------------------

**17 Manner mode (☞ P. 97)**

	Manner mode is set
--	--------------------

**18 Public mode (Drive mode) (☞ P. 72)**

	Public mode (Drive mode) is set
--	---------------------------------

**19 i-αpli call (☞ P. 280)**

	New i-αpli call
--	-----------------

**20 IC card lock (☞ P. 290)**

	IC card is locked
--	-------------------

**21 Restriction (☞ P. 115, P. 121)**

	Secret mode is set
	Secret data is being edited
	Keypad dial lock
	All lock is set
	Function lock is set
	Keypad dial lock and Function lock are set
	Secret mode, Function lock and Keypad dial lock are set
	Side key lock, Secret mode, Function lock and Keypad dial lock are set
	Side key lock is set

**22 Hands-free (☞ P. 59, P. 392)**

	Hands-free in progress
	USB hands-free in progress
	Mute in progress (only when rotated the display)
	Bluetooth hands-free in progress

**23 Alarm (☞ P. 238, P. 371, P. 375)**



	Alarm is set Schedule alarm is set* Reception reserve alarm is set* Recording reserve alarm is set* Wakeup TV is set*
--	---

\* Appears only when an Alarm is set for that day.

**24 Music&Video Channel program reservation** (P. 247)

	Appears 12 hours before Music&Video Channel program distribution
--	--

**25 i-mode mail send reservation** (P. 137)

	Mail with send reservation
	Mail failed to be automatically sent



**26 Earphone/microphone connection** (P. 386)

	While Auto answer setting is set to [ON] with an earphone/microphone (sold separately) connected
---	--

**27 USB mode** (P. 346)

	FOMA USB Cable with Charge Function 02 (sold separately) is connected in the Communication mode
---	---



**28 FOMA card error**

	Appears when FOMA card is malfunctioning or not inserted
	Appears when a card other than the FOMA card is inserted

**29 Self mode** (P. 117)

	Self mode is set
---	------------------

**30 Bluetooth** (P. 387)

	Stand-by for Bluetooth registration Stand-by for Bluetooth connection Connected to Bluetooth
	During power saver mode for Bluetooth (Appears when data is not transmitted from the FOMA terminal for a set length of time)







- Illuminates during stand-by for Bluetooth registration, flashes at approximately 1-second intervals during stand-by for Bluetooth connection, and flashes at approximately 0.5-second intervals during Bluetooth connection.
- Does not appear while displaying 4.

**31 VeilView** (P. 110)



	VeilView is set
---	-----------------

- Does not appear while displaying 16 or 32.

**32 3G/GSM**

	3G network (Packet transmission is available)
	3G network (Packet transmission is available/Call is not available)
	3G network (Packet transmission is not available)
	GSM/GPRS network (Packet transmission is available)
	GSM/GPRS network (Packet transmission is available/Call is not available)
	GSM/GPRS network (Packet transmission is not available)

**33 Status of Comics setting** (P. 362)

	Frame display is set
	Page display is set

- Does not appear while displaying 22 or 35.

**34 ToruCa** (P. 292)

	Unread ToruCa
---	---------------

- Does not appear while displaying 22, 33 or 35.

**35 Receiving information** (P. 196)

	New information
---	-----------------

- Does not appear while displaying 22.

**36 Multitask** (P. 369)

Indicates functions that are running.

- While two or more functions are running, the Multitask icon also appears on the sub display.

	Four or more applications are running		Shoot moving picture
			Character reader (OCR)

	Videophone		Bar code reader
	Voice call		Card reader
	Phonebook		Information reader
	Modem transmission (appears during data transmission)		Shotdeco
	Software update		Voice recorder
	Map/GPS		Schedule
	Bluetooth function		Text memo, Stand-by memo
	Receive via Ir/IC/USB/Bluetooth communication		Calculator
	i-appli		Manga&BookReader
	i-mode, i-Channel, Full Browser, Internet movie player		Quick search
	i-concier		ToruCa
	Receive information		Alarm
	Mail, SMS, Message R/F, Check new messages		Timer
	Mail/Decome-Anime/SMS being composed		microSD
	Received calls		General settings
	Received messages history		Voice memo/Record message
	Own number		Document Viewer
	Redial		1Seg
	Sent messages history		Reception reserve/Recording reserve alarm sounds
			Data Security Service
			Data box
			MUSIC

	Shoot still picture		Presentation support
--	---------------------	--	----------------------

### 37 Operation in progress

	A screen other than stand-by appears in the main display
--	--

- Does not appear while displaying 36.

- microSD Card is referred to as [microSD] or [SD] on the FOMA terminal (P. 335).
- Some of the screen shots in this manual have been modified or abbreviated.
- The display for the FOMA terminal is manufactured using high-precision technology, but it may occasionally contain dots that fail to light or that remain permanently lit. This is not a malfunction.
- The display time of sub display follows the light duration setting.
- The icon of sub display cannot be changed.

### Checking notices with stock icon

Display stock icons in stand-by when a call is missed or new mail is received. In stand-by, select stock icons to check notice details.

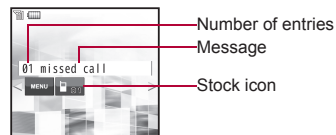

### Stock icon type

Icon	Message	Page
	xx missed call*1	P. 73
	Recorded messages xx message/xx message	P. 76
	xx voice mail*1	P. 410
	xx mail message	P. 138, P. 161