

General Inquiries <docomo Information Center>

(Business hours: 9:00 a.m. to 8:00 p.m.)

 **0120-005-250 (toll free)**

※ Service available in: English, Portuguese, Chinese, Spanish.

※ Unavailable from part of IP phones.

(Business hours: 9:00 a.m. to 8:00 p.m. (open all year round))

■ **From DOCOMO mobile phones
(In Japanese only)**

 **(No prefix) 151 (toll free)**

※ Unavailable from land-line phones, etc.

■ **From land-line phones (In Japanese only)**

 **0120-800-000 (toll free)**

※ Unavailable from part of IP phones.

● Please confirm the phone number before you dial.

● For Applications or Repairs and After-Sales Service, please contact the above-mentioned information center or the docomo Shop etc. near you on the NTT DOCOMO website.

NTT DOCOMO website <http://www.nttdocomo.co.jp/english/>

Repairs

(Business hours: 24 hours (open all year round))

■ **From DOCOMO mobile phones
(In Japanese only)**

 **(No prefix) 113 (toll free)**

※ Unavailable from land-line phones, etc.

■ **From land-line phones (In Japanese only)**

 **0120-800-000 (toll free)**

※ Unavailable from part of IP phones.

For loss, theft, malfunction, and inquiries while overseas

(available 24 hours a day)

■ **From DOCOMO mobile phones**

**International call access code
for the country you stay -81-3-6832-6600* (toll free)**

* You are charged a call fee to Japan when calling from a land-line phone, etc.

※ If you use SH-07E, you should dial the number +81-3-6832-6600 (to enter "+", touch "0" for a while).

■ **From land-line phones <Universal number>**

**Universal number
international prefix -8000120-0151***

* You might be charged a domestic call fee according to the call rate for the country you stay.

※ For international call access codes for major countries and universal number international prefix, refer to DOCOMO International Services website.

● **If you lose your handset or have it stolen, immediately take the steps necessary for suspending the use of the handset.**

● **If the handset you purchased is damaged, bring your handset to a repair counter specified by DOCOMO after returning to Japan.**



Don't forget your mobile phone... or your manners!

When using your mobile phone in a public place, don't forget to show common courtesy and consideration for others around you.

NTT
docomo

AQUOS PHONE si SH-07E

INSTRUCTION MANUAL '13.6

Sales: NTT DOCOMO, INC.
Manufacturer: SHARP Corporation

Introduction

Thank you for purchasing “SH-07E”.

Be sure to read this manual before and during use to ensure proper operation.

Checking operation method

Quick Start Guide (Basic package) (in Japanese only)

This guide describes operations of basic functions.

User’s Manual (App of the handset) (in Japanese only)

This manual describes detailed guidance and operations of functions.

In the home screen, [☰] ▶ [Instruction Manual]

To display help: [☰] ▶ [ヘルプ] (Help)

User’s Manual (in PDF format)

This manual describes detailed guidance and operations of functions.

Download from the DOCOMO website

<http://www.nttdocomo.co.jp/english/support/trouble/manual/download/index.html>

※ The URL and contents of this manual are subject to change without prior notice.

Tips of smartphone (Widget of the handset) (in Japanese only)

A widget to joyfully learn convenient functions and basic operations that you should know of the handset with Docomodake.

In the home screen, 

- The screens and illustrations in this manual are shown as examples. The actual screens and illustrations may differ.
- The explanations in this manual are based on the case when the home app is docomo Palette UI. If you change the home app, operation procedures etc. may be different from the explanations of this manual.
- Note that “SH-07E” is referred to as “handset” in this manual.
- This manual refers to microSD Card, microSDHC Card or microSDXC Card as “microSD Card” or “microSD”.
- Reproduction of this manual in part or in whole is prohibited.
- The contents of this manual are subject to change without prior notice.

Basic package



SH-07E
(includes warranty)



Back Cover SH70



Battery Pack SH42

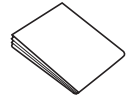

Quick Start Guide
(in Japanese only)

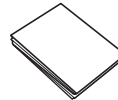

++ご利用にあたっての
注意事項 (in Japanese
only)

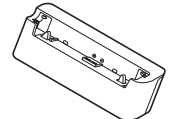

Desktop Holder SH44





++アンテナ付イヤホンケーブル
(sample) (includes user's guide)

- For details on other optional parts  P. 82







Precautions (ALWAYS FOLLOW THESE DIRECTIONS)

- Before use, read these "Precautions" carefully and use your handset properly.
Keep this manual in a safe place for future reference.
- These precautions contain information intended to prevent bodily injury to the user and to surrounding people, as well as damage to property, and must be observed at all times.

The following symbols indicate the different degrees of injury or damage that may occur if information provided is not observed and the handset is used improperly.

 Danger	This symbol indicates that "death or serious bodily injury may directly and immediately result from improper use".
 Warning	This symbol indicates that "death or serious bodily injury may result from improper use".
 Caution	This symbol indicates that "minor injury and/or property damage may result from improper use".

The following symbols indicate specific directions.







 Indicates a prohibited action .	 Indicates not to handle the device with wet hands.
 Indicates not to disassemble the device.	 Indicates that instructions specified are compulsory (must be followed) .
 Indicates not to use the device near water or get it wet.	 Indicates that the power cord must be unplugged from the outlet.

"Precautions" is explained in the following seven sections.





- Handling the handset, battery pack, adapters, desktop holder and docomo mini UIM card (general) P. 3
- Handling the handset P. 4
- Handling battery pack P. 5
- Handling adapters and desktop holder P. 5
- Handling docomo mini UIM card P. 6
- Handling near electronic medical equipment P. 6
- Material list P. 6

Handling the handset, battery pack, adapters, desktop holder and docomo mini UIM card (general)

Danger

-  **Don't** Do not use, store or leave the equipment in locations subject to high temperatures (near a fire or heating unit, in a kotatsu, under direct sunlight, inside a vehicle on a hot day, etc.).
May cause fires, burns or bodily injury.
-  **Don't** Do not place the equipment inside cooking appliances such as microwave ovens or pressure cookers.
May cause fires, burns, bodily injury or electric shock.
-  **No disassembly** Do not attempt to disassemble or modify the equipment.
May cause fires, burns, bodily injury or electric shock.
-  **No liquids** Do not get the equipment wet with water, drinking water, pet urine, etc.
May cause fires, burns, bodily injury or electric shock.
Refer to the following for details on waterproofness.
 "Waterproof/Dustproof" on P. 9
-  **Instruction** Use only the battery packs and adapters specified by NTT DOCOMO for use with the handset.
May cause fires, burns, bodily injury or electric shock.

Warning

-  **Don't** Do not subject the equipment to strong force or impacts or throw it.
May cause fires, burns, bodily injury or electric shock.
-  **Don't** Do not allow conductive materials (such as metal objects and pencil lead) to come into contact with the charger terminal, external connector terminal or earphone/microphone terminal. In addition, do not insert such objects.
May cause fires, burns, bodily injury or electric shock.
-  **Don't** Do not cover or wrap the equipment with bedding etc. when using or charging.
May cause fires or burns.
-  **Instruction** Be sure to turn off the handset and not to charge the battery in locations such as gas stations where flammable gas is generated.
May cause a gas explosion or fire.
To use Osaifu-Keitai in locations such as gas stations, be sure to turn off the power in advance (If NFC/Osaifu-Keitai lock is set, disable the lock before turning off the power).
-  **Instruction** If you notice anything unusual, such as an unusual odor, overheating, discoloration or deformation during use, charging or storage, immediately follow the instructions below.
 - Unplug the power plug from the outlet or cigarette lighter socket.
 - Turn off the handset.
 - Remove the battery pack from the handset.
 May cause fires, burns, bodily injury or electric shock.

Caution



Don't

Do not leave the equipment on unstable surfaces, such as on a wobbly table or sloped surface.
May fall and cause injury.



Don't

Do not store the equipment in locations that are subject to humidity, dust or high temperatures.
May cause fires, burns or electric shock.



Instruction

If being used by a child, have a guardian teach him/her the proper handling procedures. In addition, check that the child is using the equipment as directed.
May result in bodily injury etc.



Instruction

Keep the equipment out of the reach of young children.
A young child may swallow the equipment or suffer bodily injury etc.



Instruction

Be very careful when using the handset connected to adapters repeatedly or for long periods of time.
The handset, battery pack or adapters may become warm if 1Seg etc. is used for a long time while charging. Touching high temperature areas for a prolonged period of time may cause skin irritations, itchiness or low-temperature burns in some people.



Instruction

Turn off the handset in areas where the use of mobile phones is prohibited, such as in aircraft or hospitals.

May interfere with the operation of electronic devices and electronic medical equipment.
Follow the instructions given by the respective medical facilities regarding the use of mobile phones on their premises.
Actions such as using a mobile phone aboard aircraft are prohibited and punishable by law.
However, follow the instructions on use of the handset given by the airline if the handset can be used aboard aircraft by setting the handset not to emit radio wave etc.



Instruction

Keep the handset away from the ears during a call in which hands-free is set or while the ringtone is ringing.
When you attach the earphone/microphone etc. to the handset to play games, music, etc., do not make the volume too loud.

Excessively high volume may damage your hearing. Also, it may prevent you from hearing ambient sounds and cause an accident.



Instruction

If you have a weak heart, take extra precautions when setting functions such as the vibrator and ringtone volume for incoming calls.
May have harmful effects on your heart.



Instruction

If you are using electronic medical equipment, contact the respective manufacturer or dealer to check whether the operation of the equipment is affected by signals.
May interfere with the operation of electronic medical equipment etc.



Instruction

Turn off the handset near high-precision electronic devices or devices that use weak electronic signals.

May interfere with the operation of electronic devices.
Take particular care with the following devices
Hearing aids, implanted cardiac pacemakers, implanted cardioverter-defibrillators or other electronic medical equipment. Fire alarms, automatic doors, and other equipment controlled by electronic signals. If you use an implanted cardiac pacemaker, implanted cardioverter-defibrillator or other electronic medical equipment, contact the respective manufacturer or dealer to check whether the operation of the equipment is affected by signals.



Instruction

If the display part or camera lens is damaged, be careful of broken glass and the exposed inside of the handset.

Tape is pasted on the back of the display while the surface of the camera lens is covered by a plastic panel so as to minimize the possibility of glass scattering. However, touching the broken or exposed parts may cause bodily injury.

Handling the handset

Warning



Don't

Do not aim the infrared port towards the eyes.
May cause eye injury.



Don't

Do not aim the infrared port towards home electric appliances with an infrared device during infrared communication.
May interfere with the operation of infrared devices and cause an accident.



Don't

Do not point the illuminated light directly at someone's eyes. Especially when you shoot still pictures or videos of young children, keep 1 m or more distance from them.
Do not use Mobile light near people's faces. Eyesight may be temporarily affected leading to accidents.



Don't

Do not allow water or other liquids, metal, flammable material or other foreign objects to enter the docomo mini UIM card slot or microSD Card slot on the handset.
May cause fires, burns, bodily injury or electric shock.



Don't

Do not shine the light at anyone driving a car or other vehicles.
May prevent a driver from driving safely and cause a traffic accident.

Caution



Don't

Do not swing the handset by its strap etc.
May hit you or others around you, resulting in bodily injury.



Don't

Do not use a damaged handset.
May cause fires, burns, bodily injury or electric shock.



Don't

For using a motion sensor and geomagnetic sensor, check the safety around, hold the handset and do not swing them more than necessary.
May cause injury etc.



If the display is broken and the liquid crystal then leaks, do not get the liquid on your skin (face, hands, etc.).

May result in loss of eyesight or harm to your skin.
If the liquid comes into contact with your eyes or mouth, immediately rinse your eyes or mouth with clean water and see a doctor.
If the liquid comes into contact with your skin or clothes, immediately wipe it off with alcohol, and wash with water and soap.



Instruction

If you use the handset in a vehicle, contact the vehicle manufacturer or dealer to check whether the operation of the vehicle is affected by signals.
May interfere with the operation of electronic equipment in some vehicle models. In this case, stop using the handset.



Instruction

Use of the handset may cause skin irritations such as itchiness, rashes or eczema in some people. If this occurs, immediately stop using the handset and seek medical treatment.

For details on materials of each part "Material list" on P. 6



Instruction

Look at the display in a well-lit place, keeping a certain distance from the screen.
Otherwise, eyesight may be weakened.

Handling battery pack

Check the type of battery using the information printed on the battery pack label.

Label	Battery type
Li-ion00	Lithium-ion

Danger



Don't

Do not touch terminals with metallic objects such as wires. In addition, do not carry or store the battery pack with metallic necklaces etc.

The battery pack may catch fire, explode, overheat or leak.



Don't

Check that the battery pack is facing the correct direction before you attach it to the handset. If you are having difficulty fitting the battery pack to the handset, do not use excessive pressure to force the battery into place.

The battery pack may catch fire, explode, overheat or leak.



Don't

Do not throw the battery pack into a fire.

The battery pack may catch fire, explode, overheat or leak.



Don't

Do not puncture, hit with a hammer or step on the battery pack.

The battery pack may catch fire, explode, overheat or leak.



Instruction

If the battery fluid etc. comes into contact with your eyes, do not rub your eyes but immediately rinse your eyes with clean water. Then seek prompt medical treatment.

May result in loss of eyesight.

Warning



Don't

If any trouble such as a deformation or scratches caused by dropping the battery pack is found, never use it.

The battery pack may catch fire, explode, overheat or leak.



Instruction

If the battery pack leaks or emits an unusual odor, immediately stop using it and move it away from any naked flames or fire.

The battery fluid is flammable and could ignite, causing a fire or explosion.



Instruction

Do not allow a pet to bite the battery pack.

The battery pack may catch fire, explode, overheat or leak.

Caution



Don't

Do not dispose of used battery packs in ordinary garbage.

May cause fires or damage to the environment. Place tape over the terminals to insulate unnecessary battery packs, and take them to a docomo Shop, retailer or institution that handles used batteries in your area.



Don't

Do not use or charge a wet battery pack.

The battery pack may catch fire, explode, overheat or leak.



Instruction

If the battery fluid etc. leaks, do not get the liquid on your skin (face, hands, etc.).

May result in loss of eyesight or harm to your skin.
If the liquid comes into contact with your eyes, mouth, skin or clothes, immediately rinse them with clean water.
If the liquid etc. comes into contact with your eyes or mouth, see a doctor immediately after rinsing your eyes or mouth.

Handling adapters and desktop holder

Warning



Don't

Do not use if the cord of the adapter is damaged.

May cause fires, burns or electric shock.



Don't

Never use the AC adapter or the desktop holder in humid locations such as a bathroom.

May cause fires, burns or electric shock.



Don't

The DC adapter should only be used in negative grounded vehicles. Never use it in positive grounded vehicles.

May cause fires, burns or electric shock.



Don't

Do not touch adapters if you hear thunder.

May cause electric shock.



Don't

Take care not to short-circuit the charger terminal when connected to an outlet or cigarette lighter socket. Also, take care not to allow any part of your body (hands, fingers, etc.) to come into contact with the charger terminal.

May cause fires, burns or electric shock.



Don't

Do not place heavy objects on the cord of the adapter.

May cause fires, burns or electric shock.



Don't

When plugging/unplugging the AC adapter into/ from the outlet, do not allow metallic straps or other metallic objects to come into contact with the prongs of the plug.

May cause fires, burns or electric shock.



Don't

Never try to charge the battery when the handset is wet.

The adapter and desktop holder are not waterproof. May cause electric shock, short circuit, etc. and lead to a malfunction, fires or burns.



No wet hands

Do not handle the cord of the adapters, the desktop holder or the outlet with wet hands.

May cause fires, burns or electric shock.



Instruction

Always use the specified power supply and voltage.

When using overseas, use the AC adapter that is available overseas.

Using the incorrect voltage may cause fires, burns or electric shock.

AC adapter: 100V AC

DC adapter: 12/24V DC (for negative grounded vehicles only)

AC adapter available overseas: 100 to 240V AC (Connect only with a household AC outlet)



Instruction

If the fuse in the DC adapter blows, always replace it with a fuse of the specified type.

May cause fires, burns or electric shock. Refer to the respective manuals for information on the correct fuse specifications.



Instruction

Wipe off any dust on the power plug.

May cause fires, burns or electric shock.



Instruction

Fully plug the AC adapter into the outlet.

May cause fires, burns or electric shock.



Instruction

Always grasp the adapters when unplugging the power plug from the outlet or cigarette lighter socket. Do not forcibly pull by the cord of the adapter.

May cause fires, burns or electric shock.



Unplug

Unplug the power plug from the outlet or cigarette lighter socket when not using for a long time.

May cause fires, burns or electric shock.



Unplug

Should water or other liquids enter the equipment, remove the power plug from the outlet or cigarette lighter socket immediately.

May cause fires, burns or electric shock.



Unplug

Always unplug the power plug from the outlet or cigarette lighter socket before cleaning the equipment.

May cause fires, burns or electric shock.

Handling docomo mini UIM card

Caution



Instruction

Be careful with the cutting surface when removing the docomo mini UIM card.

May cause bodily injury.

Handling near electronic medical equipment

Warning



Instruction

If you have electronic medical equipment such as an implanted cardiac pacemaker or an implanted cardioverter-defibrillator, always carry or use your handset at least 15 cm away from your implant.

Electromagnetic signals may have harmful effects on the operation of the electronic medical equipment.



Instruction

Patients receiving medical treatment away from a hospital or medical facility (e.g. home treatment) who are using electronic medical equipment other than implanted cardiac pacemakers or implanted cardioverter-defibrillators should consult the respective manufacturers for information regarding the effects of signals on the equipment.

Electromagnetic signals may have harmful effects on the operation of the electronic medical equipment.



Instruction

If there is any chance that the distance between the handset and a person closest to you may get shorter than 15 cm such as when you cannot freely move around, set the handset not to emit radio wave in advance (by setting Airplane mode, turning the power off, etc.).

Somebody nearby may be equipped with electronic medical equipment such as an implanted cardiac pacemaker or an implanted cardioverter-defibrillator. Electromagnetic signals may have harmful effects on the operation of the electronic medical equipment.



Instruction

Follow the instructions given by the respective medical facilities regarding the use of the handset on their premises.

Material list

Handset

Part	Material/Surface treatment
Display side	Reinforced glass
Surrounding area of display side	PC-ABS resin/UV coating for surface
Sides	PA resin/UV coating for surface
Upper part	PC resin/UV coating for surface
Lower part	PC resin/UV coating for surface
Side key	PC resin/UV coating for surface
Power key	ABS resin/UV coating for surface
External connector terminal	Copper alloy/Gold plating over Pd-Ni
External connector terminal cover	PC resin/UV coating for surface, Discontinuous deposition
Gasket of external connector terminal cover	Silicon rubber
Charger terminal	SUS/Gold plating
Earphone/Microphone terminal	Copper alloy/Gold plating

Part	Material/Surface treatment
Surrounding area of earphone/microphone terminal	ABS resin/UV coating for surface
Camera panel	PMMA resin
Mobile light	ABS resin
Surrounding area of out-microphone	Polyurethane
Speaker mesh	PE
Surrounding area of speaker mesh	PE
Back of display side	PA resin
Back of display side (antenna)	PC resin/UV coating for surface
Resin section of docomo mini UIM card/microSD Card slot	ABS resin
Board section of docomo mini UIM card slot	Glass epoxy board/Gold plating
Metal section of docomo mini UIM card slot	SUS/Ni plating
Lever of docomo mini UIM card slot	Nylon 46
Board section of microSD Card slot	Glass epoxy board/Gold plating
Metal section of microSD Card slot	SUS/Ni plating
Jack sheet	PET
Battery terminal	Copper alloy/Gold plating
Battery storage side	Glass epoxy board/Gold plating, PET
Resin section of battery storage side	ABS resin
Gasket of surrounding section of battery storage side	Silicon rubber
Screw	SUS/EPDM rubber

Back cover

Part	Material/Surface treatment
Back cover	PC resin/UV coating for surface

Battery pack

Part	Material/Surface treatment
Battery pack	PC resin/Spark erosion
Battery pack terminal section	Copper alloy/Full surface Ni with plating base, Gold plating

Desktop holder

Part	Material/Surface treatment
Upper side case of main body	ABS
Lower side case of main body	ABS, PLA
Tab	POM
Switch	POM
Charger terminal	C5191W-H/Gold plating, Sealing treatment
Metal section of connector terminal	Stainless steel
Screw	SWCH/Black Ni plating
Stopper	PORON

Handling precautions

General notes

- **SH-07E is waterproof/dustproof, however, do not allow water or dust to get inside the handset and do not allow accessories or optional parts to get wet or do not allow dust to adhere.**

The battery pack, adapter, desktop holder and docomo mini UIM card are not waterproof/dustproof. Do not use in humid or steamy areas such as bathrooms and avoid exposing to rain and other forms of moisture. If they are carried close to the skin, perspiration may cause internal components to corrode and result in malfunction. Note that if a problem is found to be due to moisture, the handset and parts are not covered by warranty and in some cases may be irreparable. Even when repairs are possible, repair charges will be incurred, since the damage is not covered by warranty.

- **Clean only with a soft and dry cloth (such as the type used for eyeglasses).**
 - Forceful rubbing of the LCD with a dry cloth may scratch its surface.
 - Note also that LCD coating may stain if moisture or soiling is left on the surface for a long period.
 - Never use chemicals such as alcohol, thinners, benzene or detergents, as these agents may erase the printing or cause discoloration.
- **Occasionally clean terminals with a dry cotton swab etc.** Dirty terminals may result in poor connections and loss of power or insufficient battery charge. Keep the terminals clean with a dry cotton swab etc. Be careful with the terminals while cleaning them.
- **Do not place the equipment near an air conditioning vent.** Condensation formed due to rapid changes in temperature may cause internal corrosion and lead to a malfunction.
- **Do not apply excessive force to the handset, battery pack, etc. when using it.** Carrying the handset in a tightly packed bag or sitting on the handset in your pocket may cause damage to the display, internal components, battery pack, etc. or result in a malfunction. Keeping an external connector device plugged into the external connector terminal or earphone/microphone terminal may cause damage to the connector or result in a malfunction.
- **Do not rub or scratch the display with metal etc.** May scratch it and cause malfunction or damage.
- **Read the respective manuals or user's guides supplied with the optional parts carefully.**

Notes about the handset

- **Do not forcefully press the surface of the touch panel or operate with a pointed object such as a fingernail, ballpoint pen or pin.** May damage the touch panel.
- **Avoid using the handset in extremely high or low temperatures.** Use the handset within the range of a temperature between 5°C and 35°C and a humidity between 45% and 85%.
- **Using the handset close to land-line phones, TVs, radios, etc. may have harmful effects on the operation of such equipment. Move as far away as possible from such items before use.**
- **Keep a separate memo noting information stored in the handset.** DOCOMO shall not be liable for any loss of content.
- **Do not drop or otherwise subject the handset to severe impact.** May damage the handset or cause a malfunction.

- When connecting an external connector device to the external connector terminal or earphone/microphone terminal, do not put it in obliquely and do not pull it while it is plugged in.
May damage the handset or cause a malfunction.
- The handset becomes warm during use or charging but this is not a malfunction.
- Do not leave the camera in direct sunlight.
May cause discoloration or burn-in of pixels.
- Use the handset with the external connector terminal cover closed.
Dust, water, etc. may get in and cause a malfunction.
- Do not use the handset without the back cover.
May let the battery pack come off or cause a malfunction or damage.
- While using a microSD Card, do not remove the card or turn off the handset.
May cause data loss or a malfunction.
- Never place a magnetic card near the handset.
The stored magnetic data in cash cards, credit cards, telephone cards, floppy disks, etc. may be erased.
- Never place magnetized items near the handset.
Putting highly magnetized items closer may cause an error.

Notes about the battery pack

- The battery pack is a consumable product.
Though the battery life varies with use, change the battery if the battery life is extremely short even after being fully charged. Purchase a specified new battery pack.
- Charge battery in areas where ambient temperature is between 5°C and 35°C.
- The battery life depends on the usage and deterioration of the battery.
- Depending on usage, the battery pack may swell as it approaches the end of its usable life, but this will not cause problems.
- Avoid the following situations when the battery pack is stored.
 - Storage with the battery pack fully charged (immediately after charging is completed)
 - Storage with no battery level (cannot turn the main body on)
 May lower the performance or shorten the usable life of the battery pack.
Approximately 40% is recommended as the proper battery level for storage.

Notes about adapters

- Charge the battery in areas where the ambient temperature is between 5°C and 35°C.
- Do not charge the battery pack in the following locations.
 - Areas with high humidity or dust, or in areas exposed to frequent vibrations
 - Close to land-line phones, TVs, radios, etc.
- Adapters may become warm during charging but this is not a malfunction.
- Do not use the DC adapter to charge the battery when the car engine is not running.
May cause the car battery to run down.
- When using an outlet with a feature to prevent the plug from being removed accidentally, follow the instructions in the outlet user's guide.
- Do not subject to strong force or impacts. Also, do not deform the charger terminals.
May cause a malfunction.

Notes about docomo mini UIM card

- Do not apply unnecessary force when inserting/removing the docomo mini UIM card.

- Customer is responsible for malfunctions arising from inserting docomo mini UIM card into a different IC card reader/writer etc.
- Always keep IC area clean.
- Clean only with a soft and dry cloth (such as the type used for eyeglasses).
- Keep a separate memo and note information stored on the docomo mini UIM card.
DOCOMO shall not be liable for any loss of content.
- To protect the environment, please take any unneeded docomo mini UIM cards to a sales outlet such as a docomo Shop.
- Do not damage, touch haphazardly or short-circuit the IC.
May cause data loss or a malfunction.
- Do not drop or otherwise subject the docomo mini UIM card to severe impact.
May cause a malfunction.
- Never bend the docomo mini UIM card or place heavy objects on it.
May cause a malfunction.
- Do not insert the docomo mini UIM card to the handset with a label or sticker attached on the card.
May cause a malfunction.

Notes on using Bluetooth function

- The handset supports the security function that meets the Bluetooth specification for security during communication using Bluetooth functions. However, the security may not be sufficient depending on the configuration etc. Take care of the security while making communication using Bluetooth function.
- Even if any leak of data or information occurs while making communication using Bluetooth function, DOCOMO shall not be liable for any loss of content.
- Radio frequencies
In the home screen, [📶] ▶ [Settings] ▶ [Device info] ▶ [Authentication] to confirm the radio frequencies the Bluetooth function of the handset uses. The followings are the descriptions:



- ① 2.4: This radio equipment uses the 2400 MHz band.
 - ② FH: The modulation system is the FH-SS system.
 - ③ 1: The estimated coverage distance is 10 m or less.
 - ④ XX: Another modulation system is used.
 - ⑤ 4: The estimated coverage distance is 40 m or less.
 - ⑥ : : : : : All radio frequencies between 2400 MHz and 2483.5 MHz are used and the frequencies for mobile object identifiers shall not be avoided.
- Cautions on using Bluetooth devices
Bluetooth operates at radio frequencies assigned to the in-house radio stations for a mobile object identifier that have to be licensed and is used in production lines of a factory, specific unlicensed low power radio stations, and amateur radio stations (hereafter, referred to as "another radio station") in addition to industrial, scientific and medical devices or home electric appliances such as microwave ovens.
 1. Before using the handset, make sure that "another radio station" is not operating nearby.
 2. If radio interference between the handset and "another radio station" occurs, avoid interference by moving immediately to another place or "turning off the power".
 3. Contact the number listed in "General Inquiries" on the last page for further details.

Notes about wireless LAN (WLAN)

- **Wireless LAN (WLAN) uses radio waves to communicate information.** Therefore, it has an advantage of freely connecting to the LAN within the service area. On the other hand, if security setting is not set, it is possible for a malicious third party to intercept the communication contents or hack. It is recommended to set security setting at your own risk and judgement.

- **Wireless LAN**

Do not use wireless LAN near magnetic devices such as electric appliances or AV/OA devices or in radio waves.

- Magnetism or radio waves may increase noises or disable communications (especially when using a microwave oven).
- When used near TV, radio, etc., reception interference may occur or channels on the TV screen may be disturbed.
- If there are multiple wireless LAN access points nearby and the same channel is used, search may not work correctly.

- **Radio frequencies**

In the home screen, [Ⓜ] ▶ [Settings] ▶ [Device info] ▶ [Authentication] to confirm the radio frequencies the WLAN-installed devices use. The followings are the descriptions:

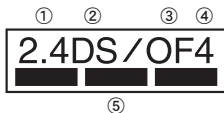

- ① 2.4: This radio equipment uses the 2400 MHz band.
- ② DS: The modulation system is the DS-SS system.
- ③ OF: The modulation system is the OFDM system.
- ④ 4: The estimated coverage distance is 40 m or less.
- ⑤ [] : All radio frequencies between 2400 MHz and 2483.5 MHz are used and the frequencies for mobile object identifiers shall be avoided.

Available channels for the handset's wireless LAN are between 1 to 13. Note that other channel access points cannot be connected.

Available channels may vary depending on the country.

For use in an aircraft, contact the airline beforehand.

- **Cautions on using 2.4 GHz devices**

WLAN-installed devices operate at radio frequencies assigned to the in-house radio stations for a mobile object identifier (radio stations requiring a license) used in production lines of a factory, specific unlicensed low power radio stations (radio stations requiring no license), and amateur radio stations (radio stations requiring a license) in addition to industrial, scientific and medical devices or home electric appliances such as microwave ovens.

1. Before using this device, make sure that the in-house radio stations for a mobile object identifier, specific unlicensed low power radio stations and amateur radio stations are not operating nearby.
2. If the device causes harmful radio interference to the in-house radio stations for a mobile object identifier, immediately change the radio frequency or stop use, and contact the number listed in "General Inquiries" on the last page for crosstalk avoidance, etc. (e.g. partition setup).
3. If the device causes radio interference to specific unlicensed low power radio stations for a mobile object identifier or amateur radio stations, contact the number listed in "General Inquiries" on the last page for further details.

- **Cautions on using 5 GHz devices**

In the 5 GHz frequency band, three bands of 5.2 GHz/5.3 GHz/5.6 GHz band (W52/W53/W56) are available.

- W52 (5.2 GHz band/36, 40, 44, 48 ch)
- W53 (5.3 GHz band/52, 56, 60, 64 ch)

- W56 (5.6 GHz band/100, 104, 108, 112, 116, 120, 124, 128, 132, 136, 140 ch)

Using 5.2 GHz/5.3 GHz band wireless LAN (W52/W53) outdoors is prohibited by the Radio Law.

FeliCa reader/writer

- The FeliCa reader/writer function in the handset uses weak radio waves whose handling does not require a license of radio station.
- The frequency in use is the 13.56 MHz band. When another reader/writer is being used nearby, keep enough distance from it. Make sure that there is no radio station using the same frequency band in the nearby area.

Caution

- **Never use the handset that is modified. Using a modified device violates the Radio Law and/or the Telecommunications Business Law.**

The handset has acquired the certification of conformity with technical regulations for the specified radio station based on the Radio Law and authentication of conformity with technical regulations for the handset based on the Telecommunications Business Law, and the "Technical Conformity Mark" can be displayed on the electronic nameplate of the handset as a proof. You can see it by operating as follows.

In the home screen, [Ⓜ] ▶ [Settings] ▶ [Device info] ▶ [Authentication] If the screws of handset are removed and a modification is given to the inside, the certification of conformity with technical regulations will become invalid. Never use the handset without the valid certification. Doing so violates the Radio Law and/or the Telecommunications Business Law.

- **Be careful when using the handset while driving a motor vehicle.**

Using a mobile phone in hand while driving is regarded as a punishable act.

However, the punishment has no application in some cases such as when rescuing sick and injured people or maintaining public safety.

- **Use the FeliCa reader/writer function only in Japan.**

The FeliCa reader/writer function in the handset conforms to the domestic radio wave standards. Using the function overseas may result in punishment.

- **Never change the basic software improperly.**

This may be regarded as a conversion of software and repairs may be refused.

- **Be careful not to connect the handset to a PC using Micro USB Cable 01 (sold separately) in areas where the use of mobile phones is prohibited.**

Power may automatically turn on.

Waterproof/Dustproof

SH-07E is waterproof to IPX5^{*1} and IPX7^{*2} standards, and dustproof to IP5X^{*3} standard if the external connector terminal cover is securely closed as well as the back cover is attached.

*1 IPX5 means that phone keeps functioning after being subjected to a jet flow (approximately 12.5 liters/min) discharged from a nozzle (inner diameter: 6.3 mm), from all directions (approximately 3 m from the handset) for 3 minutes or more.

*2 IPX7 means that SH-07E phone keeps functioning after it is slowly submerged to depth of 1 m in static tap water at room temperature, left there for approximately 30 minutes and then taken out.

*3 IP5X means the level of dust protection. Phone keeps functioning in safety after it is left in the device containing dust (diameter: 75 μm or smaller) for 8 hours, agitated and then taken out.

Before Using the Handset

Part names and functions

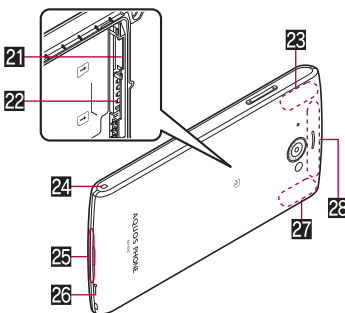
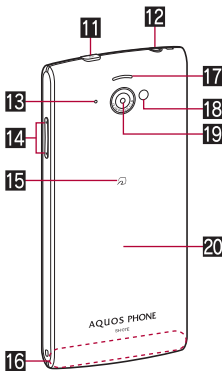
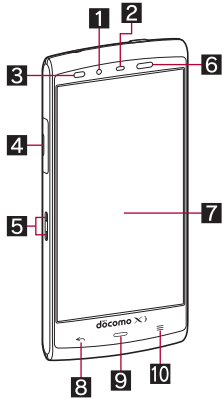

1 In-camera

2 Earpiece

3 Proximity sensor/Brightness sensor^{*1}

- The proximity sensor detects the distance to the face and prevents inadvertent operation of touch panel during a call.
- The brightness sensor detects the brightness of the surrounding area and adjusts the brightness of the backlight.

4 External connector terminal^{*2}

5 Charger terminal

- Use for charging with the included desktop holder.

6 Infrared port

7 Display/Touch panel

8 Back key

- Returns to the previous screen.

9 Home key

- Displays the home screen.

10 Menu key

- Displays available functions (menus).

11 Power key

- Use to turn the power on/off, etc.
- Use to turn the display on/off.

12 Earphone/Microphone terminal

13 Out-microphone

- Use as a stereo microphone for recording videos.
- Use to measure ambient noises for communicating by making your voices sound clear when using Noise suppression.

14 Volume UP/DOWN key

- Adjusts the volume in each function.

15 mark

- IC card is contained (It cannot be removed).

16 FOMA antenna^{*3}

17 Speaker

- Ringtone, music, etc. can be heard from here.
- The other party's voice can be heard from here during a hands-free call.

18 Mobile light

19 Out-camera

20 Back cover

21 microSD Card slot

22 docomo mini UIM card slot

23 GPS antenna^{*3}/Xi antenna^{*3}

24 Strap hole

- When attaching a strap, remove the back cover, put the strap through the strap hole, put it on the hook inside and attach the back cover.

25 Incoming/Charging illumination

26 Mouthpiece/Microphone

27 Wi-Fi/Bluetooth antenna^{*3}

28 1Seg antenna^{*3}

*1 Do not cover the sensor area with your hand or paste a sticker etc. on the sensor area. The sensor may not work properly.

*2 Audio output for when you watch movies or listen to music is not supported. Use the earphone/microphone terminal.

*3 The antenna is built into the main body. Covering the antenna area with your hand may influence the quality.

Earphone/Microphone terminal

- For details on the corresponding earphone/microphone, refer to the following website.

http://k-tai.sharp.co.jp/support/d/sh-07e/peripherals.html#!/earphone_support (in Japanese only)

Out-microphone

- When using functions which support the out-microphone, do not cover the hole of the out-microphone.

docomo mini UIM card

A docomo mini UIM card is an IC card that records personal information, such as phone numbers.

- You cannot make a call and use functions such as packet communication etc. without inserting a docomo mini UIM card.
- You cannot use the docomo mini UIM card with other than compatible handsets and may not be able to use a part of the website and data when you change from the UIM.

- In Japan, you cannot call to the emergency number (110, 119 or 118) without inserting a docomo mini UIM card.
- A docomo mini UIM card has a security code called PIN code (☞ P. 65).
- The handset supports only docomo mini UIM card. Change the UIM at a docomo Shop.
- Before inserting or removing the docomo mini UIM card, turn off the power, position the back facing upwards and remove the battery pack (☞ P. 14). Hold the handset securely with your both hands. After inserting or removing the docomo mini UIM card, attach the battery pack (☞ P. 14).

■ Inserting docomo mini UIM card

- 1 Securely hold the top of the handset, gently press the center of the back cover and hook the tip of a finger under the concave portion of the back cover to remove

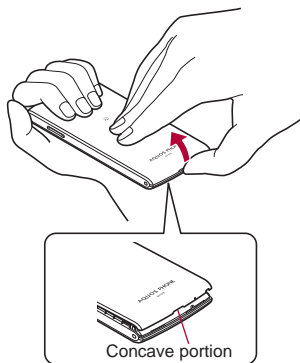

- 2 Hold the docomo mini UIM card with the IC (gold) side turned down and set it into the docomo mini UIM card slot (1)

- Push the docomo mini UIM card all the way in (2).

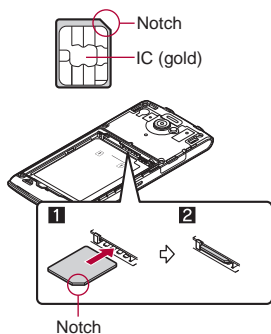

- 3 Confirm the direction of the back cover, adjust it to the direction of the handset and press the surrounding area (shaded section) of the back cover securely to attach

- Make sure there is no space between the back cover and the handset.

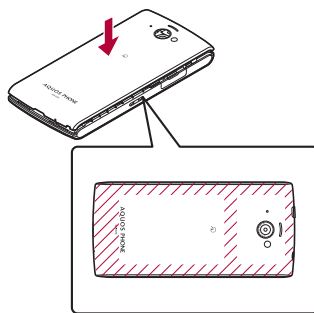

■ Removing docomo mini UIM card

- 1 Remove the back cover
- 2 Pull the lever until the docomo mini UIM card comes out (1) and pull the docomo mini UIM card straight out (2)

- Do not allow the docomo mini UIM card to fall when removing it.

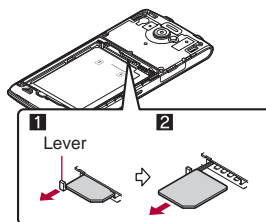

- 3 Attach the back cover

Back cover

- Securely close the back cover. If not closed securely, the back cover may come off and the battery pack may fall out due to vibration. The waterproof/dustproof performance may be impaired, resulting in allowing water or dust to get in.
- The back cover may be damaged if it is attached or removed forcibly. Be careful not to apply excessive force on it.

docomo mini UIM card

- Note that pulling forcibly or adding forces on the lever may damage it.
- Make sure not to touch or damage the IC (gold) area of the docomo mini UIM card when handling it. Also, note that inserting or removing the docomo mini UIM card forcibly may damage it.
- Refer to the docomo mini UIM card user's guide for more information on the docomo mini UIM card.
- Do not misplace the docomo mini UIM card once it is taken out.

Battery pack

- Use Battery Pack SH42 exclusive to the handset.
- Before attaching or removing the battery pack, turn off the power, position the back facing upwards and remove the back cover (☞ P. 13). Hold the handset securely with your both hands. After attaching or removing the battery pack, attach the back cover (☞ P. 13).

■ Attaching battery pack

1 Attach the battery pack

- With the recycle mark side turned up, place the connector terminal of the handset to that of the battery pack and attach the battery pack.

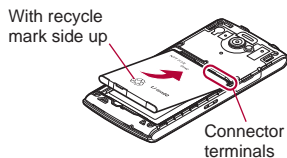

■ Removing battery pack

1 Remove the battery pack

- The battery pack has a tab that makes it easy to remove. Hook the tip of a finger on the tab to prevent excessive force on it and remove the battery pack upward.

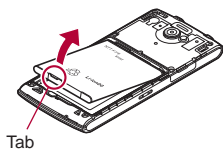

- Using unnecessary force when attaching or removing the battery pack may damage the connector terminal for the battery pack on the handset.

Charging

The battery pack is not fully charged at the time of purchase. Be sure to charge the battery before use.

- It is recommended that included Desktop Holder SH44 be used for charging to prevent water or dust from getting in caused by forgetting to close the external connector terminal cover (☞ P. 15).

■ Cautions while charging

- For details on the estimated charge time (☞ P. 87)
- The battery can also be charged with the handset turned on (While charging, the battery icon appears with [🔋] superimposed).
- Do not charge for a long time with the power left turned on. If the handset is left turned on after charging is complete, the battery pack charge level decreases. In this case, an AC or DC adapter (sold separately) charges the battery again. However, depending on the time when the handset is disconnected from the AC or DC adapter, the battery charge level may be low or the battery may only be usable for a short time.
- If the handset is left for a long time even after the charging is completed, the battery level may decrease.
- When the battery is empty and the handset is being charged, the charging illumination may not illuminate immediately. However, charging is in progress.
- If the battery empty alert is displayed and the power cannot be turned on, charge the battery for a while.
- While charging, the handset may not turn on even when the charging illumination is illuminated in red. Charge longer and try turning power on again.

- Frequently recharging the battery when its power is still remaining enough may shorten the usable life of the battery pack. It is recommended to use the battery to a certain level (e.g. after the battery level decreases) before recharging.
- When the battery becomes warm, charging may automatically stop even if the battery has not been fully charged. Charging automatically resumes after the temperature lowers to an appropriate temperature.

■ Estimated battery life when fully charged

Continuous talk time	FOMA/3G Approx. 630 min GSM Approx. 610 min
Continuous stand-by time	FOMA/3G At rest: Approx. 460 hr (Network Mode: LTE/3G/GSM (Auto)) GSM At rest: Approx. 400 hr (Network Mode: LTE/3G/GSM (Auto)) LTE At rest: Approx. 400 hr (Network Mode: LTE/3G/GSM (Auto))
Mobacas watching time	Approx. 380 min
1Seg watching time	Approx. 510 min

- For details on the battery life ☞ P. 87

■ Battery pack usable life

- Battery pack is a consumable product. Service time per charge is gradually reduced every time the battery is charged.
- When service time per charge is reduced to about half of the default time, this means that the battery pack is approaching the end of its usable life. In this case, it is recommended to replace the battery as soon as possible. Depending on usage, the battery pack may swell as it approaches the end of its usable life, but this will not cause problems.
- If you watch 1Seg etc. while charging for a long time, the usable life of the battery pack may become shorter than estimated.



Li-ion00

■ AC adapter and DC adapter

- Refer to user's guide of AC Adapter 03/04 (sold separately) or DC Adapter 03 (sold separately).
- AC Adapter 03/04 covers from 100 to 240V AC.
- The shape of the plug for the AC adapter is for 100V AC (for domestic use). To use the AC adapter of 100 to 240V AC overseas, a conversion plug adapter applicable to your country of stay is required. Do not use a voltage converter for overseas travel to charge the battery.

Charging with desktop holder

- It is recommended to use AC Adapter 04 for charging with the desktop holder.

1 Insert the microUSB plug of the AC adapter horizontally into the connector terminal of the desktop holder with the side marked with "B" turned up

- Check the direction (front or rear) of the microUSB plug and insert it horizontally.

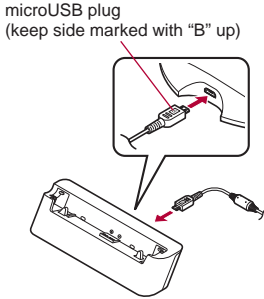

2 Erect the AC adapter power plug and insert it into an outlet

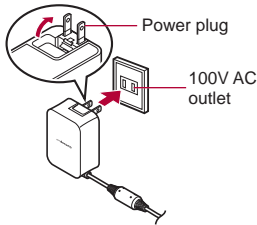

3 When placing the handset on the desktop holder, the charging illumination illuminates and charging starts

- Place the handset in the direction of the arrow so that it fits the desktop holder and make sure that a click is heard.

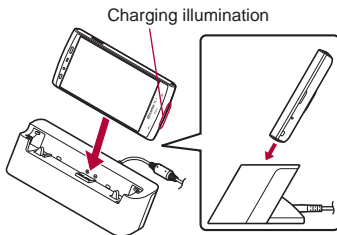

4 When charging is complete, the charging illumination turns off

- Hold the desktop holder and lift the handset after tilting it towards you.

5 Remove the AC adapter power plug from the outlet

6 Remove the microUSB plug of the AC adapter horizontally from the connector terminal of the desktop holder

- When the charging illumination does not illuminate, check that the handset is placed securely on the desktop holder.
- When placing the handset in the desktop holder, be careful not to let a strap etc. caught.
- You cannot charge the battery by connecting the desktop holder and a PC via a microUSB cable.

Charging with AC adapter/DC adapter

[Read the user's guides of AC Adapter 03/04 (sold separately) and DC Adapter 03 (sold separately)]

- Following operations describe how to charge with AC Adapter 04 or DC Adapter 03.

1 Open the external connector terminal cover of the handset

- Hook the tip of a finger under the concave portion to open.

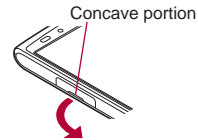

2 Insert the microUSB plug of the AC adapter/DC adapter horizontally into the external connector terminal on the handset with the side marked with "B" turned up

- Check the direction (front or rear) of the microUSB plug and insert it horizontally.

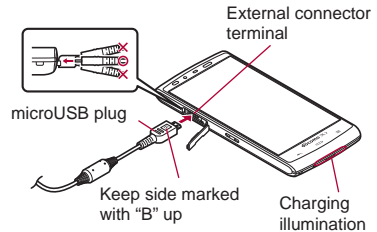

3 When you erect the AC adapter power plug and insert it into an outlet or insert the DC adapter power plug into a car cigarette lighter socket, the charging illumination illuminates and charging starts

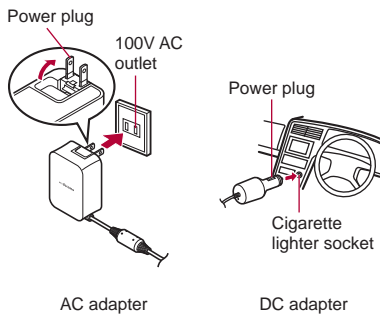

4 When charging is complete, the charging illumination turns off

5 Remove the AC adapter power plug from the outlet, or remove the DC adapter power plug from the car cigarette lighter socket

6 Remove the microUSB plug of the AC adapter/ DC adapter horizontally from the external connector terminal

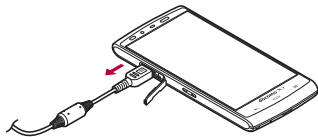

7 Close the external connector terminal cover of the handset

- Stow the joint of the external connector terminal cover (1) and push the cover in the direction of the arrow to close it so that gaps are not left between the handset and the cover (2).

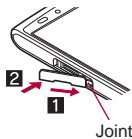

- Do not forcibly insert or remove. May cause damage to the external connector terminal and the microUSB plug or result in a malfunction.
- Do not forcibly pull the external connector terminal cover. May damage the cover.
- Do not place objects near the handset when charging. May damage the handset.

When using a DC adapter

- The DC adapter should only be used in negative grounded vehicles (12 and 24V DC).
- Do not use with the car engine shut off. May drain the car battery.
- The DC adapter fuse is a consumable product. For replacement, purchase a new fuse at a nearest auto parts retailer etc.
- Refer to the user's guide of DC Adapter 03 for details.

Charging with Micro USB Cable 01

When the handset is turned on, you can charge the handset by connecting the handset to a PC with Micro USB Cable 01 (sold separately).

- For details on connecting to a PC P. 75

Turning power on/off

Turning power on

1 (for at least 2 seconds)

- When you turn the power on for the first time, the initial setting screen is displayed. Each setting item can also be set from menus (P. 21).
- If the initial setting screen for docomo service is displayed, operate by following the instructions on the screen.

Turning power off

1 (for at least 1 second) ▶ [Power off completely] ▶ [OK]

Turning power off forcibly

You can forcibly turn the power off if the screen does not respond or the power cannot be turned off.

1 (for at least 11 seconds)

- The power is turned off after the vibrator activates twice.

- The handset restarts if you release your finger from during the interval of the two vibrations.

Sleep mode

You can quickly activate the handset when turning the power on again by setting the sleep mode.

1 (for at least 1 second) ▶ [To sleep] ▶ [OK]

- Do not set the sleep mode but turn the power off when an airplane you are aboard is about to take off/land, the battery level is low, etc.
- Even if you set the sleep mode, the handset may not be quickly activated depending on its status such as when it has not been used for a long time.

Turning display on/off

The screen is off when is pressed or the handset is not in use for a set length of time.

Press while the display is turned off to turn it on.

Touch panel lock

When the power or the display is turned on, the touch panel is locked.

Touch to unlock.

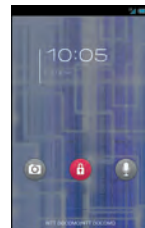

Operations in touch panel unlock screen

- To set/disable the manner mode: (for at least 1 second)

Setting an access point

The access point (sp-mode and mopera U) for Internet connection is registered by default. You can add or change it if necessary.

At the time of purchase, an access point of sp-mode is set for usual connection.

Checking an access point in use

- 1 In the home screen, [☰] ▶ [Settings] ▶ [More...] ▶ [Mobile networks] ▶ [Access Point Names]

Setting additional access points

- Never set the MCC to other than 440 and the MNC to other than 10. They do not appear on the screen.

- 1 In the home screen, [☰] ▶ [Settings] ▶ [More...] ▶ [Mobile networks] ▶ [Access Point Names] ▶ [≡] ▶ [New APN]
- 2 [Name] ▶ enter the name of the network profile to create ▶ [OK]
- 3 [APN] ▶ enter the access point name ▶ [OK]
- 4 Enter other items required by network operators ▶ [≡] ▶ [Save]

- If the settings of MCC and MNC are changed and they do not appear on the screen, reset the settings or set the access point manually.

Resetting an access point

Reset an access point to default setting.

- 1 In the home screen, [☰] ▶ [Settings] ▶ [More...] ▶ [Mobile networks] ▶ [Access Point Names] ▶ [≡] ▶ [Reset to default]

- When sp-mode is not subscribed or if you failed to make automatic setting of access point due to signal status such as outside the service area, you are required to set the access point again manually.

sp-mode

sp-mode is an ISP owned by NTT DOCOMO for the Smartphone. In addition to the Internet connection, mail service with the same address you use on i-mode (@docomo.ne.jp) or other services are available. sp-mode is a paid service that requires subscription. For details on sp-mode, refer to the DOCOMO website.

mopera U

mopera U is an ISP owned by NTT DOCOMO. If you subscribe to mopera U, you can use Internet with simple setting. mopera U is a paid service that requires subscription.

Setting mopera U

- 1 In the home screen, [☰] ▶ [Settings] ▶ [More...] ▶ [Mobile networks] ▶ [Access Point Names] ▶ [mopera U]/[mopera U 設定] (mopera U settings)

- mopera U 設定 (mopera U settings) is an access point for mopera U settings. When you use the access point for mopera U settings, packet communication charges are not incurred. Note that you can connect to only the initial setting screen or the change setting screen. For details on mopera U settings, refer to the mopera U website.

Wi-Fi settings

If you use Wi-Fi function of the handset, you can use mail or Internet by connecting to your home, corporate network or access points of public wireless LAN service.

The radio interference with Bluetooth devices

- Wireless LANs (IEEE 802.11b/g/n) use the same frequency band (2.4 GHz) as Bluetooth devices. Therefore, using the wireless LAN device near a Bluetooth device may cause radio interference, lowering of communication speed, noise or connection failure. In this case, turn off the Bluetooth device or keep the handset and the wireless LAN device at least approximately 10 m away from the Bluetooth device.
- Packet communication is also available while Wi-Fi is set to [ON]. Wi-Fi connection is prioritized while Wi-Fi connection is set, but the connection may be automatically switched to that of LTE/3G/GPRS network once Wi-Fi connection is terminated. Note that packet communication charges may be incurred in this case.
- Refer to the manual of your wireless LAN base unit when using the access point at home etc.
- Operate access point registration near the access point.
- If you use the docomo service by using Wi-Fi function, set DOCOMO Wi-Fi option password in advance. In the home screen, [☰] ▶ [Settings] ▶ [docomo service] ▶ [Wi-Fi settings for docomo apps] to set it.

- 1 In the home screen, [☰] ▶ [Settings] ▶ [Wi-Fi]

- 2 Slide [OFF] to the right

- 3 Select an access point

- If you select an access point protected by security, enter the password (security key) and select [Connect].
- WPS compatible access points can be easily registered. In the home screen, [☰] ▶ [Settings] ▶ [Wi-Fi] ▶ [EASY SETTINGS] ▶ [WPS Push Button]/[WPS Pin Entry] to register an access point.
- To register access points manually: [ADD NETWORK] ▶ enter the network SSID ▶ set security ▶ [Save]
- Alternatively, in the home screen, [☰] ▶ [Settings] ▶ [Wi-Fi] ▶ [EASY SETTINGS] ▶ [AOSS] to connect to an access point. Follow the instructions on the screen and operate after this step.

- When you select an access point and connect to it with a wrong password (security key), [Avoided poor Internet connection], [Authentication problem] or [Connected (Limited)] is displayed. Confirm the password (security key). When [Avoided poor Internet connection] or [Connected (Limited)] is displayed after entering the correct password (security key), you may not have acquired the correct IP address. Connect to the access point again after confirming signal status.
- The registration process using WPS takes a few minutes. After completion of the registration of the access point, check that the proper connection to the access point is acquired.
- As for the manual registration of an access point, this function supports WEP, WPA/WPA2 PSK and 802.1xEAP as the security setting.

Detailed settings

1 In the home screen, [⋮] ▶ [Settings] ▶ [Wi-Fi] ▶ [≡] ▶ [Advanced]

2 Select an item

- **Network notification:** Set whether to display a notification icon when an open network is detected.
 - Set it after setting Wi-Fi to [ON].
- **Wi-Fi sleep policy:** Set when to switch the Wi-Fi function to the sleep mode.
- **Wi-Fi frequency band:** Set the frequency band to use.
- **MAC address:** Confirm the MAC address.
- **IP address:** Confirm the IP address.

Disconnecting

1 In the home screen, [⋮] ▶ [Settings] ▶ [Wi-Fi]

2 Select the connected access point ▶ [Forget]

- Disconnect with the password retained.

Tethering

Tethering function that connects Wi-Fi compatible devices or a PC connected via Micro USB Cable 01 (sold separately) to the Internet by using the handset as an access point is available.

- You can connect up to 11 devices in total at the same time: ten Wi-Fi compatible devices and a PC connected via Micro USB Cable 01.

1 In the home screen, [⋮] ▶ [Settings] ▶ [More...] ▶ [Tethering & hotspot]

2 Select an item

- **USB tethering:** Set whether to use the USB tethering.
 - Check the details of the precautions before use.
- **Wi-Fi tethering:** Set whether to use the Wi-Fi tethering.
 - Check the details of the precautions before use.
- **Set up Wi-Fi hotspot:** Make settings for the Wi-Fi tethering settings such as network SSID and security.

[USB tethering]

- The tethering function is available on Windows Vista, Windows 7, Windows 8 and Linux.
- A microSD Card inserted in the handset cannot be mounted on a PC during USB tethering.
- For details on USB tethering, refer to the following website.
<http://www.android.com/tether#usb>

[Wi-Fi tethering]

- While the handset is functioning as an access point, it cannot access the Internet via Wi-Fi connection.
- Make settings for Wi-Fi access points in [Set up Wi-Fi hotspot].
- For details on Wi-Fi tethering, refer to the following website.
<http://www.android.com/tether#wifi>

[Set up Wi-Fi hotspot]

- At the time of purchase, Network SSID is set to [SH-07E_AP] and Security is set to [WPA2 PSK] while Password is set randomly. Change the settings if necessary.

Setting up mail account

1 In the home screen, [⋮] ▶ [Email]

- Only when an account is not set, the account setting screen appears.

2 Enter mail address and password ▶ [Next]

- Provider information is preset for some mail accounts, and a receiving mail server and a sending mail server are automatically set.

- When you use an account whose provider information is not preset, it is necessary to set a receiving mail server and a sending mail server manually. For details on those settings, contact the Internet service provider you use.

3 Set an account ▶ [Next]

4 Enter an account name and your name ▶ [Next]

- The account which is registered first is automatically given priority to normal use. When registering multiple accounts, you can set an account as prioritized one by enabling [Send email from this account by default.] at the time of the registration.
- When the account type is Exchange, entering "¥UsernameDomain" in the "Domain¥Username" area may be required to set a receiving mail server manually depending on the provider to use. Contact the administrator of the server for details.

Setting up Google account etc.

1 In the home screen, [⋮] ▶ [Settings] ▶ [Add account]

2 Select the account type

3 Set up an account

- In the home screen, [⋮] ▶ [Settings] to find the added account on the displayed menu.

- When activating the app that requires an account without setting the account, the account setup screen appears.
- Keep a separate memo of the set account and password.

Deleting your account

1 In the home screen, [⋮] ▶ [Settings]

2 Select an account ▶ [≡] ▶ [Remove account] ▶ [Remove account]

- Operation methods may differ depending on the account.

Retrieving your Google account password

If you forget your Google account password, retrieve it.

1 In the home screen, [⋮] ▶ [Browser]

2 Enter "http://www.google.com/" in the URL entry field ▶ [Go] ▶ [Sign in] ▶ [Can't access your account?] ▶ follow the instructions on the screen

- If the URL entry field is hidden, slide the browser screen down.

Importing/Exporting phonebook

Importing from docomo mini UIM card

1 In the home screen, [⋮] ▶ [docomo phonebook] ▶ [Contacts]

2 [≡] ▶ [Others] ▶ [Import/Export] ▶ [Import from SIM card]

- If there are multiple accounts, the screen for selecting to which account to register is displayed.

3 Select the contact to import

- To import all contacts: [≡] ▶ [Import all]

Making a call

- In the home screen, [Phone] ▶ [Dial]**
- Enter a phone number**
 - Always enter the city code, even when it is a local number.
 - You can set to notify/not to notify the other party of your phone number for each call by adding "186"/"184" to the head of the phone number.



- Call**
 - Make a call. Also, if there is an outgoing call history, touch to enter the latest outgoing call history when the phone number has not been entered.
 - Delete**
 - Delete an entered number.
 - Touch and hold it to delete all the entered numbers.
 - Outgoing/Incoming call history**
 - Favorites**
 - Display the contacts set as favorites.
 - Dial**
 - Display the dial screen.
 - Add to phonebook**
 - Koe-no-Takuhaibin**
 - For details of Koe-no-Takuhaibin, refer to the DOCOMO website.
 - Phonebook**
 - Display the phonebook.
- [End]
 - [End] to end the call**

Entering touch-tone signals

When using services in which you are required to enter numbers additionally during a call, such as inquiry about the balance in your bank account or ticket reservation, enter pause (,) / wait (;) after entering a phone number to make a call with an additional number added to the main phone number.

Adding 2 seconds pause

After making a call to a main phone number, the handset automatically pauses for 2 seconds and an additional number is sent.

- In the home screen, [Phone] ▶ [Dial]**
- Enter a phone number ▶ [Add 2-sec pause]**
- Enter a number to send ▶ [End]**

Adding wait

After making a call to a main phone number, the handset automatically waits and then a screen asking whether to send an additional number is displayed. Touch [Yes] to send an additional number.

- In the home screen, [Phone] ▶ [Dial]**
- Enter a phone number ▶ [Add wait]**
- Enter a number to send ▶ [Yes]**
- [Yes] during the call**

Emergency call

Emergency calls	Phone number
Police	110
Fire and ambulance	119
Marine emergency	118

- The handset supports "Location notification of emergency call". When you make a call to an emergency number such as 110, 119, and 118, the information of your location (location information) is automatically notified to the agency that received the emergency call (e.g. the police station). Depending on your location and the reception status of the signal, the agency that received the emergency call may not be able to confirm the exact location. If you are not sending your caller ID by calling with "184" added or other means, your location information and phone number are not notified. However, if the agency that received the emergency call considers your location information and phone number necessary for important purposes, such as life saving, the agency can retrieve them regardless of your settings. In addition, the area/timing to introduce "Location notification of emergency call" depends on the state of preparation in each agency that receives emergency calls.
- In Japan, you cannot make a call to the emergency number (110, 119 or 118) when a docomo mini UIM card is not inserted, while the PIN code is locked or from the PUK (PIN Unlock Key) entry screen.
- When calling 110, 119, and 118 from your handset, the police or fire stations may return your call for verification purposes. State that you are calling from a mobile phone, and give your phone number and exact present location. Remain stationary to ensure that the call is not disconnected while you are on the line, and keep the handset turned on to receive calls for approximately 10 minutes afterwards.
- Depending on the region, calls to the police or fire station of the local area may not be made.
- When you make a call to the emergency number (110, 119 or 118) while Not registered in address book in Call blocking is set, Not registered in address book is set to [OFF].

International call (WORLD CALL)

WORLD CALL is an international calling service available from DOCOMO handset in Japan.

WORLD CALL is registered when FOMA services are registered (excluding users who did not apply for WORLD CALL).

- You can call to approximately 240 countries and regions worldwide. Calling to a land-line phone and mobile phone overseas is available.
- For information on countries where connections are available and available overseas network operators, refer to "Mobile Phone User's Guide [International Services]" or the DOCOMO International Services website.
- Commission and monthly usage fees are free.

- Contact the number listed in "General Inquiries" on the last page for details on WORLD CALL.
- To make an international call through a company other than DOCOMO, contact the respective companies for instructions.
- The caller ID may not be notified or displayed correctly depending on overseas network operators. In this case, making a call with incoming call history is not available.

[Calling Method]

- When calling to a land-line phone: 010 ▶ country code ▶ area code (city code) ▶ the other party's phone number ▶
- When calling to a mobile phone: 010 ▶ country code ▶ the other party's phone number ▶
- As for the other parties' phone numbers and area codes (city codes) that begin with "0", omit the first "0" when entering (except some countries or regions such as Italy).
- Alternatively, enter "009130-010" as usual or "+" instead of "010".

Receiving a call

1 When a call is received, the ringtone sounds and the incoming illumination flashes

- If you press during an incoming call, you can stop the ringtone, vibrator or flash of the incoming illumination.



Incoming illumination

2 Receive the call

- Operate after touching [Activate].

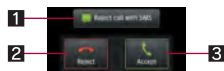

1 Reject call with SMS

- You can reject an incoming call and send a selected SMS message to the other party.

2 Reject

- You can reject the incoming call.

3 Accept

- You can receive the call.

3 [End] to end the call

Placing a call on hold

1 When a call is received, the ringtone sounds and the incoming illumination flashes

2 ▶ [On hold]

Answering by answering memo

1 When a call is received, the ringtone sounds and the incoming illumination flashes

2 ▶ [Absence Memo]

Playing an answering memo

1 In the home screen, ▶ [Phone] ▶ ▶ [Call settings]

2 [Call/Ans Memo] ▶ [Answering Memo List] ▶ select an answering memo

Operation during a call

You can carry out operations such as using a hands-free call and adjusting the in-call volume according to the using condition during a call.



1 Add call*

- Place a current call on hold and make a call to another party.

2 End

- End a call.

3 Dialpad

- You can enter touch-tone signals.

4 Hold

- Hold/Unhold a current call.
- If you have added a call, [Switch] is displayed. Touch it to switch to whom you talk.

5 Mute

- Enable or disable mute setting on a current call.

6 Speaker

- You can talk with hands-free.
- When a Bluetooth device is connected, you can switch sound emitting parts.

* Subscription to Call Waiting Service is required.

- Note the following to use hands-free.

- Speak approximately 20 to 40 cm away from the mouthpiece. When the surroundings are noisy, the sound may break up and the call may not be satisfactory.
- When calling outdoors, in a location where surroundings are noisy and where the sound echoes loudly, use an earphone/microphone.
- If the sound breaks up during a hands-free call, lower the in-call volume.

Adjusting the in-call volume

1 during a call

2 [-]/[+]

- Alternatively, press to adjust the volume.

3 [Close]

Using Noise suppression

When Noise suppression is set to [ON], you can measure ambient noises using the out-microphone and communicate by making your voices sound clear during a call.

- Noise suppression is set to [OFF] when you start talking on the handset.

1 during a call

2 [OFF]/[ON]

3 [Close]

- Noise suppression processes voices to make conversations sound clear. Sound quality may vary depending on the surrounding noises and the tone of the voice.

- When using Noise suppression, make sure not to cover the hole of the out-microphone and move the mouthpiece as close to your mouth as possible for speaking.

Deleting phonebook

Deleting all entries

- 1 In the home screen, [☰] ▶ [docomo phonebook] ▶ [Contacts]
- 2 [≡] ▶ [Delete] ▶ [Select all] ▶ [Delete] ▶ [OK]

Deleting one entry

- 1 In the home screen, [☰] ▶ [docomo phonebook] ▶ [Contacts]
- 2 Select the name ▶ [≡] ▶ [Delete] ▶ [OK]

Editing phonebook

- 1 In the home screen, [☰] ▶ [docomo phonebook] ▶ [Contacts]
- 2 Select the name ▶ [Edit]
- 3 Set each item ▶ [Save]
 - For details of each item that can be set ☞ P. 34

Using groups

- 1 In the home screen, [☰] ▶ [docomo phonebook] ▶ [Contacts] ▶ [Groups]
- 2 Use groups



- 1 Group name
- 2 Number of contacts registered in the group
- 3 Group
- 4 No group
- 5 Add
 - Add a group.
- 6 Close
 - Hide the group.
- 7 Group icon

Grouping/Ungrouping contacts

- 1 In the home screen, [☰] ▶ [docomo phonebook] ▶ [Contacts] ▶ [Groups]
- 2 Touch and hold a contact ▶ drag it to a group
 - Drag it to the group into which it has already been registered to ungroup it.

- The group function is available on contacts created with a docomo/Google account.

My profile

You can display your phone number registered on the docomo mini UIM card. You can also register your name, mail addresses, etc.

- 1 In the home screen, [☰] ▶ [docomo phonebook] ▶ [My profile]
- 2 Check/Use the profile

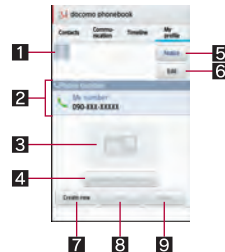

- 1 Image
- 2 Registered contents
- 3 Business card
 - Display the created business card.
- 4 Exchange this name card
 - Exchange the registered business cards via a network.
- 5 Create new
 - Create a business card.
 - Download the “Name card creator” app to create a business card. Follow the instructions on the screen and operate after this step.
- 6 Notice
 - Make settings for Friends notice.
- 7 Edit
- 8 Delete business card
- 9 Edit business card
 - Edit the business card with the “Name card creator” app.

Editing My profile

- 1 In the home screen, [☰] ▶ [docomo phonebook] ▶ [My profile] ▶ [Edit]
- 2 Set each item ▶ [Save]

Backing up/Restoring phonebook

You can back up/restore the phonebook by using docomo backup (Save on the microSD Card).

- For details on docomo backup (Save on the microSD Card) ☞ P. 59

sp-mode mail

You can send and receive mails using mail address of i-mode (@docomo.ne.jp). Pictograms and Deco-mail are available. Automatic reception is also supported.

- For details on sp-mode mail, refer to “ご利用ガイドブック (spモード編)” (Mobile Phone User’s Guide [sp-mode]) (in Japanese only).

1 In the home screen, [☰] ▶ [spモードメール] (sp-mode mail)

- Follow the instructions on the screen and operate after this step.

SMS

You can send and receive text messages that include up to 70 double-byte characters (up to 160 characters for single-byte alphanumeric only) to/from other handsets using phone numbers.

- You can also exchange messages with users of overseas network operators. Refer to “Mobile Phone User’s Guide [International Services]” or the DOCOMO International Services website for information on countries where this service is available and available overseas network operators.

1 In the home screen, [☰] ▶ [Messaging]

2 [✉] ▶ enter a destination and a message ▶ [▶]

- If destinations are handsets of overseas network operators, enter “+”, the country code and the recipient’s mobile phone number. If the phone number begins with “0”, omit the first “0”. Alternatively, enter “010”, the country code and the phone number.
- Single-byte katakana and special symbols in SMS messages may not appear correctly for recipient.
- SMS cannot be sent when “186” or “184” is added.

Displaying message

1 In the home screen, [☰] ▶ [Messaging]

2 Select a thread

- Messages are grouped into a thread by destination/sender and displayed.



1 Image

- It is displayed if an image of the other party is registered in the phonebook. Touch to select and use an app supporting the registered contents of the phonebook. If the sender is not registered in the phonebook, you can register the person in the phonebook by touching it.

2 Destination/Sender

3 Number of messages in thread

4 Date and time of the message exchange

3 Check the message



1 Destination/Sender

2 Phone call

3 Date and time of the message exchange

4 Message

Replying message

1 In the home screen, [☰] ▶ [Messaging]

2 Select a thread

3 Enter the message ▶ [▶]

Forwarding message

1 In the home screen, [☰] ▶ [Messaging]

2 Select a thread

3 Touch and hold the message ▶ [Forward] ▶ enter the destination and message ▶ [▶]

Deleting message

1 In the home screen, [☰] ▶ [Messaging]

2 Select a thread

3 Touch and hold the message ▶ [Delete] ▶ [Delete]

Deleting thread

1 In the home screen, [☰] ▶ [Messaging]

- To delete all threads: [☰] ▶ [Delete all threads] ▶ [Delete]

2 Touch and hold the thread ▶ [☒] ▶ [Delete]

Setting message

1 In the home screen, [☰] ▶ [Messaging]

2 [☰] ▶ [Settings]

3 Select an item

- **Delete old messages:** When the number of saved messages reaches its limit, messages are automatically deleted from the oldest one.
- **Text message limit:** Set the number of messages to be saved by thread.
- **Delivery reports:** Notify you that sent messages have been received every time a message is received.
- **Manage SIM card messages:** Manage messages saved on the docomo mini UIM card.
- **Notifications:** Notify you that messages have been received in the status bar.

- **Sound:** Set the ringtone to be rung when a message is received.
- **Vibrate:** Set the vibrator to be activated when a message is received.

[Delivery reports]

- When you send a message to mobile phones of other carriers, the notification for confirming that it has been received may not be sent to you.

Email

You can send and receive mails by setting a mail account provided by a service provider such as mopera U.

- Set the account in advance (P. 23).

1 In the home screen, [App] ▶ [Email]

2 [✉]

3 Compose the mail

- To attach a file: [Attachment icon] ▶ [Attach file] ▶ select a file

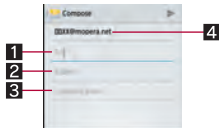

1 Destination

- When you enter part of a mail address or a name registered in the phonebook, destination candidates are displayed.

2 Subject

3 Message

4 Account

4 [▶]

- Some receiving side models may not be able to receive the subject completely.
- Mail sent from a Gmail account is treated as one from a PC. When receiving side models set PC-mail rejection, mails cannot be sent.
- Mail that could not be sent for any reason will be saved in the Outbox as unsent mail.
- Text for recipient may not appear correctly depending on signal status.

Attaching file

- A mail can include 5 MB worth of file attachments together with the message. There are no limits to the number of files to be attached.
- Depending on the receiving side handset, files may not be received or correctly displayed/played. Also, the quality of videos may deteriorate or videos may be converted to continuous still pictures.

Displaying mail

Example: When a mopera U account is set

1 In the home screen, [App] ▶ [Email]

2 Select a mail

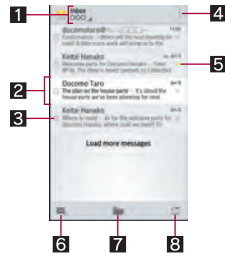

1 Folder name/Account name being displayed

- Touch to switch folders and accounts.

2 Unopened mail

- The background color of an opened mail turns gray.

3 Check box

- Apply the settings for mails to be deleted/unopened/opened/starred on the checked mails collectively.

4 Number of unopened mails

5 Star icon

- Use it as a mark indicating that the mail is special or supposed to be dealt with later.
- You can check starred mails in the Starred folder.

6 Newly compose mail

7 Display all folders

8 Refresh

3 Check the mail

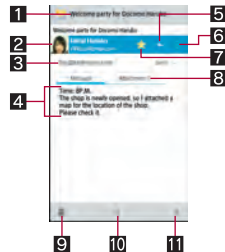

1 Subject

2 Sender

- Touch the image to select and use an app supporting the registered contents of the phonebook. If the sender is not registered in the phonebook, you can register the person in the phonebook by touching it.

3 Destination/Date and time of reception

- Touch to display the details.

4 Message

5 Reply

6 Reply all/Forward

7 Star icon

- Use it as a mark indicating that the mail is special or supposed to be dealt with later.
- You can check starred mails in the Starred folder.

8 Attached file

- Touch to display the attached file.

9 Delete

10 Unread

11 Display new mail

12 Display old mail

Replying/Forwarding mail

1 In the home screen, [⌨] ▶ [Email]

2 Select a mail

3 [↶]

- To reply to all: [⌨] ▶ [Reply all]
- To forward: [⌨] ▶ [Forward]

4 Compose the mail ▶ [▶]

Deleting mail

1 In the home screen, [⌨] ▶ [Email]

- To delete selected mails: Touch check boxes ▶ [🗑]

2 Select a mail

3 [🗑]

Setting mail

1 In the home screen, [⌨] ▶ [Email] ▶ [☰] ▶ [Settings] ▶ [General]

- Select an account to make settings for the details on each account such as Signature and Email notifications.
- Touch [ADD ACCOUNT] to add an account.

2 Select an item

- **Auto-advance:** Set a screen to be displayed after a mail is deleted.
- **Message text size:** Set the font size of mail.
- **Reply all:** Set whether to reply a mail to all when replying it.
- **Ask to show pictures:** Disable the settings to have the handset automatically display images attached on a mail.
- **Confirm before deleting:** Set whether to display the confirmation screen before deleting a mail.

Gmail

Gmail is a mail service provided by Google.

- Set up a Google account in advance (☞ P. 23).

1 In the home screen, [⌨] ▶ [Gmail]

2 [✉]

3 Compose the mail



1 Destination

- When you enter part of a mail address or a name registered in the phonebook, destination candidates are displayed.

2 Subject

3 Message

4 Account

- If you set multiple accounts, you can switch accounts.

4 [▶]

Displaying mail

1 In the home screen, [⌨] ▶ [Gmail]

2 Select a thread

- In Gmail, mails are grouped into a thread by reply and displayed. If new mails are replied ones of an existing mail, they are grouped into the same thread. New thread is created for newly composed mails or mails whose subjects have been changed.

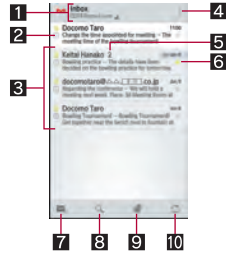

1 Label/Account name being displayed

- Touch to switch displaying type and accounts.

2 Check box

- Apply the settings for the archive/deletion/label/unopened/opened/starred, etc. on the checked mails collectively.

3 Thread with no unopened mails

- The background color is displayed in gray.

4 Number of unopened threads

5 Number of mails in thread

6 Star icon

- Use it as a mark indicating that the mail is special or supposed to be dealt with later.
- You can check starred mails in the Starred folder.

7 Newly compose mail

8 Mail search

9 Display all labels

10 Refresh

3 Check the mail

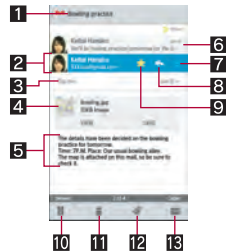

1 Subject

2 Sender

- Touch the image to select and use an app supporting the registered contents of the phonebook. If the sender is not registered in the phonebook, you can register the person in the phonebook by touching it.

3 Destination/Date and time of reception

- Touch to display the details.

4 Message

5 Attached file

6 Opened mail

- If the thread has multiple mails inside, touch to check the opened mails by displaying their senders, first lines, etc.

7 Reply all/Forward

8 Reply

- Move the Bluetooth device to a place where connection is possible when there is a broadcast station or radio near the Bluetooth device and the handset cannot be connected to the device. Strong radio waves may prevent connection between Bluetooth devices.
- Wireless connection is available with Bluetooth device put in a bag or pocket. However, lowering of communication speed or noise may result when you are in between the Bluetooth device and the handset.
- Electromagnetic signals from the Bluetooth device may affect the operation of electronic medical equipment etc. As some cases may result in accident, turn off the handset and other Bluetooth devices in the following place.
 - On trains ■ On airplanes ■ In hospitals
 - Near automatic doors or fire alarms
 - In places such as gas stations where flammable gas is generated

The radio interference with Wi-Fi compatible devices

- The Bluetooth devices use the same frequency band (2.4 GHz) as wireless LANs (IEEE 802.11b/g/n). Therefore, using the Bluetooth device near a wireless LAN device may cause the radio interference, lowering of communication speed, noise or connection failure. In this case, turn off the wireless LAN device or keep the handset and the Bluetooth device at least approximately 10 m away from the wireless LAN.

Bluetooth

- To register/connect a Bluetooth device, the Bluetooth passkey may need to be entered. Before starting the registration, decide one- to sixteen-digit number. Enter the same number on the handset and the other party's Bluetooth device.
- Set the other party's Bluetooth device to the registration stand-by status in advance.

1 In the home screen, [⌘] ▶ [Settings] ▶ [Bluetooth]

2 Slide [OFF] to the right

3 Select a Bluetooth device ▶ [Pair]

- The confirmation screen for connection may be displayed.
- Entering the Bluetooth passkey may be necessary depending on the other party's Bluetooth device. Also, some Bluetooth devices may start connecting after completing registration.
- To display/hide the handset's name on other Bluetooth devices: [SH-07E]
 - The handset name is automatically hidden when the period of time set for Visibility timeout has passed.
- To search for Bluetooth devices: [SEARCH FOR DEVICES]
- Touch [↗] of a paired Bluetooth device to change the name and the connection type of the other party's Bluetooth device.

- If you fail to connect, connection may become available after re-registration of Bluetooth devices.
- When the Bluetooth function is set to [ON], the handset is set to receive a registration request/connection request from other Bluetooth devices. Make the setting for displaying the handset's information on other Bluetooth devices in advance to allow the handset to be searched for by other Bluetooth devices.
- While in connection stand-by, even if a connection request from a Bluetooth device is received, connection may not be made depending on the signal status etc.
- For details on the operations of the other party's Bluetooth device, refer to the manuals of the Bluetooth device to be used.

When receiving registration request from Bluetooth device or connection request from unregistered Bluetooth device

1 Registration request/Connection request from Bluetooth device

2 Drag the status bar down ▶ [Pairing request] ▶ [Pair]

- When the confirmation screen about the settings on pairing appears, select [Pair].
- Entering the Bluetooth passkey may be necessary depending on the other party's Bluetooth device.
- The confirmation screen for connection may be displayed.

Disabling registration of Bluetooth device

1 In the Bluetooth screen, [↗] of the Bluetooth device to unregister ▶ [Unpair]

Disabling connection of Bluetooth device

1 In the Bluetooth screen, select the Bluetooth device to disconnect ▶ [OK]

Setting Bluetooth

- Set after setting the Bluetooth function to [ON].

1 In the Bluetooth screen, [≡]

2 Select an item

- **Rename phone:** Change the handset's name.
- **Visibility timeout:** Set how long the handset's information will be displayed on the other party's Bluetooth device.
- **aptX:** Set whether to use aptX®.
- **Handsfree setting:** Set whether to always have voices emitted from the connected Bluetooth compatible hands-free device during a voice call.
- **Disable BT Smart settings:** Enable/Disable the BT Smart settings.
- **Show received files:** Display the history of data received via Bluetooth connection.

[aptX]

- When you enable [aptX], sounds may not be emitted depending on the Bluetooth device. In this case, disable [aptX].

Sending and receiving by Bluetooth

Sending data

Example: Still picture

1 In the home screen, [⌘] ▶ [SH tool] ▶ [Recommendation] ▶ [Contents manager] ▶ [Photo]

2 Touch and hold a still picture ▶ [Share] ▶ [Bluetooth]

- Set the receiver's Bluetooth device to receive data.

3 Select a Bluetooth device to connect to

Receiving data

1 Data is sent from the sender's Bluetooth device

2 Drag the status bar down ▶ select the incoming notification ▶ [Accept]

3 Drag the status bar down ▶ select the received data

Recording time of voice recorder

Save destination	Number of entries	Recording time
Handset memory (approx. \$\$ GB)*	Up to \$\$	Up to approx. \$\$ hr

* Each recording time is up to approximately \$\$ hours.

Specific Absorption Rate (SAR) of Mobile Phone

This model SH-07E mobile phone complies with Japanese technical regulations and international guidelines regarding exposure to radio waves.

This mobile phone was designed in observance of Japanese technical regulations regarding exposure to radio waves (*1) and limits to exposure to radio waves recommended by a set of equivalent international guidelines. This set of international guidelines was set out by the International Commission on Non-Ionizing Radiation Protection (ICNIRP), which is in collaboration with the World Health Organization (WHO), and the permissible limits include a substantial safety margin designed to assure the safety of all persons, regardless of age and health condition.

The technical regulations and international guidelines set out limits for radio waves as the Specific Absorption Rate, or SAR, which is the value of absorbed energy in any 10 grams of tissue over a 6-minute period. The SAR limit for mobile phones is 2.0 W/kg. The highest SAR value for this mobile phone when tested for use at the ear is 0.652 W/kg. There may be slight differences between the SAR levels for each product, but they all satisfy the limit.

The actual SAR of this mobile phone while operating can be well below that indicated above. This is due to automatic changes to the power level of the device to ensure it only uses the minimum required to reach the network. Therefore in general, the closer you are to a base station, the lower the power output of the device. This mobile phone can be used in positions other than against your ear. This mobile phone satisfies the international guidelines when used with a carrying case or a wearable accessory approved by NTT DOCOMO, INC. (*2). In case you are not using the approved accessory, please use a product that does not contain any metals, and one that positions the mobile phone at least 1.5 cm away from your body.

The World Health Organization has stated that "a large number of studies have been performed over the last two decades to assess whether mobile phones pose a potential health risk. To date, no adverse health effects have been established as being caused by mobile phone use."

Please refer to the WHO website if you would like more detailed information.

http://www.who.int/docstore/peh-emf/publications/facts_press/fact_english.htm

Please refer to the websites listed below if you would like more detailed information regarding SAR.

Ministry of Internal Affairs and Communications Website:

<http://www.tele.soumu.go.jp/e/sys/ele/index.htm>

Association of Radio Industries and Businesses Website:

<http://www.arib-emf.org/index02.html> (in Japanese only)

NTT DOCOMO, INC. Website:

<http://www.nttdocomo.co.jp/english/product/sar/>

SHARP Corporation Website:

<http://www.sharp.co.jp/products/menu/phone/cellular/sar/index.html> (in Japanese only)

*1 Technical regulations are defined by the Ministerial Ordinance Related to Radio Law (Article 14-2 of Radio Equipment Regulations).

*2 Regarding the method of measuring SAR when using mobile phones in positions other than against the ear, international standards (IEC62209-2) were set in March of 2010. On the other hand, technical regulation is currently being deliberated on by national council (As of October, 2011).

European RF Exposure Information

Your mobile device is a radio transmitter and receiver. It is designed not to exceed the limits for exposure to radio waves recommended by international guidelines. These guidelines were developed by the independent scientific organization ICNIRP and include safety margins designed to assure the protection of all persons, regardless of age and health.

The guidelines use a unit of measurement known as the Specific Absorption Rate, or SAR. The SAR limit for mobile devices is 2 W/kg and the highest SAR value for this device when tested at the ear was 0.582 W/kg*.

As SAR is measured utilizing the devices highest transmitting power the actual SAR of this device while operating is typically below that indicated above. This is due to automatic changes to the power level of the device to ensure it only uses the minimum level required to reach the network.

* The tests are carried out in accordance with international guidelines for testing.

Declaration of Conformity

CE0168

In some countries/regions including Europe, there are restrictions on the use of 5GHz WLAN that may limit the use to indoors only. If you intend to use 5GHz WLAN on the device, check the local laws and regulations beforehand.

Herby, Sharp Telecommunications of Europe Ltd, declares that this SH-07E is in compliance with the essential requirements and other relevant provisions of Directive 1999/5/EC.

A copy of the original declaration of conformity can be found at the following Internet address:
<http://www.sharp.co.jp/k-tai/> (in Japanese only)

FCC Notice

● This device complies with part 15 of the FCC Rules.

Operation is subject to the following two conditions:

(1) This device may not cause harmful interference, and (2) this device must accept any interference received, including interference that may cause undesired operation.

● Changes or modifications not expressly approved by the manufacturer responsible for compliance could void the user's authority to operate the equipment.

Information to User

This equipment has been tested and found to comply with the limits of a Class B digital device, pursuant to Part 15 of the FCC Rules. These limits are designed to provide reasonable protection against harmful interference in a residential installation. This equipment generates, uses and can radiate radio frequency energy and, if not installed and used in accordance with the instructions, may cause harmful interference to radio communications.

However, there is no guarantee that interference will not occur in a particular installation; if this equipment does cause harmful interference to radio or television reception, which can be determined by turning the equipment off and on, the user is encouraged to try to correct the interference by one or more of the following measures:

1. Reorient/relocate the receiving antenna.
2. Increase the separation between the equipment and receiver.

3. Connect the equipment into an outlet on a circuit different from that to which the receiver is connected.
4. Consult the dealer or an experienced radio/TV technician for help.

5 GHz WLAN Operation in USA

Within the 5.15-5.25 GHz band, UNII devices are restricted to indoor operations to reduce any potential for harmful interference to co-channel Mobile Satellite Services (MSS) operations.

FCC RF Exposure Information

Your handset is a radio transmitter and receiver.

It is designed and manufactured not to exceed the emission limits for exposure to radio frequency (RF) energy set by the Federal Communications Commission of the U.S. Government.

The guidelines are based on standards that were developed by independent scientific organizations through periodic and thorough evaluation of scientific studies. The standards include a substantial safety margin designed to assure the safety of all persons, regardless of age and health.

The exposure standard for wireless handsets employs a unit of measurement known as the Specific Absorption Rate, or SAR. The SAR limit set by the FCC is 1.6 W/kg.

The tests are performed in positions and locations (e.g., at the ear and worn on the body) as required by the FCC for each model. The highest SAR value for this model handset when tested for use at the ear is 0.667 W/kg and when worn on the body, as described in this user guide, is 0.960 W/kg.

For body worn operation, this phone has been tested and meets the FCC RF exposure guidelines. Please use an accessory designated for this product or an accessory which contains no metal and which positions the handset a minimum of 1.5 cm from the body.

The use of accessories that do not satisfy these requirements may not comply with FCC RF exposure requirements, and should be avoided.

The FCC has granted an Equipment Authorization for this model handset with all reported SAR levels evaluated as in compliance with the FCC RF emission guidelines. SAR information on this model handset is on file with the FCC and can be found under the Display Grant section of <http://www.fcc.gov/oet/ea/fccid/> after searching on FCC ID APYHRO00190.

Additional information on Specific Absorption Rates (SAR) can be found on the FCC website at <http://www.fcc.gov/>.

Export Administration Regulations

The Japan Export Administration Regulations ("Foreign Exchange and Foreign Trade Act" and its related laws) will be applied to this product and its accessories under certain conditions. The Export Administration Regulations are also applied. To export or reexport the handset and its accessories, conduct all legally required procedures at your own risk and expense. For details on the procedures, contact the Ministry of Economy, Trade and Industry or the US Department of Commerce.

Intellectual Property Right



Copyrights and rights of portrait

- Data with third party copyrights such as text, images, music and software that is downloaded via Internet web pages, acquired by TV, video, etc. or shot by the handset cannot be duplicated, altered or publicly transmitted without rightful party's consent. Only duplicating, quoting, etc. for personal use are permitted under the Copyright Act.
- Even if for personal use, filming and recording may be prohibited for demonstrations, performances and exhibitions.
- Also, shooting another's image or posting another's image on Internet web pages without their consent may constitute a violation of one's right to their image.

Registered trademarks and trademarks

- "FOMA", "dメニュー", "dマーケット", "おサイフケータイ", "ToruCa", "mopera", "mopera U", "Deco-mail", "i-appli", "i-mode", "iチャンネル", "iD", "WORLD WING", "WORLD CALL", "エリアメール", "i コンシェル", "sp-mode", "eトリセツ", the "iD" logo, the "sp-mode" logo and the "Xi" logo are trademarks or registered trademarks of NTT DOCOMO, INC.
- "Catch Phone (Call waiting service)" is a registered trademark of Nippon Telegraph and Telephone Corporation.
- Microsoft®, Windows®, Windows Media®, Windows Vista® and Exchange® are trademarks or registered trademarks of Microsoft Corporation in the United States and/or other countries.
- Oracle and Java are registered trademarks of Oracle and/or its affiliates.
- Other names may be trademarks of their respective owners.
- QR code is a registered trademark of Denso Wave Inc.
- microSD Logo, microSDHC Logo and microSDXC Logo are trademarks of SD-3C, LLC.



- The handset features LCFONT, developed by Sharp Corporation, to make the LCD easier to view and read. LCフオン ト/LCFONT and  are registered trademarks of Sharp Corporation.
- OBEX™ is a trademark of Infrared Data Association®.
-  is a registered trademark of FeliCa Networks, Inc.
- Manufactured under license from Dolby Laboratories. Dolby and the double-D symbol are trademarks of Dolby Laboratories.
- PhotoScouter® is a registered trademark of Morpho, Inc.
- A O S S™ and AOSS™ are the trademarks of BUFFALO INC.
- Wi-Fi® is a registered trademark of Wi-Fi Alliance®.
- Wi-Fi Direct™, Miracast™, Wi-Fi Protected Setup™ and Wi-Fi Protected Setup logo are trademarks of Wi-Fi Alliance®. The Wi-Fi Protected Setup Mark is a mark of the Wi-Fi Alliance.
- "mixi" is a registered trademark of mixi, Inc.
- "Twitter" is a registered trademark of Twitter, Inc.
- DLNA®, the DLNA Logo and DLNA CERTIFIED™ are trademarks, service marks, or certification marks of the Digital Living Network Alliance. Sharp Corporation has acquired DLNA certification for the device.
- This product includes software developed by the OpenSSL Project for use in the OpenSSL Toolkit. (<http://www.openssl.org/>)
- This product includes cryptographic software written by Eric Young (eay@cryptsoft.com)

- Portions Copyright © 2004 Intel Corporation
This product partly uses the software of Intel Corporation.
- iWnn © OMRON SOFTWARE Co., Ltd. is used for conversion methods for Japanese language, and for phrase prediction methods for English.
iWnn © OMRON SOFTWARE Co., Ltd. 2008-2013 All Rights Reserved.
iWnn IME © OMRON SOFTWARE Co., Ltd. 2009-2013 All Rights Reserved.
- Shin Go M, the font type installed in this product, is provided by Morisawa & Company, Ltd.
* Shin Go is a registered trademark of Morisawa & Company, Ltd.
- aptX is a registered trademark of CSR plc.
- DigiOn and DiXiM are trademarks of DigiOn, Inc.
- "AQUOS", "AQUOS PHONE", "Feel UX", "Smart Familink", "MediaJet", "エコ技", "Bright Keep", "Shake OFF", "++アナザービュー", "AQUOS PHONE" logo and "エコ技" symbol are trademarks or registered trademarks of Sharp Corporation.
- All other company names and product names are trademarks or registered trademarks of the respective companies.
- Content owners use Microsoft PlayReady™ content access technology to protect their intellectual property, including copyrighted content. This device uses PlayReady technology to access PlayReady-protected content and/or WMDRM-protected content. If the device fails to properly enforce restrictions on content usage, content owners may require Microsoft to revoke the device's ability to consume PlayReady-protected content. Revocation should not affect unprotected content or content protected by other content access technologies. Content owners may require you to upgrade PlayReady to access their content. If you decline an upgrade, you will not be able to access content that requires the upgrade.
- The abbreviations of operating systems (Japanese versions) below are used in this manual.
 - Windows 8 stands for Microsoft® Windows® 8, Microsoft® Windows® 8 Pro and Microsoft® Windows® 8 Enterprise.
 - Windows 7 stands for Microsoft® Windows® 7 (Starter, Home Basic, Home Premium, Professional, Enterprise and Ultimate).
 - Windows Vista stands for Windows Vista® (Home Basic, Home Premium, Business, Enterprise and Ultimate).
 - Windows XP indicates the Microsoft® Windows® XP Professional operating system or Microsoft® Windows® XP Home Edition operating system.

Others

- FeliCa is a contactless IC card technology developed by Sony Corporation. FeliCa is a registered trademark of Sony Corporation.
- Under the MPEG-4 Visual Patent Portfolio License, customers have licensed permission for the following use of this product to engage in non-profit personal use. Other uses are not permitted.
 - Encoding MPEG-4 standard video (henceforth referred to as MPEG-4 video).
 - Decoding an MPEG-4 video that a customer not engaged in personal commercial activities has encoded.
 - Decoding an MPEG-4 video obtained from a licensed provider. For details on other intended uses, contact MPEG LA, LLC.
- This product is licensed under the MPEG-4 Systems Patent Portfolio License for encoding in compliance with the MPEG-4 Systems Standard. An additional license and payment of royalties are necessary in the following cases.
 - Data stored or replicated in physical media which is paid for on a title by title basis.
 - Data which is paid for on a title by title basis and is transmitted to an end user for permanent storage and/or use. Such additional license may be obtained from MPEG LA, LLC. Contact MPEG LA, LLC for additional details.
- This product is licensed under the AVC patent portfolio license for the personal and noncommercial use of a consumer to (i) encode video in compliance with the AVC standard (henceforth referred to as AVC video) and/or (ii) decode AVC video that was encoded by a consumer engaged in a personal and noncommercial activity and/or was obtained from a video provider licensed to provide AVC video. No license is granted or shall be implied for any other use. Additional information may be obtained from MPEG LA, L.L.C.
See <http://www.mpegla.com>
- This product is licensed under the VC-1 Patent Portfolio License for the personal and noncommercial use of a consumer to (i) encode video in compliance with the VC-1 standard (henceforth referred to as VC-1 video) and/or (ii) decode VC-1 video that was encoded by a consumer engaged in a personal and noncommercial activity and/or was obtained from a video provider licensed to provide VC-1 video. No license is granted or shall be implied for any other use. Additional information may be obtained from MPEG LA, L.L.C.
See <http://www.mpegla.com>
- The Bluetooth word mark and logos are owned by the Bluetooth SIG, INC. and any use of such marks by NTT DOCOMO, INC. is under license. Other trademarks and trade names are those of their respective owners.
- Google, Google logo, Android, Android logo, Google Play, Google Play logo, Google+, Google+ logo, ++Google メッセージャー, ++Google メッセージャー logo, ++Google 設定, ++Google 設定 logo, Gmail, Gmail logo, Calendar logo, Google Maps™, Google Maps logo, Google Talk, Google Talk logo, Google Chrome™, Google Chrome logo, Google Voice Search™ logo, Picasa™, Picasa logo, YouTube and YouTube logo are trademarks of Google Inc.

Open source software

- This product includes software based on GNU General Public License (GPL), GNU Lesser General Public License (LGPL) and other licenses.
For details on licenses of related software, in the home screen, [⌘] ▶ [Settings] ▶ [Device info] ▶ [Legal information] ▶ [Open source licenses].
- Source codes of software based on GPL, LGPL and Mozilla Public License (MPL) can be referred to on the following website for free. For details, refer to the following website.
[https://sh-dev.sharp.co.jp/android/modules/oss/\(in Japanese only\)](https://sh-dev.sharp.co.jp/android/modules/oss/(in%20Japanese%20only))

Unlocking SIM lock

- The handset can unlock the SIM lock. Unlock the SIM lock to use non-DOCOMO SIM cards.
- SIM lock can be unlocked at a docomo Shop.
- Commission is incurred separately for unlocking SIM lock.
- When using non-DOCOMO SIM card, it cannot be used in LTE. Also, some services and functions are unavailable. DOCOMO shall not guarantee any operation of the handset.
- For details on unlocking SIM lock, refer to the DOCOMO website.

Check/Change the subscription, apply for various services, and request various information materials online.

From sp-mode dmenu ▶ お客様サポート (Support) ▶ 各種お申込・お手続き (Various Applications/Procedures) (free of packet communication charges) (in Japanese only)

From a PC My docomo (<http://www.mydocomo.com/>) ▶ 各種お申込・お手続き (Various Applications/Procedures) (in Japanese only)

- ※ Use "network security code" to access from sp-mode.
- ※ Some services may be charged when you access the website from sp-mode.
- ※ Use "docomo ID/Password" to access from a PC.
- ※ If you do not have or you have forgotten your "network security code" or "docomo ID/Password", contact the number listed in "General Inquiries" on the last page.
- ※ The websites may not be available depending upon the content of your subscription.
- ※ You may not be able to access some website services due to system maintenance etc.

Using mobile phone with your manners!

Please be considerate of those around you when using the handset.

Turn off your handset in the following places

■ When in an area where use is prohibited

When you are on an airplane or in a hospital, follow the instructions given by the respective airlines or medical facilities. Turn off the handset in areas where the use of mobile phones is prohibited.

Set the Public mode in the following places

■ While driving

Using a mobile phone in hand while driving is regarded as a punishable act. However, some cases such as when rescuing sick and injured people or maintaining public safety are exempted.

■ When in public places such as theaters, movie theaters or museums

Using the handset in public places where you should be quiet results in disturbing others.

Be aware of the place to use a mobile phone and the volume of your voice and ringtone

■ Be aware of the volume of your voice when using the handset in quiet places such as restaurant and hotel lobby.

■ Use in places where you do not block a passage in the town.

Be considerate of the privacy of the individuals around you

⚠ Please be considerate of the privacy of individuals around you when taking and sending photos using camera-equipped mobile phones.

These functions ensure the manner in public

The handset has convenient functions such as setting not to answer a call and setting to mute sound of the handset.

- **Manner mode** (☎ P. 60)
Mutes sound of the handset.
※ However, the manner mode cannot mute camera shutter sound.
- **Public Mode (Phone OFF)** (☎ P. 34)
When a call is received, a message stating that you are in a place that does not allow the use of mobile phone is played and the call is automatically disconnected.
- **Phone vibrate** (☎ P. 60)
Notifies you of incoming call with vibration.
- **Answer Memo** (☎ P. 33)
Records callers' messages when you cannot answer the call.
※ Additionally, optional services such as Voice Mail Service (☎ P. 34 and Call Forwarding Service (☎ P. 34) are available.



モバイルリサイクルネットワーク
株式会社ドコモリサイクル

We collect your unnecessary mobile phones and other devices irrespective of carrier. Bring them to a docomo Shop near you.

※ Intended devices: Mobile phone, PHS, battery pack, charger and desktop holder (irrespective of carrier)