

General Inquiries <docomo Information Center>

(Business hours: 9:00 a.m. to 8:00 p.m.)

 **0120-005-250 (toll free)**

※ Service available in: English, Portuguese, Chinese, Spanish.

※ Unavailable from part of IP phones.

(Business hours: 9:00 a.m. to 8:00 p.m. (open all year round))

■ **From DOCOMO mobile phones (In Japanese only)**

 **(No prefix) 151 (toll free)**

※ Unavailable from land-line phones, etc.

■ **From land-line phones (In Japanese only)**

 **0120-800-000 (toll free)**

※ Unavailable from part of IP phones.

● Please confirm the phone number before you dial.

● For Applications or Repairs and After-Sales Service, please contact the above-mentioned information center or the docomo Shop etc. near you on the NTT DOCOMO website.

NTT DOCOMO website <https://www.nttdocomo.co.jp/english/>

For loss, theft, malfunction, and inquiries while overseas (24-hour reception)

■ **From DOCOMO mobile phones**

International call access code for the country you stay -81-3-6832-6600* (toll free)

* You are charged a call fee to Japan when calling from a land-line phone, etc.

※ If you use SH-05G, you should dial the number +81-3-6832-6600 (to enter "+", touch and hold "0").

■ **From land-line phones <Universal number>**

Universal number international prefix -8000120-0151*

* You might be charged a domestic call fee according to the call rate for the country you stay.

※ For international call access codes for major countries and universal number international prefix, refer to DOCOMO website.

● **If you lose your tablet or have it stolen, immediately take the steps necessary for suspending the use of the tablet.**

● **If the tablet you purchased is damaged, bring your tablet to a repair counter specified by DOCOMO after returning to Japan.**



Don't forget your mobile phone... or your manners!

When using your mobile phone in a public place, don't forget to show common courtesy and consideration for others around you.

Repairs

(Business hours: 24 hours (open all year round))

■ **From DOCOMO mobile phones**

(In Japanese only)

 **(No prefix) 113 (toll free)**

※ Unavailable from land-line phones, etc.

■ **From land-line phones (In Japanese only)**

 **0120-800-000 (toll free)**

※ Unavailable from part of IP phones.

NTT
docomo

AQUOS *PAD* SH-05G

INSTRUCTION MANUAL '15.●

Sales: NTT DOCOMO, INC.
Manufacturer: SHARP Corporation

'15.● (1st Edition)
15● HI***①



Li-Ion00

Introduction

Thank you for purchasing “SH-05G”.

Be sure to read this manual before and during use to ensure proper operation.

Checking operation method

Quick Start Guide (Basic package) (in Japanese only)

This guide describes operations of basic functions.

User's Manual (App of the tablet) (in Japanese only)

This manual describes detailed guidance and operations of functions.

In the home screen, [] ▶ [Instruction Manual]

User's Manual (in PDF format)

This manual describes detailed guidance and operations of functions.

Download from the DOCOMO website

<https://www.nttdocomo.co.jp/english/support/trouble/manual/download/index.html>

※ The URL and contents are subject to change without prior notice.

- The screens and illustrations in this manual are shown as examples. The actual screens and illustrations may differ.
- The explanations in this manual are based on the case when the home app is docomo LIVE UX. If you change the home app, operation procedures etc. may be different from the explanations of this manual.
- Note that “SH-05G” is referred to as “tablet” in this manual.
- This manual refers to microSD Card, microSDHC Card or microSDXC Card as “microSD Card” or “microSD”.
- Reproduction of this manual in part or in whole without prior permission is prohibited.
- The contents of this manual are subject to change without prior notice.

Basic package

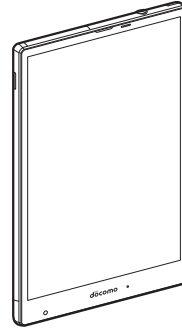

SH-05G
(includes warranty)

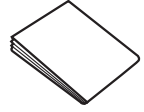

Quick Start Guide
(in Japanese only)

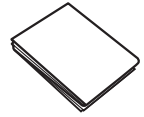



Notes on usage
(in Japanese only)







- For optional parts (sold separately) compatible with the tablet, refer to the DOCOMO website.
<https://www.nttdocomo.co.jp/product/option/> (in Japanese only)

Precautions (ALWAYS FOLLOW THESE DIRECTIONS)

- Before use, read these “Precautions” carefully and use your tablet properly.
Keep this manual in a safe place for future reference.
 - These precautions contain information intended to prevent bodily injury to the user and to surrounding people, as well as damage to property, and must be observed at all times.
- The following symbols indicate the different degrees of injury or damage that may occur if information provided is not observed and the tablet is used improperly.

 Danger	This symbol indicates that “death or serious bodily injury may directly and immediately result from improper use”.
 Warning	This symbol indicates that “death or serious bodily injury may result from improper use”.
 Caution	This symbol indicates that “minor injury and/or property damage may result from improper use”.

The following symbols indicate specific directions.







 Don't	Indicates a prohibited action.	 No wet hands	Indicates not to handle the device with wet hands.
 No disassembly	Indicates not to disassemble the device.	 Instruction	Indicates that instructions specified are compulsory (must be followed).
 No liquids	Indicates not to use the device near water or get it wet.	 Unplug	Indicates that the power cord must be unplugged from the outlet.

“Precautions” is explained in the following six sections.





- Handling the tablet, adapters and docomo nano UIM card (general) P. 4
- Handling the tablet P. 5
- Handling adapters P. 6
- Handling docomo nano UIM card P. 7
- Handling near electronic medical equipment P. 7
- Material list P. 7

Handling the tablet, adapters and docomo nano UIM card (general)

Danger

-  **Don't** Do not use, store or leave the equipment in locations subject to high temperatures (near a fire or heating unit, in a kotatsu, under direct sunlight, inside a vehicle on a hot day, etc.).
May cause fires, burns or bodily injury.
-  **Don't** Do not place the equipment inside cooking appliances such as microwave ovens or pressure cookers.
May cause fires, burns, bodily injury or electric shock.
-  **No disassembly** Do not attempt to disassemble or modify the equipment.
May cause fires, burns, bodily injury or electric shock.
-  **No liquids** Do not get the equipment wet with water, drinking water, pet urine, sweat, etc.
May cause fires, burns, bodily injury or electric shock. Refer to the following for details on waterproofness. P. 10 “Waterproof”
-  **No liquids** Do not allow liquids (water, drinking water, pet urine, sweat, etc.) to get inside the charger terminal, external connector terminal or earphone/microphone terminal.
May cause fires, burns, bodily injury or electric shock. Refer to the following for details on waterproofness. P. 10 “Waterproof”
-  **Instruction** Use only optional parts specified by NTT DOCOMO for use with the tablet.
May cause fires, burns, bodily injury or electric shock.

Warning

-  **Don't** Do not subject the equipment to strong force or impacts or throw it.
May cause fires, burns, bodily injury or electric shock.
-  **Don't** Do not allow conductive materials (such as metal objects and pencil lead) to come into contact with the charger terminal, external connector terminal or earphone/microphone terminal. In addition, do not insert such objects.
May cause fires, burns, bodily injury or electric shock.
-  **Don't** Do not cover or wrap the equipment with bedding etc. when using or charging.
May cause fires or burns.
-  **Instruction** Be sure to turn off the tablet and not to charge the battery in locations such as gas stations where flammable gas may be generated.
May cause a gas explosion or fire.
To use Osaifu-Keitai in locations such as gas stations, be sure to turn off the power in advance (If NFC/Osaifu-Keitai lock is set, disable the lock before turning off the power).
-  **Instruction** If you notice anything unusual, such as an unusual odor, overheating, discoloration or deformation during use, charging or storage, immediately follow the instructions below.
 - Unplug the power plug from the outlet or cigarette lighter socket.
 - Turn off the tablet.
 May cause fires, burns, bodily injury or electric shock.

Caution

 **Do not leave the equipment on unstable surfaces, such as on a wobbly table or sloped surface.**
May fall and cause injury.

 **Do not store the equipment in locations that are subject to humidity, dust or high temperatures.**
May cause fires, burns or electric shock.

 **If being used by a child, have a guardian teach him/her the proper handling procedures. In addition, check that the child is using the equipment as directed.**
May result in bodily injury etc.

 **Keep the equipment out of the reach of young children.**
A young child may swallow the equipment, or suffer bodily injury or electric shock.

 **Be very careful when using the tablet connected to an adapter continuously for a long time.**
The tablet or adapter may become warm if you use an app or video call, watch a video or TV, etc. for a long time while charging.
Directly touching a warmed part for a long time may cause redness, itching, rashes, etc. on your skin, or result in low-temperature burns depending on your constitution or health condition.

Handling the tablet

The following is the type of the internal battery built into the tablet.

Label	Battery type
Li-ion00	Lithium-ion

Danger

 **Do not throw the tablet into a fire or heat it.**
The internal battery may catch fire, explode, overheat or leak.

 **Do not apply excessive force on the tablet such as by puncturing it, hitting it with a hammer or stepping on it.**
The internal battery may catch fire, explode, overheat or leak.

 **If the battery fluid etc. comes into contact with your eyes, do not rub your eyes but immediately rinse your eyes with clean water. Then seek prompt medical treatment.**
May result in loss of eyesight.

Warning

 **Do not point the illuminated light directly at someone's eyes. Especially when you shoot still pictures or videos of young children, keep 1 m or more distance from them.**
Do not use Mobile light near people's faces. Eyesight may be temporarily affected leading to accidents.

 **Do not allow water or other liquids, metal, flammable material or other foreign objects to enter the docomo nano UIM card slot or microSD Card slot on the tablet.**
May cause fires, burns, bodily injury or electric shock.

 **Do not shine the mobile light at anyone driving a car or other vehicles.**
May prevent a driver from driving safely and cause a traffic accident.

 **Turn off the tablet or set it to Airplane mode before going aboard an airplane.**
Since using the tablet on airplanes is restricted, follow the instructions given by the respective airlines.
May interfere with the operation of electronic devices installed on the airplane.
If you commit a prohibited act while using the tablet on an airplane, you may be punished by law.

 **Follow the instructions given by the respective medical facility regarding the use of the tablet in a hospital.**
Turn off the tablet in areas where the use of mobile phones is prohibited.
May interfere with the operation of electronic devices and electronic medical equipment.

 **Keep the tablet away from the ears during a call in which hands-free is set or while the ringtone is ringing.**
When you attach the earphone/microphone etc. to the tablet to play games, music, etc., do not make the volume too loud.
Excessively high volume may damage your hearing.
Also, it may prevent you from hearing ambient sounds and cause an accident.

 **If you have a weak heart, take extra precautions when setting functions such as the vibrator and ringtone volume for incoming calls.**
May have harmful effects on your heart.

 **If you are using electronic medical equipment etc., contact the respective manufacturer or dealer to check whether the operation of the equipment is affected by signals.**
May interfere with the operation of electronic medical equipment etc.

 **Turn off the tablet near high-precision electronic devices or devices that use weak electronic signals.**
May interfere with the operation of electronic devices.
※ Take particular care with the following devices
Hearing aids, implanted cardiac pacemakers, implanted cardioverter-defibrillators or other electronic medical equipment. Fire alarms, automatic doors, and other equipment controlled by electronic signals. If you use an implanted cardiac pacemaker, implanted cardioverter-defibrillator or other electronic medical equipment, contact the respective manufacturer or dealer to check whether the operation of the equipment is affected by signals.

 **If the display part or camera lens is damaged, be careful of broken glass and the exposed inside of the tablet.**
Tape is pasted on the back of the display while the surface of the display is covered by a protective film and the surface of the camera lens is covered by a plastic panel so as to minimize the possibility of glass scattering. However, touching the broken or exposed parts may cause bodily injury.



Instruction

If the internal battery leaks or emits an unusual odor, immediately stop using the tablet and move it away from any naked flames or fire.

The battery fluid is flammable and could ignite, causing a fire or explosion.

Caution



Don't

Do not swing the tablet by its antenna etc.

May hit you or others around you, resulting in an accident such as bodily injury.



Don't

Do not use a damaged tablet.

May cause fires, burns, bodily injury or electric shock.



Don't

For using a motion sensor and geomagnetic sensor, check the safety around, hold the tablet and do not swing it more than necessary.

May cause an accident such as bodily injury.



Don't

If the display is broken and the liquid crystal then leaks, do not get the liquid on your skin (face, hands, etc.).

May result in loss of eyesight or harm to your skin.

If the liquid crystal comes into contact with your eyes or mouth, immediately rinse the contacted area with clean water and seek medical treatment.

If the liquid crystal comes into contact with your skin or clothes, immediately wipe the liquid crystal off with alcohol etc., and rinse the contacted area with soap etc.



Don't

The surface of the display is covered with a protective film for ensuring the security (shatterproof property of reinforced glass panel) against any damages caused by the tablet being dropped or receiving a strong impact etc. Do not remove the film forcibly or damage it.

Using the tablet with the film removed may cause bodily injury if the display gets damaged.



Don't

Do not dispose of the tablet in ordinary garbage.

May cause fires or damage to the environment. Take the unnecessary tablet to a sales outlet such as a docomo Shop or follow the instructions by a local institution that handles used tablets.



Instruction

If you use the tablet in a vehicle, contact the vehicle manufacturer or dealer to check whether the operation of the vehicle is affected by signals.

May interfere with the operation of electronic equipment in some vehicle models. In this case, stop using the tablet.



Instruction

Use of the tablet may cause itching, rashes, eczema, etc. depending on your constitution or health condition. If this occurs, immediately stop using the tablet and seek medical treatment.

For details on materials of each part P. 7 "Material list"



Instruction

Look at the display in a well-lit place, keeping a certain distance from the screen.

Otherwise, eyesight may be weakened.



Instruction

If the battery fluid etc. leaks, do not get the liquid on your skin (face, hands, etc.).

May result in loss of eyesight or harm to your skin.

If the liquid etc. comes into contact with your eyes, mouth, skin or clothes, immediately rinse the contacted area with clean water.

If the liquid etc. comes into contact with your eyes or mouth, seek medical treatment immediately after rinsing the contacted area.

Handling adapters

Warning



Don't

Do not use if the cord of the adapter is damaged.

May cause fires, burns or electric shock.



Don't

Never use the AC adapter in humid locations such as a bathroom.

May cause fires, burns or electric shock.



Don't

The DC adapter should only be used in negative grounded vehicles. Never use it in positive grounded vehicles.

May cause fires, burns or electric shock.



Don't

Do not touch adapters if you hear thunder.

May cause electric shock.



Don't

Do not short-circuit the charger terminal when connected to an outlet or cigarette lighter socket. Also, do not allow any part of your body (hands, fingers, etc.) to come into contact with the charger terminal.

May cause fires, burns or electric shock.



Don't

Do not place heavy objects on the cord of the adapter.

May cause fires, burns or electric shock.



Don't

When plugging/unplugging an AC adapter into/from the outlet, do not allow metallic straps or other metallic objects to come into contact with the prongs of the plug.

May cause fires, burns or electric shock.



Don't

Do not apply excessive force on an adapter by moving it up/down or to the left/right with the adapter connected to the tablet.

May cause fires, burns, bodily injury or electric shock.



Don't

Never try to connect the microUSB plug when the tablet or AC adapter is wet.

Inserting the microUSB plug while the equipment is wet may cause short circuit when you charge the battery and lead to abnormal overheat, malfunction, fires or burns due to water, foreign objects, etc. adhering to the tablet or microUSB plug though the tablet provides waterproof performance.



No wet hands

Do not handle the cord or charger terminal of the adapters or outlet with wet hands.

May cause fires, burns or electric shock.



Instruction

Always use the specified power supply and voltage. When using overseas, use the AC adapter that is available overseas.

Using the incorrect voltage may cause fires, burns or electric shock.

AC adapter: 100V AC

DC adapter: 12/24V DC (for negative grounded vehicles only)

AC adapter available overseas: 100 to 240V AC (Connect only with a household AC outlet)



Instruction

If the fuse in the DC adapter blows, always replace it with a specified fuse.

May cause fires, burns or electric shock. Refer to the respective manuals for information on specified fuses.



Instruction

Wipe off any dust on the power plug.

May cause fires, burns or electric shock.



Fully plug the AC adapter into the outlet.
May cause fires, burns or electric shock.

Instruction



Always grasp the adapters when unplugging the power plug from the outlet or cigarette lighter socket. Do not forcibly pull by the cord of the adapter.

Instruction

May cause fires, burns or electric shock.



When plugging/unplugging an adapter into/from the tablet, plug/unplug the adapter horizontally and straightly, not applying excessive force on it.

Instruction

May cause fires, burns, bodily injury or electric shock.



Unplug the power plug from the outlet or cigarette lighter socket when not using for a long time.

Unplug

May cause fires, burns or electric shock.



Should water or other liquids enter the equipment, remove the power plug from the outlet or cigarette lighter socket immediately.

Unplug

May cause fires, burns or electric shock.



Always unplug the power plug from the outlet or cigarette lighter socket before cleaning the equipment.

Unplug

May cause fires, burns or electric shock.

Caution



Do not touch the adapter for a long time when connected to an outlet or cigarette lighter socket.

Don't

May cause burns etc.

Handling docomo nano UIM card

Caution



Be careful with the cutting surface when handling the docomo nano UIM card.

Instruction

May cause bodily injury.

Handling near electronic medical equipment

Warning



If you have electronic medical equipment such as an implanted cardiac pacemaker or an implanted cardioverter-defibrillator, always carry or use your tablet at least 15 cm away from your implant.

Instruction

Electromagnetic signals may have harmful effects on the operation of the electronic medical equipment.



Patients receiving medical treatment away from a medical facility (e.g. home treatment) who are using electronic medical equipment other than implanted cardiac pacemakers or implanted cardioverter-defibrillators should consult the respective manufacturers etc. for information regarding the effects of signals on the equipment.

Instruction

Electromagnetic signals may have harmful effects on the operation of the electronic medical equipment.



If there is any chance that the distance between the tablet and a person closest to you may get shorter than 15 cm such as when you cannot freely move around, set the tablet not to emit radio wave in advance (by setting Airplane mode, turning the power off, etc.).

Instruction

Somebody nearby may be equipped with electronic medical equipment such as an implanted cardiac pacemaker or an implanted cardioverter-defibrillator. Electromagnetic signals may have harmful effects on the operation of the electronic medical equipment.



Follow the instructions given by the respective medical facilities regarding the use of the tablet on their premises.

Instruction

Material list

Tablet

Part	Material/Surface treatment
Display side	Reinforced glass/Shatterproof sheet of surface
Surrounding area of display side	PA resin/UV coating for surface
Upper surface	PC resin/Deposition
Bottom surface	PC resin/Deposition
Sides	PC resin/Deposition
Back	PET + PC + PET resin/Hard coating for surface
Surrounding area of back	PA resin/UV coating for surface
docomo nano UIM card slot	SUS/Ni plating
microSD Card slot	SUS/Ni plating
docomo nano UIM card/microSD Card slot cover	PC resin/Deposition
Gasket of docomo nano UIM card/microSD Card slot cover	Silicon rubber
Sticker indicating position for inserting docomo nano UIM card/microSD Card	PET resin
Tray for inserting docomo nano UIM card	POM resin
IMEI plate	PC resin
Surrounding area of earphone/microphone terminal	Nylon resin
Power key	ABS resin/Deposition
Side key	ABS resin/Deposition
Camera panel	PMMA + PC resin/Hard coating for surface
Decoration of camera	Aluminum/Anodizing
Metal section of Mobacas/TV antenna	SUS/NiTi
Mobacas/TV antenna	PA resin/Deposition
External connector terminal	SUS/Ni plating, Copper alloy/Gold plating

Handling precautions

General notes

- **SH-05G is waterproof, however, do not allow water to get inside the tablet and do not allow optional parts to get wet.**
The adapter and docomo nano UIM card are not waterproof. Do not use in humid or steamy areas such as bathrooms and avoid exposing to rain and other forms of moisture. If they are carried close to the skin, perspiration may cause internal components to corrode and result in malfunction. Note that if a problem is found to be due to moisture, the tablet and parts are not covered by warranty and in some cases may be irreparable. Even when repairs are possible, repair charges will be incurred, since the damage is not covered by warranty.
- **Clean only with a soft and dry cloth (such as the type used for eyeglasses).**
 - Forceful rubbing of the display with a dry cloth etc. may scratch its surface.
 - Water drops, dirt, etc. left on the display may cause stains to form on its surface.
 - Never use chemicals such as alcohol, thinners, benzene or detergents, as these agents may erase the printing or cause discoloration.
- **Occasionally clean terminals with a dry cotton swab etc.**
Dirty terminals may result in poor connections and loss of power or insufficient battery charge. Keep the terminals clean with a dry cotton swab etc.
Be careful with the terminals while cleaning them.
- **Do not place the equipment near an air conditioning vent.**
Condensation formed due to rapid changes in temperature may cause internal corrosion and lead to a malfunction.
- **Do not apply excessive force on the tablet etc. when using it.**
Carrying the equipment in a tightly packed bag or sitting on it put in your pocket may cause damage to the display, internal components, etc. or result in a malfunction.
Keeping an external connector device plugged into the external connector terminal or earphone/microphone terminal may cause damage or a malfunction.
- **Do not rub or scratch the display with metal etc.**
May scratch it and cause a malfunction or damage.
- **Read the respective user's guides supplied with supported optional parts carefully.**

Notes about the tablet

- **Do not forcefully press the surface of the touch panel or operate with a pointed object such as a fingernail, ballpoint pen or pin.**
May damage the touch panel.
- **Avoid using the tablet in extremely high or low temperatures.**
Use the tablet within the range of a temperature between 5°C and 35°C and a humidity between 45% and 85%.
- **Using the tablet close to land-line phones, TVs, radios, etc. may have harmful effects on the operation of such equipment. Move as far away as possible from such items before use.**
- **Keep a separate memo noting information stored on the tablet.**
DOCOMO shall not be liable for any loss of content.
- **Do not drop or otherwise subject the tablet to severe impact.**
May cause a malfunction or damage.
- **When connecting an external connector device to the external connector terminal or earphone/microphone terminal, do not put it in obliquely and do not pull it while it is plugged in.**
May cause a malfunction or damage.

- **The tablet becomes warm during use or charging but this is not a malfunction.**
- **Do not leave the camera in direct sunlight.**
May cause discoloration or burn-in of pixels.
- **Use the tablet with the docomo nano UIM card/microSD Card slot cover closed.**
Dust, water, etc. may get inside and cause a malfunction.
- **While using a microSD Card, do not remove the card or turn off the tablet.**
May cause data loss or a malfunction.
- **Never place a magnetic card near the tablet.**
The stored magnetic data in cash cards, credit cards, telephone cards, floppy disks, etc. may be erased.
- **Never place magnetized items near the tablet.**
Putting highly magnetized items closer may cause an error.
- **The internal battery is a consumable product.**
Though the battery life varies with use, change the battery if the battery life is extremely short even after being fully charged. For details on replacing the internal battery, contact the number listed in "Repairs" (in Japanese only) on the last page or a repair counter that DOCOMO specifies.
- **Charge battery in areas where ambient temperature is between 5°C and 35°C.**
- **The battery life depends on the usage and deterioration of the battery.**
- **Avoid the following situations when the tablet is stored.**
 - Storage with the internal battery fully charged (immediately after charging is completed)
 - Storage with no battery level (cannot turn the tablet on)
May lower the performance or shorten the usable life of the internal battery.
Approximately 40% is recommended as the proper battery level for storage.
- **The surface of the tablet uses the aluminum material. Note that dent and abrasion are easily remained as aluminum is a soft material.**

Notes about adapters

- **Charge the battery in areas where the ambient temperature is between 5°C and 35°C.**
- **Do not charge the internal battery in the following locations.**
 - Areas with high humidity or dust, or in areas exposed to frequent vibrations
 - Close to land-line phones, TVs, radios, etc.
- **Adapters may become warm during charging but this is not a malfunction.**
- **Do not use the DC adapter to charge the battery when the car engine is not running.**
May cause the car battery to run down.
- **When using an outlet with a feature to prevent the plug from being removed accidentally, follow the instructions in the outlet user's guide.**
- **Do not subject to strong impacts. Also, do not deform the charger terminals.**
May cause a malfunction.

Notes about docomo nano UIM card

- **Do not apply unnecessary force when inserting/removing the docomo nano UIM card.**
- **Customer is responsible for malfunctions arising from inserting docomo nano UIM card into a different IC card reader/writer etc.**
- **Always keep IC area clean.**
- **Clean only with a soft and dry cloth (such as the type used for eyeglasses).**
- **Keep a separate memo and note information stored on the docomo nano UIM card.**
DOCOMO shall not be liable for any loss of content.

- To protect the environment, please take any unneeded docomo nano UIM cards to a sales outlet such as a docomo Shop.
- Do not damage, touch haphazardly or short-circuit the IC.
May cause data loss or a malfunction.
- Do not drop or otherwise subject the docomo nano UIM card to severe impact.
May cause a malfunction.
- Never bend the docomo nano UIM card or place heavy objects on it.
May cause a malfunction.
- Do not insert the docomo nano UIM card to the tablet with a label, sticker, etc. attached on the card.
May cause a malfunction.

Notes on using Bluetooth function

- The tablet supports the security function that meets the Bluetooth specification for security during communication using Bluetooth functions. However, the security may not be sufficient depending on the configuration etc. Take care of the security while making communication using Bluetooth function.
- Even if any leak of data or information occurs while making communication using Bluetooth function, DOCOMO shall not be liable for any loss of content.
- Radio frequencies
In the home screen, [Settings] ▶ [About tablet] ▶ [Authentication] to confirm the radio frequencies the Bluetooth function of the tablet uses. The followings are the descriptions:



⑥

- ① 2.4: This radio equipment uses the 2,400 MHz band.
- ② FH: The modulation system is the FH-SS system.
- ③ 1: The estimated coverage distance is 10 m or less.
- ④ XX: Another modulation system is used.
- ⑤ 4: The estimated coverage distance is 40 m or less.
- ⑥ ■■■■■: All radio frequencies between 2,400 MHz and 2,483.5 MHz are used and the frequencies for mobile object identifiers cannot be avoided.

- Cautions on using Bluetooth devices
Bluetooth operates at radio frequencies assigned to the in-house radio stations for a mobile object identifier that have to be licensed and are used in production lines of a factory, specific unlicensed low power radio stations, and amateur radio stations (hereafter, referred to as “another radio station”) in addition to industrial, scientific and medical devices or home electric appliances such as microwave ovens.

 1. Before using the tablet, make sure that “another radio station” is not operating nearby.
 2. If radio interference between the tablet and “another radio station” occurs, avoid interference by moving immediately to another place or “turning off the power”.
 3. Contact the number listed in “General Inquiries” on the last page for further details.

Notes about wireless LAN (WLAN)

- Wireless LAN (WLAN) uses radio waves to communicate information. Therefore, it has an advantage of freely connecting to the LAN within the service area. On the other hand, if security setting is not set, it is possible for a malicious third party to intercept the communication contents or hack. It is recommended to set security setting at your own risk and judgement.
- Wireless LAN
Do not use wireless LAN near magnetic devices such as electric appliances or AV/OA devices or in radio waves.
 - Magnetism or radio waves may increase noises or disable communications (especially when using a microwave oven).
 - When used near TV, radio, etc., reception interference may occur or channels on the TV screen may be disturbed.
 - If there are multiple wireless LAN access points nearby and the same channel is used, search may not work correctly.
- Radio frequencies
In the home screen, [Settings] ▶ [About tablet] ▶ [Authentication] to confirm the radio frequencies the WLAN-installed devices use. The followings are the descriptions:

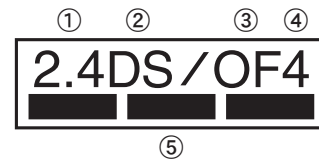

- ① 2.4: This radio equipment uses the 2,400 MHz band.
- ② DS: The modulation system is the DS-SS system.
- ③ OF: The modulation system is the OFDM system.
- ④ 4: The estimated coverage distance is 40 m or less.
- ⑤ ■■■■■: All radio frequencies between 2,400 MHz and 2,483.5 MHz are used and the frequencies for mobile object identifiers can be avoided.

Available channels for the tablet's wireless LAN are between 1 and 13. Note that other channel access points cannot be connected. Available channels may vary depending on the country. For use in an aircraft, contact the airline beforehand.

- Cautions on using 2.4 GHz devices
WLAN-installed devices operate at radio frequencies assigned to the in-house radio stations for a mobile object identifier (radio stations requiring a license) used in production lines of a factory, specific low power radio stations (radio stations requiring no license), and amateur radio stations (radio stations requiring a license) in addition to industrial, scientific and medical devices or home electric appliances such as microwave ovens.

 1. Before using this device, make sure that the in-house radio stations for a mobile object identifier, specific low power radio stations and amateur radio stations are not operating nearby.
 2. If the device causes harmful radio interference to the in-house radio stations for a mobile object identifier, immediately change the radio frequency or stop use, and contact the number listed in “General Inquiries” on the last page for crosstalk avoidance, etc. (e.g. partition setup).
 3. If the device causes radio interference to specific low power radio stations for a mobile object identifier or amateur radio stations, contact the number listed in “General Inquiries” on the last page for further details.

- Cautions on using 5 GHz devices
In the 5 GHz frequency band, three bands of 5.2 GHz/5.3 GHz/5.6 GHz band (W52/W53/W56) are available.
 - W52 (5.2 GHz band/36, 40, 44, 48 ch)
 - W53 (5.3 GHz band/52, 56, 60, 64 ch)
 - W56 (5.6 GHz band/100, 104, 108, 112, 116, 120, 124, 128, 132, 136, 140 ch)
Using 5.2 GHz/5.3 GHz band wireless LAN (W52/W53) outdoors is prohibited by the Radio Law.

FeliCa and NFC reader/writer

- The FeliCa, NFC reader/writer and P2P function of the tablet use weak radio waves whose handling does not require a license of radio station.
- The frequency in use is the 13.56 MHz band. When another reader/writer or P2P function is being used nearby, keep enough distance from it. Make sure that there is no radio station using the same frequency band in the nearby area.
- For use in an aircraft, contact the airline beforehand. Use of the function may be restricted in some countries. Check conditions such as regulations of the country/region to use the function.

Caution

- **Never use the tablet that is modified. Using a modified device violates the Radio Law and/or the Telecommunications Business Law.**

The tablet follows the regulations regarding the certification of conformity with technical regulations for specific radio stations etc. based on the Radio Law and authentication of conformity with technical regulations for devices etc. based on the Telecommunications Business Law, and the "Technical Conformity Mark  can be displayed on the electronic nameplate of the tablet as a proof. You can see it by operating as follows.

In the home screen,  [Settings] ▶ [About tablet] ▶ [Authentication]

If the screws of the tablet are removed and a modification is given to the inside, the certification of conformity with technical regulations etc. will become invalid. Never use the tablet without the valid certification etc. Doing so violates the Radio Law and/or the Telecommunications Business Law.

- **Be careful when using the tablet while driving a motor vehicle.**

Using the tablet in hand while driving is regarded as a punishable act. However, the punishment has no application in some cases such as when rescuing sick and injured people or maintaining public safety.

- **Use the FeliCa reader/writer function only in Japan.**

The FeliCa reader/writer function of the tablet conforms to the domestic radio wave standards. Using the function overseas may result in punishment.

- **Never change the basic software improperly.**

This may be regarded as a conversion of software and repairs may be refused.

- **Use the tablet at least 15 mm away from your body during data communication.**

Waterproof

SH-05G is waterproof to IPX5*1 and IPX7*2 standards if the docomo nano UIM card/microSD Card slot cover is securely closed.

*1 IPX5 means that tablet keeps functioning after being subjected to a jet flow (12.5 liters/min) discharged from a nozzle (inner diameter: 6.3 mm), from all directions (approximately 3 m from the tablet) for 3 minutes or more.

*2 IPX7 means that SH-05G tablet keeps functioning after it is slowly submerged to depth of 1 m in static tap water at room temperature, left there for approximately 30 minutes and then taken out.

What you can do with waterproof of SH-05G

- You can call without using an umbrella in the rain (for rainfall of approximately 20 mm per hour).
- You can rinse off dirt from the tablet. Wash the tablet with low-pressure water flow (6 liters/min or lower and tap water at room temperature (between 5°C and 35°C)), holding it approximately 10 cm below faucet or shower head. Wash by using only your hands, not a brush or sponge, with the docomo nano UIM card/microSD Card slot cover held in position. Drain the tablet before use ( P. 11 "Draining water when the tablet gets wet").
- You can use the tablet at a poolside. Do not throw water in a swimming pool on the tablet or soak the tablet in the water of a swimming pool.

Things to keep in mind

To maintain waterproof performance, check the followings.

- Securely close the docomo nano UIM card/microSD Card slot cover. Be careful not to apply excessive force on the rubber gasket when opening and closing.
- Make sure that the docomo nano UIM card/microSD Card slot cover is completely closed without floating.
- To maintain waterproof performance, the tablet has the docomo nano UIM card/microSD Card slot cover that allows you to close securely. Note that opening it forcibly may cause injuries to your nails, fingers, etc.
- For details on how to open/close the docomo nano UIM card/microSD Card slot cover  P. 14 "Inserting docomo nano UIM card"

● To maintain waterproof performance, replacement of parts is recommended every 2 years regardless of whether the tablet appears normal or abnormal. DOCOMO replaces the parts as a chargeable service. Bring the tablet to a repair counter that DOCOMO specifies.

Precautions

- When your hands or the tablet is wet, do not open/close the docomo nano UIM card/microSD Card slot cover.
- Close the docomo nano UIM card/microSD Card slot cover securely. Even a fine obstacle (one hair, one grain of sand, tiny fiber, etc.) put between contact surfaces may allow water to get inside.
- If the tablet gets wet with water or other liquids with the docomo nano UIM card/microSD Card slot cover opened, the liquid may get inside causing electric shocks or malfunction. Stop using the tablet, turn off the power and contact a repair counter that DOCOMO specifies.

Before Using the Tablet

Part names and functions

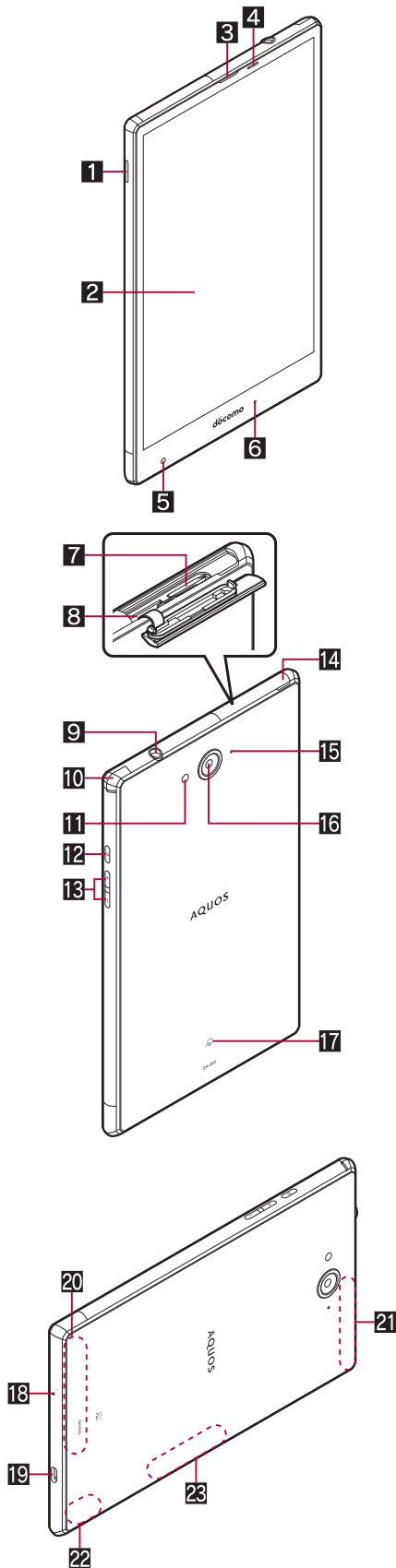

1 Speaker

- Ringtone, music, etc. can be heard from here.
- The other party's voice can be heard from here during a hands-free call.

2 Display/Touch panel

3 Earpiece

4 Proximity sensor/Brightness sensor*1

- The proximity sensor detects the distance to the face and prevents inadvertent operation of touch panel during a call.
- The brightness sensor detects the brightness of the surrounding area and adjusts the brightness of the backlight.

5 Front camera

6 Incoming/Charging lamp

7 docomo nano UIM card slot

- The tray for inserting the docomo nano UIM card is stowed.

8 microSD Card slot

9 Earphone/Microphone terminal

10 Mobacas/TV antenna

11 Mobile light

12 : Power key

- Use to turn the power on/off, etc.
- Use to turn the display on/off.

13 : Volume UP/DOWN key

- Adjusts the volume in each function.

14 docomo nano UIM card/microSD Card slot cover

15 Air vent

- A vent to remove excess air from the tablet.

16 Back camera

17 mark

- IC card is contained (It cannot be removed).

18 Mouthpiece/Microphone

19 External connector terminal

20 FOMA/Xi antenna*2

21 FOMA/Xi sub antenna*2

22 Wi-Fi/Bluetooth/GPS antenna*2

23 Wi-Fi/Bluetooth sub antenna*2

*1 Do not cover the sensor area with your hand or paste a sticker etc. on the sensor area. The sensor may not work properly.

*2 The antenna is built into the main body. Covering the antenna area with your hand may influence the quality.

Earphone/Microphone terminal

- For details on the corresponding earphone/microphone, refer to the following website.

http://k-tai.sharp.co.jp/support/d/sh05g/peripherals.html#!/earphone_support (in Japanese only)

Using desktop holder

When you use a Desktop Holder SH47 (sold separately), place the tablet in the direction of the arrow so that it fits the desktop holder.

Example: When the tablet is placed horizontally

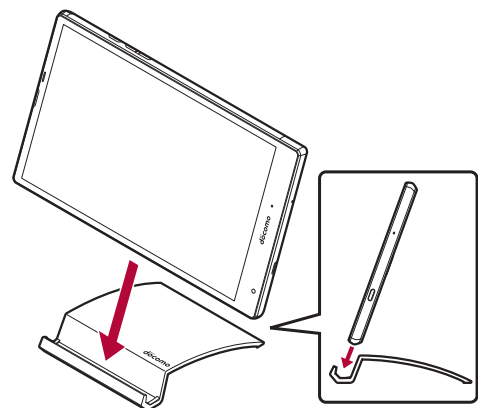

- If you do not connect an AC adapter (sold separately), a USB coaxial conversion cable SH01 (sold separately), etc. to the external connector terminal, you can also place the tablet on the desktop holder vertically.

IMEI plate

- A plate on which the IMEI number (International Mobile Equipment Identifier) is printed is stowed near the docomo nano UIM card slot and microSD Card slot. The IMEI number is required when you contact a repair counter that DOCOMO specifies, so do not pull it out.
- Note that pulling out the IMEI plate forcibly or adding forces on it may damage the plate.
- If you accidentally pull out the IMEI plate, push it back slowly in the direction of the docomo nano UIM card slot.

Charging

The internal battery is not fully charged at the time of purchase. Be sure to charge the battery before use.

■ Cautions while charging

- For details on the estimated charge time P. 93 “Main specifications”
- The battery can also be charged with the tablet turned on (While charging, the battery icon appears with [🔌] superimposed).
- Do not charge for a long time with the power left turned on. If the tablet is left turned on after charging is complete, the internal battery charge level decreases.
In this case, an AC or DC adapter (sold separately) charges the battery again. However, depending on the time when the tablet is disconnected from the AC or DC adapter, the battery charge level may be low or the battery may only be usable for a short time.
- If the tablet is left for a long time even after the charging is completed, the battery level may decrease.
- When the battery is empty and the tablet is being charged, the charging lamp may not illuminate immediately. However, charging is in progress.
- If the battery empty alert is displayed and the power cannot be turned on, charge the battery for a while.
- While charging, the tablet may not be turned on even when the charging lamp is illuminated in red. Charge longer and try turning the power on again.
- Frequently recharging the battery when its power is still remaining enough may shorten the usable life of the internal battery. It is recommended to use the battery to a certain level (e.g. after the battery level decreases) before recharging.
- When the battery becomes warm, charging may automatically stop even if the battery has not been fully charged. Charging automatically resumes after the temperature lowers to an appropriate temperature.
- If you watch Mobacas, receive content, etc. while charging, move the tablet as far away as possible from the power plug section of the AC adapter.

■ Estimated battery life when fully charged

Continuous talk time	FOMA/3G
	Approx. \$\$ min
	GSM
	Approx. \$\$ min
	VoLTE (Voice call)
	Approx. \$\$ min

Continuous stand-by time	FOMA/3G
	At rest: Approx. \$\$ hr (Preferred network type: LTE/3G/GSM(Auto))
	GSM
	At rest: Approx. \$\$ hr (Preferred network type: LTE/3G/GSM(Auto))
	LTE
	At rest: Approx. \$\$ hr (Preferred network type: LTE/3G/GSM(Auto))
Mobacas watching time	Approx. \$\$ min
TV watching time	Full-Seg: Approx. \$\$ min 1Seg: Approx. \$\$ min

- For details on the battery life P. 93 “Main specifications”

■ Internal battery usable life

- Internal battery is a consumable product. Battery life per charge is gradually reduced every time the battery is charged.
- When battery life per charge is reduced to approximately half of the default time, this means that the internal battery is approaching the end of its usable life. In this case, it is recommended to replace the battery as soon as possible. For details on replacing the internal battery, contact the number listed in “Repairs” (in Japanese only) on the last page or a repair counter that DOCOMO specifies.
- If you watch TV etc. while charging for a long time, the usable life of the internal battery may become shorter than estimated.



Li-ion00

■ AC adapter and DC adapter

- Refer to user's guide of AC Adapter 05 (sold separately) or DC Adapter 04 (sold separately).
- AC Adapter 05 covers from 100 to 240V AC.
- The shape of the plug for the AC adapter is for 100V AC (for domestic use). To use the AC adapter of 100 to 240V AC overseas, a conversion plug adapter applicable to your country of stay is required. Do not use a voltage converter for overseas travel to charge the battery.

Charging with AC adapter/DC adapter

[Read the user's guides of AC Adapter 05 (sold separately) and DC Adapter 04 (sold separately)]

- Following operations describe how to charge with AC Adapter 05 or DC Adapter 04.

1 Insert the microUSB plug of the AC adapter/DC adapter horizontally into the external connector terminal on the tablet with the side marked with “B” turned up

- Check the direction (front or rear) of the microUSB plug and insert it horizontally.

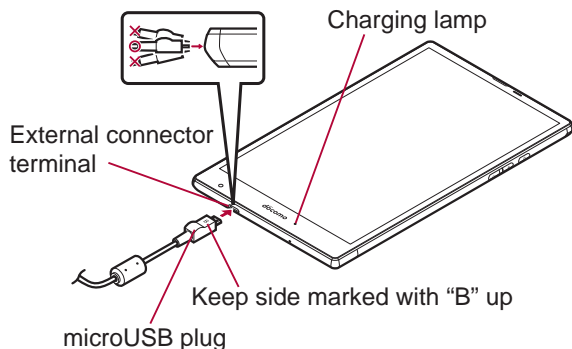

- 2 When you erect the AC adapter power plug and insert it into an outlet or insert the DC adapter power plug into a car cigarette lighter socket, the charging lamp illuminates and charging starts

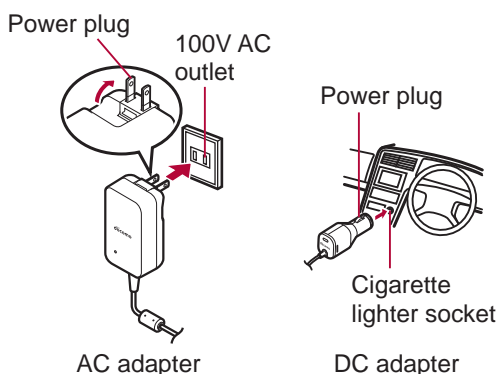

- 3 When charging is complete, the charging lamp turns off
- 4 Remove the AC adapter power plug from the outlet, or remove the DC adapter power plug from the car cigarette lighter socket
- 5 Remove the microUSB plug of the AC adapter/DC adapter horizontally from the external connector terminal

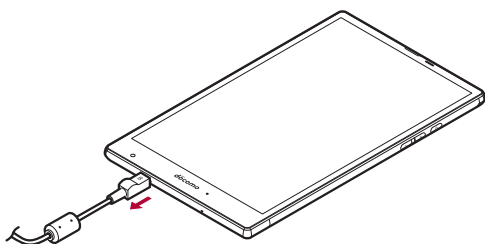

- Note that inserting or removing the equipment forcibly may cause damage to the external connector terminal and the microUSB plug or result in a malfunction.

When using a DC adapter

- The DC adapter should only be used in negative grounded vehicles (12 and 24V DC).
- Do not use with the car engine shut off. May drain the car battery.
- The DC adapter fuse is a consumable product. For replacement, purchase a new fuse at a nearest auto parts retailer etc.
- Refer to the user's guide of DC Adapter 04 for details.

Charging with Micro USB Cable 01

You can charge the tablet by connecting the tablet to a PC with **Micro USB Cable 01 (sold separately)**.

- For details on connecting to a PC P. 82 "Connecting the tablet and PC"

Turning power on/off

Turning power on

1 (for at least 2 seconds)

- When you turn the power on for the first time, make the initial settings (P. 21 "Initial settings").

Turning power off

1 (for at least 1 second) ▶ [Power off] ▶ [OK]

Turning power off forcibly

You can forcibly turn the power off if the screen does not respond or the power cannot be turned off.

1 (for at least 8 seconds)

- Release your finger after the vibrator is activated to turn the power off.

Turning display on/off

The display is turned off when is pressed or the tablet is not in use for a set length of time.

Press while the display is turned off to turn it on.

Touch panel lock

When the power or the display is turned on, the touch panel is locked.

Touch to unlock.



Operations in touch panel lock screen

- To set/disable the manner mode: (for at least 2 seconds)
- To turn on/off the mobile light: (for at least 2 seconds)
- To activate SH Camera:
- To activate シャベってコンシェル (Shabette-Concier):
- To display the detailed information on notifications: Drag the clock down
- To display the status panel: Drag the status bar down

- The notifications are displayed in the lock screen of the touch panel. You can make settings for displaying of notifications in [When device is locked] (P. 65 "Sound/notification").

Mobile light

- The mobile light may be automatically turned off if you use the tablet for a long time or the tablet becomes warm after the mobile light is turned on. Also, you may not be able to use the mobile light if the tablet is warm.

Basic operation

The followings describe basic operations of the tablet such as operations of the touch panel and navigation keys, and operations for shooting screenshot.

Operation of touch panel

The followings describe the operations to use the display (touch panel).

- Operations may differ depending on the function and screen in use.

Cautions when using the touch panel

- The touch panel is designed to be lightly touched with your finger. Do not forcefully press with your finger or a pointed object (fingernail, ballpoint pen, pin, etc.).
- In the following cases, the touch panel may not work even if you touch it. May cause a malfunction.
 - Operation with a gloved finger
 - Operation with the tip of a fingernail
 - Operation with foreign objects placed on the operation pad
 - Operation on the touch panel on which a protective sheet, sticker, etc. is put
 - Operation while the touch panel is wet
 - Operation with fingers wet with sweat, water, etc.

- Operations may be interrupted if you touch an area other than a confirmation screen or the status bar while the confirmation screen etc. is displayed.

Touch

Touch a key or an item displayed on the screen and then release your finger from it to select or set it.



Touch and hold

When you keep your finger on the touch panel, a menu may appear depending on the function and screen in use.

Slide (Swipe)/Drag

Move your finger while keeping it on the touch panel to scroll the screen or move an icon, a widget, etc. to the desired position. In addition, when you touch a menu or an item by mistake, move your finger away from it to cancel the selection.



Flick

Move your finger like sweeping the touch panel in the home screen etc. to switch pages.



Pinch out/Pinch in

You may be able to zoom the screen in/out etc. by putting two fingers on the touch panel and moving them with putting a distance between two fingers apart (pinch out)/closer (pinch in) depending on the function and screen in use.



Operation while using function

Navigation keys

Use the navigation keys displayed at the bottom of the screen to perform the basic operations.

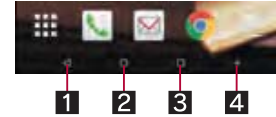

1 [Back key/Close key]

- Return to the previous screen.
- Close the keyboard.

2 [Home key]

- Display the home screen.

3 [Recent Apps key]

- Display Quick Launcher or Recent Apps (☞ P. 26 “Quick Launcher”, P. 28 “Recent Apps”).

4 [Trace to search or enlarge]

- Activate Trace to search or enlarge (☞ P. 28 “Trace to search”, P. 28 “enlarge”).

Using user-aid function

You can quickly activate apps supporting the user-aid function.

1 Slide any of the navigation keys up ▶ slide it to [Google]

- If there are multiple apps supporting the user-aid function, [Google] is displayed and you can select an app to activate.

Retrieving menu

When you touch [⋮]/[☰]/[☰] etc., slide the left edge of the screen to the right or touch and hold the screen, functions (menus) available in that screen appear.

Example: App screen



■ Initial settings for docomo service

- 1 When the initial settings screen for docomo service is displayed, [Agree to all] ▶ [Start settings]
- 2 Make the initial settings
 - The following items can be set.
 - docomo ID
 - docomo cloud
 - docomo apps password
 - docomo location information
 - Remote Initialization Service*
 - Install all apps
 - * This is not displayed when you have not set a docomo apps password.
- 3 [Start using]

Setting an access point

An access point (sp-mode) for Internet connection is registered by default. You can add other access points and change them if necessary.

For details on sp-mode, refer to the DOCOMO website.

If you want to use mopera U or Business mopera Internet, add an access point of either provider manually.

For details on mopera U, refer to the mopera U website.

■ Checking an access point in use

- 1 In the home screen, [⋮] ▶ [Settings] ▶ [More] ▶ [Cellular networks] ▶ [Access Point Names]

■ Setting additional access points

- Never set the MCC to a figure other than 440 or the MNC to a figure other than 10. Otherwise the added access point disappears from the screen.

- 1 In the home screen, [⋮] ▶ [Settings] ▶ [More] ▶ [Cellular networks] ▶ [Access Point Names] ▶ [⊕]
- 2 [Name] ▶ enter the name of the network profile to create ▶ [OK]
- 3 [APN] ▶ enter the access point name ▶ [OK]
- 4 Enter other items required by network operators ▶ [⋮] ▶ [Save]

- If the settings of MCC and MNC are changed and the added access point disappears from the screen, reset the settings or set the access point manually.

Resetting an access point

Reset an access point to default setting.

- 1 In the home screen, [⋮] ▶ [Settings] ▶ [More] ▶ [Cellular networks] ▶ [Access Point Names]
- 2 [⋮] ▶ [Reset to default]

- When sp-mode is not subscribed or if you fail to make automatic setting of an access point due to signal status such as outside the service area, you are required to set the access point again manually.

Wi-Fi settings

If you use Wi-Fi function of the tablet, you can use mail or Internet by connecting to access points of your home, corporate network or public wireless LAN service.

Radio interference with Bluetooth devices

- Wireless LANs (IEEE 802.11b/g/n) use the same frequency band (2.4 GHz) as Bluetooth devices. Therefore, using the wireless LAN device near a Bluetooth device may cause radio interference, lowering of communication speed, noise or connection failure. In this case, turn off the Bluetooth device or keep the tablet and the wireless LAN device at least approximately 10 m away from the Bluetooth device.

- Packet communication is also available while [Wi-Fi] is set to On. Wi-Fi connection is prioritized while Wi-Fi connection is set, but the connection is automatically switched to that of LTE/3G/GPRS network once Wi-Fi connection is terminated. Note that packet communication charges may be incurred in this case.
- Refer to the manual of your wireless LAN base unit when using the access point at home etc.
- Operate access point registration near the access point.
- If you use the docomo service by using Wi-Fi function, set a docomo ID in advance. In the home screen, [⋮] ▶ [Settings] ▶ [docomo service/cloud] ▶ [docomo ID設定] (Set docomo ID) to set it.

- 1 In the home screen, [⋮] ▶ [Settings] ▶ [Wi-Fi]

- 2 Set to On

- 3 Select an access point

- If you select an access point protected by security, enter the password (security key) and select [CONNECT].
- To register access points manually: [⋮] ▶ [Add network] ▶ enter the network name ▶ set security ▶ [SAVE]
- WPS compatible access points can be easily registered. In the home screen, [⋮] ▶ [Settings] ▶ [Wi-Fi] ▶ [⋮] ▶ [Easy Settings] ▶ [WPS Push Button]/[WPS Pin Entry] to register an access point.
- Alternatively, in the home screen, [⋮] ▶ [Settings] ▶ [Wi-Fi] ▶ [⋮] ▶ [Easy Settings] ▶ [AOSS] to connect to an access point. Follow the instructions on the screen and operate after this step.

- When you select an access point and connect to it with a wrong password (security key), [Avoided poor Internet connection], [Authentication problem] or [Connected (Limited)] is displayed. Confirm the password (security key). When [Avoided poor Internet connection] or [Connected (Limited)] is displayed after entering the correct password (security key), you may not have acquired the correct IP address. Connect to the access point again after confirming signal status.
- The registration process using WPS takes a few minutes. After completion of the registration of the access point, check that the proper connection to the access point is acquired.
- As for the manual registration of an access point, this function supports WEP, WPA/WPA2 PSK and 802.1x/EAP as the security setting.
- If you connect to an access point which is not connected to the Internet, [⋮] is displayed and the communication may be made by mobile networks, not Wi-Fi connection. To make Wi-Fi communication by using such an access point, enable [Using this AP without internet connection] of Advanced options before connecting to the access point.

■ Detailed settings

1 In the home screen, [⋮] ▶ [Settings] ▶ [Wi-Fi]

2 [⋮] ▶ [Advanced]

3 Select an item

- **Network notification:** Set whether to display a notification icon when an open network is detected.
 - Set it after setting [Wi-Fi] is set to On.
- **Scanning always available:** Set whether to scan networks by the location information service and other apps even when [Wi-Fi] is set to Off.
- **Wi-Fi sleep policy:** Set whether to disconnect Wi-Fi when the display is turned off.
- **Avoid poor connections:** Set whether to use the Wi-Fi function only when stable Internet connections are available.
- **Wi-Fi frequency band:** Set the frequency band to use.
- **Handover:** Set whether to automatically switch access points to use if you use the tablet while moving.
- **Mobile/Wi-Fi simultaneous use:** Make settings for simultaneous use of mobile and Wi-Fi networks.
- **Install certificates:** Install certificates.
- **Wi-Fi Direct:** Make settings for Wi-Fi Direct.
- **Passpoint:** Set whether to automatically connect to the available Passpoint compatible access points when [Wi-Fi] is set to On.
- **MAC address:** Confirm the MAC address.
- **IP address:** Confirm the IP address.

[Handover]

- You can set it only when you select [2.4 GHz only] of Wi-Fi frequency band and [Setting OFF] of Simultaneous use mode setting.

■ Mobile/Wi-Fi simultaneous use

You can make settings for the function to automatically switch to mobile networks when communications with Wi-Fi access points slow down (Smooth change mode) or the function to download content at high speed using mobile and Wi-Fi networks at the same time (Dual Speed mode).

- Set [Wi-Fi] to On and connect to an access point in advance.
- Since packet communication is also used when you use mobile and Wi-Fi networks at the same time, packet communication charges may be incurred.

1 In the home screen, [⋮] ▶ [Settings] ▶ [Wi-Fi]

2 [⋮] ▶ [Advanced]

3 [Mobile/Wi-Fi simultaneous use]

4 Select an item

- **Simultaneous use mode setting:** Set a mode to use.
- **Advanced settings:** Make settings for applicable access points and apps, and inapplicable servers.
- **Notes:** Check the precautions.
 - Touch [?] of an item to display its explanations.

■ Disconnecting

1 In the home screen, [⋮] ▶ [Settings] ▶ [Wi-Fi]

2 Select the connected access point ▶

[Disconnect]

- Disconnect with the password retained. The access point may be automatically connected again such as when the display is turned on.

Tethering

You can use the tethering function that connects Wi-Fi compatible devices, or PCs etc. connected via Micro USB Cable 01 (sold separately) or Bluetooth communication to the Internet by using the tablet as an access point.

- You can connect up to \$\$ devices in total at the same time: \$\$ PC connected via Micro USB Cable 01, \$\$ Wi-Fi compatible devices and \$\$ Bluetooth devices.
- The tablet supports dial-up connections via DUN profile.
- Before using Bluetooth tethering, register the other party's Bluetooth device in advance (☞ P. 80 "Using Bluetooth function").
As for the settings on the Bluetooth device, refer to its manual.

1 In the home screen, [⋮] ▶ [Settings] ▶ [More] ▶ [Tethering]

2 Select an item

- **USB tethering:** Set whether to use the USB tethering.
- **Wi-Fi tethering:** Set whether to use the Wi-Fi tethering.
- **Set up Wi-Fi hotspot:** Make settings for Wi-Fi tethering such as network name and security.
- **Wi-Fi tethering Easy Connection:** Set whether to use the tethering by connecting to WPS compatible access points.
- **Bluetooth tethering:** Set whether to use the Bluetooth tethering.

[USB tethering]

- The tethering function is available on Windows Vista, Windows 7, Windows 8, Windows 8.1 and Linux.
- A microSD Card inserted in the tablet cannot be mounted on a PC during USB tethering.
- For details on USB tethering, refer to the following website.
<http://www.android.com/tether#usb>

[Wi-Fi tethering]

- While the tablet is functioning as an access point, it cannot access the Internet via Wi-Fi connection.
- Make settings for Wi-Fi access points in [Set up Wi-Fi hotspot].
- For details on Wi-Fi tethering, refer to the following website.
<http://www.android.com/tether#wifi>

[Set up Wi-Fi hotspot]

- At the time of purchase, Network name is set to [SH-05G_AP] and Security is set to [WPA2 PSK] while Password is set randomly. Change the settings if necessary.

Setting up mail account

1 In the home screen, [⋮] ▶ [Email]

- Only when an account is not set up, the account setup screen appears.

2 Enter mail address ▶ [▶]

3 Enter password ▶ [▶]

- Provider information is preset for some mail accounts, and a receiving mail server and a sending mail server are automatically set.
- When you use an account whose provider information is not preset, it is necessary to set a receiving mail server and a sending mail server manually. For details on those settings, contact the Internet service provider you use.

4 Set up an account ▶ [▶]

5 Enter an account name and your name ▶ [▶]

You can use the phone and phonebook, and make settings for call, voice/answering memo, operations available when calls are received, etc.

Making a call

1 In the home screen, [☎] ▶ [Dial]

2 Enter a phone number

- Always enter the city code, even when it is a local number.
- You can set to notify/not to notify the other party of your phone number for each call by adding "186"/"184" to the head of the phone number.



1 Call

- Make a call. Also, if there are outgoing call history items, touch it to enter the latest one when the phone number has not been entered.

2 Favorites

- Display the contacts set as favorites.

3 Delete

- Delete an entered number.
- Touch and hold it to delete all the entered numbers.

4 Register

5 Dial

- Display the dial screen.

6 Outgoing/Incoming call history

7 Phonebook

- Display the phonebook.

3 [☎]

- To make a video call: [☎] ▶ [Video call]

4 [End call] to end the call

- If you talk on the tablet with your hair put between the earpiece and your ear, the proximity sensor may not work properly. The screen may be kept turned on and the call may be interrupted when the screen is touched accidentally.

VoLTE

- VoLTE enables you to use call and video call of high quality.
- When you use VoLTE, the tablet and the other party's device need to satisfy the following conditions.
 - They are VoLTE compatible models
 - They are inside the Xi service area*
 - Preferred network type is set to [LTE/3G/GSM(Auto)]/[LTE/3G] (☎ P. 85 "Preferred network type")
 - Call mode setting is set to [VoLTE/3G] (☎ P. 37 "Call settings/Other")

* VoLTE is not available outside the Xi service area or during international roaming.

Entering touch-tone signals

When using services in which you are required to enter numbers additionally during a call, such as inquiry about the balance in your bank account or ticket reservation, enter pause (,)/wait (;) after entering a phone number to make a call with an additional number added to the main phone number.

■ Adding 2 seconds pause

After making a call to a main phone number, the tablet automatically pauses for 2 seconds and an additional number is sent.

1 In the home screen, [☎] ▶ [Dial]

2 Enter a phone number ▶ [⋮] ▶ [Add 2-sec pause]

3 Enter a number to send ▶ [☎]

■ Adding wait

After making a call to a main phone number, the tablet automatically waits and then a screen asking whether to send an additional number is displayed. Touch [Yes] to send an additional number.

1 In the home screen, [☎] ▶ [Dial]

2 Enter a phone number ▶ [⋮] ▶ [Add wait]

3 Enter a number to send ▶ [☎]

4 [Yes] during the call

Video call

By using video call, you and the other party can talk on the tablet while seeing each other's image. Also, you can switch between voice call and video call while talking on the tablet.

- Call charges and packet communication charges are incurred when making a video call. In addition, packet communication charges are incurred also when receiving a video call.
- Quality of image may differ depending on the usage environment because suitable communication levels are applied according to the usage condition.
- If you cannot switch to a video call during a voice call, [Switching to video call failed] is displayed and the voice call continues.
- Be careful not to cover the speaker section during a video call. The other party's voice may not be heard well.
- While using video call in the background, your image is not sent to the other party.
- As for image displayed during a video call, since processes for displaying image may differ depending on the model to use, ranges of your image displayed on the tablet may differ from those displayed on the other party's device.

Emergency call

Emergency calls	Phone number
Police	110
Fire and ambulance	119
Marine emergency	118

- The tablet supports "Emergency call location notification". When you make a call to an emergency number such as 110, 119 and 118, the information of your location (location information) is automatically notified to the agency that has received the emergency call (e.g. the police station). Depending on your location and the reception status of the signal, the agency that has received the emergency call may not be able to confirm the exact location. If you are not sending your caller ID by calling with "184" added or other means, your location information and phone number are not notified. However, if the agency that has received the emergency call considers your location information and phone number necessary for important purposes, such as life saving, the agency may retrieve them regardless of your settings. In addition, the area/timing to introduce "Emergency call location notification" depends on the state of preparation in each agency that receives emergency calls.
- In Japan, you cannot make a call to the emergency number (110, 119 or 118) when a docomo nano UIM card is not inserted, while the PIN code is locked, from the PUK (PIN Unlock Key) entry screen.
- When calling 110, 119 and 118 from your tablet, the police or fire stations may return your call for verification purposes. State that you are calling from a mobile phone, and give your phone number and exact present location. Remain stationary to ensure that the call is not disconnected while you are on the line, and keep the tablet turned on to receive calls for approximately 10 minutes afterwards.
- Depending on the region, calls to the police or fire station of the local area may not be made.
- When you make a call to the emergency number (110, 119 or 118) while Reject call setting is set, items of Reject call setting are set to [OFF].
- Emergency call may not be available in some networks.
- You cannot make a video call to the emergency number (110, 119 or 118).

International call (WORLD CALL)

WORLD CALL is an international calling service available from DOCOMO devices in Japan.

- To make an international call through a company other than DOCOMO, contact the respective companies for instructions.
- The caller ID may not be notified or displayed correctly depending on overseas network operators. In this case, making a call with incoming call history is not available.

[Calling Method]

- When calling to a land-line phone: 010 ▶ country code ▶ area code (city code) ▶ the other party's phone number ▶ [☎]
- When calling to a mobile phone: 010 ▶ country code ▶ the other party's mobile phone number ▶ [☎]
- As for the other parties' mobile phone numbers and area codes (city codes) that begin with "0", omit the first "0" when entering (except some countries or regions such as Italy).
- Alternatively, enter "009130-010" as usual or "+" instead of "010".

Answering a call

- 1 When a call is received, the ringtone sounds and the incoming lamp flashes

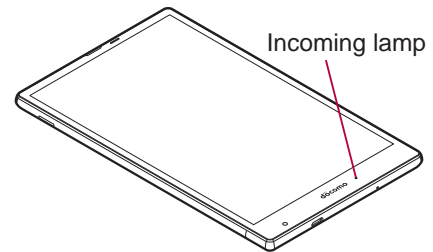

- 2 Answer the call

- Operate after touching [📞].

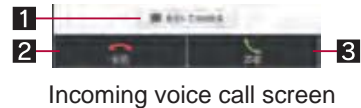

Incoming voice call screen



Incoming video call screen

1 Reject call with SMS

- Reject the incoming call and send a selected SMS message to the other party.

2 Reject

- Reject the incoming call.

3 Accept

- Answer the call.

4 Accept voice

- Answer the call using voice call.

5 Accept video

- Answer the call using video call.

- 3 [End call] to end the call

■ Answering a call while display is turned on

When a call is received while a screen other than lock screen of the touch panel is displayed, the incoming notification is displayed. You can answer the call by using the notification.

- 1 When a call is received, the incoming notification is displayed at the top of the screen

- 2 [ACCEPT]/[ACCEPT VIDEO]

- Touch the incoming notification to display incoming voice call/video call screen.
- Flick the incoming notification to the left/right to hide the notification.

■ Placing a call on hold

- 1 When a call is received, the ringtone sounds and the incoming lamp flashes

- 2 [⏸] ▶ [Put a caller on hold]

■ Answering a video call without sending your own image

- 1 When a video call is received, the ringtone sounds and the incoming lamp flashes

- 2 [⏸] ▶ [Camera OFF response]

- 1 Account
- 2 Group icon
- 3 Group name
- 4 Add group
 - Add a group.
- 5 Groups
- 6 Number of contacts registered in the group
- 7 Sort

● You cannot sort groups other than ones created with a docomo account.

■ Grouping/Ungrouping contacts

- 1 In the home screen, select “ドコモクラウド” (docomo cloud) folder ▶ [docomo phonebook] ▶ [Group]
- 2 Select a group
- 3 [Delete member]/[Add member]
- 4 Select names ▶ [OK] ▶ [OK]

● The group function is available on contacts created with a docomo/Google account etc.

My profile

You can display your phone number registered on the docomo nano UIM card. You can also register your name, mail addresses, etc.

- 1 In the home screen, select “ドコモクラウド” (docomo cloud) folder ▶ [docomo phonebook] ▶ [My profile]
- 2 Check/Use the profile



- 1 Image
- 2 Registered content
- 3 Notice
 - Make settings for Friends notice.
 - Available only when you are using cloud computing.
- 4 Edit

■ Editing My profile

- 1 In the home screen, select “ドコモクラウド” (docomo cloud) folder ▶ [docomo phonebook] ▶ [My profile]
- 2 [Edit]
- 3 Set each item ▶ [Save]

Backing up/Restoring phonebook

You can back up/restore the phonebook by using docomo backup.

- For details on backing up/restoring phonebook by using docomo backup 参考 P. 64 “Backing up to/Restoring from a microSD Card”

Mail/Web Browser

You can send and receive messages using docomo mail, SMS, Gmail, etc., and display websites using Chrome.

docomo mail

You can send and receive mails using mail address of DOCOMO (@docomo.ne.jp). Pictograms and Deco-mail are available. Automatic reception is also supported. Mails can be easily transferred when you have lost the tablet or changed models since sent and received mails are saved on the docomo mail server. Moreover, you can use the mailing function on PCs, tablets, etc. if you use a docomo ID.

- For details on docomo mail, refer to the DOCOMO website.

1 In the home screen, [✉]

- Follow the instructions on the screen and operate after this step.

SMS

You can send and receive text messages with mobile phone numbers serving as destinations.

※ For details on the number of characters which can be sent and received etc., refer to “Short Message Service (SMS)” on the DOCOMO website.

- You can also exchange messages with those who use network of overseas network operators. Refer to the DOCOMO website for information on countries where this service is available and available overseas network operators.

1 In the home screen, [☰] ▶ [Messaging]

2 [NEW MESSAGE]

3 Enter the destination and message ▶ [➤]

- You can switch Default SMS app to Hangouts (P. 70 “More”).
- If destinations are devices owned by those who use network of overseas network operators, enter “+”, the country code and the recipient’s mobile phone number. If the phone number begins with “0”, omit the first “0”. Alternatively, enter “010”, the country code and the phone number.
- Half-width katakana and special symbols in SMS messages may not appear correctly for recipient.
- SMS cannot be sent when “186” or “184” is added.

Displaying message

1 In the home screen, [☰] ▶ [Messaging]

2 Select a thread

- Messages are grouped into threads according to their destinations/senders and displayed.

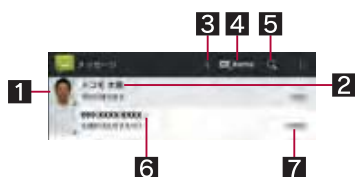

1 Image

- Displayed if an image of the other party is registered in the phonebook. Touch to select and use an app supporting the registered content of the phonebook. If the person is not registered in the phonebook, you can register the person in the phonebook after touching it.

- 2 Destination/Sender
- 3 Number of unread messages
- 4 NEW MESSAGE
- 5 Mail search
- 6 Number of messages in thread
- 7 Date and time of the message exchange

3 Check the message



- 1 Destination/Sender
- 2 Phone call
- 3 Date and time of the message exchange
- 4 Message

Replying message

1 In the home screen, [☰] ▶ [Messaging]

2 Select a thread

3 Enter the message ▶ [➤]

Forwarding message

1 In the home screen, [☰] ▶ [Messaging]

2 Select a thread

3 Touch and hold a message ▶ [Forward]

4 Enter the destination and message ▶ [➤]

Deleting message

1 In the home screen, [☰] ▶ [Messaging]

2 Select a thread

3 Touch and hold a message ▶ [Delete] ▶ [Delete]

Deleting thread

1 In the home screen, [☰] ▶ [Messaging]

- To delete all threads: [⋮] ▶ [Delete all threads] ▶ [Delete]

2 Touch and hold a thread ▶ [DELETE] ▶ [Delete]

Setting Messaging

1 In the home screen, [☰] ▶ [Messaging]

2 [⋮] ▶ [Settings]

3 Select an item

- **SMS Enabled:** Set an app to send and receive SMSs with.

- **Delete old messages:** When the number of saved messages reaches its limit, messages are automatically deleted from the oldest one.
- **Text message limit:** Set the number of messages to be saved by thread.
- **Delivery reports:** Notify you that sent messages have been received every time a message is received.
- **Manage SIM card messages:** Manage messages saved on the docomo nano UIM card.
- **Notifications:** Notify you that messages have been received on the status bar.
- **Sound:** Set the ringtone to be rung when a message is received.
- **Vibrate:** Set the vibrator to be activated when a message is received.

[Delivery reports]

- When you send a message to mobile phones of other carriers, the notification for confirming that it has been received may not be sent to you.

Email

You can send and receive mails by setting up a mail account provided by a service provider.

- Set up an account in advance (☞ P. 23 “Setting up mail account”).

1 In the home screen, [] ▶ [Email]

2 []

3 Compose a mail



1 Account

- If you set up multiple accounts, you can switch accounts.

2 Destination

- When you enter part of a mail address or a name registered in the phonebook, destination candidates are displayed.

3 Subject

4 Message

5 File attachment

6 Add destinations

- Touch it to add Cc or Bcc.

4 []

- Some receiving side models may not be able to receive the subject completely.
- Mails sent from a Gmail account are treated as ones from a PC. When receiving side models set PC-mail rejection, mails cannot be sent.
- Mails that could not be sent for any reason will be saved in Unsent folder as unsent mails.
- Depending on the signal status etc., characters may not appear correctly on the screen of the other party's device.

Attaching file

- Files of up to approximately 5 MB can be attached. There are no limits to the number of files to be attached.
- Depending on the receiving side device, files may not be received or correctly displayed/played. Also, the quality of videos may deteriorate or videos may be converted to continuous still pictures.

Displaying mail

- The screen may appear different depending on the account to use.

1 In the home screen, [] ▶ [Email]

2 Select a mail



1 Box name/Folder name being displayed

- Touch [] to switch or set folders/accounts.

2 Panel menu

- Display the icon of the account being used.
- Touch a displayed icon to switch folders.

3 Switch accounts

- If you set up multiple accounts, you can switch accounts.

4 Mail search

5 Mails

- The characters of sender or subject are displayed in thin characters when a mail is read.
- Touch images to checkmark the mails and you can set them to be deleted/unread/read etc. collectively.

6 Star icon

- Use it as a mark indicating that the mail is special or supposed to be dealt with later.
- You can check starred mails in the Starred folder.

7 Newly compose mail

3 Check the mail



1 Subject

2 Sender/Destination

- If the sender is registered in the phonebook, available apps supporting the registered content of the phonebook are displayed after touching the image. If the person is not registered in the phonebook, you can register the person in the phonebook after touching the image.

3 Date and time of reception

- Touch to display/hide the details of sender, destination or data and time of reception.

4 Message

5 Attached file

6 Star icon

- Use it as a mark indicating that the mail is special or supposed to be dealt with later.
- You can check starred mails in the Starred folder.

7 Menu of each mail

- Touch to reply to all or print by mail.

8 Forward

9 Reply

10 Delete

11 Unread

Replying/Forwarding mail

1 In the home screen, [☰] ▶ [Email]

2 Select a mail

3 [↶]

- To reply to all: [⋮] of each mail ▶ [Reply all]
- To forward: [➡]

4 Compose a mail



1 Reply type

- Touch to switch Reply/Reply all/Forward.

2 Destination

3 Message

4 Quote text

- Touch to display/hide the mail of the sender.
- You cannot operate it when forwarding mails.

5 Mail of sender

6 Subject

7 Respond inline

- Enter the mail of the sender in the message.

5 [➤]

Deleting mail

1 In the home screen, [☰] ▶ [Email]

- To delete selected mails: Touch the images of mails ▶ [🗑️] ▶ [OK]

2 Select a mail

3 [🗑️] ▶ [OK]

Setting Email

1 In the home screen, [☰] ▶ [Email]

2 [☰] ▶ [Settings]

3 Select an item

- **General settings:** Make settings for the whole Email.

- **Add account:** Add account.

- **Privacy policy:** Check the privacy policy.

- Select an account to make settings for the details on the account such as Signature and Email notifications.

Gmail

Gmail is a mail service provided by Google.

- Set up a Google account in advance (☞ P. 24 “Setting up Google account etc.”).

1 In the home screen, select “Google” folder ▶ [Gmail]

2 [🔍]

3 Compose a mail



1 Account

- If you set up multiple accounts, you can switch accounts.

2 Destination

- When you enter part of a mail address or a name registered in the phonebook, destination candidates are displayed.

3 Subject

4 Message

5 File attachment

6 Add destinations

- Touch to add Cc or Bcc.

4 [➤]

Displaying mail

1 In the home screen, select “Google” folder ▶ [Gmail]

2 Select a thread

- In Gmail, mails are grouped into threads by reply and displayed. If new mails are replied ones of an existing mail, they are grouped into the same thread. A new thread is created for newly composed mails or mails whose subjects have been changed.



1 Box name/Label name being displayed

- Touch [☰] to switch or set displaying types/accounts.

2 Panel menu

- Display the icon of the account being used.
- Touch a displayed icon to switch displaying types.

3 Switch accounts

- If you set up multiple accounts, you can switch accounts.

Using Bluetooth function

- To register/connect a Bluetooth device, the Bluetooth passkey may need to be entered. Before starting the registration, decide one- to sixteen-digit number. Enter the same number on the tablet and the other party's Bluetooth device.
- Set the other party's Bluetooth device to the registration stand-by status in advance.

1 In the home screen, [] ▶ [Settings] ▶ [Bluetooth]

2 Set to On

3 Select a Bluetooth device ▶ [PAIR]

- The confirmation screen for connection may be displayed.
- Entering the Bluetooth passkey may be necessary depending on the other party's Bluetooth device. Also, some Bluetooth devices may start connection after completing registration.
- To search for Bluetooth devices: [] ▶ [Refresh]
- Touch [] of a paired Bluetooth device to set name and intended purpose of the other party's Bluetooth device.

- You can connect up to seven Bluetooth devices at the same time. Bluetooth devices may not work properly or the number of Bluetooth devices which can be connected at the same time may differ depending on the profile.

- If you fail to connect a Bluetooth device, connection may become available after re-registering it.
- When [Bluetooth] is set to On, the tablet is set to receive registration requests/connection requests from other Bluetooth devices. Make the setting for displaying the tablet's information on other Bluetooth devices in advance to allow the tablet to be searched for by other Bluetooth devices.
- While in connection stand-by, even if a connection request from a Bluetooth device is received, connection may not be made depending on the signal status etc.
- For details on the operations of the other party's Bluetooth device, refer to the manuals of the Bluetooth device to be used.

■ When receiving registration request from Bluetooth device or connection request from unregistered Bluetooth device

1 Registration request/Connection request from Bluetooth device

2 Drag the status bar down ▶ [Pairing request] ▶ [PAIR]

- When the confirmation screen about the settings on pairing appears, select [PAIR].
- Entering the Bluetooth passkey may be necessary depending on the other party's Bluetooth device.
- The confirmation screen for connection may be displayed.

■ Unregistering Bluetooth device

1 In the Bluetooth screen, [] of the Bluetooth device to unregister ▶ [FORGET]

■ Disconnecting Bluetooth device

1 In the Bluetooth screen, select the Bluetooth device to disconnect ▶ [OK]

■ Setting Bluetooth

- Set after setting [Bluetooth] to On.

1 In the Bluetooth screen, []

2 Select an item

- **Refresh:** Search for the Bluetooth device.
- **Rename this device:** Change the tablet's name.
- **aptX:** Set whether to use aptX®.
- **Handsfree setting:** Set whether to always have voices output from the connected Bluetooth compatible hands-free device during a voice call.
- **Show received files:** Display the history of data received via Bluetooth connection.

[aptX]

- When you enable [aptX], sounds may not be output depending on the Bluetooth device. In this case, disable [aptX].

Sending and receiving by Bluetooth

■ Sending data

Example: Still picture

1 In the home screen, [] ▶ [Contents Manager] ▶ [Photo]

2 Touch and hold a still picture ▶ [Share] ▶ [Bluetooth]

- Set the receiver's Bluetooth device to the reception stand-by status.

3 Select a Bluetooth device to connect to

■ Receiving data

1 Data is sent from the sender's Bluetooth device

2 Drag the status bar down ▶ select the incoming notification ▶ [ACCEPT]

3 Drag the status bar down ▶ select the received data

- Note that if you select [Delete and register] when receiving all data, all data registered to the target function are deleted.
- Receiving all data may not be available depending on the data type.
- When available space in the save destination becomes insufficient while receiving data, the data being received to that point are saved and receiving ends.

- *2 Talk (Communication)/Stand-by time is shortened with the frequent use of each function such as data communications, Multiaccess, camera function, TV function or Bluetooth function. Actual usage time is the combination of talk (communication) and stand-by time. The longer the talk time is, the shorter the stand-by time becomes.
- *3 Talk (Communication)/Stand-by time may be reduced by approximately half or Mobacas watching time/TV watching time may be shortened depending on conditions including the battery level status, functions used, temperature or other environmental conditions, and signal strength (no signal or weak signal).
- *4 This is the average usage time during which the tablet is not carried with you and in a status where signals are received normally.
- *5 Mobacas watching time is an estimate of watching time in a status where signals are received normally.
- *6 TV watching time is an estimate of watching time in a status where signals are received normally.
- *7 CMOS (Complementary metal-oxide semiconductor) is an image device equivalent to the film of silver salt cameras.
- *8 Picture size: \$\$ (\$\$x\$\$)/File size: Approx. \$\$ KB
- *9 Picture size: \$\$ (\$\$x\$\$)/File size limit: \$\$ GB/Type: \$\$
- *10 Depending on usage of apps which use common memory, the memory capacity of each data may be reduced.
- *11 MIMO is supported.
- *12 MU-MIMO (Client mode) is supported.

■ Internal battery

Battery	Lithium-ion
Nominal voltage	\$\$V DC
Nominal capacity	\$\$ mAh

Recording time of voice recorder

Save destination	Number of entries	Recording time
Tablet memory (approx. \$\$ GB)*	Up to \$\$	Up to approx. \$\$ hr

* Each recording time is up to approximately \$\$ hours.

Specific Absorption Rate (SAR) of Mobile Phones

This model SH-05G mobile phone complies with Japanese technical regulations and international guidelines regarding exposure to radio waves.

This mobile phone was designed in observance of Japanese technical regulations regarding exposure to radio waves (*1) and limits to exposure to radio waves recommended by a set of equivalent international guidelines. This set of international guidelines was set out by the International Commission on Non-Ionizing Radiation Protection (ICNIRP), which is in collaboration with the World Health Organization (WHO), and the permissible limits include a substantial safety margin designed to assure the safety of all persons, regardless of age and health condition.

The technical regulations and international guidelines set out limits for radio waves as the Specific Absorption Rate, or SAR, which is the value of absorbed energy in any 10 grams of tissue over a 6-minute period. The SAR limit for mobile phones is 2.0 W/kg. The highest SAR value for this mobile phone when tested for use at the ear is 0.258 W/kg and when worn on the body is 0.328 W/kg (*2). There may be slight differences between the SAR levels for each product, but they all satisfy the limit.

The actual SAR of this mobile phone while operating can be well below that indicated above. This is due to automatic changes to the power level of the device to ensure it only uses the minimum required to reach the network. Therefore in general, the closer you are to a base station, the lower the power output of the device. This mobile phone can be used in positions other than against your ear. Please keep the mobile phone farther than 1.5 cm away from your body by using such as a carrying case or a wearable accessory without including any metals. This mobile phone satisfies the technical regulations and international guidelines.

The World Health Organization has stated that “a large number of studies have been performed over the last two decades to assess whether mobile phones pose a potential health risk. To date, no adverse health effects have been established as being caused by mobile phone use.”

Please refer to the WHO website if you would like more detailed information.

http://www.who.int/docstore/peh-emf/publications/facts_press/fact_english.htm

Please refer to the websites listed below if you would like more detailed information regarding SAR.

Ministry of Internal Affairs and Communications Website:

<http://www.tele.soumu.go.jp/e/sys/ele/index.htm>

Association of Radio Industries and Businesses Website:

<http://www.arib-emf.org/01denpa/denpa02-02.html> (in Japanese only)

NTT DOCOMO, INC. Website:

<https://www.nttdocomo.co.jp/english/product/sar/>

SHARP Corporation Website:

<http://k-tai.sharp.co.jp/support/sar/> (in Japanese only)

*1 Technical regulations are defined by the Ministerial Ordinance Related to Radio Law (Article 14-2 of Radio Equipment Regulations).

*2 Including other radio systems that can be simultaneously used with Xi/FOMA.

European RF Exposure Information

Your mobile device is a radio transmitter and receiver. It is designed not to exceed the limits for exposure to radio waves recommended by international guidelines. These guidelines were developed by the independent scientific organization ICNIRP and include safety margins designed to assure the protection of all persons, regardless of age and health.

The guidelines use a unit of measurement known as the Specific Absorption Rate, or SAR. The SAR limit for mobile devices is 2 W/kg and the highest SAR value for this device when tested at the ear is 0.179 W/kg* and when worn on the body is 0.398 W/kg*. For body-worn operation, this mobile device has been tested and meets the RF exposure guidelines when used with an accessory containing no metal and positioning the device a minimum of 1.5 cm from the body. Use of other accessories may not ensure compliance with RF exposure guidelines.

As SAR is measured utilizing the devices highest transmitting power the actual SAR of this device while operating is typically below that indicated above. This is due to automatic changes to the power level of the device to ensure it only uses the minimum level required to reach the network.

* The tests are carried out in accordance with international guidelines for testing.

Declaration of Conformity

CE0168

In some countries/regions including Europe, there are restrictions on the use of 5GHz WLAN that may limit the use to indoors only. If you intend to use 5GHz WLAN on the device, check the local laws and regulations beforehand.

Hereby, Sharp Telecommunications of Europe Ltd, declares that this SH-05G is in compliance with the essential requirements and other relevant provisions of Directive 1999/5/EC. A copy of the original declaration of conformity can be found at the following Internet address:
<http://www.sharp.co.jp/k-tai/> (in Japanese only)

FCC Notice

- This device complies with part 15 of the FCC Rules. Operation is subject to the following two conditions:
(1) This device may not cause harmful interference, and (2) this device must accept any interference received, including interference that may cause undesired operation.
- Changes or modifications not expressly approved by the manufacturer responsible for compliance could void the user's authority to operate the equipment.

Information to User

This equipment has been tested and found to comply with the limits of a Class B digital device, pursuant to Part 15 of the FCC Rules. These limits are designed to provide reasonable protection against harmful interference in a residential installation. This equipment generates, uses and can radiate radio frequency energy and, if not installed and used in accordance with the instructions, may cause harmful interference to radio communications.

However, there is no guarantee that interference will not occur in a particular installation; if this equipment does cause harmful interference to radio or television reception, which can be determined by turning the equipment off and on, the user is encouraged to try to correct the interference by one or more of the following measures:

1. Reorient/relocate the receiving antenna.
2. Increase the separation between the equipment and receiver.
3. Connect the equipment into an outlet on a circuit different from that to which the receiver is connected.

4. Consult the dealer or an experienced radio/TV technician for help.

5 GHz WLAN Operation in USA

Within the 5.15-5.25 GHz band, UNII devices are restricted to indoor operations to reduce any potential for harmful interference to co-channel Mobile Satellite Services (MSS) operations.

FCC RF Exposure Information

Your device is a radio transmitter and receiver.

It is designed and manufactured not to exceed the emission limits for exposure to radio frequency (RF) energy set by the Federal Communications Commission of the U.S. Government.

The guidelines are based on standards that were developed by independent scientific organizations through periodic and thorough evaluation of scientific studies. The standards include a substantial safety margin designed to assure the safety of all persons, regardless of age and health.

The exposure standard for wireless devices employs a unit of measurement known as the Specific Absorption Rate, or SAR. The SAR limit set by the FCC is 1.6 W/kg.

The tests are performed in positions and locations (e.g., at the ear and worn on the body) as required by the FCC for each model. The highest SAR value for this device when tested for use at the ear is less than 0.19 W/kg and when worn on the body, as described in this user guide, is 0.92 W/kg.

For body worn operation, this device has been tested and meets the FCC RF exposure guidelines. Please use an accessory designated for this product or an accessory which contains no metal and which positions the handset a minimum of 1.5 cm from the body.

The use of accessories that do not satisfy these requirements may not comply with FCC RF exposure requirements, and should be avoided.

The FCC has granted an Equipment Authorization for this device with all reported SAR levels evaluated as in compliance with the FCC RF emission guidelines. SAR information on this device is on file with the FCC and can be found under the Display Grant section of (<http://transition.fcc.gov/oet/ea/fccid/>) after searching on FCC ID APYHRO00222.

Additional information on Specific Absorption Rates (SAR) can be found on the FCC website at (<http://www.fcc.gov/encyclopedia/radio-frequency-safety/>).

FCC ID Location

The device is electronically labeled and the FCC ID can be displayed via the About tablet & the Authentication under the Settings menu.

Others

- FeliCa is a contactless IC card technology developed by Sony Corporation. FeliCa is a registered trademark of Sony Corporation.
- Under the MPEG-4 Visual Patent Portfolio License, customers have licensed permission for the following use of this product to engage in non-profit personal use. Other uses are not permitted.
 - Encoding MPEG-4 standard video (henceforth referred to as MPEG-4 video).
 - Decoding an MPEG-4 video that a customer not engaged in personal commercial activities has encoded.
 - Decoding an MPEG-4 video obtained from a licensed provider. For details on other intended uses, contact MPEG LA, LLC.
- This product is licensed under the MPEG-4 Systems Patent Portfolio License for encoding in compliance with the MPEG-4 Systems Standard. An additional license and payment of royalties are necessary in the following cases.
 - Data stored or replicated in physical media which is paid for on a title by title basis.
 - Data which is paid for on a title by title basis and is transmitted to an end user for permanent storage and/or use. Such additional license may be obtained from MPEG LA, LLC. Contact MPEG LA, LLC for additional details.
- This product is licensed under the AVC patent portfolio license for the personal and noncommercial use of a consumer to (i) encode video in compliance with the AVC standard (henceforth referred to as AVC video) and/or (ii) decode AVC video that was encoded by a consumer engaged in a personal and noncommercial activity and/or was obtained from a video provider licensed to provide AVC video. No license is granted or shall be implied for any other use. Additional information may be obtained from MPEG LA, L.L.C. See <http://www.mpegla.com>
- This product is licensed under the VC-1 Patent Portfolio License for the personal and noncommercial use of a consumer to (i) encode video in compliance with the VC-1 standard (henceforth referred to as VC-1 video) and/or (ii) decode VC-1 video that was encoded by a consumer engaged in a personal and noncommercial activity and/or was obtained from a video provider licensed to provide VC-1 video. No license is granted or shall be implied for any other use. Additional information may be obtained from MPEG LA, L.L.C. See <http://www.mpegla.com>
- Content owners use Microsoft PlayReady™ content access technology to protect their intellectual property, including copyrighted content. This device uses PlayReady technology to access PlayReady-protected content and/or WMDRM-protected content. If the device fails to properly enforce restrictions on content usage, content owners may require Microsoft to revoke the device's ability to consume PlayReady-protected content. Revocation should not affect unprotected content or content protected by other content access technologies. Content owners may require you to upgrade PlayReady to access their content. If you decline an upgrade, you will not be able to access content that requires the upgrade.
- The abbreviations of operating systems (Japanese versions) below are used in this manual.
 - Windows 8.1 stands for Microsoft® Windows® 8.1, Microsoft® Windows® 8.1 Pro and Microsoft® Windows® 8.1 Enterprise.
 - Windows 8 stands for Microsoft® Windows® 8, Microsoft® Windows® 8 Pro and Microsoft® Windows® 8 Enterprise.
 - Windows 7 stands for Microsoft® Windows® 7 (Starter, Home Basic, Home Premium, Professional, Enterprise and Ultimate).
 - Windows Vista stands for Windows Vista® (Home Basic, Home Premium, Business, Enterprise and Ultimate).

- The Bluetooth word mark and logos are owned by the Bluetooth SIG, INC. and any use of such marks by NTT DOCOMO, INC. is under license. Other trademarks and trade names are those of their respective owners.
- Google, Google logo, Android, Google Play, Google Play logo, Google+, Google+ logo, Gmail, Gmail logo, Google Calendar™, Google Calendar logo, Google Maps™, Google Maps logo, Google Chrome™, Google Chrome logo, Google Voice Search™, Google Voice Search logo, YouTube, YouTube logo, Google Drive, Google Drive logo and Google Now are trademarks of Google Inc.

Open source software

- This product includes software based on GNU General Public License (GPL), GNU Lesser General Public License (LGPL) and other licenses. For details on licenses of related software, in the home screen, [⋮] ▶ [Settings] ▶ [About tablet] ▶ [Legal information] ▶ [Open source licenses].
- Source codes of software based on GPL, LGPL and Mozilla Public License (MPL) can be referred to on the following website for free. For details, refer to the following website. <https://sh-dev.sharp.co.jp/android/modules/oss/> (in Japanese only)

Unlocking SIM lock

- The tablet can unlock the SIM lock. Unlock the SIM lock to use non-DOCOMO SIM cards.
- Some services, functions, etc. may be unavailable. DOCOMO shall not guarantee any operation of the tablet.
- For details on the procedure of unlocking SIM lock, refer to the DOCOMO website.

1 Insert another carrier's SIM card

- For details on how to insert/remove the SIM card (☞ P. 14 “docomo nano UIM card”)

2 Turn the power on

3 Enter the SIM unlock code ▶ [Unlock]

Using mobile phone with your manners!

Please be considerate of those around you when using the tablet.

Turn off your tablet in the following places

■ When in an area where use is prohibited

When you are on an airplane or in a hospital, follow the instructions given by the respective airlines or medical facilities. Turn off the tablet in areas where the use of mobile phones is prohibited.

Set Public Mode in the following places

■ While driving

Using the tablet in hand while driving is regarded as a punishable act. However, some cases such as when rescuing sick and injured people or maintaining public safety are exempted.

■ When in public places such as theaters, movie theaters or museums

Using the tablet in public places where you should be quiet results in disturbing others.

Be aware of the place to use a mobile phone and the volume of your voice and ringtone

- Be aware of the volume of your voice when using the tablet in quiet places such as restaurant and hotel lobby.
- Use in places where you do not block a passage in the town.

Be considerate of the privacy of the individuals around you

- Please be considerate of the privacy of individuals around you when taking and sending photos using camera-equipped tablet.

These functions ensure manners in public

The tablet has convenient functions such as setting not to answer a call and setting to mute sound of the tablet.

● Manner mode (☎ P. 66 “Mode settings”)

Mutes sound of the tablet.

※ However, the manner mode cannot mute camera shutter sound.

● Public Mode (Phone OFF) (☎ P. 37 “Network service”)

When a call is received, a message stating that you are in a place that does not allow the use of mobile phone is played and the call is automatically disconnected.

● Phone vibration (☎ P. 65 “Sound/notification”)

Notifies you of incoming call with vibration.

● Answering memo (☎ P. 37 “Voice/Answering memo”)

Records callers' messages when you cannot answer the call.

※ Additionally, optional services such as Voice Mail Service (☎ P. 37 “Network service”) and Call Forwarding Service (☎ P. 37 “Network service”) are available.

Carrying out various procedures, checking subscription, etc. online

- From the tablet **dmenu ▶ お客様サポート (Support) ▶ ドコモオンライン手続き (docomo online procedure) (in Japanese only)**
 - From a PC **My docomo (https://www.nttdocomo.co.jp/mydocomo/) ▶ 住所や契約内容の変更手続きがしたい (Change your address or subscription) (in Japanese only)**
- ※ You may not be able to access some website services due to system maintenance, the content of your subscription, etc.
- ※ “Network security code” or “docomo ID/Password” is required to use “ドコモオンライン手続き” (docomo online procedure).



モバイルリサイクルネットワーク
携帯電話 PHS のリサイクルにご協力。

We collect your unnecessary mobile phones and other devices irrespective of carrier. Bring them to a docomo Shop near you.

※ Intended devices: Mobile phone, PHS, battery pack, charger and desktop holder (irrespective of carrier)