

SHARP SERVICE MANUAL

S9706R8580J//

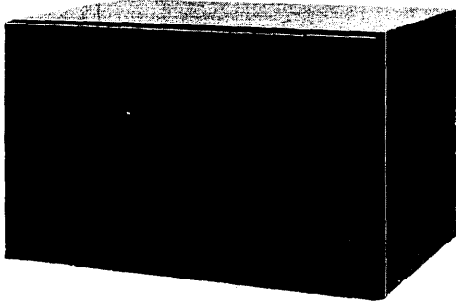

CONVECTION MICROWAVE OVEN

MODEL R-8580

In the interests of user-safety the set should be restored to its original condition and only parts identical to those specified should be used.
(RD16101U)

TABLE OF CONTENTS

	Page
PRECAUTIONS	INSIDE FRONT COVER
FOREWORD	1
THUMB INDEX	1
PRODUCT DESCRIPTION	2
OPERATION	4
SERVICING	11
TOUCH CONTROL PANEL ASSEMBLY	22
COMPONENT REPLACEMENT AND ADJUSTMENT PROCEDURE	30
MICROWAVE MEASUREMENT PROCEDURE	35
PICTORIAL DIAGRAM	36
CONTROL PANEL CIRCUIT	37
PRINTED WIRING BOARD	38
PARTS LIST	39
PACKING AND ACCESSORIES	47

SERVICE MANUAL

SHARP

CONVECTION MICROWAVE OVEN

R-8580

FOREWORD

This Manual has been prepared to provide Sharp Corp. Service Personnel with complete Operation and Service Information for the SHARP CONVECTION MICROWAVE oven, R-8580.

It is recommended that service personnel carefully study the entire text of this manual so they will be qualified to render satisfactory customer service.

Check interlock switches and door seal carefully. Special attention should be given to avoid electrical shock and microwave radiation hazard.

(RD36102U)

CAUTION MICROWAVE RADIATION

Personnel should not be exposed to the microwave energy which may radiate from the magnetron or other microwave generating devices if it is improperly used or connected. All input and output microwave connections, waveguides, flanges and gaskets must be secured. Never operate the device without a microwave energy absorbing load attached. Never look into an open waveguide or antenna while the device is energized.

Note(Parts List) : The parts marked "*" are used in voltage more than 250V.

(RD36202U)

SHARPCORPORATION

OSAKA, JAPAN

(RD37201U)

PRODUCT DESCRIPTION

OPERATION

SERVICING

TOUCH CONTROL PANEL
ASSEMBLY

COMPONENT REPLACEMENT
AND ADJUSTMENT

MICROWAVE
MEASUREMENT

WIRING DIAGRAM

PARTS LIST

PRODUCT DESCRIPTION

SPECIFICATION

ITEM	DESCRIPTION
Power Requirements	240 Volts 50 Hertz Single phase, 3 wire earthed
Power Consumption	1400W (Microwave) 1600W (Convection)
Power Output	700 watts normal of RF microwave energy (2 liter water load) Operating frequency of 2450MHz
Convection Heater Power Output	1500 Watts
Case Dimensions	Width 627mm Height 407mm Depth 500mm
Cooking Cavity Dimensions	Width 395mm Height 253mm Depth 422mm
Control Complement	Touch Control System Clock(1:00 - 12:59) Timer (0 - 99 min. 99sec.) Microwave Power for Variable Cooking Repetition Rate; HIGH Full power throughout the cooking time MED HIGH approx. 70% of Full Power MED approx. 50% of Full Power MED LOW (DEFROST) approx. 30% of Full Power LOW approx. 10% of Full Power HOLD No power throughout the cooking time Convection Temperature Control Range; 40 °C - 250 °C AUTO START COOKING INSTANT COOKING EASY DEFROST COOKING CONVECTION COOKING SENSOR COOKING AUTO MATIC MIX COOKING COMPU COOKING
Set Weight	Approx. 31.0 kg

Auto-Touch™ Control Panel

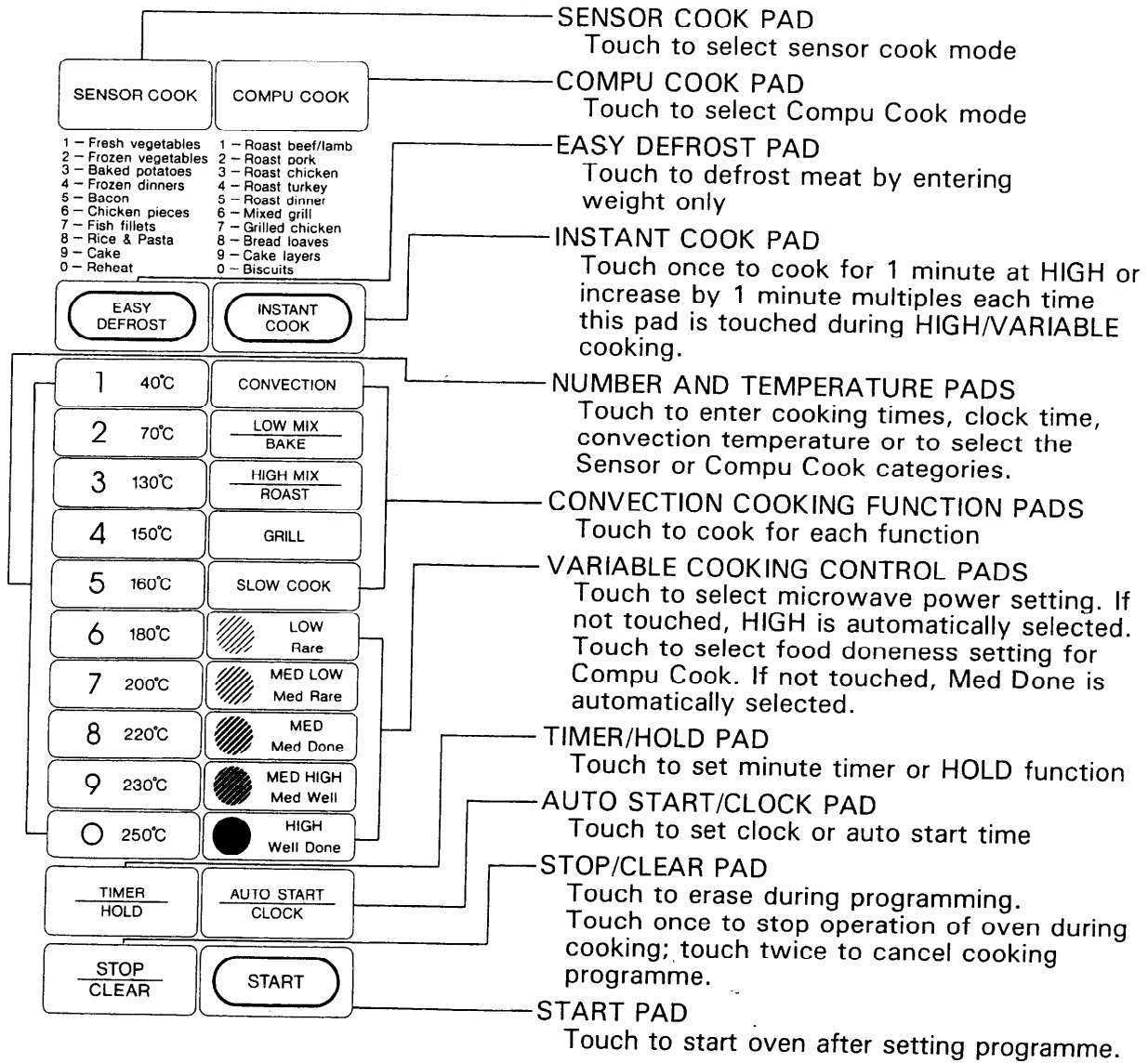

OPERATION

DESCRIPTION OF OPERATING SEQUENCE

The following is a description of component functions during oven operation.

(RD71101U)

OFF CONDITION

Closing the door activates both door interlock switches: upper latch switch, lower latch switch and stop switch. (In this condition, the monitor switch contacts are opened.)

When oven is plugged in, 240 volts A.C. is supplied to the relay unit. (Figure O-1).

1. The display will show flashing "88:88".

To set any program or set the clock; you must first touch the STOP/CLEAR pad. The display will clear, and 1:00 will appear and count up every minute.

Note: When the door is opened, the oven lamp comes on.

2. A signal is input to the control unit, energizing the coil of shut-off relay (RY6).

RY6 contacts close, completing a circuit to the damper motor.

The damper motor now operates moving the damper to the open position, thereby closing the contacts of the damper switch inputs a signal to the control unit.

The coil of relay RY6 is de-energized, opening its contacts, thereby turning off the damper motor.

(RD71207U)

COOKING CONDITION HIGH COOKING

Program desired cooking time and Variable Cooking Control by touching the NUMBER pads and the HIGH pad of the Variable Cooking Control. When the START pad is touched, the following operations occur:

1. The contacts of relays are closed and components connected to the relays are turned on as follows. (For details, refer to Figure O-2)

RELAY	CONNECTED COMPONENTS
RY-1	power transformer
RY-2	oven lamp/turntable motor
RY-3	convection motor
RY-4	convection heater
RY-5	fan motor
RY-6	damper motor

2. 240 volts A.C. is supplied to the primary winding of the power transformer and is converted to about 3.3 volts A.C. output on the filament winding, and approximately 2043 volts A.C. on the high voltage winding.

3. The filament winding voltage heats the magnetron filament and the H.V. winding voltage is sent to a voltage doubler circuit.

4. The microwave energy produced by the magnetron is channeled through the waveguide into the cavity feed-box, and then into the cavity where the food is placed to be cooked.

5. Upon completion of the cooking time, the power transformer, oven lamp, etc. are turned off, and the generation of microwave energy is stopped. The oven will revert to the OFF condition.

6. When the door is opened during a cook cycle, monitor switch, upper latch switch, lower latch switch and stop switch. are activated with the following results. The circuits to the turntable motor, the cooling fan motor, and the high voltage components are deenergized, the oven lamp remains on, and the digital readout displays the time still remaining in the cook cycle when the door was opened.

7. The monitor switch is electrically monitoring the operation of the upper latch switch and is mechanically associated with the door so that it will function in the following sequence.

(1) When the door opens from a closed position, the upper latch switch and lower latch switch open their contacts, and then the monitor switch contacts close.

(2) When the door is closed from the open position, the monitor switch contacts first open, and then the contacts of the upper latch switch and lower latch switch close.

If the common and normal open contacts of upper latch switch fail with their contacts closed when the door is opened, the closing of the monitor switch contacts will form a short circuit through the fuse and upper latch switch, causing the monitor fuse to blow.

MED HIGH, MED, MED LOW (DEFROST). LOW, HOLD COOKING

When Variable Cooking Power is programmed, the 240 volts A.C. is supplied to the power transformer intermittently through the contacts of relay(RY-2) which is operated by the control unit within a 32 second time base. Microwave power operation is as follows:

VARI-MODE	ON TIME	OFF TIME
HIGH (100% power)	32 sec.	0 sec.
MED HIGH (approx. 70% power)	24 sec.	8 sec.
MED (approx. 50% power)	18 sec.	14 sec.
MED LOW (DEFROST) (approx. 30% power)	12 sec.	20 sec.
LOW (approx. 10% power)	6 sec.	26 sec.
HOLD (0% power)	0 sec.	32 sec.

Note: The ON/OFF time ratio does not correspond with the percentage of microwave power, because approx. 2 seconds are needed for heating of the magnetron filament.

(RD71401U)

CONVECTION COOKING CONDITION PREHEATING CONDITION

Program desired convection temperature by touching the CONVECTION pad and the temp. pad.

When the START pad is touched, the following operations occur:

1. The coil of shut-off relays (RY2, RY3 and RY5) are energized, the oven lamp, cooling fan motor, turntable motor and convection motor are turned on.
2. The coil of relay (RY6) is energized by the CPU unit. The damper is moved to the closed position, opening the damper switch contacts. The opening of the damper switch contacts sends a signal to the LSI on the CPU unit de-energizing the relay (RY6) and opening the circuit to the damper motor.
3. The coil of heater relay (RY4) is energized by the CPU unit and the main supply voltage is added to the convection heater.
4. When the oven temperature reaches the selected preheat temperature, the following operations occur:
 - 4-1. The heater relay (RY4) is de-energized by the CPU unit temperature circuit and thermistor, opening the circuit to the convection heater.
 - 4-2. The oven will continue to function for 15 minutes, turning the convection heater on and off, as needed to maintain the selected preheat temperature. The oven will shut-down completely after 15 minutes.

CONVECTION COOKING CONDITION

When the preheat temperature is reached, a beep signal will sound indicating that the holding temperature has been reached in the oven cavity. Open the door and place the food to be cooked in the oven.

Program desired cooking time and convection temperature by touching the NUMBER pad, CONVECTION pad and Temperature pad.

When the START pad is touched, the following operations occur:

1. The numbers of the digital readout start the count down to zero.
2. The oven lamp, turntable motor, cooling fan motor and convection motor are energized.
3. Heater relay (RY4) is energized (if the cavity temperature is lower than the selected temperature) and the main supply voltage is applied to the convection heater to return to the selected cooking temperature.
4. Upon completion of the cooking time, the audible signal will sound, and oven lamp, turntable motor, cooling fan motor and convection motor are de-energized. At the end of the convection cycle, if the cavity air temperature is above 118 °C., the circuit to RY5 will be maintained (by the thermistor circuit) to continue operation of the cooling fan motor until the temperature drops below 118 °C., at which time the relay will be de-energized, turning off the fan motor. Relay RY3 will however, open as soon as the convection cycle has ended, turning off the convection fan motor. This will now cool and allow the damper door to open.

5. At the end of the convection cook cycle, shut-off relay (RY6) is energized turning on the damper motor. The damper is returned to the open position, closing the damper switch contacts which send a signal to the control unit, de-energizing shut-off relay (RY6).

AUTOMATIC MIX COOKING CONDITION

Program desired cooking time and temperature by touching the number pads and the LOW MIX/BAKE or HIGH MIX/ROAST pad

When the START pad is touched, the following operations occur:

1. The numbers of the digital readout start the count down to zero.
2. The shut-off relay (RY2, RY3 and RY5) are energized, turning on the oven lamp, turntable motor, and cooling fan motor.
3. The shut-off relay (RY6) is energized. The damper door is closed from the open position.
4. The heater relay (RY4) is energized, adding the mains supply voltage to the convection heater.
5. Now, the oven is in the convection cooking condition.
6. When the oven temperature reaches the selected temperature, the following operations occur:
 - 6-1. The power supply voltages is added to the convection heater and power transformer alternately.
 - 6-2. The convection heater operates through the heater relay (RY4) contacts and the power transformer operates through the cook relay (RY1) contacts.
 - 6-3. These are operated by the CPU unit to supply alternately within a 32 second time base, convection heat and microwave energy.

The relationship between the convection and microwave power operations are as follows.

Note: The ON and OFF time ratio does not correspond with the percentage of microwave power, because approx. 2 seconds are needed for heating of the magnetron filament.

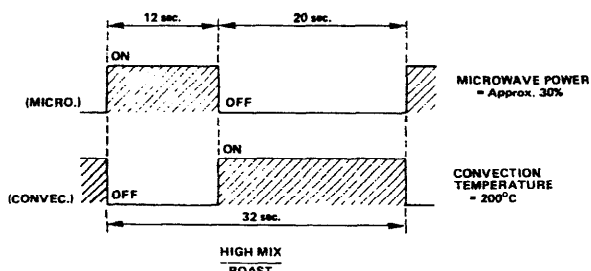
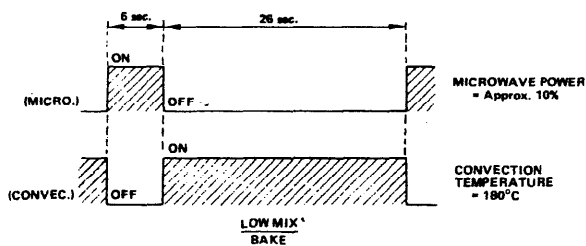

Note: During alternate Microwave/Convection operation, the convection heater is energized only if the cavity temperature drops below the set temperature.

SENSOR COOKING CONDITION

Using the SENSOR COOK function, the foods are cooked without figuring time, power level or quantity. When the oven senses enough steam from the food, it relays the information to its microprocessor which will calculate the remaining cooking time and power level needed for best results.

When the food is cooked, water vapor is developed. The sensor "senses" the vapor and its resistance increases gradually. When the resistance reaches the value set according to the menu, supplementary cooking is started.

The time of supplementary cooking is determined by experiment with each food category and inputted into the LSI.

An example of how sensor works:

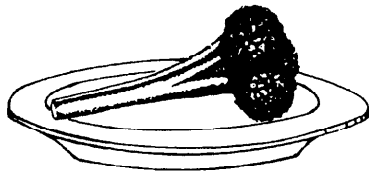

1. Broccoli at room temperature. Vapor is emitted very slowly.

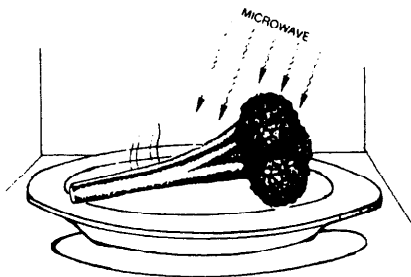

2. Heat broccoli. Moisture and humidity is emitted rapidly. You can smell the aroma as it cooks.

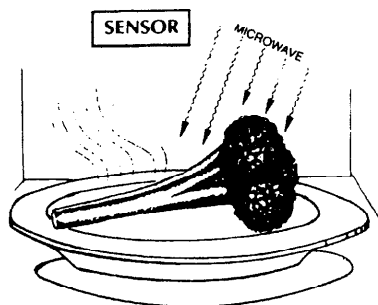

3. Sensor detects moisture and humidity and calculates cooking time and variable power.

Cooking Sequence.

1. Touch SENSOR COOK pad.

NOTE: The oven should not be operated on SENSOR COOK immediately after plugging in the unit. Wait five minutes before cooking on SENSOR COOK.

2. Select desired Sensor setting.
3. Touch START pad.
The coil of shut-off relays (RY2, RY5) are energized, the oven lamp and cooling fan motor are turned on, but the power transformer is not turned on.
4. After about 16 seconds, the cook relay (RY1) is energized. The power transformer is turned on, microwave energy is produced and first stage is started.
The 16 seconds is the cooling time required to remove any vapor from the oven cavity and sensor.
NOTE: During this first stage, do not open the door or touch STOP/CLEAR pad.
5. When the sensor detects the vapor emitted from the food, the display switches over to the remaining cooking time and the timer counts down to zero.
At this time, the door may be opened to stir food, turn it or season, etc.
6. When the timer reaches zero, an audible signal sounds. The shut-off relay and cook relay are de-energized and the power transformer, oven lamp, etc. are turned off.
7. Opening the door or touching the STOP/CLEAR pad, the time of day will reappear on the display and the oven will revert to an OFF condition.

COMPU COOK

COMPU COOK will automatically compute the oven temperature, microwave power and cooking time for baking, roasting and broiling.

Set the desired program by touching the COMPU COOK pad, and number pad.

Enter the weight by touching the Number pads

When the START pad is touched, the following operations occur:

1. The COOK indicator will light and the Convection Fan Symbol will rotate.
2. The cooking time will appear on the display and start counting down to zero.
The cooking time is adjusted automatically according to the weight of the food.
3. The shut-off relays (RY2, RY3, RY4 and RY5) are energized, turning on the oven lamp, turntable motor, cooling fan motor and convection motor. The power supply voltage is added to the convection heater.
4. Now, the oven is in the convection cooking mode.
5. When the oven temperature has reached the programmed convection temperature, the oven goes into the programmed cooking mode.
6. At the end of the COMPU COOK cycle, the damper is returned to the open position and the oven will go to the off condition.
The cooling fan will remain on until the oven has cooled.

EASY DEFROST COOKING

The EASY DEFROST key is a special function key to defrost meats and poultry faster and better.

EASY DEFROST key has 4 defrost stages.

EASY DEFROST automatically defrosts roast beef, etc. When EASY DEFROST is selected and the food weight is entered by using the number pads, the oven will cook according to the special cooking sequence.

AC CORD CONNECTION
 BRN : BROWN
 BLU : BLUE
 G-Y : GREEN AND
 YELLOW STRIPE
 /17 : SECTIONAL AREA
 OF 1.0mm² MIN.

SCHEMATIC
 NOTE: CONDITION
 OF OVEN
 1. DOOR CLOSED
 2. CLOCK APPEARS
 ON DISPLAY

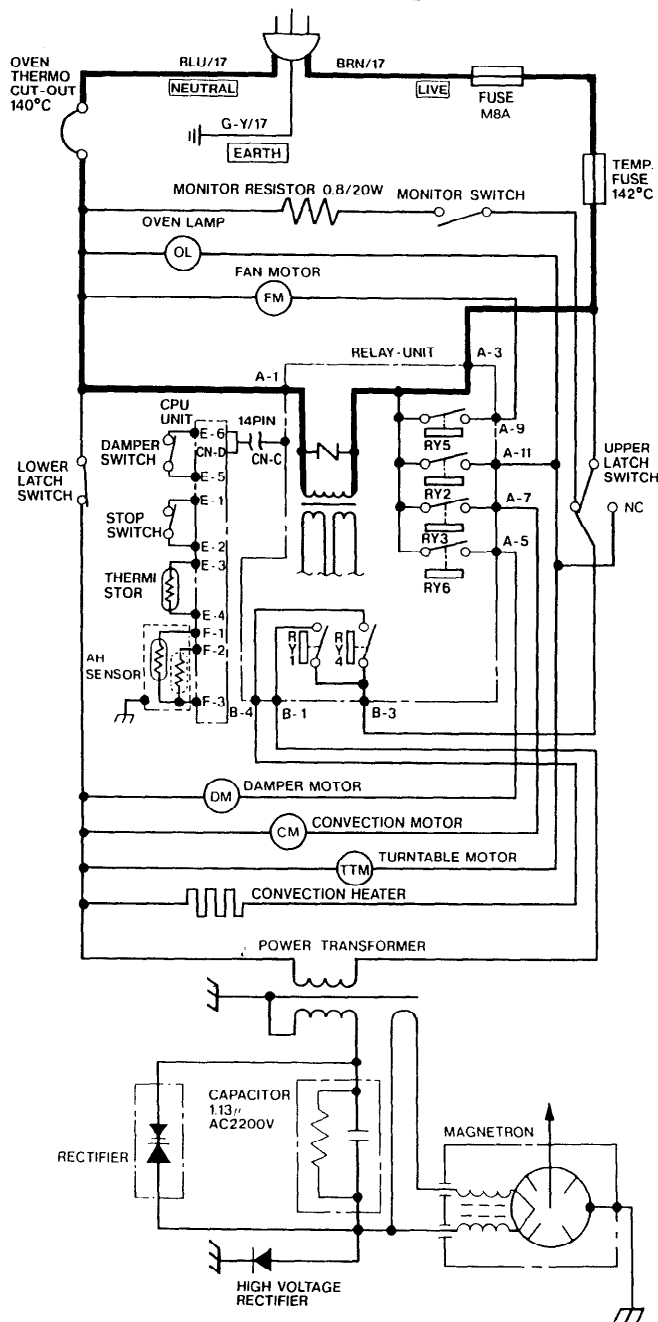

Figure 0-1. Oven Schematic-OFF Condition

AC CORD CONNECTION
 BRN : BROWN
 BLU : BLUE
 G-Y : GREEN AND
 YELLOW STRIPE
 /17 : SECTIONAL AREA
 OF 1.0mm² MIN.

SENSOR COOKING
SCHEMATIC
 NOTE: CONDITION
 OF OVEN
 1. DOOR CLOSED
 2. 'SENSOR COOK'
 PAD TOUCHED
 3. 'START PAD'
 TOUCHED

HIGH COOKING
SCHEMATIC
 NOTE: CONDITION
 OF OVEN
 1. DOOR CLOSED
 2. COOKING TIME
 PROGRAMMED
 3. VARIABLE COOKING
 CONTROL "HIGH"
 4. START PAD TOUCHED

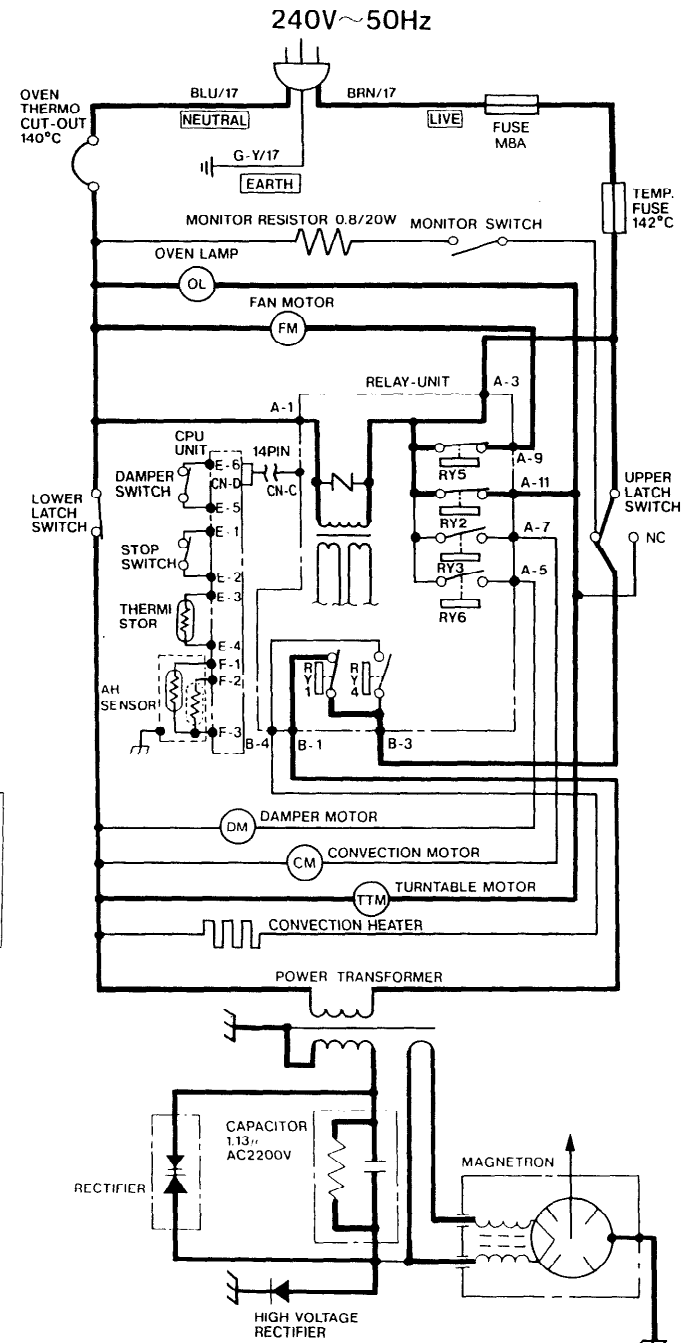

Figure 0-2. Oven Schematic-High and Sensor Cooking Condition

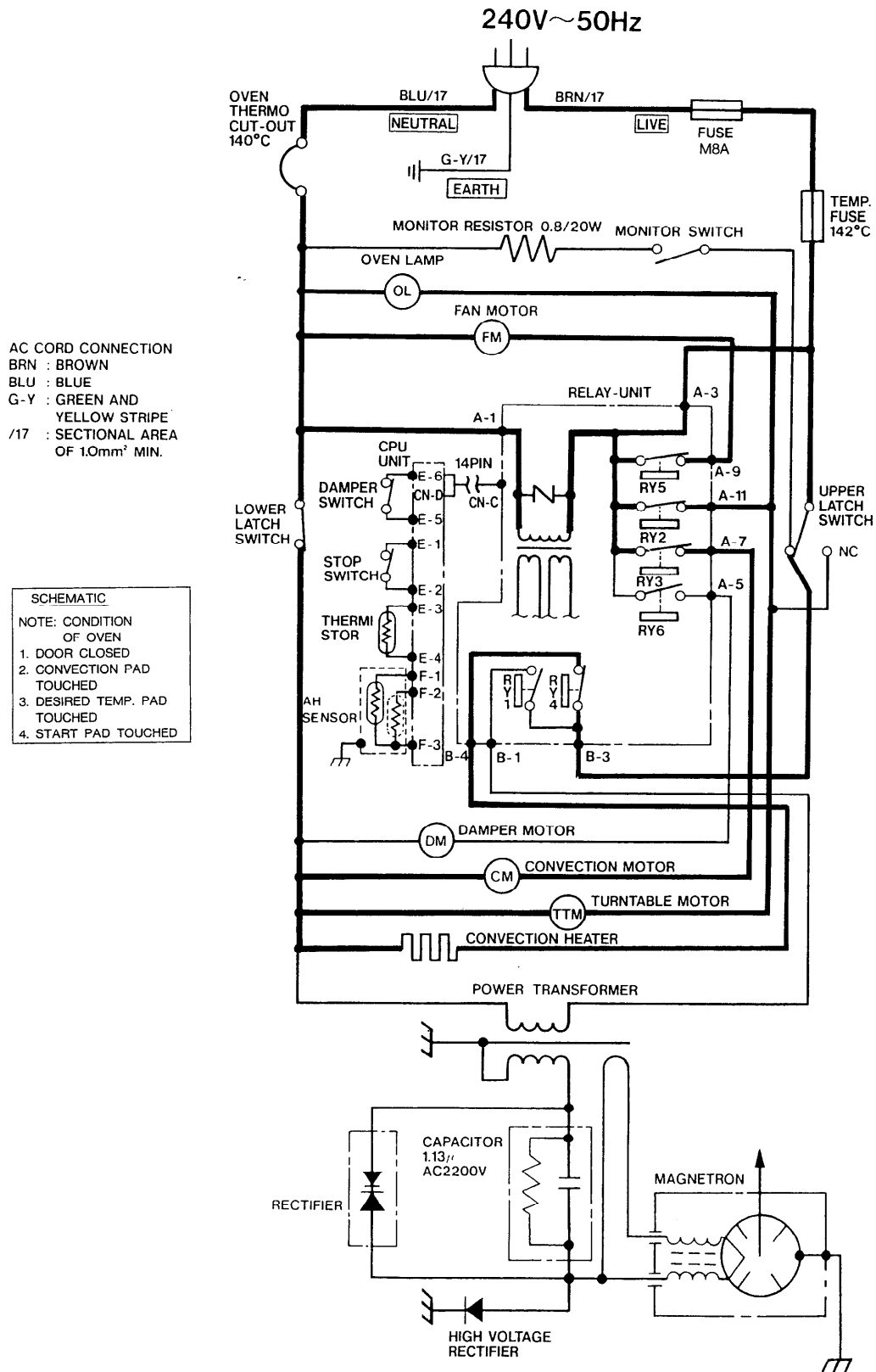

Figure 0-3. Oven Schematic-Convection Cooking Condition

DESCRIPTION AND FUNCTION OF COMPONENTS

THERMISTOR

The thermistor is a negative temperature coefficient type. The temperature in the oven cavity is detected through the resistance of the thermistor, and then the CPU unit causes the heater relay to operate, thus the current to the convection heater is turned ON/OFF.

OVEN THERMAL CUT-OUT

The oven thermal cut-out located on the bottom side of the thermal protection plate is designed to prevent damage to the convection heater unit if an overheated condition develops in the tube due to cooling fan failure, obstructed air ducts, dirty or blocked air intake, etc. Under normal operation, the oven thermal cut-out remains closed. However, when abnormally high temperatures are reached within the heater unit, the oven thermal cut-out will open, causing the oven to shut down.

When the oven has cooled temperature, the oven thermal cut-out closes.

MONITOR SWITCH

The monitor switch is mounted on the upper latch hook. It is activated (the contacts opened) by the upper latch head when the door is closed. The switch is intended to render the oven inoperative by means of blowing the fuse when the contacts of the common and normal open contacts of upper latch switch fail to open when the door is opened.

Functions:

1. When the door is opened, the monitor switch contacts close (to the ON condition) due to their being normally closed. At this time the the common and normal open contacts of upper latch switch are in the OFF condition (contacts open) due to their being normally open contacts switch.
2. As the door goes to a closed position, the monitor switch contacts are first opened and then the common and normal open contacts of upper latch switch close. (On opening the door, each of these switches operate inversely.)
3. If the door is opened during cooking, and the common and normal open contacts of upper latch switch fail to open, the monitor fuse blows simultaneously with closing of the monitor switch contacts.

CAUTION: BEFORE REPLACING A BLOWN FUSE TEST THE UPPER LATCH SWITCH AND MONITOR SWITCH FOR PROPER OPERATION. (REFER TO CHAPTER "TEST PROCEDURE"). AFTER REPLACING FUSE ALSO REPLACE MONITOR SWITCH.

STOP SWITCH

The stop switch is activated by the lower latch head. When the door is opened while the oven is in cook cycle, the stop switch contacts open to de-energize the relay (RY-1, RY-2, RY-3, RY-4, RY-5). Then the cook cycle is stopped.

UPPER AND LOWER LATCH SWITCHES

The lower latch switch is mounted in the lower latch hook and the upper latch switch is mounted in the upper latch hook. They are activated by the latch heads on the door. When the door is opened, the switches interrupt the circuit to all components except CPU unit and relay unit and oven lamp. A cook cycle cannot take place until the door is firmly closed thereby activating both interlock switches.

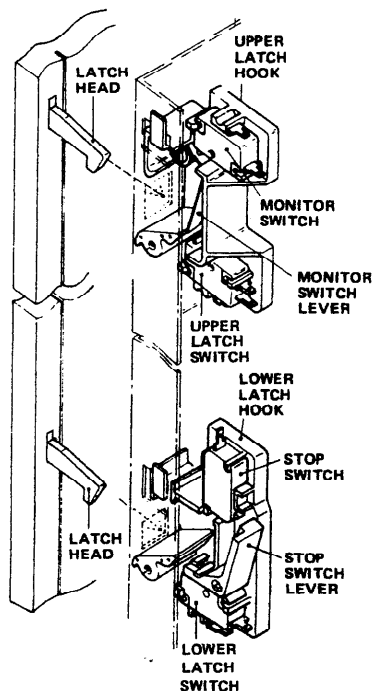

Figure D-1. Upper Latch Switch, Lower Latch Switch, Monitor Switch and Stop Switch

CONVECTION HEATER

The convection heater is located at the left side of the oven cavity. It is intended to heat air driven by the convection fan. The heated air is kept in the oven and force-circulated and reheated by the convection heater.

CONVECTION COOKING SYSTEM

This oven is designed with a hot air heating system where food is not directly heated by the convection heater, but is heated by forced circulation of the hot air produced by the convection heater.

The air heated by the convection heater is circulated through the convection passage provided on the outer casing of the oven cavity by means of the convection fan which is driven by the convection motor. It then enters the inside of the oven through the vent holes provided on the left side of the oven. Next, the hot air heats the food on the turntable and leaves the oven cavity through the vent in the oven cavity left side wall. Without leaving the oven, this hot air is reheated by the convection heater, passes through the convection passage and enters the inside of the oven cavity again, in a continuing cycle.

In this way, the hot air circulates inside the oven cavity to raise its temperature and, at the same time, comes into contact with the food being cooked.

When the temperature inside the oven cavity reaches the selected temperature, the convection heater is de-energized. When the temperature inside the oven cavity drops below the selected temperature, the convection heater is energized again. In this way, the inside of the oven cavity is maintained at approximately the selected temperature.

When the convection time reaches 0, the convection heater is deenergized and the convection fan stops operating and the oven shuts off.

Upon completion of the cooking time, the audible signal will sound, and oven lamp, turntable motor, cooling fan motor and convection motor are de-energized. At the end of the convection cycle, if the cavity air temperature is above 118 °C., the circuit to RY5 will be maintained (by the thermistor circuit) to continue operation of the cooling fan motor until the temperature drops below 118 °C., at which time the relay will be de-energized, turning off the fan motor. Relay RY3 will however, open as soon as the convection cycle has ended, turning off the convection fan motor. This will now cool and allow the damper door to open.

DAMPER OPEN-CLOSE MECHANISM

Usually, the damper is in the open position except during convection cooking.

Damper position is set automatically by damper motor, damper switch, motor cam and damper shaft.

These components are operated by a signal that judges if microwave cooking or convection cooking operation is selected by the CPU unit.

Microwave Cooking:

Damper is in the open position, because a portion of cooling air is channeled through the cavity to remove steam and vapors given off from the heating foods. It is then exhausted at the top of the oven cavity into a condensation compartment.

Convection Cooking:

Damper is in the closed position, so that no hot air will be allowed to leak out the oven cavity.

Damper Operation

1. When power supply cord is plugged in:
 - 1-1. When power supply cord is plugged in, a signal is sensed in the control unit, and operates shut-off relay (RY6).
 - 1-2. Contacts of shut-off relay (RY6) close, the damper motor is energized, opening the damper door.
 - 1-3. When the damper is moved to the open position by the damper cam damper switch is closed (ON position).
 - 1-4. The signal of damper switch is re-sensed in the control unit and shut-off relay (RY6) is turned off.
 - 1-5. The 240 volts A.C. to the damper motor is stopped and the motor turns off.
2. When oven is microwave cooking:
Damper is in the open position.
3. When oven is convection cooking:
 - 3-1. Damper motor is energized by touching the convection, temperature and START pads.
 - 3-2. When damper is in the closed position (damper switch is OFF), its signal is sensed by the control unit, and shut-off relay (RY6) is de-energized.
 - 3-3. The damper is held in the closed position during the convection cooking operation.
 - 3-4. At the end of the convection cooking, shut-off relay (RY6) is energized, and the damper is returned to the open position.

NOTE: If the damper door is not in the proper position, closed during convection or open during microwave, the control unit will stop oven operation after 1 minute.

Cooking Mode	Operation of Damper
Microwave cooking	OPEN
Convection cooking	CLOSE
Sensor cooking	OPEN
Automatic mix cooking	CLOSE
Grill cooking	CLOSE
Slow cooking	CLOSE

SERVICING

TROUBLESHOOTING GUIDE

When troubleshooting the microwave oven, it is helpful to follow the Sequence of Operation in performing the checks. Many of the possible causes of trouble will require that a specific test be performed. These tests are given a procedure letter which will be found in the "Test Procedure" section.

IMPORTANT: If the oven becomes inoperative because of a blown fuse in the monitor switch and upper latch switch circuit, check the monitor switch and upper latch switch before replacing the fuse. If the fuse is replaced, the monitor switch should be replaced at same time.

(RD81102U)

PROBLEM	POSSIBLE CAUSE	TEST PROCEDURE OR CORRECTION
---------	----------------	------------------------------

OFF CONDITION

Home fuse blows when power cord is plugged into wall receptacle.	Shorted wire in power cord or wire harness.	Replace cord or check wiring.
Fuse blows when power cord is plugged into wall receptacle.	Shorted wire in power cord or wire harness.	Replace power cord or check and repair harness.
	Defective monitor switch.	Procedure F.
88:88 do not appear in display when power cord is first plugged into wall outlet.	No power at outlet.	Check home fuse.
	Blown fuse.	Procedure G.
	Blown magnetron temp. fuse.	Procedure H.
	Defective thermal cut-out.	Procedure I.
	Open wire in power cord, wiring harness, or wiring between control panel assembly units.	Replace or repair wiring.
	Defective CPU unit.	Procedure O.
Display does not operate properly when STOP/CLEAR key is touched. (Buzzer should sound and time of day should appear in display.)	Defective relay unit.	Procedure N.
	Defective key unit.	Procedure P.
	Defective CPU unit.	Procedure O.
	Defective relay unit.	Procedure N.
Oven lamp does not light with door opened.	Defective stop switch.	Procedure E.
	No power in home.	Check wall outlet.
	Open wire in power cord or wire harness.	Replace same or repair wiring.
	Defective oven lamp.	Replace.
	Defective upper latch switch.	Procedure E.
	Blow fuse.	Procedure G.
	Defective thermal cut-out.	Procedure I.
	Defective magnetron temp. fuse.	Procedure H.
Open or loose wire connection to the above components.	Check wiring.	

PROBLEM	POSSIBLE CAUSE	TEST PROCEDURE OR CORRECTION
---------	----------------	------------------------------

COOKING CONDITION

Oven lamp does not light in cook cycle. (Does light when door is opened)	Defective shut-off relay (RY2) on relay unit.	Procedure N.
	Defective CPU unit.	Procedure O.
Oven lamp does not light at all.	Burned out bulb.	Replace
	Open wiring of oven lamp.	Check and repair wiring
Oven lamp lights, but turntable motor does not operate.	Open or loose wiring to turntable motor.	Check and repair wiring
	Defective turntable motor.	Replace
Turntable motor operates normally but cooling fan motor does not operate	Defective cooling fan motor.	Replace.
	Defective shut-off relay (RY5) on relay unit.	Procedure N.
	Open or loose wiring to fan motor	Check and repair wiring

MICROWAVE

Oven does not go into a cook cycle when START pad is touched.	Upper latch switch and/or lower latch switch defective or out adjustment.	Procedure E.
	Defective cook relay (RY1) on relay unit.	Procedure N.
	Defective CPU unit.	Procedure O.
	Defective key unit.	Procedure P.
	Open or loose wiring to above components.	Check and repair wiring
Oven seems to be operating but little or no heat is produced in oven load.(Food incompletely cooked or not cooked at all at end of cook cycle.)	Defective magnetron.	Procedure A.
	Defective cook relay (RY1) on relay unit.	Procedure N.
	Defective power transformer.	Procedure B.
	Defective high voltage rectifier.	Procedure C.
	Defective high voltage capacitor.	Procedure D.
	Defective CPU unit.	Procedure O.
Open or loose wiring to above components.	Check and repair wiring	
Oven goes into a cook cycle but extremely uneven heating is produced in oven load(food).	Turntable motor does not operate.	Replace turntable motor or check and repair wiring.
Oven does not cook properly when programed for MEDIUM etc. cooking powers. (Operates properly on HIGH)	Defective CPU unit.	Procedure O.
	Defective key unit.	Procedure P.
	Open or loose wiring to above components.	Check and repair wiring
Oven does not cook properly when programed in EASY DEFROST cooking mode.	Defective EASY DEFROST function.	Refer to EASY DEFROST section in operation manual and check CPU unit.

PROBLEM	POSSIBLE CAUSE	TEST PROCEDURE OR CORRECTION
---------	----------------	------------------------------

CONVECTION

CONV indicator light but oven does not go into a cook cycle when START pad is touched.	Defective heater relay(RY4) on relay unit.	Procedure N.
	Defective key unit.	Procedure P.
	Defective thermistor.	procedure K.
	Open wiring in circuit to above components.	Check and repair wiring.
CONV indicator lights, but heating element does not heat.	Defective convection heater.	Procedure J.
	Defective heater relay(RY4) on relay unit.	Procedure N.
	Defective CPU unit.	Procedure O.
	Open or loose wire connection to the above components.	Check and repair wiring.
Temperature in the oven cavity is lower or higher than preset.	Defective convection heater.	Procedure J.
	Defective CPU unit.	Procedure O.
	Defective convection motor.	Replace motor.
	Defective thermistor.	Procedure K.
	Defective cooling fan motor.	Replace fan motor.
	Defective dumper motor.	Procedure L.
	Defective drive mechanism of convection fan.	Check.
Lower than preset temperature.	Low power supply voltage.	Check voltage.
Cooling fan motor, turntable motor and oven lamp run intermitantly or all the time.	Thermistor shorted.	Procedure K.
Convection cycle runs 3 minutes then shuts down.	Thermistor open.	Procedure K.

SENSOR

Oven is in the sensor cooking condition but AH sensor does not end stage 1 or does not stop cooking cycle or the oven stops soon.	AH sensor open and/or short.	Procedure Q.
	Defective CPU unit.	Procedure O.
	Open or loose wire connection to the above components.	Check and repair wiring.
	AH sensor assembly and/or steam duct are not re-installed correctly.	Check and repair them.

TEST PROCEDURES

PROCEDURE
LETTER

COMPONENT TEST

A

MAGNETRON ASSEMBLY TEST

DISCHARGE THE HIGH VOLTAGE CAPACITOR BEFORE TOUCHING ANY OVEN COMPONENTS OR WIRING.

To test for an open filament, isolate the magnetron from the high voltage circuit. A continuity check across the magnetron filament leads should indicate less than 1 ohm.

To test for a shorted magnetron, connect the ohmmeter leads between the magnetron filament leads and chassis ground. This test should indicate an infinite resistance. If there is little or no resistance, the magnetron is grounded and must be replaced.

Power output of the magnetron can be measured by performing a water temperature rise test. This test should only be used if above tests do not indicate a faulty magnetron and there is no defect in the following components or wiring: high voltage rectifier, rectifier, high voltage capacitor, and power transformer.

MICROWAVE OUTPUT POWER

Microwave output power from the magnetron can be measured by way of substitution, i.e. it can be measured by using water load how much it can be absorbed by the water load. To measure the microwave output power in the microwave oven, the relation of calorie and watt is used. When P(W) heating works for t(second), approximately $P \times t / 4.2$ calorie is generated. On the other hand, if the temperature of the water with V(ml) rises ΔT (°C) during this microwave heating period, the calorie of the water is $V \times \Delta T$.

The formula is as follows;

$$P \times t / 4.2 = V \times \Delta T$$

$$P (W) = 4.2 \times V \times \Delta T / t$$

Our condition for the water load is as follows:

$$\text{Water load ... 2000 ml, Heating time ...120 seconds}$$

$$P = 70 \times \Delta T$$

Measuring method;

1. Put the water load of two (2) litres on the center of the oven shelf. The water load should be arranged in two (2) Pyrex beakers, the size of which is one (1) litre, and be placed at right and left, side by side, on the oven shelf.
2. Measure the temperature of water before heating and also after heating during 120 seconds by microwave, and calculate the temperature rise. The temperature rise should be the average of temperature differences measured in each beaker.
3. The output power should be calculated as follows. In case the measuring result is not satisfactory, execute the measurement several times and judge the result from the synthetic point of view. Microwave output power should be within $\pm 15\%$ of the nominal one.

Calculation of output power;

Microwave output power ... $P (W) = 70 \times \Delta T$ (°C)

$$\Delta T = (\Delta TL + \Delta TR) / 2 : \text{average temperature rise}$$

$$\Delta TL = (TL2 - TL1), \quad \Delta TR = (TR2 - TR1)$$

TL2 : water temperature after heating in left beaker

TL1 : water temperature before heating in left beaker

TR2 : water temperature after heating in right beaker

TR1 : water temperature before heating in right beaker

Measuring condition;

As the microwave output is affected by several conditions, the measurement should be made carefully with following attentions.

1. Initial temperature of salt water should be 10 ± 1 °C. Well and quickly stir the water and the temperature measurement should be done immediately after heating.
2. The graduation of thermometer should be scaled by 0.1 °C at minimum and an accurate mercury thermometer is recommended.

TEST PROCEDURES (CONT'D)

PROCEDURE
LETTER

COMPONENT TEST

3. Water container should be one (1) litre beaker made of Pyrex glass and its diameter approximately 12 cm.
4. Room temperature should be around 20 °C.
5. Power supply voltage should be specification voltage.

B

POWER TRANSFORMER TEST

DISCHARGE THE HIGH VOLTAGE CAPACITOR BEFORE TOUCHING ANY OVEN COMPONENTS OR WIRING.

Disconnect the primary input terminals and measure the resistance of the transformer with an ohmmeter. Check for continuity of the coils with an ohmmeter. On the R x 1 scale, the resistance of the primary coil should be approx. 1.6 ohm and the resistance of the high voltage coil should be approximately 74 ohms; the resistance of the filament coil should be less than 1 ohm.

(HIGH VOLTAGES ARE PRESENT TO HIGH VOLTAGE TERMINAL, SO DO NOT ATTEMPT TO MEASURE THE FILAMENT AND HIGH VOLTAGE.)

C

HIGH VOLTAGE RECTIFIER AND RECTIFIER TEST

DISCHARGE THE HIGH VOLTAGE CAPACITOR BEFORE TOUCHING ANY OVEN COMPONENTS OR WIRING.

HIGH VOLTAGE RECTIFIER TEST

Isolate the high voltage rectifier from the circuit. Using the highest ohm scale of the meter, read the resistance across the terminals and observe, reverse the leads to the high voltage rectifier terminals and observe meter reading. If a short is indicated in both directions, or if an infinite resistance is read in both directions, the high voltage rectifier is probably defective and should be replaced.

RECTIFIER TEST

Isolate the rectifier from the circuit. Using the highest ohm scale of the meter, read the resistance across the terminals, reverse the leads to the rectifier terminals and observe meter reading. If an infinite resistance is read in both directions, the rectifier is good. If a short is indicated in either direction, the one is probably defective and should be replaced.

D

HIGH VOLTAGE CAPACITOR TEST

DISCHARGE THE HIGH VOLTAGE CAPACITOR BEFORE TOUCHING ANY OVEN COMPONENTS OR WIRING.

If the capacitor is open, no high voltage will be available to the magnetron. Disconnect input leads and check for short or open, between the terminals using an ohmmeter. Checking with a high ohm scale, if the high voltage capacitor is normal, the meter will indicate continuity for a short time and should indicate approximately 10M Ω once the capacitor is charged. If the above is not the case, check the capacitor with an ohmmeter to see if it is shorted between the terminals. If it is shorted, replace the capacitor.

(RD82603U)

E

SWITCH TEST

Isolate the switch and check the contacts by using an ohmmeter using the following table. If improper operation is indicated, make the necessary switch adjustment or replacement.

Table: Switch Connection

Connection Operation	Common Terminal-Normally Open Terminal (COM) (NO)	Common Terminal-Normally Close Terminal (COM) (NC)
Plunger released	Open circuit	Close circuit
Plunger pushed	Closed circuit	Open circuit

(RD82701U)

TEST PROCEDURES (CONT'D)

PROCEDURE LETTER

COMPONENT TEST

F

MONITOR SWITCH TEST

Before performing this test, disconnect oven from power supply and make sure that the upper latch switch is operating properly referring to the above Switch Test Procedure. Disconnect the wire lead from the monitor switch (NC) terminal. Check the monitor switch operation by using the ohmmeter as follows. When the door is open, the meter should indicate a closed circuit. When the monitor switch actuator is pushed by a screw driver through the upper latch hole on the front plate of the oven cavity with the door opened (in this condition the plunger of the monitor switch is pushed in), the meter should indicate an open circuit. If improper operation is indicated, replace the defective switch.

After testing the monitor switch, re-connect the wire lead to the monitor switch (NC) terminal.

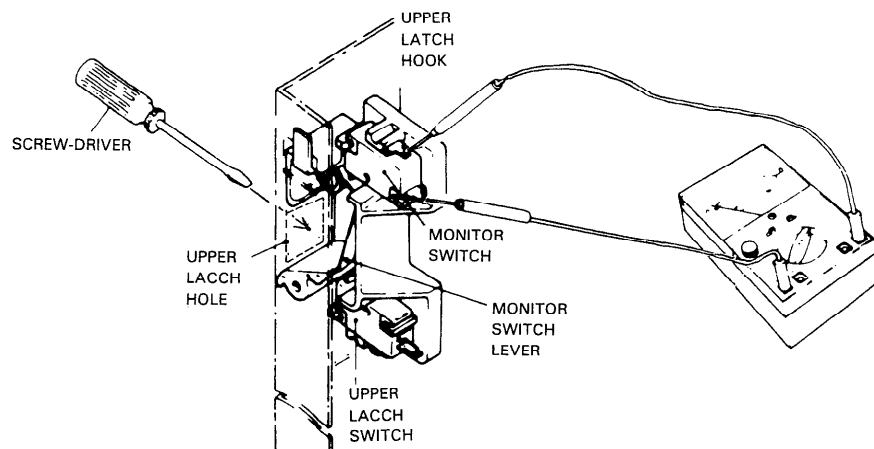

G

BLOWN FUSE

If the fuse in the upper latch-monitor switch circuit is blown when the door is opened, check the upper latch switch and monitor switch according to the Test Procedure for those switches, before replacing the blown fuse.

If the fuse is replaced, the monitor switch should be replaced at the same time.

If the fuse is blown by improper switch operation, adjust or replace the defective switch, fuse at the same time.

Replace the fuse and monitor switch, even if the switches operate normally
CAUTION; REPLACEMENT FUSE MUST BE THE LISTED FUSE IN PARTS LIST.

H

TEMP. FUSE TEST

A continuity check across the temp. fuse terminals should indicate a closed circuit.

If the temperature of the magnetron reaches 142 °C, the temp. fuse opens. If the temp. fuse has opened, replace the fuse. An open temp. fuse indicates overheating of the magnetron assembly. Check for restricted air flow to the magnetron through the opening in the chassis, especially the cooling duct and colling fan.

I

THERMAL CUT-OUT

A continuity check across the thermal cut-out terminals should indicate a closed circuit unless the temperature of the thermal cut-out reaches approximately 140 °C. The thermal cut-out resets automatically at approximately 115 °C.

If the thermal cut-out has opened under the normal condition, replace the same one in parts list. An open thermal cut-out indicates overheating of the heater unit. Check for restricted air flow to the heater unit through the vent holes of the oven cavity, especially the heater duct and convection fan.

TEST PROCEDURES (CONT'D)

PROCEDURE
LETTER

COMPONENT TEST

J

CONVECTION HEATER TEST

Make sure the convection heater is fully cooled and test as follows;

- a. Disconnect wire leads and measure the resistance with an ohmmeter. On the R x 1 scale, the resistance between the convection heater terminals should be approximately 38 ohms.
- b. Disconnect wire leads and measure the insulation resistance with 500V - 100M Ω insulation resistance meter.
The insulation resistance between convection heater terminal and cavity should be more than 0.5M Ω .

K

THERMISTOR TEST

Disconnect connector-E from the control unit. Measure the resistance of the thermistor with an ohmmeter. Connect the ohmmeter leads to Pin No's E-3 and E-4.

Room Temp.	Resistance
20 °C - 30 °C	Approx. 350 Ω - 155 Ω

If the meter does not indicate above resistance, replace the thermistor.

L

DAMPER MOTOR TEST

When the power cord is plugged into the wall receptacle, and 240 volts A.C. is supplied to the damper motor the motor operates until the damper is opened and the damper switch closes. Then the damper motor stops operation.

If the damper motor does not operate, check for input voltage by A.C. volt-meter at the motor.

1. Disconnect the power cord from the wall receptacle.
2. Disconnect the wire leads of motor and connect the meter leads to the wire leads of main wire harness.
3. Reconnect the power cord into the wall receptacle.

If 240 volts A.C. is indicated at the wire leads, replace the motor.

Not indicated, check the wire harness and the relay unit.

(RD82E01U)

M

DAMPER SWITCH TEST

Disconnect the wire leads from the switch terminals and connect ohmmeter leads to the common (COM) and normally open (NO) terminals of the switch.

1. When switch actuator is pushed by the damper motor cam, the meter should indicate a closed circuit.
2. When the power cord is plugged into the wall receptacle, the damper motor operates and damper cam starts to rotate.

The switch actuator is released the meter should indicate an open circuit.

If improper operation is indicated, replace the damper switch.

(RD82702U)

TEST PROCEDURES (CONT'D)

PROCEDURE
LETTER

COMPONENT TEST

N

RELAY UNIT TEST

The relay unit consists of circuits including the shut-off relays, buzzer, transformer, etc.

Plug power cord into wall receptacle "88:88" will be flashing in the display.

Remove the outer case and check voltage between Pin Nos. 1 and 3 of the 6-pin connector (A) on the relay unit with an A.C. voltmeter.

The meter should indicate 240 volts, if not check oven circuit.

Shut-off , Cook and Heater Relay Test

These relays are operated by D.C. voltage.

Check voltage at the relay coil with a D.C. voltmeter during the microwave or convection cooking operation.

DC. voltage indicatedDefective relay.

DC. voltage not indicatedCheck diode which is connected to the relay coil. If diode is good, control unit is defective.

RELAY SYMBOL	OPERATIONAL VOLTAGE	CONNECTED COMPONENTS
RY1 (COOK)	Approx. 14 V.D.C.	Power transformer
RY2	Approx. 14 V.D.C.	Oven lamp/Turntable motor
RY3	Approx. 14 V.D.C.	Convection motor
RY4 (HEATER)	Approx. 14 V.D.C.	Heating element
RY5	Approx. 14 V.D.C.	Cooling fan motor
RY6	Approx. 14 V.D.C.	Damper motor

(RD82R02U)

TEST PROCEDURES (CONT'D)

PROCEDURE LETTER

COMPONENT TEST

O

TOUCH CONTROL PANEL ASSEMBLY TEST

The touch control panel consists of circuits including semiconductors such as LSI, ICs, etc. Therefore, unlike conventional microwave ovens, proper maintenance cannot be performed with only a voltmeter and ohmmeter. In this service manual, the touch control panel assembly is divided into three units Control Unit, Key Unit and Relay Unit and troubleshooting by unit replacement is described according to the symptoms indicated.

1. Key Unit.

The following symptoms indicate a defective key unit. Replace the key unit.

- a) When touching the pads, a certain pad produces no signal at all.
- b) When touching a number pad, two figures or more are displayed.
- c) When touching the pads, sometimes a pad produces no signal.

2. Control Unit

The following symptoms indicate a defective control unit. Replace the control unit.

2-1 In connection with pads.

- a) When touching the pads, a certain group of pads do not produce a signal.
- b) When touching the pads, no pads produce a signal.

2-2 In connection with indicators

- a) At a certain digit, all or some segments do not light up.
- b) At a certain digit, brightness is low.
- c) Only one indicator does not light up.
- d) The corresponding segments of all digits do not light up; or they continue to light up.
- e) Wrong figure appears.
- f) A certain group of indicators do not light up.
- g) The figure of all digits flicker.

2-3 Other possible troubles caused by defective control unit.

- a) Buzzer does not sound or continues to sound.
- b) Clock does not operate properly.
- c) Cooking is not possible.
- d) Proper temperature measurement is not obtained.

Note: When defective components, the Control Unit, Key Unit or Relay Unit are replaced, the defective part or parts must be properly packed for return in the shipping carton, with its cushion material, in which the new replacement part was shipped to you.

(RD82S01U)

P

KEY UNIT TEST

If the indicator does not respond to touching a key Pad use the following matrix and place a jumper wire between the proper pin connections making momentary contact with the cable connector disconnected from the control unit.

If the indicator responds and oven goes into operation, the key unit was faulty.

If there is no response, replace the control unit.

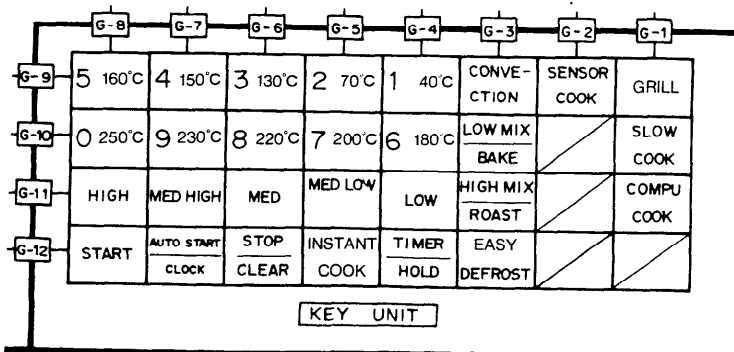

TEST PROCEDURES (CONT'D)

PROCEDURE
LETTER

COMPONENT TEST

Q

AH SENSOR TEST**Checking the initial sensor cooking condition**

- (1) The oven should be plugged in at least five minutes before sensor cooking.
- (2) Room temperature should not exceed 35 °C.
- (3) The unit should not be installed in any area where heat and steam are generated. The unit should not be installed, for example, next to a conventional surface unit. Refer to the "INSTALLATION Instruction".
- (4) Exhaust vents are provided on the back of the unit for proper cooling and air flow in the cavity. To permit adequate ventilation, be sure to install so as not to block these vents. There should be some space for air circulation.
- (5) Be sure the exterior of the cooking container and the interior of the oven are dry. Wipe off any moisture with a dry cloth or paper towel.
- (6) The Sensor works with food at normal storage temperature. For example, chicken pieces would be at refrigerator temperature and canned soup at room temperature.
- (7) Avoid using aerosol sprays or cleaning solvents near the oven while using Sensor settings. The sensor will detect the vapor given off by the spray and turn off before food is properly cooked.
- (8) After 30 minutes if the sensor has not detected the vapor of the food, ERROR will appear and the oven will shut off.

Water load cooking test

Make sure the oven has been plugged in at least five minutes before checking sensor cook operation. The cabinet should be installed and screws tightened.

- (1) Fill approximately 200 milliliters (7.2 oz) of tap water in a 1000 milliliter measuring cup.
- (2) Place the container on the center of tray in the oven cavity.
- (3) Close the door.
- (4) Touch SENSOR COOK pad and number pad 1. Now, the oven is in the sensor cooking condition and SC-1 will appear in the display.
- (5) Touch Start pad. The oven will operate for the first 16 seconds, without generating microwave energy.

When the AH sensor is defective (open or short), ERROR will appear in the display after 16 seconds cooling time.

If ERROR appears check sensor wire connections and/or AH sensor.

NOTE: ERROR will appear if the door is opened or STOP/CLEAR pad is touched during first stage of sensor cooking.

- (6) After approximately 16 seconds, microwave energy is produced, oven should turn off when water is boiling (bubbling).

If the oven does not turn off, replace the AH sensor or check the control unit, refer to explanation below:

TESTING METHOD FOR AH SENSOR AND/OR CONTROL UNIT

To determine if the sensor is defective, the simplest method is to replace it with a new replacement sensor.

- (1) Disconnect oven from power supply and remove outer case.
- (2) Discharge the high voltage capacitor.
- (3) Remove the AH sensor.
- (4) Install the new AH sensor.
- (5) Re-install the outer case.
- (6) Reconnect the oven to the power supply and check the sensor cook operation proceed as follows:
 - 6-1. Touch SENSOR COOK pad and number 0 pad.
 - 6-2. Touch Start pad. The control panel is in automatic Sensor operation.
 - 6-3. The oven will turn off automatically when the water is boiling (bubbling).

If new sensor does not operate properly, the problem is with the control unit.

TEST PROCEDURES (CONT'D)

PROCEDURE
LETTER

COMPONENT TEST

CHECKING CONTROL UNIT

- (1) Disconnect oven from power supply and remove outer case.
- (2) Discharge the high voltage capacitor.
- (3) Disconnect the wire leads from the cook relay.
- (4) Disconnect the sensor connector that is mounted to lower position of control panel.
- (5) Then connect the dummy resistor circuit (see fig.) to the sensor connector of control panel.
- (6) Reconnect the oven to the power supply and check the sensor cook operation proceed as follows:
 - 6-1. Touch SENSOR COOK pad and number 0 pad.
 - 6-2. The control panel is in the sensor cooking operation.
 - 6-3. After approximately 20 seconds, push plunger of select switch.
This condition is same as judgement by AH sensor.
 - 6-4. After approximately 3 seconds, cooking operation turns off, an audible signal will sound, and the display will then revert to the time of day.

If the above is not the case, the control unit is probably defective.
If the above is proper, the AH sensor is probably defective.

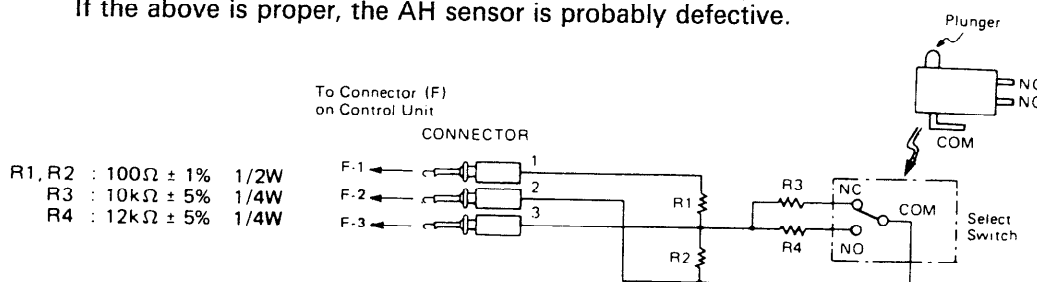

Sensor Dummy Resistor Circuit

R

PROCEDURES TO BE TAKEN WHEN THE FOIL PATTERN ON THE PRINTED WIRING BOARD(PWB) IS OPEN.

To protect the electronic circuits, this model is provided with a fine foil pattern added to the primary on the PWB, and this fine pattern service as a substitute coil. If the foil pattern is open, follow the troubleshooting guide given below for repair.

Problem: POWER ON, indicator does not light up.

STEPS	OCCURANCE	CAUSE OR CORRECTION
1	The rated voltage is not applied to POWER terminal of CPU connector (CN-A)	Check supply voltage and oven main unit.
2	The rated voltage is applied to primary side of power transformer.	Power transformer or secondary circuit defective. Check and repair.
3	Only pattern at "a" is broken.	*Insert jumper wire 1 and solder.
4	Pattern at "a" and "b" are broken.	*Insert the coil RCILF2003YAZZ between "c" and "d".

NOTE:* At the time of these repairs, make visual inspection of the varistor for burning damage and examine the transformer with tester for the presence of layer short-circuit (check primary coil resistance).
If any abnormal condition is detected, replace the defective parts.

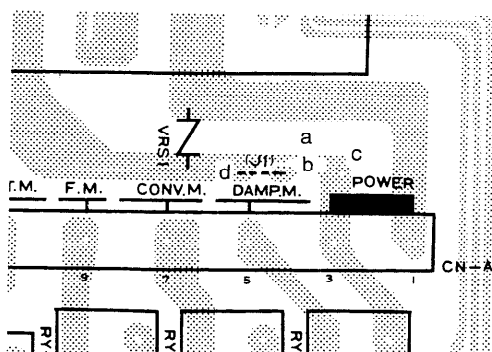

(RD82X04U)

TOUCH CONTROL PANEL ASSEMBLY

OUTLINE OF TOUCH CONTROL PANEL

The touch control section consists of the following units as shown in the touch control panel circuit.

- (1) Relay Unit
- (2) Key Unit
- (3) Control Unit

The principal functions of these units and the signals communicated among them are explained below.

(RD911A4U)

Relay Unit

Relay unit consists of six relays (RY1-RY6), power source circuit and buzzer circuit.

(RD914B1U)

Key Unit

The key unit is composed of a matrix, signals generated in the LSI are sent to the key unit through E7, E8, E11-E13 and E15-E17.

When a key pad is touched, a signal is completed through the key unit and passed back to the LSI through AN4-AN7 to perform the function that was requested.

(RD913A1U)

Control Unit

Control unit consists of LSI, power source circuit, synchronizing signal circuit, ACL circuit, buzzer circuit, temperature measurement circuit, absolute humidity sensor circuit and indicator circuit.

(RD915B1U)

1) LSI

This LSI controls the temperature measurement signal, AH sensor signal, key strobe signal, relay driving signal for oven function and indicator signal.

(RD916A1U)

2) Power Source Circuit

This circuit generates voltages necessary in the control unit.

Symbol	Voltage	Application
VC	-5V	LSI (IC1), ACL circuit and temperature measurement circuit
VA	-16V	Buzzer circuit and IC2
VS	+0.5V	IC2
VP	-34V	Fluorescent display tube : Grid and anode voltage
VF1	-25V	Filament of fluorescent display tube
VF2	-28V	VF1 - VF2 voltage

(RD917A1U)

3) Synchronizing Signal Circuit

The power source synchronizing signal is available in order to compose a basic standard time in the clock circuit.

It accompanies a very small error because it works on commercial frequency.

(RD918A1U)

4) ACL Circuit

A circuit to generate a signal which resets the LSI to the initial state when power is supplied.

(RD919A1U)

5) Buzzer Circuit

The buzzer is responsive to signals from the LSI to emit noticing sounds (key touch sound and completion sound).

(RD91AA1U)

6) Temperature Measurement Circuit: Oven temp.

The temperature in the oven cavity is sensed by the thermistor.

The variation of resistance according to sensed temperature is detected by the temperature measurement circuit and the result applied to LSI.

The result of detecting is given to LSI controlling the relay and display.

(RD91FB1U)

7) Absolute Humidity Sensor Circuit

The circuit detects absolute humidity of a food which is under cooking, to allow its automatic cooking.

(RD91GA1U)

8) Door Sensing Switch

A switch to "tell" the LSI if the door is open or closed.

(RD91BA2U)

9) Relay Circuit

To drive the magnetron, heating element, fan motor, convection motor, damper motor, turntable motor and light the oven lamp.

(RD91CB1U)

10) Indicator Circuit

Indicator element is a Fluorescent Display.

Basically, a Fluorescent Display is triode having a cathode, a grid and an anode. Usually, the cathode of a Fluorescent Display is directly heated and the filament serves as cathode.

The Fluorescent Display 7-digits, 15-segments are used for displaying figures.

(RD91DA1U)

DESCRIPTION OF LSI

LSI(IZA096DR)

The I/O signal of the LSI(IZA096DR) is detailed in the following table.

(RD93101U)

PIN NO.	1-6	SIGNAL	E0-E5	I/O	OUT
---------	-----	--------	-------	-----	-----

Digit selection signal.

Refer to the touch control panel circuit about the relation between signals and digits.

Normally, one pulse is output in every synchronized signal period, and input to the grid of the fluorescent display.
(RD938A1U)

PIN NO.	7	SIGNAL	E6	I/O	OUT
---------	---	--------	----	-----	-----

Segment data signals.

Refer to the touch control panel circuit for the relationship between signals and indicators.

Normally, one pulse is output in every synchronized signal period, and input to the anode of the fluorescent display.
(RD939A1U)

PIN NO.	8	SIGNAL	E7	I/O	OUT
---------	---	--------	----	-----	-----

Segment data signal.

Signal similar to E6.

Key strobe signal.

Signal applied to touch-key section.

A pulse signal is input to AN4-AN7 terminal while one of G-1 line keys on key matrix is touched.

(RD939A3U)

PIN NO.	9	SIGNAL	E8	I/O	OUT
---------	---	--------	----	-----	-----

Segment data signal.

Signal similar to E6.

Key strobe signal.

Signal applied to touch-key section.

A pulse signal is input to AN4-AN7 terminal while one of G-2 line keys on key matrix is touched.

(RD939A3U)

PIN NO.	10,11	SIGNAL	E9,E10	I/O	OUT
---------	-------	--------	--------	-----	-----

Segment data signal.

Signal similar to E6.

(RD939A2U)

PIN NO.	12	SIGNAL	E11	I/O	OUT
---------	----	--------	-----	-----	-----

Segment data signal.

Signal similar to E6.

Key strobe signal.

Signal applied to touch-key section.

A pulse signal is input to AN4-AN7 terminal while one of G-3 line keys on key matrix is touched.

(RD939A3U)

PIN NO.	13	SIGNAL	E12	I/O	OUT
---------	----	--------	-----	-----	-----

Segment data signal.

Signal similar to E6.

Key strobe signal.

Signal applied to touch-key section.

A pulse signal is input to AN4-AN7 terminal while one of G-4 line keys on key matrix is touched.

(RD939A3U)

PIN NO.	14	SIGNAL	E13	I/O	OUT
---------	----	--------	-----	-----	-----

Segment data signal.

Signal similar to E6.

Key strobe signal.

Signal applied to touch-key section.

A pulse signal is input to AN4-AN7 terminal while one of G-5 line keys on key matrix is touched.

(RD939A3U)

PIN NO.	15	SIGNAL	E14	I/O	OUT
Segment data signal. Signal similar to E6. (RD939A2U)					
PIN NO.	16	SIGNAL	E15	I/O	OUT
Segment data signal. Signal similar to E6. Key strobe signal. Signal applied to touch-key section. A pulse signal is input to AN4-AN7 terminal while one of G-6 line keys on key matrix is touched. (RD939A3U)					
PIN NO.	17	SIGNAL	E16	I/O	OUT
Segment data signal. Signal similar to E6. Key strobe signal. Signal applied to touch-key section. A pulse signal is input to AN4-AN7 terminal while one of G-7 line keys on key matrix is touched. (RD939A3U)					
PIN NO.	18	SIGNAL	E17	I/O	OUT
Segment data signal. Signal similar to E6. Key strobe signal. Signal applied to touch-key section. A pulse signal is input to AN4-AN7 terminal while one of G-8 line keys on key matrix is touched. (RD939A3U)					
PIN NO.	19,20	SIGNAL	E18,E19	I/O	OUT
Segment data signal. Signal similar to E6. (RD939A2U)					
PIN NO.	21-24	SIGNAL	E20-E23	I/O	OUT
Used for initial balancing of the bridge circuit(absolute humidity sensor). (RD936A1U)					
PIN NO.	25	SIGNAL	EX	I/O	IN
Internal clock oscillation frequency input setting. The internal clock frequency is set by inserting the ceramic filter oscillation circuit with respect to X terminal. (RD93EA2U)					
PIN NO.	26	SIGNAL	X	I/O	OUT
Internal clock oscillation frequency control output. Output to control oscillation input of EX. (RD93EA1U)					
PIN NO.	27	SIGNAL	RESET	I/O	IN
Auto clear terminal. Signal is input to reset the LSI to the initial state when power is supplied. Temporarily set to "L" level the moment power is supplied, at this time the LSI is reset. Thereafter set at "H" level. (RD93MA2U)					
PIN NO.	28	SIGNAL	SO E24	I/O	OUT
Segment data signal. Signal similar to E6. (RD939A2U)					

PIN NO.	29	SIGNAL	SI E25	I/O	OUT
---------	----	--------	--------	-----	-----

Used for initial balancing of the bridge circuit(absolute humidity sensor).

(RD936A1U)

PIN NO.	30	SIGNAL	E26	I/O	OUT
---------	----	--------	-----	-----	-----

Signal to sound buzzer.

A: Key touch sound.(0.1 sec.)

B: Completion sound.(2.0 sec.)

C: When the temperature of the oven cavity reaches the preset temperature in the preheating mode, or when the preheating hold time (15 minutes) is elapsed.
(1.0 sec. ON-1.0 sec. OFF repeat)

(RD93LA2U)

PIN NO.	31	SIGNAL	IRQ E27	I/O	IN
---------	----	--------	---------	-----	----

Signal synchronized with commercial source frequency(50Hz).

This is the basic timing for time processing of LSI.

(RD93FE1U)

PIN NO.	32	SIGNAL	Vss	I/O	IN
---------	----	--------	-----	-----	----

Power source voltage: -5V.

Vc voltage of power source circuit input.

(RD93GA1U)

PIN NO.	33	SIGNAL	R0	I/O	OUT
---------	----	--------	----	-----	-----

Magnetron high-voltage circuit driving signal.

To turn on and off the cook relay.

In HIGH operation, the signal holds "L" level during microwave cooking and "H" level while not cooking. In other cooking modes (MED. HIGH, MED., MED. LOW, LOW) the signal turns to "H" level and "L" level in repetition according to the power level.

(RD933A2U)

PIN NO.	34	SIGNAL	R1	I/O	OUT
---------	----	--------	----	-----	-----

Oven lamp and turntable motor driving signal.(Square Waveform:50Hz)

To turn on and off the control relay.

The pulse signal(50Hz) is delivered to the control relay driving circuit and cook relay, heater relay control circuit.

(RD932F1U)

PIN NO.	35	SIGNAL	R2	I/O	OUT
---------	----	--------	----	-----	-----

Heating element driving signal.

To turn on and off the heater relay.

"L" level during convection cooking; "H" level otherwise.

During convection cooking or mix cooking, the signal becomes "H" level when the temperature of the oven cavity exceeds the predetermined temperature.

(RD934B4U)

PIN NO.	36	SIGNAL	R3	I/O	OUT
---------	----	--------	----	-----	-----

Cooling fan motor driving signal.

To turn on and off the cooling fan motor relay. "L" level during both microwave and convection cooking; "H" level otherwise.

(RD934B2U)

PIN NO.	37	SIGNAL	R4	I/O	OUT
---------	----	--------	----	-----	-----

Convection motor driving signal.

To turn on and off the convection motor. "L" level during CONVECTION or MIX COOK; "H" level otherwise.

(RD934B8U)

PIN NO.	38	SIGNAL	R5	I/O	OUT
Damper motor relay driving signal.					
To turn on and off the damper motor relay.					
(RD934BBU)					
PIN NO.	39	SIGNAL	R6	I/O	OUT
Digit selection signal.					
Signal similar to E0.					
(RD938A2U)					
PIN NO.	40	SIGNAL	R7	I/O	IN
Input signal which communicates the damper open/close information to LSI.					
Damper opened; "H" level signal.					
Damper closed; "L" level signal.					
(RD937B1U)					
PIN NO.	41	SIGNAL	E37	I/O	IN
Terminal to change functions according to the model.					
Signal in accordance with the model in operation is applied to set up its function.					
(Rd93JA1U)					
PIN NO.	42	SIGNAL	E36	I/O	IN
Input signal which communicates the door open/close information to LSI.					
Door closed; "H" level signal.					
Door opened; "L" level signal.					
(RD937A1U)					
PIN NO.	43	SIGNAL	AVss	I/O	IN
Connected to Vc.					
(RD93KA3U)					
PIN NO.	44	SIGNAL	AVR-	I/O	IN
Reference voltage input terminal.					
A reference voltage applied to the A/D converter in the LSI.					
The reference voltage is generally maintained at -5V.					
(RD93GA4U)					
PIN NO.	45	SIGNAL	AVR+	I/O	IN
Reference voltage input terminal.					
A reference voltage applied to the A/D converter in the LSI.					
Connectd to GND.					
(RD93GA5U)					
PIN NO.	46	SIGNAL	AVcc	I/O	IN
Connected to GND.					
(RD93KA1U)					
PIN NO.	47	SIGNAL	AN7	I/O	IN
Signal coming from touch key.					
When either one of G-12 line keys on key matrix is touched, a corresponding signal out of E7,E8,E11-E13 and E15-E17 will be input into AN7.					
When no key is touched, the signal is held at "L" level.					
(RD93CA1U)					
PIN NO.	48	SIGNAL	AN6	I/O	IN
Signal coming from touch key.					
When either one of G-11 line keys on key matrix is touched, a corresponding signal will be input into AN6.					
(RD93CA2U)					
PIN NO.	49	SIGNAL	AN5	I/O	IN
Signal coming from touch key.					
When either one of G-10 line keys on key matrix is touched, a corresponding signal will be input into AN5.					
(RD93CA2U)					
PIN NO.	50	SIGNAL	AN4	I/O	IN
Signal coming from touch key.					
When either one of G-9 line keys on key matrix is touched, a corresponding signal will be input into AN4.					
(RD93CA2U)					

PIN NO.	51	SIGNAL	AN3	I/O	IN
---------	----	--------	-----	-----	----

Used for initial balancing of the bridge circuit (absolute humidity sensor).

This input is an analog input terminal from the AH sensor circuit, and connected to the A/D converter built into the LSI.

(RD936A3U)

PIN NO.	52	SIGNAL	AN2	I/O	IN
---------	----	--------	-----	-----	----

AH sensor input.

This input is an analog input terminal from the AH sensor circuit, and connected to the A/D converter built into the LSI.

(RD936A2U)

PIN NO.	53	SIGNAL	AN1	I/O	IN
---------	----	--------	-----	-----	----

Temperature measurement input: OVEN THERMISTOR.

By inputting DC voltage corresponding to the temperature detected by the thermistor, this input is converted into temperature by the A/D converter built into the LSI.

(RD935A1U)

PIN NO.	54	SIGNAL	AN0	I/O	IN
---------	----	--------	-----	-----	----

Terminal not used.

(RD93KA2U)

PIN NO.	55	SIGNAL	R8	I/O	OUT
---------	----	--------	----	-----	-----

Terminal not used.

(RD93KA2U)

PIN NO.	56-60	SIGNAL	R9-R13	I/O	IN
---------	-------	--------	--------	-----	----

Terminal not used.

(RD93KA2U)

PIN NO.	61	SIGNAL	R14	I/O	IN
---------	----	--------	-----	-----	----

Terminal not used. Connected to GND.

(RD93KA5U)

PIN NO.	62	SIGNAL	R15	I/O	IN
---------	----	--------	-----	-----	----

Terminal for manufacture test.

Normally terminal not used.

(RD93IA3U)

PIN NO.	63	SIGNAL	NC	I/O	NC
---------	----	--------	----	-----	----

Terminal not used.

(RD93KA2U)

PIN NO.	64	SIGNAL	Vcc	I/O	IN
---------	----	--------	-----	-----	----

Connected to GND.

(RD93KA1U)

ABSOLUTE HUMIDITY SENSOR CIRCUIT

(1) Structure of Absolute Humidity Sensor

The absolute humidity sensor includes two thermistors as shown in the illustration. One thermistor is housed in the closed vessel filled with dry air while another in the open vessel. Each sensor is provided with the protective cover made of metal mesh to be protected from the external airflow.

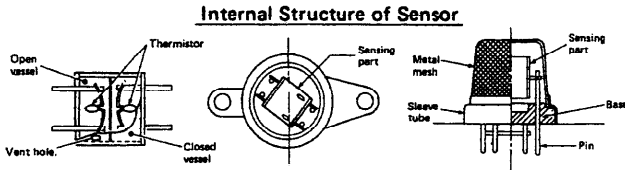

(2) Operational Principle of Absolute Humidity Sensor

The figure below shows the basic structure of an absolute humidity sensor. A bridge circuit is formed by two thermistors and two resistors (R1 and R2).

The output of the bridge circuit is to be amplified by the operational amplifier.

Each thermistor is supplied with a current to keep it heated at about 150 °C (302 °F) and the resultant heat is dissipated in the air and if the two thermistors are placed in different humidity conditions they show different degrees of heat conductivity leading to potential difference between them causing an output voltage from the bridge circuit, the intensity of which is increased as the absolute humidity of the air increases. Since the output is very minute, it will be amplified by the operational amplifier.

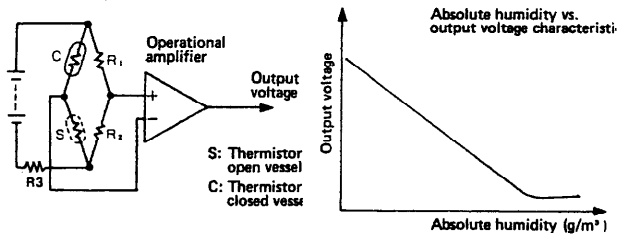

(3) Detector Circuite of Absolute Humidity Sensor Circuit

This detector circuit is used to detect the output voltage of the absolute humidity circuit to allow the LSI to control sensor cooking of the unit.

When the unit is set in the sensor cooking mode, 16 seconds later the detector circuit starts to function and the LSI observes the initial voltage available at its AN2 terminal. With this voltage given, the switches SW1 to SW5 in the LSI are turned on in such a way as to change the resistance values in parallel with R50.

-1. Changing the resistance values results in that there is the same potential at both F-3 terminal of the absolute humidity sensor and AN3 terminal of the LSI. The voltage of AN2 terminal will indicate about -2.5V. This initial balancing is set up about 16 seconds after the unit is put in the Sensor Cooking mode.

As sensor cooking proceeds, the food is heated to generate moisture by which the resistance balance of the bridge circuit to deviate increasing the voltage available at AN2 terminal of the LSI. Then the LSI observes that voltage at AN2 terminal and compares it with its initial value, and when the comparison rate reaches the preset value (fixed for each menu to be cooked), the LSI causes the unit to stop sensor cooking; thereafter, the unit goes into the next necessary operation automatically.

When the LSI starts to detect the initial voltage at AN2 terminal 16 seconds after the unit has been put in the Sensor Cooking mode, if it is impossible to take a balance of the bridge circuit due to disconnection of the absolute humidity sensor, ERROR will reappear on the display and the cooking is stopped.

(RD72Q01U)

1) Absolute humidity sensor circuit

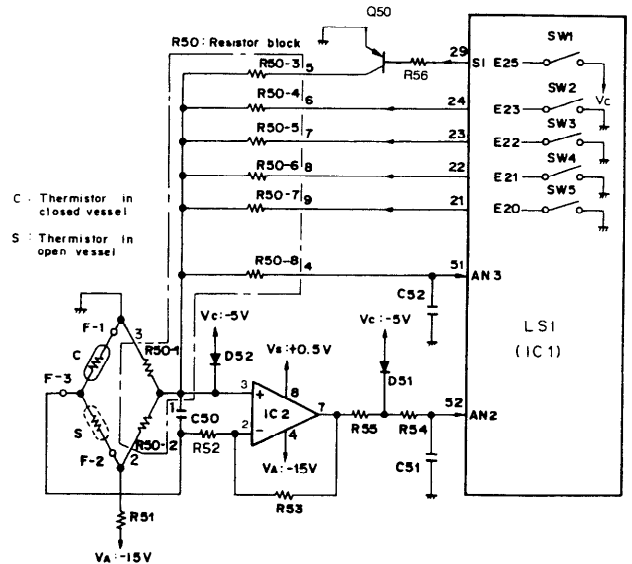

2) Internal equivalent circuit of I2

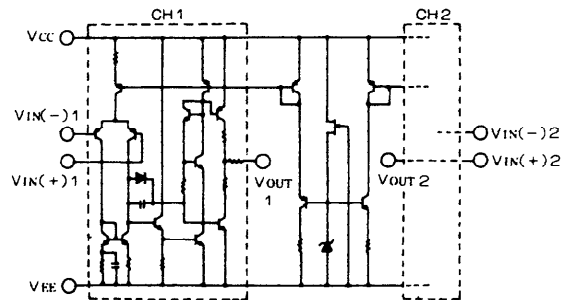

Top View

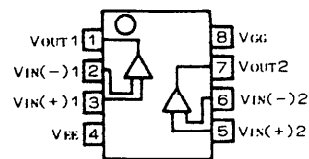

SERVICING

1. Precautions for Handling Electronic Components

This unit uses PMOS LSI in the integral part of the circuits. When handling these parts, the following precautions should be strictly followed.

PMOS LSI have extremely high impedance at its input and output terminals. For this reason, it is easily influenced by the surrounding high voltage power source, static electricity charged in clothes, etc., and sometimes it is not fully protected by the built-in protection circuit.

In order to protect PMOS LSI.

- 1) When storing and transporting, thoroughly wrap them in aluminum foil.

Also wrap PW boards containing them in aluminium foil.

- 2) When soldering, ground the technician as shown in the figure and use grounded soldering iron and work table.

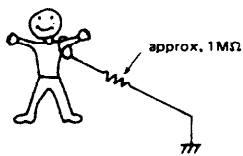

2. Shapes of Electronic Components



Transistor
2SB793

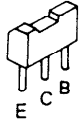

Transistor
2SA937
DTD143A



Transistor
DTA143ES
DTA114YS
DTC114ES

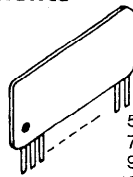

Resistor Block,
R50, R90, R110
R112

3. Servicing of Touch Control Panel

We describe the procedures to permit servicing the touch control panel of the microwave oven and the cautions you must consider when doing so.

To carry the servicing, power supply to the touch control panel is available either from the power line of the oven proper itself or from an external power source.

- (1) Servicing the touch control panel with power supply from the oven proper:

CAUTION:

THE HIGH VOLTAGE TRANSFORMER OF THE MICROWAVE OVEN IS STILL ALIVE TO GIVE YOU DANGER DURING SERVICING.

Therefore, when checking the performance of the touch control panel, put the outer cabinet on the oven proper to keep from touching the high voltage transformer, or unplug the primary terminal (connector) of the high voltage transformer to turn it off; and the end of such connector shall be insulated with an insulating tape. After servicing, be sure to replace the leads to their original locations.

- A. On some models, the power supply cord between the touch control panel and the oven proper is so short that they can't be separated from each other.

For those models, therefore, check and repair all the controls (with the sensor-related ones included) of the touch control panel while keeping it in contact with the oven proper.

- B. On some models, on the other hand, the power supply cord between the touch control panel and the oven proper is so long that they may be separated from each other. For those models, therefore, it is allowed to check and repair the controls of the touch control panel while keeping it apart from the oven proper; in this case you must short both ends of the door sensing switch (on PWB) of the touch control panel with a jumper, which brings about an operational state that is equivalent to that with the oven door being closed.

As to the sensor-related controls of the touch control panel, their checking is allowed if the dummy resistor(s) whose resistance is equal to that of those controls is used.

- (2) Servicing the touch control panel with power supply from an external power source:

Disconnect the touch control panel completely from the oven proper, and short both ends of the door sensing switch (on PWB) of the touch control panel, which brings about an operational state that is equivalent with the oven door being closed. And connect an external power source to the power input terminal of the touch control panel, and then it is allowed to check and repair the controls of the touch control panel; as in the case of (1)-B above, it is here also possible to check the sensor-related controls of the touch control panel by using the dummy resistor(s).

4. Servicing Tools

Tools required when servicing the touch control panel assembly.

- 1) Soldering iron: 30W
(To prevent leaking current, it is recommended to use a soldering iron with a grounding terminal.)
- 2) Oscilloscope: Single beam, frequency range: DC - 10MHz type or more advanced model.
- 3) Others: Hand tools

5. Other Precautions

- 1) Before turning on the power source of the control unit, remove the aluminum foil applied for preventing static electricity.
- 2) Connect the connectors of the indicator and key units to the control unit taking care that the lead wires are not twisted.
- 3) After aluminum foil is removed, take extra care that abnormal voltage due to static electricity etc. is not applied to the input or output terminals.
- 4) Attach connectors, electrolytic capacitors, etc. to PWB, taking care that all connections are tight.
- 5) Be sure to use specified components where high precision is required.

(RD94ZA2U)

COMPONENT REPLACEMENT AND ADJUSTMENT PROCEDURE

WARNING: To avoid possible exposure to microwave energy;

- A. Before operating the oven
1. Make sure that unlatching the door slowly is accompanied by a click indicating actuation of the monitor switch and latch switches.
 2. Check visually the door seal for arcing and damage.
- B. Do not operate the oven until after repair if any of the following conditions exist;
1. Door does not close firmly against the front of appliance.
 2. There is a broken door hinge or support.
 3. The door is bent or warped.

4. There is any defective parts in the interlock, oven door or microwave generating and transmission assembly.
 5. There is any other visible damage to the oven.
- C. Do not operate the oven
1. Without the RF gasket.
 2. If the door is not closed.

CAUTION: DISCONNECT OVEN FROM POWER SUPPLY BEFORE REMOVING OUTER CASE. DISCHARGE HIGH VOLTAGE CAPACITOR BEFORE TOUCHING ANY OVEN COMPONENTS OR WIRING.

(RDA1203U)

POWER TRANSFORMER REMOVAL

1. Disconnect oven from power supply and remove outer case.
2. Discharge high voltage capacitor.
3. Disconnect filament leads of transformer from the magnetron.
4. Disconnect wire leads from the transformer.
5. Remove two (2) screws and one (1) washer holding the transformer to the cabinet base.

Re-install

1. Rest the transformer on the base cabinet with its primary terminals toward rear cabinet.
2. Insert the two edges of the transformer into two metal tabs of the base cabinet.

3. Make sure the transformer is mounted correctly to the corners underneath those tabs
4. After re-installing the transformer, secure the transformer with two screws to the cabinet base, one is with outertooth washer and the other is without outer-tooth washer.
5. Re-connect the wire leads (primary and high voltage) to the transformer and filament leads of transformer to the magnetron, referring to the "Pictorial Diagram".
6. Re-install the outer case and check that the oven is operating properly.

HIGH VOLTAGE RECTIFIER REMOVAL

1. Disconnect oven from power supply and remove outer case.
2. Discharge the high voltage capacitor.
3. Remove one (1) screw holding the rectifier to the capacitor holder.
4. Disconnect the rectifier from the capacitor.

CAUTION: WHEN REPLACING THE SILICON RECTIFIER, THE GROUND SIDE TERMINAL MUST BE SECURED FIRMLY WITH A GROUNDING SCREW.

HIGH VOLTAGE CAPACITOR REMOVAL

1. Disconnect oven from power supply and remove outer case.
2. Discharge the high voltage capacitor.
3. Disconnect the high voltage wire leads from high voltage capacitor.
4. Remove one (1) screw holding capacitor mounting bracket.

5. Disconnect rectifier and high voltage rectifier from the capacitor.
6. Remove one (1) screw holding the high voltage rectifier and the capacitor holder.
7. Remove the capacitor from the holder.

TURNTABLE MOTOR AND/OR COUPLING REMOVAL

1. Disconnect the oven from power supply.
2. Remove one (1) screw holding the turntable motor cover to the base cabinet and take off the turntable motor cover.
3. Disconnect 2-pin connector from the turntable motor.

4. Remove the two (2) screws holding the turntable motor to the mounting plate of the oven cavity.
5. Pull the turntable coupling out of the oven cavity.
6. The turntable motor is now free.

MAGNETRON REMOVAL

1. Disconnect oven from power supply and remove outer case.
2. Discharge the high voltage capacitor.
3. Disconnect wire leads from the magnetron.
Remove the magnetron temp. fuse fitted to waveguide flange. And release the wire leads from the hole of magnetron cooling duct (B). And release the AH sensor harness from hole of chassis support. Remove four (4) screws holding the chassis support to cooling duct (A), waveguide, rear cabinet, control back plate.
4. Release the tab on cooling duct (B) to hold cooling duct (A).
5. Carefully remove four (4) mounting screws holding the magnetron to waveguide, when remove the

- screws, a careful attention should be necessary to prevent the magnetron fall away.
6. Remove the magnetron (with magnetron cooling duct(B)) from the unit with a careful attention the magnetron tube should not hit by any metal object around the tube.
 7. Remove one (1) screw holding cooling duct (B) to the magnetron.
 8. Remove cooling duct (B) from the magnetron.
 9. Now the magnetron is free.
- CAUTION:** WHEN REPLACING THE MAGNETRON, BE SURE THE R.F. GASKET IS IN PLACE AND THE MAGNETRON MOUNTING SCREWS ARE TIGHTENED SECURELY.

CONVECTION MOTOR REMOVAL

1. Disconnect oven from power supply and remove outer case.
2. Discharge the high voltage capacitor.
3. Remove sliding the thermal cut-out with its wire lead on.
4. Disconnect wire leads from the convection motor and convection heater.
5. Disconnect the 2-pin connector from thermistor.
6. Remove eleven (11) screws holding the heater duct to the oven cavity.
7. Remove two (2) screws holding the heater duct to thermal protection plate (bottom).
8. The heater unit is now free.
9. Remove the four (4) screws holding the thermal protection plate(left) to the heater duct.
10. The thermal protection plate(left) and sheet(left) are now free.
11. Remove three (3) screws holding the convection motor mounting plate to the heater duct.
12. Pull the convection motor shaft out of convection fan.
13. Now the convection motor with the motor mounting plate is free.

14. Remove two (2) nuts holding the motor mounting plate to the convection motor.
15. Convection motor is now free.

Re-install

1. Re-install the convection motor mounting plate to the convection motor by the two (2) nuts.
2. Put the convection fan to the motor shaft.(fit with a E-ring.)
3. Re-install the heater duct to the convection motor mounting plate by the three (3) screws.
4. Make sure the rotation of the convection motor.
5. Re-install the thermal protection plate to cover the heater duct with sandwiching the thermal protection sheet.
6. Re-install the heater unit to the left side of the oven cavity by the eleven (11) screws. Re-install the heater unit to thermal protection plate (bottom) by two (2) screws.
7. Re-install the wire leads to the convection motor, convection heater, thermistor connector. Referring to "Pictorial diagram".
8. Re-install the thermal cut-out.

COOLING FAN MOTOR REMOVAL

1. Disconnect oven from power supply and remove outer case.
2. Discharge the high voltage capacitor.
3. Disconnect wire leads from the cooling fan motor.
4. Release AH sensor harness from chassis support and cooling duct (A).
5. Remove four (4) screws holding the chassis support to rear cabinet, cooling duct (A), waveguide flange and control panel back plate.

6. Release the tab on cooling duct (B) holding cooling duct (A).
7. Remove duct (A) with the cooling fan motor from the unit.
The cooling fan motor assembly is now free.
8. Remove the fan blade from the cooling fan motor shaft by pulling out the fan retainer clip.
9. Remove two (2) screws and nuts holding cooling fan motor to the cooling duct (A).
The cooling fan motor is now free.

DAMPER ASSEMBLY REMOVAL

1. Disconnect oven from power supply and remove outer case.
2. Discharge the high voltage capacitor.
3. Disconnect wire leads from damper motor and damper switch.
4. Do above the MAGNETRON REMOVAL from No.3 to No.6.
5. Remove one (1) screw holding the magnetron air guide to waveguide flange.
6. Remove the magnetron air guide.
7. Raise the stopper of the damper shaft, and pull out the damper shaft.
8. Pull the damper ass'y out of the thermal protection plate(right).
9. Remove one (1) screw holding the motor to the damper.
10. The damper is now free.
11. Remove one (1) screw holding the damper switch to the damper.
12. Now, the damper switch is free.

CONVECTION HEATER OR CONVECTION FAN REMOVAL

1. Do CONVECTION MOTOR REMOVAL from No.1 to No.10.
2. Remove five (5) screws holding the convection air guide (4-40,4-41,4-42,4-45) to the heater duct.
3. Remove four (4) screws holding the convection air guide (4-38) to the heater duct.
4. The convection air guide is now free.
5. Remove two (2) screws holding heating element holders to the heater duct and remove them.
6. Remove two (2) screws holding convection heater to heater duct.
7. Pull the convection heater out of the heater duct.
8. Now the convection heater is free.

CONVECTION FAN

1. Do CONVECTION MOTOR REMOVAL from No.1 to No.13.
2. Remove two (2) screws holding the shaft mounting plate ass'y to the heater duct.
3. Pull the convection fan and washer out of the heater duct.
4. Convection fan is now free.

UPPER LATCH SWITCH / MONITOR SWITCH REMOVAL

1. Disconnect oven from power supply and remove outer case.
2. Discharge the high voltage capacitor.
3. Disconnect the wire leads from the switches.
4. Remove the one (1) screw holding the upper latch hook to the oven flange.
5. Remove the upper latch hook assembly from oven flange.
6. Push outward on the two (2) retaining tabs holding the switch in place.
7. The switch is now free.

Re-install

1. Re-install each interlock switch in its place. The monitor switch is in the upper position and the upper latch switch is in the lower position.
2. Re-connect the wire leads to each switch. Refer to the pictorial diagram.
3. Secure the upper latch hook (with the one (1) mounting screw) to the oven flange.
4. Make sure that the monitor switch and upper latch switch are operating properly. Refer to chapter "Test Procedure" and "Adjustment procedure".

(RDA1203U)

LOWER LATCH SWITCH AND STOP SWITCH REMOVAL

1. Disconnect the oven from the power supply and remove the outer case.
2. Discharge the high voltage capacitor.
3. Disconnect the wire leads from the switches.
4. Remove the one (1) screw holding the lower latch hook to the oven cavity front frange.
5. Remove the lower latch hook from the flange by moving it downward.
6. To remove the individual switch from the lower latch hook, push outward the two (2) retaining tabs holding the switch in place.
7. The switch is now free.

Re-install

1. Re-install each interlock switch in its place. The stop switch is in the upper position and the lower latch switch is in the lower position.
2. Re-connect the wire leads to each switch. Refer to the pictorial diagram.
3. Secure the lower latch hook (with the one (1) mounting screws) to the oven flange.
4. Make sure that the lower latch switch and stop switch are operating properly. Refer to chapter "Test Procedure" and "Adjustment procedure".

(RDA1203U)
(RDA1203U)

CONTROL PANEL ASSEMBLY AND CPU UNIT REMOVAL

The complete control panel should be removed for replacement of components except the relay unit.

To remove the control panel, proceed as follows:

1. Disconnect oven from power supply and remove outer case.
2. Discharge the high voltage capacitor.
3. Disconnect the wire connectors and wire leads from the relay unit and CPU unit.
4. Disconnect a connector from the CPU unit.
5. Remove one (1) screw holding the control panel back plate to the chassis support.
6. Remove the two (2) screws holding the bottom edge of the back plate to the cabinet base.
7. Remove one (1) screw holding the back plate to the oven cavity flange.
8. Lift up and pull the control panel forward.

Replacement of individual component is as follows:

CPU UNIT AND KEY UNIT

1. Disconnect the wire connector of CPU unit from the relay unit.
2. Remove the four (4) screws holding the panel frame to the back plate.
3. Separate the panel frame and back plate.
4. Remove the three (3) screws holding the CPU unit to the panel frame.
5. Lift up the control unit and disconnect the key connector from the CPU unit.
6. Now, the CPU unit and frame assembly are separated.

UPPER LATCH/LOWER LATCH/STOP SWITCHES AND MONITOR SWITCH ADJUSTMENT

If the upper latch, lower latch switches stop switch and monitor switch do not operate properly due to a mis-adjustment, the following adjustment should be made.

1. Loosen the one (1) screw holding the upper latch hook to the oven cavity front flange and the one (1) screw holding the lower latch hook to the same flange.
2. With the door closed, adjust the lower latch hook by moving it back and forth and then adjust the upper latch hook by moving it back and forth, or up and down. In and out play of the door allowed by the upper and lower latch hooks should be less than 0.5 mm. The vertical position of the upper latch hook should be placed where the upper latch switch and monitor switch have activated with the door closed. Vertical adjustment of the lower latch hook is not possible.
3. Secure the screws with washers firmly.
4. Now, make sure of the upper latch switch operation. If the upper latch switch has not activated with the door closed, loose the one (1) screw holding the upper latch hook to the oven cavity front flange and adjust the upper latch hook position.

2. The upper latch and lower latch switches interrupt the circuit before the door can be opened.
3. The monitor switch contacts close when the door is opened.
4. Re-install the outer case and check for microwave leakage around the door with an approved microwave survey meter. (Refer to Microwave Measurement Procedure.)

After the adjustment, make sure of the following:

1. The in and out play of the door remains less than 0.5 mm at latched position. First check the upper latch hook position, pushing and pulling the upper portion of door toward the oven face. Then check the lower latch hook position, pushing and pulling the lower portion of door toward the oven face. Both results (plays of the door) should be less than 0.5mm.

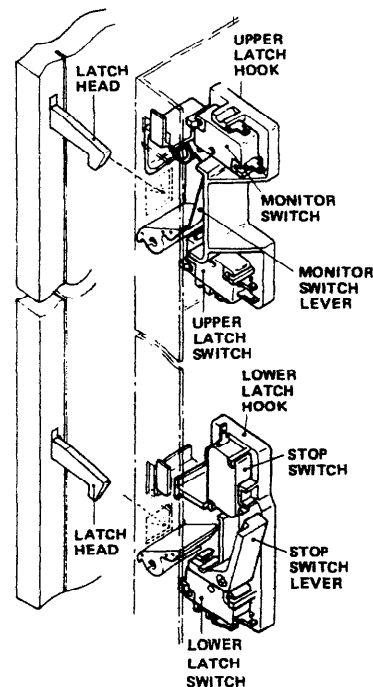

Figure C-1. Latch Switches Adjustment

(RDA1203U)

DOOR REPLACEMENT AND ADJUSTMENT

DOOR REPLACEMENT

1. Disconnect oven from power supply and remove outer case.
2. Holding the door, remove three (3) screws securing the upper door hinge to the oven cavity. The door assembly is now free from the oven cavity.
3. On re-installing new door assembly, secure the door assembly with the three (3) mounting screws to the oven cavity.

Make sure the door is parallel with the bottom line of the oven face plate and the latch heads pass through the latch holes correctly.

Note: After any service to the door, an approved microwave survey meter should be used to assure compliance with proper microwave radiation standard. (Refer to Microwave Measurement Procedure).

Note: If the Latch Heads Need Removal, "TORX T-20" or "LHXTIX LR-3" Type screwdriver should be used.

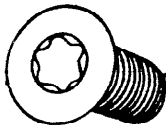

TORX screw

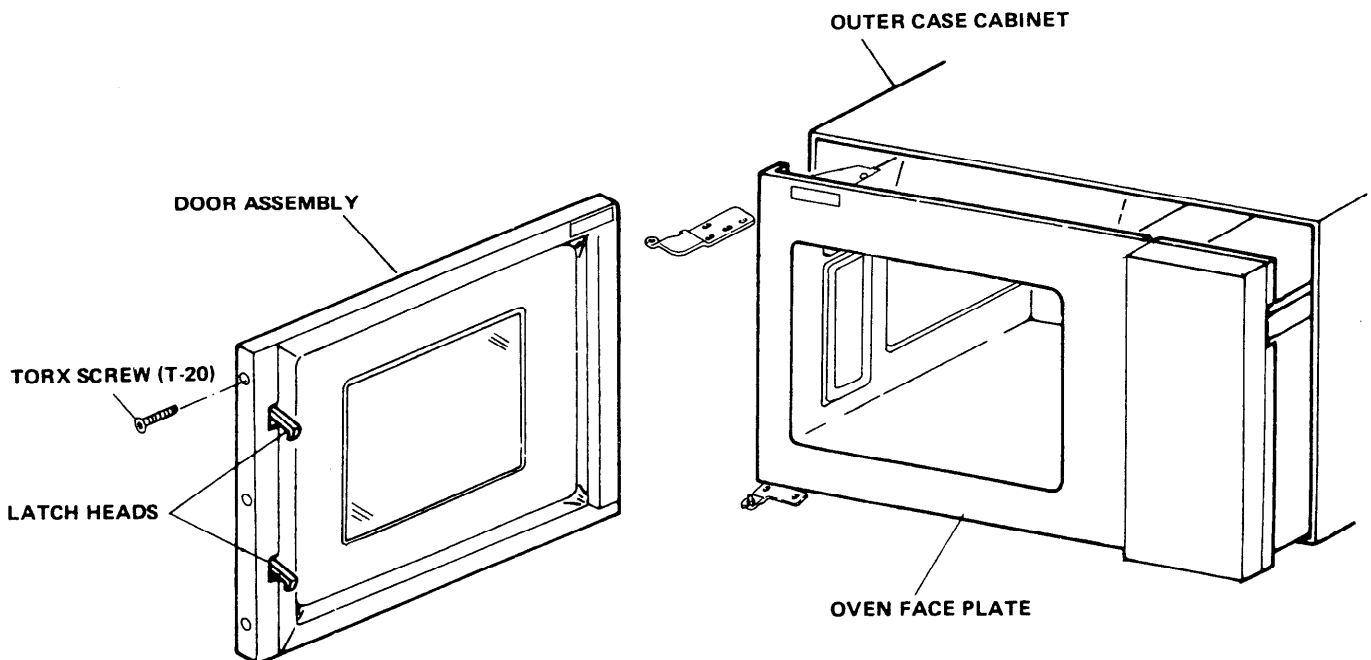

Figure C-2. Door Assembly Replacement and Adjustment

(RDA1203U)

DOOR ADJUSTMENT

When removing and/or loosening hinges such as in the case of a door replacement, the following adjustment criteria are taken. Door is adjusted to meet the following three conditions before tightening the hinge screws.

1. Adjust door latch heads at a position where they smoothly catch the latch hooks through the latch holes. Refer to upper latch and lower latch switches adjustments.
2. Deviation of the door alignment from the horizontal line of cavity face to be less than 1mm.
3. Door should be adjusted with its face depressed toward cavity face.

After hinge screws are tightened under foregoing conditions, recheck 1 and 2.

Note: The door on a microwave oven is designed to act as an electronic seal preventing the leakage of microwave energy from the oven cavity during the cookcycle. This function does not require that the door be airtight, moisture condensation tight or light-tight. Therefore, the occasional appearance of moisture, light or the sensing of gentle air movement around the oven door is not abnormal and do not of themselves, indicate a leakage of microwave energy from the oven cavity. If such were the case, your oven could not be equipped with a vent, the very purpose of which is to exhaust the vapor-laden air from the oven cavity.

MICROWAVE MEASUREMENT

After adjustment of door latch switches, monitor switch and door are completed individually or collectively, the following leakage test must be performed with a survey instrument and it must be confirmed that the result meets the requirements of the performance standard for microwave oven.

REQUIREMENT

The safety switch must prevent microwave radiation emission in excess of 5mW/cm² at any point 5cm or more from external surface of the oven.

PREPARATION FOR TESTING:

Before beginning the actual test for leakage, proceed as follows:

1. Make sure that the test instrument is operating normally as specified in its instruction booklet.
Important:
Survey instruments that comply with the requirement for instrumentations as prescribed by the performance standard for microwave ovens must be used for testing.

Recommended instruments are:

NARDA 8100
NARDA 8200
HOLADAY HI 1500
SIMPSON 380M

2. Place the oven tray into the oven cavity.
3. Place the load of 275 \pm 15ml of water initially at 20 \pm 5 °C in the center of the oven tray. The water container should be a low form of 600 ml beaker with inside diameter of approx. 8.5cm and made of an electrically non-conductive material such as glass or plastic.
The placing of this standard load in the oven is important not only to protect the oven, but also to insure that any leakage is measured accurately.
4. Close the door and turn the oven ON with the timer set for several minutes. If the water begins to boil before the survey is completed, replace it with 275ml of the cool water.
5. Move the probe slowly (not faster than 2.5cm/sec.) along the gap.
6. The microwave radiation emission should be measured at any point of 5cm or more from the external surface of the oven.

(RDB1103U)

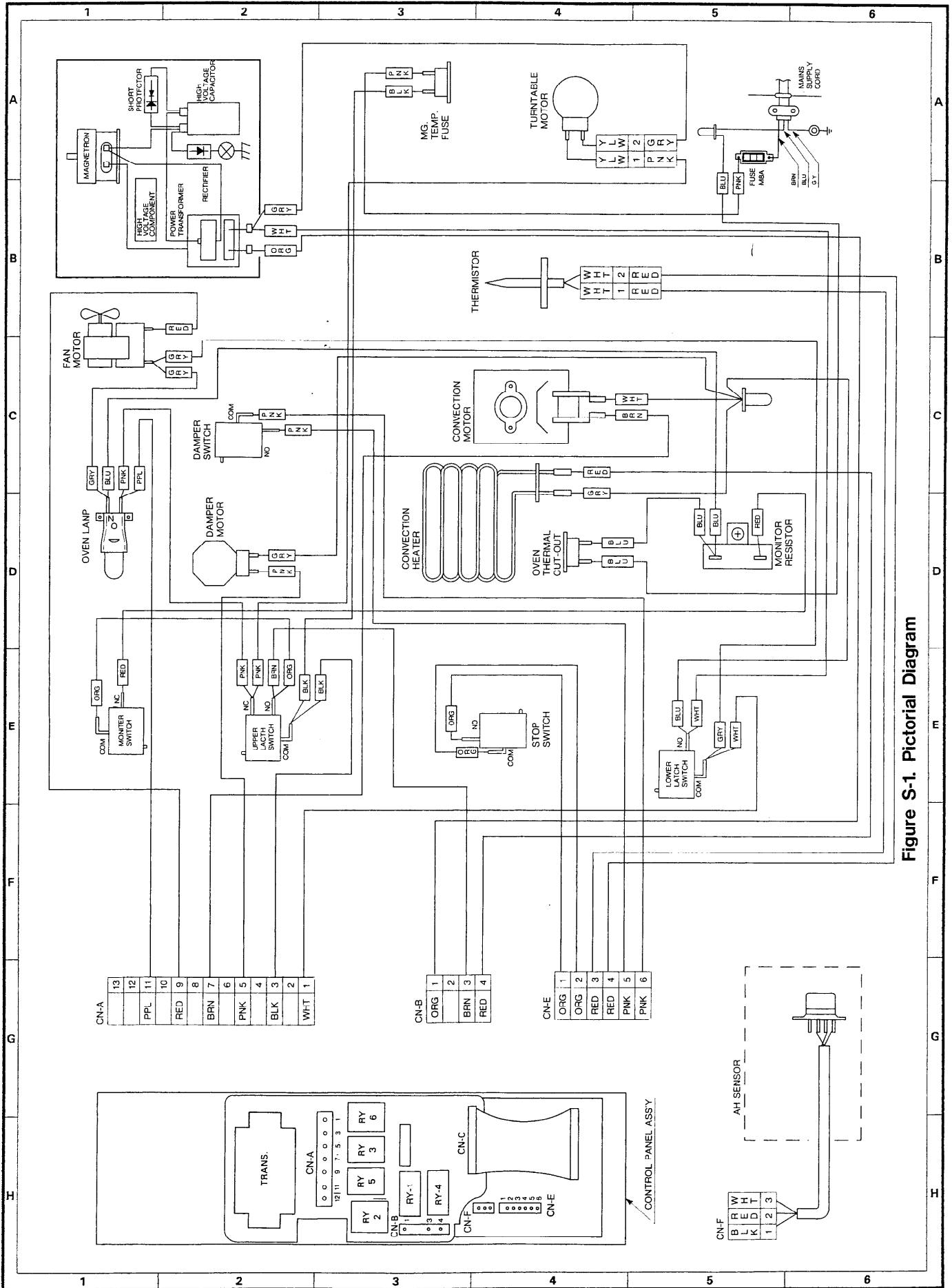

Figure S-1. Pictorial Diagram

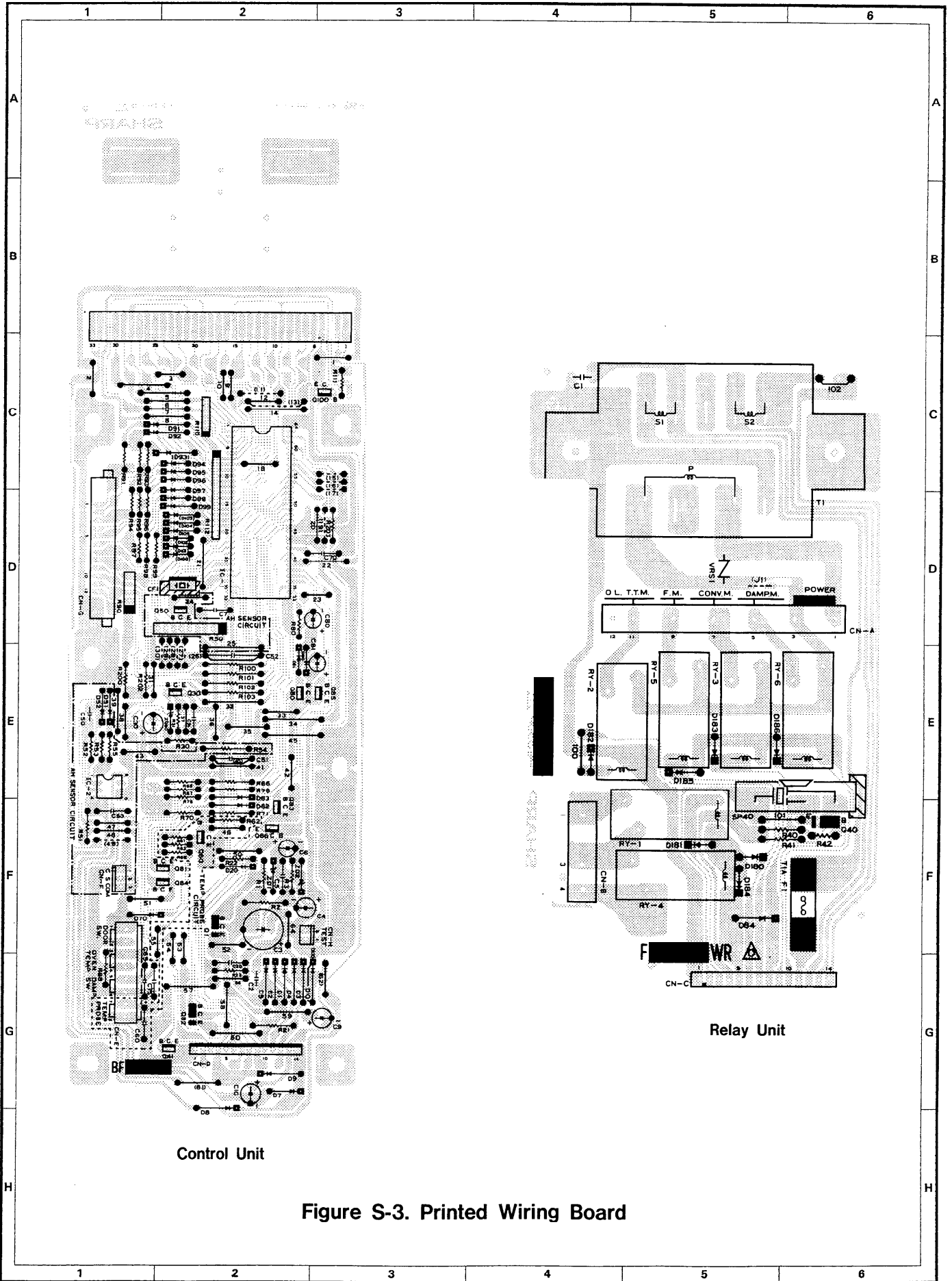

Figure S-3. Printed Wiring Board

PARTS LIST

Note: The voltage supplied to the parts "*" are greater than 250V.

★ Refer to "REPLACEMENT PARTS LIST" described at after PARTS LIST.

REF. NO.	PART NO.	DESCRIPTION	Q'TY	CODE
ELECTRICAL PARTS				
1- 1	QACCA0032WRE0	Power supply cord	1	AR
1- 2	QSW-MA017WRE0	Monitor switch	1	AF
1- 3	QFSDA002WRE0	Fuse holder	1	AE
1- 4	QFS-T0023WRE0	Magnetron temp. fuse	1	AG
1- 5	QSW-MO174WRE0	Damper switch and stop switch	2	AH
1- 6	QSW-MA020WRE0	Upper latch switch	1	AF
1- 7	RTHM-0054WRE0	Thermal cut-out	1	AG
1- 8	RLMPT0018WRE0	Oven lamp	1	AN
1- 9	QSOCLA001WRE0	Oven lamp socket	1	AH
1-10	RMOTDA048WRE0	Turntable motor	1	AW
1-11	RMOTDA043WRE0	Damper motor	1	AQ
1-12	RMOTEA070WRE0	Convection motor	1	AW
1-13	RMOTEA017WRE0	Cooling fan motor	1	AW
1-14	RHET-A030WRE0	Convection heater	1	AY
1-15	RTRN-A139WRE0	Power transformer	1	BQ
* 1-16	RC-QZA029WRE0	High voltage capacitor	1	AY
* 1-17	RH-DZA008WRE0	High voltage rectifier	1	AK
* 1-18	RV-MZA008WRE0	Magnetron	1	BL
1-19	FH-HZA005WRE0	Thermistor	1	AV
1-20	FDTCTA050WRK0	AH sensor	1	BB
1-21	QSW-MA018WRE0	Lower latch switch	1	AF
1-22	RR-WZ0025WRE0	Monitor resistor	1	AH
1-23	RH-DZA012WRE0	Rectifier	1	AQ
1-24	QFS-CA010WRE0	Fuse (M8A)	1	AE

CABINET PARTS

2- 1	FDAI-A066WRY0	Base cabinet	1	AX
2- 2	GCOVHA092WRW0	Turntable motor cover	1	AC
2- 3	GLEGPO009YBE0	Foot	4	AB
2- 4	PREF-A002WRE0	Reflection sheet	1	AD
2- 5	GCABDA027WRW0	Rear cabinet	1	AV
2- 6	PCUSU0263WRP0	Vibration proof cushion	2	AA
2- 7	LSTPP0008YBFO	Cord anchorage (upper)	1	AC
2- 8	LSTPP0009YBFO	Cord anchorage (lower)	1	AC
2- 9	GCABUA141WRS0	Outer case cabinet	1	BC
2-10	PCUSU0337WRP0	Shading cushion	1	AA
2-11	TMAPCA302WRRO	Schematic diagram	1	AC
2-12	GCOVAA081WRW0	Base cover	1	AF
2-13	LBSHC0032WRE0	Cord bushing	1	AB
2-14	LHLDK0005YBFO	Cord holder	1	AB
2-15	FFTASA014WRK0	Oven lamp access cover assembly	1	AH
2-15A	GFTASA014WRP0	Oven lamp access cover	1	AG
2-15B	PCUSGA077WRP0	Cushion	1	AC
2-15C	PSLDPA001WRP0	Reflection tape	1	AB

CONTROL PANEL PARTS

3- 1	CPWBFA095WRK0	Control unit	1	BV
3- 1A	QCNCMA086DRE0	14-pin connector (D)	1	AD
3- 1B	QCNCMA040DRE0	6-pin connector (E)	1	AC
3- 1C	QCNCMA039DRE0	3-pin connector (F)	1	AB
3- 1D	QCNCMA030DRE0	12-pin connector (G)	1	AE
3- 1F	RV-KXA002DRE0	Fluorescent display tube	1	BC
C2	RC-KZA032DRE0	Capacitor 0.1 μ F 50V	1	AB
C3	RC-EZA131DRE0	Capacitor 1000 μ F 35V	1	AE
C4	RC-EZA061DRE0	Capacitor 4.7 μ F 50V	1	AB
* C5, 7, 20,	RC-KZA004DRE0	Capacitor 0.015 μ F 25V	1	AB
C31, C65			10	AA
C51-C53				
C70, C75				

Note : The voltage supplied to the parts "*" are greater than 250V.

★ Refer to "REPLACEMENT PARTS LIST" described at after PARTS LIST.

REF. NO.	PART NO.	DESCRIPTION	Q'TY	CODE
*C6	RC-EZA059DRE0	Capacitor 10 μ F 25V	1	AB
*C9	RC-EZA057DRE0	Capacitor 100 μ F 16V	1	AB
*C10	RC-EZA058DRE0	Capacitor 22 μ F 25V	1	AB
*C30	RC-EZA060DRE0	Capacitor 47 μ F 16V	1	AB
*C50	RC-KZ104QDRE0	Capacitor 0.1 μ F 25V	1	AB
*C80	RC-EZA063DRE0	Capacitor 0.47 μ F 50V	1	AB
*C81	RC-EZA062DRE0	Capacitor 3.3 μ F 50V	1	AB
CF1	RCRS-A003DRE0	Ceramic filter(4.0MHZ)	1	AF
D1-D5, D8-D10	RH-DZA029DRE0	Diode(1N4002)	8	AA
D7,20,51 D52,D70, D80-D83, D91,D92, D94-D99,	RH-DZA024DRE0	Diode(US1060M)	17	AA
IC1	RH-IZA096DRE0	LSI	1	AW
IC2	RH-IZ0021WRE0	IC(IR94558)	1	AE
Q1	RH-TZA035DRE0	Transistor 2SB793(Q,R)	1	AC
Q30,Q41, Q81,	RH-TZA046DRE0	Transistor DTA143ES	7	AC
Q83-Q86, Q50,Q100 Q80	RH-TZA044DRE0	Transistor 2SA933S	2	AB
Q82	RH-TZA047DRE0	Transistor DTA114Y	1	AC
R1	RH-TZA051DRE0	Transistor DTD143A	1	AC
R2	RR-DZ331NDRE0	Resistor 330 Ω 1/4W	1	AA
R2	RR-SZ820RDRE0	Resistor 82 Ω 1W	1	AA
R3	RR-DZ561PDRE0	Resistor 560 Ω 1/2W	1	AA
R21,R55, R56 R91,R92,	RR-DZ103NDRE0	Resistor 10k Ω 1/4W	16	AA
R94-R99, R100 -R104				
R22,R54,	RR-DZ473NDRE0	Resistor 47k Ω 1/4W	2	AA
R23,R31	RR-DZ153NDRE0	Resistor 15k Ω 1/4W	2	AA
R30	RR-DZ471NDRE0	Resistor 470 Ω 1/4W	1	AA
R50	RR-DZA069DRE0	Resistor block(RNAF9T)	1	AD
R51	RR-DZ331PDRE0	Resistor 330 Ω 1/2W	1	AA
R52	RR-NZ182NDRE0	Resistor 1.8k Ω (F) 1/4W	1	AA
R53	RR-NZ304NDRE0	Resistor 300k Ω (F) 1/4W	1	AA
R65	RR-NZ151NDRE0	Resistor 150 Ω (F) 1/4W	1	AA
R66,R71, R76,R80, R203	RR-DZ102NDRE0	Resistor 1.0k Ω 1/4W	5	AA
R67	RR-NZ362NDRE0	Resistor 3.6k Ω (F) 1/4W	1	AA
R68	RR-DZ184NDRE0	Resistor 180k Ω 1/4W	1	AA
R70,R75, R111	RR-DZ273NDRE0	Resistor 27k Ω 1/4W	3	AA
R90	RR-DZA052DRE0	Resistor block(100k Ω x4)	1	AB
R110	RR-DZA027DRE0	Resistor block(27k Ω x6)	1	AC
R112	RR-DZA030DRE0	Resistor block(56k Ω x15)	1	AD
ZD1	RH-EZA050DRE0	Zener diode (RD16EB3)	1	AB
ZD2	RH-EZA051DRE0	Zener diode (RD5.1EB3)	1	AB
ZD30	RH-EZA052DRE0	Zener diode (RD3.6EL2)	1	AB
3-2	DPWBFA276WRK0	Relay unit	1	BG
3-2A	QCNCMA108DRE0	7-pin connector(A)	1	AE
3-2B	QCNCMA115DRE0	3-pin connector(B)	1	AF
3-2C	QCNCMA109DRE0	14-pin connector assembly(C)	1	AL
C1	RC-KZA032DRE0	Capacitor 0.1 μ F 50V	1	AB
D84,	RH-DZA024DRE0	Diode (US1060M)	8	AA
D180-186 Q40	RH-TX825AKRE0	Transistor 2SA937(Q)	1	AB
R40	RR-DZ154NDRE0	Resistor 150k Ω 1/4W	1	AA
R41	RR-DZ471NDRE0	Resistor 470 Ω 1/4W	1	AA
R42	RR-DZ103NDRE0	Resistor 10k Ω 1/4W	1	AA
RY1-RY6	RRLY-A013DRE0	Relay OMI-SH112D	6	AM
SP40	RALM-A008DRE0	Buzzer PKM30SP	1	AH
T1	RTRNPA025DRE0	Transformer(for control unit)	1	AT

Note : The voltage supplied to the parts "" are greater than 250V.

★ Refer to "REPLACEMENT PARTS LIST" described at after PARTS LIST.

REF. NO.	PART NO.	DESCRIPTION	Q'TY	CODE
VRS1	RH-VZA009DRE0	Varistor 14DK471J	1	AE
3- 3	HPNLCA378WRJ0	Control panel frame	1	AT
3- 4	GMADIA031WRR0	Display filter	1	AH
3- 5	DUNTKA184WRE0	Key unit	1	AX
3- 6	LANGTA046WRW0	Key unit angle	1	AK
3- 7	LCHSMA022WRW0	Control panel back plate	1	AL
3- 8	XCTSD40P12000	Screw; Key unit angle and control panel back plate mtg.	4	AA
3- 9	XHPSD30P12XS0	Screw; cpu unit mtg.	6	AA
3-10	LX-BZ0198WRE0	Screw; relay unit mtg.	2	AA

OVEN PARTS

4- 1	FOVN-A090WRY0	Oven cavity	1	BR
4- 2	FROLPA008WRK0	Turntable roller stay	1	AR
4- 2A	NROLPA010WRE0	Turntable support roller	3	AE
4- 3	NCPL-A016WRF0	Turntable coupling	1	AF
4- 4	NTNT-A005WRHO	Turntable tray	1	AU
4- 5	PFILWA008WRP0	Lamp filter	1	AN
4- 6	PCOVPA050WRE0	Waveguide cover	1	AG
4- 7	PDUC-0300WRF0	Magnetron cooling duct(A)	1	AG
4- 8	PDUC-A144WRF0	Magnetron cooling duct(B)	1	AH
4- 9	PDUC-A196WRW0	Heater duct	1	AQ
4-10	FFANJ0034WRK0	Fan blade ass'y	1	AF
4-10A	LSTY-0030WRE0	Fan retainer clip	1	AA
4-11	LANGFA056WRW0	Chassis support	1	AF
4-12	LANGKA193WRF0	Upper latch hook	1	AF
4-13	MLEVF0124WRE0	Monitor switch lever	1	AF
4-14	LANGKA194WRF0	Lower latch hook	1	AG
4-15	MELVPA081WRF0	Stop switch lever	1	AC
4-16	LANGF0296WRP0	Oven support angle	1	AD
4-17	FDUC-A058WRW0	Steam duct	1	AQ
4-18	PCUSU0380WRP0	Steam duct cushion (C)	2	AA
4-19	PCUSUA083WRP0	Steam cushion	1	AA
4-20	FFANMA004WRK0	Convection fan ass'y	1	AT
4-21	FREFHA006WRK0	Thermal protection ass'y(left)	1	AN
4-22	PREFHA014WRW0	Thermal protection plate(right)	1	AP
4-23	PFPF-A018WRE0	Thermal protection sheet(left)	1	AH
4-24	PFPF-A019WRE0	Thermal protection sheet(right)	1	AG
4-25	NBRGPA001WRE0	Bearing	1	AF
4-26	PPACGA025WRF0	Bearing packing	1	AB
4-27	LANGTA121WRW0	Thermal protection plate (for convection motor)	1	AB
4-28	LBNDKA029WRE0	Heating element holder	2	AC
4-29	FANGTA056WRY0	Shaft mounting plate ass'y	1	AF
4-30	LANGQA068WRW0	Convection motor mounting plate	1	AE
4-31	PFTA-A009WRW0	Damper	1	AE
4-32	NSFTTA017WRM0	Damper shaft	1	AA
4-33	MCAMPA015WRF0	Damper cam	1	AC
4-34	FHNG-A045WRY0	Oven hinge(lower)	1	AG
4-35	MHNG-0123WRM0	Oven hinge(upper)	1	AE
4-36	PCOVPA018WRW0	Sensor cover	1	AE
4-37	PGIDHA009WRW0	Convection air guide (A)	1	AE
4-38	PGIDHA021WRW0	Convection air guide (B)	1	AG
4-39	PGIDHA011WRP0	Magnetron air guide	1	AD
4-40	PSKR-A067WRW0	Convection air guide (upper)(C)	1	AB
4-41	PSKR-A068WRW0	Convection air guide (inside)(D)	1	AB
4-42	PSKR-A069WRW0	Convection air guide (lower)(E)	1	AC
4-43	PSKR-A070WRW0	Air barrier (right)(F)	1	AE
4-44	PSKR-A079WRW0	Air barrier (right)(F)	1	AC
4-45	PSKR-A080WRW0	Convection air guide (H)	1	AB
4-46	PCUSUA083WRP0	Steam duct cushion	1	AA
4-47	PCUSUA082WRP0	Damper cushion	1	AA
4-48	PSPA-A021WRF0	Spacer	3	AC
4-49	PREFHA019WRW0	Thermal protection plate (bottom)	1	AM
4-50	PCUSUA085WRP0	Steam cushion (B)	1	AA
4-51	PCUSUA084WRP0	Air guide cushion	1	AA
4-52	PCUSG0078YBP0	Spacer cushion	3	AA
4-53	PFPF-A024WRE0	Thermal protection sheet (right A)	1	AC

Note : The voltage supplied to the parts "*" are greater than 250V.

★ Refer to "REPLACEMENT PARTS LIST" described at after PARTS LIST.

REF. NO.	PART NO.	DESCRIPTION	Q'TY	CODE
4-54	PFPF-A025WRE0	Thermal protection sheet (right B)	1	AC
4-55	PFPF-A026WRE0	Thermal protection sheet (bottom)	1	AK
4-56	PCUSU0326WRP0	Cushion	1	AB
4-57	PGISHA024WRE0	Heater insulator (A)	1	AG
4-58	PGISHA025WRE0	Heater insulator (B)	1	AG
4-59	PGISHA026WRE0	Round insulator (A)	2	AD
4-60	PGISHA027WRE0	Round insulator (B)	2	AD
4-61	LANGQA096WRP0	Oven lamp socket mounting plate	1	AC
4-62	PFPF-A040WRE0	Thermal protection sheet (C)	1	AE
4-63	LANGQ0255WRW0	Capacitor mounting bracket	1	AC
4-64	LBNDK0035WRP0	Capacitor holder	1	AB

DOOR PARTS

5	CDORFA238WRK0	Door assembly	1	BS
5- 1	FANGTA051WRY0	Latch plate	1	AG
5- 2	FLEVF0106WRY0	Joint lever	1	AD
5- 3	LSTPPA018WRFO	Upper latch head	1	AC
5- 4	LSTPPA019WRFO	Lower latch head	1	AC
5- 5	MSPRT0059WRE0	Latch spring	1	AC
5- 6	HDECQA075WRFO	Door sash right	1	AG
5- 7	HDECQA074WRFO	Door sash left	1	AF
5- 8	HDECQA072WRE0	Door sash upper	1	AM
5- 9	HDECQA073WRE0	Door sash lower	1	AM
5-10	DDORFA115WRY0	Door panel ass'y	1	BF
5-11	PGLSPA106WRE0	Door glass	1	AY
5-12	PPACG0105WRE0	Door packing	2	AA
5-13	GCOVHA104WRFO	Choke cover	1	AK
5-14	HDECQA076WRFO	Door handle	1	AH
5-15	HDECAA072WRE0	Door decolation plate left	1	AE

MISCELLANEOUS

6- 1	FAMI-A008WRE0	Low rack	1	AS
6- 2	FAMI-A009WRE0	High rack	1	AS
6- 3	QW-HZ0059WRE0	High voltage wire A (Trans-Capa.)	1	AD
6- 4	QW-QZ0114WRE0	High voltage wire B (Mag-Capa.)	1	AE
6- 5	FW-VZA396WRE0	Main wire harness	1	AV
6- 6	TSPCNA664WRR2	Name plate	1	AC
6- 7	FW-VZA398WRE0	Thermistor harness	1	AK
6- 8	LBNDQ0004CBE0	Wire holder (WH-1., "M")	1	AA
6- 9	LHLDWQ0004YBE0	Wire holder (purse look "L")	1	AA
6-10	QTANP0020YBE0	Connector	1	AA
6-11	TCAUH0114WRR0	Caution label	1	AC
6-13	TCADC0222WRR0	Cook book	1	BA
6-14	TINSEA295WRR0	Operation manual	1	AL
6-15	LHLDWQ0005YBE0	Wire holder (purse lock "LL")	1	AA

SCREW, NUTS, WASHERS AND PINS

7- 1	LX-CZ0050WRE0	Screw; door handle mtg.	3	AA
7- 2	LX-CZ0017WRE0	Screw; convection air guide (A), (B), (C), (D), (H) and thermistor mtg.	13	AA
7- 3	XCPSD40P06000	Screw; spacer mtg.	3	AA
7- 4	LX-CZ0043WRE0	Screw; shaft mounting plate, convection motor mounting plate, and thermal protection plate(left)mtg.	10	AA
7- 5	LX-NZ0081WRE0	Nut; convection motor mtg.	2	AA
7- 6	XCPWW30P12XW0	Screw; heating element holder mtg.	2	AA
7- 7	XBPSD30P14K00	Screw; damper switch mtg.	1	AA
7- 8	XCPSD30P06000	Screw; damper motor and AH sensor mtg.	3	AA
7- 9	LX-BZ0207WRE0	Screw; oven lamp socket mtg.	2	AA
7-10	LX-NZ0029YBE0	Nut; steam duct ass'y and thermal protection plate(right)mtg.	6	AA
7-11	XBTSD40P08000	Screw; steam duct ass'y mtg	2	AA
7-12	XBTUW40P06000	Screw; waveguide cover mtg.	3	AA
7-13	XBTUW40P08000	Screw; thermal protection plate(right),	17	AA

Note: The voltage supplied to the parts "*" are greater than 250V.

★ Refer to "REPLACEMENT PARTS LIST" described at after PARTS LIST.

REF. NO.	PART NO.	DESCRIPTION	Q'TY	CODE
7-14	XCP40P08000	steamduct ass'y, heating element unit and heating element mtg. Screw; thermal protection plate(bottom), convection air guide(right), ven support angle, AH sensor cover mtg.	11	AA
7-15	XCTSD40P12000	Screw; base cabinet mtg.	3	AA
7-16	LX-BZ0141WRE0	Screw; monitor switch lever mtg.	1	AA
7-17	XBPSD40P25000	Screw; cooling fan motor mtg.	2	AA
7-18	XWHTZ30-05081	Washer; convection fan ass'y mtg.	1	AA
7-19	XFPSD40P08000	Screw; turntable motor mtg.	2	AA
7-20	XCTWW40P10000	Screw; waveguide cover mtg.	3	AA
7-21	LX-BZ0186WRE0	Screw; High voltage capacitor holder mtg. Base cabinet, monitor resistor, High voltage capacitor ass'y, turntable motor cover mtg.	13	AA
7-22	XCTSD40P08000	Screw; magnetron air guide	1	AA
7-23	LX-CZ0052WRE0	Screw; rear cabinet, upper and lower latch hook mtg	6	AA
7-24	LX-CZ0063WRE0	Screw; magnetron cooling duct (B)mtg	1	AA
7-25	XREUW30-06000	Ring; convection motor mtg	1	AA
7-26	XCP40P10000	Screw; oven lamp socket mounting plate mtg.	2	AA
7-27	XBPSD50P12K00	Screw; magnetron mtg.	4	AA
7-28	LX-CZA020WRE0	Screw; upper and lower oven hinge mtg.	6	AA
7-29	LX-BZA036WRE0	Screw; cabinet mtg.	8	AA
7-30	XWHSD50-08000	Washer; monitor switch lever mtg.	1	AA
7-31	XNESD40-32000	Nut; cooling fan motor mtg.	2	AA
7-32	XBPSD60P14KSO	Screw; power transformer mtg	2	AA
7-33	XWVSD60-07000	Washer; power transformer mtg.	1	AA
7-34	LX-BZA055WRE0	Screw; cabinet mtg.	2	AA
7-35	XHSSB40P08000	Screw; oven lamp access cover ass'y mtg.	1	AA
7-36	XCTSD40P12000	Screw; cord holder mtg.	1	AA
7-37	XCP40P27000	Screw; cord anchorage mtg.	2	AA
7-38	XBTUW40P12000	Screw; convection heater mtg.	2	AA

HOW TO ORDER REPLACEMENT PARTS

To have your order filled promptly and correctly, please furnish the following information.

1. MODEL NUMBER
2. REF. NO.
3. PART NO.
4. DESCRIPTION

(RDP1303U)

REPLACEMENT PARTS LIST

This replacement parts list shows interchangeability of marked (★) parts on the control panel parts to the alterations of product locations.

This list has been prepared to show LISTED PART NO. along with the USED PART NO. side by side.

(RDQ1101U)

REF. NO.	LISTED PART NO.	USED PART NO.	REF. NO.	LISTED PART NO.	USED PART NO.
C4	RC- EZA061DRE0	RC- EZT475AF1E	C10	RC- EZA058DRE0	RC- EZT226AF1E
C5 etc.	RC- KZA004DRE0	VCKYAT1EX153N	C30	RC- EZA060DRE0	RC- EZT476AF1C
C6	RC- EZA059DRE0	RC- EZT106AF1E	C50	RC- KZ104QDRE0	VCTYPG1EF104Z
C9	RC- EZA057DRE0	RC- EZT107AF1C	C80	RC- EZA063DRE0	RC- EZT474AF1H
			C81	RC- EZA062DRE0	RC- EZT335AF1H

NOTE :

Common resistors have been omitted from this parts list, such as 1/4W and 1/2W carbon resistors below is a compatibility list and cross reference information.

	PART CODE LISTED	PART CODE COMPATIBLE	DESCRIPTION
A	RR-DZ103NDRE0 : : : :	VRD-ST2DF103J : : : :	1/4W 10k Ω small shape carbon film
B	RR-DZ102DDRE0 : : : :	VRD-ST2EF102J : : : :	1/4W 1.0k Ω carbon film.
C	RR-DZ101PDRE0 ↓ ↓ 1 2	VRD-ST2HA101J ↓ ↓ 3 4	1/2W 100 Ω carbon film.

PART CODE LISTED

- *1.D : Carbon film resistor.
- *2.N : 1/4W and small shape.
D : 1/4W.
P : 1/2W.
- *3.D : Carbon film resistor.
- *4.D : 1/4W and small shape.
E : 1/4W.
H : 1/2W.

(RDQ1102U)

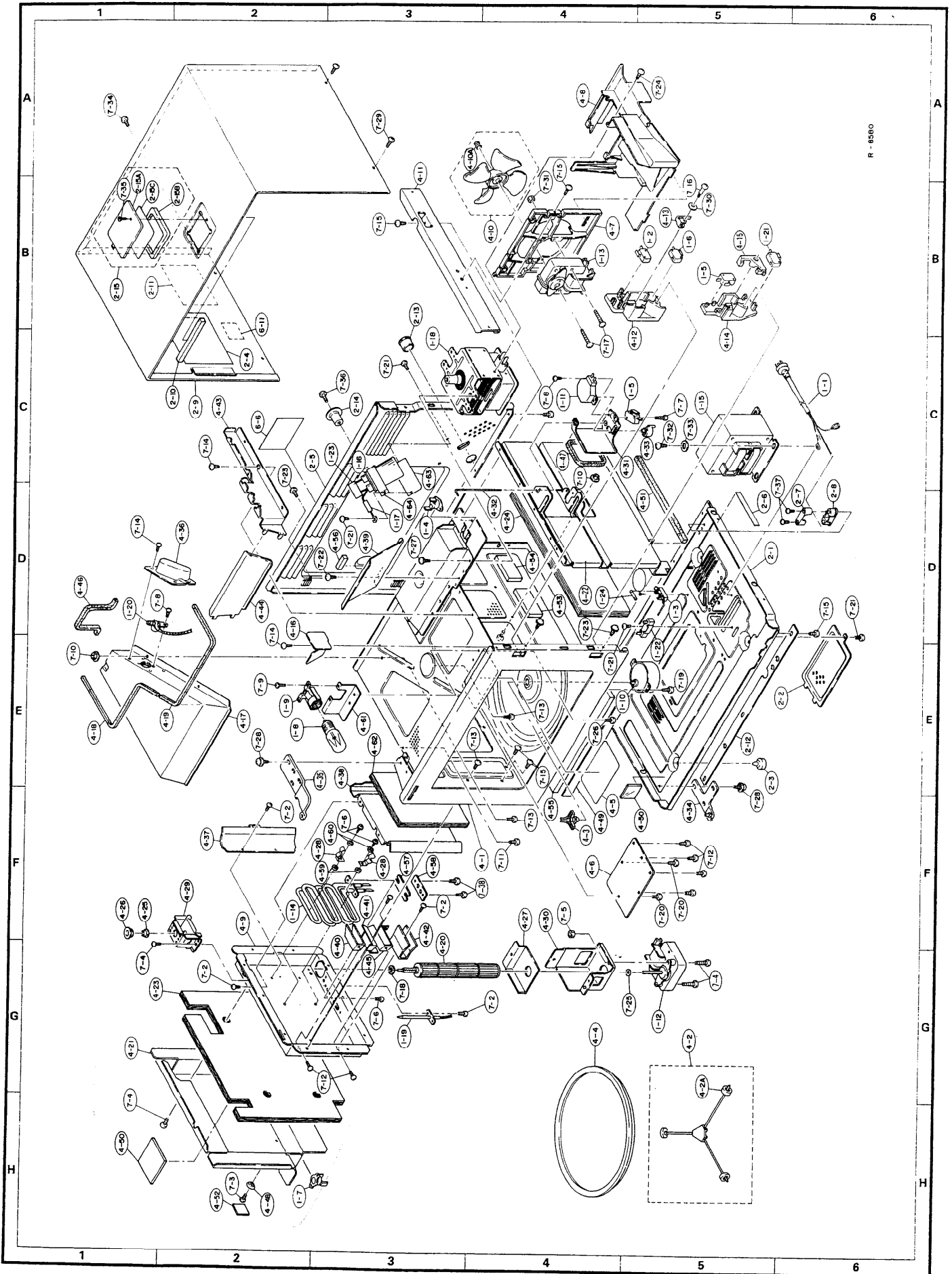

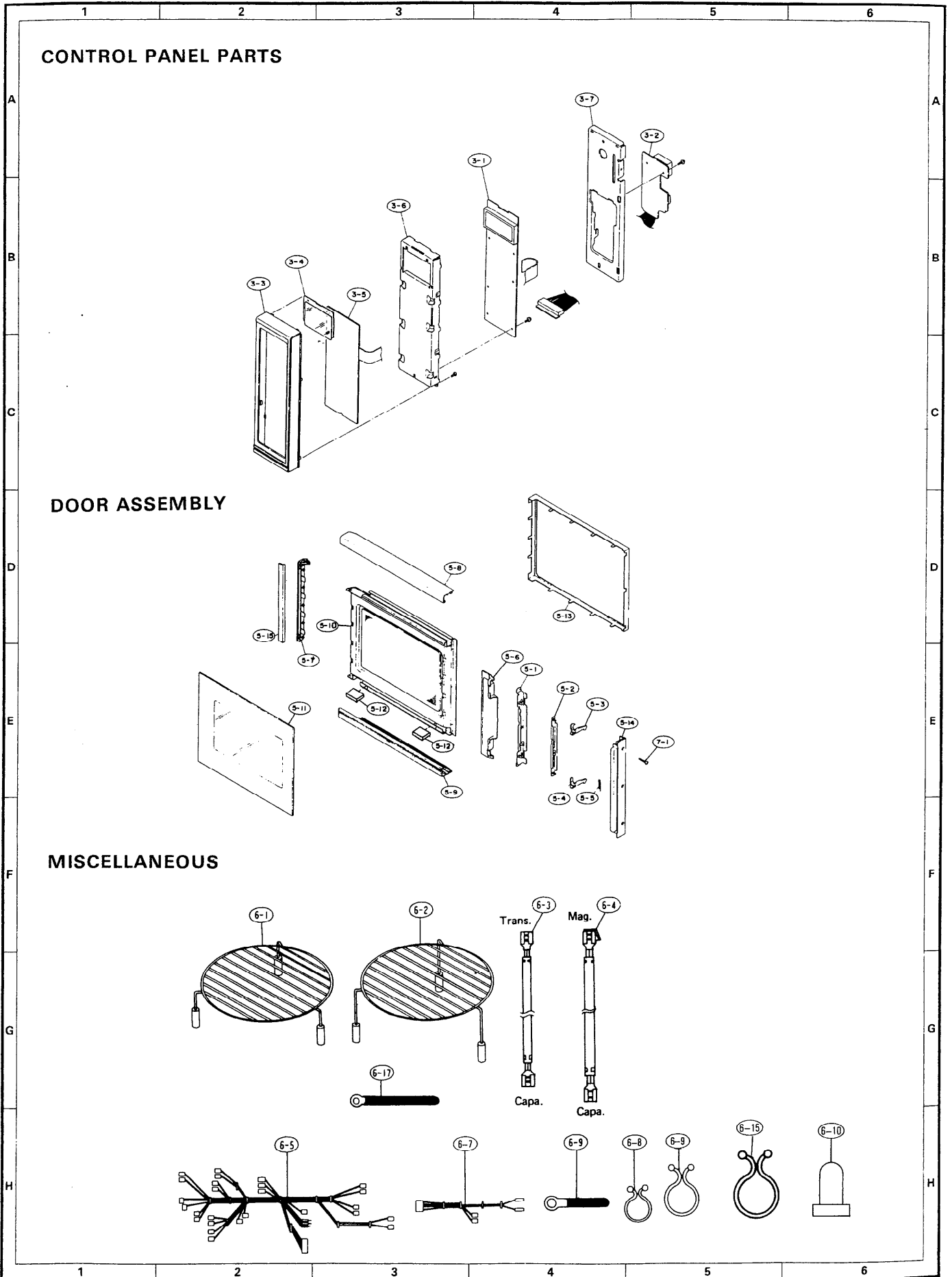

PACKING AND ACCESSORIES

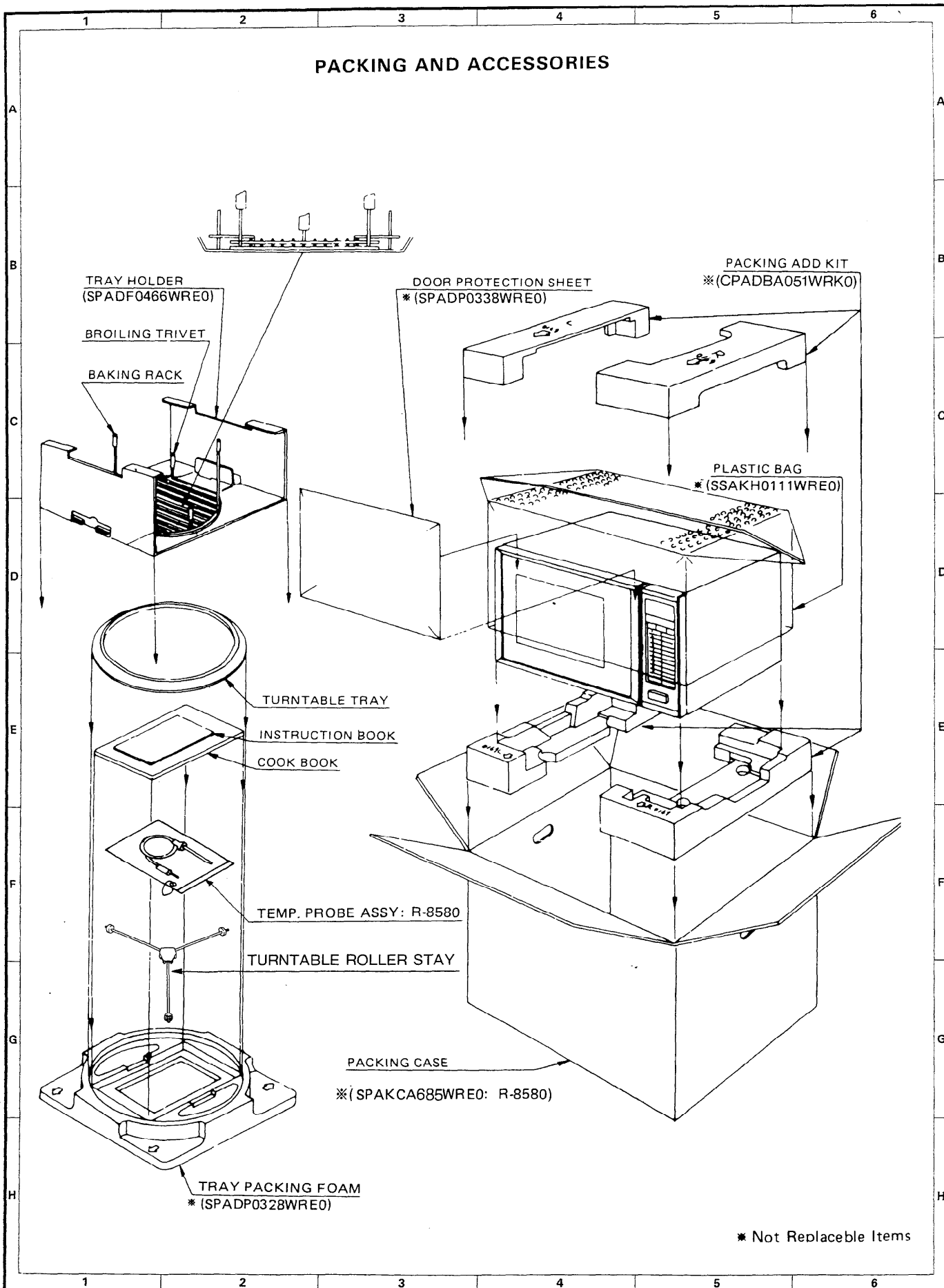



SHARP