

SHARP®

POS TERMINAL

MODEL

UP-600

INSTRUCTION MANUAL

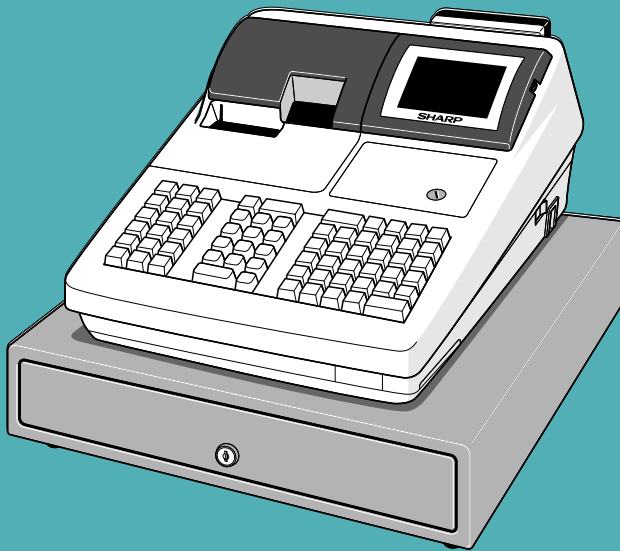

WARNING

FCC Regulations state that any unauthorized changes or modifications to this equipment not expressly approved by the manufacturer could void the user's authority to operate this equipment.

Note: This equipment has been tested and found to comply with the limits for a Class A digital device, pursuant to Part 15 of the FCC Rules. These limits are designed to provide reasonable protection against harmful interference when the equipment is operated in a commercial environment.

This equipment generates, uses, and can radiate radio frequency energy and, if not installed and used in accordance with the instruction manual, may cause harmful interference to radio communications. Operation of this equipment in a residential area is likely to cause harmful interference, in which case the user will be required to correct the interference at his own expense.

CAUTION

The socket-outlet should be installed near the equipment and should be easily accessible.

FOR YOUR RECORDS

Please record below the model number and serial number for easy reference in case of loss or theft. These numbers are located on the right side of the unit. Space is provided for further pertinent data.

Model Number _____

Serial Number _____

Date of Purchase _____

Place of Purchase _____

INTRODUCTION

Thank you very much for your purchase of the SHARP POS Terminal Model UP-600. Please read this Manual carefully before operating your machine in order to gain full understanding of functions and features. Please keep this manual for future reference. It will help you if you encounter any operational problems.

IMPORTANT

- **Install your POS terminal in a location that is not subject to direct sunlight, unusual temperature changes, high humidity or exposure to water sources and keep away from heat and magnetic sources.**
Installation in such locations could cause damage to the cabinet and the electrical components.
- **The POS terminal should not be operated by an individual with wet hands.**
The water could seep into the interior of the POS terminal and cause component failure.
- **Do not apply excessive pressure to the display.**
Do not use a sharp-pointed object on the display, or the LCD may become damaged.
- **When cleaning your POS terminal, use a dry, soft cloth. Never use solvents, such as benzine and/or thinner.**
The use of such chemicals will lead to discoloration or deterioration of the cabinet.
- **The POS terminal plugs into any standard wall outlet (120V ±10% AC) with a dedicated earth-ground.**
Other electrical devices on the same electrical circuit could cause the POS terminal to malfunction.
- **If the POS terminal malfunctions, call your authorized SHARP dealer for service - do not try to repair the POS terminal yourself.**
- **For a complete electrical disconnection, remove the AC power cord from the wall outlet.**

PRECAUTION

This POS terminal has a built-in memory protection circuit which is operated by a rechargeable battery pack. It should be known that all batteries will, in time, dissipate their charge even if not used. Therefore to insure an adequate initial charge in the protection circuit and to prevent any possible loss of memory upon installation, it is recommended that each unit be allowed to be charged for a period of 24 to 48 hours prior to use by the customer.

In order to charge the battery pack, the machine must be plugged in and its power switch must be set to the "ON" position. This charging precaution can prevent unnecessary initial service calls.

BATTERY DISPOSAL

Contains Nickel Metal Hydride Battery. Must be Disposed of Properly.

Contact Local Environmental Officials for Disposal Instructions.

CONTENTS

INTRODUCTION	1
IMPORTANT	1
PRECAUTION	1
1. Part Names and Functions	8
External View	8
Front view	8
Rear view	8
Printer	9
Keyboard	10
Standard keyboard layout	10
Optional keys	11
Keys and Switches	13
Mode switch and mode keys	13
Drawer lock key	13
Printer cover lock key	13
Display	14
Operator display	14
Customer display	15
Screen save mode	15
2. Before Operating the POS Terminal	16
Display Adjustment	16
3. Time Display and Automatic Updating of the Date	17
4. Prior to Entries	18
Preparations for Entries	18
Error Warning	18
Sample Receipt	18
5. Entries	19
Server Code Entries	19
Item Selection from the Function Menu Windows	19
Item Entries	22
Single item entries	22
Repeat entries	23
Multiplication entries	24
Split-pricing entries	25
Successive multiplication entries	26
Scale entries	27
Single item cash sale (SICS) entries	29
Age verification (Birthday entry)	29
Link PLU/UPC entries	29
Mix-and-match function	30
Combo meal entries	30
Condiment entries (for PLU)	31
Repeat round entries	31
Price inquiry (view) function (for PLU/UPC)	32
UPC learning function	32
Price change function (for UPCs)	33
PLU level shift (for direct PLUs)	34
PLU/UPC price level shift	35
Display of Subtotals	36
Merchandise subtotal	36

Taxable subtotal	36
Including-tax subtotal	36
Tray subtotal	36
Eat-in subtotal	36
Food stamp-eligible subtotal	36
Group discountable subtotal	37
Gasoline discount subtotal	37
Finalization of Transaction	38
Cash or check tendering	38
Mixed tendering (check + cash)	38
Cash or check sale that does not need any tender entry	38
Charge (credit) sale	38
Mixed-tender sale (cash or check tendering + charge tendering)	38
Food stamp tendering	39
Food stamp status shift	39
Tax Calculations	40
Automatic tax	40
Manual tax	40
Tax deletion	40
Tax status shift	40
Guest Check (GLU/PBLU)	41
GLU/PBLU system	41
Deposit entries	43
Transferring guest checks out or in (Transfer-out/in)	43
Bill totalizing/bill transfer	44
Bill separating	45
Bill printing	45
Auxiliary Entries	46
Percent calculations (premium or discount)	46
Discount entries	46
Refund entries	46
Return entries	46
Printing of non-add code numbers	46
Refund sales mode	47
Group discount entries	47
Remote printer send function	48
Gratuity	48
Payment Treatment	48
Tip-in entries	48
Tip editing	49
Tip paid entries	49
Currency conversion	49
Received-on-account entries	50
Paid-out entries	50
No-sale (exchange)	51
Cashing a check	51
Customer management	52
WASTE mode	53
6. Correction	54
Correction of the Last Entry (Direct Void)	54
Correction of the Next-to-Last or Earlier Entries (Indirect Void)	55
Subtotal Void	56
Correction of Incorrect Entries Not Handled by the Direct or Indirect Void Function	56
7. Special Printing Functions	57
Printing Message Text for Remote Printer or Chit Receipts	57
Copy Receipt Printing	57
Validation Printing Function	58

Validation slip setting and printing	58
Validation printing examples	59
Validation slip specification	61
Server Arrival/Departure Time Printing	61
8. Manager Mode	62
Override Entries	62
9. Correction after Finalizing a Transaction	63
10. Reading (X) and Resetting (Z) of Sales Totals	64
How to take a X1/Z1 or X2/Z2 reports	64
Flash report	64
Daily Sales Totals	67
Transaction report	67
Department report	70
Individual group total report on departments	71
Full group total report on departments	71
Department markdown report	71
PLU/UPC report by designated range	72
PLU/UPC pick up report	73
PLU/UPC report by associated department	74
Individual group total report on PLUs/UPCs	75
Full group total report on PLUs/UPCs	75
PLU/UPC stock report by designated range	75
PLU/UPC stock pick up report	75
PLU/UPC zero sales report (full)	76
PLU/UPC zero sales (by dept.) report	76
PLU/UPC minimum stock report	76
PLU/UPC price category report	77
Cash in drawer report	77
Positive check report	77
Dynamic UPC report by designated range	78
Dynamic UPC pick up report	78
Dynamic UPC report by associated department	79
Tax report	80
Key capture report	80
Individual server report	81
Full server report	82
Hourly report	83
GLU/PBLU report	84
GLU/PBLU report by server	84
Closed GLU/PBLU report	85
Closed GLU/PBLU report by server	86
X1/Z1 stacked reports	86
Periodic Consolidation	87
Transaction report	87
Daily net report	88
Customer sales report 1 and 2	89
Customer sales report by sales range	90
Customer charge account report	90
X2/Z2 stacked report	90
11. Non-accessed UPC and Customer Deletion	91
Non-accessed UPC report	92
Non-accessed customer report	92
Customer delete report	93
Dynamic UPC clear	93

12. How to Use the Programming Keyboard	94
Programming Keyboard Layout	94
How to Program Alphanumeric Characters	95
Using character keys on the keyboard	95
Entering character codes	96
13. Programming	97
Basic Instructions	97
Programming example	97
Article Programming	99
Department	100
PLU/UPC	102
Dynamic UPC	105
PLU range	105
PLU/UPC stock	106
Link PLU table (for PLU/UPC)	107
Condiment table	108
Mix & Match table	109
Combo meal table	110
Scale table	111
UPC Non-PLU code format	112
UPC delete	113
Direct Key Programming	114
Direct PLU/COMBO/Dept. key	114
PLU Menu Key Programming	116
PLU menu key	116
Functional Programming	117
Discount key (⊖ ₁ thru ⊖ ₅)	118
Percent key (% ₁ thru % ₅)	119
Group discount key (GDSC _{%1} thru GDSC _{%3})	120
Gas discount	121
Gratuity	122
Tip	122
RA	123
PO	124
Manual tax	124
Tax delete	125
No-sale	125
Void	126
Refund	126
Media Key Programming	127
Cash keys	128
Check keys	132
Charge keys	136
Food stamp tender key	140
Currency conversion keys	142
Eat-in keys	142
Service key	143
Final key	145
Cash in drawer	147
Check change	147
Check cashing	148
Text Programming	150
Function text	151
Department group text	153
PLU group text	153
Server group text	154
Message text	154
Personnel Programming	155
Server	155

Terminal Programming	156
Machine number	157
Consecutive number	157
Interval timer	157
Default menu level	158
Available GLU code	158
Bill number	158
Date/Time Setting	159
Date/time	159
Optional Feature Selection	160
Function prohibition	161
Function selection 1	163
Function selection 2	164
Printing selection	165
Secret Code Programming	166
Z1 reports	167
PGM2-mode operations	167
System Z1 reports	168
System PGM2-mode operations	168
Initial down-loading (with clearing of memory)	169
Maintenance down-loading (without clearing of memory)	169
Report Programming	170
Zero skip	171
Hourly report	171
Stacked report	172
Logo Text Programming	175
Receipt logo	176
Validation printing text	176
Bill logo	177
Device Configuration Programming	178
R/J printer (Built-in printer)	179
Bill (slip) printer	179
Report printer	180
Validation printer	180
Remote printer (KP#1 thru KP#9)	181
BCR (SCANNER)	182
GLU Code Programming	183
Customer Programming	184
Customer code	185
Customer programming	185
Negative Code File Programming	186
Negative code/Override status	186
Positive Code File Programming	187
Positive code	187
Macro Key Programming	188
Mode position/Auto key no.	188
Function Menu Key Programming	189
Function menu key	189
Capture Key Programming	190
Capture key data	190
Key Data Entry Job Table Programming	191
Capture job number	191
Tax Programming	192
Table tax	193
Rate (%) tax	195
Doughnut tax exempt (for the Canadian tax system)	195
TRAINING Mode Selection	196
TRAINING mode	196
Backup Data Send Programming	197
Backup data send	197

Backup Data Receive Programming	198
Backup data receive	198
PLU Updating (in the PGM1 Mode)	199
Automatic Sequencing Key Programming	200
Loading Dynamic UPC to the Main UPC File	201
Reading of Stored Programs	202
Program reading sequence	202
Sample printouts	203
Data Clear	215
14. Universal Product Code (UPC) or European Article Number (EAN)	216
UPC or EAN code	216
Add-on code	217
UPC file	217
15. Operator Maintenance	218
In Case of Power Failure	218
In Case of Printer Error	218
Paper roll near-end sensing function (only for the journal paper) <option>	218
Installing and Removing the Paper Roll	219
Recording paper specifications	219
Installing the paper roll	220
Removing the paper roll	221
Removing the paper jam	222
Installing the ink ribbon cassette	223
Removing the Till and the Drawer	224
Operating the Drawer by Hand	224
Before Calling for Service	225
16. Options	225
List of Options	225
17. Specifications	226

1

Part Names and Functions

This chapter describes the part names and functions of this POS terminal.

External View

■ Front view

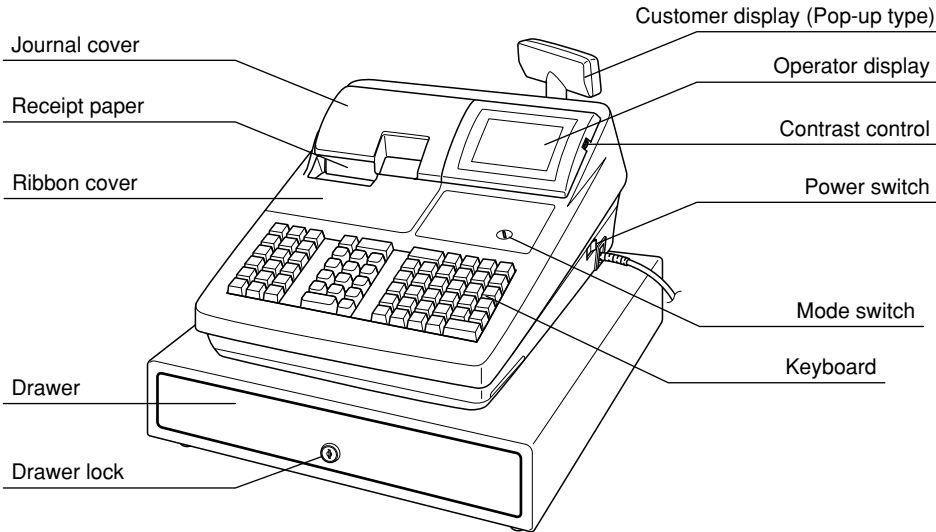

■ Rear view

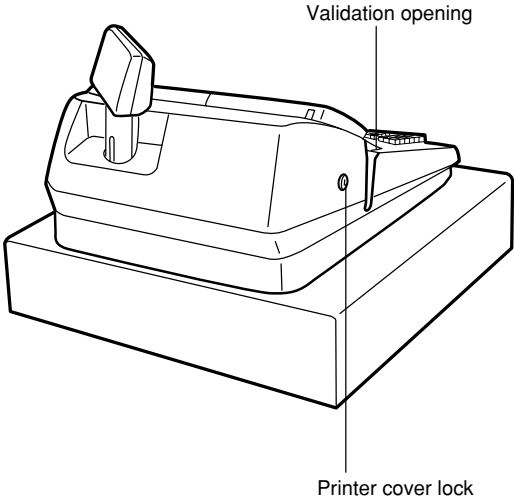

Printer

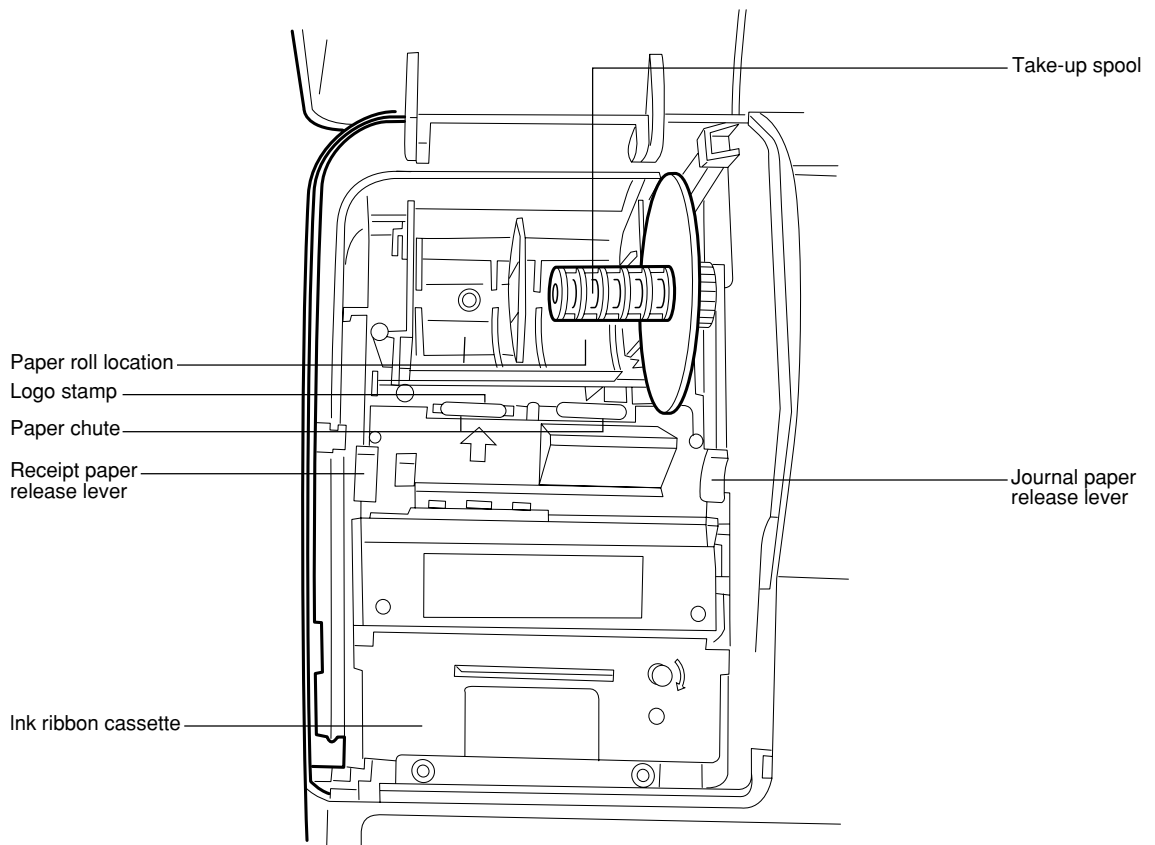

- **Paper release lever**

Used to load or unload the machine with paper roll (receipt and journal paper). Keep the lever down to take in or out the paper roll.

NOTE

































Do not attempt to take in or out the paper roll without pressing this lever. This may result in damage to the printer.

Keyboard

Standard keyboard layout

RECEIPT	JOURNAL	RCPT	CASH #	PLU/UPC	PRICE CHANGE	AMT	INQ	FS SHIFT	AUTO 1		
MISC FUNC	CANCEL	PAGE UP	@/FOR	•	CL	5	10	15	20	FS TEND	AUTO 2
CONV #	↑	PAGE DOWN	7	8	9	4	9	14	19	NS	NEXT \$
←	↓	→	4	5	6	3	8	13	18	CHK #	CH #
TAX	TAX SHIFT	ENTER	1	2	3	2	7	12	17	MDSE SBTL	SBTL
RFND	VOID	#/TM	0	00	1	6	11	16	CA/AT		

NOTE All the keys but the receipt paper feed and journal paper feed keys can be re-positioned. If you want to change the layout, contact your authorized SHARP dealer.

	Receipt paper feed key		Tax 1 shift key
	Journal paper feed key		Manual tax key
 ~ 	} Numeric keys		Merchandise subtotal key
		 ~ 	Department key
	Decimal point key		Miscellaneous function menu key
	Clear key		Enter key
	Multiplication key	 	Automatic sequencing 1 and 2 keys
	Refund key		Food stamp shift key
	Void key		Food stamp tender key
	Amount entry key		Charge menu key
	Server code entry key		Currency conversion menu key
	PLU/UPC key		Check menu key
	UPC inquiry key		Subtotal key
	UPC price change key		Cash/amount tendered key
	No-sale key		Next higher dollar key

	Receipt print key			} Cursor (right/left/up/down arrow) keys
	Page up/down keys			
	Non-add code/Date & time display key		Cancel key	

NOTE

The following optional keys can optionally be mounted in place of those shown in the figure of the standard keyboard layout. For details, please consult your authorized SHARP dealer.

Optional keys

	Dept. number key			Check 1 thru 5 keys
				Transfer out key
				Transfer in key
				Cash tip key
				Charge tip key
				Tip paid key
				Eat in 1 thru 3 keys
				Tax 2 thru 4 shift keys
				Deposit key
				Deposit refund key
				PLU level shift menu key
	Backspace key			Remote printer send key
	Delete key			Gratuity exempt key
	Service key			Tare entry key
	Final key			Balance key
	Tray subtotal key			Repeat entry key
	Return key			Individual payment key

GAS SBTL	Gasoline sales subtotal key	CUST	Customer code entry key
GLU	Guest lookup key	BIRTH	Birthday entry key
P-SHIFT #	Price shift menu key	TABLE #	Table no. (seat no.) entry key
SCALE	Scale entry key	VOID MENU	Void menu key
LEVEL 1 ~ LEVEL 5	PLU level shift 1 thru 5 keys	RFND SALE	Refund sale key
P1 ~ P6	Price level shift 1 thru 6 keys	RCP SW	Receipt ON/OFF key
GD1 SHIFT ~ GD3 SHIFT	Group discount shift 1 thru 3 keys	WASTE	Waste mode key
PRINT	Validation print key	C NEXT	Condiment next key
BILL	Bill print key	EDIT TIP	Edit tip key
PAST VOID	Past void key	RP ROUND	Repeat round key
SBTL VOID	Subtotal void key	GLU RECALL	Table# recall key
GDSC %1 ~ GDSC %3	Group discount %1 thru 3 keys	MSG 1 ~ MSG 5	Message 1 thru 5 keys
COVER CNT	Cover count entry key	MSG MENU	Message menu key
NC	New check key	PLU MENU1 ~ PLU MENU50	PLU menu 1 thru 50 keys
BS	Bill separation key	MACRO 1 ~ MACRO 4	Macro 1 thru 4 keys
BT	Bill totalize/Bill transfer key (CHECK-ADD)	UPSIZE	Upsize key
CASH MENU	Cash menu key	CAP.1 ~ CAP.10	Data capture 1 thru 10 keys
FUNC. MENU	Function menu key		

Keys and Switches

■ Mode switch and mode keys

The mode switch can be operated by inserting one of the three supplied mode keys - manager (MA), submanager (SM), and operator (OP) keys. These keys can be inserted or removed only when the switch is in the “REG” or “OFF” position.

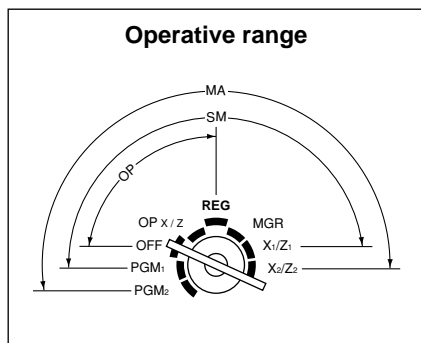

• Manager key (MA)

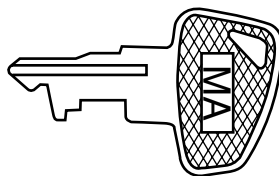

• Submanager key (SM)

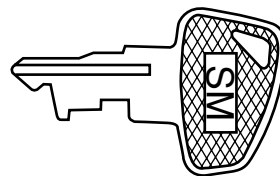

• Operator key (OP)

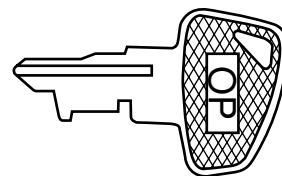

The mode switch has these settings:

OFF: This mode locks all register operations. No change occurs to existing data.

OP X/Z: This setting allows cashiers/servers to take X or Z reports for their sales information. (This setting may be used only when your register has been programmed for “OP X/Z mode available” in the PGM2 mode.)

REG: For entering sales

PGM1: To program those items that need to be changed often: e.g., unit prices of departments, PLUs or UPCs, and percentages

PGM2: To program all PGM1 items and those items that do not require frequent changes: e.g., date time.

MGR: For manager's and submanager's entries

The manager can use this mode to make entries that are not permitted to be made by cashiers/servers - for example, after-transaction voiding and override entries.

X1/Z1: To take the X/Z report for various daily totals

X2/Z2: To take the X/Z report for various periodic (weekly or monthly) consolidation of totals.

■ Drawer lock key

This key locks and unlocks the drawer. To lock it, turn 90 degrees counterclockwise. To unlock it, turn 90 degrees clockwise.

This same key is also used to open the cash drawer.

(Please refer to “15. Operator Maintenance — Operating the Drawer by Hand”.)

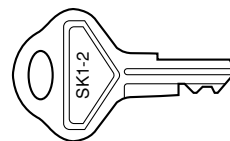

■ Printer cover lock key

This key locks and unlocks the printer cover. To lock it, turn 90 degrees counterclockwise. To unlock, turn 90 degrees clockwise.

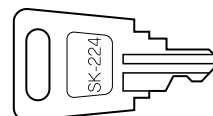

Display

■ Operator display

- Screen example 1 (REG mode)

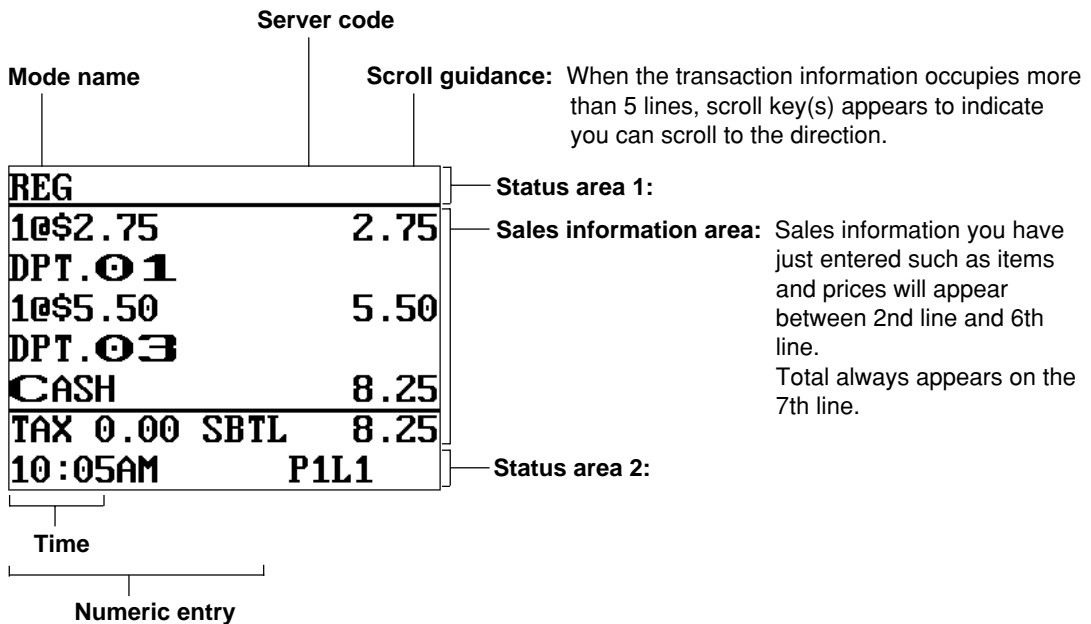

Price level shift indicator (P1-P6)

: Shows the PLU/UPC price level currently selected.

PLU level shift indicator (L1-L5)

: Shows the PLU level currently selected.

Receipt shift indicator (r)

: Shows the receipt shift status.

T-Log near full indicator (■)

: Appears (○) when the used memory is 80%.
 : Appears (◐) when the used memory is 90%.
 : Appears (◑) when the used memory is 95%.

Stock alarm indicator (!)

: Appears when the stock of the PLU which you entered is zero, negative or reaches the minimum stock.

Receipt ON/OFF status indicator (R)

: Appears when the receipt ON-OFF function signs OFF.

Sentinel mark (X)

: Appears in the lower right corner of the screen when the cash in drawer exceeds a programmed sentinel amount. The sentinel check is performed for the total cash in drawer.

• Screen example 2 (PGM mode)

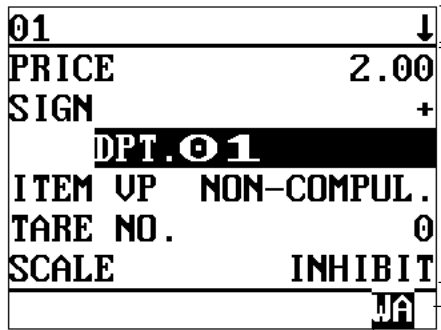

Programming item information area

Programming area:
Programmable items are listed.

Caps lock indicator (A/a):

The upper-case letter "A" appears when caps lock is on, and the lower-case letter "a" appears when the caps lock is off during text programming.

Double-size character mode indicator (W):

Appears when the double-size character mode is selected during text programming.

■ Customer display (Pop-up type)



■ Screen save mode

When you want to save the electrical power or the display's life, your POS terminal is provided with the screen save function. This function can turn the LCD backlight off when servers do not operate the POS terminal for an extended period of time. You can program the time for which your POS terminal should keep the normal status (in which the backlight is "ON") before it goes into the screen save mode. To exit the screen save mode, press any key.

2

Before Operating the POS Terminal

This chapter describes those steps required prior to using the POS terminal for the first time.

Display Adjustment (operator display)

You can adjust the contrast of the display by using the contrast control. To further the operator's view, the display may be tilted forward using the LCD display tilt tab.

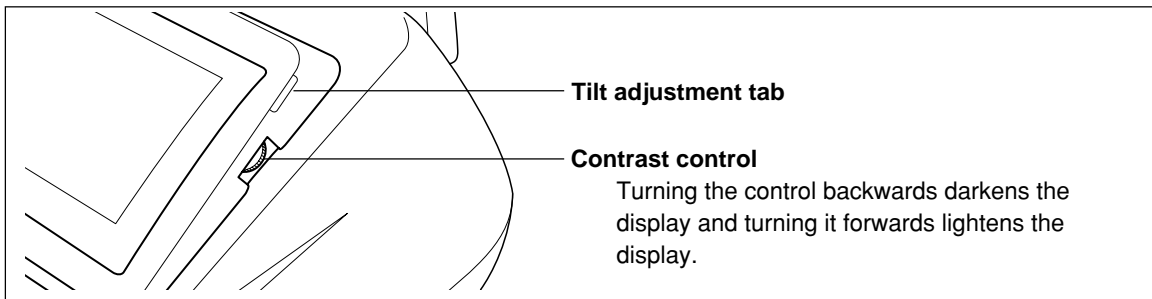

The backlight in the display is a consumable part. When the LCD display may no longer be adjusted and becomes darker, you should change the backlight. Consult your authorized SHARP dealer for further details.

3

Time Display and Automatic Updating of the Date

Time display

When you need the time displayed, press the **[#/TM]** key while the POS terminal is in the REG or MGR mode. The time display disappears as soon as you press the **[CL]** key in the REG or MGR mode or begin a subsequent entry.

The screenshot shows a POS terminal display with the following text:

REG	0001
08/26/2002	
10:43AM	
TAX 0.00	SBTL 0.00
10:43AM	P1L1

Annotations:

- A bracket groups "08/26/2002" (labeled "Date") and "10:43AM" (labeled "Time") with the text: "This display appears by pressing the **[#/TM]** key."
- A line points from "10:43AM" in the bottom row to the text: "Time (This display is held, even if the **[CL]** key is pressed.)"

Automatic updating of the date

Once the internal clock unit is started at the desired time, it continues to run as long as the battery pack is charged and will also update the date based on the calendar year.

4

Prior to Entries

REG MODE

Preparations for Entries

■ Receipt and journal paper rolls

If the receipt and journal paper rolls are not set in the machine or the existing rolls are low in supply, install new ones according to section “Installing and Removing the Paper Roll” under “Operator Maintenance.”

■ Receipt ON/OFF function

You can disable receipt printing in the REG mode to save paper using the receipt function. To disable receipt printing, press the **MISC FUNC** key and select RCP S.W. from the menu and turn the receipt OFF by press the **◦** key. When the function is in the OFF status, the receipt off indicator “R” is highlighted.

NOTE Your register will print reports regardless of the receipt state. This means that the receipt roll should be installed even when the receipt state is “OFF”.

Error Warning

In the following examples, your POS terminal will go into an error state accompanied with a warning beep and the error message on the display. Clear the error state by pressing the **CL** key and take the proper action to remedy the problem.

- When you exceed a 32-digit number (entry limit overflow):
Cancel the entry and re-enter a correct number.
- When you make an error in key operation:
Clear the error and try the entry again.
- When you make an entry beyond a programmed amount entry limit:
Check to see if the entered amount is correct. If it is correct, it may be possible to enter it in the MGR mode. Please contact your manager.
- When an including-tax subtotal exceeds eight digits:
Clear the error display by pressing the **CL** key and press a media key to finalize the transaction.

Sample Receipt

The print format will vary depending on the printer you use.

	SHARP PRESENTS THE UP-600 SHARP IS THE BEST		
Date	08/27/2002	10:24AM	Time
Machine no.	123456#2013	JACK0001	Server name/server code
Consecutive no.			
Item entry	PLO0007-1	\$8.73	
	MDSE ST	\$8.73	
	TAX1	\$0.53	
	***TOTAL	\$17.99	Sales total
	CASH	\$10.00	Cash amount tendered
	CHANGE	\$0.74	Change due

Server Code Entries

Prior to an item entry, the server will be compelled to enter his or her assigned server code. However, this may not be necessary when the POS terminal has been programmed for “stay-down server mode.”

Procedure

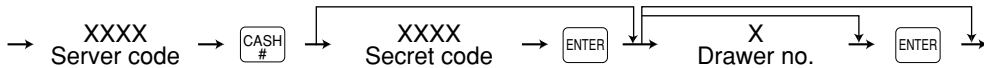

NOTE

- When the server entry system is programmed for “stay-down server mode,” no other server can sign on unless the server who has signed on is signed off.
- When the server entry system is programmed for “automatic server sign-off mode,” a server must sign on prior to each sales transaction.

The sign-off operation can be performed by using the following procedure in the REG or MGR mode.

To sign off a server: → CASH #

- Depending upon how your POS terminal has been preset, if the item entry is made when the server is signed off, the server entry will be prompted on the window and the server entry will be compelled.

REG	
SERVER NOT ASSIGNED	
TAX 0.00	SBTL 0.00
P1L1	

Item Selection from the Function Menu Windows

Your POS terminal allows you to select functions from specified function menu windows depending upon the terminal set up. For example, if you want to finalize a check 1 sale, select the option “CHECK1” from the “CHK.MN” Menu instead of pressing the **CHK 1** key.

Each menu can be opened as follows:

• Miscellaneous function menu window

MISC FUNC	→	M.FUNC	↓
01	RCP S.W.		
02	***RA		
03	***RA2		
04	***PO		
05	***PO2		
TAX 0.00		SBTL	0.00
			P1L1

• Check menu window

CHK #	→	CHK.MN	
1	CHECK1		
2	CHECK2		
3	CHECK3		
4	CHECK4		
5	CHECK5		
TAX 0.00		SBTL	1.50
			P1L1

• Cash menu window

CASH MENU	→	CA.MN	
1	CASH		
2	CASH2		
3	CASH3		
4	CASH4		
5	CASH5		
TAX 0.00		SBTL	1.50
			P1L1

• Void menu window

VOID MENU	→	UD.MN	
1	DIR UD		
2	PAST UD		
3	SBTL UD		
TAX 0.00		SBTL	1.50
			P1L1

• Message menu window

MSG MENU	→	REG	0001
1	MESSAGE 1		
2	MESSAGE 2		
3	MESSAGE 3		
4	MESSAGE 4		
5	MESSAGE 5		
TAX 0.00		SBTL	1.50
			P1L1

• Charge menu window

CH #	→	CHG.MN	↓
1	CHARGE1		
2	CHARGE2		
3	CHARGE3		
4	CHARGE4		
5	CHARGE5		
TAX 0.00		SBTL	1.50
			P1L1

• Conversion menu window

CONV #	→	CNU.MN	
1	CONV 1		
2	CONV 2		
3	CONV 3		
4	CONV 4		
TAX 0.00		SBTL	1.50
			P1L1

• Function menu window

FUNC MENU	→	FNC.MN	↓
01	%1		
02	%2		
03	%3		
04	%4		
05	%5		
TAX 0.00		SBTL	0.00
			P1L1

Example

REG	0001
1@ \$2.50	2.50
PL00001	
TAX 0.15 SBTL	2.65
	P1L1

CHK.MN	
1 CHECK1	
2 CHECK2	
3 CHECK3	
4 CHECK4	
5 CHECK5	
TAX 0.15 SBTL	2.65
	P1L1

REG	0001
1@ \$2.50	2.50
ENTER AMOUNT	
	2.65
TAX 0.15 SBTL	2.65
	P1L1

Selling the PLU no.1 item and finalizing through check 1

1. Press the numeric 1 key and .

2. Press the  key.
• The CHECK menu window will appear.

3. Select "CHECK1."

4. Enter the amount.

Item Entries

■ Single item entries

Department entries (direct department entries)

Enter a unit price and press the department key.

If you use a programmed unit price, press the department key only.

Procedure

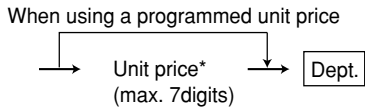

*Less than the programmed upper limit amount

NOTE

When those departments where the unit price has been programmed as zero (0) are entered, only the sales quantity is added.

Department entries (indirect department entries)

Procedure

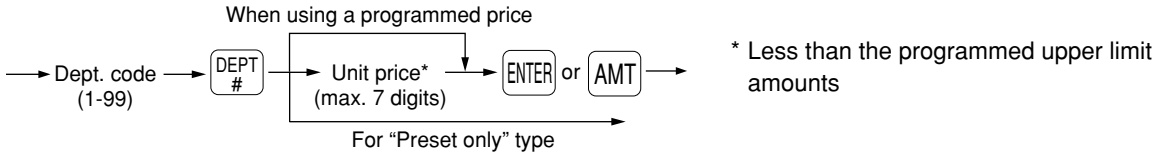

PLU entries (indirect PLU entries)

Enter a PLU code and press the key.

Procedure



NOTE

When those PLUs for which the unit price has been programmed as zero (0) are entered, only the sales quantity is added.

Subdepartment (open PLU) entries

Procedure

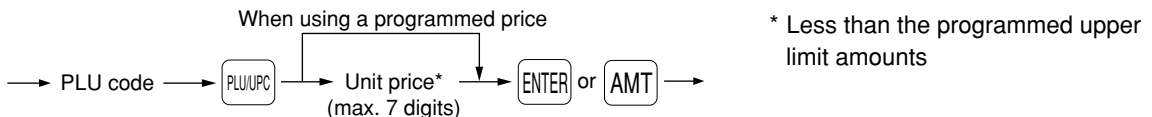

PLU entries (direct PLU entries)

Procedure

When using a programmed price

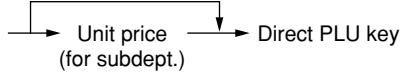

PLU menu-based entries (PLU entries and subdepartment entries)

Follow this procedure:

Procedure

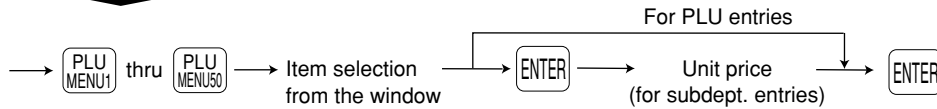

UPC entries

Procedure

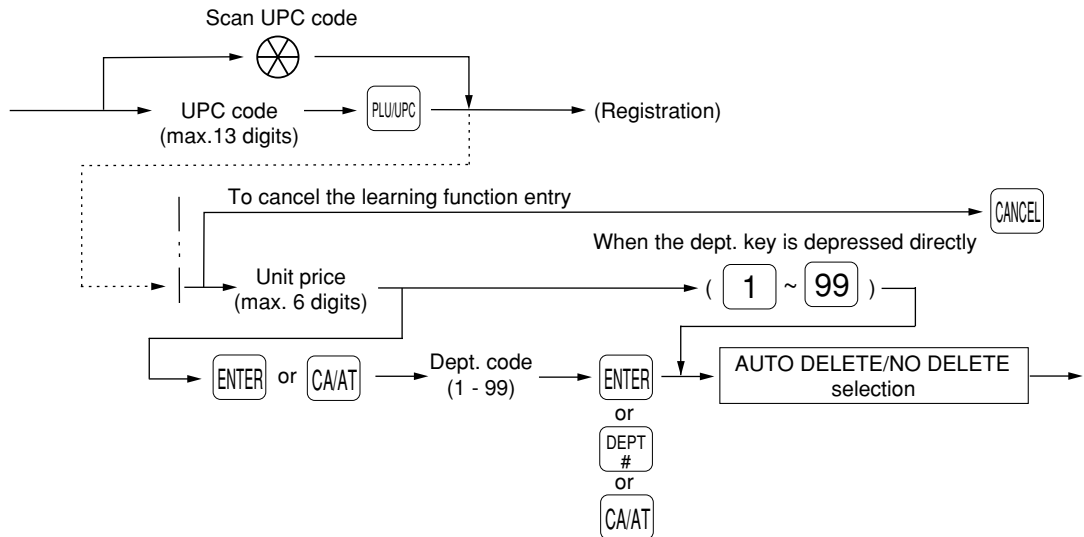

Repeat entries

You can use this function for repetitive entries of the same items. Simply press the repeat function key after valid item entries.



■ Multiplication entries

Use this feature when you need to enter two or more of the same items.

This feature helps you when you sell large quantities of items or need to enter quantities that contain decimals.

Procedure

FF method (for quick multiplication of direct PLUs)

Q'ty → Direct PLU PLU entry (direct)

- The FF (fast food) method cannot be used for a COUPON-LIKE PLU entry.

Normal method

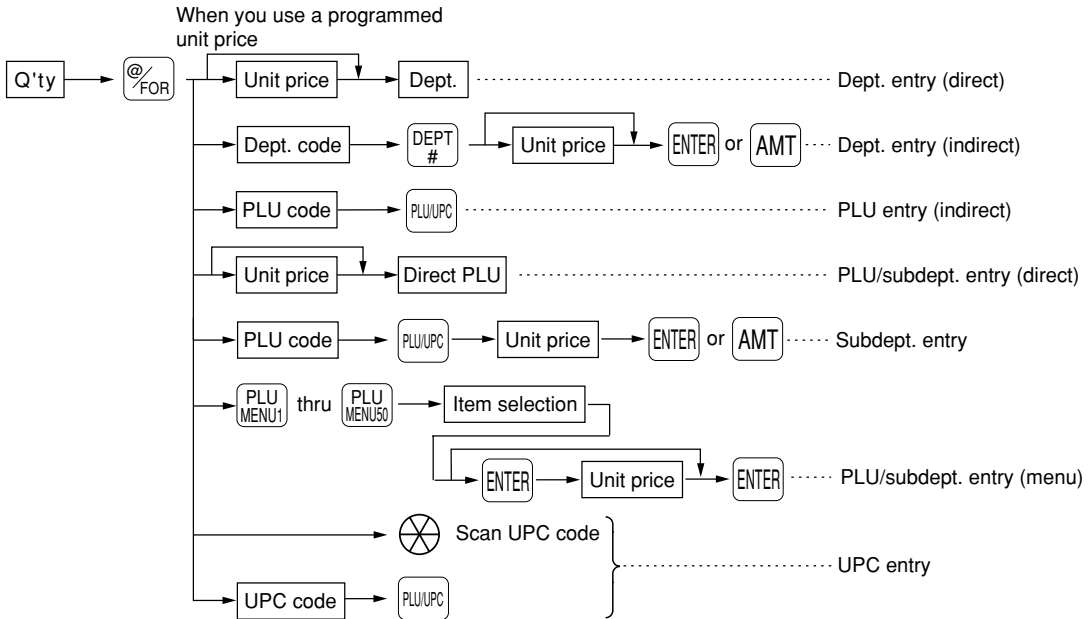



- With the learning UPC function, after scanning a UPC code or pressing the **PLU/UPC** key, you may be required to enter a unit price with the display “UNDEFINED CODE”. Enter the unit price and department code that the UPC is to be associated to.
- Q'ty: Up to four digits integer + three digits decimal
- Unit price: Less than the programmed upper limit
- Q'ty x unit price: Up to seven digits

■ Split-pricing entries

You will use this function when your customer wants to purchase items normally sold in bulk.

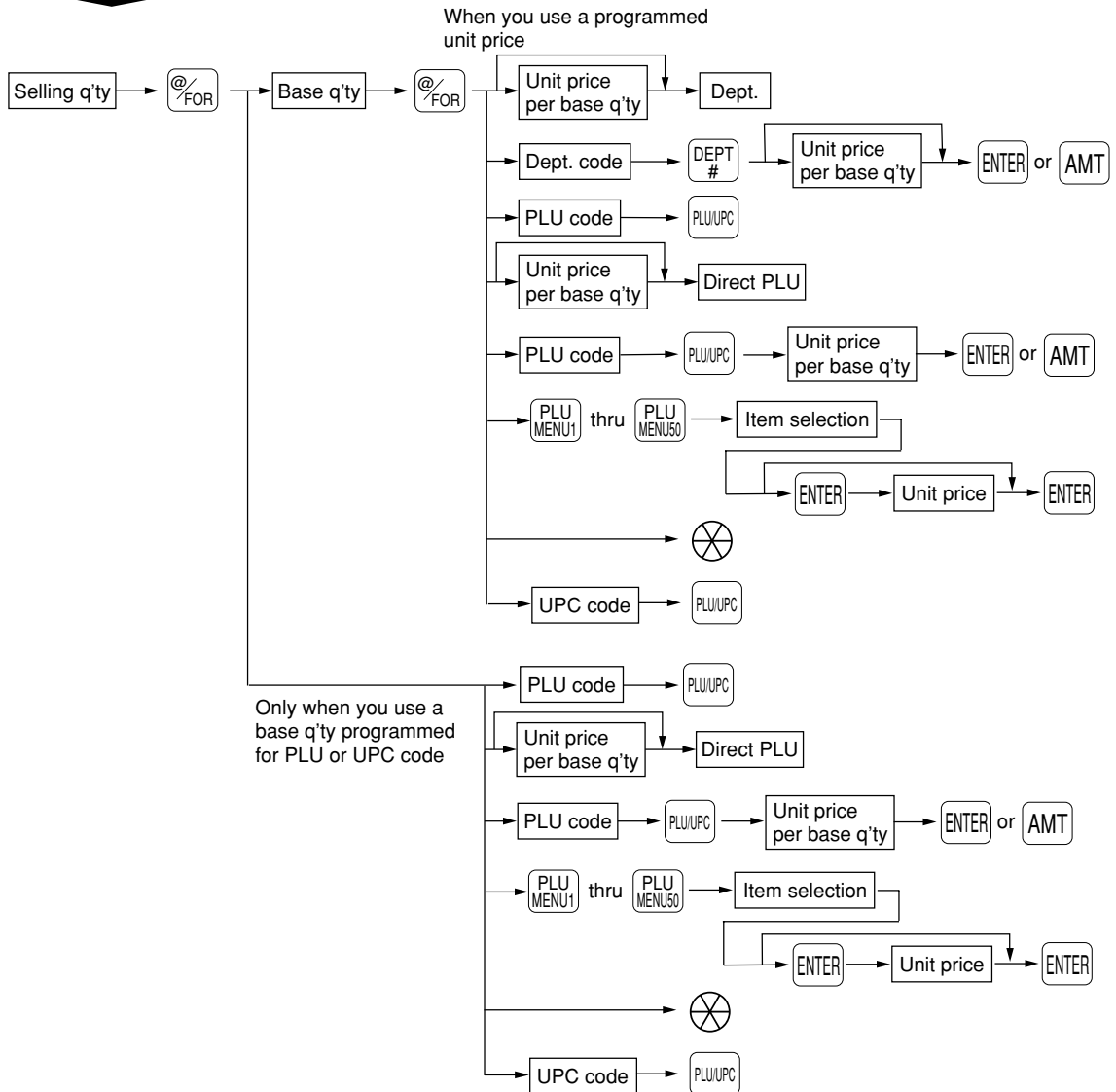
Procedure



- With the learning UPC function, after scanning a UPC code or pressing the  key, you may be required to enter a unit price with the display “UNDEFINED CODE”. Enter the unit price and department code that the UPC is to be associated to.
- Selling quantity: Up to four digits integer + three digits decimal
- Base quantity: Up to two digits (integer)

NOTE For actual use of this function, please consult your dealer.

■ Successive multiplication entries

This function is practical for such entries as a sale of an item sold by area (square foot).

Procedure

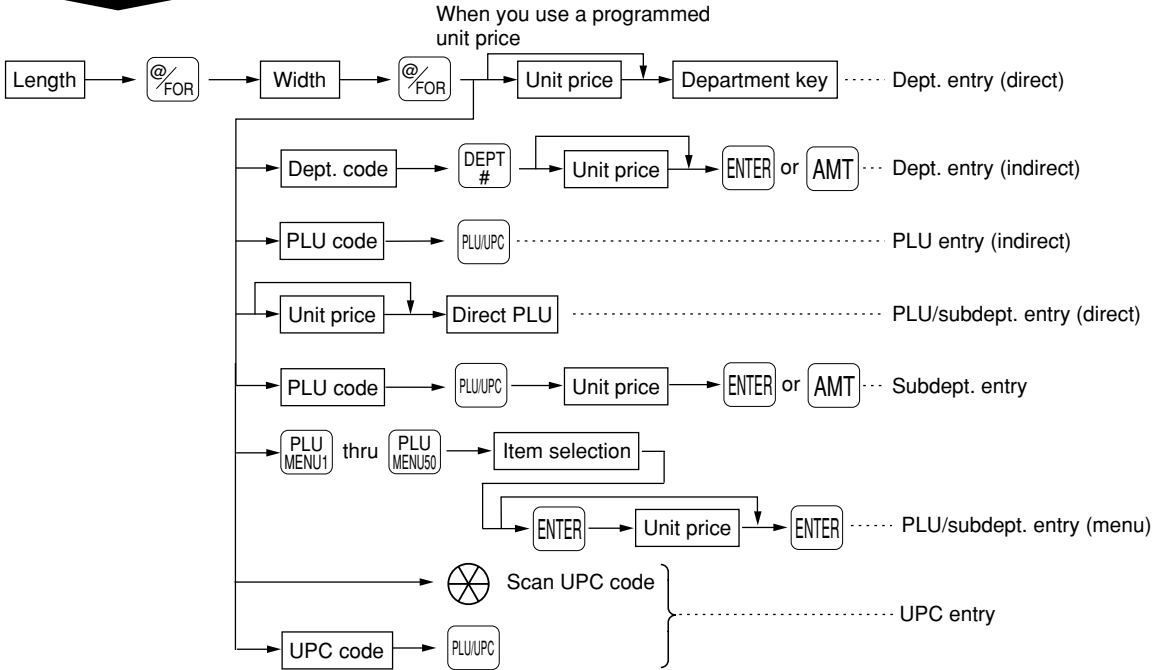

- With the learning UPC function, after scanning a UPC code or pressing the **PLUUPC** key, you may be required to enter a unit price with the display “UNDEFINED CODE”. Enter the unit price and department code that the UPC is to be associated to.
- Length or width: up to seven digits (4-digit integer + 3-digit decimal)
- Unit price: less than the programmed upper limit
- Length x Width x Unit price: up to seven digits

NOTE For actual use of this function, please consult your dealer.

■ Scale entries

For making entries for weighed items, a scale must be connected where by the weight is automatically read from the scale. To make refund entries, the weight is entered manually while the scale platter is empty and reads zero.

i) Auto scale entries

Procedure

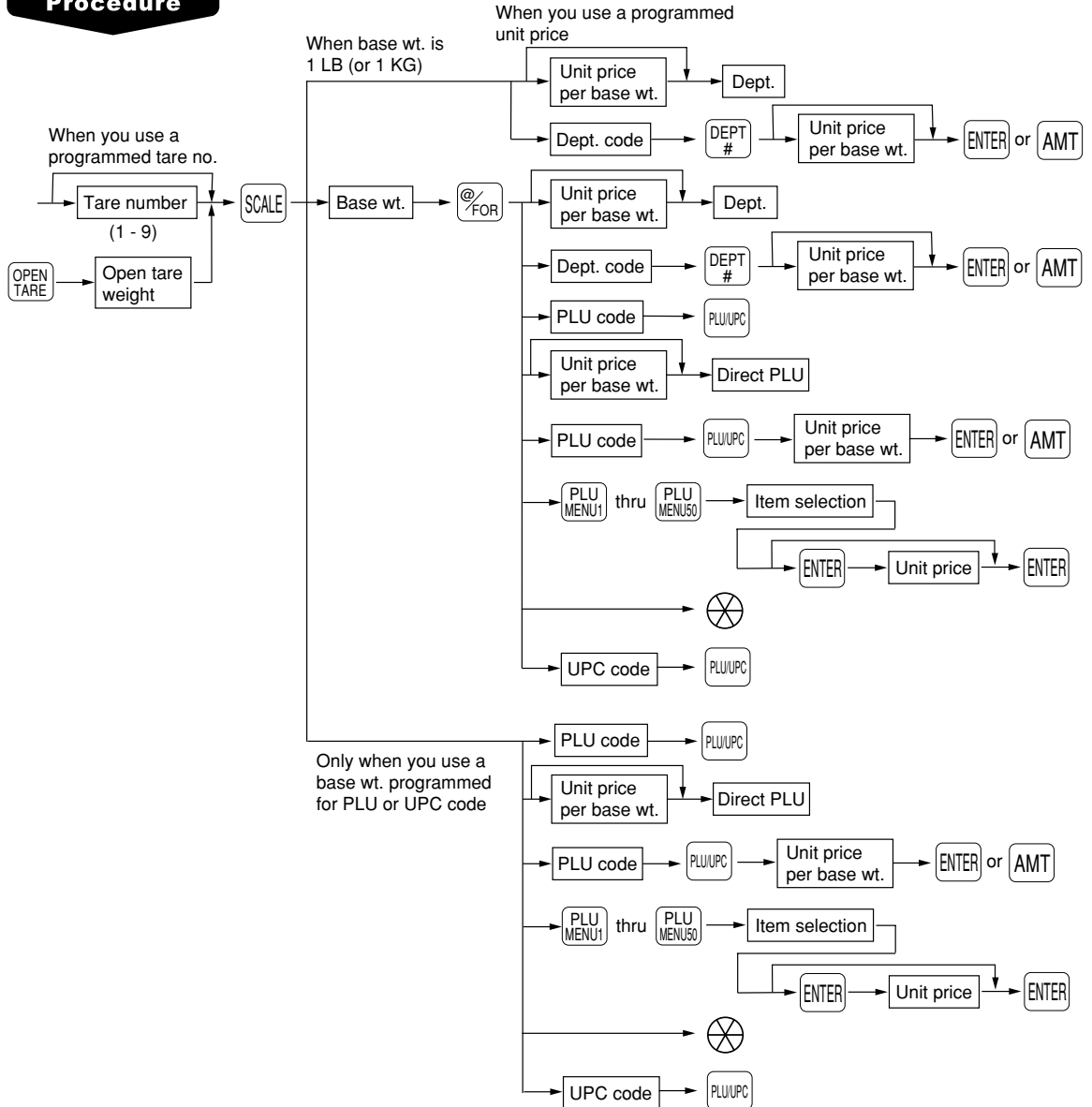

- Open tare weight: Up to 5 digits (integer + decimal)
- Net weight: Up to 5 digits (integer + decimal)
- Base weight: Up to 2 digits (integer)

NOTE

- The register can be programmed with up to nine tare tables and allows different tares to be assigned to them.
- When the **SCALE** key is pressed, the weight is automatically read from the connected scale (option) and the net weight appears in the register display.
- When the item is programmed for "Scale compulsory", it is not necessary to press the **SCALE** key.

ii) Manual scale entries for refunds only

Procedure

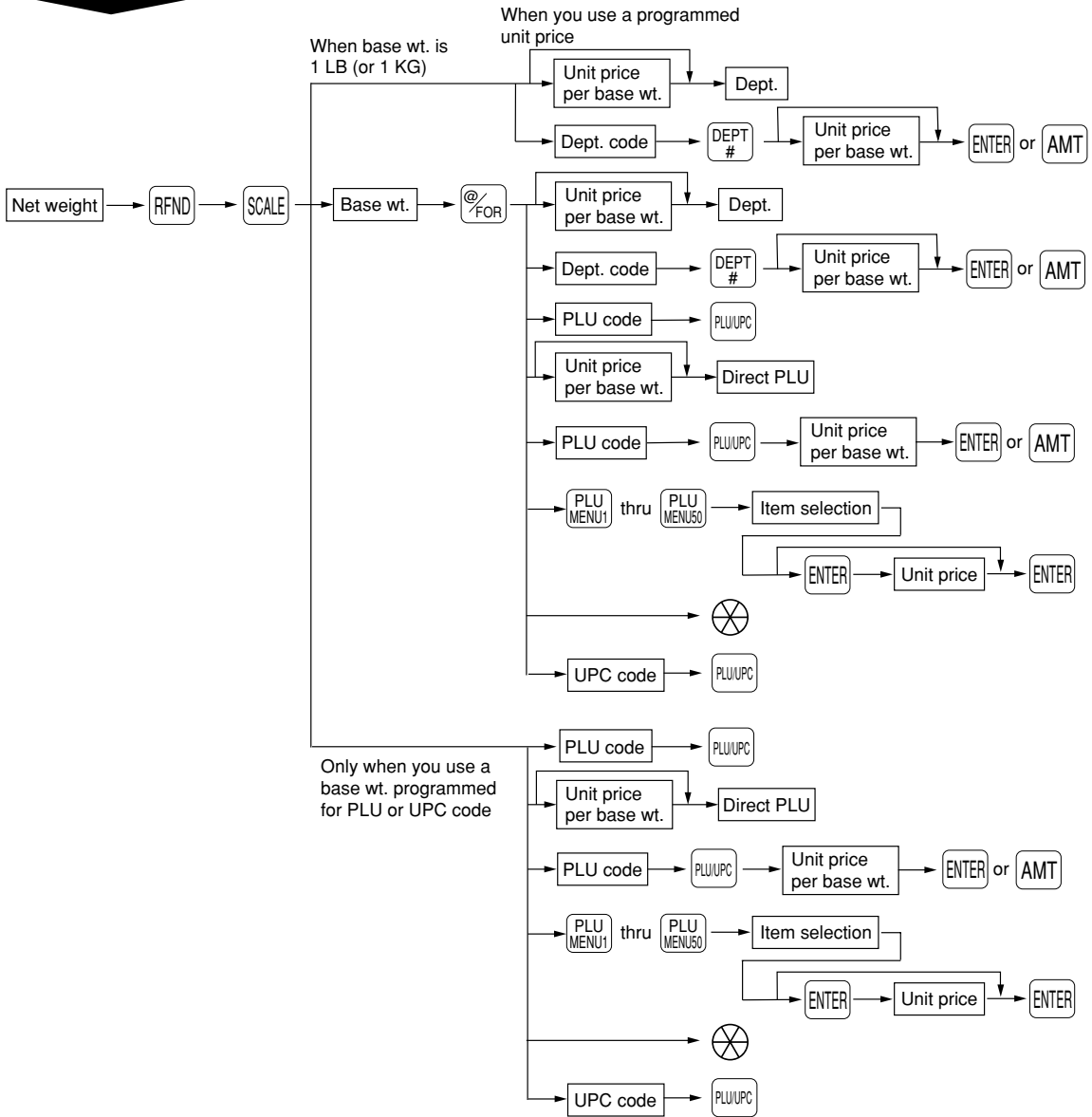

- Net weight: Up to 5 digits (integer + decimal) which is from the customer's receipt.
- Base weight: Up to 2 digits (integer)

■ Single item cash sale (SICS) entries

SICS entries

- This function is useful when a sale is for only one item and is for cash; such as a pack of cigarettes. This function is applicable only to those departments that have been set for SICS or to their associated PLUs, subdepartments or UPCs.
- The transaction is finalized and the drawer opens as soon as you press the department key, **AMT** key, **PLU/UPC** key or the direct PLU key.

NOTE *If entries to a department, PLU/subdepartment or UPC set for SICS follows entries to departments, PLUs/subdepartments or UPC not set for SICS, it does not finalize and results in a normal sale.*

SIF entries

- If entries to a department, PLU/subdepartment or UPC set for SIF follows entries to departments, PLUs/subdepartments or UPC not set for SIF, the transaction is finalized immediately as a cash sale.
- Like the SICS function, this function is available for single-item cash settlement.

■ Age verification (Birthday entry)

The age verification function is used for prohibiting the selling of goods (departments, PLUs, or UPCs) for certain aged persons based on a registered birthday.

When a department/PLU/UPC for which a figure other than zero (01 to 99) has been programmed as the age limitation is entered (in years), a birthday entry must be completed.

Procedure

→ XXXXXX → **BIRTH**

Birthday (five or six digits)

- NOTE**
- A birthday entry can be performed two or more times at any point during a transaction, however the last entered birthday remains in effect.
 - You can enter the date as far back as 98 years.
*[Ex.] When the current year is 1998 : you can enter the year 1900-1998.
When the current year is 2001 : you can enter the year 1903-2001.*

■ Link PLU/UPC entries

The operation is the same as normal PLU's/UPC's. When this PLU/UPC is entered, the linked PLU's amount is included and the linked PLU's label is printed automatically. Only the 1st PLU is affected by the status shift keys (**TAX1 SHIFT**, **TAX2 SHIFT**, **TAX3 SHIFT**, **TAX4 SHIFT** or **FS SHIFT** keys). The percent calculation is in effect for the amount of the 1st linked PLU.

■ Mix-and-match function

This function is convenient for matching several PLU/UPC items and selling them in together (e.g. bundle sale, multi-packed sale, etc.). The base q'ty and unit price are assigned to a mix-and-match table. All items that are programmed into the same table are treated as if they belong to one group.

■ Combo meal entries

The operation is the same as a normal PLU entry.

When a combo meal is entered with the Combo function keys, the labels of those PLUs linked to the Combo key can be printed automatically. The sum of all adjusted prices (of those PLUs linked to the Combo key) becomes the "combo meal" price that is registered.

NOTE

- *When combo meal is registered, the q'ty totalizer of the combo key and amount totalizer of each PLU are updated.*
- *When the  key is pressed under the cursor pointing a combo meal, the combo meal entry of 1st price level is voided and the new combo meal of 2nd price level is registered.*

■ Condiment entries (for PLU)

Your POS terminal may be programmed for prompting condiment and preparatory instructions for a menu-item PLU.

Example:





When you enter a menu-item PLU, a prompting message such as “HOWCOOK?” and a list of the “Following PLUs” will appear. You must specify one of the “Following PLUs” such as “without mustard” to meet a special order of the guest. In an example of the condiment table shown below, it is assumed that the condiment table no.1 is assigned to PLU code 21 (programmed text “STEAK”) and table no. 4 is assigned to table no. 1 as the next table no. When you enter the PLU code 21, the message “HOWCOOK?” will appear to prompt you to specify one of “RARE,” “MED.RARE,” and “WELLDONE.” If the guest chooses “RARE,” select it from the list. Then the next message “POTATO?” will appear to prompt you to specify one of “P.CHIPS,” “MASHED.P,” and “BAKED.P.” If the guest chooses “MASHED.P,” select it. Then press the  key to end this entry.

Here is an example of how to perform a condiment entry when your condiment table is as shown below.

Table number	PLU codes for condiment entry (programmed text, price)			Next table no.	
1	(HOWCOOK?)	23 (RARE 0.00)	25 (MED.RARE 0.00)	27 (WELLDONE 0.00)	4
4	(POTATO?)	33 (P. CHIPS 0.60)	37 (MASHED.P 0.60)	38 (BAKED.P 0.50)	_____



Menu-item PLUs
Message text
PLUs

NOTE



- Your POS terminal will continue to prompt for the condiment entry until you finish the entire condiment entry programmed for the PLU. During the condiment entry, if you enter a normal PLU, which is not in the condiment table, an error message will appear.
- When the  key is pressed, the entry skips to the next table which is programmed.
- When the  key is pressed, its condiment entry is canceled in the programmed mode (REG/MGR or MGR).
- When you enter a PLU priced at “0.00,” only the text may be printed on the receipt.
- No refund entry is possible for any condiment entries. When you perform a refund entry with a menu-item PLU the condiment PLUs assigned to the menu-item PLU are automatically registered as a refund entry.
- You may omit the compulsory condiment entry by pressing the  key.
- The cursor void entry is allowed for those PLUs that are entered as condiments (menu and condiment).
- The multiplication entry can be made for each condiment item independently. However, the sum of the entered quantity per condiment table have to be same or below a menu PLU registration. When no multiplication entry is made, the quantity is decided automatically to reach the number of the menu PLU registration.
- You can press the  key to shift a price level during the condiment PLU entry.

■ Repeat round entries

This function can be used for reorder entries of PLU items (single PLU item and condiment PLU) simply by depressing the  key. To use this function, the PLU must be preset as “yes” for repeat entries.

At the first depression of the  key, those items that were previously registered in a transaction are subjected for reordered items, and at the second depression of the  key, those items that are registered after the previous depression of the  including the items of first reordered items are subjected for reorder items.

NOTE

When the  key is pressed just after the depression of the  key, all items subjected to the repeat round entry are voided.

■ Price inquiry (view) function (for PLU/UPC)

You can use this function when you want to know the unit price of the PLU/UPC item during transaction in the REG/MGR mode.

Procedure

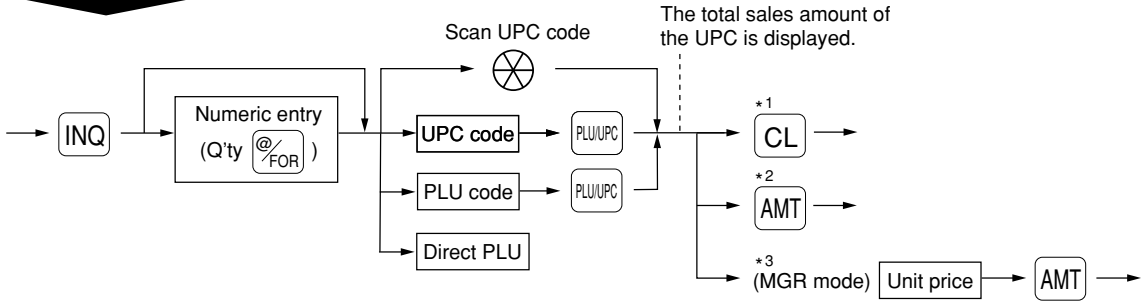

*1: Press the **CL** key to cancel the the inquiring (view) mode.

*2: Press the **AMT** key when you want to register the unit price of the PLU/UPC displayed.

*3: You can change the unit price temporarily in the MGR mode. The unit price which is programmed in PGM mode is not changed (This is considered a price override entry).

NOTE For the repeat entry, use the **REPEAT** key.

■ UPC learning function

When you enter or scan an undefined code, you are required to enter its unit price and the associated department. The UPC code, associated department and unit price entered are stored in the UPC file and used for future UPC sales entries.

- NOTE**
- When there is no capacity remaining in the file, the data is not stored in the file.
 - The text of its associated department is applied to the entered UPC code.
 - You can use the UPC learning function in the training mode. This may be convenient to practice when installing a scanning system.

Procedure

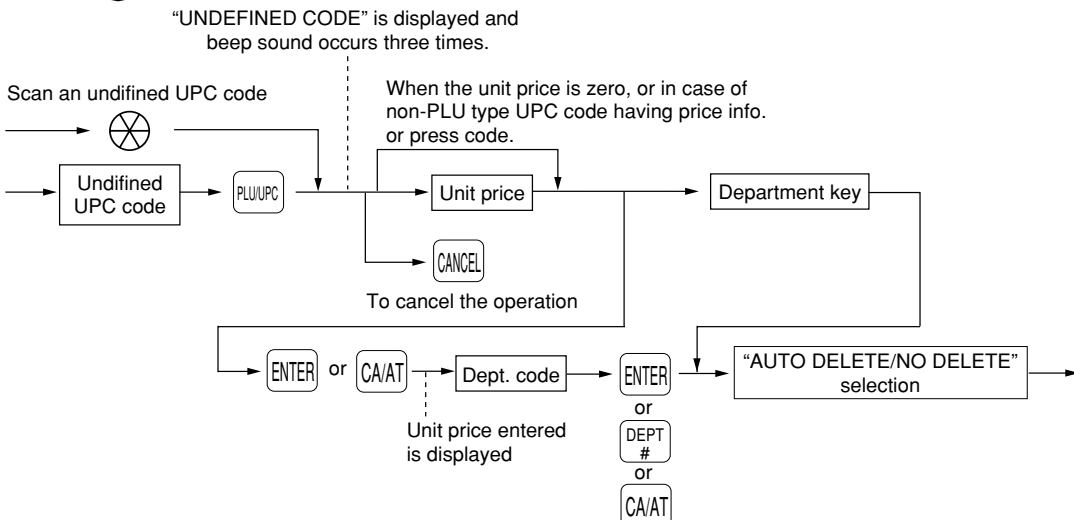

NOTE For the repeat entry, use the **REPEAT** key.

■ Price change function (for UPCs)

You can use this function when you need to change the unit price or associated department of a UPC item in REG/MGR mode.

There are two methods for the price change function:

1. Price change mode

You can change the preset price and/or the associated department of a UPC item without entering PGM mode.

2. Changing the price during a transaction

When a wrong UPC price and/or associated department is found during a transaction, you can correct them at the time of transaction. With the entry of a new price and/or associated department, the preset price and/or associated department is automatically changed to the new price and/or associated department.

NOTE For the Non-PLU type price embedded UPC-A codes and press codes, the prices in the codes have the priority over the preset prices. So, for these codes, a changed price is valid only when the price change is executed.

Procedure

Price change mode

"PRICE CHANGE" is displayed.

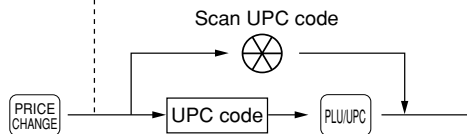

Changing price during a transaction

Scan UPC code

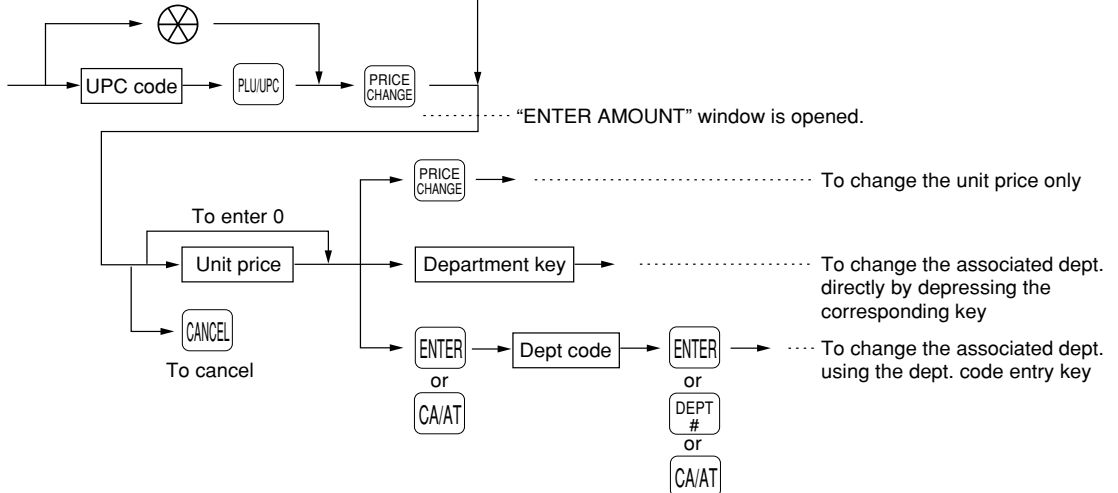

- NOTE**
- When an undefined code is entered in the price change mode, the register goes to an error status.
 - When you press the key during a transaction, the UPC entry is overridden upon the 1st depression of the key, then you are allowed to enter a correct price and/or associated department.
 - When an associated department is changed, the item label for the department will also be changed automatically to the item label of new associated department.
 - For the repeat entry, use the key.

■ PLU level shift (for direct PLUs)

This shift can add to the number of direct PLUs on your POS terminal without adding additional direct PLU keys. You can use direct PLUs in five levels by utilizing the PLU level shift keys **LEVEL 1** thru **LEVEL 5**. The level key shifts the PLU level from the other four to the required level. (The normal level is level 1.) You must program your machine in the PGM2 mode to select one of the two PLU level shift modes — automatic return mode* or lock shift mode** — and decide whether to allow the PLU level shift in both the REG and MGR modes or in the MGR mode only.

* The automatic return mode automatically shifts the PLU level back to the level programmed after pressing a direct PLU key or finalizing each transaction.

** The lock shift mode holds the current PLU level until another PLU level shift key is pressed.

Automatic return mode (for PLU levels)

If your terminal has been programmed for the PLU level in the automatic return mode, press a desired PLU level shift key before a numeric type entry.

Procedure

(Returning every item entry)

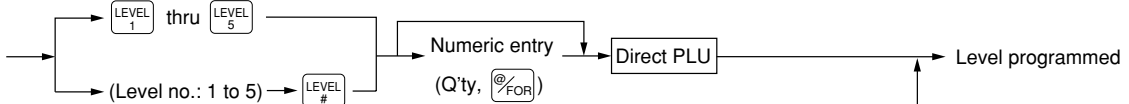

(Returning every transaction)

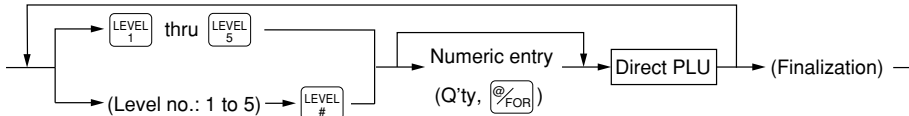

NOTE

When you use the FF method (PLU), you do not press the Ⓢ/FOR key on numeric entry.

Lock shift mode (for PLU levels)

If your terminal has been programmed for the PLU level in the lock shift mode, press a desired PLU level shift key before a numeric type entry.

Procedure

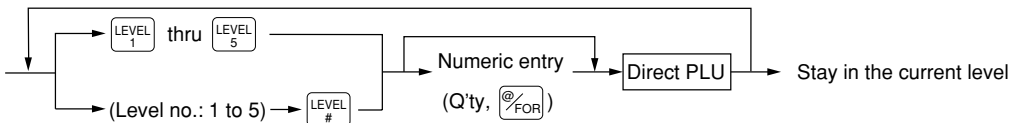

NOTE

• When you use the FF method (PLU), you do not press the Ⓢ/FOR key on numeric entry.

■ PLU/UPC price level shift







NOTE

To use this function, please contact your authorized SHARP dealer.

Six different price levels can be programmed for each PLU or UPC.

The price levels can be changed for PLU or UPC registrations.

These keys have the following functions:

-  : Shifts the PLU/UPC price level from level 2, 3, 4, 5, or 6 to level 1 (base level).
-  : Shifts the PLU/UPC price level from level 1, 3, 4, 5, or 6 to level 2. When you press this key, the price level shift indicator will turn to "P2."
-  : Shifts the PLU/UPC price level from level 1, 2, 4, 5, or 6 to level 3. When you press this key, the price level shift indicator will turn to "P3."
-  : Shifts the PLU/UPC price level from level 1, 2, 3, 5, or 6 to level 4. When you press this key, the price level shift indicator will turn to "P4."
-  : Shifts the PLU/UPC price level from level 1, 2, 3, 4, or 6 to level 5. When you press this key, the price level shift indicator will turn to "P5."
-  : Shifts the PLU/UPC price level from level 1, 2, 3, 4, or 5 to level 6. When you press this key, the price level shift indicator will turn to "P6."

* The automatic return mode shifts the PLU/UPC price level back to level 1 after a PLU entry automatically. You can select whether the PLU/UPC price level should return each time you enter one item or each time you finalize one transaction.

** The lock shift mode holds the current PLU/UPC price level until pressing a price level shift key.

Automatic return mode (for price shifts)

If your terminal has been programmed for PLU/UPC price level in the automatic return mode, press a desired price level shift key before a numeric type entry.

Procedure

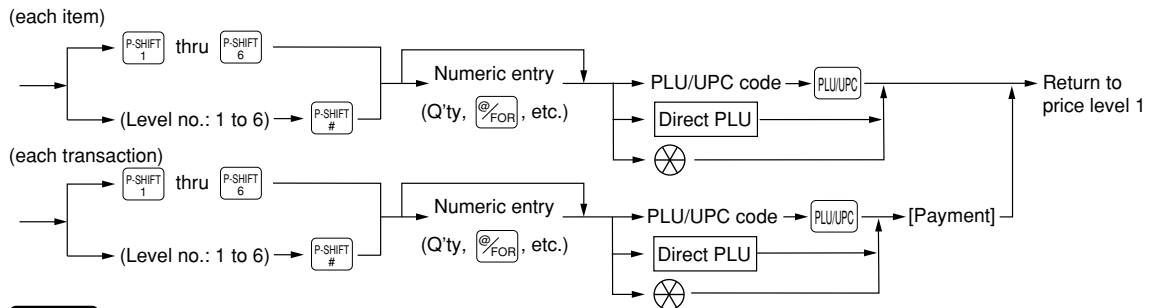

NOTE

When you use the FF method (PLU), you do not press the  key on numeric entry.



Lock shift mode (for price shifts)

If your terminal has been programmed for PLU/UPC price level in the lock shift mode, press the desired price level shift key before a numeric entry.

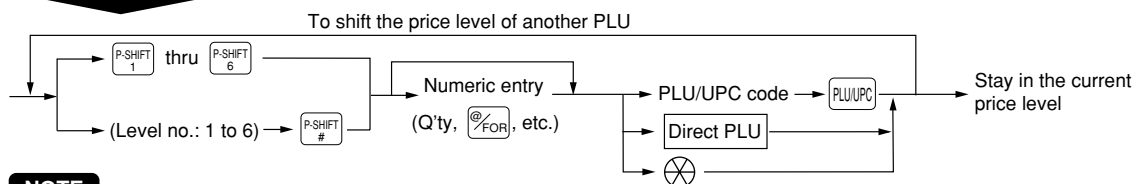
Procedure



NOTE

- If you select the automatic return mode, it is not necessary to use the  key on the keyboard. If you select the lock shift mode, it is necessary to use the  key.
- When you use the FF method (PLU), you do not press the  key on numeric entry.

Display of Subtotals

Your POS terminal provides these five types of subtotals:



■ Merchandise subtotal

You may press the  key at any point during a transaction.



The net sales subtotal - not including tax - and the symbol "MDSE ST" will appear in the display.

■ Taxable subtotal



Taxable 1 subtotal

Press the  and  keys in this order at any point during a transaction. The sales subtotal of taxable 1 items will appear in the window and the caption "TAX1" and the tax 1 amount will appear.



Taxable 2 subtotal

Press the  and  keys in this order at any point during a transaction. The sales subtotal of taxable 2 items will appear in the window and the caption "TAX2" and the tax 2 amount will appear.

Taxable 3 subtotal

Press the  and  keys in this order at any point during a transaction. The sales subtotal of taxable 3 items will appear in the window and the caption "TAX3" and the tax 3 amount will appear.

Taxable 4 subtotal

Press the  and  keys in this order at any point during a transaction. The sales subtotal of taxable 4 items will appear in the window and the caption "TAX4" and the tax 4 amount will appear.

■ Including-tax subtotal (full subtotal)

You may press the  key at any point during a transaction. The sales subtotal including tax and the symbol "SUBTOTAL" will appear in the display.

■ Tray subtotal

You may press the  key during a transaction in the REG or MGR mode.

The contents of the tray total itemizer which includes tax are printed and displayed.

■ Eat-in subtotal

You may press an eat-in key prior to entering a payment. Your POS terminal will calculate a subtotal according to the programmed tax exemption status and display the subtotal, the symbol "EAT IN," and a corresponding caption ("EAT IN 1," "EAT IN 2," or "EAT IN 3") will be displayed.



For the transaction with the eat-in subtotal, you must finalize the transaction by making a payment entry. Just after pressing the eat-in key, however, you can cancel the entry of that key by pressing the  key or another eat-in function key.

■ Food stamp-eligible subtotal



You may press the  key at any point during a transaction. The sale subtotal of items eligible for food stamp payment will appear in the display.

■ Group discountable subtotal



Group 1 discountable subtotal

You may press the  and  keys in this order at any point during a transaction.

Group 2 discountable subtotal

You may press the  and  keys in this order at any point during a transaction.

Group 3 discountable subtotal

You may press the  and  keys in this order at any point during a transaction.

■ Gasoline discount subtotal

You may press the  key and select the payment media at any point during a transaction. The gasoline discount subtotal will appear in the display.

Finalization of Transaction

■ Cash or Check tendering

Press the **[SBTL]** key to get the including-tax subtotal, enter the amount tendered by your customer, then press the **[CA/AT]** thru **[CAS]** key if it is a cash tender or press the **[CHK 1]** thru **[CHK 5]** key if it is a check tender. When the amount tendered is greater than the amount of the sale, your POS terminal will show the change due amount and the symbol "CHANGE." Otherwise your POS terminal will show the symbol "DUE" and a deficit. To settle the deficit amount, another tender amount exceeding the amount due must be entered.

NOTE

- You can also enter a check or cash tender from the check or cash menu window. Press the **[CHK #]** or **[CASH #]** key and select the desired check or cash media key and enter the amount.

■ Mixed tendering (check + cash)

Mixed tendering of check and cash is available. After pressing **[SBTL]** key, enter the amount tendered by your customer in check or cash, and press the corresponding key, then again enter the amount tendered in cash or check, and press the corresponding key.

■ Cash or check sale that does not need any tender entry

Enter items and press the **[CA/AT]** thru **[CAS]** key if it is a cash sale or press the **[CHK 1]** thru **[CHK 5]** keys if it is a check sale. Your POS terminal will display the total sales amount.

■ Charge (credit) sale

Enter items and press the corresponding charge keys (**[CH 1]** thru **[CH 9]**).

NOTE

- Amount tendering operations (i.e. change calculations) can be achieved by the **[CH 1]** thru **[CH 9]** key when PGM2-mode programming has been preset for amount tender compulsory.
- When charge tendering is performed with CAT compulsory, the corresponding card authorization sequence is initiated.
- You can also enter a charge tender from the charge menu window. Press the **[CH #]** key and select the desired charge media key and enter the amount.

■ Mixed-tender sale (cash or check tendering + charge tendering)

In case of mixed tendering of cash and charge tendering, press the **[SBTL]** key to get an including-tax subtotal, enter the amount tendered in cash by your customer, and press the **[CA/AT]** thru **[CAS]** key. Then press a pertinent charge key to settle the payment of a deficit.

In case of mixed tendering of check and charge tendering, press the **[CHK 1]** thru **[CHK 5]** keys in place of the **[CA/AT]** thru **[CAS]** key.



■ Food stamp tendering

If your customer makes payment (or tendering) in food stamps, obtain the food stamp-eligible subtotal* by pressing the  key and make a food stamp tender entry before entering a cash or check tender.

* Note: The food stamp-eligible subtotal depends upon how your machine is programmed about the food stamp-eligibility of the automatic tax on a sale of items eligible for food stamp payment, or whether your machine is programmed to allow the automatic tax to be paid with food stamps or not or to exempt taxation. The example below presupposes that your machine has been programmed to exempt taxation.

- ① When the amount tendered in food stamps is greater than the food stamp-eligible subtotal:
Your machine shows two change due amounts in its display. The food stamp change due appears at the left of the display in dollars and the cash change at the right in cents.
- ② When the food stamp tender is smaller than the food stamp-eligible subtotal:
 - Accept the remainder in food stamps or in cash or check.
However, if your machine is programmed to exempt taxation, it cannot accept additional food stamp tender.

■ Food stamp status shift

Your machine allows you to shift the programmed food-stamp status of each department,  thru , percent key, the UPC or the PLU key by pressing the  key prior to those keys. After each entry is completed, the programmed food stamp status is resumed.

Tax Calculations

■ Automatic tax

When your POS terminal is programmed with a tax table (or tax rate) and the tax status of an individual department or PLU is set for taxable, it computes the tax automatically on any item that is entered into the department directly or indirectly via a related PLU.

■ Manual tax

Your POS terminal allows you to enter tax manually after item entries.
After items entry, enter tax amount and press the **TAX** key.

■ Tax deletion

You can delete the automatic tax on the taxable 1, taxable 2, taxable 3, or taxable 4 subtotal of each transaction by pressing the corresponding TAX SHIFT key followed by the subtotal, then the **TAX** key after the subtotal is displayed.

NOTE

If any of the media keys (i.e. cash, check 1 thru check 4, or charge 1 thru charge 8) is programmed for tax delete in the PGM2 mode, the tax can be deleted without using the procedures above. In this case pressing a corresponding media key that has been programmed will always cause the selected tax to be deleted.

■ Tax status shift

Your POS terminal allows you to shift the programmed tax status of each department, discount, or percent key or of the PLU key by pressing the **TAX1 SHIFT**, **TAX2 SHIFT**, **TAX3 SHIFT** and/or **TAX4 SHIFT** keys before those keys are pressed. After each entry is completed, the programmed tax status of each key is resumed.

NOTE

The entry of a multi-taxable item for PST or GST will be prohibited as follows (for Canada):

In case of; Tax 1: PST, Tax 2: PST,
Tax 3: PST, Tax 4: GST

Taxable 1 and 2 item	prohibited
Taxable 1 and 3 item	prohibited
Taxable 2 and 3 item	prohibited
Taxable 1 and 4 item	allowed
Taxable 2 and 4 item	allowed
Taxable 3 and 4 item	allowed

In case of; Tax 1: PST, Tax 2: PST,
Tax 3: GST, TAX 4: GST

Taxable 1 and 2 item	prohibited
Taxable 1 and 3 item	allowed
Taxable 2 and 3 item	allowed
Taxable 1 and 4 item	allowed
Taxable 2 and 4 item	allowed
Taxable 3 and 4 item	prohibited

Guest Check (GLU/PBLU)

Two different guest check entry systems are available: the GLU system and previous balance lookup (PBLU) system. It depends on how your POS terminal has been programmed which of these is used. (Contact your authorized SHARP dealer for this selection.)

GLU system: If this system is selected, the balance due and the details of the order are placed in the guest check file. The information can be automatically recalled by pressing the **[GLU RECALL]** key, or entering a GLU code when additional ordering or finalization is required.

PBLU system: If this system is selected, the previous balance is stored in the previous balance lookup file (PB lookup file). The information can be automatically recalled by entering a previous balance lookup code (a PBLU code) when additional ordering occurs.

■ GLU/PBLU system

New guest

For a new guest;

Procedure

For automatic GLU/PBLU code generation

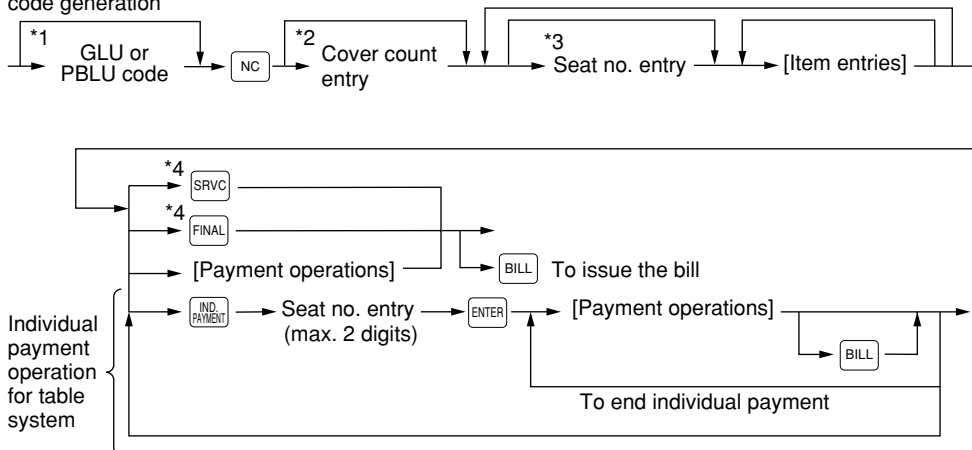

NOTE

- The GLU/PBLU code refers to a number/code that will be used whenever the guest check must be accessed for re-ordering or final payment. The range of GLU or PBLU codes that can be entered in each terminal can be programmed, and also can be specified in OP X/Z mode for each server.
- Your POS terminal can be programmed for table #/PBLU codes in a sequential fashion. If your POS terminal has not been programmed to do so, each table #/PBLU code can be entered manually.

*1 GLU/PBLU code: 1 to 9999

When the range of GLU or PBLU codes is programmed in PGM2 mode and/or specified in OP X/Z mode, the GLU that can be entered is limited to the range.

*2 The cover count refers to the number of people in the party. When the cover count entry is compulsory, you must enter the cover count (max.2 digits). When cover count is not compulsory, enter the cover count and press the **[COVER CNT]** key, however, it is automatically calculated by the number of times the **[SEAT #]** key is pressed in table system. (When the cover count is not entered and the **[SEAT #]** key is not pressed, the cover count is counted as 1.)

*3 Seat # entry is only for the table system.

When the seat # entry is compulsory, you must enter a seat #. To enter the first person #, enter the seat # (max. 2 digits) and press the **[ENTER]** key. To enter the second person# or later, enter the number and press the **[SEAT #]** key.

The number of times of the seat # entry must not exceed the previously entered cover count when it entered.

*4 These are the optional functions (Temporary finalization).

You can temporarily finalize a guest check by pressing the **SRVC** or **FINAL** key. It is recommended to use the **SRVC** key to temporarily finalize a guest check when printing is not desired and to use the **FINAL** key when printing the current balance including tax is desired. The guest check, however, is still "open". This means you can still make addition orders to it.

GLU recall

Each server can recall his or her GLUs for reorder entry or settlement by pressing the **GLU RECALL** key. On the display, the list of GLU that are still open are displayed. Then select the desired GLU and press the **ENTER** key, or enter the desired GLU and press the **GLU** key while the recall window is shown on the display. When programmed, the recall window will be displayed automatically.

GLU RC	
#1	9.30
#2	9.12
#3	27.87
TAX 0.00	SBTL 0.00
P1L1	

An example of GLU recall window

Reorder entries

For making additional guest check entries;

Procedure

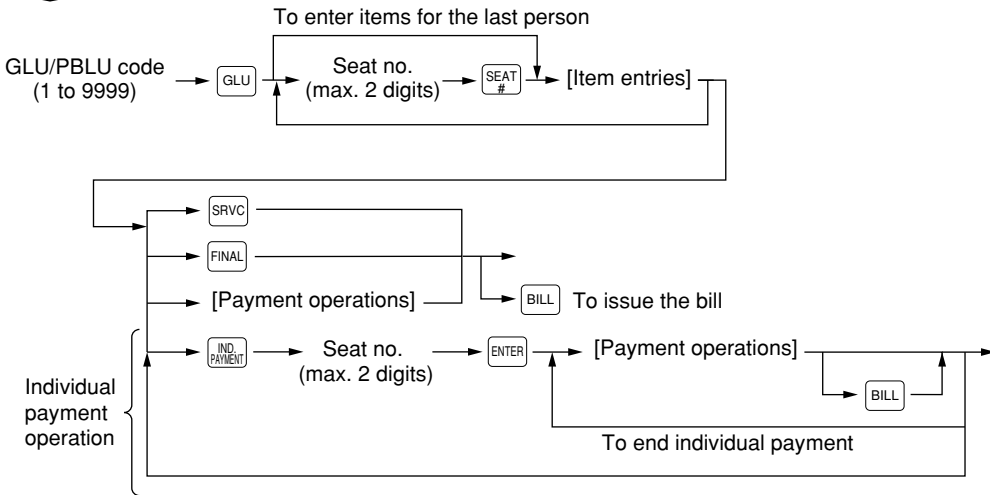

Settlement

Use the following procedure:

Procedure

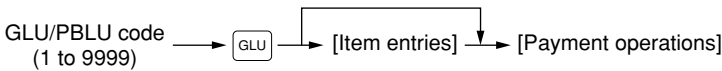

NOTE

You can make a tip-in entry before a tender entry. If a tip-in entry is made, the tip amount must be tendered by using the associated media key e.g. CH1 thru CH9 for the charge tip and CASH 1 thru CASH 5 for the cash tip.

■ Deposit entries

Deposit refers to a prepayment on a guest check. It can be received in cash check or charge tenders. You can make a deposit entry only when entering a guest check. It cannot be done during handling of a tendered amount.

A received deposit can be refunded by pressing the  key. You cannot attempt to refund an amount larger than the deposit balance.

Procedure

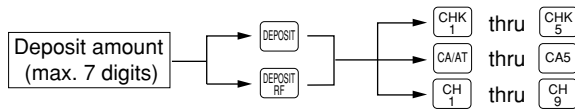

■ Transferring guest checks out or in (Transfer-out/in)

Transferring guest checks out

At the end of a server shift or whenever a server is relieved, one or more open guest checks can be transferred from the server to the open check file until the responsibility for the check(s) is assigned to another server.

Procedure



Transferring guest checks in

When the second server is assigned to be responsible for guest checks that have been transferred out:

Procedure

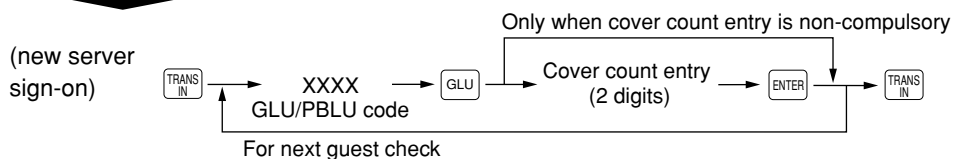

■ Bill totalizing/bill transfer

Bill totalizing

The bill totalizing function is used to totalize multiple bills when, for example, a particular guest pays not only his or her bill, but also the bills of other guests (Adding guest checks).

Procedure

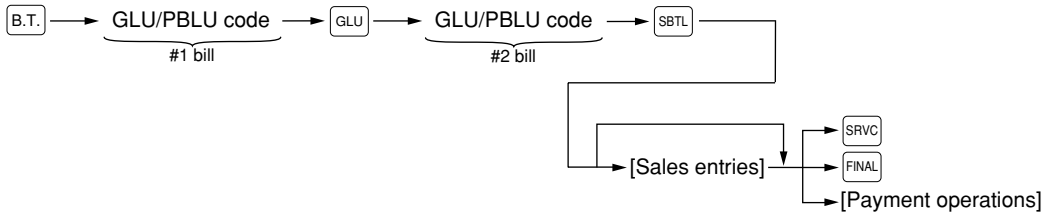

NOTE

- All #1 bills are added to a #2 bill. A maximum of 5 bills may be added to a #2 bill.
- The GLU/PBLU code of #1 must be in use. If the guest check(s) of #1 or #2 has already been handled by another server, the guest check(s) must have been made "Transferring out."
- After the bill totalizing operation, the individual payment function is not allowed.

Bill transfer

This function is used to change the GLU/PBLU code of a particular bill.

Procedure

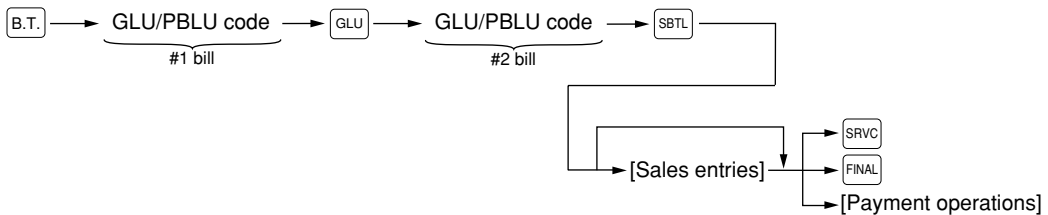

NOTE

- This function requires that the current GLU/PBLU code be entered for #1 and a new GLU/PBLU code be entered for #2.
- A #1 bill is transferred to a #2 bill. The #1 bill is then cleared and set free.

■ Bill separating

The function is used when each guest of a group pays his or her own order. With this function, you can select some items from a guest check and make an entry for the payment. Also, you can transfer the items you have selected to other guest checks. This function is available only in the GLU system.

Procedure

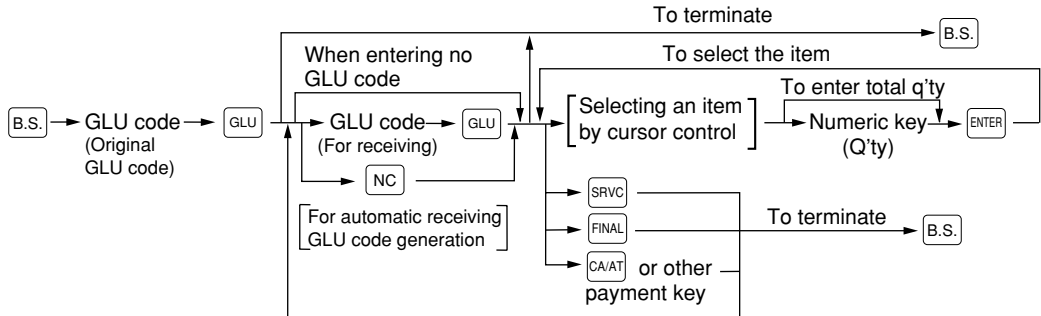

NOTE

- If the receiving GLU code is not entered during the bill separating operation, it is considered that the payment function has been made by pressing CA/AT key or other payment key.
- If a particular receiving GLU code is already in use, a lock error occurs when that number is entered.
- You cannot specify the quantity of an item for selection when the stored quantity has a decimal fraction.

■ Bill printing

This function is used for issuing the bill to the guest. Your POS terminal can print the bill (normal bill or cumulated bill) on the slip, roll, receipt, or journal printer. For selecting these printers, contact your authorized SHARP dealer.

Procedure

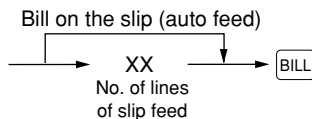

NOTE

- This function is available immediately after the finalization of transaction (including after pressing the **SRVC** or the **FINAL** key).
- If the copy function is allowed, you can print the bill copy on the slip and receipt only once. If you need the bill copy, contact your authorized SHARP dealer.

Auxiliary Entries

■ Percent calculations (premium or discount)

- Your POS terminal provides percent calculations for a merchandise subtotal or each item entry. You need to specify in advance for each merchandise subtotal or each item entry your POS terminal should perform a percent calculation.
- For percent calculations (premium, discount, merchandise subtotal or individual), you may use the thru key.
- Percentage: 0.01 to 99.99%

NOTE

- *For the ST % (merchandise subtotal) entry:*
The % entry will be allowed only when all PLUs which is associated to the % key have been entered.
- *For the Item % entry:*
The % entry will be allowed only for a PLU which is associated to the % key.

■ Discount entries

For discount or coupon tenderings, you may use the thru keys when it is allowed in programming. If the discount or tendered coupon is the one applicable to sales, use the vendor coupon; and if it is applicable to each item entry, use the store coupon.

NOTE

Discount entries can be overridden in MGR mode when it is not allowed in REG mode.

NOTE

- *For the vendor coupon entry:*
The coupon entry will be allowed only when all PLUs which is associated to the (-) key have been entered.
- *For the store coupon entry:*
The coupon entry will be allowed only for a PLU which is associated to the (-) key.

■ Refund entries

If a refunded item is to be entered into a department, enter the amount of the refund, then press the key and a corresponding department key in this order; and if an item entered into a PLU (or UPC) is returned, enter a corresponding PLU code (or UPC code), then press the and keys, or press the and direct PLU keys without entry of PLU code, in this order.

If an refunded item is to be entered into an open PLU, enter a corresponding PLU code, press the and keys, then enter price and press the .

■ Return entries

If a returned item is the one entered into a department, enter the amount of the return, then press the key and a corresponding department key in this order; and if an item entered into a PLU (or UPC) is returned, enter a corresponding PLU code (or UPC code), then press the and keys, or press the and direct PLU keys without entry of PLU code, in this order.

If an returned item is to be entered into an open PLU, enter a corresponding PLU code, press the and keys, then enter price and press the .

■ Printing of non-add code numbers

Enter a non-add code number such as a customer reference number within a maximum of 16 digits and press the key at any point during the entry of a sale.

■ Refund sales mode

This function can be used only for those item return entries relating to departments and PLUs/UPCs. Pressing the **REFUND SALE** key at the beginning of a transaction causes the register to enter the REFUND SALES mode.

All of the REFUND SALES mode entries are automatically handled as refund entries. This mode cannot be finalized by the check payment entry.

■ Group discount entries

- Your register provides the percent (discount/premium) calculation for three types of group.
- Percentage: 0.01 to 100.00%

Procedure

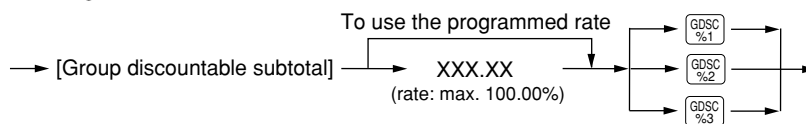

● Group discount status shift

Your register allows you to shift the programmed group discount status of each dept., PLU, UPC, ⊖1 thru ⊖5, percent by pressing the **GD1 SFT**, **GD2 SFT**, and/or **GD3 SFT** keys before those keys. After each entry is completed, the programmed group discount status of each key is resumed.

■ Remote printer send function

This function enables a partial order to be sent to the kitchen for preparation while the remaining order is still being placed.

Procedure

Item entry →  → Data transfer to the remote printer

Remaining items will be sent to the remote printer when the transaction is finalized.

When this function is used, the subtotal void operation is not allowed.

■ Gratuity

Calculation

When the payment operation is made for sales registrations, the gratuity amount is always calculated and printed.

You can program a percent rate for calculating the gratuity.

If the percent rate is programmed as 0%, the POS terminal does not print any gratuity.

You can program a tax status (taxable 1/taxable 2/taxable 3/taxable 4/non-taxable) for gratuity.

Exemption

Your POS terminal allows you to exempt a customer from the gratuity by pressing the  key prior to a payment operation.

Payment Treatment

■ Tip-in entries

Your POS terminal allows the entry of tips that your guests give to servers in cash or by credit card.

A tip entry should be done before a payment entry.

You must use the corresponding media key e.g. CH1 thru CH9 for the charge tip and CASH 1 thru CASH 5 for the cash tip.

Two different tip-in entry systems are available: the tip amount entry system and the tip percent rate entry system. It depends on how your POS terminal has been programmed which of these systems is used.

Procedure

Tip amount entry system:

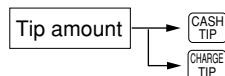

Tip percent rate entry system:

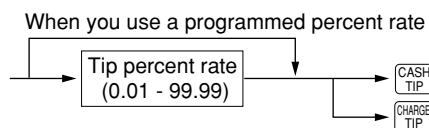

■ Tip editing

This function is used for entering tip amounts after finalizing a guest check transaction. This function is available when the guest check transaction is finalized in a charge tender, and also when the tip is to be paid in charge tender. The bill number which is issued when the **SRVC** or **FINAL** key is pressed in guest check entry must be used in order to identify the guest to edit or add tip amount. For the operation, press the **EDIT TIP** key. When the display prompt appears, enter the bill number and tip amount.

08/27/2002	11:00AM	
123456#2032	JACK0001	
BILL#0016		Bill number
	TBL#1	
COVER CT	2	
***PEAL		\$0.00
DFT. CT	1	\$2.50
BAL FWD		\$2.50
SERVICE		\$2.50

■ Tip paid entries

This operation is used when tips that guests have paid by using credit card are paid to respective servers in cash. To perform a tip paid entry, enter the server code, then press the **TIP PAID** key.

You can prohibit the tip paid operation in the REG mode by the PGM2 programming.

NOTE When the tip amount remains unchanged in Individual Server Resetting, the tip paid function is automatically executed and tip receipt is issued to the report printer prior to report printing.

■ Currency conversion

Your POS terminal allows payment entries in foreign currency. Pressing the **CONV1** thru **CONV4** keys creates a subtotal in foreign currency. Cash alone can be handled after currency conversion.

Procedure

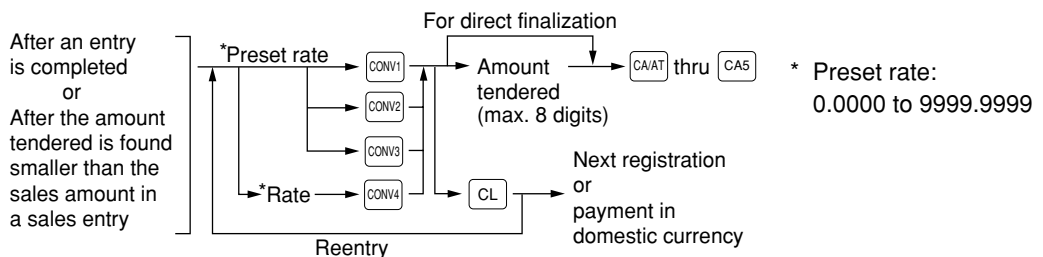

NOTE

- When the amount tendered is short, its equivalent in deficit is shown in domestic currency.
- You can also enter a currency conversion tender from the conversion menu window. Press the **CONV** key and select a pertinent conversion number.
- Change amount will be displayed and printed in domestic currency.

Received-on-account entries

Procedure

Direct key entries

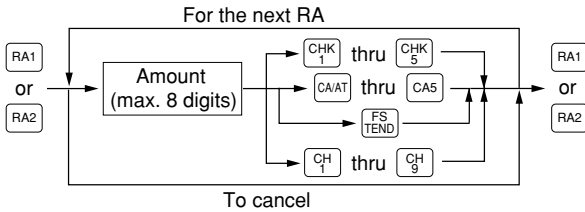

Menu-based entries

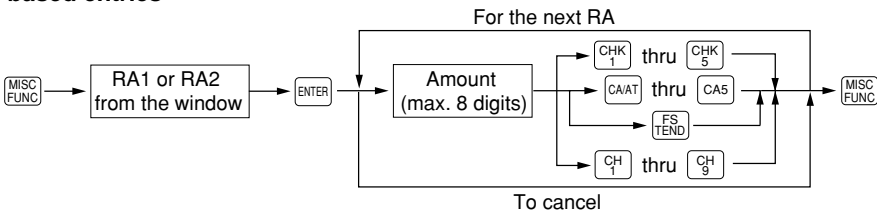

NOTE

You may also choose the RA procedure instead of the above procedure only for cash payment. Contact your authorized SHARP dealer to change the procedure.

Procedure

Direct key entries

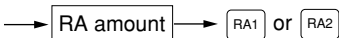

Menu-based entries

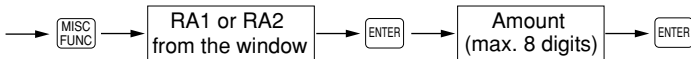

Paid-out entries

Procedure

Direct key entries

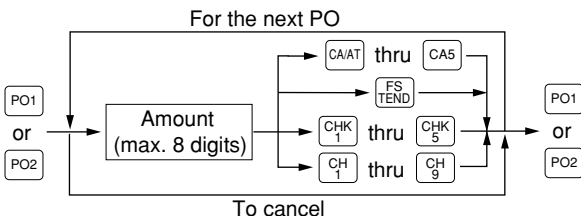

Menu-based entries

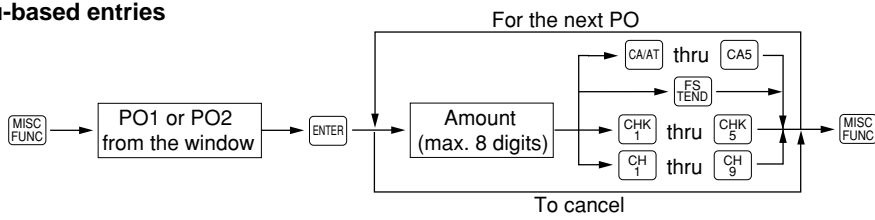

NOTE

You may also choose the PO procedure instead of the above procedure only for cash payment. Contact your authorized SHARP dealer to change the procedure.

Procedure

Direct key entries

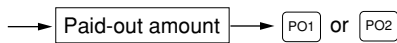

Menu-based entries



■ No-sale (exchange)

Simply press the **NS** key without any entry. The drawer will open and the printer will print a receipt indicating the “NO SALE.” If your POS terminal is programmed to allow a non-add code entry and you enter a non-add code number before pressing the **NS** key, a no-sale entry will be achieved with a non-add code number printed.

NOTE

You can also enter “No-sale” from the miscellaneous menu window. Press the **MISC FUNC** key and select “11 NO SALE” from the window.

■ Cashing a check

Enter the check amount, then press the **CHK 1** thru **CHK 5** keys.

Procedure

Direct key entries

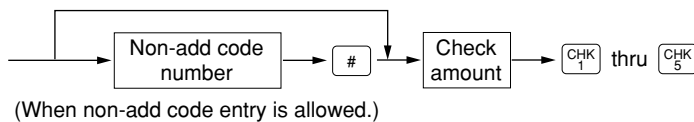

Menu-based entries

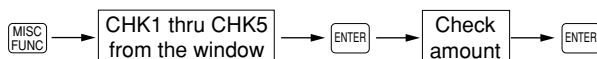

■ Customer management

Your POS terminal can provide the customer management function.

To enable the customer management function, enter the customer code assigned to a customer. You can enter the customer code at any point during a transaction.

Normally customer information (name, code and address) are previously set by the programming. However, you can enter a new customer information during transaction. When an undefined customer code is entered, the message, "UNDEFINED CODE" is displayed, then you can enter the customer's name and address, which are saved in the customer file.

For the customer registered, you can allow to defer his/her payment. Take the tentative finalization using the **CH** key. The sales amount is accumulated to the charge amount of each customer. When the customer settles his/her charge account take the received-on account entry.

Procedure

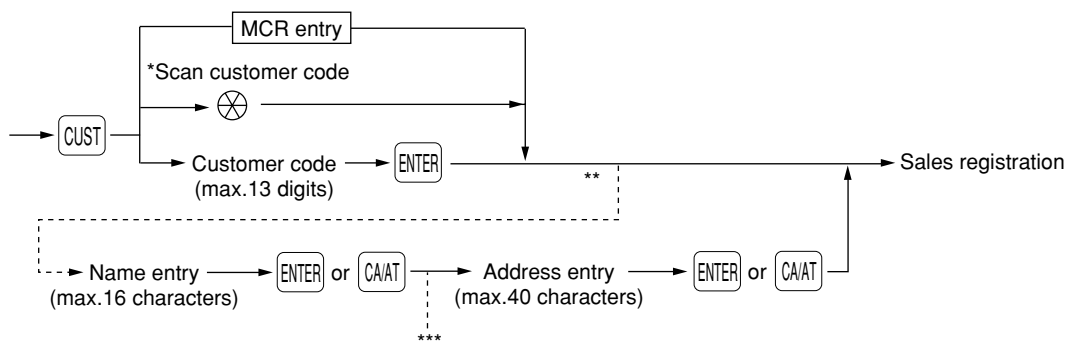

- *: Scanning the customer code on a Customer Card provided to the customer, or EAN-13 format bar code. Additionally the customer code can be read by the optional magnet card reader.
- ** : When a code entered for the customer entry does not exist in the customer file, "UNDEFINED CODE" is displayed for a moment with beep sounds. Then the NAME entry window is displayed to prompt to operator to enter a customer's name.
- ***: The ADDRESS entry window is displayed.

NOTE

- The customer code entry is inhibited after the payment operation.
- When the wrong code is registered, take the following procedure to cancel it.
If no item has been entered, press the **NS** key.
If the item entry has been made, perform the subtotal void operation.

WASTE mode

This mode is used to throw away an article which has already been prepared and is no longer serviceable.

Procedure

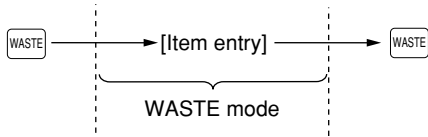

NOTE

- *PLU entries are only allowed in the WASTE mode, and direct and indirect void operations are also allowed in this mode.*
- *When a WASTE-mode transaction is finalized, the drawer does not open.*
- *The consecutive number is incremented every WASTE-mode transaction.*
- *When the WASTE mode is activated by pressing the  key, the mode caption "WASTE" is displayed.*

6

Correction

REG MODE

MGR MODE

Correction of the Last Entry (Direct Void)

If you make an incorrect entry relating to a department, PLU/subdepartment, UPC, percentage (⊖1 thru ⊖5), discount (⊖1 thru ⊖5), manual tax, or tip, you can void this entry by pressing the VOID key immediately.

Example

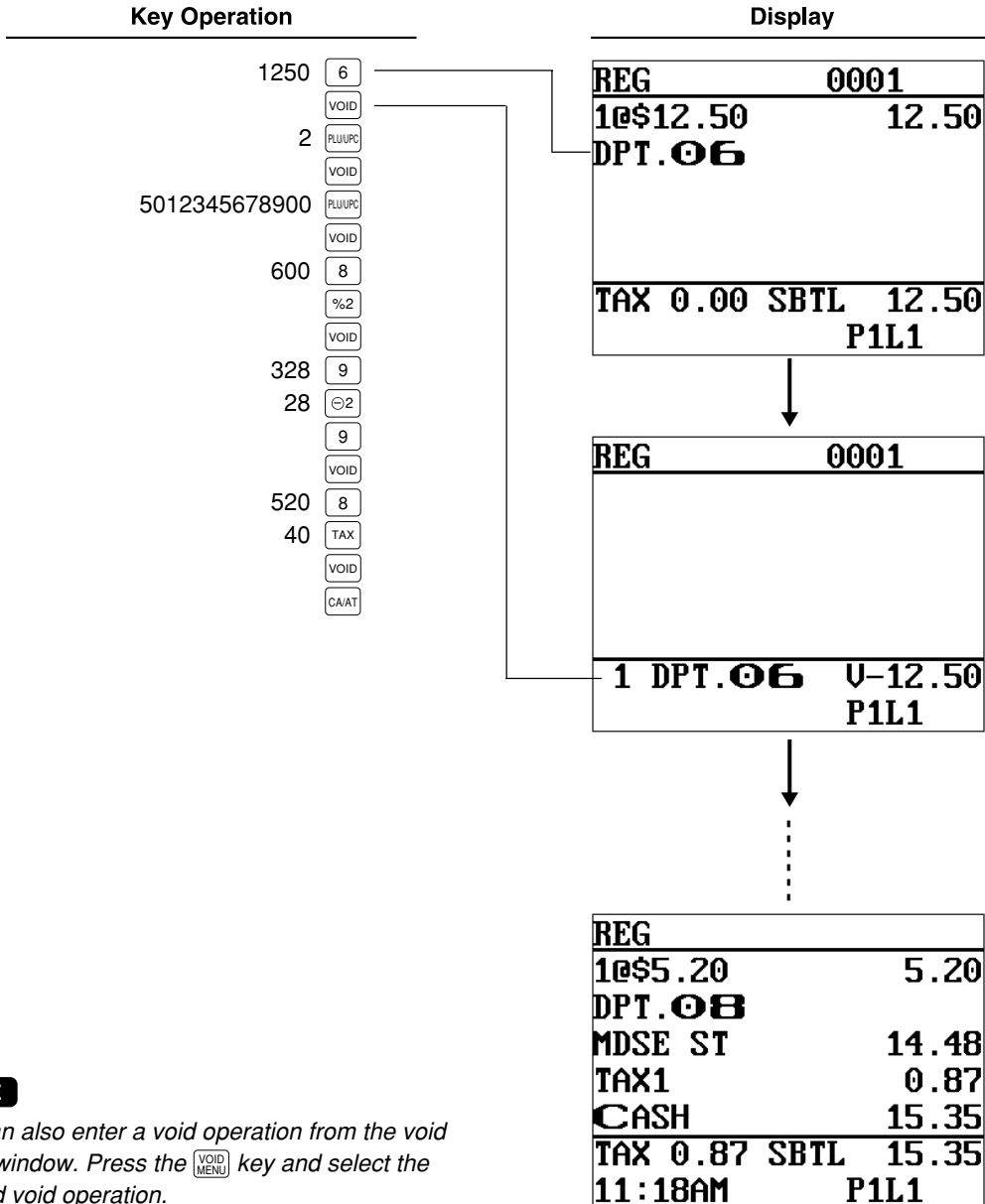

NOTE

You can also enter a void operation from the void menu window. Press the VOID MENU key and select the desired void operation.

Correction of the Next-to-Last or Earlier Entries (Indirect Void)

With the **PAST VOID** key you can void any incorrect department, PLU/subdepartment, UPC or item refund entry made during a transaction if you find it before finalizing the transaction (e.g. before pressing the **CAIAT** key). This function is applicable to department and PLU/subdepartment, UPC and item refund entries only.

Example

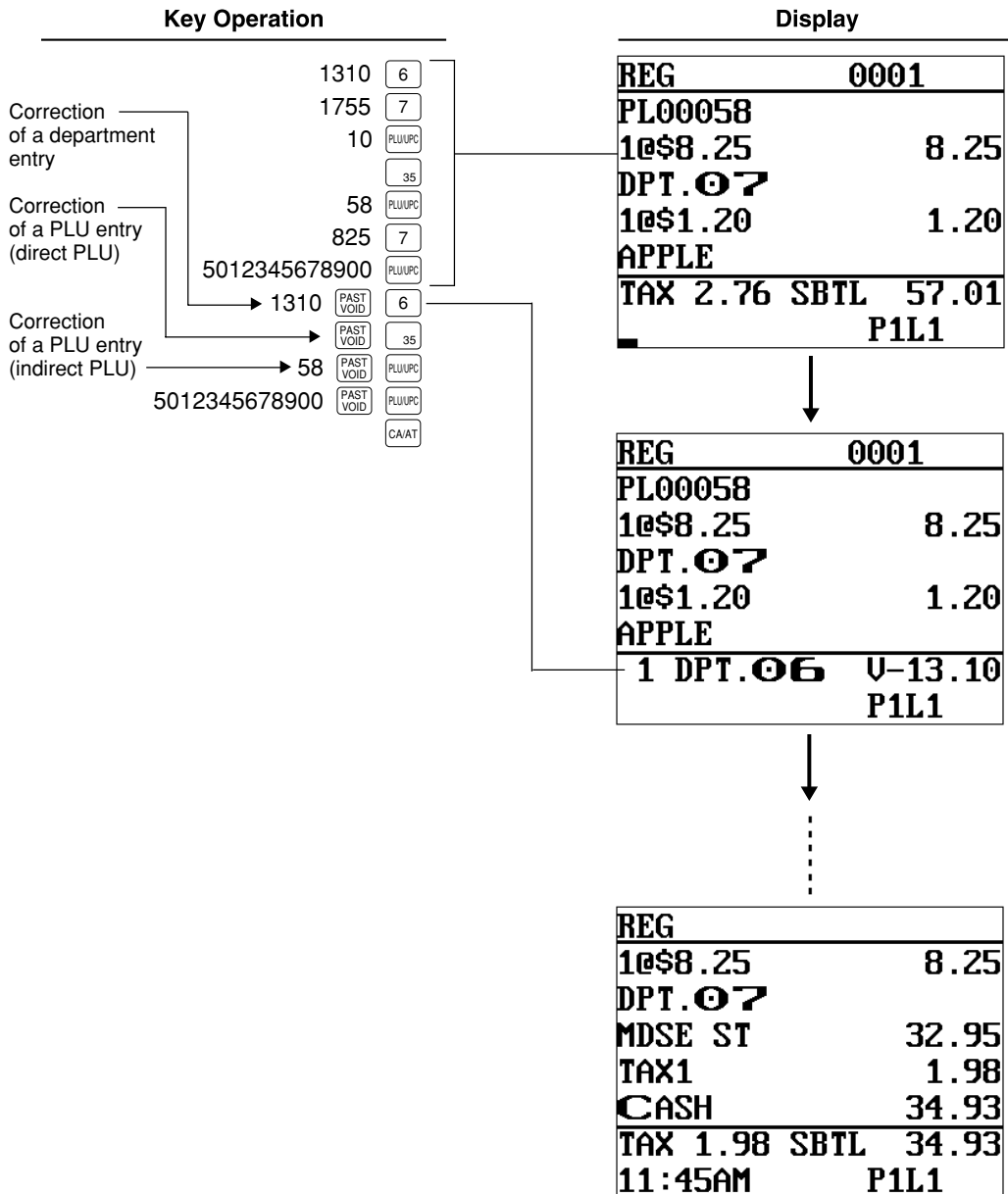







NOTE

- To void entries that include a tax status shift, press the **TAX1 SHIFT**, **TAX2 SHIFT**, **TAX3 SHIFT**, and/or **TAX4 SHIFT** keys prior to the **PAST VOID** key.
- You can also enter a void operation from the void menu window. Press the **VOID MENU** key and select the desired void operation.

Subtotal Void

With the  key you can void an entire transaction. Once the subtotal void is executed, the transaction is canceled and the POS terminal issues a receipt.

Example

Key Operation	Display
1310 	REG
1755 	1@ \$2.00 2.00
10 	PL00035
35 	MDSE ST 39.80
	SBTL VD -39.80
	***TOTAL 0.00
	TAX 0.00 SBTL 0.00
	11:47AM P1L1

NOTE

You can also enter a void operation from the void menu window. Press the  key and select the desired void operation.

Correction of Incorrect Entries Not Handled by the Direct or Indirect Void Function

Any errors found after the entry of a transaction has been completed or during an amount tendered entry, cannot be voided. These errors must be handled by the manager.

The following steps should be taken.

1. If you are making an amount tendered entry, finalize the transaction.
2. Hand the incorrect receipt to your manager for recording purposes.

7

Special Printing Functions

REG MODE

Printing Message Text for Remote Printer or Chit Receipts

You can print a message to remote printers or the chit receipt when programmed. Press the **MSG#** key and select pertinent message number, or press a **MSG₁** thru **MSG₅** keys while item entries. The message will be printed in double sized characters together with items.

NOTE

You can not finalize the transaction under the state that a message only is entered. When multiple messages are entered, the last message only is printed.

Copy Receipt Printing

If your customer wants a receipt after you have finalized a transaction with the receipt ON-OFF function in the "OFF" status (no receipting), press the **RCPT** key. This will make a copy receipt. Your POS terminal can also print a copy receipt when the receipt ON-OFF function is in the "ON" status.

NOTE

To toggle the receipt ON-OFF status, use one of the following procedures:

- Select "01 RCP S.W." from the window which is opened by pressing the **MISC FUNC** key.
- Press the **RCP SW** key to open the "RCP S.W." window.

Example

Printing a copy receipt after making the entries shown below with the receipt ON-OFF function "OFF" status

Key Operation	Print																
<div style="display: flex; align-items: center; gap: 10px;"> <div style="text-align: center;"> <div style="border: 1px solid black; width: 20px; height: 20px; display: flex; align-items: center; justify-content: center; margin: 2px;">2</div> <div style="border: 1px solid black; width: 20px; height: 20px; display: flex; align-items: center; justify-content: center; margin: 2px;">3</div> <div style="border: 1px solid black; width: 20px; height: 20px; display: flex; align-items: center; justify-content: center; margin: 2px;">CA/AT</div> </div> <div style="font-size: 2em; vertical-align: middle;">}</div> <div style="text-align: right; vertical-align: middle;">Print on the journal</div> </div>	<div style="border: 1px solid black; padding: 5px; width: fit-content;"> <table border="0" style="width: 100%; font-family: monospace;"> <tr><td>08/27/2002</td><td>10:39AM</td></tr> <tr><td>123456#2016</td><td>JACK0001</td></tr> <tr><td></td><td>3 @ \$3.32</td></tr> <tr><td>PL00003-1</td><td>\$9.96</td></tr> <tr><td>MDSE ST</td><td>\$12.76</td></tr> <tr><td>TAX1</td><td>\$0.77</td></tr> <tr><td>CASH</td><td>\$13.53</td></tr> </table> </div>	08/27/2002	10:39AM	123456#2016	JACK0001		3 @ \$3.32	PL00003-1	\$9.96	MDSE ST	\$12.76	TAX1	\$0.77	CASH	\$13.53		
08/27/2002	10:39AM																
123456#2016	JACK0001																
	3 @ \$3.32																
PL00003-1	\$9.96																
MDSE ST	\$12.76																
TAX1	\$0.77																
CASH	\$13.53																
<div style="display: flex; align-items: center; gap: 10px;"> <div style="text-align: center;"> <div style="border: 1px solid black; width: 20px; height: 20px; display: flex; align-items: center; justify-content: center; margin: 2px;">RCPT</div> </div> <div style="font-size: 2em; vertical-align: middle;">}</div> <div style="text-align: right; vertical-align: middle;">Print on the receipt</div> </div>	<div style="border: 1px solid black; padding: 5px; width: fit-content;"> <table border="0" style="width: 100%; font-family: monospace;"> <tr><td>08/27/2002</td><td>10:39AM</td></tr> <tr><td>123456#2016</td><td>JACK0001</td></tr> <tr><td></td><td>3 @ \$3.32</td></tr> <tr><td>PL00002-1</td><td>\$2.80</td></tr> <tr><td>PL00003-1</td><td>\$9.96</td></tr> <tr><td>MDSE ST</td><td>\$12.76</td></tr> <tr><td>TAX1</td><td>\$0.77</td></tr> <tr><td>CASH</td><td>\$13.53</td></tr> </table> </div>	08/27/2002	10:39AM	123456#2016	JACK0001		3 @ \$3.32	PL00002-1	\$2.80	PL00003-1	\$9.96	MDSE ST	\$12.76	TAX1	\$0.77	CASH	\$13.53
08/27/2002	10:39AM																
123456#2016	JACK0001																
	3 @ \$3.32																
PL00002-1	\$2.80																
PL00003-1	\$9.96																
MDSE ST	\$12.76																
TAX1	\$0.77																
CASH	\$13.53																

The "COPY" symbol is printed on the copy receipt.

08/27/2002	10:39AM
123456#2016	JACK0001
COPY	
PL00002-1	\$2.80
3 @	\$3.32
PL00003-1	\$9.96
MDSE ST	\$12.76
TAX1	\$0.77
CASH	\$13.53

Validation Printing Function

Your POS terminal can print a validation on checks, coupons, refunds, etc.

■ Validation slip setting and printing

Insert a validation slip into the printer with its printing side downward (see the figure below), then press the

 key.

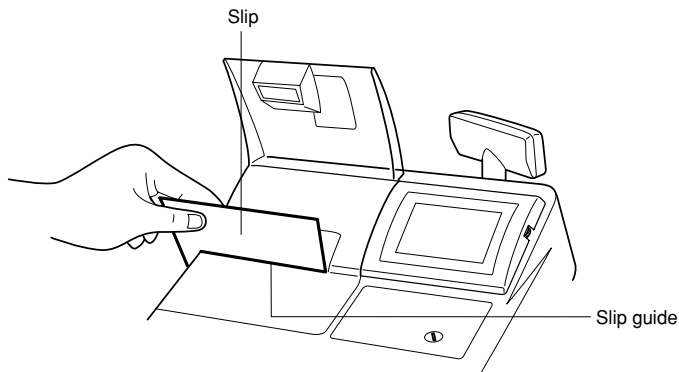

NOTE The validation slip does not reach the bottom of the validation slit. Insert the slip securely until it stops. A validation will correctly be printed on it.

■ Validation printing examples

Validation printing of item entries

Example

- Department entry

08/27/2002	11:21AM	#2052	0001	DPT.06	\$12.50
Date	Time	Consecutive no.	Server code	Item label	Amount

123456	11:29AM	#2054	0001	DPT.06	\$12.50
Register no.	Time	Consecutive no.	Server code		

(Selected by programming)

- PLU entry

08/27/2002	11:37AM	#2058	0001	PL00010	\$12.00
------------	---------	-------	------	---------	---------

- Discount entry (⊖1 thru ⊖5)

08/27/2002	11:37AM	#2058	0001	<->2	-0.65
------------	---------	-------	------	------	-------

- Refund entry

08/27/2002	11:37AM	#2058	0001	DPT.06	R-12.36
------------	---------	-------	------	--------	---------

- Item percent entry (%1 thru %5)

08/27/2002	11:37AM	#2058	0001	%1	-1.50
------------	---------	-------	------	----	-------

- Void entry

```

08/27/2002 11:37AM #2058 0001 DPT.07      V-5.00
  
```

Validation printing after the finalization of a transaction

```

08/27/2002 11:47AM #2060 0001 ***TOTAL      $25.00
  
```

Transaction symbol Amount

CAAT thru **CA5** key

- When an amount tendered entry is made
- When no amount tendered entry is made

CHK thru **CH5** key

- When an amount tendered entry is made
- When no amount tendered entry is made
- When a check cashing operation is made

CH thru **CH9** key

RA1 key

RA2 key

PO1 key

PO2 key

Transaction symbol

*** TOTAL
CASH thru CASH5

CHECK1 thru CHECK5
CHECK1 thru CHECK5
CA/CHK1 thru CA/CHK5
CHARGE1 thru CHARGE9

*** RA
*** RA2
*** PO
*** PO2

Amount

Sales amount
Sales amount

Amount tendered
Sales amount
Amount tendered
Sales amount

Amount received on account
Amount received on account
Amount paid out
Amount paid out

Validation printing of the training mode

```

08/27/2002 11:49AM #2062 0001TRCASH      $25.00
  
```

Training mode symbol

NOTE

• Programmed compulsory validation printing can be overridden by performing the following operation. If you need this function, consult your dealer.

1. Turn the mode switch to the "MGR" position.

2. → [•] → [PRINT]

■ Validation slip specification

Make validation slips according to the following specification. The use of any slips other than specified causes the printer to malfunction.

- Type of paper: plain paper
- Paper thickness: 0.0028 to 0.0055 in. (0.07 to 0.14 mm) thick
- Paper width: over 5.12 in. (130 mm)
- Print position

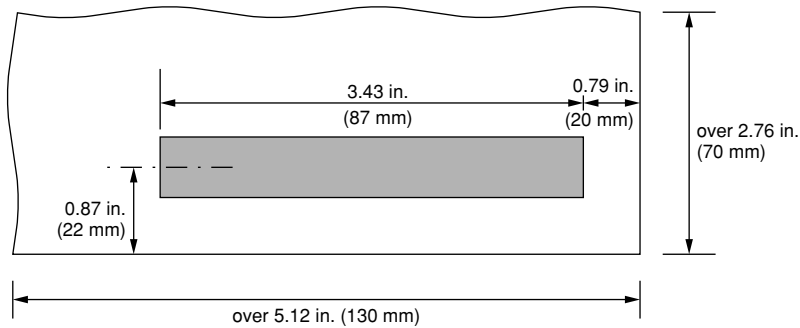

Server Arrival/Departure Time Printing

Your POS terminal allows the server to print the employee arrival and departure times, etc. using the validation printing function.

1. Turn the mode switch to the REG position.
2. Put a card into the paper chute and perform the following key operation.

- Arrival time (printed on the receipt)
Numeric key 1 →
- Departure time (printed on the journal)
Numeric key 2 →

3. Sample printout

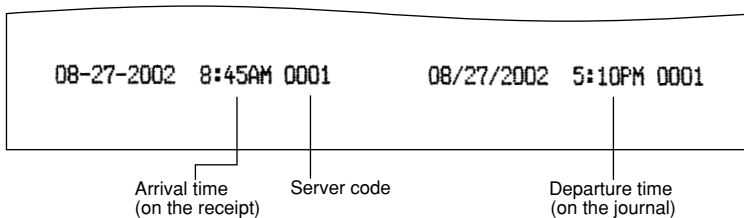

8

Manager Mode

MGR MODE

The MGR mode is used when managerial decisions must be made concerning POS terminal entries, for example, for overriding limitations and for other various entries requiring managerial approval.

NOTE

The normal POS terminal operations may also be performed in this mode. However, a receipt is issued whether the receipt function is ON or OFF.

Override Entries

Programmed limits (such as maximum amounts) for functions can be overridden by placing the POS terminal in the MGR mode.

Example

Selling a \$15.00 item (PLU code 9) for cash and subtracting the coupon amount \$2.50 from the sales amount (This example presumes that the POS terminal has been programmed not to allow coupon entries over \$2.00.)

Key Operation	Display
REG-mode entries	REG
1500 <input type="text" value="9"/>	1@-2.50 -2.50
250 <input type="text" value="2"/> <input type="text" value="9"/> Error	PL00009
<input type="text" value="CL"/>	MDSE ST 12.50
Enter the MGR mode 250 <input type="text" value="2"/> <input type="text" value="9"/>	TAX1 0.90
Return to the REG mode <input type="text" value="CAAT"/>	CASH 13.40
	TAX 0.90 SBTL 13.40
	12:08PM P1L1

9

Correction after Finalizing a Transaction

MGR MODE

When you need to void incorrect entries that servers or cashiers cannot correct (incorrect entries that are found after finalizing a transaction or cannot be corrected by direct or indirect void), follow this procedure in the MGR mode.

1. Turn the mode switch to the MGR position.
2. Press the **VOID** key to put your POS terminal in the VOID mode. (Note the indication on the display.)
3. Repeat the entries that are recorded on an incorrect receipt. (All data in the incorrect receipt is removed from POS terminal memory; the voided amounts are added to the void mode totalizer.)

Incorrect receipt		Cancellation receipt	
08/27/2002	10:45AM	08/27/2002	10:46AM
123456#2018	JACK0001	123456#2018	JACK0001
		VOID	
PL00005-1	\$3.20	PL00005-1	\$3.20
PL00003-1	\$3.32	PL00003-1	\$3.32
MDSE ST	\$6.52	MDSE ST	\$6.52
TAX1	\$0.39	TAX1	\$0.39
CASH	\$6.91	CASH	\$6.91

NOTE

Your POS terminal leaves the VOID mode when a transaction is completed (i.e. finalized in the VOID mode). To void additional transactions, repeat steps **2.** and **3.** above.

Reading (X) and Resetting (Z) of Sales Totals

X1 / Z1 MODE

X2 / Z2 MODE

OPXZ MODE

- Use the reading function (X) when you need to take the reading of sales information entered after the last resetting. You can take this reading any number of times. It does not affect the POS terminal's memory.
- Use the resetting function (Z) when you need to clear the POS terminal's memory. Resetting prints all sales information and clears the entire memory except for GT1 through GT3, reset count, and the consecutive number.
- X1 and Z1 reports show daily sales information. You can take these reports in the X1/Z1 mode.
- X2 and Z2 reports show periodic (monthly) consolidation information. You can take these reports in the X2/Z2 mode.
- If you want to stop the printing of a report, press the key. Even if the printing is stopped, the consecutive number (and Z counter if you are printing a Z report) is increased by one.

■ How to take a X1/Z1 or X2/Z2 reports

[To take a X1 or X2 report:]

1. Place the MA or SM mode key to OP X/Z, X1/Z1, or X2/Z2 position.
2. Select "1 READING" to display the report lists.
3. Select a report title listed in the table shown later. When you select an item with parentheses on the opening screen, you can jump to the associated report title(s).
4. If needed, enter the corresponding values described in the "Data to be entered" column on the table shown later.

[To take a Z1 or Z2 report:]

1. Place the MA or SM mode key to OP X/Z, X1/Z1, or X2/Z2 position.
2. Select "2 RESETTING" to display the report lists.
3. Select a report title listed in the table shown later.
4. If needed, enter the corresponding values described in the "Data to be entered" column on the table shown later.
5. After the report has been taken, the message "ARE YOU SURE ?" will appear.
Select one of the following actions:
 - Select "YES" to reset the sales information.
 - Select "NO" to cancel the report procedure.

■ Flash report

You can take flash reports (display only) in the X1 mode for department sales, cash in drawer (CID) and sales total for a fast view of sales revenue.

1. Place the MA or SM mode key to X1/Z1 position.
2. Select "3 FLASH MODE" to display the flash report menu.
3. Select "DEPT SALES" to take a flash report of department sales, "CID" to take a flash report of cash in drawer, or "SALES TOTAL" to take a flash report of sales total.

Report title	Description	Available report type in each mode		Data to be entered
		X1/Z1	X2/Z2	
1 DEPARTMENT	Department by group	X1, Z1	X2, Z2	Start/end department codes
2 DEPT.IND. GROUP	Individual group total of departments	X1	X2	Department group no.
3 DEPT.GR. TOTAL	Full group total of departments	X1	X2	
4 M-DOWN DEPT.	Department markdown	X1	X2	
5 PLU/UPC	PLU/UPC by designated range	X1, Z1	X2, Z2	Start/end PLU/UPC codes
6 PLU PICK UP	PLU/UPC pick up report	X1, Z1	X2, Z2	*1
7 PLU BY DEPT	PLU/UPC by associated dept.	X1, Z1	X2, Z2	Department code
8 PLU IND. GROUP	Individual group of PLU/UPC	X1	X2	PLU/UPC group no.
9 PLU GR. TOTAL	Full group total of PLU/UPC	X1	X2	
10 PLU STOCK	PLU stock by designated range	X1, Z1		Start/end PLU/UPC codes
11 PLU STOCK PICK UP	PLU/UPC stock pick up report	X1		*1
12 PLU ZERO SALES	PLU/UPC zero sales	X1	X2	All
	PLU/UPC zero sales by department	X1	X2	Department code
13 PLU MIN. STOCK	PLU/UPC minimum stock	X1		Start/end PLU/UPC codes
14 PLU CATEGORY	PLU/UPC by price category	X1	X2	Price
15 DYNAMIC UPC	Dynamic UPC by designated range	X1, Z1	X2, Z2	Start/end UPC codes
16 D-UPC PICK UP	Dynamic UPC pick up report	X1, Z1	X2, Z2	*1
17 D-UPC BY DEPT	Dynamic UPC by associated dept.	X1, Z1	X2, Z2	Department code
18 TRANSACTION	Transaction	X1, Z1	X2, Z2	
19 CID	Cash in drawer	X1	X2	
20 POSITIVE CHECK	Positive check	X1, Z1		
21 KEY CAPTURE	Key capture report	X1		
22 TAX	Tax	X1	X2	
23 ALL SERVER	Full server	X1, Z1	X2, Z2	
24 IND. SERVER	Individual server	X1, Z1	X2, Z2	
		(OP X/Z mode)	X, Z	

Report title	Description	Available report type in each mode		Data to be entered
		X1/Z1	X2/Z2	
25 HOURLY	Hourly (full)	X1, Z1		Start/end time
	Hourly (by range)	X1		
26 DAILY NET	Daily net		X2, Z2	
27 GLU	GLU	X1, Z1		Start/end GLU code
28 GLU BY SERVER	GLU by server	X1, Z1		
29 CLOSE GLU	Closed GLU	X1, Z1		Start/end GLU code
30 CL-GLU BY SERVER	Closed GLU by server	X1, Z1		
31 CUSTOM SALES1	Customer sales 1		X2, Z2	Start/end customer codes
32 CUSTOM SALES2	Customer sales 2		X2, Z2	Start/end customer codes
33 CUSTOM BY AMT	Customer by designated sales range		X2	Amount
34 CHARGE ACCOUNT	Customer charge account		X2	
35 STACKED REPORT	Stacked report 1	X1, Z1	X2, Z2	
	Stacked report 2	X1, Z1	X2, Z2	

NOTE 1: You can pick up PLU/UPC codes for issuing the report. You can pick up new PLU/UPC codes or the codes that were picked up the last time. To pick up new codes, select "1 NEW PICK UP", and follow the procedure show below to pick up new codes. To pick up the codes that were picked up last time, select "2 LAST PICK UP".

Follow the below procedure for picking up PLU/UPC codes.

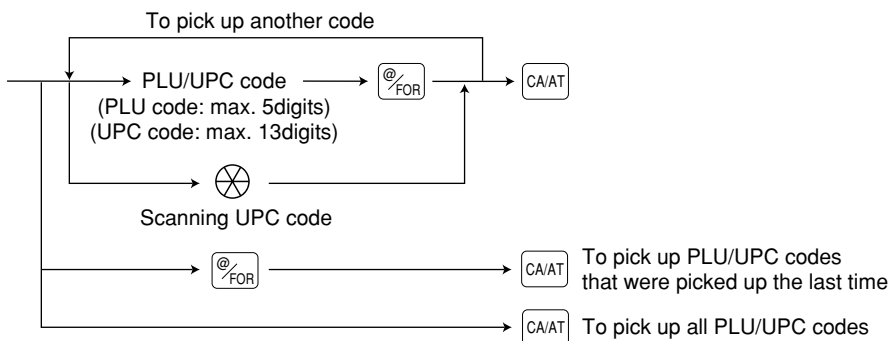

* The following reports relating to PLU/UPC is issued in the following sequence.
 PLU, PLU BY DEPT, PLU IND. GROUP, PLU ZERO SALES, PLU STOCK, PLU MIN. STOCK and PLU CATEGORY
 Also the UPC codes are printed in the sequence shown below.

UPC-A
UPC-E
EAN-13
EAN-8

Daily Sales Totals

Transaction report

Sample X report

08/26/2002	9:20PM		
123456#1622	JACK0001		
#0130	%Z1%		
TRANSACTION			
TR	\$00000000	176.89	
(-)>1	3Q	-3.45	
(-)>2	3Q	-4.36	
ST(-)	TL	6Q	-7.81
%1	4Q	-20.78	
%2	3Q	-11.23	
ST % TL	7Q	-32.01	
GDISC%1	2Q	-78.03	
GDISC%2	2Q	-148.12	
GDISC%3	2Q	-187.65	
GDISC%TL	6Q	-413.80	
GAS(-)1	1Q	-9.84	

GAS(-)19	1Q	-41.40	
GASDISTL	3Q	-63.40	
NET 1		\$9565.24	
TAX1 ST		\$1146.49	
GRS TAX1		\$69.57	
RFD TAX1		-0.78	
TAX1		\$68.79	
TX1 EXPT		\$25.11	

TAX4 ST		\$1137.93	
GRS TAX4		\$61.77	
RFD TAX4		-0.26	
TAX4		\$61.51	
TX4 EXPT		\$51.18	
GRS MTAX		\$7.10	
RFD MTAX		-1.16	
M-TAX		\$5.94	
FS TX1		\$0.00	
FS TX2		\$0.00	
FS TX3		\$0.00	

TTL TAX		\$230.75	
NET		\$9452.48	
NET2		\$9683.23	
COMED1	5Q	\$25.50	

Sample Z report

08/26/2002	11:01PM		
123456#1815	JACK0001		
#0130	%Z1%		
TRANSACTION			
TRANS. Z1		0013	
GT1	\$00000027	423.37	
GT2	\$00000028	440.46	
GT3	-00000001	017.09	
TR	\$00000000	249.14	

The subsequent printout occurs in the same format as in the sample X report.

(When the Canadian tax system is selected)

TAX1 ST	\$1146.49	
GRS TAX1	\$69.57	
RFD TAX1	-0.78	
TAX1	\$68.79	
TX1 EXPT	\$25.11	
TAX2 ST	\$1081.28	
GRS TAX2	\$43.44	

TAX4 ST	\$1137.93	
GRS TAX4	\$61.77	
RFD TAX4	-0.26	
TAX4	\$61.51	
TX4 EXPT	\$51.18	
GRS MTAX	\$7.10	
RFD MTAX	-1.16	
M-TAX	\$5.94	
GST EXPT	\$2355.92	
PST TTL	\$163.30	
GST TTL	\$61.51	

To be continued on the next page

COMB020	00	\$0.00	
<->3	80	-12.08	(-)3 counter and total (Item(-))
<->4	80	-13.84	
<->5	90	-12.24	
(-) TL	250	-38.16	Total for item(-)
%3	120	-5.09	%3 counter and total (Item %)
%4	130	-4.44	
%5	110	-6.41	
% TL	360	-15.94	Total for item %
CP PLU	80	-13.50	Coupon-like PLU counter and total
V.CP UPC	00	\$0.00	Vender coupon UPC counter and total
EAT IN 1	20	\$52.42	Eat-in 1 counter and total
EAT IN 2	20	\$36.89	
EAT IN 3	20	\$25.10	
DIR VD	80	\$17.15	Direct void counter and total
PAST VD	60	\$59.30	Indirect void counter and total
SBTL VD	20	\$22.76	Subtotal void counter and total
MGR VD	30	\$8.75	Manager item void counter and total
VOID	10	\$8.74	Void-mode transaction counter and total
REFUND	500	\$313.16	Refund counter and total
RETURN	20	\$7.43	Return counter and total
HASH VD	50	\$9.44	Hash item void counter and total
HA P.VD	10	\$8.15	Hash item indirect void
HASH RF	20	\$3.73	Hash item refund counter and total
HASH RT	20	\$5.32	Hash item return counter and total
NO SALE	60		No-sale (exchange) counter
VP CNT	00		Validation print counter
BILL CNT	00		Bill print counter
DRW CNT	480		Till timer counter
TRAY CNT	80		Tray subtotal print counter
***PBAL	60		GLU/PBLU counter
SERVICE	30		Service counter (for GLU/PBLU)
COVER CT			Cover counter
	1490		
TRAN.OUT	10	\$26.75	Transfer-out counter and total
TRAN.IN	10	\$26.75	Transfer-in counter and total
TRANS CT			Transaction counter
	1230		
AVE SALE		\$64.99	
GRATUITY		-6.79	Gratuity total
NET3		\$9810.67	Sales total (including hash dept. total)
HASH TTL	100	\$56.58	Hash counter and total
WASTE TL	100	-33.40	Waste counter and total
CASH	600	\$8390.87	Cash counter and total
CASH2	30	\$61.77	Cash 2 counter and total

To be continued on the next page

CASH5	2Q	\$26.33	
CASH TL	69Q	\$8575.19	Total for cash
FS SALE	4Q	\$132.24	
XXXRA	3Q	\$230.00	Received-on-account counter and total
XXXRA2	2Q	\$130.00	
RA TL	5Q	\$360.00	Total for received-on-account
XXXPD	1Q	\$60.00	Paid-out counter and total
XXXPD2	1Q	\$30.00	
PD TL	2Q	\$90.00	Total for paid-out
CA/CHK1	1Q	\$15.00	Check cashing 1 counter and total
CA/CHK2	1Q	\$12.00	
CA/CHK3	1Q	\$50.00	
CA/CHK4	2Q	\$31.00	
CA/CHK5	1Q	\$80.00	
CA/CK TL	6Q	\$188.00	Total for check cashing
CHK/CG		\$16.88	Cash change total for check and charge 1-9 tendering
FS CG		\$1.76	
CONV 1		130.00	Currency conversion 1 total (by programmed rate)
CONV 2		100.00	
CONV 3		120.00	
CONV 4		70.00	Currency conversion 4 total (by manual rate)
CONV TL		420.00	Total for conversion
FS ID		\$134.00	
CHARGE1	6Q	\$209.48	Gross charge 1 counter and total
CHARGE1-	1Q	-13.14	Refund charge 1 counter and total
CHARGE2	3Q	\$105.80	
CHARGE2-	2Q	-36.62	

CHARGE8	8Q	\$242.67	
CHARGE8-	1Q	-35.97	
CHARGE9	4Q	\$159.60	
CHARGE9-	1Q	-7.88	
CHR TL	45Q	\$881.72	Total for charge
CHECK1	4Q	\$83.00	Check 1 sale counter and tendering counter
CHECK2	1Q	\$42.00	
CHECK3	1Q	\$70.00	
CHECK4	1Q	\$56.00	
CHECK5	1Q	\$100.00	
CHECK TL	8Q	\$351.00	Total for check
CA+CH ID		\$8698.51	Cash+check in drawer
***CID		\$8347.51	Cash in drawer
DEPOSIT	1Q	\$50.00	Deposit counter and total
DPST RF	1Q	-50.00	Deposit refund counter and total
TIP PAID	2Q	\$27.00	Tip-paid counter and total
CA TIP	1Q	\$12.00	Cash tip-in counter and total
CH TIP	1Q	\$15.00	Charge tip-in counter and total

Department report

• Sample X report

```

08/26/2002    9:33PM
123456#1625   JACK0001

#0110 %X1%
DEPARTMENT

D01 43270    56.97%
DPT.01      $15001.57
    
```

Dept. code
Sales q'ty
Dept. label
Sales amount

• Sample Z report

```

08/26/2002    11:05PM
123456#1818   JACK0001

#0110 %Z1%
DEPARTMENT

DEPARTMENT Z1    0004
    
```

Reset counter

The subsequent printout occurs in the same format as in the sample X report.

```

D13 6Q    0.12%
DPT.13    $31.26
%DEPT TL
63110    $26332.02
100.00%

D16 3Q    -9.63
DPT.16    -9.63
DEPT(-) 3Q    -9.63

D17 7Q    $67.11
DPT.17    $67.11
%HASH TL 7Q    $67.11

D18 3Q    -10.53
DPT.18    -10.53
HASH(-) 3Q    -10.53

D19 5Q    $7.50
DPT.19    $7.50
%B TTL TL 5Q    $7.50

D20 11Q   -6.10
DPT.20    -6.10
B TTL(-) 11Q   -6.10

D14 10Q    114
DPT.14    $267.41
%GAS TL 10Q    114
$267.41

D15 3Q    0
DPT.15    -7.53
GAS(-) 3Q    0
-7.53
    
```

Ratio of dept. 3 sales amount to "+" real dept. total
 "+" real dept. counter and total
 "-" real dept. counter and total
 "+" hash dept. counter and total
 "-" hash dept. counter and total
 "+" bottle return dept. counter and total
 "-" bottle return dept. counter and total
 "+" gasoline dept. counter/gasoline q'ty/total
 "-" gasoline dept. counter/gasoline q'ty/total

Individual group total report on departments

08/26/2002	9:37PM	
123456#1628	JACK0001	
#0112 *X1*		
DEPT.IND.GROUP		
D02	1725Q	
DPT.02		\$6549.26
D03	136Q	
DPT.03		\$554.26
DPT GR-1		
	1861Q	\$7103.52

Dept. code
Sales q'ty
Sales amount
Dept. label
Group 1 sales q'ty and amount

Department markdown report

08/26/2002	9:40PM	
123456#1638	JACK0001	
#0119 *X1*		
M-DOWN DEPT.		
D01		
DPT.01		
<->3	2Q	-3.02
<->4	4Q	-6.92
<->5	2Q	-2.72
***TOTAL	8Q	-12.66
%3	1Q	-0.62
%4	5Q	-1.70
%5	1Q	-0.56
***TOTAL	7Q	-2.88
D02		
DPT.02		
<->3	2Q	-3.02
<->4	1Q	-1.73
<->5	1Q	-1.36
***TOTAL	4Q	-6.11
%3	6Q	-2.34
%4	2Q	-0.64
%5	2Q	-1.06
***TOTAL	10Q	-4.04
D03		
DPT.03		
<->3	1Q	-1.51
<->4	1Q	-1.73
<->5	4Q	-5.44
***TOTAL	6Q	-8.68
%3	2Q	-0.96
%4	3Q	-1.14
%5	5Q	-3.20
***TOTAL	10Q	-5.30

Dept. code
Dept. label
(-)3 counter and total (Item -)
Item (-) counter and total for dept. 1
%3 counter and total (Item %)
Item % counter and total for dept. 1

Full group total report on departments

08/26/2002	9:39PM	
123456#1633	JACK0001	
#0113 *X1*		
DEPT.GR.TOTAL		
DPT GR-1		
	1861Q	\$7103.52
DPT GR-2		
	4334Q	\$15068.68
DPT GR-3	7Q	\$41.51
DPT GR-4	0Q	\$0.00
DPT GR-5	0Q	\$0.00
DPT GR-6	0Q	\$0.00
DPT GR-7	0Q	\$0.00
DPT GR-8	0Q	\$0.00
DPT GR-9	5Q	\$7.50

Group 1 sales q'ty and amount

■ PLU/UPC report by designated range

• Sample X report

08/26/2002	9:45PM	
123456#1645	JACK0001	
#0120 *X<1*		
PLU/UPC		
	00001-	PLU range
	999999999999	PLU code
PLU	F*00001	Item label for price level 1
	PL00001-1	
	1641Q	Sales q'ty and amount for price level 1
	\$4308.07	
COMBO	4Q	Combo sales for price level 1
	\$5.00	
WASTE	-3Q	
	-7.89	
RF	-4Q	
	-10.52	
CP	16Q	
	-22.82	
NET SLS		Coupon counter and total for price level 1
	1638Q	*1
	\$4271.84	
PL00001-2	3Q	Net sales for price level 1
	\$7.50	
COMBO	1Q	
	\$1.25	
*1 If you need these information, please consult your dealer.		
PL00001-6	5Q	
	\$25.00	
NET SLS	5Q	
	\$25.00	
F*00002		
PL00002-1		
	1793Q	
	\$5017.52	
NET SLS	9Q	
	\$64.35	

***TOTAL		Total sales q'ty and total sales amount for price level 1
	6226Q	\$19314.29
COMBO TL	24Q	\$54.40
WASTE TL		
	-10Q	-33.40
		0.17%
RF TL	-42Q	-225.60
CP	30Q	-44.16
NET TL	6198Q	\$19065.53

RF TL	0Q	\$0.00
CP	0Q	\$0.00
NET TL	7Q	\$41.40

• Sample Z report

08/26/2002	11:06PM	
123456#1819	JACK0001	
#0120 *XZ1*		
PLU/UPC		
PLU/UPC	Z1/Z2	0003

↓
The subsequent printout occurs in the same format as in the sample X report.

UPC		
311111111111#		
ITEM-K-1	2Q	-4.40
NET SLS	2Q	-4.40
ITEM-K-6	1Q	-3.10
NET SLS	1Q	-3.10
3234567891082#		
ITEM-B-1	5Q	\$14.30
NET SLS	5Q	\$14.30
5012345678906#		
ITEM-A-1	6Q	\$15.00
NET SLS	6Q	\$15.00
5045678912304#		
ITEM-D-1	5Q	\$12.50

5087654321106#		
ITEM-F-1	6Q	\$19.20
NET SLS	6Q	\$19.20
ITEM-F-6	2Q	\$6.80
NET SLS	2Q	\$6.80

***TOTAL	24Q	\$56.60
WASTE TL	0Q	\$0.00
		0.00%
RF TL	0Q	\$0.00
CP	0Q	\$0.00
NET TL	24Q	\$56.60

RF TL	0Q	\$0.00
CP	0Q	\$0.00
NET TL	3Q	\$3.70

■ PLU/UPC pick up report

• Sample X report

```

08/26/2002      9:47PM
123456#1647     JACK0001

#0120 *K1*
PLU/UPC

PLU
F-00001
PLO0001-1
1641Q          $4308.07
COMBO 4Q       $5.00
WASTE -3Q      -7.89
RF -4Q         -10.52
CP 16Q         -22.82
NET SLS 1638Q  $4271.84
1638Q          24.51%
PLO0001-2 3Q   $7.50
    
```

PLU code
 Item label for price level 1
 Sales q'ty and amount for price level 1
 Combo sales for price level 1
 Coupon counter and total for price level 1
 Net sales for price level 1

*1
 If you need these information, please consult your dealer.

```

PLO0001-6 5Q   $25.00
NET SLS 5Q     $25.00
                60.39%

F-00002
PLO0002-1
1793Q          $5017.52
    
```

```

NET SLS 1Q     $1.75
                13.89%

-----
***TOTAL
5894Q          $17492.79
COMBO TL 12Q   $20.40
WASTE TL -9Q   -26.25
                0.15%
RF TL -8Q     -21.72
CP 24Q        -35.48
NET TL 5889Q  $17429.74
                100.00%
    
```

Total sales q'ty and total sales amount for price level 1

```

RF TL 0Q       $0.00
CP 0Q          $0.00
NET TL 7Q      $41.40
                100.00%
    
```

• Sample Z report

```

08/26/2002      11:08PM
123456#1821     JACK0001

#0120 *Z1*
PLU/UPC

PLU/UPC Z1/Z2      0004
    
```

The subsequent printout occurs in the same format as in the sample X report.

```

UPC
3234567891082#
ITEM-B-1 5Q     $14.30
NET SLS 5Q     $14.30
                48.81%

5012345678906#
ITEM-A-1 6Q     $15.00
NET SLS 6Q     $15.00
                51.19%

-----
***TOTAL 11Q    $29.30
WASTE TL 0Q    $0.00
                0.00%
RF TL 0Q       $0.00
CP 0Q          $0.00
NET TL 11Q     $29.30
                100.00%

-----
WASTE TL 0Q    $0.00
                0.00%
RF TL 0Q       $0.00
CP 0Q          $0.00
NET TL 0Q      $0.00
                100.00%
    
```

■ PLU/UPC report by associated department

• Sample X report

08/26/2002	9:48PM	
123456#1650	JACK0001	
#0121	*Z1*	
PLU BY DEPT		
DPT.01	001	Associated dept. code
PLU		PLU code
F00002		Item label
PL00002-1		
1793Q	\$5017.52	Sales q'ty and amount for price level 1
COMBO 4Q	\$8.40	
WASTE -3Q	-8.40	
RF -4Q	-11.20	
CP 8Q	-12.66	
NET SLS		
1790Q	\$4993.66	
	36.48%	
PL00002-2 0Q	\$0.00	
PL00002-6 2Q	\$16.40	
NET SLS 2Q	\$16.40	
	100.00%	
F00003		
PL00003-1		
2460Q	\$8167.20	
NET SLS 9Q	\$64.35	
	0.47%	

***TOTAL		Total sales q'ty and total sales amount for price level 1
4324Q	\$13761.27	
COMBO TL 12Q	\$28.20	
WASTE TL -7Q	-25.51	
	0.19%	
RF TL -10Q	-63.58	
CP 8Q	-12.66	
NET TL 4319Q	\$13687.72	
	100.00%	
RF TL 0Q	\$0.00	
CP 0Q	\$0.00	
NET TL 2Q	\$16.40	
	100.00%	

• Sample Z report

08/26/2002	11:10PM	
123456#1823	JACK0001	
#0121	*Z1*	
PLU BY DEPT		
PLU/UPC Z1/Z2	0005	
↓		
The subsequent printout occurs in the same format as in the sample X report.		
UPC		
3234567891082#		
ITEM-B-1 5Q	\$14.30	
NET SLS 5Q	\$14.30	
	31.09%	
5045678912304#		
ITEM-D-1 5Q	\$12.50	
NET SLS 5Q	\$12.50	
	27.17%	
5087654321106#		
ITEM-F-1 6Q	\$19.20	
NET SLS 6Q	\$19.20	
	41.74%	
ITEM-F-6 2Q	\$6.80	
NET SLS 2Q	\$6.80	
	100.00%	

***TOTAL 16Q	\$46.00	
WASTE TL 0Q	\$0.00	
	0.00%	
RF TL 0Q	\$0.00	
CP 0Q	\$0.00	
NET TL 16Q	\$46.00	
	100.00%	
RF TL 0Q	\$0.00	
CP 0Q	\$0.00	
NET TL 2Q	\$6.80	
	100.00%	

Individual group report on PLUs/UPCs

08/26/2002	9:53PM
123456#1661	JACK0001
#0122 *K1*	
PLU IND. GROUP	
PLU	
F*00003	PLU code
PL00003-1	Item label
2461Q	\$8164.24
PL00003-2 2Q	\$4.05
PL00003-3 1Q	\$1.50
PL00003-4 1Q	\$2.80
PL00003-5 1Q	\$2.70
PL00003-6 1Q	\$2.60
F*00004	
PL00004-1 7Q	\$35.70

UPC	
5012345678906#	
ITEM-A-1 7Q	\$17.50
ITEM-A-2 1Q	\$1.25
ITEM-A-3 1Q	\$1.30
ITEM-A-4 1Q	\$1.75
ITEM-A-5 1Q	\$2.10
ITEM-A-6 1Q	\$2.20

PLU GR01	
2486Q	\$8239.69

Sales q'ty and amount for price level 1

Group 1 sales q'ty and amount

PLU/UPC stock report by designated range

08/26/2002	9:55PM
123456#1666	JACK0001
#0124 *K1*	
PLU STOCK	
00001-	
99999999999999	
PLU	
F*00001	PLU code
PL00001-1	Item label
317S	\$833.71
F*00002	
PL00002-1	
253S	\$708.40

F*00020	
PL00020-1	
108S	\$772.20

UPC	
31111111111111#	
ITEM-K-1	
51S	-112.20

5099887654302#	
ITEM-E-1	
21S	\$27.30

Range

Stock q'ty

Full group total report on PLUs/UPCs

08/26/2002	9:54PM
123456#1662	JACK0001
#0123 *K1*	
PLU GR. TOTAL	
PLU GR01	
2486Q	\$8239.69
PLU GR02	
1911Q	\$5385.38

PLU GR99	
1953Q	\$5643.68

Item label

Sales q'ty and amount for PLU group 1

PLU/UPC stock pick up report

08/26/2002	9:57PM
123456#1668	JACK0001
#0124 *K1*	
PLU STOCK	
PLU	
F*00001	
PL00001-1	
317S	\$833.71
F*00002	
PL00002-1	
253S	\$708.40

UPC	
3234567891082#	
ITEM-B-1	
20S	\$57.20

■ PLU/UPC zero sales report (full)

```

08/26/2002    10:02PM
123456#1671   JACK0001

#0127 *3<1*
PLU ZERO SALES

PLU
F00013 PL00013-1
F00014 PL00014-1
F00015 PL00015-1
F00016 PL00016-1
F00017 PL00017-1
-----
UPC
3112345678905#
      ITEM-J-1
322222222221#
      ITEM-U-1
3232109876582#
      ITEM-G-1
355555555551#
      ITEM-Q-1
5089123456708#
      ITEM-C-1
5099887654302#
      ITEM-E-1
    
```

PLU code
Item label

■ PLU/UPC minimum stock report

```

08/26/2002    10:04PM
123456#1675   JACK0001

#0128 *3<1*
PLU MIN.STOCK

          00001-
          999999999999
PLU
F00007
PL00007-1      20S
F00008
PL00008-1      18S
-----
UPC
3234567891082#
ITEM-B-1      15S
    
```

Range
PLU code
Stock q'ty
Item label

■ PLU/UPC zero sales (by dept.) report

```

08/26/2002    10:02PM
123456#1673   JACK0001

#0127 *3<1*
PLU ZERO SALES

DPT.02      D02
PLU
F00014 PL00014-1
-----
UPC
322222222221#
      ITEM-U-1
355555555551#
      ITEM-Q-1
    
```

Associated dept. code
PLU code
Item label

■ PLU/UPC price category report

• Sample X report

08/26/2002	10:12PM	
123456#1686	JACK0001	
#0129	XX1X	
PLU CATEGORY		
	2.00-	2.60
		Price range
PLU		
P-00001		
PLO0001-2	4Q	\$8.75
P-00002		
PLO0002-4	1Q	\$2.60
P-00003		
PLO0003-2	2Q	\$4.05
PLO0003-6	1Q	\$2.60

***TOTAL	0Q	\$0.00
	6Q	\$12.80
	0Q	\$0.00
	1Q	\$2.60
	0Q	\$0.00
	1Q	\$2.60

UPC		
5012345678906#		
ITEM-A-1	7Q	\$17.50
ITEM-A-5	1Q	\$2.10
ITEM-A-6	1Q	\$2.20
5045678912304#		
ITEM-D-1	5Q	\$12.50

***TOTAL	12Q	\$30.00
	0Q	\$0.00
	0Q	\$0.00
	0Q	\$0.00
	1Q	\$2.10
	1Q	\$2.20

■ Cash in drawer report

• Sample X report

08/26/2002	10:21PM	
123456#1718	JACK0001	
#0131	XX1X	
CID		
SRV#0001	JACK	Server code
TRANS CT		Server name
	2074Q	Transaction counter
NET3	\$26734.87	Sales total
XXXXCID	\$25123.76	Cash in drawer
SRV#0002	JIM	
TRANS CT	16Q	

***TOTAL		
TRANS CT	2090Q	Total
NET3	\$27058.97	
XXXXCID	\$25447.86	

■ Positive check report

• Sample X report

08/26/2002	10:22PM	
123456#1721	JACK0001	
#0139	XX1X	
POSITIVE CHECK		
#0000000022331100		
CHECK3	\$60.00	
#0000000055667788		
CHARGE7	\$87.95	

• Sample Z report

08/26/2002	11:15PM	
123456#1828	JACK0001	
#0139	XX1X	
POSITIVE CHECK		
#0000000022331100		
CHECK3	\$60.00	
#0000000055667788		
CHARGE7	\$87.95	

■ Dynamic UPC report by designated range

• Sample X report

08/26/2002	10:15PM		
123456#1692	JACK0001		
#0169	*Z1*		
DYNAMIC UPC			
1000000000000-			
9999999999999			
1123456789005#			
ITM(2)-1	5Q	\$15.85	*1
NET SLS	5Q	\$15.85	
		100.00%	
ITM(2)-6	11Q	\$34.87	*1
NET SLS	11Q	\$34.87	
		100.00%	

***TOTAL	5Q	\$15.85	*1
WASTE TL	0Q	\$0.00	
		0.00%	
RF TL	0Q	\$0.00	*1
CP	0Q	\$0.00	
NET TL	5Q	\$15.85	
		100.00%	
RF TL	0Q	\$0.00	*1
CP	0Q	\$0.00	
NET TL	11Q	\$34.87	
		100.00%	

■ Dynamic UPC pick up report

• Sample X report

08/26/2002	10:16PM		
123456#1694	JACK0001		
#0169	*Z1*		
DYNAMIC UPC			
1123456789005#			
ITM(2)-1	5Q	\$15.85	*1
NET SLS	5Q	\$15.85	
		100.00%	
ITM(2)-6	11Q	\$34.87	*1
NET SLS	11Q	\$34.87	
		100.00%	

***TOTAL	5Q	\$15.85	*1
WASTE TL	0Q	\$0.00	
		0.00%	
RF TL	0Q	\$0.00	*1
CP	0Q	\$0.00	
NET TL	5Q	\$15.85	
		100.00%	
RF TL	0Q	\$0.00	*1
CP	0Q	\$0.00	
NET TL	11Q	\$34.87	
		100.00%	

*1

If you need these information, please consult your dealer.

• Sample Z report

08/26/2002	11:12PM		
123456#1824	JACK0001		
#0169	*Z1*		
DYNAMIC UPC			



The subsequent printout occurs in the same format as in the sample X report.

■ Dynamic UPC report by associated department

- Sample X report

08/26/2002	10:18PM	
123456#1697	JACK0001	
#0166 %X1%		
D-UPC BY DEPT		
DPT.01	DO1	
1123456789005#		
ITM(2)-1	5Q	\$15.85
NET SLS	5Q	\$15.85
		100.00%
ITM(2)-6	11Q	\$34.87
NET SLS	11Q	\$34.87
		100.00%

***TOTAL	5Q	\$15.85
WASTE TL	0Q	\$0.00
		0.00%
RF TL	0Q	\$0.00
CP	0Q	\$0.00
NET TL	5Q	\$15.85
		100.00%
RF TL	0Q	\$0.00
CP	0Q	\$0.00
NET TL	11Q	\$34.87
		100.00%

- Sample Z report

08/26/2002	11:13PM
123456#1825	JACK0001
#0166 %Z1%	
D-UPC BY DEPT	



The subsequent printout occurs in the same format as in the sample X report.

*1

If you need these information, please consult your dealer.

■ Tax report

08/26/2002	10:40PM		
123456#1741	JACK0001		
#0133	XX1*		
TAX			
(When the Canadian tax system is selected)			
TAX1 ST	\$1146.49	Net taxable 1 total	
GRS TAX1	\$69.57	Gross tax 1 total	
RFD TAX1	-0.78	Refund tax 1 total	
TAX1	\$68.79	Net tax 1 total	
TX1 EXPT	\$25.11	Taxable 1 exempt total	
TAX2 ST	\$1081.28		
GRS TAX2	\$43.44		
RFD TAX2	-0.18		
TAX2	\$43.26		
TX2 EXPT	\$44.63		
TAX4 ST	\$1137.93	Gross manual tax total	
GRS TAX4	\$61.77	Refund manual tax total	
RFD TAX4	-0.26	Net manual tax total	
TAX4	\$61.51		
TX4 EXPT	\$51.18		
GRS MTAX	\$7.10		
RFD MTAX	-1.16		
M-TAX	\$5.94		
GST EXPT	\$2355.92		
PST TTL	\$163.30		
GST TTL	\$61.51		
FS TX1	\$0.00		
FS TX2	\$0.00		
FS TX3	\$0.00		
TTL TAX	\$230.75	Tax total	

TAX1 ST	\$1146.49
GRS TAX1	\$69.57
RFD TAX1	-0.78
TAX1	\$68.79
TX1 EXPT	\$25.11

TAX4 ST	\$1137.93
GRS TAX4	\$61.77
RFD TAX4	-0.26
TAX4	\$61.51
TX4 EXPT	\$51.18
GRS MTAX	\$7.10
RFD MTAX	-1.16
M-TAX	\$5.94
GST EXPT	\$2355.92
PST TTL	\$163.30
GST TTL	\$61.51

■ Key capture report

08/26/2002	10:35PM	
123456#1730	JACK0001	
#0179	XX1*	
KEY CAPTURE		
#01		Capture job no.
08/26/2002	10:33PM	} Capture information
#1727	JACK0001	
CAPTURED1	12345	
#02		
08/26/2002	10:32PM	
#1725	JACK0001	
CAPTURED2	212121	

Individual server report

Sample X report

08/26/2002	10:45PM		
123456#1744	JACK0001		
#0141	%K1*		
IND.SERVER			
SRV#0001	JACK	Server code	
NET1	\$26519.80	Server name	
V.CP UPC 00	\$0.00	Net sales total	
GRATUITY	-15.60	Gratuity total	
CA TIP 00	\$0.00	Cash tip-in	
CH TIP 00	\$0.00	Charge tip-in	
TIP PAID 20	\$27.00	Tip paid counter and total	
TRANS CT	20770	Transaction counter	
COVER CT	21030	Cover counter	
NET3	\$26756.42		
CLOSE CK 00	\$0.00	Closed GLU/PBLU counter and total	
OPEN CK 00	\$0.00	Open GLU/PBLU counter and total	
TRAN.OUT 10	\$26.75	Transfer-out counter and total	
TRAN.IN 10	\$26.75	Transfer-in counter and total	
***RA 30	\$230.00		
***RA2 20	\$130.00		
***PD 10	\$60.00		
***PD2 10	\$30.00		
REFUND 500	\$313.16		
RETURN 20	\$7.43		
DIR VD 90	\$25.88		
PAST VD 60	\$59.30		
<->1 30	-3.45		
<->2 30	-4.36		
%1 40	-20.78		
%2 30	-11.23		
<->3 80	-12.08		
<->4 80	-13.84		
<->5 90	-12.24		
%3 120	-5.09		
%4 130	-4.44		
%5 110	-6.41		
GDISC%1 20	-78.03		
GDISC%2 20	-148.12		
GDISC%3 20	-187.65		
GDISC%TL 60	-413.80		
GAS(-)1 10	-9.84		

Sample Z report

08/26/2002	11:16PM
123456#1829	JACK0001
#0141	%Z1*
IND.SERVER	
SERVER Z1/Z2	0003

The subsequent printout occurs in the same format as in the sample X report.

GAS(-)19 10	-41.40
DRW CNT 630	
CONV 1	130.00
CONV 2	100.00
CONV 3	120.00
CONV 4	70.00
FS ID	\$134.00
CASH 20110	\$25191.41
CASH2 30	\$61.77
CASH3 20	\$50.16
CASH4 20	\$46.06
CASH5 20	\$26.33
CHARGE1 60	\$209.48
CHARGE1- 10	-13.14
CHARGE9 40	\$159.60
CHARGE9- 10	-7.88
CHECK1 40	\$83.00
CHECK2 10	\$42.00
CHECK3 20	\$130.00
CHECK4 10	\$56.00
CHECK5 10	\$100.00
CA+CH ID	\$25550.19
***CID	\$25139.19
GROUP1 17670	\$6659.71
GROUP8 00	\$0.00
GROUP9 50	\$7.50

NOTE

When the tip amount remains unchanged in Individual Server Resetting, the tip paid function is automatically executed and a tip receipt is printed on the report printer prior to report printing.

■ Full server report

- Sample X report

```
08/26/2002    10:55PM  
123456#1746   JACK0001  
  
#0140  %*1%  
ALL SERVER
```

- Sample Z report

```
08/26/2002    11:18PM  
123456#1831   JACK0001  
  
#0140  %Z1%  
ALL SERVER  
  
SERVER Z1/Z2    0004 — Reset counter
```

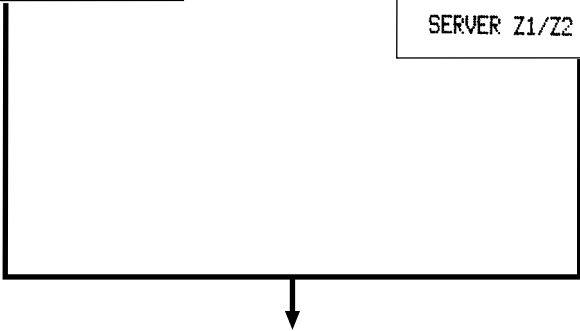

The subsequent printout occurs in the same format as in the sample report shown in the "Individual server report"; and sales data on servers print in this sequence.

■ Hourly report

• Sample X report

08/26/2002	7:50PM		
123456#1511	JACK0001		
#0160 *X<1*			
HOURLY			
10:00AM	Transaction counter		
155Q		\$1331.42	Sales total
COVER CT			
155Q	Cover counter		
AVE.		\$8.59	
10:30AM			
180Q	Average sales amount per customer (Sales total/cover counter)	\$1546.60	
COVER CT			
180Q			
AVE.		\$8.59	
SUBTOTAL			
335Q	Subtotal (10:00 - 10:59)	\$2878.02	
COVER CT			
335Q			
7:00PM			
153Q		\$1314.61	
COVER CT			
153Q			
AVE.		\$8.59	
7:30PM			
162Q		\$1391.94	
COVER CT			
162Q			
AVE.		\$8.59	
SUBTOTAL			
315Q		\$2706.55	
COVER CT			
315Q			

• Sample Z report

08/26/2002	11:21PM		
123456#1828	JACK0001		
#0160 *Z1*			
HOURLY			
HOURLY Z1		0001	

↓

The subsequent printout occurs in the same format as in the sample X report.

NOTE The hourly report can be formatted by 15 min., 30 min., or 1 hour intervals depending upon programming.

■ GLU/PBLU report

• Sample X report

08/26/2002	10:56PM	
123456#1750	JACK0001	
#0180	%<1%	
GLU		
1#	1-9999	Range
COVER CT	2Q	Table#/PBLU code
0001		Server code
COVER CT	2Q	Cover counter
***PBAL	\$36.30	Balance amount
8T	0002	"T": This table#/PBLU code was used in the training mode.
COVER CT	2Q	
***PBAL	\$72.25	
FREE GLU		Free table#/PBLU code
7#		(This number or code has been transferred out.)
COVER CT	2Q	
***PBAL	\$56.19	
***TOTAL		Total
COVER CT	9Q	
***PBAL	\$214.79	

• Sample Z report

08/26/2002	11:20PM
123456#1832	JACK0001
#0180	%Z1%
GLU	
GLU Z1	0003

↓
The subsequent printout occurs in the same format as in the sample X report.

■ GLU/PBLU report by server

• Sample X report

08/26/2002	10:57PM	
123456#1752	JACK0001	
#0181	%<1%	
GLU BY SERVER		
SRV#0001	JACK	Server code
1#		Server name
COVER CT	2Q	Table#/PBLU code
***PBAL	\$36.30	Cover counter
FREE GLU		Balance amount
7#		
COVER CT	2Q	
***PBAL	\$56.19	
***TOTAL		Total
COVER CT	9Q	
***PBAL	\$214.79	

• Sample Z report

08/26/2002	11:20PM
123456#1833	JACK0001
#0181	%Z1%
GLU BY SERVER	
GLU Z1	0004

↓
The subsequent printout occurs in the same format as in the sample X report.

■ Closed GLU/PBLU report

• Sample X report

08/26/2002	10:57PM		
123456#1759	JACK0001		
#0182	XX1*		
CLOSED GLU			
0019#	0001-9999	0001	
TEL#1			
COVER CT	20		
CHARGES		\$36.27	
TIP AMT		\$0.00	
FIN.BAL		\$36.27	
0020#		0001	
TEL#2			
COVER CT	30		
CHARGE6		\$72.20	
TIP AMT		\$0.00	
FIN.BAL		\$72.20	
FIN.BAL		\$39.42	
***TOTAL			
COVER CT	110		
CASH	10	\$55.29	} Total
CHK/CG	20	\$8.42	
CHECK1	10	\$60.00	
CHECK2	10	\$50.00	
CHARGES	10	\$36.27	
CHARGE6	20	\$122.21	
CONV 1	10	52.24	
TIP AMT	00	\$0.00	
FIN.BAL	70	\$354.77	

• Sample Z report

08/26/2002	11:22PM		
123456#1834	JACK0001		
#0182	XZ1*		
CLOSED GLU			
GLU Z1		0005	

↓

The subsequent printout occurs in the same format as in the sample X report.

■ Closed GLU/PBLU report by server

• Sample X report

08/26/2002	10:58PM		
123456#1762	JACK0001		
#0183	XX1X		
CL-GLU BY SERV			
SRV#0001	JACK	Server code	Server name
0019#		Bill no.	
TEL#1		Table#	
COVER CT	20	Cover counter	
CHARGE5		Amount	\$36.27
TIP AMT		Tip amount by tip edit	\$0.00
FIN.BAL		Final balance amount	\$36.27
0020#			
TEL#2			
COVER CT	30		
CHARGE6			\$72.20
FIN.BAL			\$39.42
***TOTAL			
COVER CT	110		
CASH	10		\$55.29
CHK/CG	20		\$8.42
CHECK1	10		\$60.00
CHECK2	10		\$50.00
CHARGE5	10		\$36.27
CHARGE6	20		\$122.21
CONV 1	10		52.24
TIP AMT	00		\$0.00
FIN.BAL	70		\$354.77

• Sample Z report

08/26/2002	11:23PM
123456#1836	JACK0001
#0183	XZ1X
CL-GLU BY SERV	
GLU Z1	0006

↓

The subsequent printout occurs in the same format as in the sample X report.

■ X1/Z1 stacked reports

You can print multiple X1/Z1 reports in sequence under a single report job number. In this case, you need to program in advance which X1/Z1 reports should be printed. Refer to "Stacked report" under the section "Report Programming" in Chapter 13.

Periodic Consolidation

Your POS terminal allows you to take consolidation X and Z reports of a chosen period (the period is usually one week or month).

- **General overview**

The periodic reading or resetting reports are the same in format as those in the X1/Z1 report for daily sales information except mode indication ("X2" or "Z2").

■ Transaction report

- **Sample X report**

```
08/26/2002    11:50PM
123456#1850    JACK0001

#0230 *X2*
TRANSACTION
```

Read symbol
Report title

- **Sample Z report**

```
08/26/2002    11:51PM
123456#1852    JACK0001

#0230 *Z2*
TRANSACTION

TRANS. Z1      0012
TRANS. Z2      0002
GT1 $00000027423.37
GT2 $00000028440.46
GT3 -00000001017.09
TR  $00000000249.14
```

Reset symbol
Report title
Reset counter of periodic consolidation
Grand totals

The subsequent printouts are the same in format as those in the X/Z report on daily totals.

■ Daily net report

• Sample X report

09/30/2002	10:35PM		
123456#5132	JACK0001		
#0270 *XZ2*			
DAILY NET			
09/01	1350	\$1159.35	
09/02	1080	\$927.48	
09/03	1440	\$1236.64	
09/29	1530	\$1313.93	
09/30	1620	\$1391.22	
***TOTAL			
	9720	\$8347.32	

Date
Transaction counter
Sales total

• Sample Z report

09/30/2002	11:00PM		
123456#5162	JACK0001		
#0270 *XZ2*			
DAILY NET			
DAILY NET Z2		0002	



The subsequent printout occurs in the same format as in the sample X report.

Customer sales report 1 and 2

NOTE Customer sales report 1 and 2 are printed in the same format except the report title. You can print either report depending on the programming of CUSTOMER DATA in FUNC.SELECT2 menu. On the customer sales report 1, you can print (and reset in Z2 mode) details (date/sales item) only. On the customer sales report 2, you can print (and reset in Z2 mode) accumulated sales q'ty/total and details.

12/16/2002	9:06PM		
123456#1860	JACK0001		
#0285 X1Z*			*
CUSTOM SALES1			
#0000000000001-			
#9999999999999		Code range	
#0000000000020		Customer code	
NAME-20		Name	
ADDRESS-20		Address	
2Q	\$36.17	Sales q'ty and total	
CHARGE	\$36.17	Charge account	
12/16/2002		Date	
F*00005			
PLO0005-1 1Q	\$3.20	Sales items	
F*00003			
PLO0003-1 1Q	\$3.32		
#0000000065321			
NAME-65321			
ADDRESS-65321			
1Q	\$9.43		
CHARGE	\$9.43		
12/16/2002			
F*00002			
PLO0002-1 1Q	\$2.80		
F*00003			
PLO0003-1 1Q	\$3.32		
F*00003			
PLO0003-1 1Q	\$3.32		
SUBTOTAL 4Q	\$89.38	Subtotal on the report	
CHARGE	\$89.38		
***TOTAL 4Q	\$89.38	The full total on the customer file	
CHARGE	\$89.38		

* When you take a Z report, "Z2" is printed instead of "X2".

Customer sales report by sales range

#0286 X2Z*		
CUSTOM BY AMT		
	\$0.01-\$9999999.99	Sales range
#0000000000020		Customer code
NAME-20		Name
ADDRESS-20		Address
	20	\$36.17
		Sales q'ty and total
CHARGE		\$36.17
		Charge account
12/16/2002		Date
F00005		
P00005-1 10		\$3.20
		Sales items

* When you take a Z report, "Z2" is printed instead of "X2".

#0000000065321		
NAME-65321		
ADDRESS-65321		
	10	\$9.43
		Charge account
CHARGE		\$9.43
		Date
12/16/2002		
F00002		
P00002-1 10		\$2.80
		Sales items

SUBTOTAL	40	\$89.38	Subtotal on the report
CHARGE		\$89.38	
***TOTAL	40	\$89.38	The full total on the customer file
CHARGE		\$89.38	

Customer charge account report

12/16/2002	9:16PM	
123456#1864	JACK0001	
#0288 X2Z*		
CHARGE ACCOUNT		
#0000000000020		Customer code
NAME-20		Name
ADDRESS-20		Address
CHARGE		\$36.17

X2/Z2 stacked report

You can print multiple X2/Z2 reports in sequence under a single transaction. In this case you need to program in advance which X2/Z2 reports should be printed. Refer to "Stacked report" under Section "Report Programming" in Chapter 13 "Programming."

ADDRESS-65321		
CHARGE		\$9.43
SUBTOTAL		
CHARGE		\$89.38
***TOTAL		
CHARGE		\$89.38

* When you take a Z report, "Z2" is printed instead of "X2".

11

Non-accessed UPC, Dynamic UPC and Customer Deletion

X1/Z1 MODE

X2/Z2 MODE

You can delete UPCs and customers that had not been accessed for a certain period. You can program a period in the PGM2 mode. As for customer, you can also delete customers with regardless to a non-accessed period.

Follow the procedure shown below.

Non-accessed UPC deletion

1. Move the mode key to X1/Z1 position.
2. Select "6 UPC DELETE".
3. Select "1 READING" to take a report, or "2 DELETE" to delete non-accessed UPCs.
4. When you select "2 DELETE", select whether you want to delete all the non-accessed UPCs (1 ALL DELETE) or delete the non-accessed UPCs individually (2 IND.DELETE).

NOTE *It is recommended to take a report first before executing deleting operation.*

Dynamic UPC clear

1. Move to the mode key to X1/Z1 position.
2. Select "6 UPC DELETE".
3. Select "3 D-UPC CLEAR" to clear by designated range, "4 D-UPC CLR PICK" to clear by pick up codes (see the "NOTE" on page 66), or "5 D-UPC CLR DEPT" to clear by associated department.

Non-accessed customer deletion

1. Move the mode key to X2/Z2 position.
2. Select "5 NO ACCESS. CUST.".
3. Select "1 READING" to take a report, or "2 DELETE" to delete non-accessed customers.
4. When you select "2 DELETE", select you want to delete all the non-accessed customers (1 ALL DELETE) or delete the non-accessed customers individually (2 IND.DELETE).

NOTE *It is recommended to take a report first before executing deleting operation.*

Customer deletion

1. Move the mode key to X2/Z2 position.
2. Select "6 CUSTOM DELETE".
3. Specify the range (start/end customer codes) you want to delete.

■ Non-accessed UPC report

	#0105	XZ1		*1
	UPC DELETE			
	UPC			
UPC code	3112345678905#			
Item label	ITEM-J-1	0Q	\$0.00	
	ITEM-J-2	0Q	\$0.00	
	ITEM-J-3	0Q	\$0.00	
	ITEM-J-4	0Q	\$0.00	
	ITEM-J-5	0Q	\$0.00	
	ITEM-J-6	0Q	\$0.00	
	322222222221#			
	ITEM-U-1	0Q	\$0.00	
	ITEM-U-2	0Q	\$0.00	
	ITEM-U-3	0Q	\$0.00	
	ITEM-U-4	0Q	\$0.00	
	ITEM-U-5	0Q	\$0.00	
	ITEM-U-6	0Q	\$0.00	
				*2

*1 When you select "DELETE", "Z1" is printed instead of "X1".

*2 When there is any sales data of the UPC for PLU/UPC report, the data is printed here.

When you delete the UPC in Z1 mode under this situation, the UPC data for PLU/UPC report is also deleted.

■ Non-accessed customer report

12/19/2002	9:37PM		
123456#1876	JACK0001		
#0287	XZ2		*
NO ACCES.CUST.			
#0000000000075			Customer code
NAME-75			Name
ADDRESS-75			Address
	0Q	\$0.00	
CHARGE		\$0.00	
#0000000000123			
NAME-123			
ADDRESS-123			
	0Q	\$0.00	
CHARGE		\$0.00	
SUBTOTAL	0Q	\$0.00	
CHARGE		\$0.00	
***TOTAL	5Q	\$95.78	
CHARGE		\$95.78	

* When you select "DELETE", "Z2" is printed instead of "X2".

■ Customer delete report

#0298 *Z2*		
CUSTOM DELETE		
#0000000000001-		
	#9999999999999	Customer range
	#0000000000020	Customer code
	NAME-20	Name
	ADDRESS-20	Address
	2Q	\$36.17
CHARGE		\$36.17
CHARGE		\$9.43
SUBTOTAL	5Q	\$95.78
CHARGE		\$95.78
***TOTAL	5Q	\$95.78
CHARGE		\$95.78

■ Dynamic UPC clear

(by designated range)

#0168 *Z1*		
D-UPC CLEAR		
1000000000000-		
9999999999999		
1123456789005#		
ITM(2)-1	6Q	\$19.02
NET SLS	6Q	\$19.02
		100.00%
ITM(2)-6	11Q	\$34.87
NET SLS	11Q	\$34.87
		100.00%

***TOTAL	6Q	\$19.02
WASTE TL	0Q	\$0.00
		0.00%
RF TL	0Q	\$0.00
CP	0Q	\$0.00
NET TL	6Q	\$19.02
		100.00%
NET TL	11Q	\$34.87
		100.00%

(by pickup list)

#0168 *Z1*		
D-UPC CLEAR		

(by associated dept.)

#0167 *Z1*		
D-UPC CLR DEPT		
DPT.01		D01

*1
If you need these information,
please consult your dealer.

12

How to Use the Programming Keyboard

Programming Keyboard Layout

When you are in the PGM 1 or PGM 2 mode, the keyboard layout will be set to the one for programming as shown below.

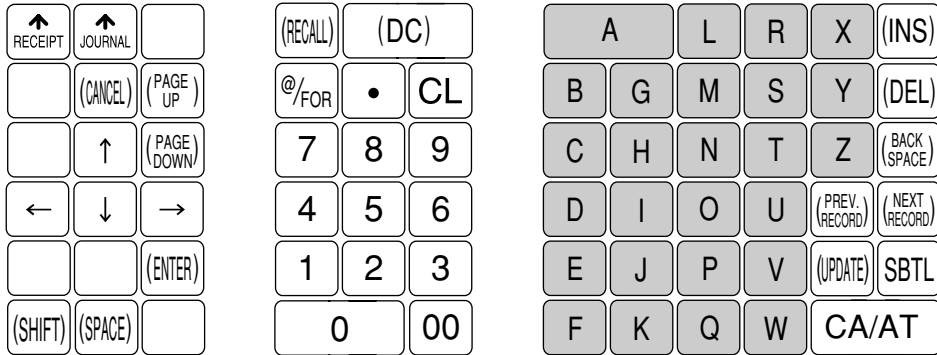

[Shaded Area] : The shaded area contains the character keys which are used for programming characters.

(SHIFT) (DC) (INS) (DEL) (BACK SPACE) : Used for programming characters. For more information about programming characters, see the section “How to Program Alphanumeric Characters.”

→ ← ↑ ↓ : Used to move the cursor.

(ENTER) : Used to program each setting.

CA/AT : Used to finalize programming.

(CANCEL) : Used to cancel programming and to get back to the previous screen.

(PREV. RECORD) : Used to go back to the previous record, e.g., from the department 2 programming window back to the department 1 programming window.

(NEXT RECORD) : Used to go to the next record, for example, in order to program unit prices for sequential departments.

(PAGE DOWN) : Used to scroll the window to go to the next page.

(PAGE UP) : Used to scroll the window to go back to the previous page.

CL : Used to clear the last setting you have programmed or clear the error state.

• : Used to toggle between two or more options.

SBTL : Used to list those options which you can toggle by the **•** key.

(RECALL) : Used to call up a desired code.

(UPDATE) : Used to update PLU unit price or name.

Numeric keys: Used for entering figures.

For more information about using these keys, see “Basic Instructions” section in Chapter 13 “Programming.”

How to Program Alphanumeric Characters

This section discusses how to program alphanumeric characters such as “DESCRIPTION,” “NAME” and “TEXT.”

■ Using character keys on the keyboard

Entering alphanumeric characters

To enter a character, simply press a corresponding character key on the programming keyboard.

To enter a digit, simply press a corresponding numeric key.

Entering double-size characters

 : This key toggles the double-size character mode and the normal-size character mode. The default is the normal-size character mode. When the double-size character mode is selected, the letter “W” appears at the bottom of the display.

Entering upper-case letters

 : You can enter an upper-case letter by using this key. Press this key just before you enter the upper-case letter. You should press this key each time you enter an upper-case letter.

Editing text

You can edit the text you have entered by deleting and/or inserting characters.

To select a text editing mode

 : Toggles between the insert mode (“_”) and the overwrite (“■”) mode.

To move the cursor

 or  : Moves the cursor.

To delete a character or figure

 : Deletes a character or figure in the cursor position.

 : Backs up the cursor for deleting the character or figure at the left of the cursor. When your POS terminal is in the insert mode, this key deletes the character or the value at the cursor position.

Text copy/paste

Copy (to the buffer): Move the cursor to the target text line to copy, and press  key.

Paste (from the buffer): Move the cursor to the target text line to paste, and press  key.

■ Entering character codes

Numerals, letters and symbols are programmable by pressing the **00** key followed by character codes. Use the following procedure with the cursor placed at the position where you want to enter characters:

00 → XXX XXX: Character code (3 digits)

Character code:

032 - 047	032	033	034	035	036	037	038	039	040	041	042	043	044	045	046	047
		!	"	#	\$	%	&	'	()	*	+	,	-	.	/
048 - 063	048	049	050	051	052	053	054	055	056	057	058	059	060	061	062	063
	0	1	2	3	4	5	6	7	8	9	:	;	<	=	>	?
064 - 079	064	065	066	067	068	069	070	071	072	073	074	075	076	077	078	079
	@	A	B	C	D	E	F	G	H	I	J	K	L	M	N	O
080 - 095	080	081	082	083	084	085	086	087	088	089	090	091	092	093	094	095
	P	Q	R	S	T	U	V	W	X	Y	Z	[\]	^	_
096 - 111	096	097	098	099	100	101	102	103	104	105	106	107	108	109	110	111
	`	a	b	c	d	e	f	g	h	i	j	k	l	m	n	o
112 - 127	112	113	114	115	116	117	118	119	120	121	122	123	124	125	126	127
	p	q	r	s	t	u	v	w	x	y	z	{		}	~	△
128 - 143	128	129	130	131	132	133	134	135	136	137	138	139	140	141	142	143
	Ç	ü	é	â	ä	à	ã	ç	ê	ë	è	ï	î	ì	ñ	Å
144 - 159	144	145	146	147	148	149	150	151	152	153	154	155	156	157	158	159
	É	æ	Œ	ô	ö	ò	û	ù	ÿ	ö	ü	ç	£	¥	℞	f
160 - 175	160	161	162	163	164	165	166	167	168	169	170	171	172	173	174	175
	á	í	ó	ú	ñ	Ñ	º	º	¿	¡	½	¼	¿	«	»	
176 - 191	176	177	178	179	180	181	182	183	184	185	186	187	188	189	190	191
	⋮	⋮	⋮													
192 - 207	192	193	194	195	196	197	198	199	200	201	202	203	204	205	206	207
	⌞	⌞	⌞	⌞	⌞	⌞	⌞	⌞	⌞	⌞	⌞	⌞	⌞	⌞	⌞	⌞
208 - 223	208	209	210	211	212	213	214	215	216	217	218	219	220	221	222	223
	⌞	⌞	⌞	⌞	⌞	⌞	⌞	⌞	⌞	⌞	⌞	⌞	⌞	⌞	⌞	⌞
224 - 239	224	225	226	227	228	229	230	231	232	233	234	235	236	237	238	239
	α	β	γ	π	Σ	σ	μ	τ	ϑ	θ	Ω	δ	ω	φ	€	Π
240 - 255	240	241	242	243	244	245	246	247	248	249	250	251	252	253	254	255
	≡	±	≥	≤	∫	∫	÷	≈	°	.	-	√	∞	z	■	(DC)

*(DC) : Double-size character code

"_" (095): Line feed code

■ : Shade characters can not be printed by the built-in printer (display only).

13

Programming

PGM1 MODE

PGM2 MODE

This chapter explains how to program various items. Before you start programming, turn the mode switch to PGM1 or PGM2 depending on the item you are going to program.

Basic Instructions

This section illustrates the basic programming by using an example of programming for departments.

Procedure

PGM2	↓
01 READING	
02 SETTING	
03 AUTO KEY	
04 D-UPC LOAD	
05 DATA CLEAR	
06 OPEN STORE	

(ENTER) ↓ ↑ (CANCEL)

SETTING	↓
01 ARTICLE	
02 DIRECT KEY	
03 PLU MENU KEY	
04 FUNCTION	
05 MEDIA	
06 TEXT	

(ENTER) ↓ ↑ (CANCEL)

ARTICLE	↓
01 DEPARTMENT	
02 PLU/UPC	
03 DYNAMIC UPC	
04 PLU RANGE	
05 PLU STOCK	
06 LINK PLU TABLE	

(ENTER) ↓ ↑ (CANCEL)

■ Programming example

The following example shows how to program \$2.00 for the unit price, "ABCDE" for the description, and the scale entry to be enabled for department 1.

1. In the PGM2 window, select "02 SETTING" by using the (↑) or (↓) key and press the (ENTER) key.
 - The SETTING window will appear.

NOTE

- You can also select "02 SETTING" by pressing the (2) and (ENTER) keys.
- If you return to the previous screen, press the (CANCEL) key.

2. Select "01 ARTICLE."

- The ARTICLE window will appear.

NOTE

The arrow mark in the upper-right corner of the window shows that the window contains more options than are now on the screen. To scroll the window, press the (PAGE DOWN) key.

To return to the previous page, press the (PAGE UP) key.

3. Select "01 DEPARTMENT."

- The DEPARTMENT window will appear, listing programmable departments.

DEPARTMENT	↓
01 DPT.01	
02 DPT.02	
03 DPT.03	
04 DPT.04	
05 DPT.05	
06 DPT.06	

(ENTER) ↓ ↑ (CANCEL)

01	↓
PRICE	200_
SIGN	+
DPT.01	
ITEM UP	NON-COMPUL.
TARE NO.	0
SCALE	INHIBIT

↓ ↑

01	↓
PRICE	2.00
SIGN	+
DPT.01	
ITEM UP	NON-COMPUL.
TARE NO.	0
SCALE	INHIBIT

↓ ↑

01	↓
PRICE	2.00
SIGN	+
ABCDE	
ITEM UP	NON-COMPUL.
TARE NO.	0
SCALE	ENABLE

-
4. Select "01" to program for department 1.
- The "01" window will appear.

-
5. On the first page of the "01" window, program the unit price and description as follows:

NOTE

There are three entry patterns for the programming: the numeric entry, character entry, and selective entry.

- Move the cursor to "PRICE," enter "200" by using numeric keys, then press the (ENTER) key. → **Numeric entry**
- Move the cursor to "DPT.01," enter "ABCDE" by using character keys, then press the (ENTER) key. → **Character entry**

If you want to clear the setting, press the (CL) key before you press the (ENTER) key.

-
6. On the first page of the "01" window, program the machine to enable the scale entry as follows:

- Move the cursor to "SCALE," press the (•) key until "ENABLE" appears, then press the (ENTER) key. → **Selective entry**

NOTE

The (•) key toggles between three options as follows: INHIBIT → ENABLE → COMPUL. → INHIBIT → Pressing the (SBTL) key displays all available options.

-
7. Select one of the following actions:

- To cancel the programming, press the (CANCEL) key. Select "YES" in the "ARE YOU SURE ?" window.
- To finalize the programming, press the (CA/AT) key, then press the (CANCEL) key. You will return to the "DEPARTMENT" window.
- To program for the following department, press the (NEXT RECORD) key. The "02" window will appear. To return to the "01" window, press the (PREV. RECORD) key.

The following sections describe how to program each item which is contained in a programming group.

Article Programming

Use the following procedure to select any option included in the article programming group.

Procedure

SETTING ↓

- 01 ARTICLE
- 02 DIRECT KEY
- 03 PLU MENU KEY
- 04 FUNCTION
- 05 MEDIA
- 06 TEXT



ARTICLE ↓

- 01 DEPARTMENT
- 02 PLU/UPC
- 03 DYNAMIC UPC
- 04 PLU RANGE
- 05 PLU STOCK
- 06 LINK PLU TABLE



ARTICLE ↑

- 07 CONDIMENT TBL.
- 08 MIX&MATCH
- 09 COMBO MEAL
- 10 SCALE TABLE
- 11 UPC NON-PLU
- 12 UPC DELETE

1. In the SETTING window, select “01 ARTICLE.”
 - The ARTICLE window will appear.

2. Select any option from the following options list:

1 DEPARTMENT:	Departments
2 PLU/UPC:	PLUs/UPCs
3 DYNAMIC UPC:	Dynamic UPC
4 PLU RANGE:	A range of PLUs
5 PLU STOCK:	PLU/UPC stock quantity
6 LINK PLU TABLE:	Link PLU table
7 CONDIMENT TBL.:	Condiment table
8 MIX&MATCH:	Mix & match table
9 COMBO MEAL:	Combo meal table
10 SCALE TABLE:	Scale table
11 UPC NON-PLU:	UPC non-PLU type code format
12 UPC DELETE:	UPC record delete period

The following illustration shows those options included in the article programming group.

1 ARTICLE	— 1 DEPARTMENT
	— 2 PLU/UPC
	— 3 DYNAMIC UPC
	— 4 PLU RANGE
	— 5 PLU STOCK
	— 6 LINK PLU TABLE
	— 7 CONDIMENT TBL.
	— 8 MIX&MATCH
	— 9 COMBO MEAL
	— 10 SCALE TABLE
	— 11 UPC NON-PLU
	— 12 UPC DELETE

- ➔ See “Department” on page 100.
- ➔ See “PLU/UPC” on page 102.
- ➔ See “Dynamic UPC” on page 105.
- ➔ See “PLU range” on page 105.
- ➔ See “PLU/UPC stock” on page 106.
- ➔ See “Link PLU table” on page 107.
- ➔ See “Condiment table” on page 108.
- ➔ See “Mix & Match table” on page 109.
- ➔ See “Combo meal table” on page 110.
- ➔ See “Scale table” on page 111.
- ➔ See “UPC Non-PLU code format” on page 112.
- ➔ See “UPC delete” on page 113.

■ Department

Your machine is equipped with 20 standard departments, and can be equipped with a maximum of 99 departments.

Use the following procedure to program for departments.

Procedure

Select the desired dept. code from the departments list.

↓

01	↓
PRICE	0.00
SIGN	+
DPT. 01	
ITEM VP NON-COMPUL.	
TARE NO.	0
SCALE	INHIBIT

↓

01	↑↓
SIF/SICS	NORMAL
DEPT. TYPE	NORMAL
ENTRY TYPE	OPEN
TAXABLE 1	NO
TAXABLE 2	NO
TAXABLE 3	NO

The screen continues.

Program each item as follows:

NOTE

For more information about the entry patterns, see the "Basic Instructions" section.

- **PRICE (Use the numeric entry)**

Unit price (max. 6 digits)

NOTE

When the zero-value department entry (unit price "0") is made, a text of the department is only displayed/printed.

- **SIGN (Use the selective entry)**

+: Assigns a plus sign to departments for normal sales transactions.

-: Assigns a minus sign for minus transactions.

- **DPT.01<Default for dept.1> (Use the character entry)**

Description for a department. Up to 8 or 16 characters can be entered.

- **ITEM VP (Use the selective entry)**

COMPUL.: Makes item validation printing compulsory.

NON-COMPUL.: Makes item validation printing non-compulsory.

- **TARE NO. (Use the numeric entry)**

Tare table number associated with scale entry (1 thru 9).

- **SCALE (Use the selective entry)**

INHIBIT: Inhibits a scale entry.

COMPULSORY: Makes a scale entry compulsory.

ENABLE: Enables a scale entry.

- **SIF/SICS (Use the selective entry)**

Department type selection

SIF: SIF department

SICS: SICS department

NORMAL: Department other than SIF or SICS department

- **DEPT. TYPE (Use the selective entry)**

Department type selection

GAS: Gas department

BR: Bottle return department

HASH: Hash department

NORMAL: Normal department

- A hash department is used to enter the amount of a special "sale," such as a gift certificate, etc. Any amounts entered in this department are not added to the grand total exclusive of tax amounts.

- **ENTRY TYPE (Use the selective entry)**

Type of unit price entry for departments

OPEN & PRES.: Open & preset

PRESET: Preset only

OPEN: Open only

INHIBIT: Inhibited

■ Department (continued)

- **TAXABLE 1 thru 4 (Use the selective entry)**

Tax status

NO : Non-taxable

YES : Taxable

- When an entry of a taxable department is made in a transaction, tax is automatically computed according to the associated tax table or rate.

- **FOOD STAMP (Use the selective entry)**

Food stamp status

NO : Food stamp ineligible

YES : Food stamp eligible

- **GR. DISC. 1 thru 3 (Use the selective entry)**

Group discount status

NO : Non-discountable

YES : Discountable

- **HALO (Use the numeric entry)**

- You can set an upper limit amount (HALO) for each department. The limit is effective for the REG-mode operations and can be overridden in the MGR mode.

- AB is the same as $A \times 10^B$

A: Significant digit for HALO (1 thru 9)

B: Number of zeros to follow the significant digit for HALO (0 thru 7)

- **LALO (Use the numeric entry)**

- You can set a lower limit amount (LALO). The limit is effective for the REG-mode operations and can be overridden in the MGR mode.

- AB is the same as $A \times 10^B$

A: Significant digit for LALO (1 thru 9)

B: Number of zeros to follow the significant digit for LALO (0 thru 7)

- **AGE LIMIT. (Use the numeric entry)**

Age limitation (0 thru 99)

When a department for which a figure other than zero (01 to 99) has been programmed as the age limitation is entered, the birthday entry must be completed.

- **SERVER Gr. No. (Use the numeric entry)**

Server group number (0 thru 9)

Every department can be assigned to any of the server department groups. The sales total of each department group is printed on the server report.

- **GROUP No. (Use the numeric entry)**

Group number (0 thru 9)

You can assign departments to a maximum of nine groups. This programming enables you to take group sales reports.

- **MODIFIED OUTPUT (Use the selective entry)**

NO : Disables output to network remote printers.

YES : Enables output to network remote printers. Modified to follow a previous item.

- **OUTPUT KP No. 1 thru 3 (Use the numeric entry)**

ID number of the network remote printer 1, 2 or 3 (1 thru 9)

If the number "0" is entered, no remote printer will operate.

- **CHIT RECEIPT (Use the selective entry)**

YES : Prints the department sales information on the chit receipt in the remote printer format.

NO : Prints nothing on the chit receipt.

- **CVM CTRL CHAR. (Use the numeric entry)**

CVM (Color Video Monitor) control character (0 thru 255)

- This programming enables you to assign each department with a number that can be used as a CVM control character. This number is converted to a two-digit character code that is transmitted for use with a CVM device.

- **DATA ENT. JOB# (Use the numeric entry)**

Key data entry job number (Capture job number: 0 thru 99)

When "0" is programmed, data entry is inhibited.

■ PLU/UPC

NOTE

- In this manual, the word “UPC” represents UPC (Universal Product Code) and the word “EAN” represents EAN (European Article Number).
- With regard to the UPC codes available to this POS terminal, please refer to the chapter 14.

Procedure

Select the desired PLU code from the PLUs list, or directly enter a PLU/UPC code.

```

00001 ↓
PRICE 1 0.00
1# PL00001
KP1 PL00001
DEPT.CODE 01
SIGN +
ENTRY TYPE PRESET
    
```

```

00001 ↑↓
BASE Q'TY 0
MIN. STOCK 0
PRICE SHIFT ENABLE
ZERO OF P1 ALLOWED
CP OBJECT 00000
MENU TYPE NORMAL
    
```

```

00001 ↑↓
LINK TBL# 00
MIX&MATCH TBL# 00
CONDIMENT TBL# 00
TARE TBL# 0
CONDIMENT TYPE NO
CONDIMEN NON-COMPUL.
    
```

Program each item as follows:

- ***PRICE 1 thru 6 (Use the numeric entry)**
Unit price of each price level (max. 6 digits).
- ***1# thru 6 (Use the character entry)**
Description for a PLU/UPC (for each price level). Up to 8 or 16 characters can be entered.
- ***KP 1 thru 6 (Use the character entry)**
Description of text for kitchen printer for each price level. Up to 12 characters can be entered.
- **DEPT.CODE (Use the numeric entry)**
Department code to be associated with the entered PLU/UPC (01 through 99)
When a PLU/UPC is associated with a department, the following functions of the PLU/UPC depend on the programming for the department.
 - Item validation print compulsory/non-compulsory
 - Single item cash sale/single item finalize
- **SIGN (Use the selective entry)**
+: Plus PLU/UPC
-: Minus PLU/UPC
The function of every PLU/UPC varies according to the combination of its sign and the sign of its associated department as follows:

Department:	+	} Serves as a normal plus PLU/UPC
PLU/UPC:	+	
Department:	-	} Serves as a normal minus PLU/UPC
PLU/UPC:	-	
Department:	+	} Accepts store coupon entries, but not split-pricing entries.
PLU/UPC:	-	
Department:	-	} Not valid; not accepted
PLU/UPC:	+	

NOTE

- * On the sample screen, the price level 1 setting only is shown. Depending on the default settings, you may see the price level 1 through 6 settings on the screen. Please consult your authorized SHARP dealer for more details.

■ PLU/UPC (continued)

00001	↑↓
SCALE	INHIBIT
TAXABLE 1	NO
TAXABLE 2	NO
TAXABLE 3	NO
TAXABLE 4	NO
FOOD STAMP	NO

00001	↑↓
GR.DISC.1	NO
GR.DISC.2	NO
GR.DISC.3	NO
AGE LIMIT.	00
GROUP1	00
GROUP2	00

00001	↑↓
GROUP3	00
PRIORITY GR.	0
MODIFY OUTPUT	NO
OUTPUT KP No.1	0
OUTPUT KP No.2	0
OUTPUT KP No.3	0

00001	↑
OUTPUT KP No.3	0
CHIT RECEIPT	NO
CUM CTRL CHAR.	000
REPEAT ROUND	NO
DATA ENT.JOB#	00
NON-ACCESS NON DEL.	

- **ENTRY TYPE (Use the selective entry)**

Mode parameter

OPEN & PRESET: Open price and preset price

PRESET: Preset price only

OPEN: Open price only

INHIBIT: Inhibited

NOTE For UPC, it is fixed to "PRESET".

- **BASE Q'TY (Use the numeric entry)**

Base quantity for each PLU/UPC which is counted each time the item is entered. (max. 2 digits)

- **MIN. STOCK (Use the numeric entry)**

Minimum stock quantity for a PLU (max. 7 digits)

- **PRICE SHIFT (Use the selective entry)**

COMPUL.: Makes PLU/UPC price level shift compulsory.

INHIBIT: Inhibits PLU/UPC price level shift.

ENABLE: Enables PLU/UPC price level shift.

NOTE

When "COMPULSORY" is selected for a PLU/UPC, repeat entries of the PLU/UPC are inhibited.

- ***ZERO OF P1 thru 6 (Use the selective entry)**

ALLOWED: Allows a zero-price entry.

INHIBIT: Inhibits a zero-price entry.

- **CP OBJECT (Use the numeric entry)**

Select an object PLU code (max. 5 digits).

A coupon-like PLU is able to link to another PLU (object PLU).

By this programming, the associated coupon PLU cannot be entered unless the object PLU has been rung up.

(However, the quantity is not affected.)

NOTE

• Any object PLU should not be programmed as a minus PLU or belong to any minus department.

- **MENU TYPE (Use the selective entry)**

PLU menu type selection

LINK: Link PLU/UPC

NORMAL: Normal PLU/UPC

- **LINK TBL# (Use the numeric entry)**

Table number for link PLUs (1 thru 99)

- **MIX&MATCH TBL# (Use the numeric entry)**

Table number for mix and match (1 thru 99)

- **CONDIMENT TBL# (Use the numeric entry)**

Table number for condiment entry (1 thru 99)

NOTE For UPC, it is fixed to "00".

■ PLU/UPC (continued)

- **TARE TBL# (Use the numeric entry)**

Tare table number associated with scale entry (1 thru 9)

- **CONDIMENT TYPE (Use the selective entry)**

YES : Condiment type

NO : Non-condiment type

NOTE For UPC, it is fixed to "NO".

- **CONDIMENT (Use the selective entry)**

COMPUL.: Makes a condiment entry compulsory.

NON-COMPUL.: Makes a condiment entry non-compulsory.

NOTE For UPC, it is fixed to "NON-COMPUL.".

- **SCALE (Use the selective entry)**

COMPUL.: Makes a scale entry compulsory.

ENABLE: Enables a scale entry.

INHIBIT: Inhibits a scale entry.

- **TAXABLE 1 thru 4 (Use the selective entry)**

YES : Makes the PLU/UPC taxable.

NO : Makes the PLU/UPC non-taxable.

- **FOOD STAMP (Use the selective entry)**

Food stamp status

NO : Food stamp ineligible

YES : Food stamp eligible

- **GR. DISC. 1 thru 3 (Use the selective entry)**

Group discount status

NO : Non-discountable

YES : Discountable

- **AGE LIMIT. (Use the numeric entry)**

Age limitation (0 thru 99)

When a PLU/UPC for which a figure other than zero (01 to 99) has been programmed as the age limitation, the birthday entry must be completed.

- **GROUP 1 thru 3 (Use the numeric entry)**

PLU group number (00 thru 99)

- **PRIORITY GR. (Use the numeric entry)**

PLU group which is to be given the highest priority to in printing on the remote printer (1 thru 9)

- **MODIFY OUTPUT (Use the selective entry)**

NO : Will not follow previous PLUs which has the remote printer assignment.

YES : Will follow previous PLUs which has the remote printer assignment.

- **OUTPUT KP No.1 thru 3 (Use the numeric entry)**

ID number of the network remote printer 1, 2 or 3 (1 thru 9)

If the number "0" is entered, no remote printer will operate.

- **CHIT RECEIPT (Use the selective entry)**

YES : Prints the PLU sales information on the chit receipt in the remote printer format.

NO : Prints nothing on the chit receipt.

- **CVM CTRL CHAR. (Use the numeric entry)**

CVM (Color Video Monitor) control character (0 thru 255)

■ PLU/UPC (continued)

- **REPEAT ROUND (Use the selective entry)**
 YES : Allows repeat round registration
 NO : Inhibits repeat round registration
- **DATA ENT. JOB# (Use the numeric entry)**
 Key data entry job number (Capture job number: 0 thru 99)
 When "0" is programmed, data entry is inhibited.
- **NON-ACCESS (Use the selective entry)**
 NON DEL.: Not delete non-accessed UPCs by Z1 report.
 DEL. BY Z: Delete non-accessed UPCs by Z1 report.

NOTE For PLU, it is fixed to "NON DEL."

■ Dynamic UPC

NOTE For the UPC codes available to this POS terminal and type UPC files, please refer to the chapter 14.

After you select "3 DYNAMIC UPC" on the "ARTICLE" menu, enter an UPC code or select a pertinent code. The same setting items excepting MIN. STOCK as the "PLU/UPC" described in the previous section will appear. Please refer to "PLU/UPC" section for entering values or selecting options. The data will be saved in the Dynamic UPC file.

■ PLU range

You can program the PLUs by a range as follows:

Procedure

PLU RANGE	
START	00000
END	00000
OPERATION	MAINT.



00001-00020 ↓	
PRICE 1	0.00
1#	
KP1	
DEPT.CODE	
SIGN	
ENTRY TYPE	

Enter a value or select an option for each item as follows:

- **START (Use the numeric entry)**
 Starting PLU code (max. 5 digits)
- **END (Use the numeric entry)**
 Ending PLU code (max. 5 digits)
- **OPERATION (Use the selective entry)**
 MAINT.: Enables you to change the setting you have programmed.
 NEW&MAINT.: Enables you to change the current setting when the specified codes have already been created or to create new codes when the specified codes have not been created yet.
 DELETE: Enables you to delete a specified range of PLUs.

The screen continues in the same format as screens shown in section "■ PLU/UPC."

■ PLU/UPC stock

You can assign a stock quantity to each PLU/UPC code.
Shown below is an example of selecting "1 OVER WRITE."

Procedure

PLU STOCK
1 OVER WRITE
2 ADD
3 SUB



Select the desired PLU code from the PLUs list, or directly enter a PLU/UPC code.



00001	
CURRENT	0
NEW STOCK	0

After selecting "1 OVER WRITE," select a pertinent PLU/UPC code. Then the next screen will appear to show the following items:

- **CURRENT**

The current stock is displayed.

- **NEW STOCK (Use the numeric entry)**

Enter a new stock quantity (max. 7 digits: 1 to 9999.999)

NOTE

- *If you need to add or subtract a stock quantity to or from the current stock quantity, select "2 ADD" or "3 SUB" and enter a value to be added or subtracted.*
- *You cannot enter any values for the item marked with "!"*
- *The entry of a new stock value will update to the PLU/UPC stock counter.*

■ Link PLU table (for PLU/UPC)

It is possible to link PLUs (linked PLUs) with a PLU or UPC (link PLU/UPC) so that with a single key depression of the link PLU/UPC key. However, the number of links is a maximum of five. Even if more than five PLUs are linked, the sixth or higher link is not actualized.

Procedure

LINK PLU TABLE
---NOTHING---

Selected link
PLU table no. →

01	
LINKED PLU#1	00000
LINKED PLU#2	00000
LINKED PLU#3	00000
LINKED PLU#4	00000
LINKED PLU#5	00000

Program each item as follows:

- **LINK PLU TABLE (Use the numeric entry)**
Link PLU table number (1 thru 99)
- **LINKED PLU#1 thru 5 (5 PLUs. max.)**
Select linked PLUs (max. 5 PLUs) from the list.

NOTE

- *PLU codes should be defined before programming a link PLU table.*
- *If the key is pressed on the table number selection menu, the selected table will be deleted.*

■ Condiment table

The “condiment entry” is intended to guide the operator in making menu entries which require special cooking instructions. For example, a server can make such entries as “garnishing potato,” “with salad,” and “grilling steak rate.” When a server enters a menu-item PLU to which PLUs for the condiment entry have been assigned, these orders (such as “garnishing potato”) will be printed on the receipt and conveyed to the kitchen.

Before you program for the condiment entry, prepare a condiment table. The following shows an example of a condiment table:

Condiment table

Table number	PLU codes for condiment entry (programmed text)					
01	Message text (HOWCOOK?)	23 (RARE)	25 (MED.RARE)	27 (WELLDONE)	02
02	Message text (WITH?)	44 (SALAD)	45 (FRUITS)		
⋮	⋮	⋮	⋮	⋮	⋮	⋮
04	Message text (POTATO?)	33 (P.CHIPS)	37 (MASHED.P)	38 (BAKED.P)	99
99	Message text (DRINK?)	63 (TEA)	65 (MILK)	67 (A.JUICE)	/

PLUs (Up to 15 for a table)
Next condiment table number

Condiment tables (Up to 99)

The condiment table should contain the following:

Condiment table: The condiment table is a group of condiment PLUs, which is assigned to each menu-item PLU. A table consists of a message text and up to 15 PLUs. Also, you can assign the next condiment table number to a condiment table to link them.

The message text is used for displaying a prompting message. The PLU is used for the special order setting. For example, when a server enters a menu-item PLU, a display message programmed for the message text such as “HOWCOOK?.” will appear. Then specify one of the PLU programmed for text such as “RARE.”

Table number: The table number is intended to identify each condiment table.

Procedure

CONDIMENT TBL.
---NOTHING---



Program each item as follows:

- **CONDIMENT TBL. (Use the numeric entry)**
Condiment table number (1 thru 99)
- **REPEAT TIMES (Use the numeric entry)**
Repeat times (1 thru 9)
When the REPEAT TIMES is programmed as 2 thru 9, its table shows repeatedly until accomplishment of the programmed number of times, then next table will be shows.
- **NEXT TABLE# (Use the numeric entry)**
Enter the next condiment table number (max. 2 digits).

Selected
condiment table
number → [ENTER]

01	
REPEAT TIMES	1
NEXT TABLE#	00
PLU#01	00000
PLU#02	00000
PLU#03	00000
PLU#04	00000

The screen continues.

■ Mix & Match table

Procedure

MIX&MATCH
---NOTHING---

Selected
mix & match
table number → [ENTER]

01	
BASE QTY	0
PRICE	0.00

• PLU#1-15 (Use the numeric key)

Select condiment PLUs contained in the table (max. 15 PLUs) from the list.

NOTE

- The description of the first PLU is used as the display prompt.
- PLU codes should be defined before programming a condiment table.
- If the [DEL] key is pressed on the table number selection menu, the table in the cursor position will be deleted.

Program each item as follows:

• MIX&MATCH (Use the numeric entry)

Mix & match table number (1 thru 99)

• BASE QTY (Use the numeric entry)

Base quantity for each mix & match table (max. 2 digits)

• PRICE (Use the numeric entry)

Unit price for each mix & match table (max. 7 digits)

NOTE

- If the [DEL] key is pressed on the table number selection menu, the table in the cursor position will be deleted.

■ Combo meal table

When two or more menu items, consisting of PLUs related to a special offering, are to be programmed together, the combo meal function should be specified. Up to 20 combo keys (tables) can be programmed. And each combo key can be associated with 9 PLUs (items).

Procedure

COMBO MEAL
---NOTHING---

Selected combo table no. →

01	↓
KP	
CONDIMENT TBL#	00
CONDIMEN NON-COMPUL.	
PRIORITY GR.	0
MODIFY OUTPUT	NO
	a

01	↑↓
OUTPUT KP No.1	0
OUTPUT KP No.2	0
OUTPUT KP No.3	0
CHIT RECEIPT	NO
CVM CTRL CHAR.	000
DATA ENT. JOB#	00

Program each item as follows

- **COMBO MEAL (Use the numeric entry)**
Combo meal table number (1 thru 20)
- **Combo title (Use the character entry)**
Title of each combo meal table (max. 16 characters).
- **KP (Use the character entry)**
Description of the kitchen printer for a combo key.
Up to 12 characters can be entered.
- **CONDIMENT TBL# (Use the numeric entry)**
Table number for condiment entry (1 thru 99)
- **CONDIMENT (Use the selective entry)**
COMPUL.: Makes a condiment entry compulsory.
NON-COMPUL.: Makes a condiment entry non-compulsory.
- **PRIORITY GR. (Use the numeric entry)**
Combo group which is to be given the highest priority to in printing on the remote printer (1 thru 9).
- **MODIFY OUTPUT (Use the selective entry)**
NO : Will not follow previous PLUs which has the remote printer assignment.
YES : Will follow previous PLUs which has the remote printer assignment.
- **OUTPUT KP No.1 thru 3 (Use the numeric entry)**
ID number of the network remote printer 1, 2 or 3 (1 thru 9).
If the number "0" is entered, no remote printer will operate.
- **CHIT RECEIPT (Use the selective entry)**
YES : Print the combo sales information on the chit receipt in the remote printer format.
NO : Print nothing on the chit receipt.
- **CVM CTRL CHAR. (Use the numeric entry)**
CVM (Color Video Monitor) control character (0 thru 255)
- **DATA ENT. JOB# (Use the numeric entry)**
Key data entry job number (Capture job number: 0 thru 99)
When "0" is programmed, the data capture entry is inhibited.

■ Combo meal table (continued)



↓

01	↑↓
COMBO PLU#1	00000
PRICE1	0.00
PRICE2	0.00
COMBO PLU#2	00000
PRICE1	0.00
PRICE2	0.00

The screen continues.

- **COMBO PLU#1-9 (Use the numeric entry)**
Select associated PLUs (max. 9 PLUs) from the list.
- **PRICE1 (Use the numeric entry)**
Unit price of each associated PLU (max. 6 digits).
- **PRICE2 (Use the numeric entry)**
2nd unit price (for Upcharge function) of each associated PLU (max. 6 digits).

NOTE

- *The PRICE1 is selected by the combo meal entry. When the  key is pressed after the combo meal entry, the entry of PRICE1 is voided and a new entry of PRICE2 is registered.*
- *PLU codes should be defined before programming a combo meal table.*
- *If the  key is pressed on the table number selection menu, the programmed data in the cursor position will be deleted.*

■ Scale table

The POS terminal can be programmed with up to nine tare tables and allows different tares to be assigned to scalable items (for auto scale entries).

Procedure

SCALE TABLE	↓
1	
2	
3	
4	
5	
6	

↓

Selected
tare table
number



↓

1	
WEIGHT	0.001b

Program each item as follows:

- **SCALE TABLE (Use the numeric entry)**
Tare table number (1 thru 9)
- **WEIGHT (Use the numeric entry)**
Enter a tare weight for the scale table number (max. 4 digits: 1 to 99.99 lbs.).

NOTE

Your POS terminal may also be set to accommodate 1-integer + 3-decimal weights. For more details, please consult your authorized SHARP dealer.

■ UPC Non-PLU code format

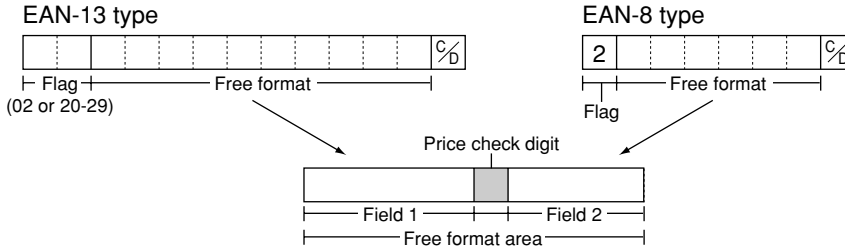

Procedure

Select an arbitrary number, or the desired UPC TYPE OF CODE & SYSTEM CODE you set.

03	↓
TYPE OF CODE	EAN13
SYSTEM CODE	00
LENGTH FLD#1	0
LENGTH FLD#2	0
FIELD#2 DATA	PRICE
PRICE C/D	NO

The screen continues.

Program each item as follows:

- **TYPE OF CODE (Use the selective entry)**

EAN-8: EAN-8 format code (consists of 8 digits)
 EAN-13 (UPC-A): EAN-13 format code (consists of 13 digits)

- **SYSTEM CODE (Use the numeric entry)**

System code (i.e. flag code): EAN-8: 1 digit, EAN-13: 2 digits

NOTE

ISBN/ISSN and press codes are always used the fixed format even if code, 37, 43, 78, 98, or 97 is entered.

- **LENGTH FLD#1 (Use the numeric entry)**

Length of field 1 (number of digits): 0 to 9

- **LENGTH FLD#2 (Use the numeric entry)**

Length of field 2 (number of digits): 0 to 9

- **FIELD#2 DATA (Use the selective entry)**

Meaning of field 2
 QUANTITY: Quantity
 PRICE: Price

- **PRICE C/D (Use the selective entry)**

Price check digit
 YES: Use the price check digit
 NO: Not use the price check digit

- **TAB (Use the selective entry)**

TAB or decimal point of field: 3/2/1/0

■ UPC delete

You can delete the UPC codes which have not been accessed during the period you set in this program when you execute the delete job while in UPC DELETE in the X1 mode.

Procedure

Program each item as follows:

- **PERIOD (DAY) (Use the numeric entry)**
Enter the UPC record delete period: 01 to 99 (00: Not delete by the non-accessed deleting job)

UPC DELETE
PERIOD(DAY) 99

Direct Key Programming

Use the following procedure to select direct-key programming:

■ Direct PLU/COMBO/Dept. key

You can assign PLUs, combo meals and departments directly to the keyboard. In the case of combo meals or PLUs, you may assign up to 10-levels to be accessed directly on the keyboard.

Procedure

SETTING
01 ARTICLE
02 DIRECT KEY
03 PLU MENU KEY
04 FUNCTION
05 MEDIA
06 TEXT

Select the desired key no. from the key numbers list (Refer to the next page).

001
TYPE PLU

001
LEVEL1 00001
LEVEL2 00000
LEVEL3 00000
LEVEL4 00000
LEVEL5 00000

In the case of setting "00001 DIRECT PLU"

1. In the SETTING window, select "02 DIRECT KEY."
 - The DIRECT KEY window will appear.

• TYPE (Use the selective entry)

- PLU: Assigns the key as a direct PLU key.
- COMBO: Assigns the key as a direct combo key.
- DEPT: Assigns the key as a direct department key.

NOTE

- You can also select a direct PLU key by pressing the corresponding key when the PLU has been assigned directly on the keyboard instead of selecting the key from the menu.
- When selecting a department, the screen on which a department code is to be entered (the message "DEPT. CODE") will appear.
- When selecting a combo, the screen on which a combo table number is to be entered ("COMBO TBL#") will appear.

• LEVEL1 thru 5 (Use the numeric entry)

- Enter a PLU number or combo table number for each level. For example, if you want to use this key as PLU code 1 (level 1) and PLU code 101 (level 2), enter 1 for the "LEVEL1" and 101 for the "LEVEL2."

Key numbers

51	57	63	69	
50	56	62	68	
49	55	61	67	
48	54	60	66	
47	53	59	65	

Departments and PLUs programmable area

NOTE

*You cannot place a department, PLU or combo meal key where a function key has been previously programmed.
For more information, please consult your authorized SHARP dealer.*

PLU Menu Key Programming

Use the following procedure to select the PLU menu key programming:

■ PLU menu key

When you enter PLUs, using the PLU menu key makes it easy to find categorized PLU items from the menu list.

Your POS terminal allows you to program a max. of 50 PLU menu keys. You can program a max. of 15 PLUs/sub-menus for each PLU menu key.

Procedure

SETTING	↓
01 ARTICLE	
02 DIRECT KEY	
03 PLU MENU KEY	
04 FUNCTION	
05 MEDIA	

PLU MENU KEY
---NOTHING---

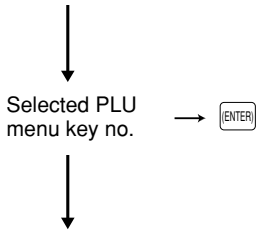

01	
TEX	

01	
TYPE	PLU

01	
PLU	00000

Use the following procedure to program a PLU menu key:

In the SETTING window, select "03 PLU MENU KEY" and program each item as follows:

- **PLU MENU KEY (Use the numeric entry)**
 PLU menu key number (1 thru 50)
 1 thru 50 : For the direct PLU menu key.
- **TEXT (Use the character entry)**
 Description for the PLU menu key. Up to 16 characters can be entered.
- **TYPE (Use the selective entry)**
 PLU: Selects to program a PLU.
 MENU: Selects to program a sub-menu.
- **PLU or MENU (Use the numeric entry)**
 Select a menu PLU or sub-menu from the list.

NOTE

When selecting a sub-menu, the screen on which a sub-menu number is to be entered (the message "MENU") will appear.

NOTE

- *The PLU code should be defined before programming a PLU menu key.*
- *If the key is pressed on the menu key number selection menu, the menu list will be canceled.*
- *If the key is pressed on the menu PLU code selection menu, the menu in the cursor position will be deleted.*

Functional Programming

Use the following procedure to select any option included in the functional programming group:

Procedure

```

SETTING ↓
01 ARTICLE
02 DIRECT KEY
03 PLU MENU KEY
04 FUNCTION
05 MEDIA
06 TEXT
    
```



```

FUNCTION ↓
01 (-)
02 %
03 GROUP DISC.%
04 GAS DISCOUNT
05 GRATUITY
06 TIP
    
```

The screen continues.

1. In the SETTING window, select "04 FUNCTION."
 - The FUNCTION window will appear.

2. Select any option from the following options list:

1 (-):	Discount key
2 %:	Percent key
3 GROUP DISC.%:	Group discount
4 GAS DISCOUNT:	Gas discount
5 GRATUITY:	Gratuity
6 TIP:	Tip
7 RA:	Received on account
8 PO:	Paid out
9 MANUAL TAX:	Manual tax
10 TAX DELETE:	Tax delete
11 NO SALE:	No-sale
12 VOID:	Void
13 REFUND:	Refund

The following illustration shows those options included in the functional programming group.

4 FUNCTION	1 (-)	➔ See "Discount key" on page 118 .
	2 %	➔ See "Percent key" on page 119 .
	3 GROUP DISC.%	➔ See "Group discount" on page 120 .
	4 GAS DISCOUNT	➔ See "Gas discount" on page 121 .
	5 GRATUITY	➔ See "Gratuity" on page 122 .
	6 TIP	➔ See "Tip" on page 122 .
	7 RA	➔ See "RA" on page 123 .
	8 PO	➔ See "PO" on page 124 .
	9 MANUAL TAX	➔ See "Manual tax" on page 124 .
	10 TAX DELETE	➔ See "Tax delete" on page 125 .
	11 NO SALE	➔ See "No sale" on page 125 .
	12 VOID	➔ See "Void" on page 126 .
	13 REFUND	➔ See "Refund" on page 126 .

■ Discount key (⊖1 thru ⊖5)

Procedure

Select the desired discount key from the discount keys list.

(-) 1	↓
AMOUNT	-0.00
TEXT	(-) 1
SIGN	-
TAXABLE1	NO
TAXABLE2	NO
TAXABLE3	NO

(-) 1	↑↓
TAXABLE4	NO
FOOD STAMP	NO
GR.DISC.1	NO
GR.DISC.2	NO
GR.DISC.3	NO
HALO	17

The screen continues.

Program each item as follows:

- **AMOUNT (Use the numeric entry)**
Discount amount (max. 6 digits: 0 to 999999)
- **TEXT (Use the character entry)**
Description for the discount key. Up to 8 characters can be entered.
- **SIGN (Use the selective entry)**
Programming of the + or – sign assigns the premium or discount function to each discount key.
–: Minus amount (discount)
+: Plus amount (premium)
- **TAXABLE1 thru 4 (Use the selective entry)**
YES: Taxable
NO: Non-taxable
- **FOOD STAMP (Use the selective entry)**
Food stamp status
NO: Food stamp ineligible
YES: Food stamp eligible
- **GR. DISC. 1 thru 3 (Use the selective entry)**
Group discount status
NO: Non-discountable
YES: Discountable
- **HALO (High Amount Lockout: use the numeric entry)**
A: Significant digit for HALO (1 thru 9)
B: Number of zeros to follow the significant digit for HALO (0 thru 7)
AB is the same as $A \times 10^B$.
- **ENTRY TYPE (Use the selective entry)**
ITEM: Item (–)
SBTL: Subtotal (–)
- **ENTRY IN REG (Use the selective entry)**
YES: Allows a discount entry in the REG mode.
NO: Inhibits a discount entry in the REG mode.

- **DATA ENT. JOB# (Use the numeric entry)**
Key data entry job number (Capture job number: 0 thru 99)
When “0” is programmed, data capture is inhibited.

- **PLU1 thru 20 (Use the numeric entry)**
Program the PLU code which is allowed for the corresponding (–) key. (1 thru 99999)

NOTE

For the Markdown coupon entry (item (–)):
The coupon entry will be allowed only for a PLU which is listed in this table.
For the Discount coupon entry (ST (–)):
The coupon entry will be allowed only when all PLUs which is listed in this table have been entered.

NOTE

You can also select a discount key by pressing the corresponding key when it has been placed directly on the keyboard instead of selecting the key from the menu.

■ Percent key ([%1 thru %5])

Procedure

Select the desired percent key from the percent keys list.

1		
RATE		-0.00%
TEXT	1	
SIGN		-
TAXABLE1		NO
TAXABLE2		NO
TAXABLE3		NO

1		
TAXABLE4		NO
FOOD STAMP		NO
GR.DISC.1		NO
GR.DISC.2		NO
GR.DISC.3		NO
%HALO		100.00%

The screen continues.

Program each item as follows:

- **RATE (Use the numeric entry)**
Percent rate (0.00 to 100.00)
- **TEXT (Use the character entry)**
Description for the percent key. Up to 8 characters can be entered.
- **SIGN (Use the selective entry)**
Programming of the + or – sign assigns the premium or discount function to each percent key.
–: Minus (discount)
+: Plus (premium)
- **TAXABLE1 thru 4 (Use the selective entry)**
YES: Taxable
NO: Non-taxable
- **FOOD STAMP (Use the selective entry)**
Food stamp status
NO: Food stamp ineligible
YES: Food stamp eligible
- **GR. DISC. 1 thru 3 (Use the selective entry)**
Group discount status
NO: Non-discountable
YES: Discountable
- **%HALO (High Amount Lockout: use the numeric entry)**
HALO (High Amount Lockout) for the percent key (0.00 to 100.00)
- **ENTRY TYPE (Use the selective entry)**
ITEM: Item %
SBTL: Subtotal %
- **DATA ENT. JOB# (Use the numeric entry)**
Key data entry job number (Capture job number: 0 thru 99)
When “0” is programmed, data entry is inhibited.
- **PLU1 thru 20 (Use the numeric entry)**
Program PLU code which is allowed for the corresponding % key. (1 thru 99999)

NOTE

For the Markdown % entry (item %):

The % entry will be allowed only for a PLU which is listed in this table.

For the Discount % entry (ST %):

The % entry will be allowed only when all PLUs which is listed in this table have been entered.

NOTE

You can also select a percent key by pressing the corresponding key when it has been placed directly on the keyboard instead of selecting the key from the menu.

■ Group discount key (GDSC %1 thru GDSC %3)

Procedure

Select the desired key from the group discount keys list.

GDISC%1	↓
RATE	-0.00%
TEXT(%)	GDISC%1
TEXT(ST)	GD1 ST
SIGN	-
TAXABLE1	NO
TAXABLE2	NO

GDISC%1	↑
TAXABLE2	NO
TAXABLE3	NO
TAXABLE4	NO
FOOD STAMP	NO
%HALO	100.00%
DATA ENT. JOB#	00

Program each item as follows:

- **RATE (Use the numeric entry)**
Percent rate (0.00 to 100.00)
- **TEXT (%) (Use the character entry)**
Description for the group discount key. Up to 8 characters can be entered.
- **TEXT (ST) (Use the character entry)**
Description for the group subtotal. Up to 8 characters can be entered.
- **SIGN (Use the selective entry)**
Programming of the + or – sign assigns the premium or discount function to each group discount key.
–: Minus (discount)
+: Plus (premium)
- **TAXABLE1 thru 4 (Use the selective entry)**
YES: Taxable
NO: Non-taxable
- **FOOD STAMP (Use the selective entry)**
Food stamp status
NO: Food stamp ineligible
YES: Food stamp eligible
- **%HALO (High Amount Lockout: use the numeric entry)**
HALO (High Amount Lockout) for the group discount key (0.00 to 100.00)
- **DATA ENT. JOB# (Use the numeric entry)**
Key data entry job number (Capture job no.: 0 thru 99)
When “0” is programmed, data entry is inhibited.

NOTE

You can also select a group discount key by pressing the corresponding key when it has been placed directly on the keyboard instead of selecting the key from the menu.

■ Gas discount

Procedure

Select the desired Gas discount (1 thru 19) from the list.

GAS(-)1	
PRICE(Cent)	0.0
TEXT	GAS(-)1
TEXT(ST)	GAS1 ST

Program each item as follows:

- **PRICE(Cent) (Use the numeric entry)**
Reduce unit price for each media (0.0 to 99.9 Cent)
- **TEXT (Use the character entry)**
Description for the gas discount. Up to 8 characters can be entered.
- **TEXT(ST) (Use the character entry)**
Description for the gas discount subtotal. Up to 8 characters can be entered.

■ Gratuity

Procedure

GRATUITY	↓
RATE	-0.00%
TEXT	GRATUITY
SIGN	-
TAXABLE1	NO
TAXABLE2	NO
TAXABLE3	NO

The screen continues.

Program each item as follows:

- **RATE (Use the numeric entry)**
Percent rate (0.00 to 100.00)
- **TEXT (Use the character entry)**
Description for the gratuity. Up to 8 characters can be entered.
- **SIGN (Use the selective entry)**
Programming of the + or – sign assigns the premium or discount function for the gratuity.
–: Minus (discount)
+: Plus (premium)
- **TAXABLE1 thru 4 (Use the selective entry)**
YES: Taxable
NO: Non-taxable
- **FOOD STAMP (Use the selective entry)**
Food stamp status
NO: Food stamp ineligible
YES: Food stamp eligible

■ Tip

Procedure

TIP	
RATE	0.00%
TEXT(CASH)	CA TIP
TEXT(CHR)	CH TIP
HALO	17

Program each item as follows:

- **RATE (Use the numeric entry)**
Percent rate (0.00 to 100.00)
- **TEXT(CASH) (Use the character entry)**
Description for the cash tip. Up to 8 characters can be entered.
- **TEXT(CHR) (Use the character entry)**
Description for the non-cash tip. Up to 8 characters can be entered.
- **HALO (High Amount Lockout: use the numeric entry)**
A: Significant digit for HALO (1 thru 9)
B: Number of zeros to follow the significant digit for HALO (0 thru 8)
AB is the same as $A \times 10^B$.

NOTE

You can also select a tip key by pressing the corresponding key when it has been placed directly on the keyboard instead of selecting the key from the menu.

■ RA

Procedure

Select the desired received-on-account key from the RA keys list.

```
***RA ↓
HALO 18
TEXT ***RA
DATA ENT. JOB# 00
CAT NOT COMPUL.
RESERVE ONLINE COMP.
RESERVED NO
```

Program each item as follows:

- **HALO (High Amount Lockout: use the numeric entry)**
 - A: Significant digit for HALO (1 thru 9)
 - B: Number of zeros to follow the significant digit for HALO (0 thru 8)
 - AB is the same as $A \times 10^B$.

- **TEXT (Use the character entry)**
 - Description for the received-on-account key. Up to 8 characters can be entered.

NOTE

You can also select an RA key by pressing the corresponding key when it has been placed directly on the keyboard instead of selecting the key from the menu.

- **DATA ENT. JOB# (Use the numeric entry)**
 - Key data entry job no. (Capture job no.: 0 thru 99)
 - When "0" is programmed, data entry is inhibited.
- **CAT (Use the selective entry)**
 - CAT programming (reserved/non-compulsory)
 - NOT COMPUL.
 - RESERVED
- **RESERVED (Use the selective entry)**
 - CARD RD COMP.
 - OFFLINE COMP.
 - ONLINE COMP.
- **RESERVED (Use the selective entry)**
 - NO
 - YES

■ PO

Procedure

Select the desired paid-out key from the PO keys list.

***PO

HALO		18
TEXT	***PO	
DATA ENT. JOB#		00

Program each item as follows:

- **HALO (High Amount Lockout: use the numeric entry)**

A: Significant digit for HALO (1 thru 9)

B: Number of zeros to follow the significant digit for HALO (0 thru 8)

AB is the same as $A \times 10^B$.

- **TEXT (Use the character entry)**

Description for the paid-out key. Up to 8 characters can be entered.

NOTE

You can also select a PO key by pressing the corresponding key when it has been placed directly on the keyboard instead of selecting the key from the menu.

- **DATA ENT. JOB# (Use the numeric entry)**

Key data entry job no. (Capture job no.: 0 thru 99)

When "0" is programmed, data entry is inhibited.

■ Manual tax

Procedure

MANUAL TAX

HALO		17
TEXT	M-TAX	
DATA ENT. JOB#		00

Program each item as follows:

- **HALO (High Amount Lockout: use the numeric entry)**

A: Significant digit for HALO (1 thru 9)

B: Number of zeros to follow the significant digit for HALO (0 thru 8)

AB is the same as $A \times 10^B$.

- **TEXT (Use the character entry)**

Description for the manual tax key. Up to 8 characters can be entered.

NOTE

You can also select the manual tax key by pressing the corresponding key when it has been placed directly on the keyboard instead of selecting the key from the menu.

- **DATA ENT. JOB# (Use the numeric entry)**

Key data entry job no. (Capture job no.: 0 thru 99)

When "0" is programmed, data entry is inhibited.

■ Tax delete

Procedure

TAX DELETE	
TEXT	TAX DEL.
DATA ENT. JOB#	00
a	

Program each item as follows:

- **TEXT (Use the character entry)**
Description for the tax delete.
Up to 8 characters can be entered.
- **DATA ENT. JOB# (Use the numeric entry)**
Key data entry job number (Capture job no.: 0 thru 99)
When "0" is programmed, data entry is inhibited.

■ No-sale

Procedure

NO SALE	
TEXT	NO SALE
DATA ENT. JOB#	00
a	

Program each item as follows:

- **TEXT (Use the character entry)**
Description for the no-sale.
Up to 8 characters can be entered.
- **DATA ENT. JOB# (Use the numeric entry)**
Key data entry job number (Capture job no.: 0 thru 99)
When "0" is programmed, data entry is inhibited.

■ Void

Procedure

Select the desired void function from the list (DIR VD/PAST VD/SBTL VD).

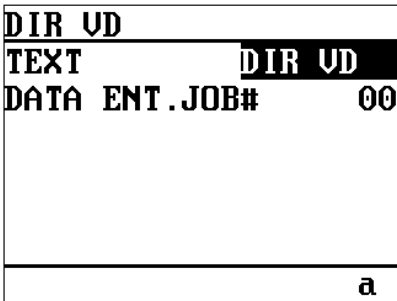

A terminal window showing the 'Void' function selection screen. The title bar reads 'DIR VD'. The main area contains the text 'TEXT DIR VD' and 'DATA ENT. JOB# 00'. A cursor is positioned at the end of the 'DATA ENT. JOB#' line. At the bottom right, there is a small 'a' icon.

Program each item as follows:

- **TEXT (Use the character entry)**
Description for the void function.
Up to 8 characters can be entered.
- **DATA ENT. JOB# (Use the numeric entry)**
Key data entry job no. (Capture job no.: 0 thru 99)
When "0" is programmed, data entry is inhibited.

■ Refund

Procedure

Select the refund or return function.

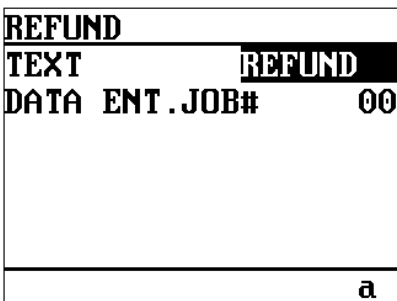

A terminal window showing the 'Refund' function selection screen. The title bar reads 'REFUND'. The main area contains the text 'TEXT REFUND' and 'DATA ENT. JOB# 00'. A cursor is positioned at the end of the 'DATA ENT. JOB#' line. At the bottom right, there is a small 'a' icon.

Program each item as follows:

- **TEXT (Use the character entry)**
Description for the refund or return function.
Up to 8 characters can be entered.
- **DATA ENT. JOB# (Use the numeric entry)**
Key data entry job no. (Capture job no.: 0 thru 99)
When "0" is programmed, data entry is inhibited.

Media Key Programming

Use the following procedure to select any option included in the media group:

Procedure

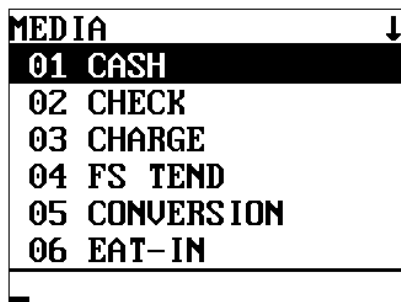
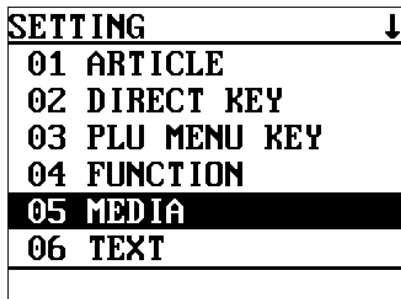

The screen continues.

1. In the SETTING window, select "05 MEDIA."
 - The MEDIA window will appear.

2. Select any option from the following options list:

1 CASH:	Cash key
2 CHECK:	Check key
3 CHARGE:	Charge key
4 FS TEND:	Food stamp tender key
5 CONVERSION:	Currency conversion keys
6 EAT-IN:	Eat-in key
7 SERVICE:	Service key
8 FINAL:	Final key
9 CID:	Cash in drawer
10 CH/CG:	Check change
11 CA/CK:	Check cashing

The following illustration shows those options included in the media key programming group.



■ Cash keys

Procedure

Select the desired cash key from the cash keys list.

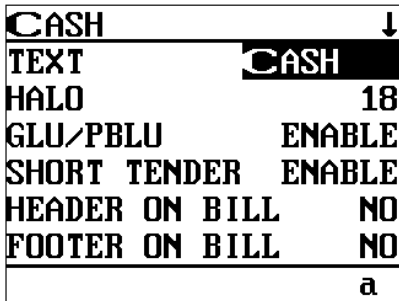

CASH	
TEXT	CASH
HALO	18
GLU/PBLU	ENABLE
SHORT TENDER	ENABLE
HEADER ON BILL	NO
FOOTER ON BILL	NO
	a

The screen continues.

Program each item as follows:

- **TEXT (Use the character entry)**
Description for the cash key. Up to 8 characters can be entered.
- **HALO (High Amount Lockout: use the numeric entry)**
AB is the same as $A \times 10^B$.
A: Significant digit (1 thru 9)
B: Number of zeros to follow the significant digit (0 thru 8)
You can set AB at 18 for no limitation.
- **GLU/PBLU (Use the selective entry)**
GLU/PBLU entry
COMPUL.: Makes the GLU/PBLU entry compulsory.
INHIBIT: Inhibits GLU/PBLU entry.
ENABLE: Enables GLU/PBLU entry.
- **SHORT TENDER (Use the selective entry)**
Short amount tender
DISABLE: Disables short amount tender.
ENABLE: Enables short amount tender.
- **HEADER ON BILL (Use the selective entry)**
YES: Enables header printing on the bill.
NO: Disables header printing on the bill.
- **FOOTER ON BILL (Use the selective entry)**
YES: Enables footer printing on the bill.
NO: Disables footer printing on the bill.
- **CLOSED GC (Use the selective entry)**
RETAIN.: Retains the closed GLU/PBLU summary data.
NO RETAIN.: Does not retain the closed GLU/PBLU summary data.
- **BILL PR. (Use the selective entry)**
Compulsory/non-compulsory bill printing
COMPUL.: Compulsory bill printing
NON-COMPUL.: Non-compulsory bill printing
- **FOOTER ON RCPT (Use the selective entry)**
This item decides whether or not your POS terminal should print a message at the foot of a receipt when a specified cash key is used.
YES: Enables footer printing on the receipt.
NO: Disables footer printing on the receipt.

■ Cash keys (continued)

- **NON ADD# (Use the selective entry)**

You can enforce the non-add code entry when a cash entry is accepted.

COMPUL.: Compulsory non-add code entry

NON-COMPUL.: Non-compulsory non-add code entry

- **NEG # CHECK (Use the selective entry)**

YES: Enables the negative # check function.

Any code (non-add code) existing in the negative # file is treated as invalid. The negative # check function can be overridden depending upon the programming.

NO: Disables the negative # check function.

- **POSITIVE # (Use the selective entry)**

YES: Enables the positive # check function.

Any code (non-add code) existing in the positive # file is treated as valid.

NO: Disables the positive # check function.

- **VP (Use the selective entry)**

COMPUL.: Compulsory validation printing

NON-COMPUL.: Non-compulsory validation printing

- **GAS DISCOUNT (Use the selective entry)**

YES: Enables gas discount.

NO: Disables gas discount.

- **TAX1 thru 4 DELETE (Use the selective entry)**

You can program each cash key to delete tax (i.e. tax 1, tax 2, tax 3, and tax 4) when it is pressed.

YES: Deletes Tax n (1 thru 4).

NO: Calculates Tax n (1 thru 4).

- **DRAWER OPENING (Use the selective entry)**

You can program each cash key to open the drawer.

NO: Disables the drawer opening.

YES: Opens the drawer.

- **AMOUNT (Use the selective entry)**

You may select compulsory or non-compulsory amount tender.

COMPUL.: Compulsory amount tendered entry

NON-COMPUL.: Non-compulsory amount tendered entry

- **OUTPUT KP No.1 thru No.3 (Use the numeric entry)**

ID number of the remote printer 1, 2 or 3 (1 digit: 1 to 9)

If the number "0" is entered, no items will be sent to the remote printer.

- **CHIT RECEIPT (Use the selective entry)**

YES: Prints on the chit receipt in the remote printer format.

NO: Prints nothing on the chit receipt.

- **DATA ENT. JOB# (Use the numeric entry)**

Key data entry job no. (Capture job no.: 0 thru 99)

When "0" is programmed, the data capture entry is inhibited.

■ Cash keys (continued)

- **CAT (Use the selective entry)**

You can select compulsory or non-compulsory CAT2/CAT1.

RESERVED.:

CAT#2 COMPUL.: Compulsory CAT2

CAT#1 COMPUL.: Compulsory CAT1

NOT COMPUL.: Non-compulsory CAT2/CAT1

- **CAT 1 (Use the selective entry)**

Select the ACTION CODE from the following items:

- RESERVED
- DIAL
- NOT TRANSMIT

- **CAT 2 (Use the selective entry)**

Select the ACTION CODE from the following items:

- AUTH-ONLY
- DIAL
- POST-AUTH

- **CAT2 (Use the selective entry)**

Select the transaction type.

- CHECK
- RESERVED
- CREDIT

- **RESERVED (Use the selective entry)**

- ONLINE COMP.
- OFFLINE COMP.
- CARD RD COMP.

- **RESERVED (Use the selective entry)**

- NO
- YES

- **RESERVED (Use the selective entry)**

- NO
- YES

- **CARD# PRT. (Use the selective entry)**

YES: Prints the card number.

NO: Does not print the card number.

- **CARD# FORMAT (Use the selective entry)**

FULL: Prints the entire card number.

PARTIAL: Prints only part of a card number.

- **SIGN.LINE PRT. (Use the selective entry)**

YES: Prints the signature line.

NO: Does not print the signature line.

■ Cash keys (continued)

- **CARD HOLD. PRT. (Use the selective entry)**

YES: Prints the name of the card holder.

NO: Does not print the name of the card holder.

- **EXPIRATION PRT. (Use the selective entry)**

YES: Prints the card expiration date.

NO: Does not print the card expiration date.

- **NUMBER OF RCPT (Use the numeric entry)**

Number of authorization receipts to be issued (1 digit: 1 to 9)

If the number "0" is entered, no authorization receipt is issued.

NOTE

You can also select a cash key by pressing the corresponding key when it has been placed directly on the keyboard instead of selecting the key from the menu.

■ Check keys

Procedure

Select the desired check key from the check keys list.

CHECK1		↓
TEXT	CHECK1	
HALO		18
GLU/PBLU	ENABLE	
SHORT TENDER	ENABLE	
HEADER ON BILL	NO	
FOOTER ON BILL	NO	
		a

The screen continues.

Program each item as follows:

- **TEXT (Use the character entry)**
Description for the check key. Up to 8 characters can be entered.
- **HALO (High Amount Lockout: use the numeric entry)**
AB is the same as $A \times 10^B$.
A: Significant digit (1 thru 9)
B: Number of zeros to follow the significant digit (0 thru 8)
You can set AB at 18 for no limitation.
- **GLU/PBLU (Use the selective entry)**
COMPUL.: Makes GLU/PBLU entry compulsory.
INHIBIT: Inhibits GLU/PBLU entry.
ENABLE: Enables GLU/PBLU entry.
- **SHORT TENDER (Use the selective entry)**
DISABLE: Disables short amount tender.
ENABLE: Enables short amount tender.
- **HEADER ON BILL (Use the selective entry)**
YES: Enables header printing on the bill.
NO: Disables header printing on the bill.
- **FOOTER ON BILL (Use the selective entry)**
YES: Enables footer printing on the bill.
NO: Disables footer printing on the bill.
- **CLOSED GC (Use the selective entry)**
RETAIN.: Retains the closed GLU/PBLU summary data.
NO RETAIN.: Does not retain the closed GLU/PBLU summary data.
- **BILL PR. (Use the selective entry)**
COMPUL.: Compulsory bill printing
NON-COMPUL.: Non-compulsory bill printing
- **FOOTER ON RCPT (Use the selective entry)**
YES: Enables footer printing on the receipt.
NO: Disables footer printing on the receipt.
- **NON ADD # (Use the selective entry)**
COMPUL.: Compulsory non-add code entry
NON-COMPUL.: Non-compulsory non-add code entry

■ Check keys (continued)

- **NEG # CHECK (Use the selective entry)**

YES: Enables the negative # check function.

Any code (non-add code) existing in the negative # file is treated as invalid. The negative # check function can be overridden depending upon the programming.

NO: Disables the negative # check function.

- **POSITIVE # (Use the selective entry)**

YES: Enables the positive # check function.

Any code (non-add code) existing in the positive # file is treated as valid.

NO: Disables the positive # check function.

- **CHANGE DUE (Use the selective entry)**

Either change enable or disable can be selected for each check key.

DISABLE: Disables change calculation.

ENABLE: Enables change calculation.

- **VP (Use the selective entry)**

COMPUL.: Compulsory validation printing

NON-COMPUL.: Non-compulsory validation printing

- **GAS DISCOUNT (Use the selective entry)**

YES: Enables gas discount.

NO: Disables gas discount.

- **TAX1 thru 4 DELETE (Use the selective entry)**

You can program each check key to delete tax (i.e. tax 1, tax 2, tax 3, and tax 4) when it is pressed.

YES: Deletes Tax n (1 thru 4).

NO: Calculates Tax n (1 thru 4).

- **DRAWER OPENING (Use the selective entry)**

NO: Disables the drawer opening.

YES: Opens the drawer.

- **AMOUNT (Use the selective entry)**

COMPUL.: Compulsory amount tendered entry

NON-COMPUL.: Non-compulsory amount tendered entry

- **OUTPUT KP No.1 thru 3 (Use the numeric entry)**

ID number of the remote printer 1, 2 or 3 (1 digit: 1 to 9)

If the number "0" is entered, no items will be sent to the remote printer.

- **CHIT RECEIPT (Use the selective entry)**

YES: Prints on the chit receipt in the remote printer format.

NO: Prints nothing on the chit receipt.

- **DATA ENT. JOB# (Use the numeric entry)**

Key data entry job no. (Capture job no.: 0 thru 99)

When "0" is programmed, the data capture entry is inhibited.

■ Check keys (continued)

- **CAT (Use the selective entry)**

CAT#2 COMPUL.: Compulsory CAT2

CAT#1 COMPUL.: Compulsory CAT1

NOT COMPUL.: Non-compulsory CAT2/CAT1

- **CAT 1 (Use the selective entry)**

Select the ACTION CODE from the following items:

- RESERVED
- DIAL
- NOT TRANSMIT

- **CAT 2 (Use the selective entry)**

Select the ACTION CODE from the following items:

- AUTH-ONLY
- DIAL
- POST-AUTH

- **CAT2 (Use the selective entry)**

Select the transaction type.

- CHECK
- RESERVED
- CREDIT

- **RESERVED (Use the selective entry)**

- ONLINE COMP.
- OFFLINE COMP.
- CARD RD COMP.

- **RESERVED (Use the selective entry)**

- NO
- YES

- **RESERVED (Use the selective entry)**

- NO
- YES

- **CARD# PRT. (Use the selective entry)**

YES: Prints the card number.

NO: Does not print the card number.

- **CARD# FORMAT (Use the selective entry)**

FULL: Prints the entire card number.

PARTIAL: Prints only part of a card number.

- **SIGN.LINE PRT. (Use the selective entry)**

YES: Prints the signature line.

NO: Does not print the signature line.

- **CARD HOLD. PRT. (Use the selective entry)**

YES: Prints the name of the card holder.

NO: Does not print the name of the card holder.

■ Check keys (continued)

- **EXPIRATION PRT. (Use the selective entry)**

YES: Prints the card expiration date.

NO: Does not print the card expiration date.

- **NUMBER OF RCPT (Use the numeric entry)**

Number of authorization receipts to be issued (1 digit: 1 to 9)

If the number "0" is entered, no authorization receipt is issued.

NOTE

You can also select a check key by pressing the corresponding key when it has been placed directly on the keyboard instead of selecting the key from the menu.

■ Charge keys

Procedure

Select the desired charge key from the charge keys list.

CHARGE1	↓
TEXT(GROSS) CHARGE1	
TEXT(REFUND CHARGE1-	
HALO	18
GLU/PBLU	ENABLE
SHORT TENDER	ENABLE
HEADER ON BILL	NO
	a

The screen continues.

Program each item as follows:

- **TEXT(GROSS) (Use the character entry)**
Description for the charge (gross sales) key. Up to 8 characters can be entered.
- **TEXT(REFUND) (Use the character entry)**
Description for the (refunded) charge key. Up to 8 characters can be entered.
- **HALO (High Amount Lockout: use the numeric entry)**
AB is the same as $A \times 10^B$.
A: Significant digit (1 thru 9)
B: Number of zeros to follow the significant digit (0 thru 8)
You can set AB at 18 for no limitation.
- **GLU/PBLU (Use the selective entry)**
COMPUL.: Makes GLU/PBLU entry compulsory.
INHIBIT: Inhibits GLU/PBLU entry.
ENABLE: Enables GLU/PBLU entry.
- **SHORT TENDER (Use the selective entry)**
DISABLE: Disables short amount tender.
ENABLE: Enables short amount tender.
- **HEADER ON BILL (Use the selective entry)**
YES: Enables header printing on the bill.
NO: Disables header printing on the bill.
- **FOOTER ON BILL (Use the selective entry)**
YES: Enables footer printing on the bill.
NO: Disables footer printing on the bill.
- **CLOSED GC (Use the selective entry)**
RETAIN.: Retains the closed GLU/PBLU summary data.
NO RETAIN.: Does not retain the closed GLU/PBLU summary data.
- **BILL PR. (Use the selective entry)**
Compulsory/non-compulsory bill printing
COMPUL.: Compulsory bill printing
NON-COMPUL.: Non-compulsory bill printing
- **FOOTER ON RCPT (Use the selective entry)**
YES: Enables footer printing on the receipt.
NO: Disables footer printing on the receipt.
- **NON ADD # (Use the selective entry)**
COMPUL.: Compulsory non-add code entry
NON-COMPUL.: Non-compulsory non-add code entry

■ Charge keys (continued)

- **NEG # CHECK (Use the selective entry)**

YES: Enables the negative # check function.

Any code (non-add code) existing in the negative # file is treated as invalid. The negative # check function can be overridden depending upon the programming.

NO: Disables the negative # check function.

- **POSITIVE # (Use the selective entry)**

YES: Enables the positive # check function.

Any code (non-add code) existing in the positive # file is treated as valid.

NO: Disables the positive # check function.

- **CHANGE DUE (Use the selective entry)**

Either change enable or disable can be selected for each check key.

DISABLE: Disables change calculation.

ENABLE: Enables change calculation.

- **VP (Use the selective entry)**

COMPUL.: Compulsory validation printing

NON-COMPUL.: Non-compulsory validation printing

- **GAS DISCOUNT (Use the selective entry)**

YES: Enables gas discount.

NO: Disables gas discount.

- **TAX1 thru 4 DELETE (Use the selective entry)**

You can program each check key to delete tax (i.e. tax 1, tax 2, tax 3, and tax 4) when it is pressed.

YES: Deletes Tax n (1 thru 4).

NO: Calculates Tax n (1 thru 4).

- **DRAWER OPENING (Use the selective entry)**

NO: Disables the drawer opening.

YES: Opens the drawer.

- **AMOUNT (Use the selective entry)**

COMPUL.: Compulsory amount tendered entry

INHIBIT: Inhibit amount tendered entry

- **OUTPUT KP No.1 thru 3 (Use the numeric entry)**

ID number of the remote printer 1, 2 or 3 (1 digit: 1 to 9)

If the number "0" is entered, no items will be sent to the remote printer.

- **CHIT RECEIPT (Use the selective entry)**

YES: Prints on the chit receipt in the remote printer format.

NO: Prints nothing on the chit receipt.

- **DATA ENT. JOB# (Use the numeric entry)**

Key data entry job no. (Capture job no.: 0 thru 99)

When "0" is programmed, the data capture entry is inhibited.

■ Charge keys (continued)

- **CAT (Use the selective entry)**

RESERVED:

CAT#2 COMPUL.: Compulsory CAT2

CAT#1 COMPUL.: Compulsory CAT1

NOT COMPUL.: Non-compulsory CAT2/CAT1

- **CAT 1 (Use the selective entry)**

Select the ACTION CODE from the following items:

- RESERVED
- DIAL
- NOT TRANSMIT

- **CAT 2 (Use the selective entry)**

Select the ACTION CODE from the following items:

- AUTH-ONLY
- DIAL
- POST-AUTH

- **CAT2 (Use the selective entry)**

Select the transaction type.

- CHECK
- RESERVED
- CREDIT

- **RESERVED (Use the selective entry)**

- ONLINE COMP.
- OFFLINE COMP.
- CARD RD COMP.

- **RESERVED (Use the selective entry)**

- NO
- YES

- **RESERVED (Use the selective entry)**

- NO
- YES

- **CARD# PRT. (Use the selective entry)**

YES: Prints the card number.

NO: Does not print the card number.

- **CARD# FORMAT (Use the selective entry)**

FULL: Prints the entire card number.

PARTIAL: Prints only part of a card number.

- **SIGN.LINE PRT. (Use the selective entry)**

YES: Prints the signature line.

NO: Does not print the signature line.

- **CARD HOLD. PRT. (Use the selective entry)**

YES: Prints the name of the card holder.

NO: Does not print the name of the card holder.

■ Charge keys (continued)

- **EXPIRATION PRT. (Use the selective entry)**

YES: Prints the card expiration date.

NO: Does not print the card expiration date.

- **NUMBER OF RCPT (Use the numeric entry)**

Number of authorization receipts to be issued (1 digit: 1 to 9)

If the number "0" is entered, no authorization receipt is issued.

NOTE

You can also select a charge key by pressing the corresponding key when it has been placed directly on the keyboard instead of selecting the key from the menu.

■ Food stamp tender key

Procedure

FS TEND	↓
TEXT	FS TEND
GLU/PBLU	ENABLE
HEADER ON BILL	NO
FOOTER ON BILL	NO
CLOSED GC NO RETAIN.	
BILL PR. NON-COMPUL.	
	a

The screen continues.

Program each item as follows:

- **TEXT (Use the character entry)**
Description for the check key. Up to 8 characters can be entered.
- **GLU/PBLU (Use the selective entry)**
COMPUL.: Makes GLU/PBLU entry compulsory.
INHIBIT: Inhibits GLU/PBLU entry.
ENABLE: Enables GLU/PBLU entry.
- **HEADER ON BILL (Use the selective entry)**
YES: Enables header printing on the bill.
NO: Disables header printing on the bill.
- **FOOTER ON BILL (Use the selective entry)**
YES: Enables footer printing on the bill.
NO: Disables footer printing on the bill.
- **CLOSED GC (Use the selective entry)**
RETAIN.: Retains the closed GLU/PBLU summary data.
NO RETAIN.: Does not retain the closed GLU/PBLU summary data.
- **BILL PR. (Use the selective entry)**
COMPUL.: Compulsory bill printing
NON-COMPUL.: Non-compulsory bill printing
- **FOOTER ON RCPT (Use the selective entry)**
YES: Enables footer printing on the receipt.
NO: Disables footer printing on the receipt.
- **NON ADD # (Use the selective entry)**
COMPUL.: Compulsory non-add code entry
NON-COMPUL.: Non-compulsory non-add code entry
- **NEG # CHECK (Use the selective entry)**
YES: Enables the negative # check function.
Any code (non-add code) existing in the negative # file is treated as invalid. The negative # check function can be overridden depending upon the programming.
NO: Disables the negative # check function.

■ Food stamp tender key (continued)

- **POSITIVE # (Use the selective entry)**

YES: Enables the positive # check function.

Any code (non-add code) existing in the positive # file is treated as valid.

NO: Disables the positive # check function.

- **VP (Use the selective entry)**

COMPUL.: Compulsory validation printing

NON-COMPUL.: Non-compulsory validation printing

- **DRAWER OPENING (Use the selective entry)**

NO: Disables the drawer opening.

YES: Opens the drawer.

- **OUTPUT KP No.1 thru 3 (Use the numeric entry)**

ID number of the remote printer 1, 2 or 3 (1 digit: 1 to 9)

If the number "0" is entered, no items will be sent to the remote printer.

- **CHIT RECEIPT (Use the selective entry)**

YES: Prints on the chit receipt in the remote printer format.

NO: Prints nothing on the chit receipt.

- **DATA ENT. JOB# (Use the numeric entry)**

Key data entry job no. (Capture job no.: 0 thru 99)

When "0" is programmed, the data capture entry is inhibited.

NOTE

You can also select a food stamp tender key by pressing the corresponding key when it has been placed directly on the keyboard instead of selecting the key from the menu.

■ Currency conversion keys

Procedure

Select the desired currency conversion key from the currency conversion keys list.

CONV 1	
RATE	0.0000
TEXT	CONV 1
DESCRIPTOR	

Program each item as follows:

- **RATE (Use the numeric entry)**
Currency conversion rate (0.0000 to 9999.9999) (for CONV1 thru CONV3)
- **TEXT (Use the character entry)**
Description for the currency conversion key. Up to 8 characters can be entered.
- **DESCRIPTOR (Use the character entry)**
Currency descriptor. Up to 4 characters can be entered.

NOTE

You can also select a conversion key by pressing the corresponding key when it has been placed directly on the keyboard instead of selecting the key from the menu.

■ Eat-in keys

Procedure

Select the desired eat-in key from the eat-in keys list.

EAT IN 1	
TEXT	EAT IN 1
TAX1 DELETE	NO
TAX2 DELETE	NO
TAX3 DELETE	NO
TAX4 DELETE	NO
a	

Program each item as follows:

- **TEXT (Use the character entry)**
Description for the eat-in key. Up to 8 characters can be entered.
- **TAX1 thru 4 DELETE (Use the selective entry)**
YES: Deletes Tax n (1 thru 4).
NO: Calculates Tax n (1 thru 4).

NOTE

You can also select an eat-in key by pressing the corresponding key when it has been placed directly on the keyboard instead of selecting the key from the menu.

■ Service key

Procedure

SERVICE		↓
TEXT (GLU)		SERVICE
HEADER ON BILL		NO
FOOTER ON BILL		NO
BILL PR. NON-COMPUL.		
OUTPUT KP No.1		0
OUTPUT KP No.2		0
		a

The screen continues.

Program each item as follows:

- **TEXT (GLU) (Use the character entry)**
Description for the service key. Up to 8 characters can be entered.
- **HEADER ON BILL (Use the selective entry)**
YES: Enables header printing on the bill.
NO: Disables header printing on the bill.
- **FOOTER ON BILL (Use the selective entry)**
YES: Enables footer printing on the bill.
NO: Disables footer printing on the bill.
- **BILL PR. (Use the selective entry)**
COMPUL.: Compulsory bill printing
NON-COMPUL.: Non-compulsory bill printing
- **OUTPUT KP No.1 thru 3 (Use the selective entry)**
ID number of the remote printer 1, 2 or 3 (1 digit: 1 to 9)
If the number "0" is entered, data will be printed at the remote printer.
- **CHIT RECEIPT (Use the selective entry)**
YES: Prints on the chit receipt in the remote printer format.
NO: Prints nothing on the chit receipt.
- **DATA ENT. JOB# (Use the numeric entry)**
Key data entry job no. (Capture job no.: 0 thru 99)
When "0" is programmed, the data capture entry is inhibited.
- **CAT (Use the selective entry)**
RESERVED:
CAT#2 COMPUL.: Compulsory CAT2
CAT#1 COMPUL.: Compulsory CAT1
NOT COMPUL.: Non-compulsory CAT2/CAT1
- **CAT 1 (Use the selective entry)**
Select the ACTION CODE from the following items:
 - RESERVED
 - DIAL
 - NOT TRANSMIT
- **CAT 2 (Use the selective entry)**
Select the ACTION CODE from the following items:
 - POST-AUTH
 - DIAL
 - AUTH-ONLY

■ Service key (continued)

- **CAT2 (Use the selective entry)**

Select the transaction type.

- CHECK
- RESERVED
- CREDIT

- **RESERVED (Use the selective entry)**

- ONLINE COMP.
- OFFLINE COMP.
- CARD RD COMP.

- **RESERVED (Use the selective entry)**

- NO
- YES

- **RESERVED (Use the selective entry)**

- NO
- YES

- **CARD# PRT. (Use the selective entry)**

YES: Prints the card number.

NO: Does not print the card number.

- **CARD# FORMAT (Use the selective entry)**

FULL: Prints the entire card number.

PARTIAL: Prints only part of a card number.

- **SIGN.LINE PRT. (Use the selective entry)**

YES: Prints the signature line.

NO: Does not print the signature line.

- **CARD HOLD. PRT. (Use the selective entry)**

YES: Prints the name of the card holder.

NO: Does not print the name of the card holder.

- **EXPIRATION PRT. (Use the selective entry)**

YES: Prints the card expiration date.

NO: Does not print the card expiration date.

- **NUMBER OF RCPT (Use the numeric entry)**

Number of authorization receipts to be issued (1 digit: 1 to 9)

If the number "0" is entered, no authorization receipt is issued.

NOTE

You can also select the service key by pressing the corresponding key when it has been placed directly on the keyboard instead of selecting the key from the menu.

■ Final key

Procedure

FINAL	↓
HEADER ON BILL	NO
FOOTER ON BILL	NO
BILL PR. NON-COMPUL.	
OUTPUT KP No.1	0
OUTPUT KP No.2	0
OUTPUT KP No.3	0

The screen continues.

Program each item as follows:

- **HEADER ON BILL (Use the selective entry)**
 - YES: Enables header printing on the bill.
 - NO: Disables header printing on the bill.
- **FOOTER ON BILL (Use the selective entry)**
 - YES: Enables footer printing on the bill.
 - NO: Disables footer printing on the bill.
- **BILL PR. (Use the selective entry)**
 - COMPUL.: Compulsory bill printing
 - NON-COMPUL.: Non-compulsory bill printing
- **OUTPUT KP No.1 thru 3 (Use the number entry)**
 - ID number of the remote printer 1, 2 or 3 (1 digit: 1 to 9)
 - If the number "0" is entered, data will be printed at the remote printer.
- **CHIT RECEIPT (Use the selective entry)**
 - YES: Prints on the chit receipt in the remote printer format.
 - NO: Prints nothing on the chit receipt.
- **DATA ENT. JOB# (Use the numeric entry)**
 - Key data entry job no. (Capture job no.: 0 thru 99)
 - When "0" is programmed, the data capture entry is inhibited.
- **CAT (Use the selective entry)**
 - RESERVED:
 - CAT#2 COMPUL.: Compulsory CAT2
 - CAT#1 COMPUL.: Compulsory CAT1
 - NOT COMPUL.: Non-compulsory CAT2/CAT1
- **CAT 1 (Use the selective entry)**
 - Select the ACTION CODE from the following items:
 - RESERVED
 - DIAL
 - NOT TRANSMIT
- **CAT 2 (Use the selective entry)**
 - Select the ACTION CODE from the following items:
 - POST-AUTH
 - DIAL
 - AUTH-ONLY
- **CAT2 (Use the selective entry)**
 - Select the transaction type.
 - CREDIT
 - RESERVED
 - CHECK

■ Final key (continued)

- **RESERVED (Use the selective entry)**
 - ONLINE COMP.
 - OFFLINE COMP.
 - CARD RD COMP.

- **RESERVED (Use the selective entry)**
 - NO
 - YES

- **RESERVED (Use the selective entry)**
 - NO
 - YES

- **CARD# PRT. (Use the selective entry)**
 - YES: Prints the card number.
 - NO: Does not print the card number.

- **CARD# FORMAT (Use the selective entry)**
 - FULL: Prints the entire card number.
 - PARTIAL: Prints only part of a card number.

- **SIGN.LINE PRT. (Use the selective entry)**
 - YES: Prints the signature line.
 - NO: Does not print the signature line.

- **CARD HOLD. PRT. (Use the selective entry)**
 - YES: Prints the name of the card holder.
 - NO: Does not print the name of the card holder.

- **EXPIRATION PRT. (Use the selective entry)**
 - YES: Prints the card expiration date.
 - NO: Does not print the card expiration date.

- **NUMBER OF RCPT (Use the numeric entry)**
 - Number of authorization receipts to be issued (1 digit: 1 to 9)
 - If the number "0" is entered, no authorization receipt is issued.

NOTE

You can also select the final key by pressing the corresponding key when it has been placed directly on the keyboard instead of selecting the key from the menu.

■ Cash in drawer

You can program the description and the upper limit amounts for cash in drawer (sentinel).

Procedure

CID	
TEXT	XXXXXXXXCID
HALO	9999999.99
a	

Program each item as follows:

- **TEXT (Use the character entry)**
Description for the cash in drawer. Up to 8 characters can be entered.
- **HALO (High Amount Lockout: used the numeric entry)**
Limit amount: 0 to 9999999.99

■ Check change

You can program the description and the upper limit amounts for check change.

Procedure

CH/CG	
TEXT	CHK/CG
HALO	999999.99
a	

Program each item as follows:

- **TEXT (Use the character entry)**
Description for check change. Up to 8 characters can be entered.
- **HALO (High Amount Lockout: used the numeric entry)**
Limit amount: 0 to 999999.99

■ Check cashing

You can program the description and the upper limit amounts for check cashing.

Procedure

Select the desired check cashing no. from the check cashing numbers list.

```
CA/CHK1 ↓
TEXT      CA/CHK1
HALO      999999.99
CAT       NOT COMPUL.
CAT1      NOT TRANSMIT
CAT2      POST-AUTH
CAT2      CREDIT
a
```

The screen continues.

Program each item as follows:

- **TEXT (Use the character entry)**
Description for check cashing. Up to 8 characters can be entered.
- **HALO (High Amount Lockout: used the numeric entry)**
Limit amount: 0 to 999999.99
- **CAT (Use the selective entry)**
CAT#2 COMPUL.: Compulsory CAT2
CAT#1 COMPUL.: Compulsory CAT1
NOT COMPUL.: Non-compulsory CAT2/CAT1
- **CAT 1 (Use the selective entry)**
Select the ACTION CODE from the following items:
 - RESERVED
 - DIAL
 - NOT TRANSMIT
- **CAT 2 (Use the selective entry)**
Select the ACTION CODE from the following items:
 - POST-AUTH
 - DIAL
 - AUTH-ONLY
- **CAT2 (Use the selective entry)**
Select the transaction type.
 - CREDIT
 - RESERVED
 - CHECK
- **CARD# PRT. (Use the selective entry)**
YES: Prints the card number.
NO: Does not print the card number.
- **CARD# FORMAT (Use the selective entry)**
FULL: Prints the entire card number.
PARTIAL: Prints only part of a card number.
- **SIGN.LINE PRT. (Use the selective entry)**
YES: Prints the signature line.
NO: Does not print the signature line.
- **CARD HOLD. PRT (Use the selective entry)**
YES: Prints the name of the card holder.
NO: Does not print the name of the card holder.

■ Check cashing (continued)

- **EXPIRATION PRT (Use the selective entry)**

YES: Prints the card expiration date.

NO: Does not print the card expiration date.

- **NUMBER OF RCPT (Use the numeric entry)**

Number of authorization receipts to be issued (1 digit: 1 to 9)

If the number "0" is entered, no authorization receipt is issued.

Text Programming

Use the following procedure to select any option included in the text group:

Procedure

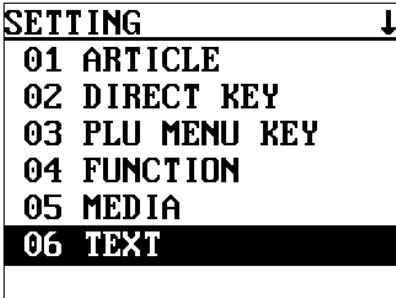

SETTING ↓

- 01 ARTICLE
- 02 DIRECT KEY
- 03 PLU MENU KEY
- 04 FUNCTION
- 05 MEDIA
- 06 TEXT**

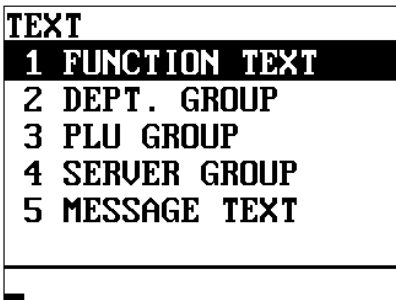

TEXT

- 1 FUNCTION TEXT**
- 2 DEPT. GROUP
- 3 PLU GROUP
- 4 SERVER GROUP
- 5 MESSAGE TEXT

1. In the SETTING window, select “06 TEXT.”
 - The TEXT window will appear.

2. Select any option from the following options list:

1 FUNCTION TEXT:	Function text
2 DEPT. GROUP:	Department group text
3 PLU GROUP:	PLU group text
4 SERVER GROUP:	Server group text
5 MESSAGE TEXT:	Message text

The following illustration shows those options included in the text programming group.

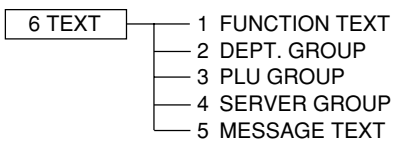

- ➔ See “Function text” on page [151](#).
- ➔ See “Department group text” on page [153](#).
- ➔ See “PLU group text” on page [153](#).
- ➔ See “Server group text” on page [154](#).
- ➔ See “Message text” on page [154](#).

■ Function text

You can program a maximum of eight characters for each function by using the following table:

Procedure

FUNCTION TEXT	↓
001	NET 1
002	TAX1 ST
003	GRS TAX1
004	RFD TAX1
005	TAX1
006	TX1 EXPT

The screen continues.

Function no.	Function	Default text
001	Net sales total	NET 1
002	Net taxable 1 subtotal	TAX1 ST
003	Gross tax 1 total	GRS TAX1
004	Tax 1 total of refund entries	RFD TAX1
005	Net tax 1 total	TAX1
006	Exempt tax 1	TX1 EXPT
007	Net taxable 2 subtotal	TAX2 ST
008	Gross tax 2 total	GRS TAX2
009	Tax 2 total of refund entries	RFD TAX2
010	Net tax 2 total	TAX2
011	Exempt tax 2	TX2 EXPT
012	Net taxable 3 subtotal	TAX3 ST
013	Gross tax 3 total	GRS TAX3
014	Tax 3 total of refund entries	RFD TAX3
015	Net tax 3 total	TAX3
016	Exempt tax 3	TX3 EXPT
017	Net taxable 4 subtotal	TAX4 ST
018	Gross tax 4 total	GRS TAX4
019	Tax 4 total of refund entries	RFD TAX4
020	Net tax 4 total	TAX4
021	Exempt tax 4	TX4 EXPT
022	Gross manual tax total	GRS MTAX
023	Refund manual tax total	RFD MTAX
024	Exempt total from GST	GST EXPT
025	PST total	PST TTL
026	GST total	GST TTL
027	Tax total	TTL TAX
028	Tax 1 forgiveness total	FS TX1

Function no.	Function	Default text
029	Tax 2 forgiveness total	FS TX2
030	Tax 3 forgiveness total	FS TX3
031	Net	NET
032	Sales total including tax total	NET 2
033	COMBO 1 (for transaction report)	COMBO1
034	COMBO 2 (for transaction report)	COMBO2
035	COMBO 3 (for transaction report)	COMBO3
036	COMBO 4 (for transaction report)	COMBO4
037	COMBO 5 (for transaction report)	COMBO5
038	COMBO 6 (for transaction report)	COMBO6
039	COMBO 7 (for transaction report)	COMBO7
040	COMBO 8 (for transaction report)	COMBO8
041	COMBO 9 (for transaction report)	COMBO9
042	COMBO 10 (for transaction report)	COMBO10
043	COMBO 11 (for transaction report)	COMBO11
044	COMBO 12 (for transaction report)	COMBO12
045	COMBO 13 (for transaction report)	COMBO13
046	COMBO 14 (for transaction report)	COMBO14
047	COMBO 15 (for transaction report)	COMBO15
048	COMBO 16 (for transaction report)	COMBO16
049	COMBO 17 (for transaction report)	COMBO17
050	COMBO 18 (for transaction report)	COMBO18
051	COMBO 19 (for transaction report)	COMBO19
052	COMBO 20 (for transaction report)	COMBO20
053	Coupon-like PLU	CP PLU
054	Vender coupon UPC	V. CP UPC
055	Manager void	MGR VD
056	Void mode	VOID

■ Function text (continued)

Function no.	Function	Default text
057	Hash direct void	HASH VD
058	Hash past void	HA P.VD
059	Hash item refund	HASH RF
060	Hash item return	HASH RT
061	Validation print counter	VP CNT
062	Bill count	BILL CNT
063	Tray counter	TRAY CNT
064	Drawer counter	DRW CNT
065	Transfer out	TRAN.OUT
066	Transfer in	TRAN.IN
067	Previous balance (for GLU)	***PBAL
068	Cover count	COVER CT
069	Customer counter	TRANS CT
070	Sales total	NET 3
071	Hash net total	HASH TTL
072	Food stamp change (cash)	FS/CG
073	Cash+check in drawer	CA+CH ID
074	Food stamp in drawer	FS ID
075	Deposit	DEPOSIT
076	Deposit refund	DPST RF
077	Tip paid	TIP PAID
078	(+) dept. total	*DEPT TL
079	(-) dept. total	DEPT(-)
080	Hash (+) dept. total	*HASH TL
081	Hash (-) dept. total	HASH(-)
082	Bottle (+) dept. total	*BTTL TL
083	Bottle (-) dept. total	BTTL(-)
084	Gasoline (+) dept. total	*GAS TL
085	Gasoline (-) dept. total	GAS(-)
086	Subtotal	SUBTOTAL
087	Merchandise subtotal	MDSE ST
088	Total	***TOTAL
089	Change	CHANGE
090	Due	DUE
091	Tip due	TIP DUE
092	Tray total	TRAY TL
093	Food stamp subtotal	FS ST
094	Food stamp tender	FS TEND
095	Food stamp change	FS CG
096	Items	ITEMS
097	Customer charge	CHARGE
098	Balance	BALANCE

Function no.	Function	Default text
099	Copy	COPY
100	B.T. title	B.T.
101	B.S. title	B.S.
102	Slip print message	SLIP PR.
103	Final balance	FIN.BAL
104	Balance forward	BAL FWD
105	Close check	CLOSE CK
106	Open check	OPEN CK
107	Percent of net sales	(%)SALES
108	Seat code	SEAT#
109	Exempt VAT	VAT EXP
110	Individual payment	IND.PAY
111	Tare weight	TARE WT.
112	Receipt switch	RCP S.W.
113	Free GLU	FREE GLU
114	WASTE title	WASTE
115	Average sales	AVE SALE
116	ST(-) total	ST(-) TL
117	ST% total	ST % TL
118	Item(-) total	(-) TL
119	Item% total	% TL
120	Group discount % total	GDISC%TL
121	Gas discount total	GASDISTL
122	CASH total	CASH TL
123	RA total	RA TL
124	PO total	PO TL
125	CA/CK total	CA/CK TL
126	CONV total	CONV TL
127	CHARGE total	CHR TL
128	CHECK total	CHECK TL
129	COMBO (for PLU report)	COMBO
130	WASTE (for PLU report)	WASTE
131	RF (for PLU report)	RF
132	CP (for PLU report)	CP
133	NET SLS (for PLU report)	NET SLS
134	COMBO TL (for PLU report)	COMBO TL
135	WASTE TL (for PLU report)	WASTE TL
136	RF TL (for PLU report)	RF TL
137	NET TL (for PLU report)	NET TL
138	GLU text	TBL#
139	Server sign-on text	SIGN-ON
140	Server sign-off text	SIGN-OFF

■ Department group text

You can program a maximum of eight characters for each department group (1~9).

Procedure

Select the desired department group number from the department groups list.

A terminal window showing the text 'DPT GR-1' in the top left corner and 'DPT GR-1' in the top right corner. A cursor 'a' is visible at the bottom right of the window.

Program the item as follows:

- **TEXT (Use the character entry)**

Description for the department group. Up to 8 characters can be entered.

■ PLU group text

You can program a maximum of eight characters for each PLU group (1~99).

Procedure

Select the desired PLU group number from the PLU groups list.

A terminal window showing the text 'PLU GR01' in the top left corner and 'PLU GR01' in the top right corner. A cursor 'a' is visible at the bottom right of the window.

Program the item as follows:

- **TEXT (Use the character entry)**

Description for the PLU group. Up to 8 characters can be entered.

■ Server group text

You can program a maximum of eight characters for each server group (1~9).

Procedure

Select the desired server group no. from the server groups list.

GROUP1

GROUP1

a

Program the item as follows:

- **TEXT (Use the character entry)**

Description for the server group. Up to 8 characters can be entered.

■ Message text

You can program a message consisting of a maximum of 16 characters for each remote printer.

Procedure

Select the desired message no. from the message list.

MESSAGE1

MESSAGE 1

REMOTE PRINTER 0

PRINT LOCATION TOP

a

Program each item as follows:

- **TEXT (Use the character entry)**

Description for a remote printer message. Up to 16 characters can be entered,

- **REMOTE PRINTER (Use the numeric entry)**

Remote printer number (1 - 9/0)

- **PRINT LOCATION (Use the selective entry)**

TOP: Prints the message at the top of a remote printer receipt.

BOTTOM: Prints the message at the bottom of a remote printer receipt.

Personnel Programming

Use the following procedure to select any option included in the personnel group:

■ Server

Procedure

```

SETTING      ↑↓
07 PERSONNEL
08 TERMINAL
09 DATE/TIME
10 OPTIONAL
11 SECRET CODE
12 REPORT
    
```



```

PERSONNEL
1 SERVER
    
```



```

SERUER      ↓
0001 SERV.001
0002 SERV.002
0003 SERV.003
0004 SERV.004
0005 SERV.005
0006 SERV.006
    
```



```

0001
SECRET CODE      0000
NAME             SERV.001
ENTRY            NON-COMPUL.
DRAWER#         1
NET SALES%      0.00%
    
```

1. In the SETTING window, select "07 PERSONNEL."
 - The PERSONNEL window will appear.

2. Select the server options.

Program each item as follows:

- **SECRET CODE (Use the numeric entry)**
Secret code (max. 4 digits: 0001 to 9999/0000)
- **NAME (Use the character entry)**
Name for the server. Up to 8 characters can be entered.
- **ENTRY (Use the selective entry)**
GLU(PBLU): Compulsory GLU(PBLU)
NON-COMPUL.: Non-compulsory GLU(PBLU)
- **DRAWER# (Use the numeric entry)**
Drawer number (1 or 2/0)
- **NET SALES% (Use the numeric entry)**
Net sales percent rate (max. 5 digits: 0.00 to 100.00)

Terminal Programming

Use the following procedure to select any option included in the terminal group:

Procedure

SETTING	↑↓
07 PERSONNEL	
08 TERMINAL	
09 DATE/TIME	
10 OPTIONAL	
11 SECRET CODE	
12 REPORT	



TERMINAL
1 MACHINE#
2 CONSECUTIVE#
3 INTERVAL TIMER
4 DEF. MENU LEVEL
5 AVAILABLE GLU#
6 BILL NUMBER

1. In the SETTING window, select “08 TERMINAL.”

- The TERMINAL window will appear.

2. Select any option from the following options list:

1 MACHINE#:	Machine number
2 CONSECUTIVE#:	Consecutive number
3 INTERVAL TIMER:	Interval timer
4 DEF. MENU LEVEL	Default menu level
5 AVAILABLE GLU#	Available GLU code
6 BILL NUMBER	Bill number

The following illustration shows those options included in the terminal programming group.

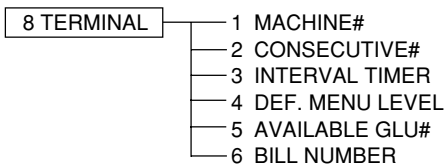

- ➔ See “Machine number” on page [157](#).
- ➔ See “Consecutive number” on page [157](#).
- ➔ See “Interval timer” on page [157](#).
- ➔ See “Default menu level” on page [158](#).
- ➔ See “Available GLU code” on page [158](#).
- ➔ See “Bill number” on page [158](#).

■ Machine number

When your store has two or more POS terminals, it is practical to assign them unique machine numbers for their identification.

Procedure

MACHINE#	
MACHINE#	000000

Program the item as follows:

- **MACHINE# (Use the numeric entry)**
Machine number (max. 6 digits: 0 to 999999)

■ Consecutive number

The consecutive number is increased by one each time a receipt is issued.

Procedure

CONSECUTIVE#	
CONSECUTIVE#	0000

Program the item as follows:

- **CONSECUTIVE# (Use the numeric entry)**
Enter a number (max. 4 digits: 0 to 9999) that is one less than the desired starting number.

■ Interval timer

You can program the timer for THE TILL TIMER™ and the screen save mode timer.

Procedure

INTERVAL TIMER	
TILL TIMER	000
SCREEN SAVE	00

Program each item as follows:

- **TILL TIMER (Use the numeric entry)**
The POS terminal counts the number of times the drawer is left open for longer than a programmed time limit. The counter will be incremented by one each time a programmed time limit is reached. The time limit for THE TILL TIMER™ can be preset for 0 to 255 seconds. The count is printed on the transaction report and server report. If the number "0" is entered, this function is unavailable.
- **SCREEN SAVE (Use the numeric entry)**
Screen save mode timer (max. 2 digits: 0 to 99 minutes)
If the number "0" is entered, the POS terminal will turn the display off after 100 min., if the POS terminal remains idle.

■ Default menu level

You can preset the menu level to be returned after item entry.

Procedure

DEF.MENU LEVEL	
DEF.MENU LEVEL	1

Program the item as follows:

- **DEF. MENU LEVEL (Use the numeric entry)**
Default menu level (1 to 5)

■ Available GLU code

You can specify the range of GLU numbers available for each terminal.

Procedure

AVAILABLE GLU#	
START CODE	0001
END CODE	9999

Program the item as follows:

- **START CODE (Use the numeric entry)**
Start GLU/PBLU code (max. 4 digits: 1 to 9999)
- **END CODE (Use the numeric entry)**
End GLU/PBLU code (max. 4 digits: 1 to 9999)

■ Bill number

A consecutive bill number is automatically increased each time a GLU entry is finalized.

Procedure

BILL NUMBER	
BILL NUMBER	0000

Program the item as follows:

- **BILL NUMBER (Use the numeric entry)**
Enter a number (max. 4 digits: 0 to 9999) that is one less than a desired starting number.

Date/Time Setting

Use the following procedure to select the menu option "09 DATE/TIME":

■ Date/time

You can set the date and time for the POS terminal.

Procedure

SETTING	↑↓
07 PERSONNEL	
08 TERMINAL	
09 DATE/TIME	
10 OPTIONAL	
11 SECRET CODE	
12 REPORT	



DATE/TIME	
DATE	010100
TIME	0000

Set each item as follows:

- **DATE (Use the numeric entry)**

Enter the month (2 digits), day (2 digits), and year (2 digits) in this sequence.

- **TIME (Use the numeric entry)**

Set the time (max. 4 digits) on the military time (24-hour) system. For example, when the time is set to 2:30 AM, enter 0230; and when it is set to 2:30 PM, enter 1430. The time will be printed and displayed on the real-time system. Once you set the time, the internal clock unit will continue to run as long as the battery pack is charged and also update the date (month, day, year) when required.

Optional Feature Selection

Use the following procedure to select any option included in the optional group:

Procedure

SETTING	↑↓
07 PERSONNEL	
08 TERMINAL	
09 DATE/TIME	
10 OPTIONAL	
11 SECRET CODE	
12 REPORT	



OPTIONAL
1 FUNC.PROHIBIT
2 FUNC.SELECT1
3 FUNC.SELECT2
4 PRINT SELECT

1. In the SETTING window, select "10 OPTIONAL."
 - The OPTIONAL window will appear.

2. Select any option from the following options list:
 - 1 FUNC.PROHIBIT.: Function prohibition
 - 2 FUNC.SELECT1: Function selection 1
 - 3 FUNC.SELECT2: Function selection 2
 - 4 PRINT SELECT: Printing selection

The following illustration shows those options included in the optional feature programming group.

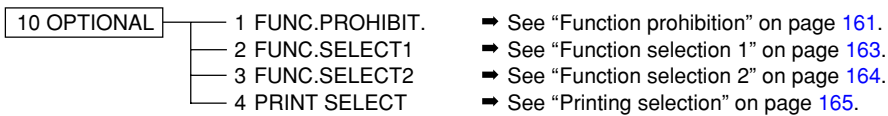

■ Function prohibition

Your POS terminal allows you to select whether to enable or disable various functions.

Program each item as follows:

Procedure

- **OPX/Z REPORT (Use the selective entry)**

DISABLE: Disables the server report printing in the OP X/Z mode.

ENABLE: Enables the server report printing in the OP X/Z mode.

- **PAID OUT (Use the selective entry)**

LIMITED: Allowed only in the MGR mode.

PUBLIC: Allowed in the REG and MGR modes.

- **RFND SALES (Use the selective entry)**

LIMITED: Allowed only in the MGR mode.

PUBLIC: Allowed in the REG and MGR modes.

- **(-) ENTRY (Use the selective entry)**

LIMITED: Allowed only in the MGR mode.

PUBLIC: Allowed in the REG and MGR modes.

- **RF/RETURN (Use the selective entry)**

LIMITED: Allowed only in the MGR mode.

PUBLIC: Allowed in the REG and MGR modes.

- **1st LAST VD (Use the selective entry)**

DISABLE: Disables first-item direct void.

ENABLE: Enables first-item direct void.

- **DIRECT VD (Use the selective entry)**

LIMITED: Allowed only in the MGR mode.

PUBLIC: Allowed in the REG and MGR modes.

- **INDIR. VD (Use the selective entry)**

LIMITED: Allowed only in the MGR mode.

PUBLIC: Allowed in the REG and MGR modes.

- **SBTL VOID (Use the selective entry)**

LIMITED: Allowed only in the MGR mode.

PUBLIC: Allowed in the REG and MGR modes.

- **VOID MODE (Use the selective entry)**

LIMITED: Allowed only in the MGR mode.

PUBLIC: Allowed in the REG and MGR modes.

- **NO SALE (Use the selective entry)**

LIMITED: Allowed only in the MGR mode.

PUBLIC: Allowed in the REG and MGR modes.

- **PAY WHEN ST=0 (Use the selective entry)**

DISABLE: Disables finalization in the REG mode when the subtotal is zero.

ENABLE: Enables finalization in the REG mode when the subtotal is zero.

- **TIP PAID (Use the selective entry)**

LIMITED: Allowed only in the MGR mode.

PUBLIC: Allowed in the REG and MGR modes.

- **TRANS IN/OUT (Use the selective entry)**

LIMITED: Allowed only in the MGR mode.

PUBLIC: Allowed in the REG and MGR modes.

FUNC. PROHIBIT		↓
OPX/Z REPORT	ENABLE	
PAID OUT	PUBLIC	
RFND SALES	PUBLIC	
(-) ENTRY	PUBLIC	
RF/RETURN	PUBLIC	
1st LAST VD	ENABLE	

The screen continues.

■ Function prohibition (continued)

- **P.VD IN GLU (Use the selective entry)**

- DISABLE: Disables the indirect void/refund/return entry with in the GLU re-order.

- ENABLE: Enables the indirect void/refund/return entry with in the GLU re-order.

- **OPEN GLU DISP (Use the selective entry)**

- DISABLE: Does not displays GLU currently opened automatically.

- ENABLE: Displays and recalls the GLU balances currently opened automatically.

- **UPC LEARNING (Use the selective entry)**

- DISABLE: Disables the UPC learning function.

- ENABLE: Enables the UPC learning function.

- **PRICE CHANGE (Use the selective entry)**

- LIMITED: Allowed only in the MGR mode.

- PUBLIC: Allowed in the REG and MGR modes.

- **CUSTOMER OPN (Use the selective entry)**

- LIMITED: Allowed only in the MGR mode.

- PUBLIC: Allowed in the REG and MGR modes.

■ Function selection 1

Your POS terminal enables you to select various functional settings.

Program each item as follows:

- **ITEM VP (Use the selective entry)**
 - DISABLE: Disables item validation printing.
 - ENABLE: Enables item validation printing.
- **RF/RT VP (Use the selective entry)**
 - COMPUL.: Compulsory refund/return validation printing.
 - NON-COMPUL.: Non-compulsory refund/return validation printing.
- **(-) VP (Use the selective entry)**
 - COMPUL.: Compulsory minus entry validation printing.
 - NON-COMPUL.: Non-compulsory minus entry validation printing.
- **CA/CHK V (Use the selective entry)**
 - COMPUL.: Compulsory cashing a check validation printing.
 - NON-COMPUL.: Non-compulsory cashing a check validation printing.
- **RA VP (Use the selective entry)**
 - COMPUL.: Compulsory RA validation printing.
 - NON-COMPUL.: Non-compulsory RA validation printing.
- **PO VP (Use the selective entry)**
 - COMPUL.: Compulsory PO validation printing.
 - NON-COMPUL.: Non-compulsory PO validation printing.
- **TIP VP (Use the selective entry)**
 - COMPUL.: Compulsory tip validation printing.
 - NON-COMPUL.: Non-compulsory tip validation printing.
- **L.SFT TYPE <Level shift type> (Use the selective entry)**
 - MANUAL: Lock shift mode
 - AUTO: Automatic return mode
- **LEVEL SHIFT (Use the selective entry)**
 - LIMITED: Allowed only in the MGR mode.
 - PUBLIC: Allowed in the REG and MGR modes.
- **PR.SFT TYPE <Price shift type> (Use the selective entry)**
 - MANUAL: Lock shift mode
 - AUTO: Automatic return mode
- **PRICE SHIFT (Use the selective entry)**
 - LIMITED: Allowed only in the MGR mode.
 - PUBLIC: Allowed in the REG and MGR modes.
- **RETURN TO L1 <Return to level 1> (Use the selective entry)**

When the PLU level shift system is set to "AUTO," the PLU level can be returned to level 1 by one of the following methods:

 - RECEIPT: Returns the PLU level to level 1 by one receipt.
 - BY ITEM: Returns the PLU level to level 1 by one item.
- **RETURN TO P1 <Return to price 1> (Use the selective entry)**

When the PLU price level shift method is set to "AUTO," the price level can be returned to price 1 by one of the following methods:

 - RECEIPT: Returns the price level to price 1 by one receipt.
 - BY ITEM: Returns the price level to price 1 by one item.

Procedure

FUNC.SELECT1		↓
ITEM VP		ENABLE
RF/RT VP	NON-COMPUL.	
(-) VP	NON-COMPUL.	
CA/CHK V	NON-COMPUL.	
RA VP	NON-COMPUL.	
PO VP	NON-COMPUL.	

The screen continues.

■ Function selection 2

Your POS terminal enables you to select various functional settings.

Program each item as follows:

- **SEAT # (Use the selective entry)**

COMPUL.: Compulsory seat number entry (GLU operations)

INHIBIT: Inhibited seat number entry (GLU operations)

- **COVER CT (Use the selective entry)**

COMPUL.: Compulsory cover count entry (GLU operations)

NON-COMPUL.: Non-compulsory cover count entry (GLU operations)

- **TIP ENTRY (Use the selective entry)**

FIX RATE: Tip entry using a programmed rate

AMOUNT: Manual tip entry

- **SRVR DRW (Use the selective entry)**

COMPUL.: Compulsory server drawer assignment at sign-on

INHIBIT: Inhibited server drawer assignment at sign-on

- **SHIFT KEY ACT (Use the selective entry)**

CAPS: Locks the upper-case letter mode once the shift key is pressed.

SHIFT: Shifts the upper-case letter mode to the lower-case letter mode after a letter is entered.

- **AUTO HOURLY (Use the selective entry)**

DISABLE: Disables automatic hourly report.

ENABLE: Enables automatic hourly report.

If "ENABLE" is selected, a hourly report may be issued at hourly intervals automatically.

- **COND. CANCEL (Use the selective entry)**

Select the active mode for the cancel operation from the following.

LIMITED: Allowed only in the MGR mode.

PUBLIC: Allowed in the REG and MGR modes.

- **ISBN PRICE (Use the selective entry)**

Price entry after ISBN/ISSN code entry INHIBIT/COMPUL.

- **CUSTOMER DATA (Use the selective entry)**

TOTAL: Sales total and charge sales total

DETAIL: Detail data (Sales total, charge sales total, sales date, item's name, amount and quantity)

- **SERVER POPUP (Use the selective entry)**

DISABLE: Disables the display of SERVER POPUP sign on window upon 1st item entry.

ENABLE: Enables the display of SERVER POPUP sign on window upon 1st item entry.

- **T-LOG FULL (Use the selective entry)**

LOCK: Locks entries at a terminal when T-LOG buffer becomes full.

CONTINUE: Not locks entries at a terminal even when T-LOG butter becomes full.

- **CAPTURE FUL (Use the selective entry)**

LOCK: Locks entries at a terminal when CAPTURE job memory becomes full.

CONTINUE: Not locks entries at a terminal even when CAPTURE job memory becomes full.

Procedure

FUNC.SELECT2		↓
SEAT#	INHIBIT	
COVER CT	NON-COMPUL.	
TIP ENTRY	AMOUNT	
SRVR DRW	INHIBIT	
SHIFT KEY ACT	CAPS	
AUTO HOURLY	DISABLE	

The screen continues.

■ Printing selection

You can program various printing functions.

Procedure

PRINT SELECT	↓
PURCHASE NO.	NO
TIME	YES
JOURNAL SEL.	FULL
JOURNAL SIZE	NORMAL
ITEM ON BILL	YES
SHARE%	YES

The screen continues.

Program each item as follows:

- **PURCHASE NO. (Use the selective entry)**
 - YES: Prints the number of purchases.
 - NO: Does not print the number of purchases.
- **TIME (Use the selective entry)**
 - NO: Does not print the time on the receipt and journal.
 - YES: Prints the time on the receipt and journal.
- **JOURNAL SEL. (Use the selective entry)**
 - PARTIAL: Prints the summary information on the journal.
 - FULL: Prints the detailed information on the journal.
- **JOURNAL SIZE (Use the selective entry)**
 - NORMAL: Prints the normal-size letters on the journal.
 - SMALL: Prints the compressed-size letters on the journal.
- **ITEM ON BILL (Use the selective entry)**
 - NO: Does not print items in a GLU/PBLU transaction on the bill printer.
 - YES: Prints items in a GLU/PBLU transaction on the bill printer.
- **SHARE% (Use the selective entry)**
 - NO: Does not print the share percent in the department report.
 - YES: Prints the share percent in the department report.
- **REORDER KP MSG. (Use the selective entry)**
 - YES: Prints the reorder message on a kitchen printer.
 - NO: Does not print the reorder message on a kitchen printer.
- **CUSTOMER REP. (Use the selective entry)**
 - Non-payment customer report format
 - DETAIL: Detail data
 - CHARGE: Charge amount data
- **BIRTHDAY (Use the selective entry)**
 - YES: Prints the entered birthday.
 - NO: Does not print the entered birthday.
- **TX STATUS RJ (Use the selective entry)**
 - Taxable status printing on R/J
 - (YES/NO)
- **TX STATUS BILL (Use the selective entry)**
 - Taxable status printing on Bill (Slip)
 - (YES/NO)
- **TX STATUS KP (Use the selective entry)**
 - Taxable status printing on KP
 - (YES/NO)

Secret Code Programming

Use the following procedure to program a secret code:

Procedure

SETTING	↑↓
07 PERSONNEL	
08 TERMINAL	
09 DATE/TIME	
10 OPTIONAL	
11 SECRET CODE	
12 REPORT	



SECRET CODE
1 Z1
2 PGM2
3 SYS Z1
4 SYS PGM2
5 INITIAL D/L
6 MAINTE. D/L

1. In the SETTING window, select "11 SECRET CODE."
 - The SECRET CODE window will appear.

2. Select any option from the following options list:

1 Z1:	Z1 reports
2 PGM2:	PGM2 operations
3 SYS Z1:	System Z1 reports
4 SYS PGM2:	System PGM2 operations
5 INITIAL D/L:	Initial down-loading
6 MAINTE. D/L:	Maintenance down-loading

The following illustration shows those options included in the secret code programming group.

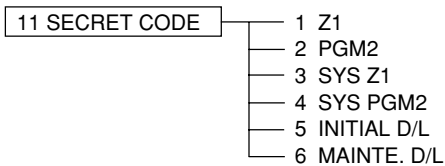

- ➔ See "Z1 reports" on page 167.
- ➔ See "PGM2-mode operations" on page 167.
- ➔ See "System Z1 reports" on page 168.
- ➔ See "System PGM2-mode operations" on page 168.
- ➔ See "Initial down-loading" on page 169.
- ➔ See "Maintenance down-loading" on page 169.

■ Z1 reports

You can assign a secret code to each report.

Secret code: max. 4 digits (0001 to 9999/0000) **(Use the numeric entry)**

NOTE If "0" is entered, the "compulsory secret code entry" will be canceled.

Procedure

Z1	↓
DEPARTMENT	0000
PLU	0000
PLU BY DEPT	0000
DYNAMIC UPC	0000
D-UPC BY DEPT	0000
TRANSACTION	0000

The screen continues.

Program each item as follows:

DEPARTMENT	Department report
PLU	PLU report
PLU BY DEPT	PLU by department report
DYNAMIC UPC	Dynamic UPC report
D-UPC BY DEPT	Dynamic UPC by department report
TRANSACTION	Transaction report
POSITIVE#	Positive number report
ALL SERVER	All server report
IND. SERVER	Individual server report
HOURLY	Hourly report
GLU	GLU report
GLU BY SERVER	GLU by server report
CLOSED GLU	Closed GLU report
CL-GLU BY SERVER	Closed GLU by server report
STACKED REPORT	Stacked report
NON ACCESS UPC	Non-access UPC
D-UPC CLEAR	Dynamic UPC clear report
D-UPC CLR DEPT	Dynamic UPC clear by dept. report
CAT	CAT
RESERVED	Reserved

■ PGM2-mode operations

You can assign a secret code to each programming operation in the PGM2 mode.

Secret code: max. 4 digits (0001 to 9999/0000) **(Use the numeric entry)**

NOTE If "0" is entered, the "compulsory secret code entry" will be canceled.

Procedure

PGM2	↓
ARTICLE	0000
DIRECT KEY	0000
PLU MENU KEY	0000
FUNCTION	0000
MEDIA	0000
TEXT	0000

The screen continues.

Program each item as follows:

ARTICLE	Article programming
DIRECT KEY	Direct key programming
PLU MENU KEY	PLU menu key programming
FUNCTION	Function programming
MEDIA	Media programming
TEXT	Text programming
PERSONNEL	Personnel programming
TERMINAL	Terminal programming
DATE/TIME	Date/time programming
OPTIONAL	Optional programming
SECRET CODE	Secret code programming
REPORT	Report programming
LOGO TEXT	Logo programming
DEVICE CONFIG	Device configuration programming
GLU CODE	GLU code programming
TAX	Tax programming
CUSTOMER	Customer programming
NEGATIVE#	Negative number programming
POSITIVE#	Positive number programming
MACRO KEY	Macro key programming
FUNC. MENU KEY	Function menu key programming
CAPTURE KEY	Capture key programming
CAPTURE JOB#	Capture job programming
TRAINING	Training mode
DATA SEND	Backup data send
DATA RECEIVE	Backup data receive

■ System Z1 reports

You can assign a secret code to each system report.

Secret code: max. 4 digits (0001 to 9999/0000) **(Use the numeric entry)**

NOTE If "0" is entered, the "compulsory secret code entry" will be canceled.

Procedure

SYS Z1	↓
DEPARTMENT	0000
PLU	0000
PLU BY DEPT	0000
DYNAMIC UPC	0000
D-UPC BY DEPT	0000
TRANSACTION	0000

The screen continues.

Program each item as follows:

DEPARTMENT	Department report
PLU	PLU report
PLU BY DEPT	PLU by department report
DYNAMIC UPC	Dynamic UPC report
D-UPC BY DEPT	Dynamic UPC by department report
TRANSACTION	Transaction report
POSITIVE#	Positive number report
ALL SERVER	All server report
IND. SERVER	Individual server report
HOURLY	Hourly report
GLU	GLU report
GLU BY SERVER	GLU by server report
CLOSED GLU	Closed GLU report
CL-GLU BY SERV	Closed GLU by server report
STACKED REPORT	Stacked report

■ System PGM2-mode operations

You can assign a secret code to each system programming operation in the PGM2 mode.

Secret code: max. 4 digits (0001 to 9999/0000) **(Use the numeric entry)**

NOTE If "0" is entered, the "compulsory secret code entry" will be canceled.

Procedure

SYS PGM2	↓
DATA CLEAR	0000
KP SETTING	0000
ONLINE SETTING	0000
CVM SETTING	0000
CAT SETTING	0000
RESERVED	0000

The screen continues.

Program each item as follows:

DATA CLEAR	Data clear operation
KP SETTING	Kitchen printer setting
ONLINE SETTING	Online setting
CVM SETTING	CVM setting
CAT SETTING	CAT setting
RESERVED	Reserved
MWS SETTING	Manager work station setting
INLINE SETTING	Inline setting

■ Initial down-loading (with clearing of memory)

You can assign a secret code to each preset data to be downloaded.

Secret code: max. 4 digits (0001 to 9999/0000) **(Use the numeric entry)**

NOTE If "0" is entered, the "compulsory secret code entry" will be canceled.

Procedure

INITIAL D/L ↓	
DEPT	0000
DIRECT KEY	0000
PLU/UPC	0000
PLU MENU KEY	0000
LINK PLU	0000
CONDIMENT	0000

The screen continues.

Program each item as follows:

DEPT	Department preset
DIRECT KEY	Direct department/PLU preset
PLU/UPC	PLU/UPC preset
PLU MENU KEY	PLU menu key preset
LINK PLU	Link PLU preset
CONDIMENT	Condiment PLU preset
MIX&MATCH	Mix & Match preset
COMBO MEAL	Combo meal preset
UPC NON-PLU	UPC Non-PLU code format
TRANSACTION	Transaction preset
SERV. SIGN OFF	All server sign off
OPTION	Other preset
DATE/TIME	Date/time preset
LOGO	Logo text preset
DEF. MENU LEVEL	Default menu level
TAX	Tax preset
NEGATIVE#	Negative number preset
POSITIVE#	Positive number preset
MACRO KEY	Macro key preset
FUNC. MENU KEY	Function menu key preset
CAPTURE KEY	Capture key preset
CAPTURE JOB#	Capture job preset
ONLINE PRESET	Online preset
INLINE PRESET	Inline preset
KP PRESET	Kitchen printer preset
DEVICE CONFIG	Device configuration preset
ALL PGM	All PGM preset

■ Maintenance down-loading (without clearing of memory)

You can assign a secret code to each preset data to be downloaded.

Secret code: max. 4 digits (0001 to 9999/0000) **(Use the numeric entry)**

NOTE If "0" is entered, the "compulsory secret code entry" will be canceled.

Procedure

MAINT. D/L ↓	
DEPT	0000
DEPT PRICE	0000
DEPT CVM DATA	0000
PLU/UPC	0000
PLU PRICE	0000
PLU CVM DATA	0000

The screen continues.

Program each item as follows:

DEPT	Department preset
DEPT PRICE	Department price preset
DEPT CVM DATA	Dept. CVM data
PLU/UPC	PLU/UPC preset
PLU PRICE	PLU price preset
PLU CVM DATA	PLU CVM data
LINK PLU	Link PLU preset
CONDIMENT	Condiment PLU preset
MIX&MATCH	Mix & Match preset
COMBO MEAL	Combo meal preset
COMBO CVM DATA	Combo CVM data
TRANSACTION	Transaction preset
POSITIVE#	Positive number preset

Report Programming

Use the following procedure to select any option included in the report group:

Procedure

SETTING	↑↓
07 PERSONNEL	
08 TERMINAL	
09 DATE/TIME	
10 OPTIONAL	
11 SECRET CODE	
12 REPORT	



REPORT
1 0 SKIP
2 HOURLY RPT
3 STACKED RPT

1. In the SETTING window, select "12 REPORT."
 - The REPORT window will appear.

2. Select any option from the following list:

- | | |
|----------------|----------------|
| 1 0 SKIP: | Zero skip |
| 2 HOURLY RPT: | Hourly report |
| 3 STACKED RPT: | Stacked report |

The following illustration shows those options included in the report programming group.

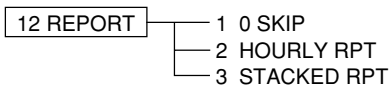

- ➔ See "Zero skip" on page [171](#).
- ➔ See "Hourly report" on page [171](#).
- ➔ See "Stacked report" on page [172](#).

■ Zero skip

You can program whether or not to skip “0” sales totalizer in each report.

Procedure

0 SKIP	
SERVER	SKIP
TRANSACTION	SKIP
DEPARTMENT	SKIP
PLU/UPC	SKIP
HOURLY	SKIP
DAILY NET	SKIP

Program each item as follows:

- **SERVER (Use the selective entry)**

NOT SKIP: Does not skip those data that are “0” sales in the server report.

SKIP: Skips those data that are “0” sales in the server report.

- **TRANSACTION (Use the selective entry)**

NOT SKIP: Does not skip those data that are “0” sales in the transaction report.

SKIP: Skips those data that are “0” sales in the transaction report.

- **DEPARTMENT (Use the selective entry)**

NOT SKIP: Does not skip those data that are “0” sales in the department report.

SKIP: Skips those data that are “0” sales in the department report.

- **PLU/UPC (Use the selective entry)**

NOT SKIP: Does not skip those data that are “0” sales in the PLU/UPC report.

SKIP: Skips those data that are “0” sales in the PLU/UPC report.

- **HOURLY (Use the selective entry)**

NOT SKIP: Does not skip those data that are “0” sales in the hourly report.

SKIP: Skips those data that are “0” sales in the hourly report.

- **DAILY NET (Use the selective entry)**

NOT SKIP: Does not skip those data that are “0” sales in the daily net report.

SKIP: Skips those data that are “0” sales in the daily net report.

■ Hourly report

You can program the memory type and the starting time for the hourly report.

Procedure

HOURLY RPT	
MEMORY TYPE	30MIN
STARTING TIME	00

Program each item as follows:

- **MEMORY TYPE (Use the selective entry)**

15MIN: Selects the 15-minute type.

30MIN: Selects the 30-minute type.

60MIN: Selects the 60-minute type.

- **STARTING TIME (Use the numeric entry)**

Starting time entry (max. 2 digits: 0 to 23)

■ Stacked report

Your POS terminal is equipped with the stacked report printing function that enables multiple X/Z reports to be printed in sequence with a single request.

Procedure

Select a stacked report no. from the stacked reports list.

```
REPORT 1 ↓
01
02
03
04
05
06
```

The screen continues.

```
01 ↓
01 DEPARTMENT
02 DEPT . IND . GROUP
03 DEPT . GR . TOTAL
04 M-DOWN DEPT .
05 PLU/UPC
06 PLU BY DEPT
```

The screen continues.

You can select a maximum of twenty reports from the stacked reports list. Some reports can be set their parameters such as "START CODE" and "END CODE."

- **01 DEPARTMENT (Use the numeric entry)**
Full department report
Parameter: Start department code/end department code (1 thru 50)
- **02 DEPT.IND.GROUP (Use the numeric entry)**
Individual group report on departments
Parameter: Department group no. (1 thru 9)
- **03 DEPT.GR. TOTAL**
Full group total report on departments
- **04 M-DOWN DEPT. (Use the numeric entry)**
Markdown for department report
Parameter: Start department code/end department code (1 thru 50)
- **05 PLU/UPC (Use the numeric entry)**
PLU report by designated range
Parameter: Start PLU code/end PLU code (1 thru 999999)
- **06 PLU BY DEPT (Use the numeric entry)**
PLU report by associated departments
Parameter: Department code (1 thru 50)
- **07 PLU IND. GROUP (Use the numeric entry)**
PLU report by individual group
Parameter: PLU group no. (00 thru 99)
- **08 PLU GR. TOTAL**
Full group total report on PLUs
- **09 PLU STOCK (Use the numeric entry)**
PLU stock report
Parameter: Start PLU code/end PLU code (1 thru 99999)
- **10 PLU MIN. STOCK (Use the numeric entry)**
PLU minimum stock report
Parameter: Start PLU code/end PLU code (1 thru 99999)
- **11 PLU ZERO SALES (Use the selective/numeric entry)**
PLU zero sales report
Parameter: 1 ALL/2 BY DEPT.
When "2 BY DEPT." is selected, enter a department code (1 thru 50).

■ Stacked report (continued)

- **12 PLU CATEGORY (Use the numeric entry)**

PLU price category report

Parameter: Start unit price/end unit price

- **13 DYNAMIC UPC**

Dynamic UPC report

- **14 TRANSACTION**

Transaction report

- **15 CID**

Cash in drawer report

- **16 TAX**

Tax report

- **17 ALL SERVER**

Full server report

- **18 IND. SERVER (Use the numeric entry)**

Individual server report

Parameter: Server code (1 thru 9999)

- **19 HOURLY (Use the numeric entry)**

Hourly report

Parameter: Start time/end time (0 thru 2345)

NOTE

To take the hourly Z report, you have to specify the full-range hourly report.

- **20 POSITIVE CHECK**

Positive check report

- **21 KEY CAPTURE**

Key capture report

- **22 GLU (Use the numeric entry)**

GLU/PBLU report

Parameter: Start GLU code/end GLU code (1 thru 99999999)

- **23 GLU BY SERVER (Use the numeric entry)**

GLU/PBLU report by server

Parameter: Server code (1 thru 9999/Up to 255 servers can be assigned.)

- **24 CLOSED GLU (Use the numeric entry)**

Closed GLU/PBLU report

Parameter: Start GLU code/end GLU code (1 thru 99999999)

- **25 CL-GLU BY SERV (Use the numeric entry)**

Closed GLU/PBLU report by server

Parameter: Server code (1 thru 9999/Up to 255 servers can be assigned.)

■ Stacked report (continued)

- **26 CUSTOM SALES1 (Use the numeric entry)**
Customer report 1
Parameter: Start customer code/end customer code
- **27 CUSTOM SALES2 (Use the numeric entry)**
Customer report 2
Parameter: Start customer code/end customer code
- **28 CHARGE ACCOUNT**
Charge account (customer no payment) report
- **29 NO ACCES. CUST.**
No-access customer report
- **30 DAILY NET**
Daily net report

Logo Text Programming

Use the following procedure to select any option included in the logo text group.

Procedure

SETTING ↑↓
13 LOGO TEXT
14 DEVICE CONFIG
15 GLU CODE
16 CUSTOMER
17 NEGATIVE#
18 POSITIVE#



LOGO TEXT
1 RECEIPT LOGO
2 UP TEXT
3 BILL LOGO

1. In the SETTING window, select "13 LOGO TEXT."
 - The LOGO TEXT window will appear.

2. Select any option from the following options list:

- | | |
|-----------------|--------------------------|
| 1 RECEIPT LOGO: | Receipt logo |
| 2 VP TEXT: | Validation printing text |
| 3 BILL LOGO: | Bill logo |

The following illustration shows those options included in the logo text programming group.



■ Receipt logo

Your POS terminal can print programmed messages for customers on every receipt.

Procedure

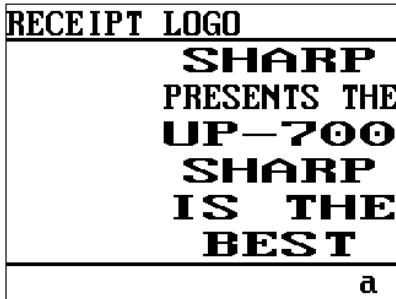

Program the item as follows:

- **RECEIPT LOGO (Use the character entry)**

Logo text for the receipt (max. 30 characters x 6 lines)

NOTE

The programmable number of lines for a message varies according to the message type: the "3-line header message" type, "3-line footer message" type, "6-line header message" type and "Stamp only" type. Please contact your authorized SHARP dealer.

■ Validation printing text

Your POS terminal can print programmed validation messages.

Procedure

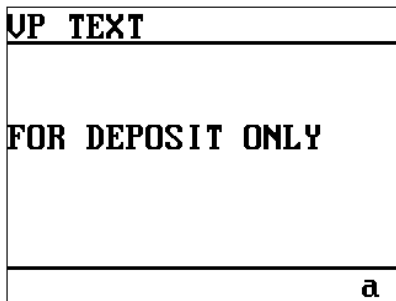

Program the item as follows:

- **VP TEXT (Use the character entry)**

Text for the validation slip (max. 30 characters x 3 lines)

■ Bill logo

Your POS terminal can print programmed messages for customers on the bill. Shown below is an example of selecting “1 HEADER”.

Procedure

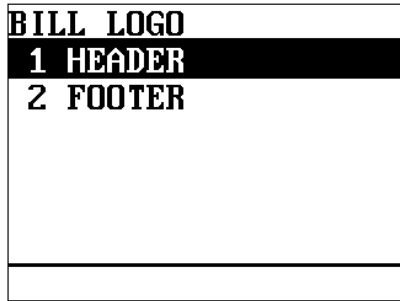

A screenshot of a POS terminal menu. At the top, it says "BILL LOGO". Below that, "1 HEADER" is highlighted with a black background. Underneath, "2 FOOTER" is visible. The rest of the screen is blank.

↓ It is assumed that you have selected “1 HEADER.”

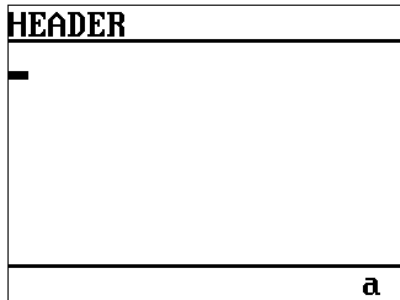

A screenshot of a POS terminal showing the "HEADER" screen. The word "HEADER" is at the top. Below it, there is a small cursor on the first line. At the bottom right, there is a small "a".

When “1 HEADER” is selected:

- **HEADER (Use the character entry)**
Header text for the bill (max. 40 characters x 3 lines)

When “2 FOOTER” is selected:

- **FOOTER (Use the character entry)**
Footer text for the bill (max. 30 characters x 6 lines)

NOTE

Header/Footer text for bill printer programming.

Device Configuration Programming

Use the following procedure to select a device configuration programming:

Procedure

```

SETTING      ↑↓
13 LOGO TEXT
14 DEVICE CONFIG
15 GLU CODE
16 CUSTOMER
17 NEGATIVE#
18 POSITIVE#
    
```



```

DEVICE CONFIG ↓
01 R/J PRINTER
02 BILL(SLIP)
03 REPORT PRINTER
04 VALIDATION(VP)
05 KP#1
06 KP#2
    
```

The screen continues.

1. In the SETTING window, select “14 DEVICE CONFIG.”
 - The DEVICE CONFIG window will appear.

2. Select any option from the following options list:

- | | |
|---------------------|--|
| 01 R/J PRINTER: | Receipt/Journal Printer (Built-in printer) |
| 02 BILL (SLIP): | Bill (Slip) printer |
| 03 REPORT PRINTER: | Report printer |
| 04 VALIDATION (VP): | Validation printer |
| 05 KP#1: | Remote printer #1 |
| 06 KP#2: | Remote printer #2 |
| 07 KP#3: | Remote printer #3 |
| 08 KP#4: | Remote printer #4 |
| 09 KP#5: | Remote printer #5 |
| 10 KP#6: | Remote printer #6 |
| 11 KP#7: | Remote printer #7 |
| 12 KP#8: | Remote printer #8 |
| 13 KP#9: | Remote printer #9 |
| 14 BCR(SCANNER): | Scanner |

The following illustration shows those options included in the device configuration programming group.

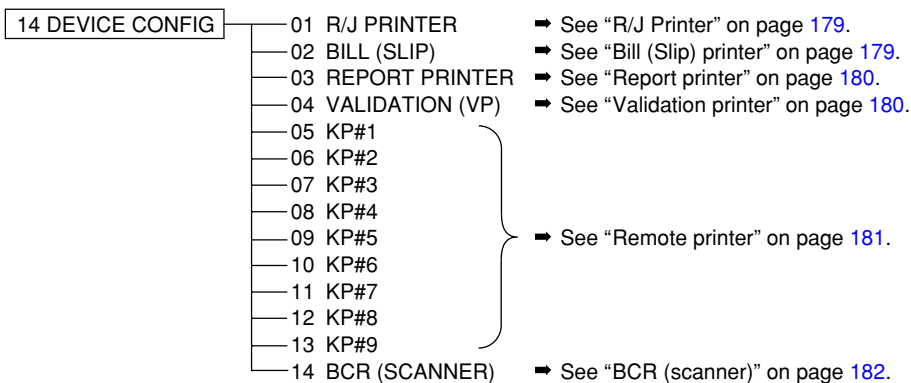

■ R/J printer (Built-in printer)

Procedure

R/J PRINTER	
TRAY ST FEED#	0

Program each item as follows:

- **TRAY ST FEED# (Use the numeric entry)**
Tray subtotal feed line (0 to 9)

■ Bill (slip) printer

Procedure

BILL(SLIP)	
PRINTER	TM-295
AUTO CUTTER	NO
INITIAL FEED#	00
SLIP MAX LINE	99

Program each item as follows:

- **PRINTER (Use the selective entry)**
Select the printer to be used.
EPSON TM-295 EPSON TM-T88/85
EPSON TM-T80 EPSON TM-U200
EPSON TM-T88(2) EPSON TM-300
- **AUTO CUTTER (Use the selective entry)**
Auto cutter function
YES: Enables auto cutter function.
NO: Disables auto cutter function.
(This item is invalid for TM-295.)
- **INITIAL FEED# (Use the numeric entry)**
Initial line feed for a slip (0 to 64 lines): only for TM-295
- **SLIP MAX LINE (Use the numeric entry)**
Maximum number of lines printable on a slip (0 to 99): only for TM-295

■ Report printer

Procedure

REPORT PRINTER	
PRINTER	BUILT-IN
AUTO CUTTER	NO
LOGO TEXT	PRINT

Program each item as follows:

- **PRINTER (Use the selective entry)**

Select the printer to be used.

EPSON TM-T80

EPSON TM-U200

EPSON TM-T88/85

EPSON TM-300

EPSON TM-T88(2)

BUILT-IN (built-in printer)

- **AUTO CUTTER (Use the selective entry)**

Auto cutter function

YES: Enables auto cutter function.

NO: Disables auto cutter function.

- **LOGO TEXT (Use the selective entry)**

Select the logo text printing status.

NOT PRINT: Logo text is not printed.

PRINT: Logo text is printed.

■ Validation printer

Procedure

VALIDATION(VP)	
PRINTER	BUILT-IN
VP TIMES	1

Program each item as follows:

- **PRINTER (Use the selective entry)**

Select the printer to be used.

BUILT-IN (built-in printer)

EPSON TM-295

- **VP TIMES (Use the numeric entry)**

Number of times of validation printing (0 thru 9)

■ Remote printer (KP#1 thru KP#9)

Procedure

KP#1	
PRINTER	TM-T88/85
AUTO CUTTER	NO
LOGO TEXT	NOT PRINT

Program each item as follows:

- **PRINTER (Use the selective entry)**

Select the printer to be used.

EPSON TM-U200	EPSON TM-300
EPSON TM-T88/85	EPSON TM-T80
EPSON TM-T88(2)	BUILT-IN (built-in printer)

- **AUTO CUTTER (Use the selective entry)**

Auto cutter function

YES: Enables auto cutter function.

NO: Disables auto cutter function.

- **LOGO TEXT (Use the selective entry)**

Select the logo text printing status.

NOT PRINT: Logo text is not printed.

PRINT: Logo text is printed.

■ BCR (SCANNER)

Procedure

BCR(SCANNER)	
BAUD RATE	4800bps
DATA BITS	7 Bits
PARITY	ODD
STOP BIT	1 Bit

Program each item as follows:

- **BAUD RATE (Use the selective entry)**
Transmission speed (baud rate)
19200 bps/9600 bps/4800 bps
- **DATA BITS (Use the selective entry)**
Data bit: 7 bits/8 bits
- **PARITY (Use the selective entry)**
Parity bit: NON/ODD/EVEN
- **STOP BIT (Use the selective entry)**
Stop bit: 1 bit/2 bits

GLU Code Programming

Use the following procedure to select an option included in the GLU code group:

Procedure

SETTING	↑↓
13 LOGO TEXT	
14 DEVICE CONFIG	
15 GLU CODE	
16 CUSTOMER	
17 NEGATIVE#	
18 POSITIVE#	



GLU CODE
1 GLU



GLU	
START CODE	0001
END CODE	9999

1. In the SETTING window, select "15 GLU CODE."
 - The GLU CODE window will appear.

2. Select any item from the following options list:
 - 1 GLU: GLU/PBLU code

You can program the range of available guest check codes.

Program each item as follows:

- **START CODE (Use the numeric entry)**
Start GLU code (max. 4 digits: 1 to 9999)
- **END CODE (Use the numeric entry)**
End GLU code (max. 4 digits: 1 to 9999)

Customer Programming

Use the following procedure to select any option included in the customer programming group:

Procedure

SETTING	↑↓
13 LOGO TEXT	
14 DEVICE CONFIG	
15 GLU CODE	
16 CUSTOMER	
17 NEGATIVE#	
18 POSITIVE#	



CUSTOMER
1 CUSTOMER
2 CUSTOMER PROG.

1. In the SETTING window, select "16 CUSTOMER".

2. Select an option from the following options list:

- 1 CUSTOMER: Customer code
- 2 CUSTOMER PROG.: Customer programming

The following illustration shows those options included in the customer programming group.

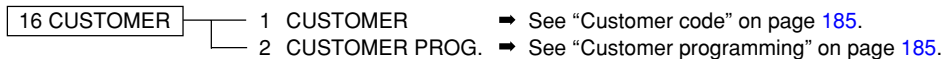

■ Customer code

Procedure

Select or enter the pertinent customer code.

00000000000001
 NAM XXXXXXXXXXXXXXXXXXXX

 _____ a

Program each item as follows:

- **NAME (Use the character entry)**
Enter a customer's name (max. 16 characters)
- **ADDRESS (Use the character entry)**
On the second line, enter the customer's address (max. 40 characters)

■ Customer programming

Procedure

CUSTOMER PROG.
 PERIOD:MONTH 99

Program each item as follows:

- **PERIOD:MONTH (Use the numeric entry)**
Preset a period to delete customer detail data.
Enter the period in a unit of month. (01 to 99)
If you enter "00", the customer detail data will not be deleted.

NOTE If the following condition is satisfied, its code is deleted using the deleting operation.

Date of the deleting (Year, Month) \geq Date of the last access (Year, Month) + programmed period + 1
 [Ex.] Date of the deleting = 8/(1 to 31)/2002, Period = 12 months:

Customer	Date of the last access	
Customer A	(6/(1 to 30)/2001)	→ Deleted
Customer B	(7/(1 to 31)/2001)	→ Deleted
Customer C	(8/(1 to 31)/2001)	→ Kept intact

Negative Code File Programming

Use the following procedure to select the menu option "17 NEGATIVE#" :

■ Negative code/Override status

You can program the negative code and its override status.

Procedure

SETTING	↑↓
13 LOGO TEXT	
14 DEVICE CONFIG	
15 GLU CODE	
16 CUSTOMER	
17 NEGATIVE#	
18 POSITIVE#	

NEGATIVE#
---NOTHING---

Selected negative code →

#000000000000000001
OVERRIDE INHIBIT

Program the item as follows:

- **NEGATIVE# (Use the numeric entry)**
Negative code (max. 16 digits)
- **OVERRIDE (Use the selective entry)**
Negative code checking can be overridden in compliance with programmed override status.
(Override/access operation: →)
(Not to override: →)

REG&MGR: Allowed in REG and MGR modes.

The message "ACCESS" is displayed.

MGR ONLY: Allowed only in MGR mode.

The message "CALL MGR" is displayed.

INHIBIT: The override operation is inhibited.

The message "NOT ACCEPT" is displayed.

NOTE

- When you create a new code, enter the code, then press the key.
- When you delete a negative code, enter the code or move the cursor to pertinent negative code, then press the key.

Positive Code File Programming

Use the following procedure to select the menu option "18 POSITIVE#" :

■ Positive code

You can create/delete the positive code.

Procedure

SETTING ↑↓
13 LOGO TEXT
14 DEVICE CONFIG
15 GLU CODE
16 CUSTOMER
17 NEGATIVE#
18 POSITIVE#



POSITIVE#
---NOTHING---



Selected positive code →



POSITIVE#
#000000000000000001

Program the item as follows:

- **POSITIVE# (Use the numeric entry)**
Positive code (max. 16 digits)

NOTE

- When you create a new code, enter the code, then press the key.
- When you delete a positive code, enter the code or move the cursor to pertinent positive code, then press the key.

Macro Key Programming

Use the following procedure to select the menu option "19 MACRO KEY" :

■ Mode position/Auto key no.

The purpose of the Macro Key Function is to run a series of instructions with a single key stroke. You can program up to 15 max. mode position/auto key no. for each macro key.

Procedure

SETTING	↑↓
19 MACRO KEY	
20 FUNC.MENU KEY	
21 CAPTURE KEY	
22 CAPTURE JOB#	
23 TAX	
24 TRAINING	



MACRO KEY	
1 MACRO#1	
2 MACRO#2	
3 MACRO#3	
4 MACRO#4	



Select a pertinent macro key.



MACRO#1	↓
MODE#1	INHIBIT
KEY#1	INHIBIT
MODE#2	INHIBIT
KEY#2	INHIBIT
MODE#3	INHIBIT
KEY#3	INHIBIT

Program the item as follows:

- **MACRO#1 thru MACRO#4 (Use the selective entry)**

Select the pertinent macro key from the list.

- **MODE#1 thru MODE#15 (Use the selective entry)**

INHIBIT: AUTO key is inhibited.

PGM2: PGM2 mode

PGM1: PGM1 mode

OPXZ: OP X/Z mode

REG: REG mode

MGR: MGR mode

X1Z1: X1/Z1 mode

X2Z2: X2/Z2 mode

- **KEY#1 thru KEY#15 (Use the selective entry)**

INHIBIT: AUTO key is inhibited.

AUTO1 thru AUTO25: AUTO key no.

Function Menu Key Programming

Use the following procedure to select Function menu key programming:

■ Function menu key

You can program a max. of 15 functions for each function menu key.

Procedure

SETTING	↑↓
19 MACRO KEY	
20 FUNC.MENU KEY	
21 CAPTURE KEY	
22 CAPTURE JOB#	

FUNC.MENU KEY	↓
01 INHIBIT	
02 INHIBIT	
03 INHIBIT	
04 INHIBIT	
05 INHIBIT	
06 INHIBIT	

Select menu no. →

01	↓
001 INHIBIT	
002 %1	
003 %2	
004 %3	
005 %4	
006 %5	

Select function →

FUNC.MENU KEY	↓
01 %1	
02 INHIBIT	
03 INHIBIT	

Use the following procedure to program the function menu key.

1. In the SETTING window, select "20 FUNC.MENU KEY".
 - The FUNC.MENU KEY window will appear.

2. Select menu number (01 thru 15).

NOTE

- If the key is pressed on the menu number selection, the function will be canceled.

3. Select function from the following list.

Function no.	Function
001	INHIBIT
002	%1
003	%2
004	%3
005	%4
006	%5
}	}
135	CAP.10

Capture Key Programming

Use the following procedure to select the menu option "21 CAPTURE KEY" :

■ Capture key data

You can program max. 10 data capture key entries for the capture data function.

Procedure

SETTING	↑↓
19 MACRO KEY	
20 FUNC.MENU KEY	
21 CAPTURE KEY	
22 CAPTURE JOB#	
23 TAX	
24 TRAINING	

CAPTURE KEY	↓
01 CAPTURE01	
02 CAPTURE02	
03 CAPTURE03	
04 CAPTURE04	
05 CAPTURE05	
06 CAPTURE06	

The screen continues.

Select a pertinent data capture key. →

CAP. 1	
TEXT	CAPTURE01
TEXT PRINT	NO
ENTRY COMPUL	NO
LINK JOB#	00

a

Program the item as follows:

- **CAPTURE01 thru 10 (Use the selective entry)**
Select the desired data capture key from the list.
- **TEXT (Use the character entry)**
Description for the data capture key. Up to 12 characters can be entered.
- **TEXT PRINT (Use the selective entry)**
YES: Print the data capture key TEXT on R/J or bill.
NO: Does not print the data capture key TEXT.
- **ENTRY COMPUL (Use the selective entry)**
Enforcing the data capture key.
BEGIN: Enforced at the beginning of transaction.
END: Enforced at the end of the transaction.
NO: Not enforced-assigned key data function no.
- **LINK JOB# (Use the numeric entry)**
Capture job number (1 to 99)

Key Data Entry Job Table Programming

Use the following procedure to select the menu option "22 CAPTURE JOB#":

■ Capture job number

You can program a max. of 99 capture job numbers.

Procedure

SETTING	↑↓
19 MACRO KEY	
20 FUNC.MENU KEY	
21 CAPTURE KEY	
22 CAPTURE JOB#	
23 TAX	
24 TRAINING	



CAPTURE JOB#
--- NOTHING ---



Select a pertinent job number. →



01	↓
MESSAGE	
ENTRY#1	INHIBIT
MAX.LENGTH#1	13
MIN.LENGTH#1	00
TEXT PRINT#1	NO
MESSAGE	
	a

The screen continues.

Program the item as follows:

- **CAPTURE JOB# (Use the selective entry)**
Select the pertinent capture Job number. (1 to 99)
- **MESSAGE (Use the character entry)**
Description for the job (display message). Up to 12 characters can be entered.
(for job#1 thru 4)
- **ENTRY#1 thru 4 (Use the selective entry)**
Data entry type
 NUMERIC: Numeric data type
 CHARACTER: Character data type
 INHIBIT: Data entry is inhibited.
- **MAX. LENGTH#1 thru 4 (Use the numeric entry)**
Max. length of data entry (0 to 13)
"0" means the ENTER key entry only.
- **MIN. LENGTH#1 thru 4 (Use the numeric entry)**
Min. length of data entry (0 to 13)
- **TEXT PRINT#1 thru 4 (Use the selective entry)**
 YES: Prints the entry data on R/J or Bill printer.
 NO: Does not print the entry data.

NOTE

- If the key is pressed on the job number selection menu, the selected job table will be deleted.

Tax Programming

Use the following procedure to select any option included in the tax group:

Procedure

SETTING	↑↓
19 MACRO KEY	
20 FUNC.MENU KEY	
21 CAPTURE KEY	
22 CAPTURE JOB#	
23 TAX	
24 TRAINING	



TAX
1 TAX1
2 TAX2
3 TAX3
4 TAX4

1. In the SETTING window, select "23 TAX."
 - The TAX window will appear.

2. Select any option from the following options list:

1 TAX1:	Tax1
2 TAX2:	Tax2
3 TAX3:	Tax3
4 TAX4:	Tax4
5 DOUGHNUT EXPT:	Doughnut exemption (for the Canadian tax system)

NOTE

- The option "5 DOUGHNUT EXPT" appears only when the Canadian tax system is selected.
- If the **[DEL]** key is pressed on the tax number selection menu, the tax table or the tax in the cursor position will be deleted.

The following illustration shows those options included in the tax programming group.

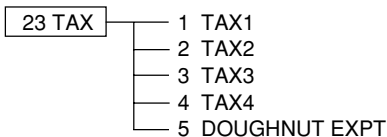

- ➔ See "Table tax" on page 193 or "Rate (%) tax" on page 195.
- ➔ See "Table tax" on page 193 or "Rate (%) tax" on page 195.
- ➔ See "Table tax" on page 193 or "Rate (%) tax" on page 195.
- ➔ See "Table tax" on page 193 or "Rate (%) tax" on page 195.
- ➔ See "Doughnut tax exempt" on page 195.

■ Table tax

Your POS terminal has an automatic tax calculation feature which allows you to program four tax tables. Automatic tax calculations require you to program, in addition to the tax table, the tax status of each pertinent department, PLU, and function key.

Sample tax table

New Jersey tax table: 6%

Tax	Range of sales amount		A: Difference between a minimum breakpoint and the next one (¢)	
	Minimum breakpoint	Maximum breakpoint		
.00	.01	to	.10	
.01-T	.11-Q	to	.22	B: Non-cyclic
.02	.23	to	.38	
.03	.39	to	.56	
.04	.57	to	.72	
.05	.73	to	.88	
.06	.89	to	1.10	
.07	1.11-M1	to	1.22	C: Cyclic 1
.08	1.23	to	1.38	
.09	1.39	to	1.56	
.10	1.57	to	1.72	
.11	1.73	to	1.88	
.12	1.89	to	2.10	
.13	2.11-M2	to	2.22	D: Cyclic 2

To program a tax table, first make a table like the right table shown above.

From the tax table, calculate the differences between a minimum breakpoint and the next one (A). Then, from the differences, find irregular cycles (B) and regular cycles (C and D). These cycles will show you the following items necessary to program the tax table:

T: Tax amount collected on the minimum taxable amount (Q)

Q: Minimum taxable amount

M1: Maximum value of the minimum breakpoint on a regular cycle (C).
We call this point "MAX point."

M2: Maximum value of the minimum breakpoint on a regular cycle (D).
We call this point "MAX point."

M: Range of the minimum breakpoint on a regular cycle: difference between Q and M1 or between M1 and M2

■ Table tax (continued)

Procedure

Select a pertinent tax no. from the taxes list.

TAX1
1 TABLE TAX
2 %TAX

TABLE TAX
1 INTVL LOW 0.99
2 INTVL OVR 1.00

TABLE TAX	↓
TAX RATE	0.0000%
CYCLE	0.00
INITIAL TAX	0.00
LOWER LIMIT	0.00
BREAK POINT1	0.00
BREAK POINT2	0.00

The screen continues.

Program each item as follows:

- **TAX RATE (Use the numeric entry)**
Tax rate for the tax table (max. 7 digits: 0.0000 to 999.9999)
- **CYCLE (Use the numeric entry)**
Range of the minimum breakpoint on a regular cycle for the tax table (max. 4 digits: 0.01 to 99.99)
See the description "M" shown on the previous page.
- **INITIAL TAX (Use the numeric entry)**
Initial tax amount for the tax table (max. 3 digits: 0.01 to 9.99)
See the description "T" shown on the previous page.
- **LOWER LIMIT (Use the numeric entry)**
Minimum taxable amount for the tax table (max. 5 digits: 0.01 to 999.99)
See the description "Q" shown on the previous page.
- **BREAK POINT1 thru 72 (Use the numeric entry)**
Breakpoints programmable for the tax table (max. 5 digits: 0.01 to 999.99)
Seventy-two breakpoints can be programmed for each tax table. When the interval between breakpoints is one dollar or more and less than one-hundred dollar, 36 breakpoints are programmed for each tax table.

■ Rate (%) tax

You can program a tax rate for each tax rate number.

Procedure

Select a pertinent tax no. from the taxes list.

TAX1
1 TABLE TAX
2 %TAX

%TAX
TAX RATE 0.0000%
LOWER LIMIT 0.00

Program each item as follows:

- **TAX RATE (Use the numeric entry)**
Tax rate (max. 7 digits: 0.0000 to 999.9999%)
- **LOWER LIMIT (Use the numeric entry)**
Lowest taxable amount (max. 5 digits: 0.01 to 999.99)

■ Doughnut tax exempt (for the Canadian tax system)

Procedure

DOUGHNUT EXPT
QUANTITY 0

Program the item as follows:

- **QUANTITY (Use the numeric entry)**
Quantity for the doughnut tax exempt (for Canadian tax)
(max. 2 digits: 1 to 99/0)

NOTE

This option is available only when the Canadian tax system is selected.

TRAINING Mode Selection

Use the following procedure to select the training mode:

■ TRAINING mode

You will use the TRAINING mode if you need to train someone in machine operations without any change in POS terminal's memory. Reports are not available. When the training is completed, exit this mode and put your POS terminal back into the normal mode of operation.

Procedure

SETTING	↑↓
19 MACRO KEY	
20 FUNC.MENU KEY	
21 CAPTURE KEY	
22 CAPTURE JOB#	
23 TAX	
24 TRAINING	



TRAINING	
TRAINING MODE	NO

Program the item as follows:

• TRAINING MODE (Use the selective entry)

YES: Allows entering the training mode.

NO: Disallows entering the training mode.

NOTE

- All operations in the training mode are the same as the REG-mode operations.
- In the training mode, the consecutive number is incremented.
- The cash drawer does not open in the training mode.
Items normally sent to the remote printers are not sent.

Backup Data Send Programming

Use the following procedure to select the menu option "25 BACKUP SEND":

NOTE

For more information, please consult your authorized SHARP dealer.

■ Backup data send

Your POS terminal can send data to another device for the purpose of backing its program up.

Procedure

SETTING	↑
21 CAPTURE KEY	
22 CAPTURE JOB#	
23 TAX	
24 TRAINING	
25 BACKUP SEND	
26 BACKUP RECEIVE	



BACKUP SEND	
SEND DATA	ALL RAM
SPEED	PROGRAMMED

Program each item as follows:

• SEND DATA (Use the selective entry)

Select one of the following options (data sources):

- ALL RAM
- SSP

• SPEED (Use the selective entry)

Select one of the following options (data transmission speeds):

PROGRAMMED: Sends data at a programmed speed.

115200bps: Sends data at 115200 bps.

57600bps: Sends data at 57600 bps.

38400bps: Sends data at 38400 bps.

19200bps: Sends data at 19200 bps.

9600bps: Sends data at 9600 bps.

4800bps: Sends data at 4800 bps.

2400bps: Sends data at 2400 bps.

Backup Data Receive Programming

Use the following procedure to select the menu option "26 BACKUP RECEIVE":

NOTE

For more information, please consult your authorized SHARP dealer.

■ Backup data receive

Your POS terminal can receive data from another device which has previously received the data.

Procedure

SETTING	↑
21 CAPTURE KEY	
22 CAPTURE JOB#	
23 TAX	
24 TRAINING	
25 BACKUP SEND	
26 BACKUP RECEIVE	



BACKUP RECEIVE	
SPEED	PROGRAMMED

Program the item as follows:

• SPEED (Use the selective entry)

Select one of the following options (data transmission speeds):

PROGRAMMED: Receives data at a programmed speed.

115200bps: Receives data at 115200 bps.

57600bps: Receives data at 57600 bps.

38400bps: Receives data at 38400 bps.

19200bps: Receives data at 19200 bps.

9600bps: Receives data at 9600 bps.

4800bps: Receives data at 4800 bps.

2400bps: Receives data at 2400 bps.

CAUTION: The receiving unit must have equal or greater memories than the terminal sending the program.

PLU Updating (in the PGM1 Mode)

The PLU UPDATE option is chiefly used for daily changes of the PLU's unit price or name by a supervisor or manager.

Procedure

PGM1
1 READING
2 SETTING
3 PLU UPDATE



PLU/UPC	↓
00001	PL00001
00002	PL00002
00003	PL00003



00001
PRICE 1 0.00
1# PL00001
KP1 PL00001

To program a unit price or name for the PLU as follows:

1. In the PGM1 window, press the  key or select the option "3 PLU UPDATE".
 - The PLU list will appear.

2. Select any PLU code from the list.

3. Program a unit price or name for the corresponding price level.

- ***PRICE1 thru 6 (Use the numeric entry)**
Unit price of each price level (max. 6 digits)
- ***1# thru 6 (Use the character entry)**
Name of each price level. Up to 8 or 16 characters can be entered.
- ***KP1 thru 6 (Use the character entry)**
Description of text for kitchen printer for each price level. Up to 12 characters can be entered.

NOTE

* On the sample screen, the price level 1 setting is only shown. Depending on the default settings, you may see the price level 1 through 6 settings on the screen. Please consult your authorized SHARP dealer for more details.

Automatic Sequencing Key Programming

If you program frequently performed key operations for the AUTO keys, you can enter those key operations simply by pressing the corresponding AUTO keys in key operations.

Procedure

Select "03 AUTO KEY" from the PGM2 window.

AUTO KEY

PUSH AUTO KEY

01

01

01 7 KEY
02 0 KEY
03 0 KEY
04 P00009
05 CA/AT

To program an automatic sequencing key as follows:

1. Press the automatic sequencing key which you want to program.

AUTO

2. Enter the desired sequence to use the automatic sequencing key in the programmed sequence.

700 → **9** → **CA/AT**

3. Press the automatic sequencing key again.

AUTO
1

4. Press the **CANCEL** key to finalize the programming.

Loading Dynamic UPC to the Main UPC File

The UPC master file (main file) can be updated by loading the data recorded in the dynamic UPC file to the UPC master file.

Procedure

For loading dynamic UPC:

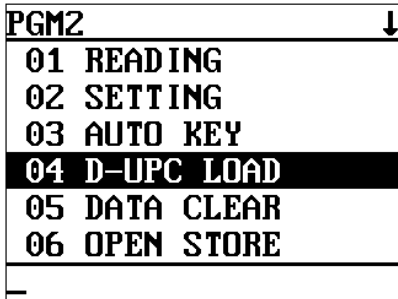

PGM2 ↓

01 READING
02 SETTING
03 AUTO KEY
04 D-UPC LOAD
05 DATA CLEAR
06 OPEN STORE

1. Select "04 D-UPC LOAD" from the PGM2 window.

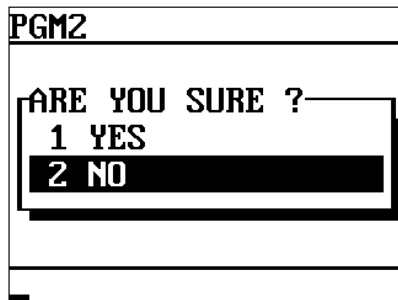

PGM2

ARE YOU SURE ?

1 YES
2 NO

2. Select "YES" or "NO", and press the key.

Reading of Stored Programs

You can read programs stored in the PGM1 or PGM2 mode.

■ Program reading sequence

To read those programs stored in the PGM1 or PGM2 mode, use the following procedure:

1. Place the mode key to the PGM1 or PGM2 position.
2. Select "01 READING" from the PGM1 or PGM2 mode window to display the items list.
3. Select an item listed in the table shown later.
4. Where "RANGE" and/or "PICK UP" are displayed on the screen, select either option. Select "RANGE" to read program by range, and "PICK UP" to read program by picking up codes. The procedure to specify a range or to pick up codes are the same as the one in sales report. On the table, for the item you can specify a range, "*1" is indicated, and for the item you can pick up codes, "*2" is indicated.

Item:	Description:	Available mode:
1 DEPARTMENT *1	Department	PGM1 or PGM2
2 PLU/UPC *2	PLU/UPC	PGM1 or PGM2
3 DYNAMIC UPC *2	Dynamic UPC	PGM1 or PGM2
4 LINK PLU TABLE *1	Link PLU table	PGM2
5 CONDIMENT TBL. *1	Condiment table	PGM2
6 MIX&MATCH	Mix-and-match table	PGM2
7 COMBO MEAL *1	Combo meal table	PGM2
8 UPC OTHER	UPC others	PGM2
9 SCALE TABLE	Scale table	PGM2
10 FUNCTION	Function	PGM1 or PGM2
11 MEDIA	Media key	PGM2
12 SERVER	Server	PGM1 or PGM2
13 OPTIONAL	Optional feature	PGM2
14 FUNCTION TEXT	Function text	PGM2
15 DEPT. GROUP	Department group	PGM2
16 PLU GROUP	PLU/UPC group	PGM2
17 SERVER GROUP	Server group	PGM2
18 TEXT	Text	PGM2
19 TAX	Tax	PGM2
20 GLU CODE	GLU	PGM2
21 CUSTOMER *1	Customer	PGM2
22 CUSTOMER PROG.	Customer programming	PGM2
23 NEGATIVE #	Negative no.	PGM2
24 POSITIVE #	Positive no.	PGM2
25 AUTO KEY	Automatic sequencing key	PGM2
26 MACRO KEY	Macro key	PGM2
27 CAPTURE KEY	Capture key	PGM2
28 CAPTURE JOB#	Capture job	PGM2
29 DEVICE CONFIG	Device configuration	PGM2
30 DIRECT KEY	Direct key	PGM2
31 FUNC. MENU KEY	Function menu key	PGM2
32 PLU MENU KEY	PLU menu key	PGM2

■ Sample printouts

• Departments (PGM1 or PGM2 mode)

Date	08/26/2002	8:06PM	Time
Machine number	123456#1004	JACK0001	Server name/server code
Consecutive number			
Operating mode*	*PGM2*		
Report type	DEPARTMENT		
Dept. code	D01	10.00	Key data entry job no.
Item label	HUMBURG	G1	Unit price
Tax status	T1 00	A00	Group no.
	000003 000	40	Age limitation
Server group no.	S1	KP00000	CVM control character
		L17/10	HALO/LALO
	D02	0.00	Print station
	DPT.02	G0	Function programming
Group discount status (1/2/3)	00	A00	0 0 0 0 3
	000001 000	00	Type of unit price entry (open & preset/preset/open/inhibit)
	S0 KP00000	L17/10	Gas/BR/Hash/Normal
	D03	0.00	SIF/SICS/Normal
	DPT.03	G0	Scale status (compulsory/enable/inhibit)
	00	A00	Tara table no.
	000001 000	00	Validation printing (compulsory/non-compulsory)
	D20	-0.00	Minus department
	DPT.20	G0	
	00	A00	
	000001 000	00	
	S0 KP00000	L17/10	

* When you take this report in the PGM1 mode, the PGM2 indication is replaced by a "PGM1."

• PLU/UPC (PGM1 or PGM2 mode)

08/26/2002 8:06PM
123456#1007 JACK0001

PGM2

Report type PLU/UPC

Dept. code

PLU code F*00001 (02) 0

Item label for price level 1 MILK

Zero price (allowed/disallowed) 1 1.25

Item label for price level 2 COKE

0 0.80

Item label for price level 3 COFFEE

0 2.50

Item label for price level 4 TEA

0 2.70

Item label for price level 5 WINE

0 5.00

Item label for price level 6 JUICE

0 1.50

Condiment table no. T1

Tax status 600 00 00 ADD

Mix & match table no. MOD COO 00

Link PLU table no. #00 TO 000 000002

Scale table no. F*00000 KP00000 PGD 40

Coupon object PLU S 0 M 0

Print station

Kitchen printer text for price 1 MK

Kitchen printer text for price 2 CK

Kitchen printer text for price 3 CF

Kitchen printer text for price 4 TE

Kitchen printer text for price 5 WN

Kitchen printer text for price 6 JC

F*00002 (01) / 0

Base q'ty

PLU's menu type
Blank : Normal PLU
L : Link PLU
C : Combo meal

Price level 1

Price level 2

Price level 3

Price level 4

Price level 5

Group nos.

Price level 6

Age limitation

Group discount status (1/2/3)

Key data entry job no.

CVM control character

Minimum stock q'ty

Priority group no.

Stock q'ty

Function programming
0 0 0 0 0 2

- └─ Mode parameter (open & preset/preset/open/inhibit)
- └─ Scale status (compulsory/allowed/prohibited)
- └─ Condiment entry to menu item (compulsory/non-compulsory)
- └─ Condiment type/non-condiment type
- └─ Price shift (compulsory/prohibited/allowed)
- └─ Repeat round (Yes/no)

3234567891082#(01) / 0

PARTS-E

1 1.70

0 0.00

0 0.00

0 0.00

0 0.00

0 0.00

PRTS-F

0 2.10

600 00 00 ADD

MOD COO 00

#00 TO 000 000002

F*00000 KP00000 PGD 00

S 0 M 0

PT-E

PT-F

(for UPC)

Blank: Auto delete

* : No delete

NOTE The UPC codes are printed out in the sequence shown below.

UPC-A
UPC-E
EAN-13
EAN-8

• Link PLU table (PGM2 mode)

08/26/2002	8:12PM
123456#1013	JACK0001
PGM2	
LINK PLU TABLE	Report type
#01	Link PLU table no.
	Assigned PLU codes
	P00011
	P00012
	P00013
	P00014
	P00015
#02	P00016
	P00017

• Mix & Match table (PGM2 mode)

08/26/2002	8:13PM	
123456#1015	JACK0001	
PGM2		
MIX&MATCH	Report type	
#01	Mix & Match table no.	
#02	Price	
#03	Base q'ty	
	/ 3	5.75
	/ 5	11.25
	/12	250.00

• Condiment table (PGM2 mode)

08/26/2002	8:12PM
123456#1014	JACK0001
PGM2	
CONDIMENT TBL.	Report type
#01 /3	Condiment table no.
	Assigned PLU codes
	P00007
	P00008
	P00009
	P00010
	#02
	Next table#
#02 /2	P00003
	P00004
	P00005
	Number of repeats

• Dynamic UPC (PGM2 mode)

08/26/2002	8:10PM
123456#1012	JACK0001
PGM2	
DYNAMIC UPC	
5067891234506#(01) / 0	
ITEM-N1	
1	1.10
ITEM-N2	
0	1.50
ITEM-N3	
0	1.20
ITEM-N4	
0	2.10
ITEM-N5	
0	1.70
ITEM-N6	
0	1.30
G00 00 00 A00	
M00 C00 00	
#00 TO 000 000002	
P00000 KP00000 PG0 00	
IT-1	
IT-2	
IT-3	
IT-4	
IT-5	
IT-6	

• Combo meal table (PGM2 mode)

08/26/2002	8:15PM	
123456#1018	JACK0001	
PGM2		
COMBO MEAL		Report type
#01	CHICKEN COMBO	Combo table no. Combo meal text
	CKN CB	Kitchen printer text
	COO 0 00	Condiment entry to menu item (compulsory/non-compulsory)
KP00000	PGO 00	Print station/Priority group no./CVM control character
	F00018	Associated PLU text
	1.20	Associated PLU unit price (PRICE1)
	1.30	Associated PLU upsize price (PRICE2)
	F00019	
	2.10	
	2.15	
	F00020	
	1.75	
	1.75	

Condiment table no.

• Scale tare table (PGM2 mode)

08/26/2002	8:16PM	
123456#1019	JACK0001	
PGM2		
SCALE TABLE		Report type
#1	2.75	Scale table no. Weight
#2	3.50	
#3	12.00	
#4	0.00	
#5	0.00	
#6	0.00	
#7	0.00	
#8	0.00	
#9	0.00	

• UPC other (PGM2 mode)

08/26/2002	8:16PM	
123456#1020	JACK0001	
PGM2		
UPC OTHER		
UPC NON-PLU		
20	5	4 0 1 2
02	4	5 0 1 2
UPC DELETE		
		99

• Functions (PGM1 or PGM2 mode)

08/26/2002 8:18PM		123456#1022 JACK0001	
PGM2			
FUNCTION			Report type
(-) 1	-1.00		Sign (plus/minus)
I T1	L17		Amount
000	00		Function text
	P00001		Key data entry job no.
	F00002		Associated PLUs (max. 20 items)
%1	-10.00%		
S	L100.00%		HALO
000	00		Tax status
GDISC%1	-0.00%		
	L100.00%		HALO
GD1 ST	00		Type
GDISC%2	-0.00%		I=Item
	L100.00%		S=Subtotal
GD2 ST	00		Key data entry job no.
GDISC%3	-0.00%		
	L100.00%		
GD3 ST	00		
GAS(-)1	0.000		
GAS1 ST			

GAS19 ST			
GRATUITY	-0.00%		
	L17		
CA TIP	0.00%		
	L18		
CH TIP			
***RA	00		Key data entry job no.
	000		
***RA2	L18		
	00		
	000		
***PD	L18		
	00		
***PD2	L18		
	00		
M-TAX	L17		
	00		
TAX DEL.	00		
NO SALE	00		
DIR VD	00		
PAST VD	00		
SETL VD	00		
REFUND	00		
RETURN	00		

• Media (PGM2 mode)

08/26/2002 8:23PM		123456#1023 JACK0001	
PGM2			
MEDIA			Report type
CASH	KP0000 L18		Print station
	0000000000 00		HALO
	00000000		Function text
	000000000001		Function programming (2)

CHECK1	KP0000 L18		Function programming (3)
	0000000000 00		
	0000000000		Function programming (1)/
	000000000001		Key data entry job no.

CHARGE1	KP0000 L18		Function text (gross)
CHARGE1-	0000000000 00		Function text (refund)
	0000000000		
	000000000001		

FS TEND	KP0000		
	0000000000 00		
	00		
	000000000001		
CONV 1	0.0000		Rate
CONV 2	0.0000		
CONV 3	0.0000		
CONV 4			
EAT IN 1			Tax status
EAT IN 2			
EAT IN 3			
SERVICE	KP0000		
	000 00		
	000000000001		Function programming/
FINAL	KP0000		Key data entry job no.
	000 00		
	000000000001		
***CID	9999999.99		Sentinel
CHK/CG	999999.99		HALO
CA/CHK1	999999.99		
	00000001		
CA/CHK2	999999.99		
	00000001		
CA/CHK3	999999.99		
	00000001		
CA/CHK4	999999.99		
	00000001		
CA/CHK5	999999.99		
	00000001		

• Server (PGM1 or PGM2 mode)

```

08/26/2002      8:27PM
123456#1032    JACK0001

      *PGM2*
SERVER          Report type
                Server code
SRV#0001      JACK  Server name
RANGE 1-10    Linked GLU
GLU#1 33      codes
GLU#2 35
0.00%        OD1(0000)
SRV#0002      JIM  Function
RANGE 11-20   programming
GLU#1 30      Net sales %
    
```

```

SRV#0014      SERV.014
RANGE 1-9999
0.00%        OD1(0000)
SRV#0015      SERV.015
RANGE 1-9999
0.00%        OD1(0000)
    
```

• Customer (PGM2 mode)

```

08/26/2002      8:27PM
123456#1033    JACK0001

      *PGM2*
CUSTOMER
#0000000000020
NAME-20
ADDRESS-20
#0000000000075
NAME-75
ADDRESS-75
    
```

• Customer control (PGM2 mode)

```

08/26/2002      8:28PM
123456#1034    JACK0001

      *PGM2*
CUSTOMER PRDG.

99
    
```

• Negative no. (PGM2 mode)

```

08/26/2002      8:28PM
123456#1035    JACK0001

      *PGM2*
NEGATIVE#
#000000000000123    0
#000000000000135    1
#0000000000003050    0
    
```

• Positive no. (PGM2 mode)

```

08/26/2002      8:28PM
123456#1036    JACK0001

      *PGM2*
POSITIVE#
#0000000000003030
#0000000000006651
#0000000000007752
    
```

• Optional features (PGM2 mode)

```

08/26/2002      8:28PM
123456#1037    JACK0001

      *PGM2*
OPTIONAL ----- Report type

OPTIONAL
FUNC.PROHIBIT
OP%/Z REPORT    ENABLE ----- Setting
PAID OUT        PUBLIC
RFND SALES      PUBLIC
(-) ENTRY       PUBLIC
RF/RETURN       PUBLIC
1st LAST VD     ENABLE
DIRECT VD       PUBLIC
INDIR. VD       PUBLIC
SBTL VOID       PUBLIC
VOID MODE       PUBLIC
NO SALE         PUBLIC
PAY WHEN ST=0   ENABLE
TIP PAID        PUBLIC
TRANS IN/OUT    PUBLIC
P.VD IN GLU     ENABLE
OPEN GLUDISP    DISABLE
UPC LEARNING    ENABLE
PRICE CHANGE    PUBLIC
CUSTOMER DPN    PUBLIC

FUNC.SELECT1
ITEM VP         ENABLE
RF/RT VP        NON-COMPUL.
(-) VP          NON-COMPUL.
CA/CHK VP       NON-COMPUL.
RA VP           NON-COMPUL.
PD VP           NON-COMPUL.
TIP VP          NON-COMPUL.
L.SFT TYPE      AUTO
LEVEL SHIFT     PUBLIC
PR.SFT TYPE     AUTO
PRICE SHIFT     PUBLIC
RETURN TO L1    BY ITEM
RETURN TO P1    BY ITEM

FUNC.SELECT2
SEATH#          INHIBIT
COVER CT        NON-COMPUL.
TIP ENTRY       AMOUNT
SRVR DRW        INHIBIT
SHIFT KEY ACT   CAPS
AUTO HOURLY     DISABLE
COND.CANCEL     PUBLIC
ISEN PRICE      COMPUL.

```

```

CUSTOMER DATA  DETAIL
SERVER POPUP    DISABLE
T-LOG FULL      CONTINUE
CAPTURE FULL    CONTINUE

PRINT SELECT
PURCHASE NO.    NO
TIME            YES
JOURNAL SEL.    FULL
JOURNAL SIZE    NORMAL
ITEM ON BILL    YES
SHARE%          YES
REDORDER KP MSG CHARGE
CUSTOMER REP.   CHARGE
BIRTHDAY        YES
TX STATUS RJ    YES
TX STATUS BILL  YES
TX STATUS KP    YES

INTERVAL TIMER
TILL TIMER      0
SCREEN SAVE     0

DEF.MENU LEVEL
DEF.MENU LEVEL  1

AVAILABLE GLU#
START CODE      1
END CODE        9999

BILL NUMBER
BILL NUMBER     0000

D SKIP
SERVER          SKIP
TRANSACTION     SKIP
DEPARTMENT      SKIP
PLU/UPC         SKIP
HOURLY          SKIP
DAILY NET       SKIP

HOURLY RPT
MEMORY TYPE     30
STARTING TIME   00

```

```

STACKED RPT
1
DEPARTMENT      01-20
PLU BY DEPT     01
DEPT.GR.TOTAL

2
PLU CATEGORY    5.00 - 15.00
HOURLY
GLU             1-9999

```

To be continued

To be continued

• Function text (PGM2 mode)

```

08/26/2002      8:36PM
123456#1038    JACK0001

      *PGM2*
FUNCTION TEXT
NET1      NET1
TAX1 ST   TAX1 ST
GRS TAX1  GRS TAX1
RFD TAX1  RFD TAX1
TAX1      TAX1
TX1 EXPT  TX1 EXPT
TAX2 ST   TAX2 ST
GRS TAX2  GRS TAX2
RFD TAX2  RFD TAX2
TAX2      TAX2
TX2 EXPT  TX2 EXPT
TAX3 ST   TAX3 ST
GRS TAX3  GRS TAX3
RFD TAX3  RFD TAX3
TAX3      TAX3
TX3 EXPT  TX3 EXPT
TAX4 ST   TAX4 ST
GRS TAX4  GRS TAX4
RFD TAX4  RFD TAX4
TAX4      TAX4
TX4 EXPT  TX4 EXPT
GRS MTAX  GRS MTAX
RFD MTAX  RFD MTAX
GST EXPT  GST EXPT
PST TTL   PST TTL
GST TTL   GST TTL
TTL TAX   TTL TAX
FS TX1    FS TX1
FS TX2    FS TX2
FS TX3    FS TX3
NET       NET
NET2     NET2
COMB01   COMB01

```

Report type
Function text (default)
Text (preset)

```

XB TTL TL   XB TTL TL
BTTL(-)    BTTL(-)
XGAS TL    XGAS TL
GAS(-)     GAS(-)
SUBTOTAL   SUBTOTAL

```

```

MOSE ST     MOSE ST
***TOTAL   ***TOTAL
CHANGE      CHANGE
DUE         DUE
TIP DUE     TIP DUE
TRAY TL     TRAY TL
FS ST       FS ST
FS TEND     FS TEND
FS CG       FS CG
ITEMS       ITEMS
BALANCE     BALANCE
COPY        COPY
B.T.        B.T.
B.S.        B.S.
SLIP PR.    SLIP PR.
FIN.BAL     FIN.BAL
BAL FWD     BAL FWD
CLOSE CK    CLOSE CK
OPEN CK     OPEN CK
(%)SALES    (%)SALES
SEAT#       SEAT#
VAT EXPT    VAT EXPT
IND.PAY     IND.PAY
TARE WT.    TARE WT.
RCP S.W.    RCP S.W.
FREE GLU    FREE GLU
WASTE       WASTE
AVE SALE    AVE SALE
ST(-) TL   ST(-) TL
ST % TL     ST % TL
(-) TL     (-) TL
% TL       % TL
GDISC%TL   GDISC%TL
GASDISTL   GASDISTL
CASH TL     CASH TL
RA TL       RA TL
PD TL       PD TL
CA/CK TL   CA/CK TL
CONV TL     CONV TL
CHR TL      CHR TL
CHECK TL    CHECK TL
COMBO       COMBO
WASTE       WASTE
RF          RF
CP          CP
NET SLS     NET SLS
COMBO TL   COMBO TL
WASTE TL   WASTE TL
RF TL      RF TL
NET TL     NET TL
TBL#       TEL#
SIGN-ON    SIGN-ON
SIGN-OFF   SIGN-OFF

```

To be continued

• Department group text (PGM2 mode)

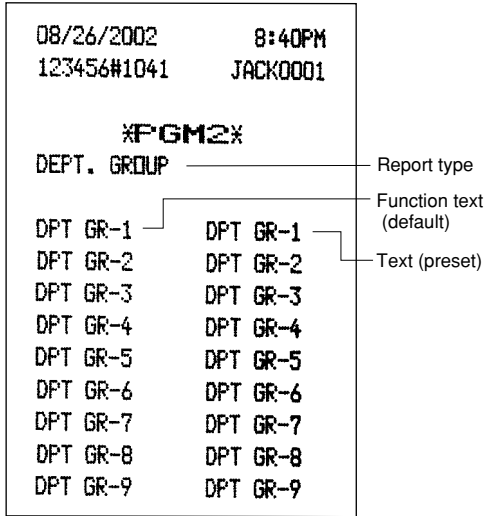

• Server group text (PGM2 mode)

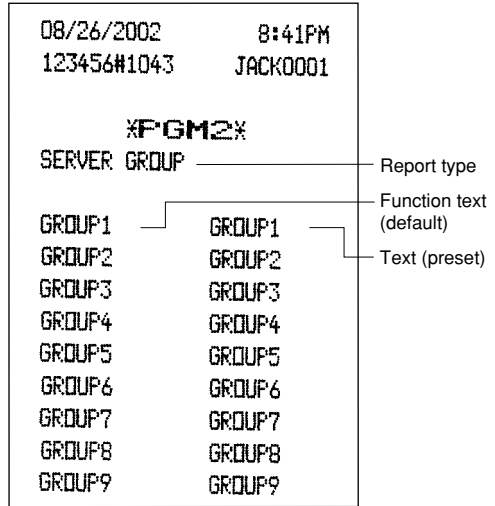

• PLU group text (PGM2 mode)

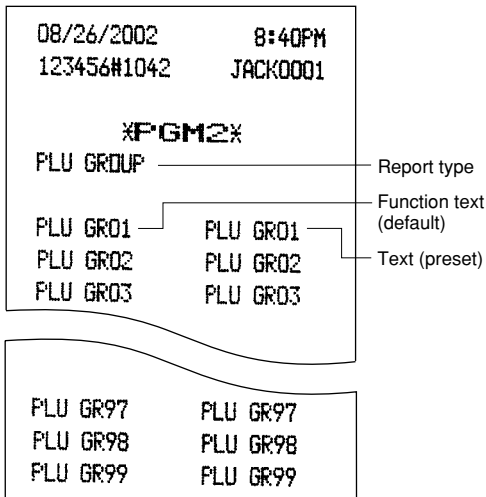

• Logo text (PGM2 mode)

```

08/26/2002      8:42PM
123456#1044     JACK0001

      *PGM2*
TEXT ----- Report type

RECEIPT LOGO
  SHARP
PRESENTS THE
UP-600
  SHARP
IS THE
BEST
----- Receipt logo text

VP TEXT

FOR DEPOSIT ONLY

BILL LOGO
HEADER ----- Header text for
bill printer

FOOTER ----- Footer text for
bill printer

MESSAGE TEXT
1 MESSAGE 1      00
2 MESSAGE 2      00
3 MESSAGE 3      00
4 MESSAGE 4      00
5 MESSAGE 5      00
    
```

• GLU code (PGM2 mode)

```

08/26/2002      8:42PM
123456#1045     JACK0001

      *PGM2*
GLU CODE ----- Report type

GLU
----- Start code
1-9999 ----- End code
    
```

• Tax rate (PGM2 mode)

```

08/26/2002      8:45PM
123456#1050     JACK0001

      *PGM2*
TAX ----- Report type

TAX1 ----- Tax no.
  6.0000 % Rate
  / 1.00 Cycle
  1 0.11 Lower tax limit
  2 0.23
  3 0.39
  4 0.57 Breakpoint
  5 0.73 amount
  6 0.89
  7 1.11

TAX2 4.0000 % Lower tax limit
      0.12

TAX3 5.0000 %
      0.20 Doughnut tax
EXPT COUNT ----- exempt count
TAX4 6.0000 %
      0.30
    
```

• AUTO key (PGM2 mode)

```

08/26/2002      8:46PM
123456#1053     JACK0001

      *PGM2*
AUTO KEY ----- Report type

#01 ----- AUTO key no.
      2 KEY
      PLU
      1 KEY
      8 KEY Entry sequence
      PLU programmed

#02
      3 KEY
      PLU

#24 -----
#25 -----
    
```

• Macro key (PGM2 mode)

```

08/26/2002      8:48PM
123456#1056     JACK0001

      *PGM2*
MACRO KEY

MACRO#1
      X1Z1
      AUTO3
      X1Z1
      AUTO5

MACRO#2
      X2Z2
      AUTO6

MACRO#3
      X2Z2
      AUTO7
      X2Z2
      AUTO8

MACRO#4
      PGM2
      AUTO10
    
```

• Capture key (PGM2 mode)

```

08/26/2002      8:48PM
123456#1057     JACK0001

      *PGM2*
CAPTURE KEY

#1      CAPTURE01
              10 00
#2      CAPTURE02
              10 00
#3      CAPTURE03
              10 00
#4      CAPTURE04
              10 00
#5      CAPTURE05
              10 00
#6      CAPTURE06
              10 00
#7      CAPTURE07
              10 00
#8      CAPTURE08
              10 00
#9      CAPTURE09
              10 00
#10     CAPTURE10
              10 00
    
```

• Function menu key (PGM2 mode)

```

08/29/2002      2:45PM
123456#2025     JACK0001

      *PGM2*
FUNC.MENU KEY

01      %1
02      %2
03      %3
04      %4
05      %5
06      (-)1
07      (-)2
08      (-)3
09      (-)4
10      (-)5
11      GDSC%1
12      GDSC%2
13      GDSC%3
14      BIRTH
15      CAP.1
    
```

• Capture job no. (PGM2 mode)

```

08/26/2002      8:48PM
123456#1058     JACK0001

      *PGM2*
CAPTURE JOB#

#01
      MSG1
              1 13 00 1
      MSG2
              2 13 00 1
      MSG3
              0 13 00 1
      MSG4
              0 13 00 1

#02
      MSG1
              0 13 00 1
      MSG2
              0 13 00 1
      MSG3
              0 13 00 1
      MSG4
              0 13 00 1
    
```

• Device configuration (PGM2 mode)

```

08/26/2002      8:55PM
123456#1060    JACK0001

      *PGM2*
DEVICE CONFIG ----- Report type

R/J PRINTER ----- Printer type
                                0 Line feed count
BILL(SLIP) ----- for tray subtotal
REPORT PRINTER: T#000-C#0
                                NO
                                PRINT
                                BUILT-IN
VALIDATION(VP) T#000-C#0
                                BUILT-IN
                                1
KP#1 -----

KP#9 -----
CAT#1 -----
CAT#2 -----
BCR(SCANNER) -----
SCALE -----
COIN DISP. -----
ONLINE -----
CVM DATA I/F -----
    
```

• PLU menu key (PGM2 mode)

```

08/26/2002      9:00PM
123456#1066    JACK0001

      *PGM2*
PLU MENU KEY

#01      PLU MENU01 ----- Title
          F*00001 ----- Menu PLU
          F*00002
          F*00003
          F*00004
          F*00005
          F*00006
          F*00007
          F*00008
          F*00009
          F*00010
#02      PLU MENU02
          F*00011
          F*00012
          F*00013
          F*00014
          F*00015
          F*00016
          F*00017
          F*00018
          F*00019
          F*00020

#05      PLU MENU05
          F*00001
          F*00012
          F*00003
          F*00014
          F*00005
    
```

• Direct key (PGM2 mode)

```

08/26/2002      9:01PM
123456#1067

      *PGM2*
DIRECT KEY ----- Report type
                                Key no.
001 -----
002 -----

047      D01 ----- Dept code
048      D02
049      D03
050      D04
051      D05

080 -----
081 -----
082 -----
    
```

Data Clear

The DATA CLEAR is chiefly used for clearing data such as report data e.g. hourly report, daily net sales, or electronic journal file data in the event some system trouble occurred.

Use the following procedure to perform the data clear operation only when instructed by your authorized SHARP dealer.

Procedure

PGM2	↓
01 READING	
02 SETTING	
03 AUTO KEY	
04 D-UPC LOAD	
05 DATA CLEAR	
06 OPEN STORE	



DATA CLEAR	↓
1 T-LOG	
2 CAPTURE DATA	
3 TRANSACTION	
4 HOURLY	
5 DAILY NET	
6 SIGN ON FLAG	

The screen continues.

1. In the PGM2 mode menu, select "5 DATA CLEAR".
 - The DATA CLEAR window will appear.

2. Select the desired operation.

Universal Product Code (UPC) or European Article Number (EAN)

■ UPC or EAN code

Your machine can transact the following codes:

- UPC-A (Number system character: 0, 2, 3, 4)
- UPC-E
- EAN-8
- EAN-13
- Internal code EAN-8/EAN-13

For the codes used for in-store marking, there are two kinds of PLU type (treated as a code like PLU code) and Non-PLU type (price/quantity information is included in the code).

When a code is a non-PLU type, the price/quantity in the code is read for sales entries (in case of quantity, "quantity multiplies preset unit price" is processed to obtain the price.)

UPC-A

- Number system character: 0 <used in the source marking>
- Number system character: 3 <used as NDC or HRI>

For entry, a full 12 digit number or 11 digit number (omitting the check digits) must be entered.

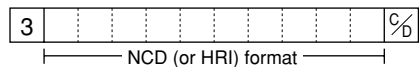
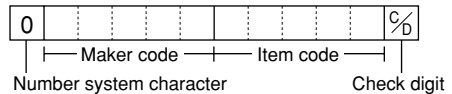

- Number system character: 2 <In-store marking Non-PLU type> You can program the format in "EAN NON-PLU" in ARTICLE setting.
- Number system character: 4 <In-store marking PLU type>

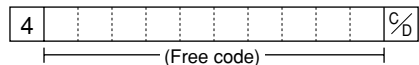
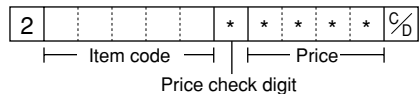

For entry, a full 12 digit number, 11 digit number (omitting the check digit), or a leading zero plus 12 digit number must be entered. (Any number is allowed for the digits marked with *, and on the receipt/journal, non-PLU type code is printed like 2020008**** (****: price information).)

UPC-E

- UPC-E is a zero-suppressed version of UPC-A that conforms to the UPC-E Standards. This code is used for marking small packages.



For entry, a 6 digit number or a leading zero plus 6 digits number must be entered.

EAN-8

- Ordinary EAN-8 code (flag: neither 0 nor 2) <used in the source marking>

For entry, a full 8 digit number must be entered.

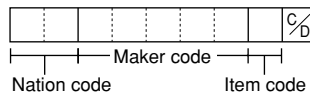

- Internal code (flag 2) <in-store marking non-PLU short type> Program the format in "EAN NON-PLU" in ARTICLE setting.
- Internal code (flag 0) <in-store marking PLU short type>

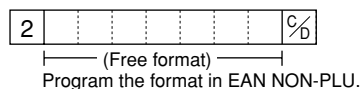

For entry, a full 8 digit number must be entered. On the receipt/journal, non-PLU type code is printed like 208**** (****: price/quantity information)

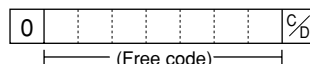

EAN-13

- Ordinary EAN-13 code (used in the source marking)
- Specific EAN-13 code (flag 977, 978, 979) (used in the source marking: ISBM, ISSN)

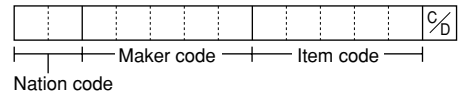

For entry, you must enter a full of 13 digit number.

- Internal code (used for in-store marking, the flag character number: 20 through 29 and 02)
Program the format in “EAN NON-PLU” in ARTICLE setting.

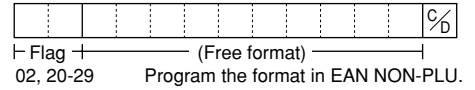

■ Add-on code

UPC-A and EAN-13 may be followed by a two digit number or a five digit number as an add-on code, except the UPC-A without a check digit plus two or five digit add-on code.

Therefore, the total number of digits enterable for sales entries are as shown below:

Code entry	No add-on code	2-digit add-on code	5-digit add-on code
UPC-A	12	14	17
UPC-A w/leading zero	13	15	18
UPC-A w/o check digit	11	–	–
UPC-E	6	–	–
EAN-8	8	–	–
EAN-13	13	15	18

NOTE

Your register automatically judges the add-on code in an EAN code entered from the total number of digits and the flag.

■ UPC file

Your POS terminal has a UPC main file and can provide a Dynamic UPC (D-UPC) file.

UPC main file

In general use, all UPC items are managed in the UPC main file.

The programming data and sales information is recorded in the UPC main file.

Dynamic UPC file

If the dynamic UPC file is allocated, the items entered by the UPC learning function (refer to “UPC learning function” section.) are saved in this file temporarily. (If not generated, they are directly saved in the UPC main file.) The data saved temporarily can be transferred to the UPC main file when necessary by executing the D-UPC LOAD in the PGM2 mode.

If you want to use the dynamic UPC file, please consult your authorized SHARP dealer.

15

Operator Maintenance

In Case of Power Failure

When power is lost, the POS terminal retains its memory contents and all information on sales entries.

- When power failure is encountered while the POS terminal is at an idle state or during an entry, the POS terminal returns to the normal state of operation after power recovery.
- When a power failure is encountered during a printing cycle, the register prints "======" and then carries out the correct printing procedure after power recovery. (See the sample print.)

08/26/2002	9:15PM	
123456#1069	JACK0001	
FLO0002	\$2.50	
DPT.05	\$8.20	
FLO0005 =====		Power failure symbol
FLO0005	\$7.20	Print after power recovery
CASH	\$17.90	

In Case of Printer Error

If the printer's motor happens to lock, the printing stalls and intermittent beeping starts. You must, first of all, cut the power supply and repair the paper jam. Then, when the cord is plugged into a receptacle, message "PRINTER ERR" is displayed.

Feed the roll paper to the proper position and depress the key. The register carries out the power failure symbol and continues printing.

Paper roll near-end sensing function (only for journal paper) <option>

When the journal paper roll comes near the end or is not loaded, the machine senses this condition and sounds an alarm, displaying the error message "PAPER EMPTY". At this time, clear the alarm with the key and replace the paper roll as soon as possible. The following entry can be made after clearing the alarm. However, since this function works each time one transaction is completed, the alarm sound will be emitted again as the following transaction is completed unless the paper roll is replaced.

If you want to use this function, consult your dealer.

- The sensing position depends upon the size of the paper tube. Therefore, it is advisable to use paper rolls - whose paper tube is 18 mm in O.D. and 12 mm in I.D. - specified by SHARP.
- If sensing occurs too early or late, contact your dealer.

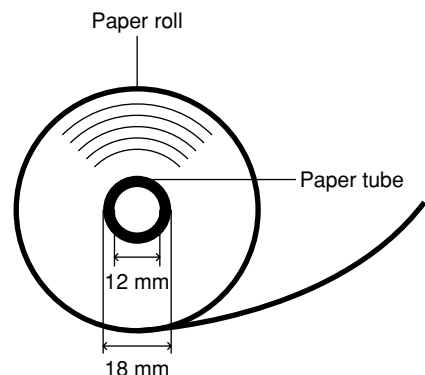

Installing and Removing the Paper Roll

■ Recording paper specifications

Be sure to use paper rolls specified by SHARP.

The use of any other paper rolls than specified could cause paper jamming, resulting in a POS terminal malfunction.

Paper specification

Paper width:	1.75 ± 0.02 in. (44.5 ± 0.5 mm)
Max. outside diameter:	3.27 in. (83 mm)
Weight:	52.3 – 64.0 g/m ² (45 – 55 kg/1000 sheets/788 x 1091 mm ²)
Quality:	bond paper
Paper tube:	0.71 in. (18 mm)

- Be sure to set paper roll(s) prior to using your machine, otherwise it could malfunction.

(How to set the paper roll)

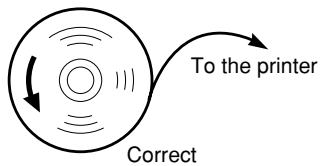
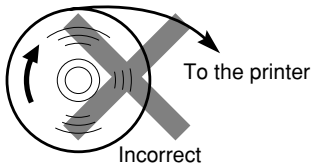

(How to cut the paper end)

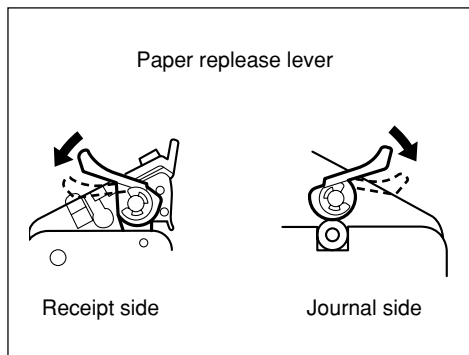
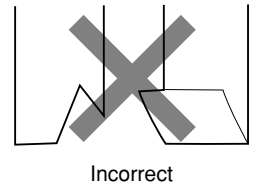
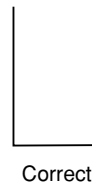

To release the paper, press the paper release lever down. It is also used for removing a paper jam. The method for removing a paper jam is described in “Removing a paper jam” later in this section.

■ Installing the paper roll

Installing the receipt paper roll

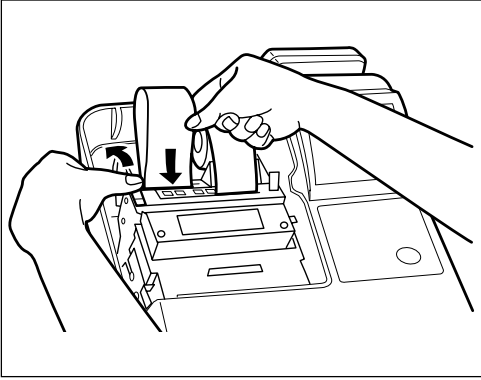

1. Open the printer cover. Set the paper roll correctly as illustrated and drop it into the printer.
2. Press the receipt paper release lever down and insert the paper end into the paper chute of the printer. Pull the paper end that has come out of the printer, holding down the lever.
3. Advance the paper by a required length by pressing the receipt paper feed key.

Installing the journal paper roll

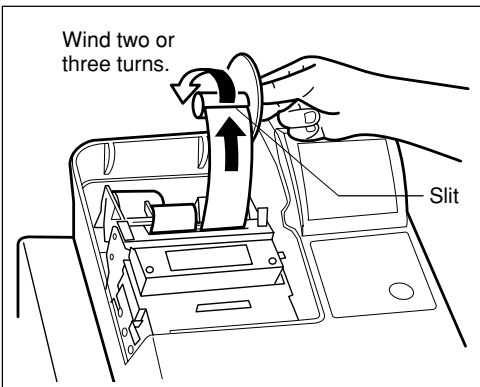

1. Open the printer cover. Set the paper roll correctly and drop it into the printer.
2. Press the journal paper release lever down, insert the paper end that has come out of the printer into the slit in the paper take-up spool, wind it two or three turns around the spool shaft, and set the spool on the bearing.

NOTE

Make sure the ink ribbon cassette has been mounted on the printer when installing the receipt paper roll or the journal paper roll.

■ Removing the paper roll

When a colored dye appears on the paper roll, it is time to replace the existing paper roll. Replace the paper roll with a new one.

Removing the receipt paper roll

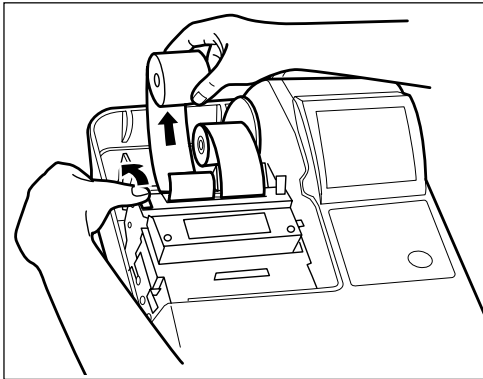

1. Open the printer cover.
2. Press and hold the receipt paper release lever down and draw out the existing paper roll from the paper roll location.

NOTE Be sure to pull the roll in the direction of the arrow.

Removing the journal paper roll

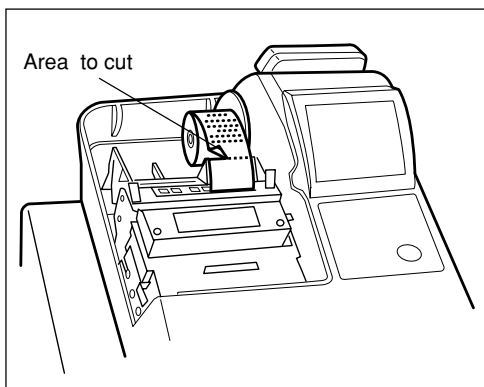

1. Press the journal paper feed key to advance the paper by several lines and then cut it.

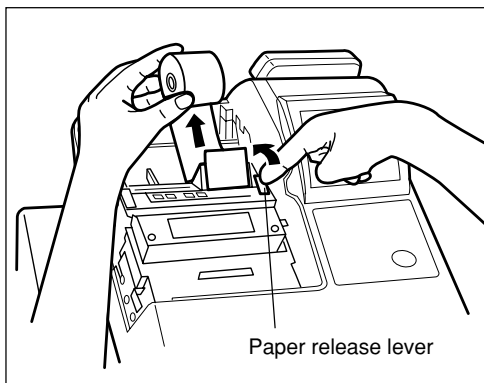

2. Press and hold the journal paper release lever down and remove the existing paper roll from the paper roll location.

NOTE Be sure to pull the roll in the direction of the arrow.

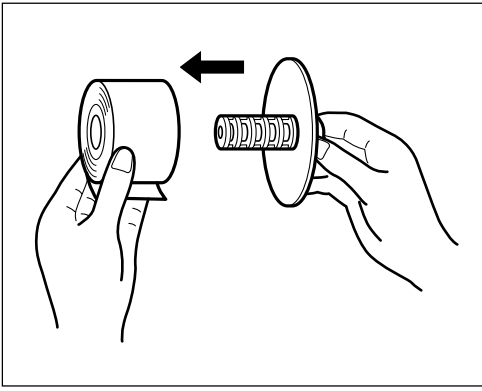

3. Remove the paper roll from the take-up spool.

■ Removing a paper jam

1. Open the printer cover.
2. Pressing the receipt and journal paper release levers at the same time, lift part (A) up. (See the drawing below.)
3. Remove the paper jam.
4. Replace part (A) gently.
5. Reset the paper roll correctly following the steps shown in "Installing the paper roll".
6. Close the printer cover.

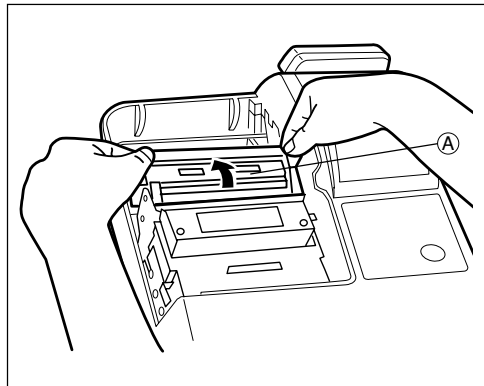
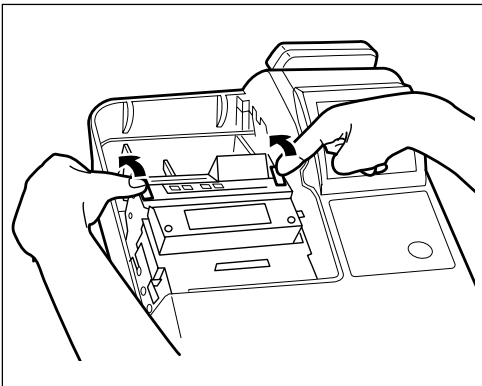

Installing the ink ribbon cassette

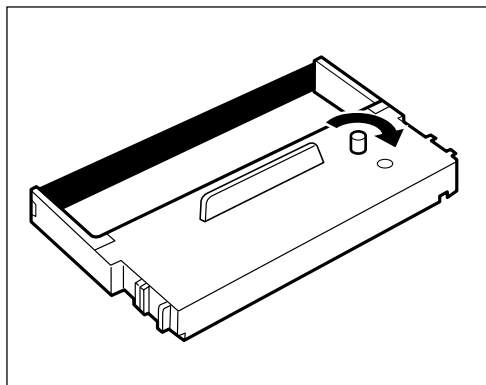

1. Open the printer cover and remove the ribbon cover.
2. Rotate the knob on the ink ribbon cassette in the direction of the arrow to stretch the ribbon tight.

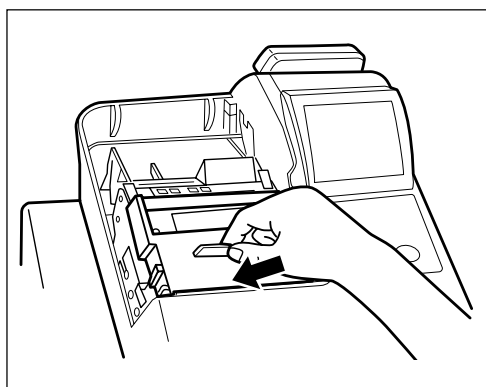

3. Put the ink ribbon cassette in the location indicated in the figure at left and fix it by using the right and left guides.
4. Rotate the knob two or three turns in the direction of the arrow to make sure it rotates smoothly. Also, make sure the ribbon is not folded.

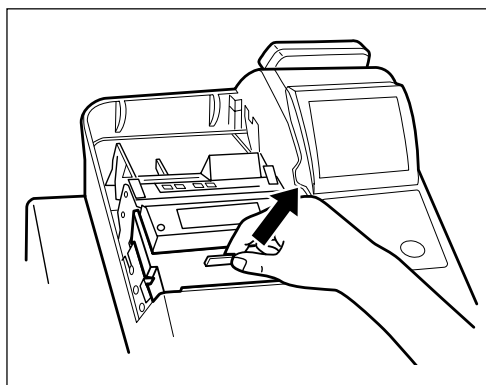

5. To remove the cassette, lift it up.

Precautions:

- Be sure to use an ink ribbon cassette specified by SHARP. The use of any ink ribbon cassette other than specified could cause troubles in the printer.
- After opening the parcel, be careful not to make the surface of the ink ribbon dirty, and install it soon.
- If you preserve the ink ribbon cassette for a long time, the ink will be dry and the ink ribbon cassette's life will be shortened. Please use it soon. If you do not use it soon, put it in an airtight receptacle and preserve it in a cool and dark place. Do not leave it in a location that is subject to high humidity and direct radiation.

Removing the Till and the Drawer

The till in the POS terminal is detachable. After closing your business for the day, remove the till from the drawer and keep the drawer open. To detach the drawer, pull it forward fully with the till removed, and remove it by lifting it up.

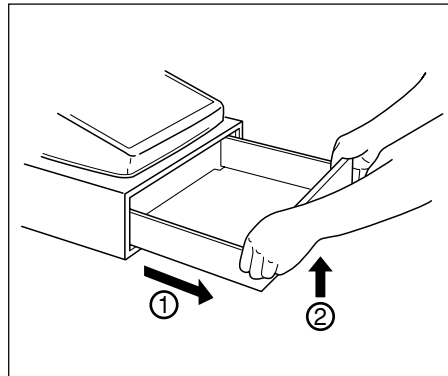
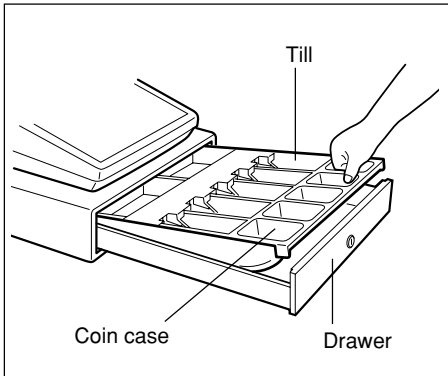

Operating the Drawer by Hand

The drawer automatically opens at the end of a sales transaction. However, when power failure is encountered or the machine becomes out of order, insert the key into the drawer lock and turn it 45 degrees clockwise. (See the figure below.)

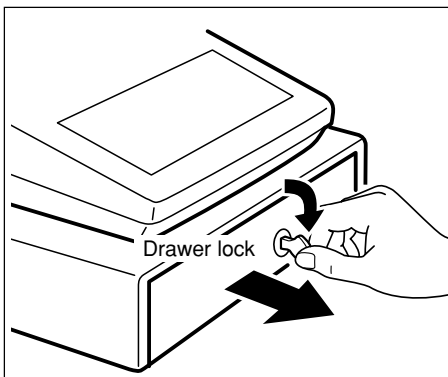

Before Calling for Service

The malfunctions shown in the left-hand column below, labeled “Fault,” do not necessarily indicate functional faults of the machine. It is therefore advisable to refer to the “Checking” section shown in the right-hand column before calling for service.

Fault	Checking
<ul style="list-style-type: none"> The display is not illuminated even when the mode switch is turned to any other position than “OFF”. 	<ul style="list-style-type: none"> Is power supplied to the electric outlet? Is the power cord plug out or loosely connected to the electrical outlet? Is the power switch in the “ON” position? Is the contrast control adjusted correctly? Is the terminal in screen-save mode?
<ul style="list-style-type: none"> The display is illuminated, but the whole machine refuses entries. 	<ul style="list-style-type: none"> Is a server code assigned to the POS terminal? Is the mode switch set properly at the “REG” position?
<ul style="list-style-type: none"> No receipt is issued. 	<ul style="list-style-type: none"> Is the receipt paper roll properly installed? Is there a paper jam? Is the receipt function in the “OFF” status?
<ul style="list-style-type: none"> No journal paper is taken up. 	<ul style="list-style-type: none"> Is the take-up spool installed on the bearing properly? Is there a paper jam?
<ul style="list-style-type: none"> Printing is unusual. 	<ul style="list-style-type: none"> Is the ink ribbon cassette installed properly? Is the ink ribbon life completed?

16 Options

List of Options

For your UP-600 POS terminal, the following options are available:

For details, contact your authorized SHARP dealer. Do not try to install any options yourself.

- RAM memory board models UP-S02MB, UP-S04MB
- Remote drawer model ER-03DW or ER-04DW
- Magnetic card reader model UP-E13MR
- Remote customer display model UP-P16DP (Pole type)
- Two-port RS-232 interface model ER-A5RS
- Barcode reader model ER-A6HS1
- Key kit models
By using the following key kits, you can change the keyboard layout of your POS terminal including the expansion of the number of departments.
ER-11KT7: 30 regular size key kits
ER-12KT7: 30 1 x 2 size key kits
ER-22KT7: 10 2 x 2 size key kits
ER-11DK7G: 30 regular size dummy key kits
ER-51DK7G: 10 5 x 1 size dummy key kits

17

Specifications

Model:	UP-600	
Dimensions:	17.5 (W) x 19.1 (D) x 12.3 (H) in. (445 (W) x 485 (D) x 312 (H) mm)	
Weight:	37 lbs. (16.8 kg)	
Power source:	120 V AC \pm 10%, 60 Hz	
Power consumption:	Stand-by:	16W
	Operating:	51W (max.)
Working temperatures:	32 to 104°F (0 to 40°C)	
Electronics:	LSI (CPU) etc.	
Built-in battery:	Rechargeable battery pack, memory holding time of about 1 month (with fully charged built-in battery pack, at room temperature)	
Display:	Operator display:	LCD display 83.18 (W) X 55.18 (H) (0.24 X 0.21 mm/pixel) Dark blue and white
	Customer display:	7-segment display (7 positions)
Printer:	Type:	2-station serial dot-matrix (7 x 7 font) printer
	Printing speed:	Approx. 3.0 lines/second
	Printing capacity:	24 digits each for receipt and journal paper
	Other functions:	<ul style="list-style-type: none"> • Logo message function • Receipt (ON-OFF) function, journal selective function • Receipt and journal independent paper feed function • Validation printing function
Ink ribbon: (Cassette type)	Color:	Purple (single color)
	Width:	17/32 in. (13 mm)
	Length:	29 ft. 6 in. (9 meters)
Paper roll:	Width:	1.75 \pm 0.02 in. (44.5 \pm 0.5 mm)
	Max. diam.:	3.27 in. (83 mm)
	Weight:	52.3 – 64.0 g/m ² (bond paper)
Cash drawer:	7 slots for bill and 5 for coin denominations	
Accessories:	Manager key	2
	Submanager key	2
	Operator key	2
	Printer cover lock key	2
	Ink ribbon cassette	1
	Paper roll	2
	Take-up spool	1
	Leaflet	1 copy
	Drawer lock key	2
Ferrite cores	3 (used for communications cabling installation)	

* Specifications and appearance subject to change without notice for improvement.

NOTICE

BE SURE TO ASK YOUR AUTHORIZED SHARP DEALER ABOUT THE WARRANTY THAT YOUR SELLING DEALER EXTENDS TO YOU. In order to assure you, the end-user, of warranty protection, Sharp extends a limited warranty to each of its authorized dealers, and in turn requires each of its authorized dealers to extend its own warranty to you on terms that are no less favorable than those given to the dealer by Sharp. You should be aware, however, that Sharp does not itself extend any warranties, either express or implied, directly to you, the end-user, and no one is authorized to make any representations or warranties on behalf of Sharp. Specifically, SHARP DOES NOT EXTEND TO YOU, THE END-USER, ANY EXPRESS WARRANTY OR ANY IMPLIED WARRANTY OF MERCHANTABILITY, FITNESS FOR USE OR FITNESS FOR ANY PARTICULAR PURPOSE IN CONNECTION WITH THE HARDWARE, SOFTWARE, OR FIRMWARE EMBODIED IN OR USED IN CONJUNCTION WITH THIS PRODUCT. Sharp is not responsible for any damages or loss, either direct, incidental or consequential, which you, the end-user, may experience as a result of your purchase or use of the hardware, software or firmware embodied in or used in conjunction with this product. Your sole remedy in the event that you encounter any difficulties with the product is against the authorized dealer from which you purchased the product. In the event that this authorized dealer does not honor its warranty commitments, please contact the Point of Sale Division, ISG, Sharp Electronics Corporation, Sharp Plaza, P.O. Box 650, Mahwah, NJ 07430-2135 so that Sharp can try to help you to assure complete satisfaction of all the warranty rights to which you are entitled from the authorized dealer.

SHARP®

SHARP ELECTRONICS CORPORATION

Sharp Plaza, Mahwah, New Jersey 07430-2135

1-800-BE-SHARP

<http://www.sharp-usa.com>

SHARP CORPORATION