

ISO 9001
CERTIFIED

shindaiwa

**OWNER'S AND
OPERATOR'S MANUAL**

**SOUND PROOF DIESEL ENGINE
GENERATOR / WELDER**

DGW311DM

DGW311L

Water-cooled 4 Cycle Diesel Engine

Table of Contents	Page
1. Safety Guidelines	2
2. Specifications	5
3. Use	6
4. Parts	6
5. Equipment	7
5-1. ECO Welding (DGW311DM only)	7
5-2. Monitor Lamp	8
5-3. Earth Leakage Breaker	9
5-4. Slow-Down	11
6. Initialization and Pre-check	11
6-1. Checking Engine Oil	11
6-2. Checking Coolant/Water	12
6-3. Checking Fuel	13
6-4. Checking Fuel, Engine Oil, and water Leakage	14
6-5. Checking Battery	14
7. Operation	14
7-1. Initializing/Preparation	14
7-2. Stopping Generator/Welder	16
8. Welding Operation	16
8-1. Selection – Welding Cable	16
8-2. Polarity	17
8-3. Connection – Welding Cable	17
8-4. Duty Cycle	18
8-5. Welding	18
9. Generator Operation	19
9-1. Output Range	19
9-2. Output Limitation	21
9-3. Operation	22
10. Simultaneous Use of Welding and Generating	23
11. Checking and Maintenance	24
12. Long-term Storage	27
13. Troubleshooting	28
14. Engine Wiring Diagram	30
15. Generator Wiring Diagram	31

⚠ CAUTION : Do not operate the Generator/Welder, or any other appliance,
before you have read and understood the instructions for use.



Shindaiwa Kogyo Co.,Ltd.

Introduction

Thank you for purchasing Shindaiwa Sound Proof Diesel Engine Generator/Welder.

- This user manual was created to ensure the safe operation of this equipment. Therefore, the manufacturer of this equipment strongly recommends that the user follow the instructions herein, to avoid unnecessary accidents and repairs.
- Please operate this equipment after thoroughly reviewing and understanding the contents of this manual.
- Please attach this manual, if the equipment will be sub-leased.
- Please store this manual near the equipment for easy reference.

Following convention will be used throughout the manual to indicate the degree of cautions.

 Danger	<i>Can cause severe injuries or death.</i>
 Caution	<i>Can cause minor injuries or damage to the equipment or other properties.</i>
<Caution>	<i>Other types of caution</i>

- Even some of the items noted in  **Caution** may lead to severe injuries. Please read all items and follow all the safety guidelines.

1. Safety Guidelines

⚠ Danger : Suffocation from exhaust fume

- Exhaust fume from the engine contains many elements harmful to human. Do not operate this equipment in poorly ventilated area, such as inside a room or in a tunnel.

⚠ Danger : Electric Shock

- Do not touch the output terminals during operation.
- Do not insert metal objects (such as pin or wire) into plug-in receptacles.
- Do not touch wiring or electric parts inside the equipment during operation.
- Before connecting or disconnecting a load cable from output terminals, always turn the circuit breaker to OFF position.
- Before connecting or disconnecting a welding cable from output terminals, stop the engine, and remove the engine key.
- Before performing any equipment check or maintenance, stop the engine, and remove the engine key. A person performing the check or maintenance should always keep the key.

⚠ Danger : Burns

- Do not open the radiator cap while operating this equipment or immediately after stopping the equipment, to avoid sustaining burns from hot vapor.

⚠ Danger : Injuries

- Close all doors and place locks during operating this equipment, to avoid injuries by unintentionally touching cooling fan and fan belt.

⚠ Caution : Suffocation from exhaust fume

- Do not point the exhaust fume toward pedestrians or building.

⚠ Caution : Suffocation from welding fume

- Be sure to wear a fume proof mask in operation, because welding fume contains poisonous gas and dust. Pay attention to the airflow direction and sufficient ventilation also in order to prevent from inhaling the fume.

⚠ Caution : Injuries to eyes and skin

- Be sure to wear spark protection glass(es), long-sleeve shirts, gloves, etc. in order to protect eyes and skin from harmful spark in welding.
- Battery fluid contains diluted sulfuric acid. Avoid contact with eyes, skin or on clothing. If the acid comes in contact, especially with eyes, flush with a lot of water, and contact to your physician immediately.

⚠ Caution : Electric shock

- Do not flush water onto the equipment nor operate it in the rain.

⚠ Caution : Explosion

- When the liquid level is below the LOWER level, never use the equipment nor recharge the battery.
- Battery may emit some combustible gas, so keep it away from fire and sparks.

⚠ Caution : Fire

- The equipment uses Diesel fuel as a fuel. When refueling, always stop the engine and keep away from fire. Moreover, always wait until the engine cools down before refueling.
- Always wipe any drip of Diesel fuel or lubrication oil. Do not use this equipment when a leak is found. Repair the equipment before use.
- Temperature around muffler and exhaust can get extremely high. Keep any inflammable items (such as fuel, gas, paint, etc.) away from the equipment.
- Keep any inflammable items and easily burning items away from the place in welding, because welding splashes spatters.
- Always operate this equipment on flat surface and, at least 1 meter away from any objects (wall, box, etc.).
- Do not connect AC output to any indoor wiring.
- Always wait until the equipment cools down, before placing any covering materials for storage.

⚠ Caution : Burns

- Do not touch the engine and muffler during operation and immediately after stopping the equipment, for the temperature can reach extremely high.
- When checking engine oil or changing oil, always stop the engine, and wait until the engine cools down. If you open either the oil gauge or the oil filter cap during operation, hot oil may cause some injury.
- Be sure to wear leather gloves, apron, shoe covers, eye protection glass(es) (mask), safety shoes, safety cap, and long sleeve shirts, because welding splashes spatters.

⚠ Caution : Injuries

- When lifting the equipment, always use a lift hook. Do not lift a handle, for it may cause equipment to drop due to handle breaking off.
- Always place the equipment on a flat and stable surface, to keep the equipment from sliding. Be sure to lock the wheels for the wheeled models.
- When starting the engine, turn off the connected equipment and set the circuit breaker to OFF position.
- Do not move the equipment during operation.
- When performing equipment check and maintenance, always stop the engine.
- Do not operate the equipment, if the equipment is being modified or if the parts are removed.

■ Location of Warning labels

When the warning labels become unreadable or damaged, place new labels on the appropriate locations, as specified in the following figure.

When ordering the label, use the following part numbers.

Suffocation from exhaust fume	(No. 19402-00194)
Suffocation from welding fume	(No. 19402-00195)
Electric shock	(No. 19402-00192)
Electric shock	(No. 19402-00193)
Injuries	(No. 19402-00199)
Burns	(No. 19402-00201)
Burns	(No. 19402-00200)
Fire	(No. 19402-00166)

DGW311DM

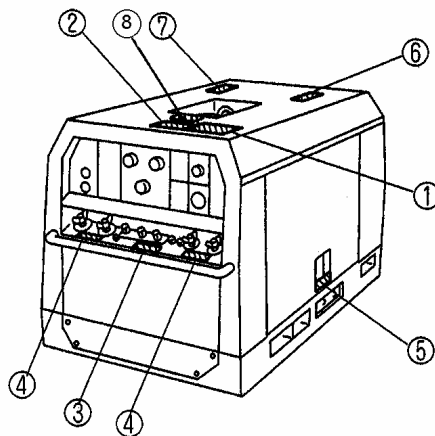

DGW311L [-(W)220B]

DGW311L [-(W)380A, -(W)400A, -(W)415A]

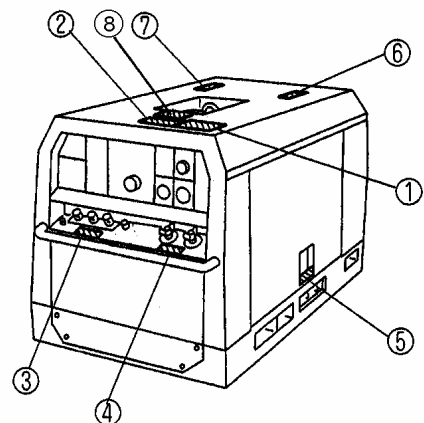
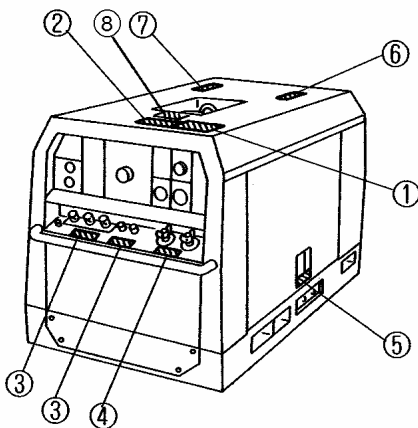

2. Specifications

Model		DGW311DM	DGW311L				
		-(W)220B	-(W)220B	-(W)380A	-(W)400A	-(W)415A	
Generating Method		Brushless, Rotating Field, Synchronous AC Generator					
Welding Generator	Rated Current (A)	280			260		
	Rated Voltage (V)	31.2			30.4		
	Duty Cycle (%)	50					
	Rated Speed (min ⁻¹)	3600			3000		
	No Load Voltage (V)	MAX 85					
	Output Change	Current Adj. Range (A)	ECO	30-160			
		Welding Rod (Φ)		2.0-4.0			
		Current Adj. Range (A)	Single	85-310	45-310	35-280	
		Welding Rod (Φ)		2.6-6.0	2.0-6.0	2.0-6.0	
		Current Adj. Range (A)	Dual	45-160			
Welding Rod (Φ)			2.0-4.0				
AC Generator	Phase	3-Phase/1-Phase					
	Rated Voltage (V)	220/110			380/220	400/230	415/240
	Frequency (Hz)	60			50		
	Rated Output (kVA)	3-Phase	10				
		1-Phase	6			8	
	Rated Speed (min ⁻¹)	3600			3000		
	Power Factor	3-Phase: 0.8 / 1-Phase: 1.0					
Rating	Continuous						
Engine	Model	Yanmar: 3TNE68-USW2					
	Type	Vertical, Water-cooled 4-Cycle Diesel Engine					
	Displacement (L)	0.784					
	Rated Output (kW(PS)/min ⁻¹)	15.1(20.5)/3600			12.9(17.5)/3000		
	Fuel	Diesel Fuel(ASTM No.2-D) or Equivalent					
	Lubricant Oil	API Class CD or Higher					
	Lubrication Oil Volume (L)	3.5					
	Cooling Water Volume (L)	3.1					
	Starting Method	Starter Motor					
Battery	46B24L						
Fuel Tank Capacity (L)	37						
Dimension	Length (mm)	1428 (Bonnet Length 1293)					
	Width (mm)	700					
	Height (mm)	760 (870 with wheels)					
Dry Weight (kg)	370 (380 with wheels)						

3. Use

- Arc Welding
- Power Source for Electric Tools and Home Appliances
- Power Source for Lighting

⚠ Caution : Damage to the equipment or other properties

- The equipment is designed for the above purposes only. Do not use it for the other purpose. When it will be used for the equipment with the microcomputer control or for the ultra-precision devices, the load may be malfunctioned.

4. Parts

DGW311DM

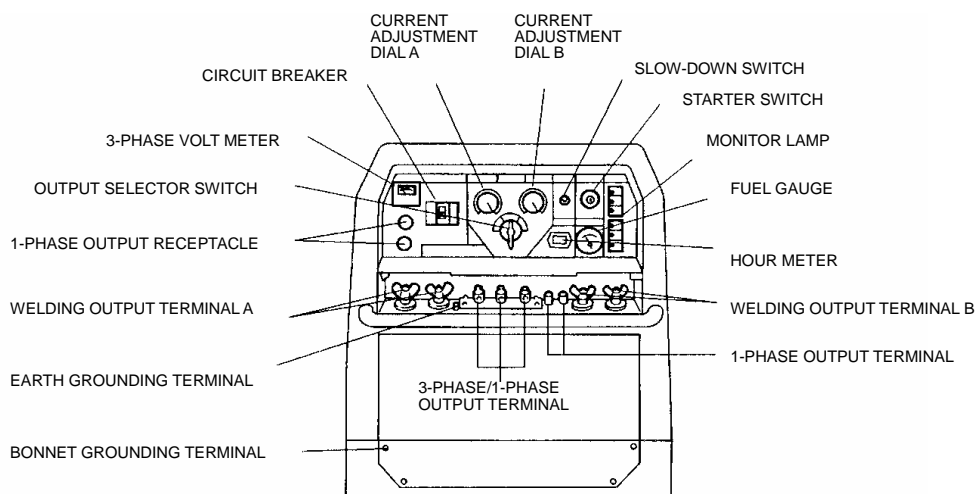

DGW311L [-(W)220B]

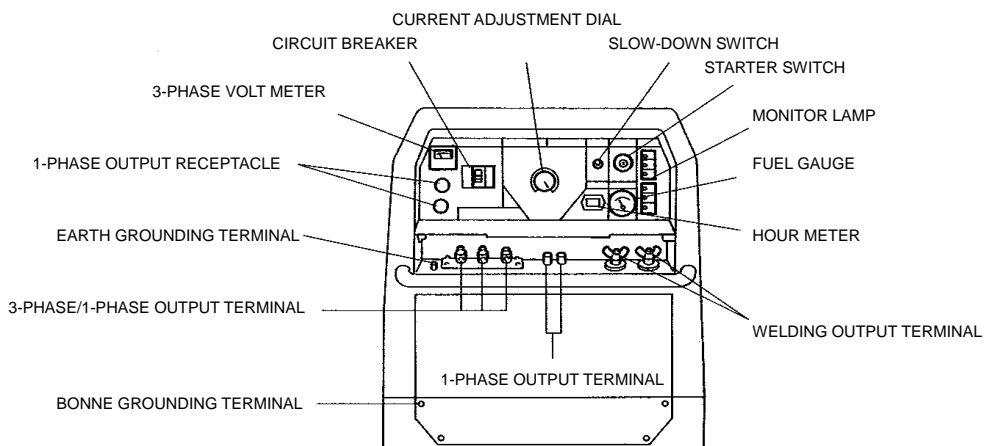

DGW311L [-(W)380A, -(W)400A, -(W)415A]

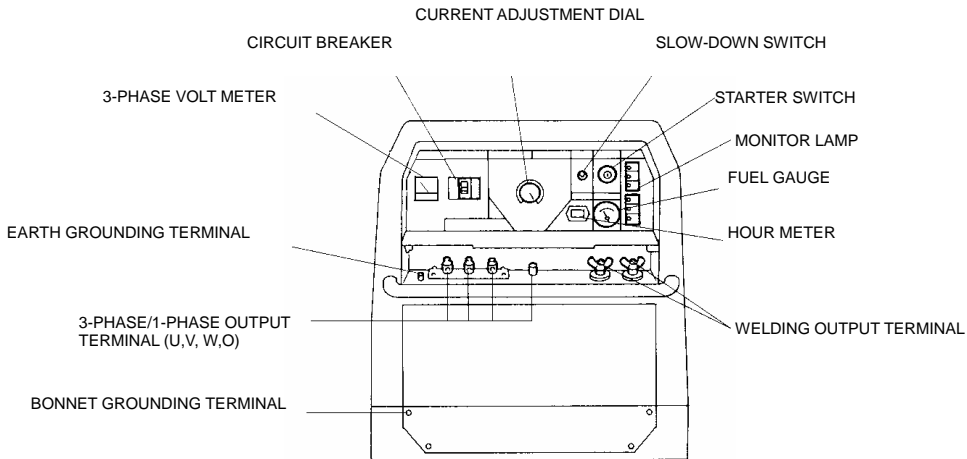

DGW311DM

DGW311L

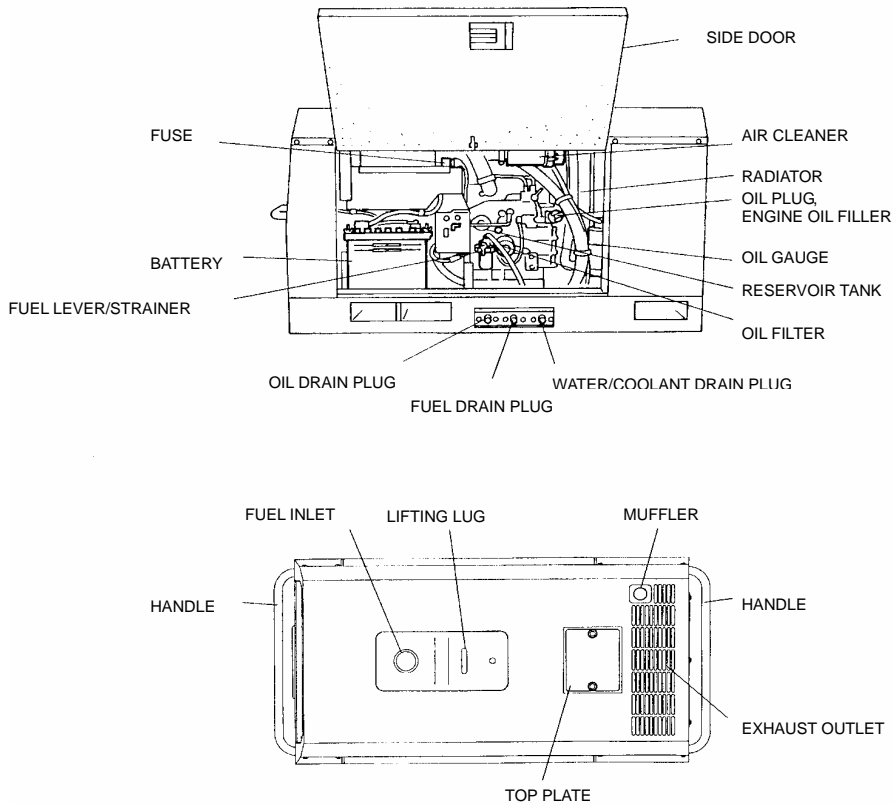

5. Equipment

5-1 ECO Welding (DGW311DM only)

The equipment is incorporated in ECO welding features that are aimed at performing the lower noise, the lower fuel consumption and the lower gas emission than conventional models. When you turn the selector switch to ECO, you will be able to weld with Max. 4.0mm welding rod at the Slow-Down speed.

<Caution>

- When welding is performed, do not turn the output selector switch, which causes the burnout of the switch.
- ECO is designed for welding only. The circuit breaker trips when ECO is used for AC power supply.

5-2 Monitor Lamp

The equipment is equipped with monitoring function of oil pressure, battery charge and water/coolant Temperature. When it is started by the starter switch from STOP to RUN under normal condition, Oil Pressure and Battery lamps will flash, and then the lamps will go off, immediately after the engine starts.

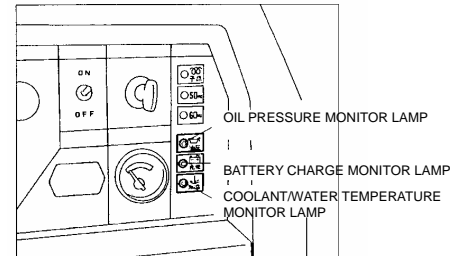

When abnormality is detected either in water temperature or in oil pressure, the corresponding monitor lamp will flash, and the automatic shutoff shall be engaged to the engine.

When the automatic shutoff is engaged, turn the starter switch to STOP position, and then restart the engine. In the event the automatic shutoff is engaged next time, check all parts of the corresponding alarm.

5-2.1 Oil Pressure Monitor Lamp

⚠ Danger : Injuries

- Close all doors and place locks during operating this equipment, to avoid injuries by unintentionally touching cooling fan and fan belt.

⚠ Caution : Burns

- Do not touch the engine and muffler during operation and immediately after stopping the equipment, for the temperature can reach extremely high.
- When checking engine oil, always stop the engine, and wait until the engine cools down. If you open either the oil gauge or the oil filter cap during operation, hot oil may cause some injury.

When the engine oil pressure drops during operation, the oil pressure monitor lamp will flash, and the automatic shutoff will be engaged.

When this occurs, check the engine oil level, and replenish to the maximum level if needed.

<Caution>

- The engine oil pressure monitor cannot detect the degradation of engine oil itself. Please check the engine oil periodically, and change if needed. (Refer to No. 11. Maintenance.)

5-2.2 Battery Charge Monitor Lamp

When the battery is unable to be charged during operation, the battery charge monitor lamp will flash and the automatic shutoff will be engaged. In the event it will happen, consult with the authorized distributor or our engineering section.

<Caution>

- The battery charge monitor cannot detect the degradation of battery life nor the battery fluid

level. Check the battery fluid level periodically. (Refer to No. 6-5 Checking Battery)

5-2.3 Coolant/Water Temperature Monitor Lamp

⚠ Danger : Injuries

- Close all doors and place locks during operating this equipment, to avoid injuries by unintentionally touching cooling fan and fan belt.

⚠ Danger : Burns

- Do not open the radiator cap while operating this equipment or immediately after stopping the equipment, to avoid sustaining burns from hot vapor.

⚠ Caution : Burns

- Do not touch the engine and muffler during operation and immediately after stopping the equipment, for the temperature can reach extremely high.

When the water temperature rises abnormally, the coolant/water temperature monitor lamp will flash, and the automatic shutoff will be engaged.

When this occurs, check the coolant/water reservoir tank, and replenish if needed. (Refer to No. 6-2 Checking coolant/water temperature.) If the water level is normal there may be a possibility of overloading and always use equipment within the rated amperage.

<Caution>

- Check the fuse next, after oil pressure, battery charge and water temperature will be found normal when you have checked them in the first place. If the fuse is burned out, consult with our authorized distributor or our engineering section, because there may be an abnormality of electric/electronic parts or wiring and repairing may be required.

5-3. Earth Leakage Breaker

⚠ Danger : Electric Shock

- All the grounding terminals must be grounded. If one of them is not grounded, human body may get a serious electric shock by leaked current.
- Even though all the terminals of the loads have been grounded to the earth, the earth grounding terminal and the outer bonnet (canopy) grounding terminal should be grounded to the earth.
- Grounding should be made after the engine is stopped.
- Whenever the earth leakage breaker has activated, you should always repair the leaking place first of all.

<Caution>

- The earth leakage breaker activates only for AC power supply.
- The circuit breaker trips to protect the loads, whenever AC power is used if the selector switch is in the ECO position. (DGW311DM only)

The equipment is provided with the earth leakage breaker to detect any leakage arisen due to such the troubles as insulation failure of the load while the generator is running and to cut off the circuit for protection against any accident such as electrical shock resulting from the trouble.

The specifications of the earth leakage breaker :

- Rated Sensitive Current: 30mA (or below) (Grounding resistance: 500 or below)
- Sensitive time: Within 0.1second

5-3.1 Grounding Work

The qualified electrician should perform the grounding work of the following 3 points (500 or below).

- The earth grounding terminal in the output terminals
- The Outer Bonnet (Canopy) of the generator
- The Outer Bonnet of the load

<Caution>

- In the event you cannot ground the generator to the earth, consult with the authorized distributor or our engineering section.

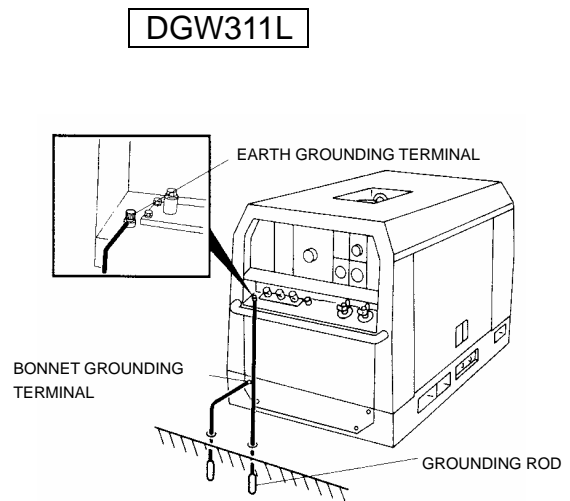
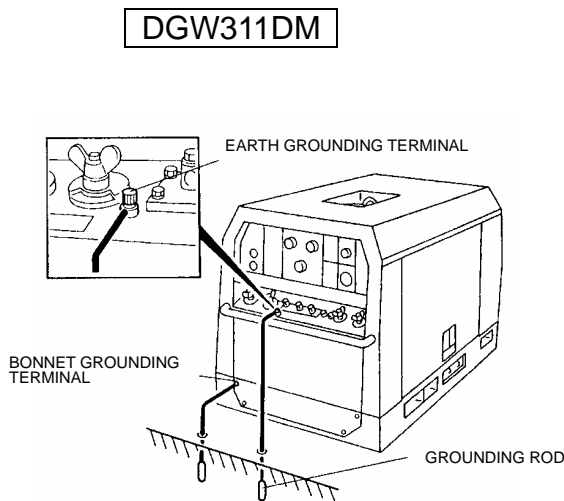

5-3.2 Operation Check

Before operating the generator, check always if the device can work.

Turn the starter switch from STOP to Run.

Turn (Push-up) the circuit breaker (lever) to ON position.

Push the test button. (When the button is pushed, the earth leakage indication lamp turns ON and the circuit breaker is positioned in the middle of ON and OFF positions, the device can work normal.)

Push the reset button. (The earth leakage indication lamp (red) turns OFF subsequently.)

Turn (push down) the circuit breaker (lever) to OFF position.

Restore the switch to STOP.

<Caution>

- In the event you cannot complete every step of the above procedure to the end, the device is out of order. Consult with our authorized distributor or our engineering section to repair.

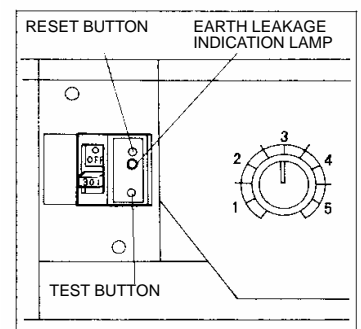

- When the engine is to start, there may be a case that the engine will not start unless the starter switch is restored to STOP once.

5-3.3 The Earth Leakage Breaker has activated

When the earth leakage breaker has activated, the earth leakage indication lamp turns ON and the breaker (lever) trips to the middle of ON and OFF positions. In the case, stop the engine promptly and find the leakage point to repair. After repairing leakage point(s), proceed with the following restoration steps.

Push the reset button or stop the engine.

Restore (push down) the breaker (lever) to OFF position.

By the above procedures, you can reset the breaker to ON position.

<Caution>

- When the breaker trips to the middle but the lamp does not turn RED simultaneously, the cause is Over-loaded or the output selector switch is positioned to ECO. Restore as per the procedures No. 9-3 Operation.

5-4 The Slow-Down Feature

The Slow-Down feature is to set the engine speed low automatically (in about 8 seconds) for the purpose of reducing noise and fuel consumption, whenever welding operation or electric supply is not performed.

In the case of using the Slow-Down feature, turn the Slow-Down switch to ON. The engine automatically moves to high speed, when welding operation or electric supply starts.

⚠ Caution : Damage to the equipment or other properties

- Turn always the Slow-Down switch to OFF, when the load is incorporated with a electro-magnetic switch.

<Caution>

- When the load of less than 0.5A is connected to use, the Slow-Down feature does not function sometimes. Therefore, turn the switch to OFF.
- When welding operation or electric supply is used intermittently, turn the switch to OFF.
- When the output selector switch is positioned to ECO, the engine does not turn to high speed. (DGW311DM only)

6. Initialization and Pre-check

⚠ Caution : Fire · Burns · Injuries

- When checking engine, always stop the engine, and keep away from fire. Wait until the engine cools down, before performing any checks.

6-1 Checking Engine Oil

When checking for engine oil, be sure to keep the equipment leveled, and insert the oil gauge all the way in.

Prior to starting the equipment, make sure to fill the engine oil to the HIGH level through the oil inlet.

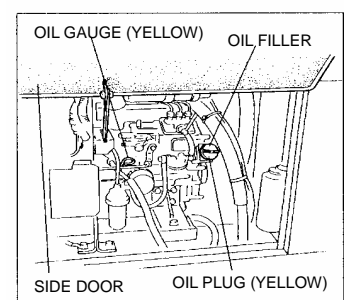

<Caution>

- If the equipment is not leveled, you cannot obtain accurate oil level.
- Do not overfill (over H line) the engine oil. The excessive volume of engine oil may damage the engine (inside the cylinders)

Selecting proper engine oil

Use the engine oil for Diesel engine in proper viscosity, in compliance with the ambient temperature.

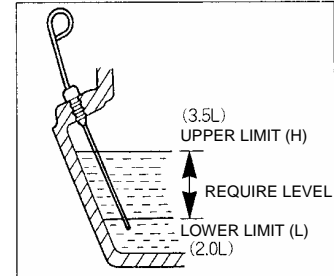

<Caution>

- Use the API class CD grade or higher.

Viscosity and Temperature

Temperature	Over +20	+10 - +20	-10 - +40
Viscosity	SAE30	SAE20	SAE10W/30

6-2 Checking Coolant/Water

⚠ Danger : Injuries

- Close all doors and place locks during operating this equipment, to avoid injuries by unintentionally touching cooling fan and fan belt.

⚠ Danger : Burns

- Do not open the radiator cap while operating this equipment or immediately after stopping the equipment, to avoid sustaining burns from hot vapor.

⚠ Caution : Burns

- Do not touch the engine and muffler during operation and immediately after stopping the equipment, for the temperature can reach extremely high.

Check to see if the coolant/water level is between FULL and LOW levels in the reservoir tank. If the coolant/water is below the LOW level, fill the tank and the radiator accordingly.

6-2.1 Filling to the Reservoir Tank

Take out the reservoir tank to remove the cap.

Fill up the reservoir tank to the FULL level.

Install the cap back and tighten, and reinstall the tank to the equipment.

6-2.2 Filling to the Radiator

Remove the top plate.

Remove the radiator cap.

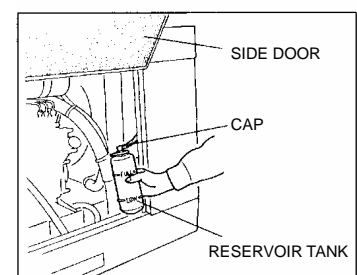

Fill up the radiator up to the top.
 Install the cap back and tighten.
 Reinstall the top plate.

<Caution>

- Use soft water, such as tap water.
- If the ambient temperature is near freezing, use Long Life Coolant (LLC) (30% mixture LLC is filled when shipped from factory).
- Mixture ratio of the coolant should be between 30 to 45%, depending on the outside temperature.
- Use the same LLC in identical mixture ratio to the reservoir tank.
- Replace LLC at every year or 1000 hours.

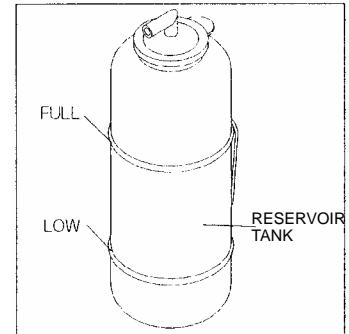
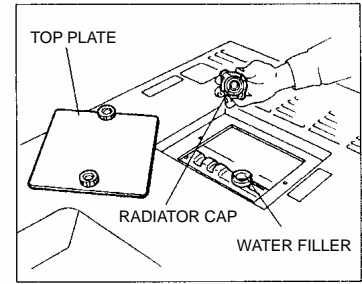

Mixture Ratio (for reference only):

Lowest Ambient Temperature	-15	-20	-30
Mixture Ratio	30%	35%	45%

6-3 Checking Fuel

⚠ Caution : Fire

- Always wipe any drip of fuel. Do not use this equipment when a leak is found. Repair the equipment before use.

Check for the fuel level in the tank. Add if necessary.

<Caution>

- Use Diesel fuel, ASTM D975 No.2-D in the event ambient temperature reaches down to -5 .
- The engine is designed to use either No.1-D or No.2-D Diesel fuel. However, for better economy, use No. 2-D Diesel Fuel whenever possible. At the temperature less than -7 (20F), No.2-D fuel may pose operating problems (see “Cold Weather Operation” which follows). At colder temperatures, use No.1-D fuel (if available) or use a “winterized” No.2-D (a blend of No.1-D and No.2-D).

This blended fuel is usually called No.2-D also, but can be used in colder temperatures than No.2-D fuel, which has not, been “winterized”. Check with the services stations operator to be sure you can get the properly blended fuel.

- Always use the Diesel fuel strainer.
- Fill the fuel tank slightly less than the FULL tank.

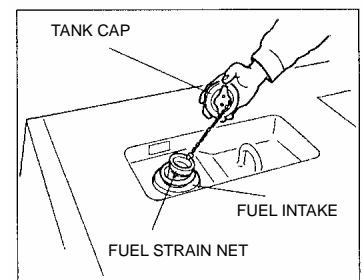

6-4 Checking Fuel, Engine Oil and Water Leakage

⚠ Caution : Fire

- Always wipe any drip of Diesel fuel or oil. Do not use this equipment when a leak is found. Repair the equipment before use.

Be sure to check for any fuel leak at the hose connection, and oil and coolant/water by opening side doors. When checking for any fuel leak, open a fuel lever and be sure to close the fuel lever after checking.

6-5 Checking Battery

⚠ Caution : Injuries to eyes and skin

- Battery fluid contains diluted sulfuric acid. Avoid contact with eyes, skin or clothing. If the acid comes in contact, especially with eyes, flush with a lot of water, and contact your physician immediately.

⚠ Caution : Explosion

- When the liquid level is below the LOWER level, never use the equipment nor recharge the battery.
- Battery may emit some combustible gas, so keep it away from fire and sparks.

Check the fluid level. If the level is near or lower than the LOWER level, add distilled water until the fluid level reaches the UPPER level.

Make sure that the battery cables are firmly secured to the posts. Tighten the clamps if necessary.

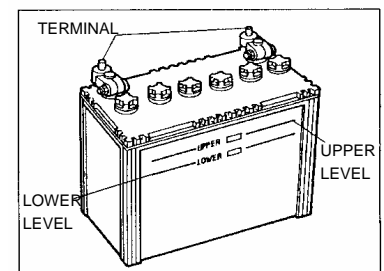

<Caution>

- Check the hydrometer of the battery fluid. If it falls below 1.23, the battery requires recharging. Please consult with our authorized distributor or our engineering section.

■ Replacing battery

Remove the clamp and cable from negative (-) post in the battery. (Remove always negative side first)

Remove the hold-down clamp from the battery.

Remove the clamp and cable from positive (+) post in the battery.

Remove the battery from the seat.

Reinstall a new battery in the reverse order. (Install always the cable to the positive (+) post in the new battery first.)

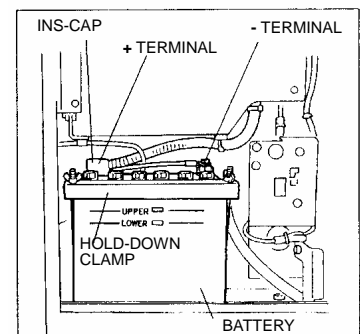

<Caution>

- Use the following battery.
46B24L

7. Operation

7-1 Initializing/Preparation

⚠ Danger : Suffocation from exhaust fume

- Exhaust fume from the engine contains many elements harmful to human. Do not operate this equipment in poorly ventilated area, such as inside a room or in a tunnel.

⚠ Caution : Suffocation from exhaust fume

- Do not point the exhaust fume toward pedestrians or building.

⚠ Caution : Fire

- Temperature around muffler and exhaust can get extremely high. Keep any inflammable items (such as fuel, gas, paint, etc.) away from the equipment.
- Always operate this equipment on flat surface and, at least 1 meter away from any objects (wall, box, etc.)

⚠ Caution : Injuries

- Always place the equipment on flat and stable surface, to keep the equipment from sliding. Be sure to lock the wheels for the wheeled models.
- When starting the engine, turn off the connected equipment and set the circuit breaker to OFF position.

Turn the circuit breaker to OFF position.

Turn the fuel lever to OPEN.

Turn the Slow-Down switch to ON.

When the temperature is below 5 , turn the starter switch to PREHEAT. The preheating lamp flashes 15 seconds. The lamp comes off when the PREHEAT finishes.

Turn the starter switch to START to start the engine by the starter motor.

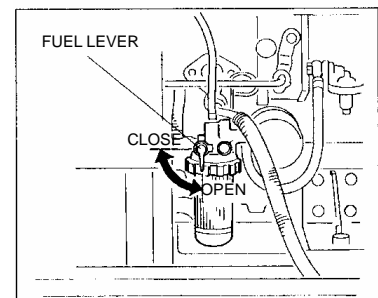

<Caution>

- Do not drive the starter motor for more than 15 seconds successively.
 - If you need to restart, wait for 30 seconds or more before retry.
- Release the starter switch, as soon as the engine is started.

<Caution>

- Once the engine is started, do not turn the starter switch to START.
- Make sure the frequency to the monitor on the control panel.
- Keep the engine idle for about 5 minutes.

DGW311DM

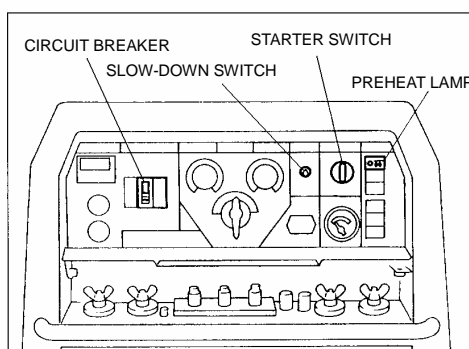

DGW311L

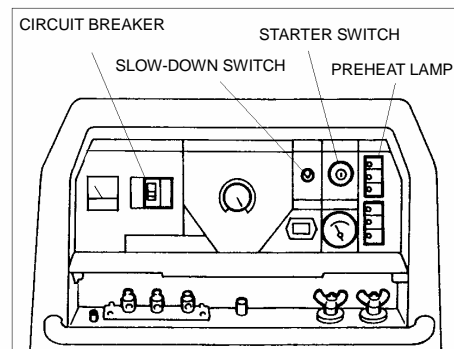

■ Restart after stopping due to fuel shortage

This equipment is equipped with automatic air vacuuming feature. Therefore, even though the engine stops due to running out of fuel, you can restart the engine easily by the following steps.

Turn the starter switch to STOP.

Fill the fuel.

Turn the Slow-Down switch to ON.

Turn the starter switch to RUN.

Turn the starter switch to START and drive the starter motor.

<Caution>

- Do not drive the starter motor for more than 15 seconds successively.
- If you need restart, wait for 30 seconds or more before retry.

Release the starter switch, as soon as the engine started.

<Caution>

- Once the engine is started, do not turn the starter switch to START.

Wait for about 1 minute to vacuum the air out.

(The engine speed becomes stable when the air is extracted.)

<Caution>

- Keep the Slow-Down switch ON until the air is completely extracted out (until the engine speed becomes stable), otherwise the engine may disorder.

7-2 Stopping Generator/Welder

Turn (Push down) the breaker to OFF.

Turn the Slow-Down switch to ON.

Keep the engine idle (cooling down) for about 5 minutes.

Turn the starter switch to STOP.

After the engine stops, turn the fuel lever to CLOSE.

<Caution>

- When the engine does not stop in spite of turning the starter switch to STOP, turn the fuel lever to CLOSE, then the engine will stop in a few minutes.

In this case, consult with our authorized distributor or our engineering section and ask to repair.

8. Welding Operation

8-1 Selection – Welding Cable

Select the cable with proper gauge, based on the allowable amperage and distance per the table shown below.

The welding capacity is reduced if the small gauge cable is used.

<Caution>

- Welding cables should be used unstrained.
- When the welding cables are used in swirl, the welding capacity is reduced.

Size of Cable (Unit: mm²)

Welding Current	Return Length	20m	30m	40m	60m	80m	100m
300A		30	38	50	80	100	125
250A		22	30	38	60	80	100
200A		22	30	30	50	60	80
150A		22	22	22	38	50	60
100A		22	22	22	30	30	38

8-2 Polarity

There are two kinds of welding output terminals, 「+」 and 「-」.

Select the polarity according to the operation, referring to the table below.

<Caution>

- Follow the instruction of the welding rods, the polarity of which is specified.

	Application	Connection
Normal Polarity	General Welding, such as construction	Plus to the Earth (Material) Minus to holder (Rod)
Reverse Polarity	Thin Plate, Build up Welding, Stainless Steel	Plus to holder (Rod) Minus to the Earth (Material)

8-3 Connection – Welding Cable

⚠ Danger : Electric Shock

- Before connecting or disconnecting a welding cable from welding output terminals, stop the engine, and remove the engine key. A person performing should always keep the key.

Stop the engine.

Connect a welding cable to a crimping terminal and a welding rod holder, and connect the other cable to a crimping terminal and a material holder.

Connect the welding cables to the output terminals.

In terms of DGW311DM, connect cables to the welding output terminals, referring to the table below.

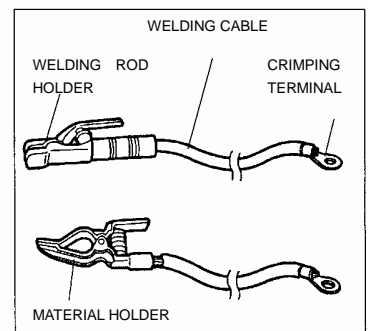

ECO (Single)	Single	Dual
Welding Rod 2.0 – 4.0	Welding Rod 2.6 – 6.0	Welding Rod 2.0 – 4.0
Welding Output Terminal A	Welding Output Terminal A	Welding Output Terminal A and Welding Output Terminal B

Close the output terminal cover, after finishing connections, and fix the cover with bolts.

<Caution>

- Be sure to crimp a crimping terminal to a cable and connect the cable to welding output ter-

minal. Otherwise, welding output terminals may burn out by the heat caused by insufficient connections.

- Do not use a cable without a crimping terminal. If you use the cable, the insulation is peeled off partly, to bind to an output terminal, the output terminal may burn out by the heat caused by insufficient connections and also a bare part of the cable may touch the bonnet to short-circuit.

8-4 Duty Cycle

Duty cycle means the welding time ratio for 10 minutes. This equipment is the rated duty cycle is 50%, namely, the welding time is 5 minutes or less. Be sure to take 5 minutes recess after 5 minutes welding.

<Caution>

- The equipment may be damaged due to overheat, if welding more than 5 minutes successively or short time recess after the welding.

8-5 Welding

⚠ Caution : Suffocation from welding fume

- Be sure to wear a fume proof mask in operation, because welding fume contains poisonous gas and dust. Pay attention to the airflow direction and sufficient ventilation also in order to prevent from inhaling the fume.

⚠ Caution : Injuries to eyes and skin

- Be sure to wear spark protection glass(es)(Refer to the table below), long-sleeve shirts, gloves, etc. in order to protect eyes and skin from harmful spark in welding.

Standard for Spark Protection Glass (Japan Industrial Standard)

Light Shielding Degree No.	7	8	9	10	11	12	13
Welding Current (A)	30-75		76-200			201-400	

⚠ Caution : Fire

- Keep any inflammable items and easily burning items away from the place in welding, because welding splashes spatters.

⚠ Caution : Burns

- Be sure to wear leather gloves, apron, shoe covers, eye protection glass(es)(mask), safety shoes, safety cap and long sleeve shirts, because welding splashes spatters.

<Caution>

- Never turn the output selector switch during welding, because it causes burnout of the switch. (DGW311DM only)

8-5.1 DGW311DM

The equipment can be welding by 2 persons simultaneously.

Each person can adjust the welding current individually.

The current adjustable range by the current adjustable dial depends on the position each of the

welding output selector switch (『ECO』 , 『Single』 and 『Dual』).

Welding Current Adjustable Range

	Selector Position	Current Adjustable Range	Welding Rod
Single	ECO	30-160A	2.0-4.0
	Single Use	85-310A	2.6-6.0
Dual	Dual Use	45-160A	2.0-4.0

After the engine is started (Refer to No. 7.1 Initializing/Preparation), operate as per the procedures in the following table.

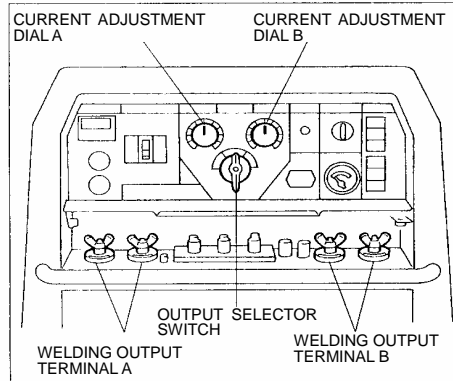

Welding Operation Procedure

Procedure	Operation	ECO (Single)	Single Welding	Dual Welding
		Welding Rod 2.0- 4.0	Welding Rod 2.6- 6.0	Welding Rod 2.0- 4.0
	Selector	『ECO』	『SINGLE』	『DUAL』
	Current Adjustment	Current Adjust. Dial A	Current Adjust. Dial A	Current Adjust. Dial A + B

8-5.2 DGW311L

Start the engine. (Refer to No. 7.1 Initializing/Preparation)

Adjust the current by the current adjustment dial.

Welding Current Adjustable Range

Current Adjustable Range		Welding Rod
50Hz	60Hz	
-(W)380A, -(W)400A, -(W)415A	-(W)220B	2.0- 6.0
35-280A	45-310A	

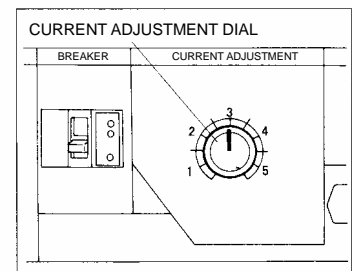

9. Generator Operation

9-1 Output Range

9-1.1 DGW311DM-(W)220B, DGW311L-(W)220B

9-1.1.1 3-Phase 220V Output – Terminals

Maximum output from the terminals (U, V, W) is 10kVA.

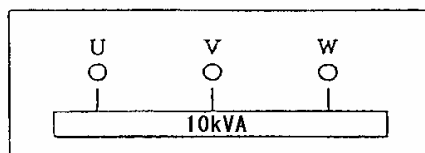

9-1.1.2 1-Phase 220V Output – Terminals (using the terminals only)

1-Phase 220V Output is available, using the 3-phase output terminals. Maximum output available for the one set of the terminals is 6kVA but the total output for the 3 sets is 8kVA, which please note.

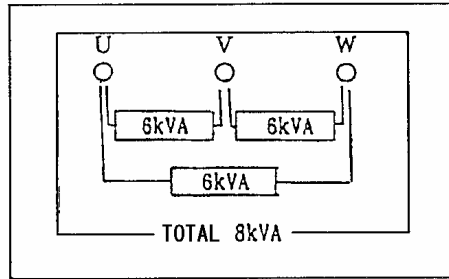

9-1.1.3 1-Phase 110V Output – Receptacles & Terminals

1-Phase 110V Output is available through 2 receptacle sets and one terminal set. Maximum output per one receptacle is 1.5kVA and one terminal set is 3kVA. The total output for the receptacles and the terminal set is 6kVA.

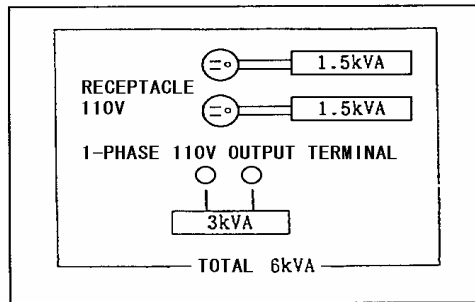

9-1.2 DGW311L-(W)380A, DGW311L-(W)400A, DGW311L-(W)415A

9-1.2.1 3-Phase Output – Terminals

Maximum output from the terminals (U, V, W) is 10kVA.

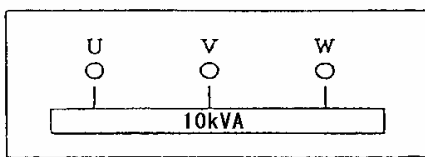

	DGW311L		
	-(W)380A	-(W)400A	-(W)415A
Output voltage	380V	400V	415V

9-1.2.2 1-Phase Output – Terminals

1-Phase Output is available, using the 3-Phase output terminals. Maximum output available for the one set of the terminals is 6kVA but the total output for the 3 sets is 8kVA, which please note.

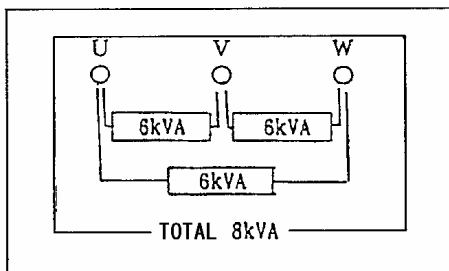

	DGW311L		
	-(W)380A	-(W)400A	-(W)415A
Output voltage	380V	400V	415V

9-1.2.3 1-Phase Output – Terminals

1-Phase Output is available, using the 3-Phase output terminals and the other terminal (O). Maximum output available for the one set of terminals is 3kVA but the total output for 3 sets is 8kVA, which please note.

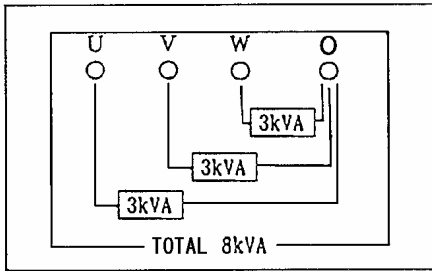

	DGW311L		
	-(W)380A	-(W)400A	-(W)415A
Output voltage	220V	230V	240V

<Caution>

- When using 1-Phase output, connect the loads evenly to each terminal set as much as possible.

9-2 Output Limitation

Please refer to the following table, because electric tools and home appliances cannot be judged only by the rated output or the power consumption due to the efficiency and characteristic of the components.

DGW311DM-(W)220B, DGW311L-(W)220B :

Applicable Load (For reference purpose only)

(60Hz)

Loads	Capacity (kW)					
	1-Phase 110V			1-Phase 220V		3-Phase 220V
	Receptacle 1 unit	Terminal 1 set	Receptacle & Terminal Total	Terminal 1 set	Terminal 3 sets Total	Terminal
Electric Bulb, Heater, etc.	1.5	3.0	6.0	6.0	8.0	-
Electric Tools (Series Motor), etc.	0.7	1.5	3.0	3.0	4.0	-
Mercury Bulb (High Power Factor Type)	0.6	1.2	2.4	2.4	3.2	-
Submersible Pump, Compressor, etc. (Induction Motor)	0.6	1.2	2.4	2.4	3.2	4.0

DGW311L-(W)380A, DGW311L-(W)400A, DGW311L-(W)415A :

Applicable Load (For reference purpose only)

(50Hz)

Loads	Capacity (kW)				
	1-Phase (O & U, V, W)		1-Phase (U, V, W)		3-Phase (U, V, W)
	Terminal 1 set	Terminal 3 sets Total	Terminal 1 set	Terminal 3 sets Total	Terminal
Electric Bulb, Heater, etc.	3.0	6.0	6.0	8.0	-
Electric Tools (Series Motor), etc.	1.5	3.0	3.0	4.0	-
Mercury Bulb (High Power Factor Type)	1.2	2.4	2.4	3.2	-
Submersible Pump, Com- pressor, etc. (Induction Mo- tor)	1.2	2.4	2.4	3.2	4.0

Series Motor: Motor with brush

Induction Motor: Brushless Motor

The value described is 『OUTPUT』 for Induction Motor loads and 『POWER CONSUMPTION』 for the other equipment.

<Caution>

- Be sure to use the frequency designated in the equipment incorporated in mercury lamp or induction motor.
- The load incorporated in motor may require bigger power than the rated power consumption. Therefore, consult with our authorized distributor or our engineering section to clarify.
- When connecting 2 or more sets to use, start the load one by one, not to start them simultaneously.
- When switching a Mercury bulb ON again, wait for 15 minutes (about) until it cools down.
- A Mercury bulb may flicker sometimes.

9-3 Operation

Danger : Electric Shock

- Before connecting or disconnecting a load cable from output terminals, always turn a circuit breaker to 『OFF』 position.
- All the grounding terminals must be grounded. If one of them is not grounded, human body may get a serious electric shock by leaked current. (Refer to 『5-3 Earth Leakage Breaker』)
- Grounding should be made after the engine is stopped.
- Whenever the earth leakage breaker activates, you should repair the leaking place first of all.

Caution : Injuries

- Be sure to connect to output terminals or insert a plug to a receptacle, after confirming that all the switches in the loads are positioned to 『OFF』.

⚠ Caution : Damage to the equipment or other properties

- In the event using the equipment to computers, microcomputers incorporated loads and precision equipment, there is a possibility for them to be mal-functioned or broken down.

<Caution>

- Be sure to use the power cord with crimping terminal to connect to output terminals.
- Volt meter reads the 3-Phase figures, even if the circuit breaker is positioned to 「OFF」, when the engine is driving.

After the engine starts (Refer to 「7-1 Initializing/Preparation」), operate the equipment as per the following procedures.

Turn off the power switch in the load, and then turn the circuit breaker to 「OFF」.

Connect the load to the output terminals or receptacles.

Close the output terminal cover, after finishing connections and fix the cover with bolts.

Turn the circuit breaker to 「ON」.

When finishing the load operation, always turn the circuit breaker to 「OFF」.

■ The Circuit Breaker

⚠ Caution : Injuries

- Be sure to turn off the power switch in the load when turning the circuit breaker to 「ON」, when the circuit breaker has activated.

When the electric supply exceeds the rated output (overload), the circuit breaker activates to trip off in order to shut off the circuit. When the load in operation stops, check the breaker. When the circuit breaker is positioned intermediary 「ON」 and 「OFF」, check if the earth leakage indication lamp turns ON or not. In the case the lamp turning ON, refer to 「5-3 Earth Leakage Breaker」. In the case the lamp NOT turning ON, follow the next procedures to restore the circuit breaker.

Turn off all the power switches in the loads.

Turn (Push) down the circuit breaker to 「OFF」 once and then turn (push) up the circuit breaker to 「ON」.

<Caution>

- Take care for overload, referring to 「9-2 Output Limitation」.
- When the output selector switch is positioned to ECO and AC power is used, the circuit breaker trips off to shut down the circuit. Stop using AC power and follow the above procedures to restore the circuit breaker. (DGW311DM only)

10. Simultaneous Use of Welding and Generating

The circuit breaker reacts on the AC power supply circuit only. In the simultaneous use of welding and generating, there sometimes happens overload to the engine.

Refer to the following table and limit the AC power use.

DGW311DM-(W)220B, DGW311L-(W)220B :

Limitation of AC Power Supply in the simultaneous use of welding and generating (60Hz)

Welding Output	AC Power Output	
	3-Phase Power use only	1-Phase Power Use only
Welding Rod/Current		
2.0mm/50A or below	9.5kVA or below	7.6kVA or below
2.6mm/80A	8.6kVA or below	6.8kVA or below
3.2mm/120A	7.2kVA or below	5.7kVA or below
4.0mm (2.0mmx2)/170A	5.2kVA or below	4.1kVA or below
5.0mm (2.6mmx2)/220A	3.0kVA or below	2.4kVA or below
6.0mm (3.2mmx2)/280A	0kVA or below	0kVA or below

() indicates 2-Persons Dual Use. (DGW311DM only)

<Caution>

- The simultaneous use of ECO welding and AC power is not available. (DGW311DM only)

DGW311L-(W)380A, DGW311L-(W)400A, DGW311L-(W)415A :

Limitation of AC Power Supply in the simultaneous use of welding and generating (50Hz)

Welding Output	AC Power Output	
	3-Phase Power use only	1-Phase Power Use only
Welding Rod/Current		
2.0mm/50A or below	8.5kVA or below	6.8kVA or below
2.6mm/80A	7.6kVA or below	6.0kVA or below
3.2mm/120A	6.2kVA or below	4.9kVA or below
4.0mm/170A	4.2kVA or below	3.3kVA or below
5.0mm/220A	2.0kVA or below	1.6kVA or below
6.0mm/260A	0kVA or below	0kVA or below

11. Checking and Maintenance

Danger : Electric Shock • Injuries

- Before performing any equipment check or maintenance, stop the engine, and remove engine key. A person performing the maintenance should always keep the key.

Caution : Fire • Burns

- When checking the engine, always stop the engine, and keep away from fire. Wait until the engine cools down, before performing any checks.

To optimize the use of this equipment, we recommend the periodical equipment checks and maintenance based on the following matrix.

<Caution>

- The authorized technicians should perform all checking and maintenance work, except for the pre-startup checks.
- Request for the maintenance item with  mark to the authorized distributor or our engineering section.
- This table only covers the simple checks and maintenance for the engine. For more detailed guide, please refer to the User's Manual for the engine.
- Always use our genuine replacement parts.

Use the hour meter as a guide for the operating time.

Checking Items		Startup Check	Checking Time				
			At 50hrs	Every 200hrs	Every 400hrs	Every 1000 hrs	Every 2000 hrs
1	Check and Supply Fuel						
2	Check and Supply Engine Oil						
3	Engine Oil Change		1 st	2 nd or after			
4	Oil Filter Change		1 st	2 nd or after			
5	Check/Add Water/Coolant						
6	Water/Coolant Change					or one year	
7	Clean/Change Fuel Filter			(Clean)	(change)		
8	Drain Water from Fuel Tank						
9	Check Leakage Fuel • Oil • Water						
10	Check/Add Water Battery						
11	Clean/Change Air Cleaner Element			(Clean)	(change)		
12	Adjust Tension V-Belt		1 st	2 nd or after			
13	Clean Radiator Fin						
14	Change Hose Fuel • Radiator Change Vibration-Absorbing Rubber						or 2 years
15	Adjust Engine Valve Clearance					(Adjust)	(Adjust)
16	Check/Adjust Injection Nozzle						
17	Check/Adjust Injection Pump						

11.1 Oil Change

First Time	50 hour mark
2 nd or after	Every 200 hours

Remove the oil plug.

Loosen the oil drain plug and allow the oil to drain fully.

Reinstall the oil drain plug.

Checking the oil level by the oil level gauge, add oil into the oil filler to fill up to the max level. (3.5 liter Max)

Reinstall the oil plug hand tight.

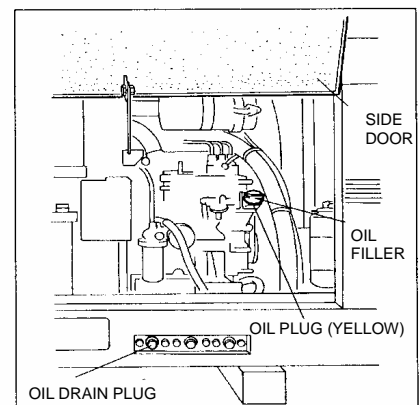

<Caution>

- Refer to 『6-1 Checking Engine Oil』 to select engine oil.

11.2 Oil Filter Change

First Time	50 hour mark
2 nd or after	Every 200 hours

Drain the engine oil fully, as describe in 『11-1 Oil Change』 .

Loosen and remove the oil filter, using an oil filter wrench.

Smear a little engine oil on the rubber gasket of a new filter.

Screw the new filter into place and tighten it by hand until the gasket contact the seat. Then, give it additional 『1.1/4 Turn』 to seat the filter, using an filter wrench.

Supply oil and install the filler cap.

<Caution>

- If an oil filter wrench is not available, contact our authorized distributor or our engineering section.
- Oil Filter Part No.: 119305-35151 (Yanmar)

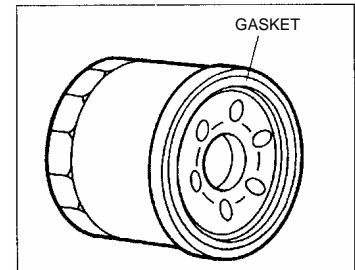
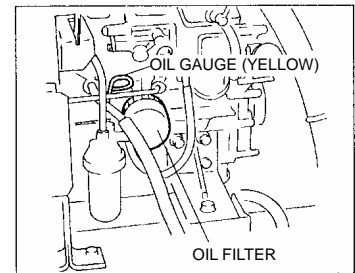

11.3 Cleaning/Changing Air Filter Element

Clean	Every 200 hours
Replace	Every 400 hours

Unfasten clips in the cleaner cap and remove the air cleaner cap.

Unscrew the wing bolt and remove the air filter element.

Clean or replace the air filter element, and reinstall it in reverse order.

<Caution>

- Clean more frequently, if used in dusty environment.
- Air Filter Element Part No. 121465-12510 (Yanmar)

■ How to clean air filter element

<If the element has dried contaminants>

It may be cleaned by blowing compressed air from the inside.

<If the element has carbon or oil>

It should be replaced to a new one.

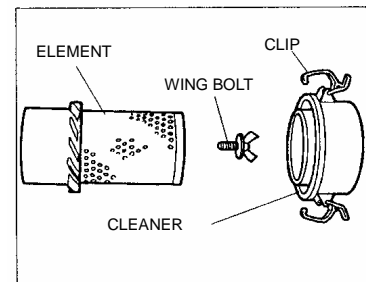
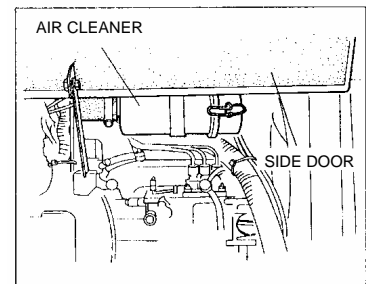

11.4 Cleaning/Changing Fuel Filter

Clean	Every 200 hours
Replace	Every 400 hours

Turn the fuel line valve lever to 『CLOSE』.

Unscrew the retaining ring by turning counterclockwise, and remove the cup and fuel filter element.

Discard any dust or water inside the cup, and clean the filter element by blowing compressed air. (or replace, if necessary) (When you replace the filter element, be sure to replace a o-ring

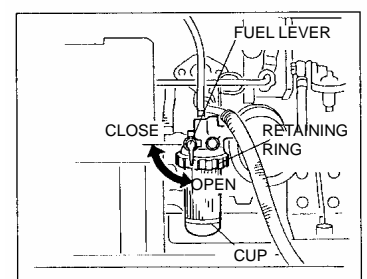

as well)

Reassemble it back.

<Caution>

- Be sure to check for any contaminants on the packing, whenever reinstalling the cup.
- Turn the fuel line valve lever 『OPEN』 after assembling, and check for any leak. Confirming no leak, turn the fuel line valve 『CLOSE』.
- Fuel Element Part No.: 124550-55700 (Yanmar)

11.5 Draining Water from Fuel Tank

Drain Water	Every 200 hours
-------------	-----------------

Unscrew the fuel drain plug.

Reinstall the drain plug, after draining the water entirely.

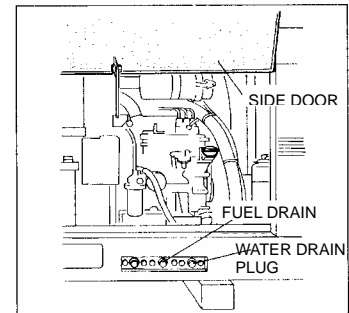

11.6 Changing Coolant/Water

Replace	Every 1 year or 1000 hours
---------	----------------------------

Remove the top plate.

Remove the radiator cap.

Loosen the water drain plug.

After draining all the water, reinstall the water drain plug.

Remove the reservoir tank and replace all the water.

Install the reservoir tank back, and fill the radiator with coolant/water up to radiator filler neck. (Total coolant/water Capacity is 3.1 liter.)

Reinstall the radiator cap.

Install the top plate back.

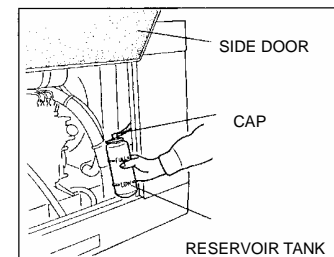
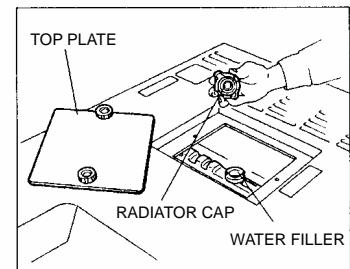

12. Long - Term Storage

⚠ Danger : Electric Shock

- Before performing any equipment check or maintenance, stop the engine, and remove the engine key. A person performing the maintenance should always keep the key.

⚠ Caution: Injuries

- Before performing any equipment check or maintenance, stop the engine, and remove the engine key. A person performing the maintenance should always keep the key.

⚠ Caution : Fire • Burns

- When checking engine, always stop the engine, and keep away from fire.
- Temperature around muffler and exhaust can get extremely high. Wait until the engine cools down, before performing any checks.

If the generator/welder will not be used for more than two months, perform the following maintenance and storage procedures.

Remove battery.

Change engine oil.

Drain fuel from fuel tank and fuel filter.

Clean all parts, cover the generator/welder, and keep it in the storage, away from dust and humidity.

<Caution>

- Recharge the removed battery once a month.

13. Troubleshooting

Danger : Electric Shock

- Do not operate the equipment, if the equipment or you are wet.
- Before performing any equipment check or maintenance, stop the engine.

Caution : Injuries

- When performing equipment check and maintenance, always stop the engine.

Caution : Fire • Burns

- When checking engine, always stop the engine, and keep away from fire.
- Temperature around engine, muffler and exhaust can get extremely high. Wait until the engine cools down, before performing any checks.

Follow the guideline below, when performing any troubleshooting. If you cannot resolve the problems by this troubleshooting guide, contact the authorized distributor or our engineering section to request the repair.

Symptoms	Possible Cause	Corrective Actions
Starter motor does not start	1. Weak Battery 2. Dead Battery	1. Recharge Battery 2. Replace Battery
Engine does not start	1. Fuel lever to CLOSE 2. Insufficient Fuel 3. Water or contaminants in fuel	1. Fuel lever to OPEN 2. Replenish fuel 3. Drain water or clean fuel tank, fuel filter, and water sediments
Engine starts, but stalls immediately	1. Insufficient oil 2. Insufficient coolant/water	1. Replenish oil 2. Replenish coolant/water
Welding Arc is weak	1. Output selector switch is to 『ECO』 or 『DUAL』 2. Wrong current adjustment dial setting 3. Poor contacts of cables 4. Improper Cable Diameter 5. Insufficient connection to material 6. Dual Use 7. Engine output is down	1. Turn to 『SINGLE』 or 『RATED SPEED』 2. Turn the dial clockwise 3. Connect securely 4. Change cables according to 『Selection – Welding Cable』 5. Connect securely 6. Stop using AC Power 7. Keep 50% duty cycle
Excessive Welding Arc	1. Output selector switch is to 『SINGLE』 or 『RATED OUTPUT』 2. Wrong current adjustment dial position	1. Turn to 『ECO』 or 『DUAL』 2. Turn the dial counterclockwise

No AC output	<ol style="list-style-type: none"> 1. Circuit breaker is to 『OFF』 2. Output selector switch is to 『ECO』 	<ol style="list-style-type: none"> 1. Turn to 『ON』 2. Turn to 『SINGLE』 or 『DUAL』
AC Output is Weak	<ol style="list-style-type: none"> 1. The power consumption of the load exceeds the rated output 2. Dual Use 	<ol style="list-style-type: none"> 1. Adjust according to 『OUTPUT LIMITATION』 2. Stop welding
Slow-Down does not activate	<ol style="list-style-type: none"> 1. Short circuit of welding cable 2. The power consumption of the load is 0.5A or below 	<ol style="list-style-type: none"> 1. Repair the short circuit 2. Turn the Slow-Down switch to 『OFF』
Engine does not stop	<ol style="list-style-type: none"> 1. Stop Solenoid disorder 	<ol style="list-style-type: none"> 1. Turn the fuel lever to 『CLOSE』 to stop and repair
Black and white smoke exhaust from muffler successively	<ol style="list-style-type: none"> 1. Overloaded use 	<ol style="list-style-type: none"> 1. Keep the duty cycle 2. Adjust according to 『OUTPUT LIMITATION』

14. Engine Wiring Diagram

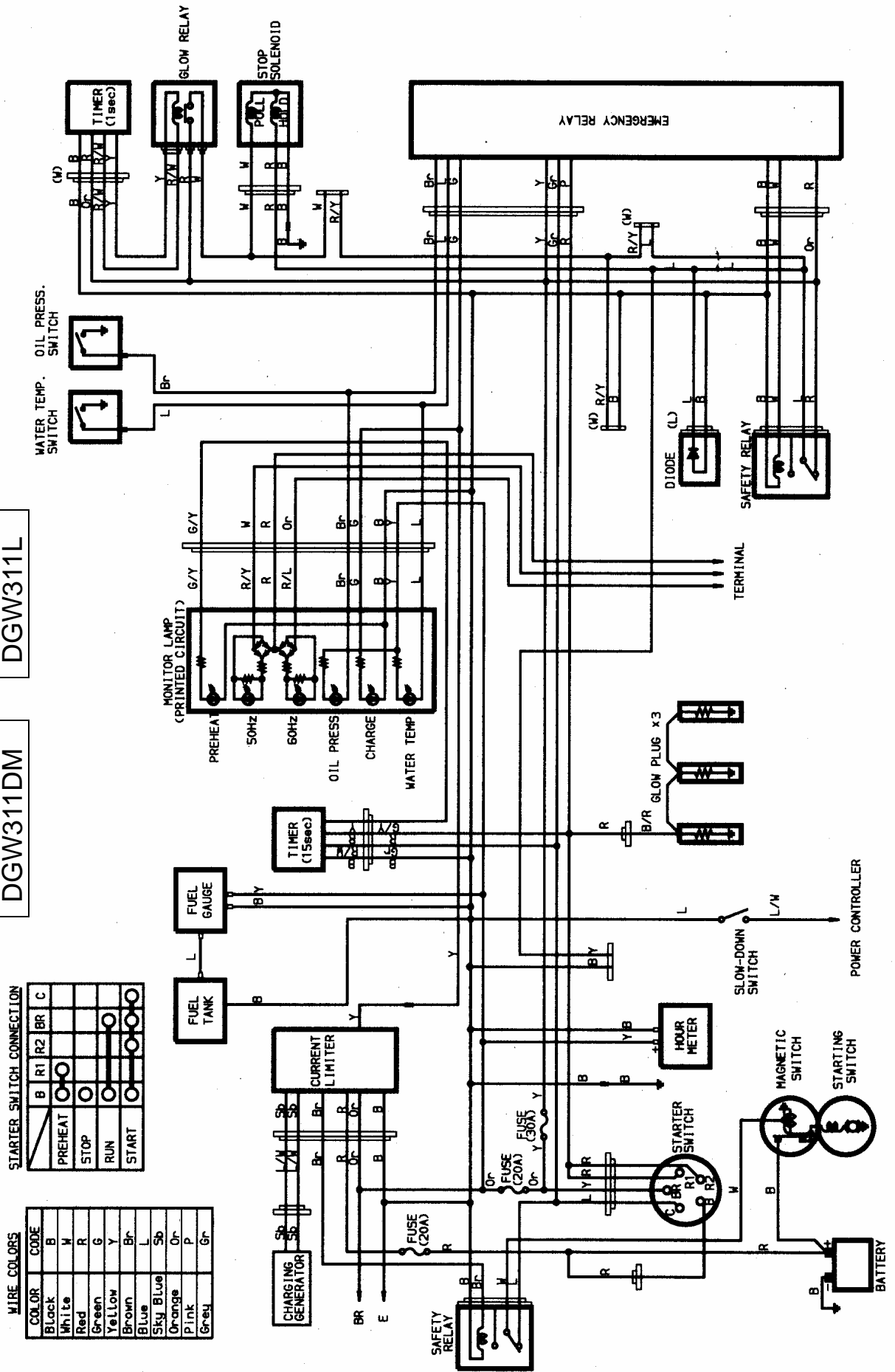

DGW311DM DGW311L

STARTER SWITCH CONNECTION

	B	R1	R2	BR	C
PREHEAT					
STOP					
RUN					
START					

WIRE COLORS

COLOR	CODE
Black	B
White	W
Red	R
Green	G
Yellow	Y
Brown	Br
Blue	L
Sky Blue	Sb
Orange	Or
Pink	P
Grey	Gr

15. Generator Wiring Diagram

DGW311DM-(W) 220B

(220V 60Hz)

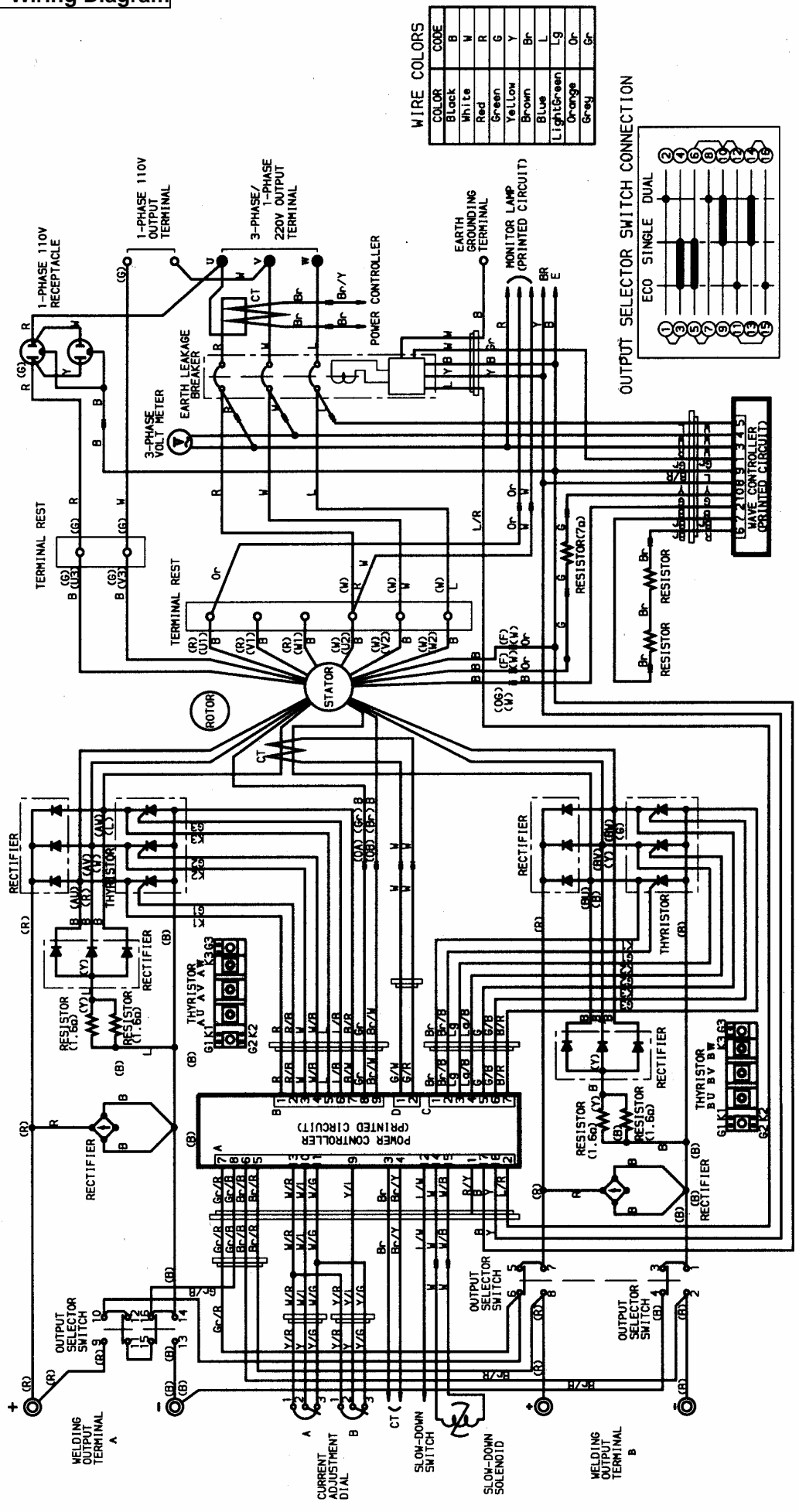

WIRE COLORS	COLOR	CODE
	Black	B
	White	W
	Red	R
	Green	G
	Yellow	Y
	Brown	Br
	Blue	L
	LightGreen	Lg
	Orange	Or
	Grey	Gr

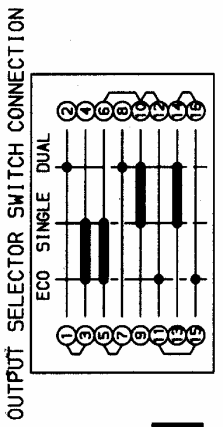

DGW311L - (W)220B

(220V 60Hz)

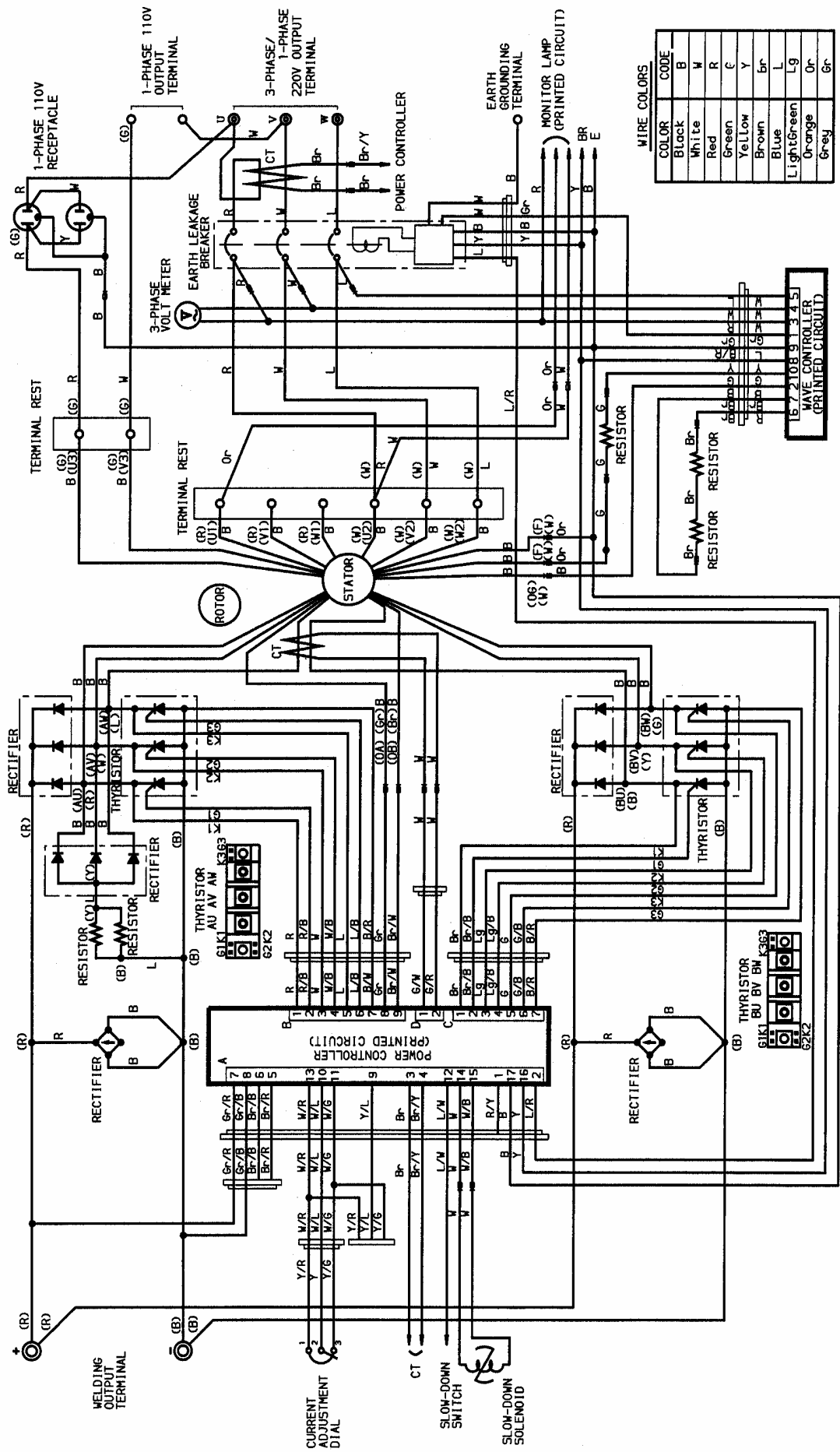

DGW311L - (W)380A

(380V 50HZ)

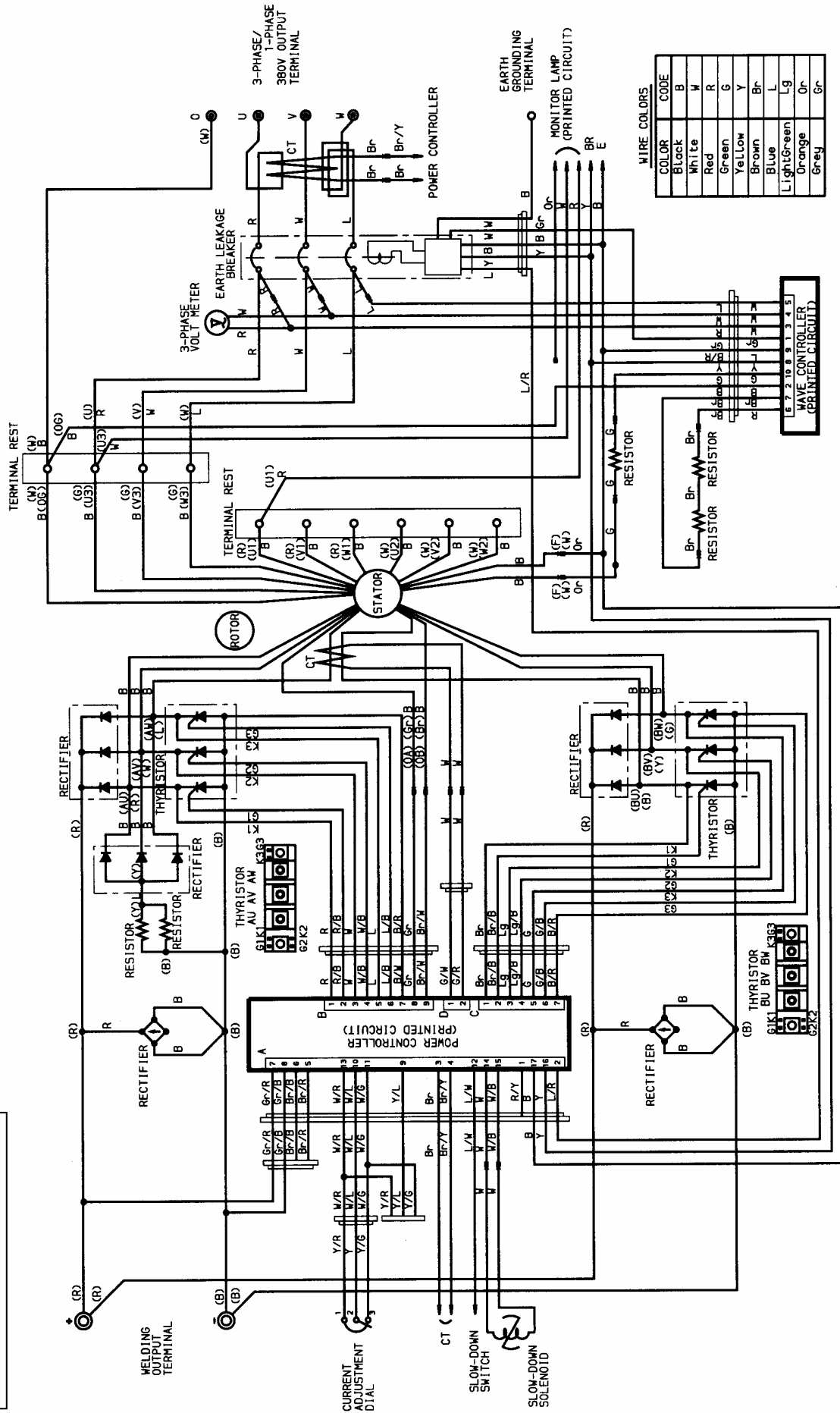

DGW311L - (W)400A (400V 50Hz)

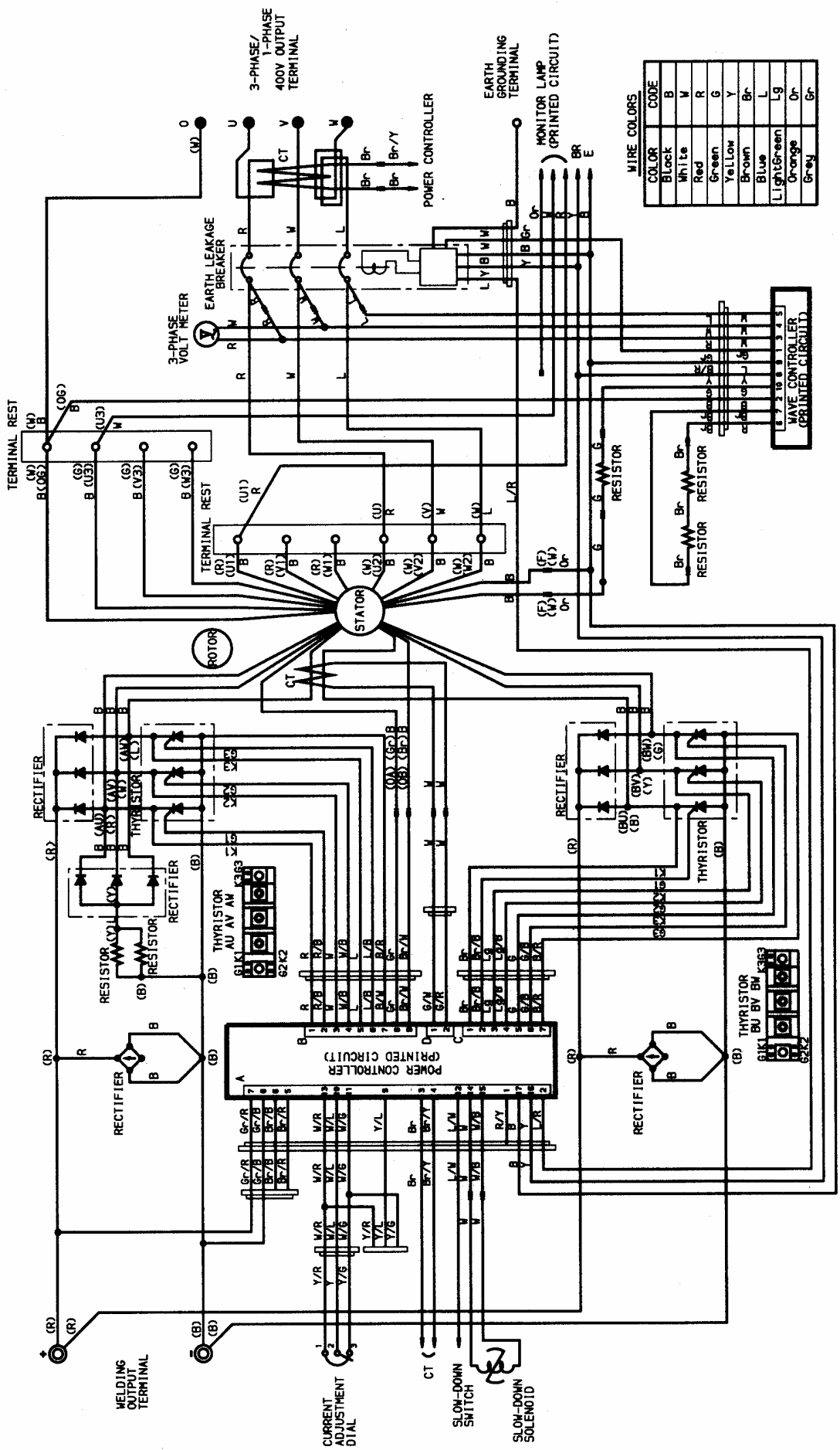

WIRE COLORS	
COLOR	CODE
Black	B
White	R
Red	R
Green	G
Yellow	Y
Brown	Br
Blue	L
LightGreen	Lg
Orange	Or
Grey	Gr

DGW311L - (W)415A

(415V 50Hz)

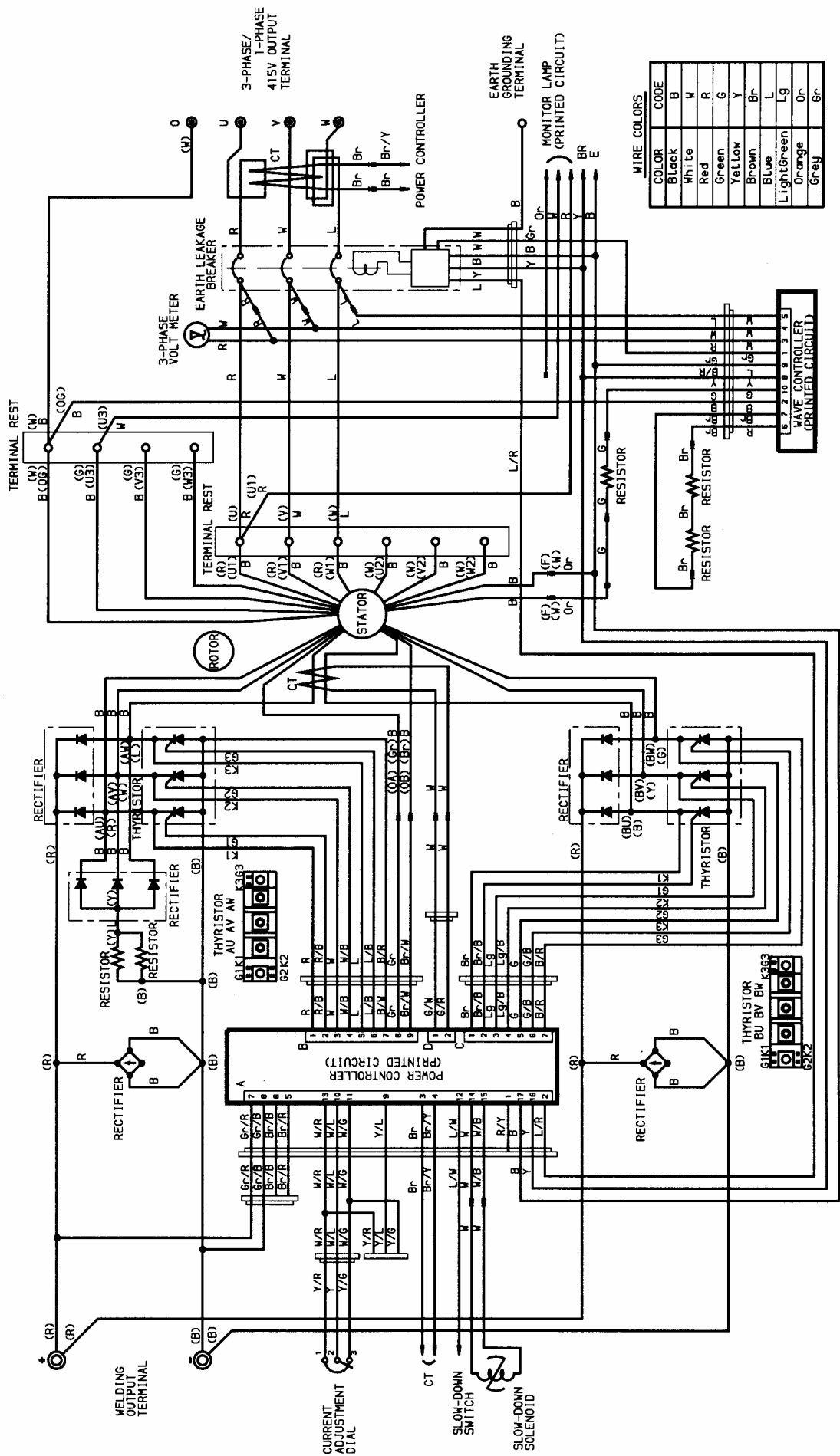

Shindaiwa Kogyo Co.,Ltd.

**Head Office : 6 - 2 - 11 , Ozuka - Nishi ,
Asaminami - Ku , Hiroshima ,
731 - 3167 , Japan**

Telephone : 81-82-849-2220 FAX : 81-82-849-2481