

SHURE®

LEGENDARY
PERFORMANCE™

GLXD6 Guitar Pedal Receiver / Tuner



User Guide

Shure Incorporated Confidential

Please Note: The following document layout is preliminary to identify, organize, and prioritize content. All copy including titles, descriptions, photos, specifications, and artwork are not final at this time.



DRAFT
3.4.13

IMPORTANT SAFETY INSTRUCTIONS

1. READ these instructions.
2. KEEP these instructions.
3. HEED all warnings.
4. FOLLOW all instructions.
5. DO NOT use this apparatus near water.
6. CLEAN ONLY with dry cloth.
7. DO NOT block any ventilation openings. Allow sufficient distances for adequate ventilation and install in accordance with the manufacturer's instructions.
8. DO NOT install near any heat sources such as open flames, radiators, heat registers, stoves, or other apparatus (including amplifiers) that produce heat. Do not place any open flame sources on the product.
9. DO NOT defeat the safety purpose of the polarized or grounding type plug. A polarized plug has two blades with one wider than the other. A grounding type plug has two blades and a third grounding prong. The wider blade or the third prong are provided for your safety. If the provided plug does not fit into your outlet, consult an electrician for replacement of the obsolete outlet.
10. PROTECT the power cord from being walked on or pinched, particularly at plugs, convenience receptacles, and the point where they exit from the apparatus.
11. ONLY USE attachments/accessories specified by the manufacturer.
12. USE only with a cart, stand, tripod, bracket, or table specified by the manufacturer, or sold with the apparatus. When a cart is used, use caution when moving the cart/apparatus combination to avoid injury from tip-over.
13. UNPLUG this apparatus during lightning storms or when unused for long periods of time.
14. REFER all servicing to qualified service personnel. Servicing is required when the apparatus has been damaged in any way, such as power supply cord or plug is damaged, liquid has been spilled or objects have fallen into the apparatus, the apparatus has been exposed to rain or moisture, does not operate normally, or has been dropped.
15. DO NOT expose the apparatus to dripping and splashing. DO NOT put objects filled with liquids, such as vases, on the apparatus.
16. The MAINS plug or an appliance coupler shall remain readily operable.
17. The airborne noise of the Apparatus does not exceed 70dB (A).
18. Apparatus with CLASS I construction shall be connected to a MAINS socket outlet with a protective earthing connection.
19. To reduce the risk of fire or electric shock, do not expose this apparatus to rain or moisture.
20. Do not attempt to modify this product. Doing so could result in personal injury and/or product failure.
21. Operate this product within its specified operating temperature range.



This symbol indicates that dangerous voltage constituting a risk of electric shock is present within this unit.



This symbol indicates that there are important operating and maintenance instructions in the literature accompanying this unit.

WARNING: This product contains a chemical known to the State of California to cause cancer and birth defects or other reproductive harm.



WARNING: Battery packs shall not be exposed to excessive heat such as sunshine, fire, or the like.



WARNING

- Battery packs may explode or release toxic materials. Risk of fire or burns. Do not open, crush, modify, disassemble, heat above 140°F (60°C), or incinerate
- Follow instructions from manufacturer
- Never put batteries in mouth. If swallowed, contact your physician or local poison control center
- Do not short circuit; may cause burns or catch fire
- Do not charge or use battery packs with other than specified Shure products
- Dispose of battery packs properly. Check with local vendor for proper disposal of used battery packs

WARNING: Danger of explosion if battery incorrectly replaced. Operate only with Shure compatible batteries.



Note:

- This equipment is intended to be used in professional audio applications.
- EMC conformance is based on the use of supplied and recommended cable types. The use of other cable types may degrade EMC performance.
- Use this battery charger only with the Shure charging modules and battery packs for which it is designed. Use with other than the specified modules and battery packs may increase the risk of fire or explosion.
- Changes or modifications not expressly approved by Shure Incorporated could void your authority to operate this equipment.



Note: Use only with the included power supply or a Shure-approved equivalent.

System Overview

GLX-D delivers superior digital audio in a compact, easy to use wireless system. More audio channels are placed on-air by taking advantage of the globally available 2.4 GHz spectrum. The compact low-profile design easily fits into pedalboard configurations. Built-in chromatic tuner simplifies setups while offering flexible tuning options. Advanced frequency hopping technology detects interference and automatically switches to a clear backup channel to prevent audio dropouts. Channel scanning finds the best receiver channel for wireless audio and automatically links to transmitter.

- Clear digital audio
- Operates in 2.4 GHz spectrum, available worldwide.
- Compact rugged metal construction
- Compatible with standard 9 V DC power supplies (250 mA minimum)
- Rechargeable transmitter batteries deliver cost-efficiency and up to 16 hours of runtime
- Adjustable transmitter gain to optimize audio signal
- Automatically detects and avoids interference to preserve audio quality
- RF back-channel for remote control of transmitter functions
- Automatic transmitter power-off to conserve battery life when transmitter is not in use.

Included Components

Shure Rechargeable Battery	SB902
Micro USB Battery Charger	SBC-USB
Power Supply	PS23
Premium Guitar Cable	WA305

Optional Accessories

Car Battery Charger	SBC-CAR
Docking Battery Charger	SBC-902

Quick Start

To reduce set up time, the transmitter and receiver automatically link to form an audio channel the first time they are powered on and never have to be linked again.

Note: If using multiple effects pedals, place the receiver pedal first in the signal chain.

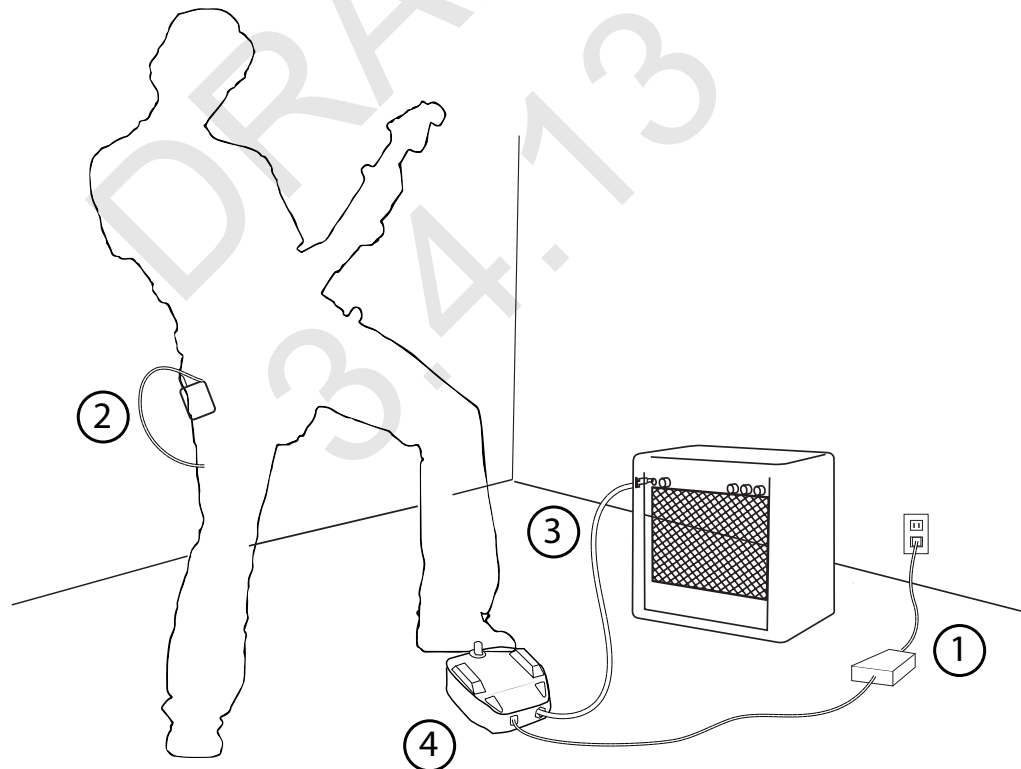

Step ①

Connect power supply to the receiver and plug the power cord into an AC power source.

Step ②

Connect the transmitter to the instrument and turn on the transmitter.

Step ③

Connect receiver audio output to an amplifier or mixer. Turn on the receiver and verify the blue RF LED is on.

Step ④

Check the audio and adjust the gain if necessary.

Guitar Pedal Receiver Overview

① Power Switch

Turns power on or off.

② DC Power Connector

Connect DC power supply (9 to 15 V DC, 250 mA min.)

Note: Compatible with positive tip or negative tip power supplies.

③ Audio Output Jack

Connect to amplifier or mixer.

Note: If using multiple effects pedals, place the receiver pedal first in the signal chain.

④ USB Port

⑤ Display

Displays receiver and tuner settings.

⑥ Antenna

Carries wireless signal, 2 per receiver.

⑦ Footswitch

Press to select receiver or tuner mode.

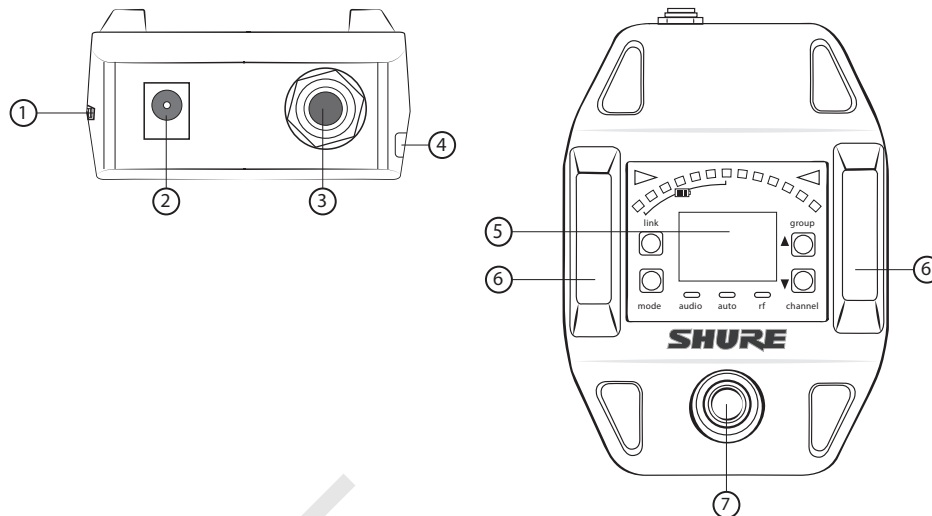

Display Screen, Indicators, and Controls

The controls and display offer specific functionality depending on which mode is selected:

Receiver Mode

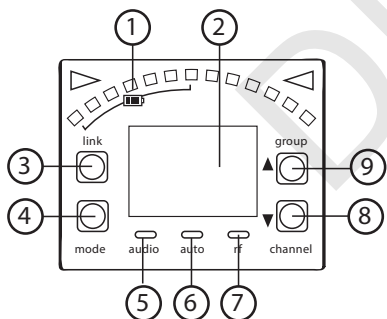

① Transmitter Battery Meter

Illuminated segments indicate remaining battery life

② Display

Group
Channel

LK (controls locked)

UN (controls unlocked)

-- (frequency not available)

③ Link Button

Press to manually link receiver to a transmitter or activate the remote ID function

④ Mode Button

Press to enable audio gain adjustment. Use ▲ ▼ buttons to adjust gain.

⑤ Audio LED

Illumination corresponds to audio level.

⑥ Auto LED

Illuminates if selected group has backup channels available.

⑦ RF LED

- ON = Linked transmitter is on
- Flashing = Searching for transmitter
- OFF = Linked transmitter off or transmitter unlinked

⑧ Channel Button

Press to select and edit channel

⑨ Group Button

Press to select and edit group

Tuner Mode

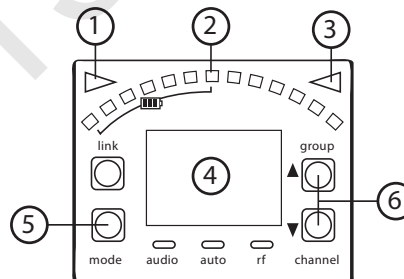

① Flat Indicator

Illuminates when note is flat.

② Tuning Bar Display

LEDs illuminate to indicate tuning deviation.

③ Sharp Indicator

Illuminates when note is sharp.

④ Note Display

Displays the name of the note or (--) if the tuner is idle.

⑤ Mode Button

Press to enter tuner menu settings.

⑥ Arrow Buttons

Use ▲ ▼ buttons to select and edit menu settings.

Bodypack Transmitter

① **Antenna**

Carries wireless signal.

② **Status LED**

Indicates transmitter status.

③ **Power Switch**

Turns the transmitter on/off.

④ **TA4M Input Jack**

Connects to a 4-Pin mini connector (TA4F) microphone or instrument cable.

⑤ **Micro USB Charging Port**

Connection for battery charging.

⑥ **Link Button**

- Press and hold within 5 seconds of power-on to manually link with receiver
- Press momentarily to activate Remote ID function to a linked receiver

⑦ **Battery Compartment**

Holds Shure rechargeable battery.



Transmitter Status LED

LED is green during normal operation.

LED color or flashing indicates a change in transmitter status as shown in the following table:

Color	State	Status
Green	Flashing (slow)	Transmitter attempting relink with receiver
	Flashing (fast)	Unlinked transmitter searching for receiver
	Flashes 3 times	indicates locked transmitter when power switch is pressed
Red	On	battery life < 1 hour
	Flashing	battery life < 30 minutes
Red/Green	Flashing	remote ID active
Amber	Flashing	battery error, replace battery

Wearing the Bodypack Transmitter

Clip the transmitter to a belt or slide a guitar strap through the transmitter clip as shown.

For best results, the belt should be pressed against the base of the clip.

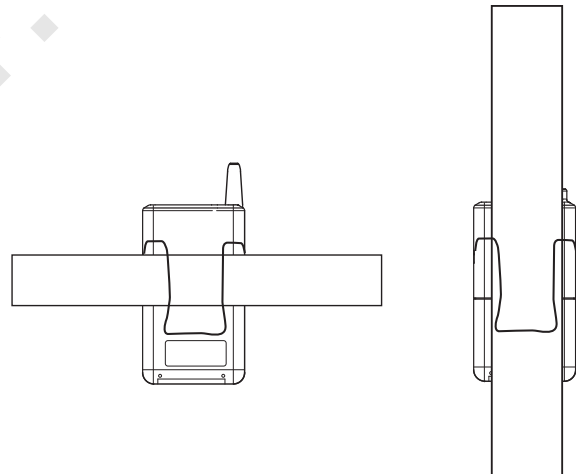

Batteries and Charging

GLX-D transmitters are powered by Shure SB902 lithium-ion rechargeable batteries. Advanced battery chemistry maximizes runtimes with zero memory effects, eliminating the need to discharge batteries prior to charging.

When not in use, recommended battery storage temperature is 10°C (50°F) to 25°C (77°F).

Note: The transmitter will not pass RF or audio signals when connected to the charging cable.

The following battery charging options are available:

Charging from an AC Power Source

For fastest battery charging, use an AC power source to charge the battery.

1. Plug the charging cable into the charging port on the transmitter.
2. Plug the charging cable into an AC power source.

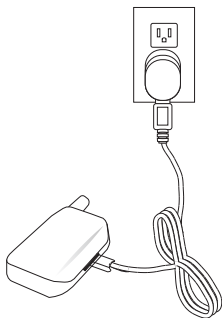

Charging from a USB Port

The USB charger is a convenient option for charging the battery using power from a standard USB port commonly found on computers and other devices.

1. Plug the USB charging cable into the charging port on the transmitter.
2. Plug the cable into a standard USB port.

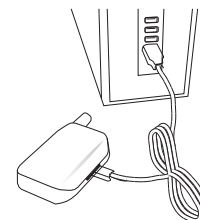

LED Status During Charging

The following LED states indicate battery status when the transmitter is connected to a charger:

- Green = charging complete
- Green Flashing = battery charge > 90%
- Red = battery charging
- Amber Flashing = battery error, replace battery

Charging Times and Transmitter Runtimes

Use the following table to determine approximate battery runtime based on the duration of charging time. Times shown are in hours and minutes.

Note: Batteries charge faster when using an AC powered charger versus a USB connection.

AC Power Source Charging	USB Connection Charging	Transmitter Runtime
0:15	0:30	up to 1:30
0:30	1:00	up to 3:00
1:00	2:00	up to 6:00
3:00	4:00	up to 16:00*

*Storage time or excessive heat will reduce maximum runtime.

Note: GLX-D transmitters automatically power-off after approximately 1 hour to conserve battery life if the signal from a linked receiver is not detected.

Installing Transmitter Batteries

Bodypack Transmitter

1. Move the locking lever to the open position and slide the battery door open.
2. Place the battery into the transmitter.
3. Close the battery door and slide door to engage the latch.

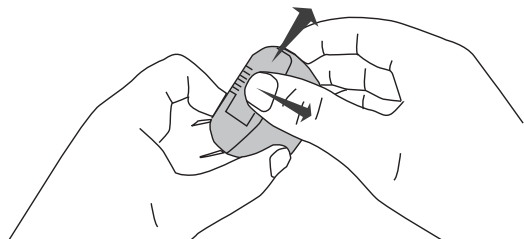

Transmitter Battery Meter

The number of segments illuminated on the meter indicates the remaining battery life for a linked transmitter:

- ① = > 30 min
- ② = > 2 hours
- ③ = > 4 hours
- ④ = > 6 hours
- ⑤ = > 8 hours
- ⑥ = > 10 hours
- ⑦ = > 12 hours

Note: The LEDs will cycle on/off while battery life is being calculated.

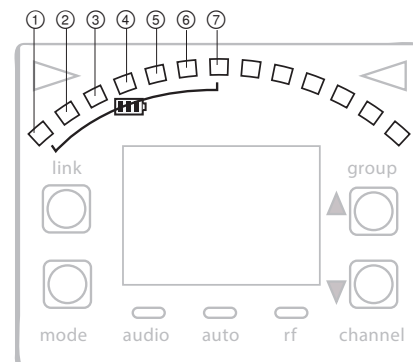

Multiple Receiver Systems

If several channels of wireless audio are needed, up to 8 GLX-D receivers can operate simultaneously in the 2.4 GHz spectrum. For ease of set up, available frequencies are divided into three groups based on the number of receivers supported.

All receivers in the system must be set to the same group. To select a group, determine the total number of receivers in the system (channel count), and then select the appropriate group.

Note: To maximize the number of receivers on-air, Group 3 does not offer backup frequencies. Group 3 should only be used in controlled Wi-Fi environments to prevent interference from unexpected Wi-Fi devices.

Group	Channel Count	Backup Frequencies Available?	Notes
1	Up to 4	Yes	Initial Factory Setting.
2	Up to 5	Yes	Best Group to use if you experience interference.
3	Up to 8	No	Only use Group 3 in controlled Wi-Fi environments because there are no backup frequencies to avoid interference.

Note: If you experience interference, reduce transmitter to receiver distance and set all GLX-D systems to group 2, which is the most robust wireless group.

See "Tips to Improve Wireless System Performance" section for additional steps if needed.

Setting Up Receivers and Transmitters

Note: Before beginning, turn off all receivers and transmitters. Turn on and set up each receiver/transmitter pair individually to prevent cross-linking.

1. Turn on the first receiver.
2. Press and hold the group button to select a group (if necessary) or if the group is already set, press the channel button to scan for the best available channel.
3. Turn on the first transmitter. The blue RF light will illuminate when a link is established.

Repeat steps 1-3 for each additional receiver and transmitter. Remember to set each receiver to the same group.

Note: Dashes appearing on the group and channel display during a channel scan indicate that frequencies are not available in the selected group. Choose a group that supports more receivers and repeat the set up steps.

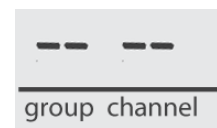

Manually Selecting a Group and Channel

Specific groups and channels can be assigned to the receiver instead of using the automatic scan function.

Note: Group 3 should only be used in controlled Wi-Fi environments to prevent interference from unexpected Wi-Fi devices.

Selecting a Group

1. Press and hold the group button for 2 seconds until the group display flashes.
2. Press the group button to scroll through the available groups.
3. The receiver will automatically save the selected group.

Selecting a Channel

1. Press and hold the channel button for 2 seconds until the channel display flashes.
2. Press the channel button to scroll through the available channels.
3. The receiver will automatically save the selected channel.

Note: A double dash symbol -- displayed on the receiver screen during a channel scan indicates that there are no available channels within the selected group. Choose a group with more channels and repeat set up steps.

Manually Linking a Transmitter to a Receiver

Use the manual linking option to change the transmitter linked to a receiver. For example, changing the linked transmitter from a bodypack to a handheld.

Use the following steps to manually change the transmitter linked to a receiver:

1. Turn on the transmitter: Within 5 seconds, press and hold the LINK button until the transmitter LED begins to flash green.
2. Press and hold the link button on the receiver: The blue r-f LED will flash, and then remain on when the link has been established.
3. Test the audio to verify the link and adjust the gain if necessary.

2.4 GHz Spectrum Overview

GLX-D operates within the 2.4GHz ISM band which is utilized by for Wi-Fi, Bluetooth, and other wireless. The benefit of 2.4GHz is that it's one global band that can be used anywhere in the world, license free.

Overcoming the Challenges of 2.4GHz

The challenge of 2.4GHz is that Wi-Fi traffic can be unpredictable. GLX-D meets these challenges in the following ways:

- Prioritizes and transmits on the best 3 frequencies per channel (choosing from a pool of 6 frequencies across the 2.4GHz band)
- Repeats the most important information such that one frequency can be taken out entirely without audio interruption
- Continuously scans during usage to rank all frequencies (both current and backup frequencies)
- Seamlessly moves away from interference to backup frequencies without audio interruption

Coexisting with Wi-Fi

GLX-D avoids continuous Wi-Fi traffic by scanning the entire 2.4GHz environment and selecting the 3 best frequencies to transmit on. The result of this is reliable performance for your GLX-D wireless system as well as avoiding Wi-Fi transmissions which may be important as well.

"Bursting" Wi-Fi is harder to detect as it is periodic; however, because GLX-D repeats the most important information even if these bursts are very high-level, they don't have an effect on your audio performance.

Challenging Wireless Environments

Some environments are more difficult than others for 2.4 GHz wireless system performance. The simplest solution in many cases is to reduce the transmitter to receiver distance such as placing the receivers on the stage with a clear line of sight.

Challenging environments include:

- Outdoors
- Very high ceilings
- 3 or more GLX-D receivers in use
- Strong Wi-Fi presence
- Non-Shure 2.4 GHz systems in use

Tips to Improve Wireless System Performance

If you encounter interference or dropouts, try the following suggestions:

- Scan for the best available channel (press the channel button)
- Reposition the receiver so there is nothing obstructing a line of sight to the transmitter (including the audience)
- Keep the transmitter and receiver more than 2 meters (6 feet) apart
- Keep transmitter to receiver distance within 60 meters (200 feet) - place receivers on-stage within line of sight if possible
- Remove or relocate nearby sources of wireless interference, such as Wi-Fi devices or hotspots, cell phones, two-way radios, computers, media players, and digital signal processors
- Disable non-essential Wi-Fi/bluetooth devices and avoid heavy Wi-Fi traffic activities such as downloading large files or viewing a movie.
- Locate GLX-D receivers away from non-Shure 2.4 GHz receivers
- Avoid placing transmitter and receiver where metal or other dense materials may be present
- Recharge or replace the transmitter battery
- Keep transmitters more than 2 meters (6 feet) apart

Note: GLX-D transmitters closer than 6 inches (15 cm) to other non-GLX-D transmitters may cause audible noise in that transmitter

- During sound check, mark trouble spots and ask presenters or performers to avoid those areas

2.4 GHz Frequency Tables

The following table lists receiver frequencies, channels, and latency for each group:

Group 1: Channels 1-4 (latency = 3.9 ms)

1/1	1/2	1/3	1/4
2424	2418	2411	2405
2425	2419	2413	2406
2442	2448	2430	2436
2443	2450	2431	2437
2462	2469	2476	2455
2464	2471	2477	2457

Group 2: Channels 1-5 (latency = 7.3 ms)

2/1	2/2	2/3	2/4	2/5
2423	2404	2417	2417	2437
2424	2405	2418	2418	2438
2443	2426	2451	2451	2462
2444	2427	2452	2452	2463
2473	2456	2468	2468	2477
2474	2457	2469	2469	2478

Group 3: Channels 1-6 (latency = 7.3 ms)

3/1	3/2	3/3	3/4	3/5	3/6
2415	2422	2426	2447	2409	2431
2416	2423	2427	2448	2451	2462
2443	2439	2457	2468	2452	2463

Receiver Operation

Audio Gain Adjustment

Transmitter gain has an adjustment range from -20 dB to +40 dB, in 1 dB increments.

Tip: Try the 0 dB (unity gain) setting as a starting point, and then make gain adjustments if necessary.

1. Press and hold the mode button on the receiver until dB appears on the display.
2. Press the up/down arrows to adjust the gain.

Note: The intensity of the green **audio** LED corresponds to the audio level.

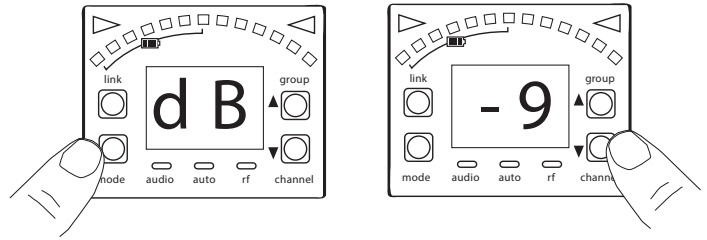

Locking and Unlocking the Controls

The controls of the receiver and transmitter can be locked to prevent accidental or unauthorized changes to settings.

The following parameters are not affected by locking the controls:

- Lock status is not changed by power cycles
- Tuner functionality and editing remains available
- The receiver power switch does not lock

Locking the Receiver Controls

Simultaneously press and hold the group and channel buttons to lock or unlock the receiver.

- LK is displayed if a locked control is pressed
- UN is displayed momentarily to confirm the unlock command

Locking the Transmitter Power Switch

Starting with the transmitter set to off, press and hold the LINK button while turning on the transmitter. Repeat sequence to unlock.

Note: The transmitter status LED will flash red/green if a locked switch is set to the off position.

Remote ID

Use the Remote ID feature to identify linked transmitter and receiver pairs. When Remote ID is active, the receiver LCD will blink and display ID. The status LED of the corresponding transmitter will alternately flash red and green for approximately 45 seconds.

To activate Remote ID:

1. Momentarily press the link button on the transmitter or receiver.
2. The display of the linked receiver will blink and show ID and the status LED on the linked transmitter will flash red/green.
3. To exit Remote ID mode, momentarily press the link button or allow the function to timeout.

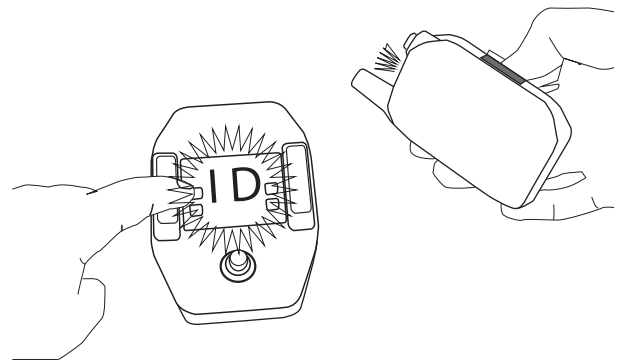

Tuner Menu

Enter tuner mode by pressing the footswitch. In tuner mode, the controls will only affect tuner functions. Receiver RF setting will not be affected.

Tuner Options

- Indicator: Needle or Strobe
- Output: Live or Mute
- Display Brightness
- Detune
- Sharps and Flats
- Frequency Offset

Selecting and Editing Tuner Menu Settings

Use the following buttons to select and edit the tuner menu settings:

- Use the mode button access the menu and to scroll between menu settings
- Use the Use ▲ ▼ buttons to change a menu parameter
- Use the footswitch to enter and save parameter changes

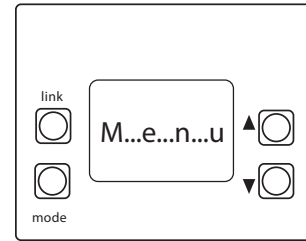

Indicator: Needle or Strobe

The tuner indicator can be set to display a needle style or strobe style.

Needle

A single LED will illuminate on the tuning bar to indicate sharp or flat. The green center LED will illuminate when the note is in tune.



Strobe

A sequence of three LEDs will travel across the tuning bar in the direction of sharp or flat. The LEDs will remain stationary when the note is in tune.



Note: Indicator and Output settings are displayed in a scroll from left to right.

Output: Live or Mute

The audio output can be set to Live or Mute in tuning mode:

- **Live:** Audio is passed to the amplifier or mixer
- **Mute:** Audio is muted at the pedal output

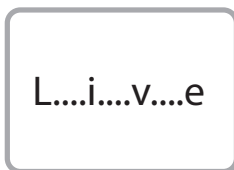

Note: Indicator and Output settings are displayed in a scroll from left to right.

Display Brightness

The receiver has a built-in light sensor to automatically adjust the display brightness.

To manually adjust the brightness choose one of the following settings:

- * A
 - * 1
 - * 2
 - * 3
- *A = automatic *1 = low *2 = medium *3 = high

Detune

The Detune feature can detect instruments that have been detuned up to 2 semitones (half steps).

The display will indicate the detuning as follows:



b0 = Standard Tuning



b1 = 1 Semitone

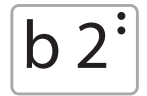

b2 = 2 Semitones

Note: Two dots appear in the display as a reminder that the pedal is detuned.

Sharps and Flats

Adds sharp or flat symbols to the display of non-natural notes.



Sharps and Flats



Flats only



Sharps only

Frequency Offset

Frequency Offset adjusts the reference frequency from A440. The range of adjustment is 432 Hz to 447 Hz in 1 Hz increments.

When adjusting the frequency, the last 2 digits of the value will show. For example, "32" would appear on the display when the frequency has been set to 432 Hz.

Note: Two dots appear in the display as a reminder that the reference frequency is offset.



Using the Tuner

1. Press the footswitch to enter tuner mode.
2. Play each note individually. The display shows the name of the note.
3. Adjust tuning until both indicators illuminate and the needle or strobe indicate that tuning is correct.

Needle Mode

Both tuning indicators and the center green segment will illuminate when the note is in tune.

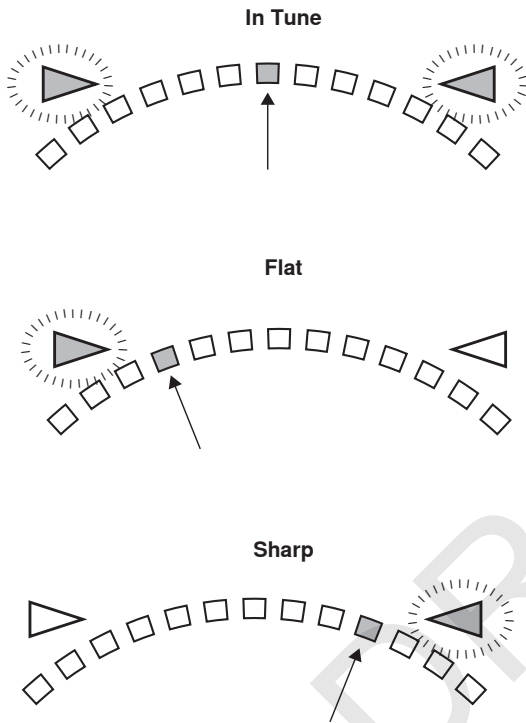

Strobe Mode

Both tuning indicators will illuminate and the strobe segments will remain stationary when the note is in tune.

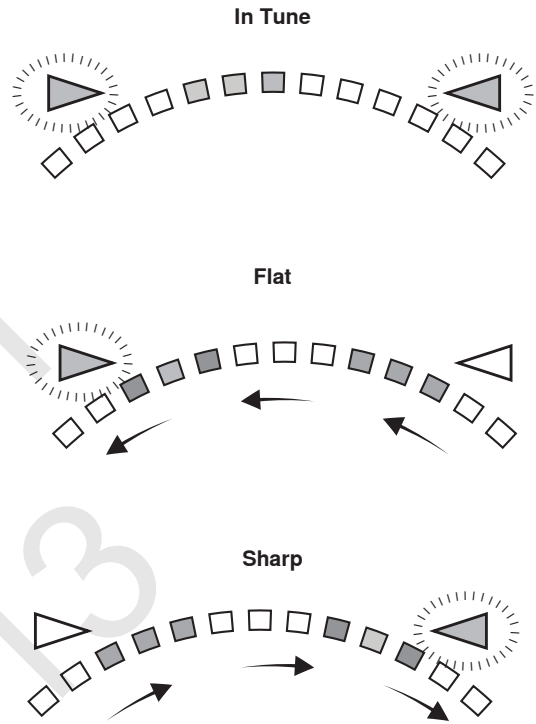

Troubleshooting

Issue	Indicator Status	Solution
No sound or faint sound	Receiver RF LED on	<ul style="list-style-type: none"> • Verify all sound system connections or adjust gain as needed (see Adjusting Gain) • Verify that the receiver is connected to mixer/amplifier
	Receiver RF LED off	<ul style="list-style-type: none"> • Turn on transmitter • Make sure the batteries are installed correctly • Link transmitter and receiver (see Linking topic) • Charge or change transmitter battery
	Receiver LCD screen off	<ul style="list-style-type: none"> • Make sure AC adapter is securely plugged into electrical outlet. • Make sure receiver is powered on.
	Transmitter indicator LED flashing red	Charge or change transmitter battery
	Transmitter plugged into charger.	Disconnect transmitter from charger.
Audio artifacts or dropouts	r-f LED flickering or off	<ul style="list-style-type: none"> • Change receiver and transmitter to a different group and/or channel. • Identify nearby sources of interference (cell phones, Wi-Fi access points, signal processor, etc...) and shutdown or remove source. • Charge or change transmitter battery • Ensure that receiver and transmitter are positioned within system parameters • System must be set up within recommended range and receiver kept away from metallic surfaces. • Transmitter must be used in line of sight from receiver for optimal sound
Distortion	OL indicator appears on receiver LCD	Reduce transmitter gain (see Gain Adjustment).
Sound level variations when switching to different sources	N/A	Adjust transmitter gain as necessary (see Gain Adjustment).
Receiver/transmitter won't turn off	Transmitter LED flashing rapidly	Controls locked. See Locking and Unlocking Controls.
Receiver gain control cannot be adjusted	N/A	Check transmitter. Transmitter must be on to enable gain changes.
Receiver controls cannot be adjusted	LK shown on receiver display when buttons are pressed	Controls locked. See Locking and Unlocking Controls.
Transmitter ID function does not respond.	Transmitter LED flashes green 3 times	Controls locked. See Locking and Unlocking Controls.
Transmitter information does not appear on the Receiver LCD	N/A	Linked transmitter is off or the receiver is not linked to a transmitter.
Transmitter powers off after 1 hour.	Transmitter status LED off	GLX-D transmitters automatically power-off after 1 hour to conserve battery life if the signal from a linked receiver is not detected. Make sure that linked receiver is turned on.

Resetting Components

Use the reset function if it is necessary to restore the transmitter or receiver to their factory settings.

Resetting the Receiver

Restores the receiver to the following factory settings:

- Gain level = default
- Controls = unlocked

Press and hold the link button while turning on the receiver power until the LCD displays RE.

Note: When reset is complete, the receiver will automatically initiate linking to search for a transmitter. Press and hold the transmitter link button within five seconds of powering-on to complete the link.

Resetting the Transmitter

Restores the transmitter to the following factory settings:

- Controls = unlocked

Press and hold the transmitter link button while turning on the transmitter until power LED goes off.

When the link button is released, the transmitter will automatically initiate linking to find an available receiver. Press the link button on an available receiver to relink.

Specifications

Tuning Bandwidth

2400–2483.5 MHz

Working Range

60 m (200 ft) typical

Note: Actual range depends on RF signal absorption, reflection and interference.

Transmit Mode

Frequency Hopping

Audio Frequency Response

20 Hz – 20 kHz

Dynamic Range

120 dB, A-weighted

Latency

RF Sensitivity

-88 dBm, typical

Total Harmonic Distortion

0.2%, typical

RF Output Power

10 mW E.I.R.P. max

Operating Temperature Range

-18°C (0°F) to 57°C (135°F)

Note: Battery characteristics may limit this range.

Storage Temperature Range

-29°C (-20°F) to 74°C (165°F)

Polarity

Positive pressure on microphone diaphragm (or positive voltage applied to tip of WA302 phone plug) produces positive voltage on pin 2 (with respect to pin 3 of low-impedance output) and the tip of the high impedance 1/4-inch output.

Battery Life

Up to 16 hours

GLXD1

Dimensions

90.4 x 64.5 x 22.9 mm (3.56 x 2.54 x 0.90 in.), H x W x D (without antenna)

Power Requirements

3.7 V Rechargeable Li-Ion

Housing

Cast Metal, Black Powdercoat

Input Impedance

900 kΩ

RF Output Power

10 mW E.I.R.P. max

Transmitter Input

Connector

4-Pin male mini connector (TA4M)

Configuration

Unbalanced

Maximum Input Level

1 kHz at 1% THD
+8.4 dBV (7.5 Vp-p)

Antenna Type

Internal Monopole

Pin Assignments

TA4M

1	ground (cable shield)
2	+ 5 V Bias
3	audio
4	Tied through active load to ground (On instrument adapter cable, pin 4 floats)



- ① Ground
- ② Bias Voltage
- ③ Audio Input
- ④ Active Load

TA4M Connector

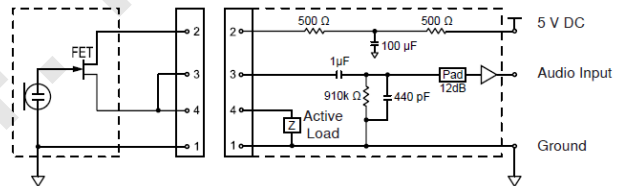

GLXD6

Dimensions

46 x 95 x 133 mm (1.8 x 3.7 x 5.2 in.), H x W x D

Weight

504 g (17.8 oz.)

Housing

Cast Metal, Black Powdercoat

Power Requirements

9 to 15 V DC (negative ground), 250 mA

Spurious Rejection

>35 dB, typical

Gain Adjustment Range

-20 to 40 dB in 1 dB steps

Configuration

6.35 mm (1/4") output	Impedance balanced
-----------------------	--------------------

Impedance

6.35 mm (1/4") output	100 Ω (50 Ω , Unbalanced)
-----------------------	--

Maximum Audio Output Level

6.35 mm (1/4") connector (into 3 k Ω load)	+8.5 dBV
---	----------

Pin Assignments

6.35 mm (1/4") connector	Tip=audio, Ring=no audio, Sleeve=ground
--------------------------	---

Receiver Antenna Input

Impedance

50 Ω

Antenna Type

1/2 Wave Sleeve Dipole, non-removable

Maximum Input Level

-20 dBm

Output Connections

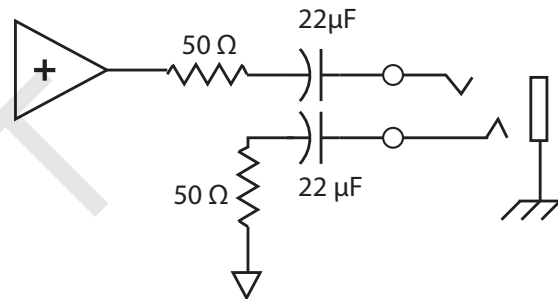

DRAFT
3.4.13

Certifications

This device complies with part 15 of the FCC Rules. Operation is subject to the following two conditions: (1) This device may not cause harmful interference, and (2) this device must accept any interference received, including interference that may cause undesired operation.

Meets requirements of the following standards: EN 300 328, EN 301 489 Parts 1 and 9, EN60065.

Meets essential requirements of the following European Directives:

- R&TTE Directive 99/5/EC
- WEEE Directive 2002/96/EC, as amended by 2008/34/EC
- RoHS Directive 2002/95/EC, as amended by 2008/35/EC

Note: Please follow your regional recycling scheme for batteries and electronic waste

Certified by IC in Canada under RSS-210 and RSS-GEN.

ic: 616A-GLXD1, 616A-GLXD6

Certified under FCC Part 15.

FCC ID: DD4GLXD1, DD4GLXD6

This Class B digital apparatus complies with Canadian ICES-003. Cet appareil numérique de la classe B est conforme à la norme NMB-003 du Canada.

This device complies with Industry Canada licence-exempt RSS standard(s). Operation of this device is subject to the following two conditions: (1) this device may not cause interference, and (2) this device must accept any interference, including interference that may cause undesired operation of the device.

Le présent appareil est conforme aux CNR d'Industrie Canada applicables aux appareils radio exempts de licence. L'exploitation est autorisée aux deux conditions suivantes : (1) l'appareil ne doit pas produire de brouillage, et (2) l'utilisateur de l'appareil doit accepter tout brouillage radioélectrique subi, même si le brouillage est susceptible d'en compromettre le fonctionnement.

The CE Declaration of Conformity can be obtained from Shure Incorporated or any of its European representatives. For contact information please visit www.shure.com

The CE Declaration of Conformity can be obtained from: www.shure.com/europe/compliance

Authorized European representative:

Shure Europe GmbH

Headquarters Europe, Middle East & Africa

Department: EMEA Approval

Jakob-Dieffenbacher-Str. 12

75031 Eppingen, Germany

Phone: 49-7262-92 49 0

Fax: 49-7262-92 49 11 4

Email: EMEAsupport@shure.de

Information to the user

This equipment has been tested and found to comply with the limits for a Class B digital device, pursuant to Part 15 of the FCC Rules. These limits are designed to provide reasonable protection against harmful interference in a residential installation. This equipment generates uses and can radiate radio frequency energy and, if not installed and used in accordance with the instructions, may cause harmful interference to radio communications. However, there is no guarantee that interference will not occur in a particular installation. If this equipment does cause harmful interference to radio or television reception, which can be determined by turning the equipment off and on, the user is encouraged to try to correct the interference by one or more of the following measures:

- Reorient or relocate the receiving antenna.
- Increase the separation between the equipment and the receiver.
- Connect the equipment to an outlet on a circuit different from that to which the receiver is connected.
- Consult the dealer or an experienced radio/TV technician for help.

DRAFT
3.4.13



United States, Canada, Latin America, Caribbean:
Shure Incorporated
5800 West Touhy Avenue
Niles, IL 60714-4608 USA

Phone: 847-600-2000
Fax: 847-600-1212 (USA)
Fax: 847-600-6446
Email: info@shure.com

www.shure.com

©2013 Shure Incorporated

Europe, Middle East, Africa:

Shure Europe GmbH
Jakob-Dieffenbacher-Str. 12,
75031 Eppingen, Germany

Phone: 49-7262-92490
Fax: 49-7262-9249114
Email: info@shure.de

Asia, Pacific:

Shure Asia Limited
22/F, 625 King's Road
North Point, Island East
Hong Kong

Phone: 852-2893-4290
Fax: 852-2893-4055
Email: info@shure.com.hk

PT. GOSHEN SWARA INDONESIA

Kompleks Harco Mangga Dua Blok L No. 35 Jakarta Pusat

I.16.GSI31.00501.0211