

SHURE®

LEGENDARY
PERFORMANCE™

Model PA421A
User Guide

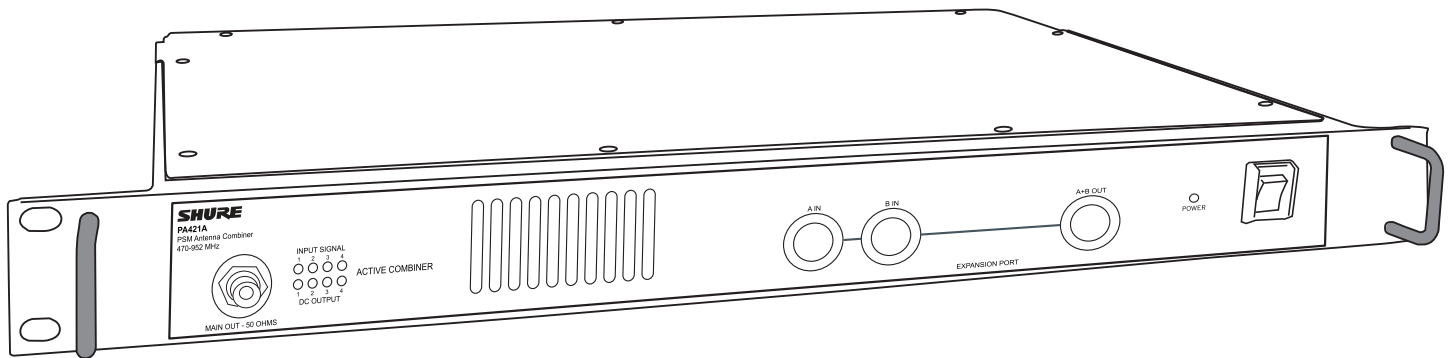

PA421A PSM® Antenna Combiner

Guide de l'utilisateur du répartiteur d'antenne PSM®

Bedienungsanleitung für die Antennenweiche PSM®

Guía del usuario del combinador de antenas PSM®

Guida d'uso del combinatore di antenne PSM®

Guia de usuário do combinador da antenas PSM®

Руководство пользователя Combiner антенны PSM®

PSM® アンテナコンバイナ ユーザーガイド

PSM® 天线合并器用户指南

PSM® 天線合并器用戶指南

PSM® Antenna Combiner 사용자 설명서





This symbol indicates that dangerous voltage constituting a risk of electric shock is present within this unit.



This symbol indicates that there are important operating and maintenance instructions in the literature accompanying this unit.

! IMPORTANT SAFETY INSTRUCTIONS !

1. READ these instructions.
2. KEEP these instructions.
3. HEED all warnings.
4. FOLLOW all instructions.
5. DO NOT use this apparatus near water.
6. CLEAN ONLY with dry cloth.
7. DO NOT block any ventilation openings. Install in accordance with the manufacturer's instructions.
8. DO NOT install near any heat sources such as radiators, heat registers, stoves, or other apparatus (including amplifiers) that produce heat.
9. DO NOT defeat the safety purpose of the polarized or grounding-type plug. A polarized plug has two blades with one wider than the other. A grounding type plug has two blades and a third grounding prong. The wider blade or the third prong are provided for your safety. If the provided plug does not fit into your outlet, consult an electrician for replacement of the obsolete outlet.
10. PROTECT the power cord from being walked on or pinched, particularly at plugs, convenience receptacles, and the point where they exit from the apparatus.
11. ONLY USE attachments/accessories specified by the manufacturer.
12.  USE only with a cart, stand, tripod, bracket, or table specified by the manufacturer, or sold with the apparatus. When a cart is used, use caution when moving the cart/apparatus combination to avoid injury from tip-over.
13. UNPLUG this apparatus during lightning storms or when unused for long periods of time.
14. REFER all servicing to qualified service personnel. Servicing is required when the apparatus has been damaged in any way, such as power-supply cord or plug is damaged, liquid has been spilled or objects have fallen into the apparatus, the apparatus has been exposed to rain or moisture, does not operate normally, or has been dropped.
15. DO NOT expose the apparatus to dripping and splashing. DO NOT put objects filled with liquids, such as vases, on the apparatus.
16. The MAINS plug or an appliance coupler shall remain readily operable.
17. The airborne noise of the apparatus does not exceed 70dB (A).
18. Apparatus with CLASS I construction shall be connected to a MAINS socket outlet with a protective earthing connection.
19. To reduce the risk of fire or electric shock, do not expose this apparatus to rain or moisture.
20. Do not attempt to modify this product. Doing so could result in personal injury and/or product failure.

WARNING: Voltages in this equipment are hazardous to life. No user-serviceable parts inside. Refer all servicing to qualified service personnel. The safety certifications do not apply when the operating voltage is changed from the factory setting.

WARNING: This product contains a chemical known to the State of California to cause cancer and birth defects or other reproductive harm.

OVERVIEW

The Shure PA421A Antenna Combiners actively combine antenna outputs from up to four PSM wireless transmitters to a single antenna, improving RF performance and reducing rack clutter.

INSTALLATION

1. Before installing, set the front panel power switch to OFF. (See Figure 1)
2. Using the supplied power cable connect the unit to an AC power source.
3. To use the device set the front panel power switch to ON. The power light will illuminate.
4. Before disconnecting the unit from the AC power source, or when not in use, power the unit OFF.

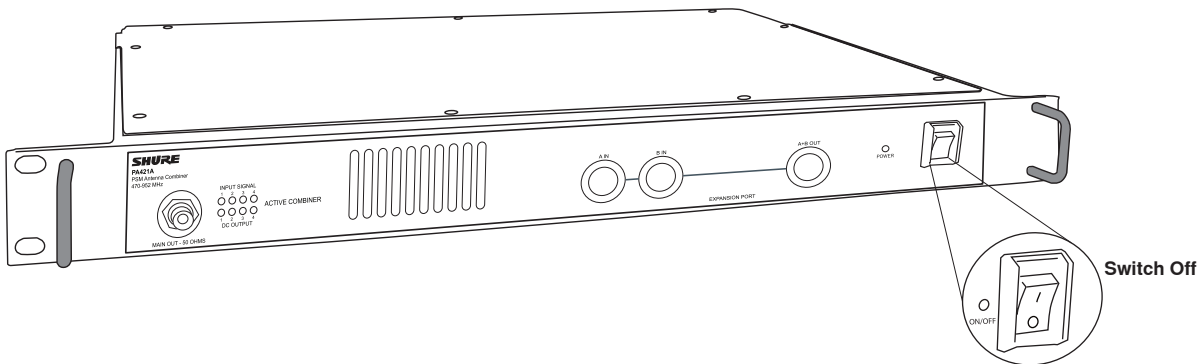

PA421A Benefits

- Reduction of intermodulation artifacts for cleaner RF environment and more channels on air
- Simplified antenna placement
- Power distribution

4-TO-1 COMBINING FOR PSM TRANSMITTERS

- Using the supplied BNC-BNC cables, connect the Antenna Output of each transmitter to the Antenna Inputs of the PA421A (See Figure 2).
- Attach an antenna to the MAIN Out of PA421A. For wideband applications, use PA805SWB directional antenna (Figure 2).
- Connect the PA421A to a power outlet using one of the supplied power cables. The PA421A contains a universal power supply to operate anywhere in the world.
- If you have a Shure PSM system that has the same power input connectors as the PA421A power outputs, such as the PSM900, connect the PSM system to the PA421A via the supplied power cables (see figure 2). This replaces the need for an external power supply.

NOTE: The PA421A supplied power is 15 V and up to 660 mA.

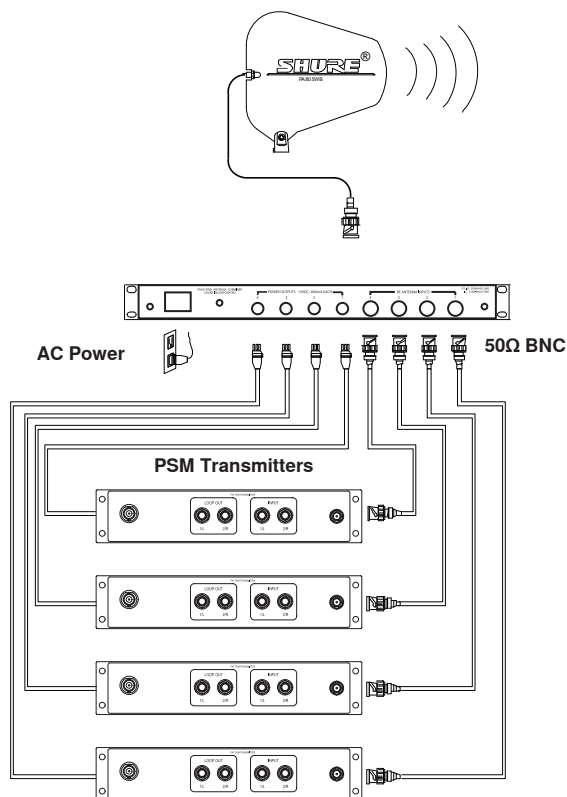

Figure 2

NOTE: When the PA421A is powered on, the input signal indicators (1-4) on the front panel will illuminate if an active transmitter is connected to the corresponding input (1-4) on the back panel (Figure 2).

SPECIFICATIONS

RF Carrier Frequency Range	470-952 MHz
System Gain	+0/-5 dB
Input AC Line Voltage	100-240 Vac, 50/60 Hz
Maximum Input Line Power	1.2A 80W
Maximum Current Drain	165VA 0.42-1.0 Amperes (Amperes = 100 VA/Input AC Line Voltage)
Maximum RF Input Power	24 dBm (250 mW) per channel
Input Signal Indicator Threshold	+4 dBm (2.5 mW), +2 dBm (1.6 mW) typical
Impedance	50 Ω nominal
AC Current Max	1.4A
Power Max	82W
Apparent Power Max	170VA

Operating Temperature Range	0° F (-18° C) to +145° F (+63° C)
NOTE: Electrical safety approval is based on a maximum ambient temperature of 30° C.	
Overall Dimensions	43.4 mm high x 398.8 mm wide x 331.5 mm deep (1 11/16 in. H x 15 11/16 in. W x 13 1/2 in. D)
Net Weight	4.53 Kg (10 lbs unpackaged, without power and RF cables)
Input/Output Connector Type	BNC-type 4 input, 1 output ACTIVE
Power Outputs (4)	15 VDC, 660 mA each

FURNISHED ACCESSORIES

(4) 2 ft. Coaxial Cable (RG58C/U)	UA802
(4) 2 ft. Output Power Cable	95B8420
120 VAC Power Line Cord	95A8389
230 VAC Power Line Cord	95A8247
240 VAC Power Line Cord (U.K.)	95A8713

OPTIONAL ACCESSORIES

Wideband Unidirectional Antenna (470-952 MHz)	PA805SWB
10 ft. Coaxial Cable (RG-8X/U)	PA725
25 ft. Coaxial Cable (RG-8X/U)	UA825
50 ft. Coaxial Cable (RG-8X/U)	UA850
Wide Band Omnidirectional Antenna (470-1100 MHz)	UA860SWB
Helical Antenna	HA-8089 (480-900 MHz) HA-8241 (944-952 MHz)

CERTIFICATIONS

PA421A: Certified to FCC Part 74 (FCC ID No. DD4PA421A). Certified in Canada by IC to RSS-123 AND RSS-102 (Certification No. IC: 616A-PA421A). UL LISTED to UL60065, 7th Edition and cUL LISTED to CAN/CSA E60065-00. Meets the Essential Requirements of the European R&TTE Directive 99/5/EC, eligible to bear CE mark. Meets EMC requirements of EN 301 489 Parts 1 and 9 and is GS-Certified to EN EN60065, 7th Edition. Conforms to Australian EMC requirements, eligible to bear C-Tick mark (N108).

LICENSING

Changes or modifications not expressly approved by Shure Incorporated could void your authority to operate the equipment. Licensing of Shure wireless microphone equipment is the user's responsibility, and licensability depends on the user's classification and application, and on the selected frequency. Shure strongly urges the user to contact the appropriate telecommunications authority concerning proper licensing, and before choosing and ordering frequencies.

THIS RADIO EQUIPMENT IS INTENDED FOR USE IN PROFESSIONAL ENTERTAINMENT AND SIMILAR APPLICATIONS.

NOTE

THIS EQUIPMENT MAY BE CAPABLE OF OPERATING ON SOME FREQUENCIES NOT AUTHORIZED IN YOUR REGION. PLEASE CONTACT YOUR NATIONAL AUTHORITY TO OBTAIN INFORMATION ON AUTHORIZED FREQUENCIES FOR WIRELESS MICROPHONE PRODUCTS IN YOUR REGION.

Licensing: Note that a ministerial license to operate this equipment may be required in certain areas. Consult your national authority for possible requirements.



**United States, Canada, Latin
America, Caribbean:**

Shure Incorporated
5800 West Touhy Avenue
Niles, IL 60714-4608 USA

Phone: 847-600-2000
Fax: 847-600-1212 (USA)
Fax: 847-600-6446
Email: info@shure.com

www.shure.com

©2010 Shure Incorporated

Europe, Middle East, Africa:

Shure Europe GmbH
Wannenäckestr. 28,
74078 Heilbronn, Germany

Phone: 49-7131-72140
Fax: 49-7131-721414
Email: info@shure.de

Asia, Pacific:

Shure Asia Limited
22/F, 625 King's Road
North Point, Island East
Hong Kong

Phone: 852-2893-4290
Fax: 852-2893-4055
Email: info@shure.com.hk