

PSM® Antenna Combiner User Guide

Guide de l'utilisateur du répartiteur d'antenne PSM

Bedienungsanleitung für die Antennenweiche PSM

Guía del usuario del combinador de antenas PSM

Guida d'uso del combinatore di antenne PSM

! IMPORTANT SAFETY INSTRUCTIONS !

1. READ these instructions.
2. KEEP these instructions.
3. HEED all warnings.
4. FOLLOW all instructions.
5. DO NOT use this apparatus near water.
6. CLEAN ONLY with dry cloth.
7. DO NOT block any ventilation openings. Install in accordance with the manufacturer's instructions.
8. DO NOT install near any heat sources such as radiators, heat registers, stoves, or other apparatus (including amplifiers) that produce heat.
9. DO NOT defeat the safety purpose of the polarized or grounding-type plug. A polarized plug has two blades with one wider than the other. A grounding type plug has two blades and a third grounding prong. The wider blade or the third prong are provided for your safety. If the provided plug does not fit into your outlet, consult an electrician for replacement of the obsolete outlet.
10. PROTECT the power cord from being walked on or pinched, particularly at plugs, convenience receptacles, and the point where they exit from the apparatus.
11. ONLY USE attachments/accessories specified by the manufacturer.
12.  USE only with a cart, stand, tripod, bracket, or table specified by the manufacturer, or sold with the apparatus. When a cart is used, use caution when moving the cart/apparatus combination to avoid injury from tip-over.
13. UNPLUG this apparatus during lightning storms or when unused for long periods of time.
14. REFER all servicing to qualified service personnel. Servicing is required when the apparatus has been damaged in any way, such as power-supply cord or plug is damaged, liquid has been spilled or objects have fallen into the apparatus, the apparatus has been exposed to rain or moisture, does not operate normally, or has been dropped.
15. DO NOT expose the apparatus to dripping and splashing. DO NOT put objects filled with liquids, such as vases, on the apparatus.

 This symbol indicates that there are important operating and maintenance instructions in the literature accompanying this unit.

 This symbol indicates that dangerous voltage constituting a risk of electric shock is present within this unit.

WARNING: Voltages in this equipment are hazardous to life. No user-serviceable parts inside. Refer all servicing to qualified service personnel. The safety certifications do not apply when the operating voltage is changed from the factory setting.

DESCRIPTION

The Shure PA821 Antenna Combiners actively combine antenna outputs from up to eight PSM wireless transmitters to a single antenna, improving RF performance and reducing rack clutter.

INSTALLATION

Set the power switch on the front panel to Off before installing. Connect the unit to an AC power source using the supplied power cable. Switch the power On to use the device. The power light will illuminate. Power the unit Off when not in use or before disconnecting the unit from the AC power source.

8-TO-1 COMBINING:

1. Using the supplied BNC-BNC cables, connect the **ANTENNA OUTPUT** of each transmitter to the **ANTENNA INPUTS** of the PA821 (Figure 2).
2. Attach an antenna to the **MAIN OUT** of PA821. For wideband applications, use PA805WB directional antenna (Figure 1).
3. Connect the PA821 to a power outlet using one of the supplied power cables. The PA821 contains a universal power supply to operate anywhere in the world.

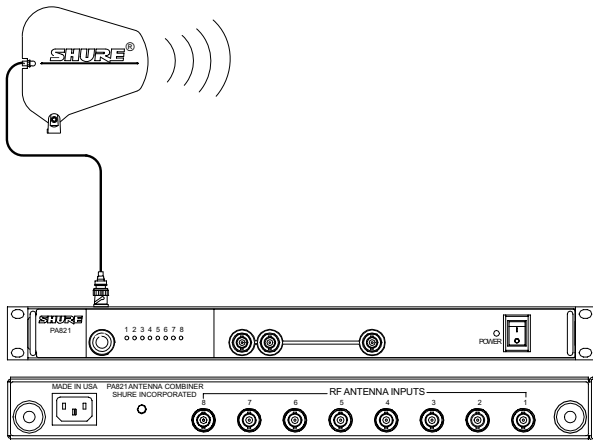

FIGURE 1

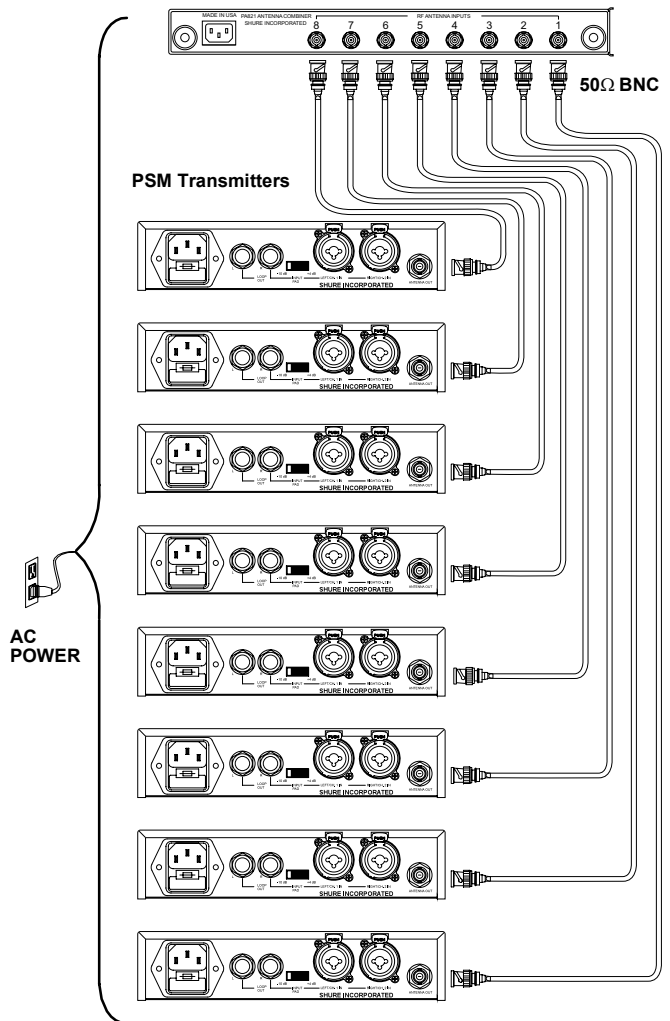

FIGURE 2

FOR MORE THAN 8 TRANSMITTERS:

1. Using the supplied BNC-BNC cables, connect the **ANTENNA OUTPUT** of each transmitter to the **ANTENNA INPUTS** of the PA821.
2. Use the 1 ft. jumper BNC-BNC cable to connect the **MAIN OUTPUT** of the PA821 to the **A IN** of the **EXPANSION PORT**.
3. Connect another **ANTENNA OUTPUT** (from a ninth PSM transmitter, second PA821 or other antenna port) to the **B IN** of the **EXPANSION PORT**.
4. Attach an antenna to the **A + B OUT** of the **EXPANSION PORT**. For wideband applications, use the PA805WB directional antenna. See Figure 3.

SPECIFICATIONS

RF Carrier Frequency Range

470-870 MHz (470-806 MHz in U.S.A. and Canada)

System Gain

+0/-5 dB

Output Port Isolation

Greater than 55 dB

Third Order Intercept Point (3 OIP)

Greater than 25 dBm

Input AC Line Voltage

100-240 Vac, 50/60 Hz

Maximum Input Line VA

100 VA

Maximum Current Drain

0.42-1.0 Amperes

(Amperes = 100 VA/Input AC Line Voltage)

Maximum RF Input Power

24 dBm (250 mW)

Impedance

50 Ω nominal

Operating Temperature Range

0° F (-18° C) to +135° F (+57° C)

NOTE: Electrical safety approval is based on a maximum ambient temperature of 35°C.

Overall Dimensions

43.4 mm high x 398.8 mm wide x 331.5 mm deep
(1 11/16 in. H x 15 11/16 in. W x 13 1/2 in. D)

Net Weight

4.53 Kg (10 lbs unpackaged, without power and RF cables)

Input/Output Connector Type

BNC-type 8 input, 1 output **ACTIVE**

2 Inputs, 1 output **EXPANSION PORT**

FURNISHED ACCESSORIES

- (8) 2 ft. Coaxial Cable (RG58/U) UA802
- 1 ft Jumper..... 95E2035
- 120 VAC Power Line Cord..... 95A8389
- 230 VAC Power Line Cord..... 95A8247
- 240 VAC Power Line Cord (U.K.) 95A8713

OPTIONAL ACCESSORIES

- Wideband Unidirectional Antenna (470-870 MHz) PA805WB
- 10 ft. Coaxial Cable (RG-58/U) PA725
- 25 ft. Coaxial Cable (RG-8/U)..... UA825
- 50 ft. Coaxial Cable (RG-8/U)..... UA850

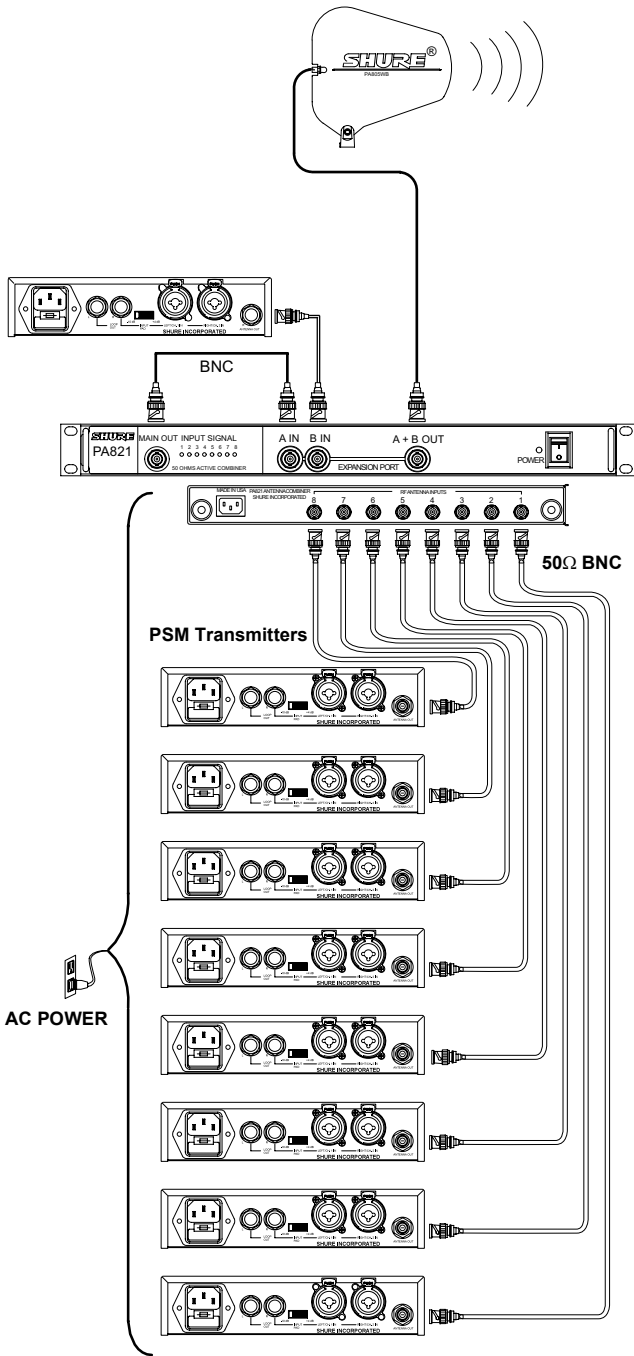

FIGURE 3

CERTIFICATIONS

PA821: Certified to FCC Part 74 (FCC ID No. DD4PA821). Certified in Canada by IC to RSS-123 AND RSS-102 (Certification No. IC 616A-PA821). UL Listed to UL6500 (2nd Edition) and cUL listed to CAN/CSA E60065-00. Meets the Essential Requirements of the European R&TTE Directive 99/5/EC, eligible to bear CE mark. Meets EMC requirements of EN 301 489 Parts 1 and 9 and is GS-Certified to EN 60065 (6th Edition). Conforms to Australian EMC requirements, eligible to bear C-Tick mark (N108).

LICENSING

Changes or modifications not expressly approved by Shure Incorporated could void your authority to operate the equipment. Licensing of Shure wireless microphone equipment is the user's responsibility, and licensability depends on the user's classification and application, and on the selected frequency. Shure strongly urges the user to contact the appropriate telecommunications authority concerning proper licensing, and before choosing and ordering frequencies.

THIS RADIO EQUIPMENT IS INTENDED FOR USE IN PROFESSIONAL ENTERTAINMENT AND SIMILAR APPLICATIONS.

NOTE: THIS EQUIPMENT MAY BE CAPABLE OF OPERATING ON SOME FREQUENCIES NOT AUTHORIZED IN YOUR REGION. PLEASE CONTACT YOUR NATIONAL AUTHORITY TO OBTAIN INFORMATION ON AUTHORIZED FREQUENCIES FOR WIRELESS MICROPHONE PRODUCTS IN YOUR REGION

Licensing: Note that a ministerial license to operate this equipment may be required in certain areas. Consult your national authority for possible requirements.



OPERATION OF THIS DEVICE IS SUBJECT TO THE FOLLOWING TWO CONDITIONS:

- 1) THIS DEVICE MAY NOT CAUSE INTERFERENCE, AND
- 2) THIS DEVICE MUST ACCEPT ANY INTERFERENCE, INCLUDING INTERFERENCE THAT MAY CAUSE UNDESIRE OPERATION OF THE DEVICE.