

**Shure SLX Wireless
Systems**

English2
Français
Deutsch.
Español.
Italiano
Portuguese.
Japanese
Chinese.
Russian.
Korean
Arabic

Shure SLX Wireless

Smart, Hard-working Wireless

Congratulations! Welcome to Shure SLX Wireless. Your new system is rugged, reliable, easy to set up and operate, and produces outstanding audio clarity. Whether you're a vocalist, guitarist, or instrumentalist, your SLX Wireless system will show you how easy wireless can be, and how good wireless can sound.

This user guide and the Quick Setup guide included with your system will tell you all you need to know to get your system working right away.

Welcome to the world of SLX: smart, hard-working wireless.

Frequency Band Selection

Most countries closely regulate the radio frequencies used in the transmission of wireless information. These regulations state which devices can use which frequencies, and help to limit the amount of RF (radio frequency) interference in all wireless communications.

To be flexible enough to operate worldwide, SLX receivers are available in multiple dedicated frequency models. Each dedicated frequency range, or **band**, spans up to 24 MHz of the wireless broadcast spectrum. Available bands are:

H5: 518–542 MHz	R5: 800–820 MHz
J3: 572–596 MHz	S6: 838–865 MHz
L4: 638–662 MHz	JB: 806–810 MHz
P4: 702–726 MHz	Q4: 740–752 MHz

To facilitate system setup and protect against RF interference, each system comes with multiple predefined frequency **groups** and **channels**.

When using a single SLX system, the operating frequency will generally not have to be changed. In an installation with multiple receiver/transmitter systems, each system must operate on a separate channel. The group and channel system provides an optimum frequency spread when using multiple systems.

Within a single frequency band, up to 12 individual transmitter/receiver systems may be used in a single installation. In regions where additional frequency bands are available, it is possible to operate up to 20 systems simultaneously. Check with your local Shure retailer for information on which bands are available in your area.

What Do You Want to Do Now?

Learn about your SLX4 Receiver

Power, lock/unlock, front and back panel features: See [“SLX4 Receiver Features”](#) on [page 5](#) and [“SLX4 Receiver Programming”](#) on [page 9](#).

Learn about your SLX2 Handheld Transmitter

Power, mute, gain, lock/unlock, other features: See [“SLX2 Handheld Transmitter”](#) on [page 6](#) and [“SLX1 and SLX2 Transmitter Programming”](#) on [page 10](#).

Learn about your SLX1 Bodypack Transmitter

Power, mute, gain, lock/unlock, other features: See [“SLX1 Bodypack Transmitter”](#) on [page 7](#) and [“SLX1 and SLX2 Transmitter Programming”](#) on [page 10](#).

Program your SLX Receiver and Transmitter

Frequency selection, LCD features, using the **select** and **menu** buttons: See [“SLX Programming”](#) on [page 9](#).

Learn how to use multiple systems in a single installation

See [“Multiple System Setup”](#) on [page 8](#).

Troubleshoot your SLX system

See [“Troubleshooting”](#) on [page 12](#).

Table of Contents

System Components4

SLX4 Receiver Features5

SLX2 Handheld Transmitter6

SLX1 Bodypack Transmitter.7

Single System Setup8

Multiple System Setup8

SLX Programming9

 SLX4 Receiver Programming9

 SLX1 and SLX2 Transmitter Programming10

 The Master Frequency List10

Rack-Mounting SLX Receivers.11

Receiver Volume Control12

Tips for Improving System Performance12

Troubleshooting12

Specifications13

Replacement Parts and Accessories.14

Microphone Specification.15–17

Frequency Ranges.18–20

Regulatory Statements21

System Components

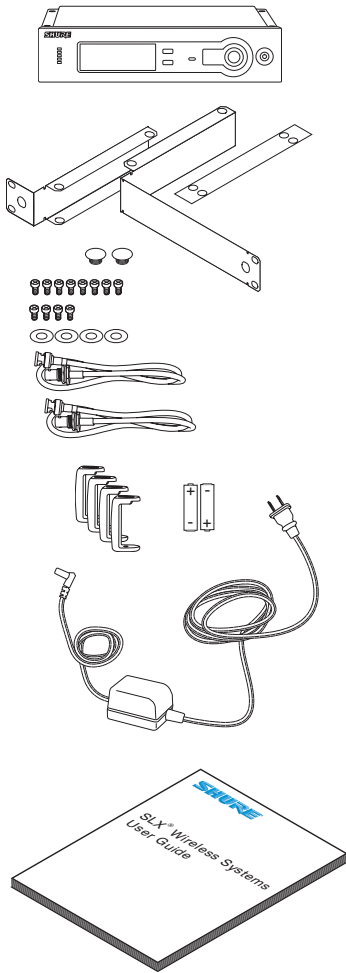

All systems include:

- SLX4 receiver
- Rack mount supplies
 - Short rack ear
 - Long rack ear
 - Link bar to mount to similar receiver
 - Extension cables and connectors for front-mounting antennas
 - 8 rack ear screws
 - 4 rack mount screws with washers
 - 2 antenna hole plugs
- Protective bumpers
- 2 AA batteries (4 in combo systems)
- Power supply
- User guide

Vocalist system includes:

- Microphone Head ① (choice of SM58[®], SM86, Beta 58A[®], Beta 87A, or Beta 87C)
- SLX2 handheld transmitter ②
- Microphone clip ③

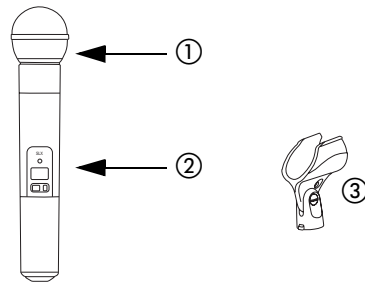

Lavalier, Headworn, and Instrument systems include:

- SLX1 bodypack transmitter
- Microphone (choice of WL93 ①, WL184 or WL185 ②, WH30 ③, or Beta 98H/C ④)

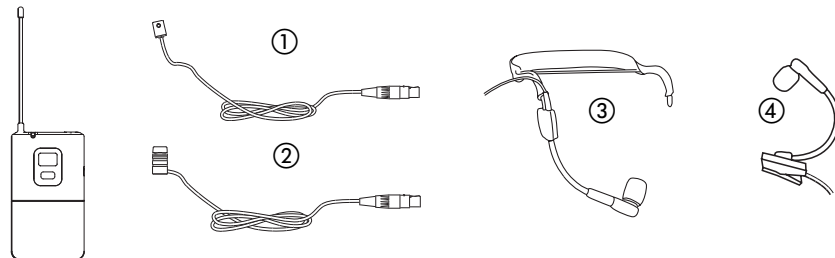

Guitar system includes:

- SLX1 bodypack transmitter
- 1/4" to mini 4-pin guitar cable

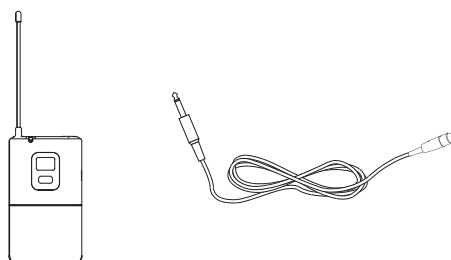

SLX4 Receiver Features

Front Panel

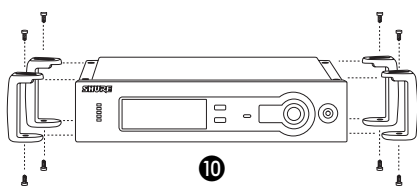
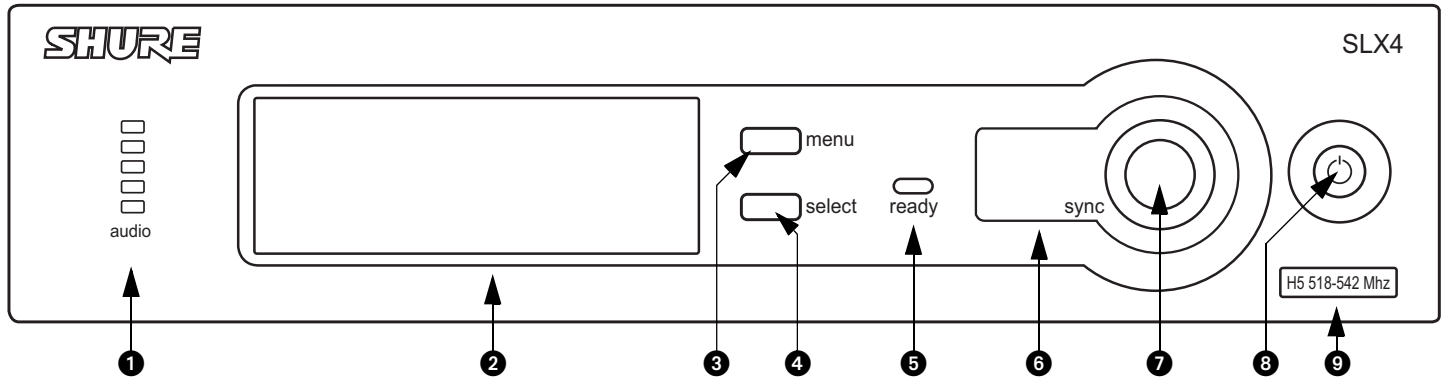

- 1** Audio LED
Indicates strength of incoming audio signal.
- 2** LCD panel
See "SLX Programming" on page 9.
- 3** Menu switch
Press to scroll through menu options. See "SLX Programming" on page 9.
- 4** Select switch
Press to select the currently displayed menu option. See "SLX Programming" on page 9.
- 5** Sync Ready Indicator
Illuminates when frequencies of receiver and transmitter are synchronized. See "SLX Programming" on page 9.
- 6** Infrared (IR) port
Broadcasts IR signal to transmitter to synchronize frequencies.
- 7** Sync Button
Press to initiate IR connection between receiver and transmitter. See "SLX Programming" on page 9.
- 8** On/Off switch
Tap to turn on, hold to turn off.
- 9** Frequency Band
Indicates the name and range of receiver frequency band.
- 10** Adding protective bumpers
Recommended if receiver is not rack mounted. Use supplied screws. For rack-mounting instructions, See "Rack-Mounting an SLX Receiver" on page 11.

Back Panel

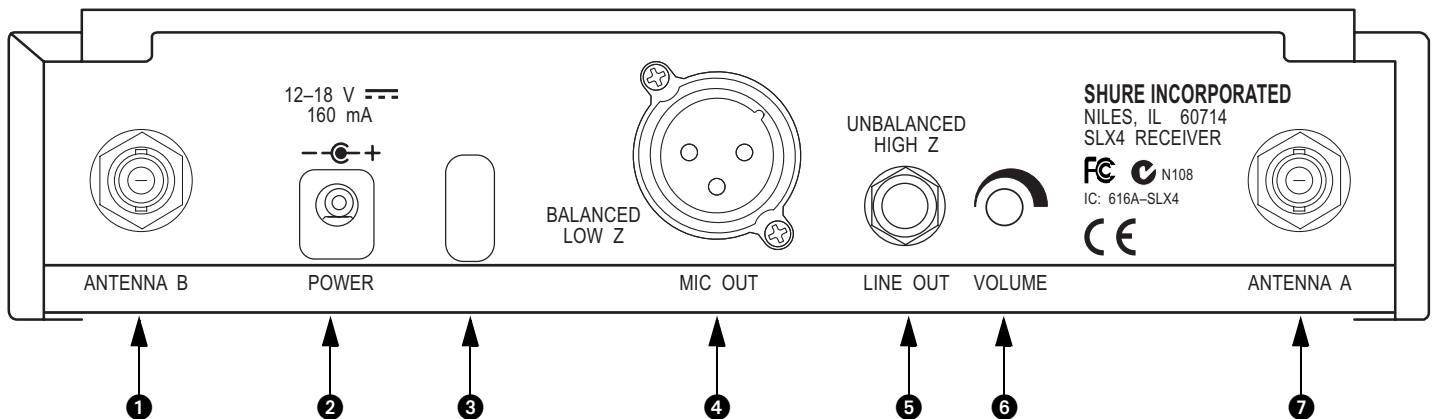

- 1** Antenna jack B
- 2** AC adapter jack
- 3** Adapter cord tie-off
Follow steps shown to secure cord to receiver body
- 4** XLR output jack
- 5** 1/4" output jack
- 6** Volume adjustment dial
Decreases receiver output level. See "Receiver Volume Control" on page 12.
- 7** Antenna jack A

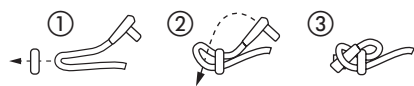

SLX2 Handheld Transmitter

Features

- ① Interchangeable microphone head (SM58 pictured)
- ② Power / Infrared (IR) / Mute indicator
 - Green: ready
 - Amber: mute on
 - Flashing red: IR transmission in process
 - Glowing red: battery power low
- ③ LCD screen
 - See "SLX1 and SLX2 Transmitter Programming" on page 10.
- ④ On-off / mute switch
 - Press and hold to turn on or off. Press and release to mute or unmute.

▶ **To avoid accidentally muting the microphone during a performance, lock the front panel while the microphone is in use.** See "Lock or Unlock Transmitter Settings" on page 10.

- ⑤ Select switch
 - See "SLX1 and SLX2 Transmitter Programming" on page 10.
- ⑥ IR port
 - Receives infrared beam to synchronize frequencies. **When using multiple systems, only one transmitter IR port should be exposed at a time.**

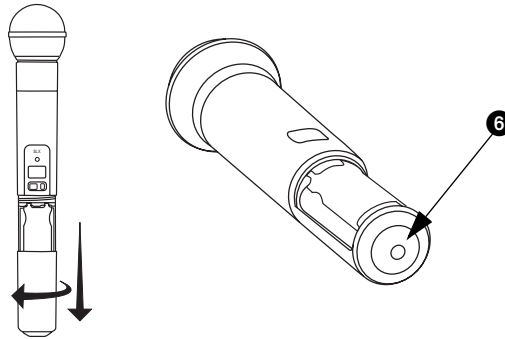
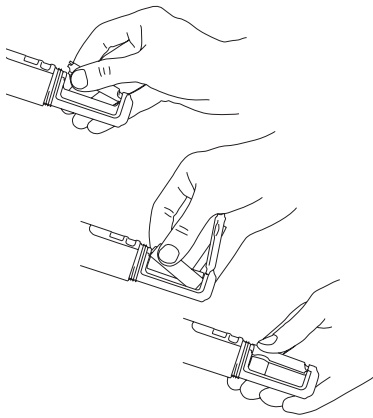
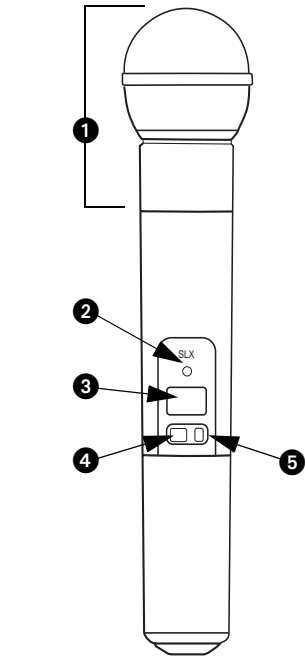

Changing Batteries

- Expected life for an Alkaline battery is approximately 8 hours.
- When the transmitter light glows red, the batteries should be changed immediately, as shown on the left.

Adjusting Gain

- Access the gain adjustment switch ① by unscrewing the head of the microphone.
- Two gain settings ② are available on the SLX2. Choose a setting appropriate for vocal volume and for the performing environment. Use the tip of a pen or a small screwdriver to move the switch.
 - **0dB:** For quiet to normal vocal performance.
 - **-10dB:** For loud vocal performance.

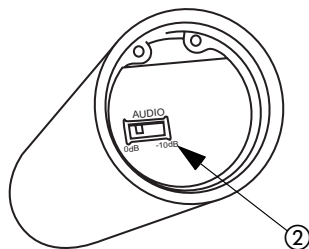
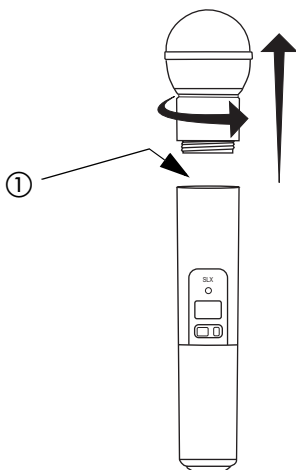

SLX1 Bodypack Transmitter

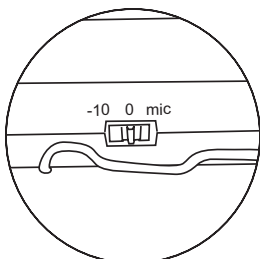
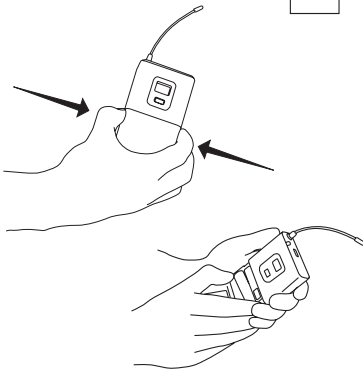
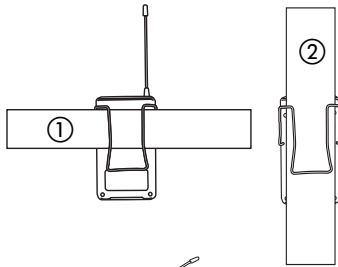
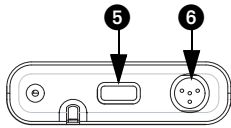
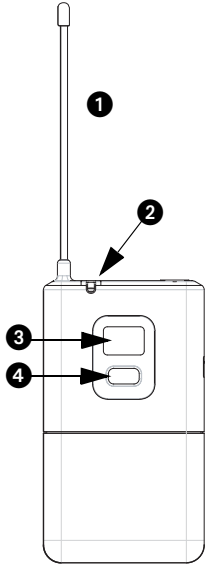

Features

- ❶ Antenna
- ❷ Power / Infrared (IR) / Mute indicator
Green: ready
Amber: mute on
Flashing red: IR transmission in process
Glowing red: battery power low
- ❸ LCD screen
See "SLX1 and SLX2 Transmitter Programming" on page 10.
- ❹ Select switch
See "SLX1 and SLX2 Transmitter Programming" on page 10.
- ❺ On-off / mute switch
Press and hold to turn on or off. Press and release to mute or unmute.
- ❻ 4-Pin Microphone Input Jack
- ❼ IR port
Receives infrared beam to synchronize frequencies. **When using multiple systems, only one transmitter IR port should be exposed at a time.**
- ❽ Gain adjustment switch (see below)

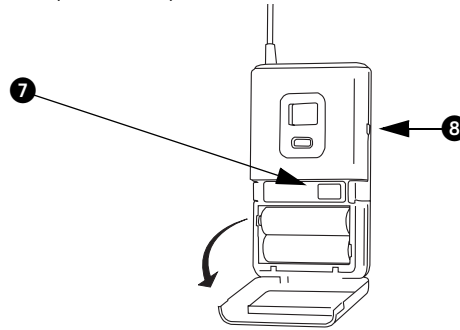

Wearing the Bodypack Transmitter

- Clip the transmitter to a belt ❶ or slide a guitar strap through the transmitter clip ❷ as shown.
- For best results, slide the transmitter until the belt ❶ is pressed against the base of the clip.

Changing Batteries

- Expected life for an Alkaline battery is approximately 8 hours.
- When the transmitter light glows red, the batteries should be changed immediately, as shown on the left.

Adjusting Gain

- Three gain settings are available on the SLX1. Choose the appropriate setting for your instrument.
 - **mic**: Microphone
 - **0**: Guitar with passive pickups
 - **-10**: Guitar with active pickups

Single System Setup

Follow these steps when using a single SLX system:



1. Automatic Frequency Selection ① menu ② select

Scans for an available channel and sets the receiver to that channel.

2. Automatic Transmitter Setup sync

Open the transmitter battery compartment to display the infrared (IR) port (see [page 6](#) and [page 7](#)).

With the IR port exposed to the receiver, press **sync**.

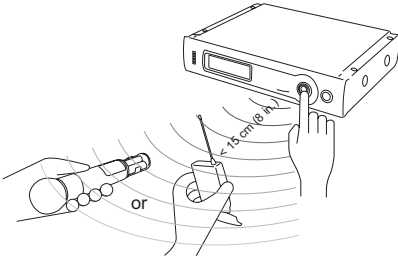

Multiple System Setup

Follow these steps when using multiple SLX systems in a single installation:

1. Turn all receivers **on** and all transmitters **off**.
2. Set all receivers to the same frequency group (see “[Group Selection](#)” on [page 9](#)).
3. Perform **Automatic Frequency Selection** from the Single System Setup section above.
4. Turn on the first transmitter.
5. Perform **Automatic Transmitter Setup** from the Single System Setup section above.

Repeat for each system.

► **Be sure that only one transmitter’s IR port is exposed when synchronizing a system.**

SLX Programming

Any option displayed on screen will generally “time out” after five seconds.

SLX4 Receiver Programming



Group Selection ① 2x menu ② select ③ sync

Allows manual selection of a frequency group. Pressing **select** increases the group number by one. When the correct frequency is displayed, either wait five seconds for the screen to time out, or press **sync**. For best results when operating multiple systems, set all systems to a single group; then set each system to a unique channel within that group.

For more information on frequency groups and channels, see [“Frequency Band Selection”](#) on page 2.



Manual Channel Selection ① 3x menu ② select ③ sync

Allows manual selection of a frequency channel. Pressing **select** increases the channel number by one. When the correct frequency is displayed, either wait five seconds for the screen to time out, or press **sync**.



Display Frequency ① 4x menu ② select

Displays the current frequency in Mhz for approximately 5 seconds. Press and hold to increase display length.



Lock or Unlock Receiver Settings select + menu

Hold down the **Select** key and press **Menu** to lock or unlock the receiver. When locked, the current receiver settings cannot be changed.



Antenna Status

Indicates RF activity. Only one antenna is active at any one time.



Transmitter Battery Status

Indicates a low transmitter battery charge.

SLX1 and SLX2 Transmitter Programming



Manually Select a Group and/or Channel



1. Press and hold the **select** button until the GROUP and CHANNEL displays begin to alternate.
2. To change the group setting, release the **select** button while GROUP is displayed ①. While GROUP is flashing, pressing **select** increases the group setting by one.
3. To change the channel setting, release the **select** button while CHANNEL is displayed ②. While CHANNEL is flashing, pressing **select** increases the channel setting by one.

Lock or Unlock Transmitter Settings



Press the **mute/power** and **select** buttons simultaneously to lock or unlock the transmitter settings. When locked, the current settings cannot be changed manually. **Locking the transmitter does not disable infrared synchronization.**

Battery Status



Indicates charge remaining in transmitter batteries.

Master List Indicator

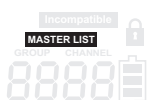

Indicates that a master list frequency is currently in use. No group or channel information is displayed.

Note: the transmitter cannot be used to change master list settings.

Incompatible Frequency Warning



The **incompatible** warning indicates that the receiver and transmitter are transmitting on different frequency bands. Contact your Shure retailer for assistance.

The Master Frequency List

Using the Master List



The “Master List” of frequencies should be accessed only by experienced users in situations which call for precise frequency selection. The “Master List” is a comprehensive index of all available frequencies in 25 kHz increments.

To access the Master List, hold down the **menu** button while powering on the SLX receiver.

Select Frequencies in the Master List



While FREQUENCY SELECT is flashing, the **select** button scrolls down through all available frequencies; the **menu** button scrolls up. Press and release to change the frequency in 25 kHz increments; press and hold to scroll quickly.

When the correct frequency is displayed, either wait five seconds for the screen to time out, or press **sync**.

Exit the Master List



To exit the Master List and return to normal system operations, press **menu**, then **select**.

Rack-Mounting an SLX Receiver

The supplied mounting hardware allows an SLX receiver to be mounted in any standard 19" audio equipment rack.

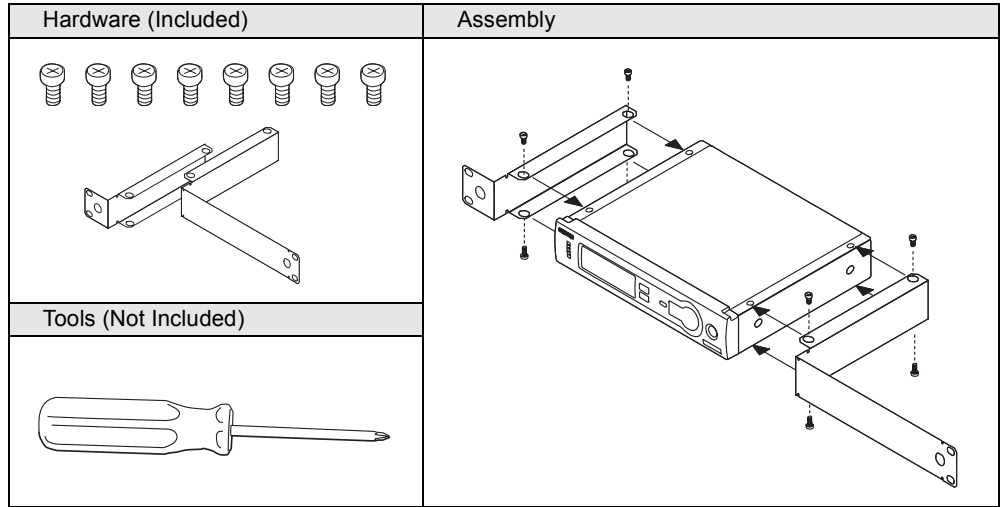

Rack-Mounting SLX Receivers

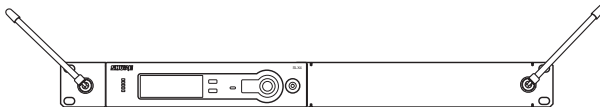
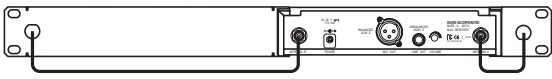
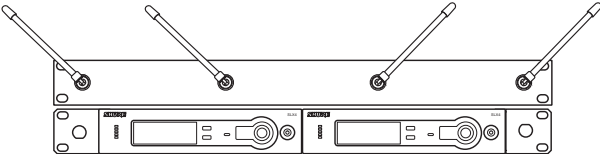
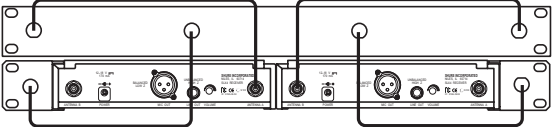
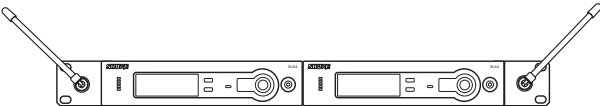
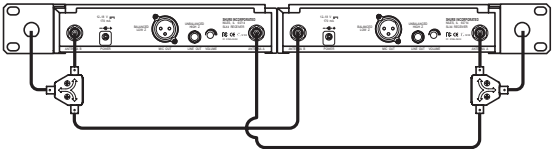
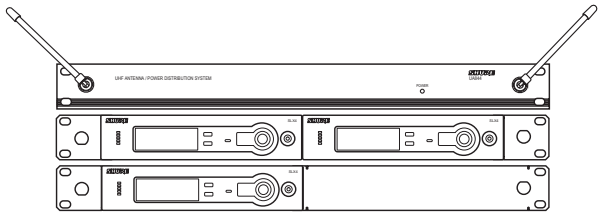
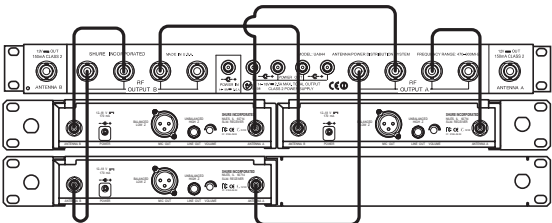
One Receiver	Wiring	Required Accessories
		<ul style="list-style-type: none"> • All accessories supplied
<h3>Two Receivers</h3> 		<ul style="list-style-type: none"> • 1 x UA440
<h3>Two Receivers with UA220 Antenna Splitter/Combiner Kit</h3> 		<ul style="list-style-type: none"> • 1 x UA221
<h3>Three or Four Receivers</h3> 		<ul style="list-style-type: none"> • 1 x UA844

Receiver Volume Control

The volume control dial should generally be left in the clockwise position. Turning the dial counter-clockwise decreases receiver output level.

If adjustments are necessary, use a small screwdriver to turn the dial.

Tips for Improving System Performance

- Maintain a line of sight between transmitter and antenna
- Avoid placing the receiver near metal surfaces or any digital equipment (CD players, computers, etc.)
- Secure the AC adapter cable to the receiver using the cable retainer loop
- If rack-mounting the receiver, front-mount the antennas as shown on [page 8](#).

Troubleshooting

Issue	Indicator Status	Solution
No sound or faint sound	Transmitter power light off	<ul style="list-style-type: none"> • Turn transmitter on (see pages 6 and 7) • Make sure the +/- indicators on battery match the transmitter terminals • Insert a fresh battery
	Receiver power light off	<ul style="list-style-type: none"> • Make sure AC adapter is securely plugged into electrical outlet and into DC input connector on rear panel of receiver • Make sure AC electrical outlet works and is supplying proper voltage
	Receiver display indicates antenna activity	<ul style="list-style-type: none"> • Press mute switch on transmitter (see pages 6 and 7) • Turn up receiver volume control (see page 5) • Increase transmitter gain switch setting (see pages 6 and 7) • Check cable connection between receiver and amplifier or mixer
	Receiver display indicates no antenna activity; transmitter and receiver power lights glowing	<ul style="list-style-type: none"> • Extend receiver antennas vertically • Move receiver away from metal objects • Check for line of sight between transmitter and receiver • Move transmitter closer to receiver • Check that receiver and transmitter are using the same frequency
	Transmitter power light glowing red	<ul style="list-style-type: none"> • Replace transmitter batteries
	Incompatible warning on transmitter	<ul style="list-style-type: none"> • The incompatible warning indicates that the receiver and transmitter are transmitting on different frequency bands. Contact your Shure retailer for assistance.
Distortion or unwanted noise bursts	Receiver display indicates antenna activity	<ul style="list-style-type: none"> • Remove nearby sources of RF interference (CD players, computers, digital effects, in-ear monitor systems, etc.) • Change receiver and transmitter to a different frequency (see page 9) • Reduce transmitter gain (see pages 6 and 7) • Replace transmitter battery • If using multiple systems, increase the frequency spread between systems (see page 9).
Distortion level increases gradually	Transmitter power light glowing red	<ul style="list-style-type: none"> • Replace transmitter batteries
Sound level different from cabled guitar or microphone, or when using different guitars		<ul style="list-style-type: none"> • Adjust transmitter gain (see pages 6 and 7) and receiver volume (see page 5) as necessary

Specifications

System

Frequency Range and Transmitter Output Level

Band	Range	Transmitter output
H5	518–542 MHz	35 mW/15 dBm
J3	572–596 MHz	35 mW/15 dBm
L4	638–662 MHz	35 mW/15 dBm
P4	702–726 MHz	35 mW/15 dBm
R5	800–820 MHz	20 mW/13 dBm
S6	838–865 MHz	10 mW/10 dBm
JB	806–810 MHz	10 mW/10 dBm
Q4	740–752 MHz	10 mW/10 dBm

NOTE: This Radio apparatus may be capable of operating on some frequencies not authorized in your region. Please contact your national authority to obtain information on authorized frequencies for wireless microphone products in your region.

Operating Range Under Typical Conditions

100m (300 ft.)

Note: actual range depends on RF signal absorption, reflection, and interference

Audio Frequency Response (+/-2 dB)

Minimum: 45 Hz
Maximum: 15 kHz

Total Harmonic Distortion (ref. +/-38 kHz deviation, 1 kHz tone)

0.5%, typical

Signal-to-Noise Ratio

>100 dB A-weighted

Operating Temperature Range

-18°C (0°F) to +57°C (+135°F)

Note: battery characteristics may limit this range

Transmitter Audio Polarity

Positive pressure on microphone diaphragm (or positive voltage applied to tip of WA302 phone plug) produces positive voltage on pin 2 (with respect to pin 3 of low impedance output) and the tip of the high impedance 1/4 inch output.

SLX1 Bodypack Transmitter

Audio Input Level

+2 dBV maximum at 0 dB gain position

Dimensions

108 mm H x 64mm W x 19 mm D (4.25 x 2.50 x 0.75 in.)

Weight

81 grams (3 oz.) without batteries

Housing

Molded ABS case

Power

2 "AA" size alkaline or rechargeable batteries

Battery Life

>8 hours

SLX2 Handheld Transmitter

Audio Input Level

+2 dBV maximum at minimum gain position

Dimensions (including SM58 cartridge)

254 mm x 51 mm dia. (10 x 2 in.)

Weight

290 grams (10.2 oz.) without batteries

Housing

Molded ABS handle and battery cup

Power

2 "AA" size alkaline or rechargeable batteries

Battery Life

>8 hours

SLX4 Receiver

Dimensions

42 mm H x 197 mm W x 134 mm D (1.65 x 7.76 x 5.28 in.)

Weight

0.8165 kg (1 lb. 13 oz.)

Housing

Molded ABS

Sensitivity

-105 dBm for 12 dB SINAD, typical

Audio Output Level (ref. +/- 38 kHz deviation with 1 kHz tone)

XLR connector (into 600 ohm load): +7 dBV (line), -13 dBV (mic)
1/4 inch connector (into 3000 ohm load): -2 dBV

Sensitivity

-105 dBm for 12 dB SINAD, typical

Image Rejection

>70 dB, typical

Power

12-18 Vdc at 150 mA, supplied by external power supply

Replacement Parts and Accessories

Optional Accessories

AC Adapter (120 VAC, 60 Hz)	PS20
AC Adapter (230 VAC, 50/60 Hz, Europlug)	PS20E
AC Adapter (230 VAC, 50/60 Hz, UK)	PS20UK
AC Adapter (100 VAC, 50/60 Hz)	PS20J
SM58 Head with Grille (SLX2/SM58)	RPW112
SM86 Head with Grille (SLX2/SM86)	RPW114
BETA 58 Head with Grille SLX2/BETA 58	RPW118
BETA 87A Head with Grille (SLX2/BETA 87A)	RPW120
BETA 87C Head with Grille (SLX2/BETA 87C)	RPW122
Matte Silver Grille (SLX2/SM58)	RK143G
Matte Silver Grille (SLX2/SM86)	RPM226
Matte Silver Grille (SLX2/BETA 58)	RK265G
Matte Silver Grille (SLX2/BETA 87A)	RK313
Matte Silver Grille (SLX2/BETA 87C)	RK312
Belt Clip	44A8030
1/4-Wave Antenna (518–752 MHz)	UA400B
1/4-Wave Antenna (748–865 MHz)	UA400

Antenna Combiners and Accessories

Antennas and receivers must be from the same band.

The supplied 1/4 wave antennas can be used when mounted directly to the UA844. If antennas are remote mounted, 1/2 wave antennas must be used.

Antennas and cables are for use with UA844, and cannot be used with stand-alone SLX receivers.

Passive Antenna/Splitter Combiner Kit (recommended for 2 receivers)	UA221
UHF Antenna Power Distribution Amplifier (recommended for 3 or more receivers)	
U.S.A.	UA844US
Europe	UA844E
UK	UA844UK
1/2 Wave Antenna Remote Mount Kit	UA500

Furnished Accessories

Microphone Stand Adapter (SLX2)	WA371
Zipper Bag (SLX1)	26A13
Zipper Bag (SLX2)	26A14
Short Rack Bar	53A8571
Long Rack Bar	53A8572
Link Bar	53A8443
Antenna extension cables (2)	95A9023

Optional Accessories

Carrying Case	WA610
Black Grille (SLX2/BETA 58)	RK323G
Black Grille (SLX2/BETA 87A)	RK324G

1/2 wave antennas (2)	
H5 Band	UA820H
J3 Band	UA820D
L4 Band	UA820L
P4, Q4 Bands	UA820B
R5, S6, JB Bands	UA820A
25' Antenna Cable	UA825
50' Antenna Cable	UA850
100' Antenna Cable	UA100

Microphone Specifications

WL183

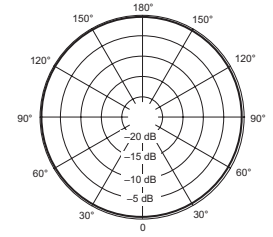
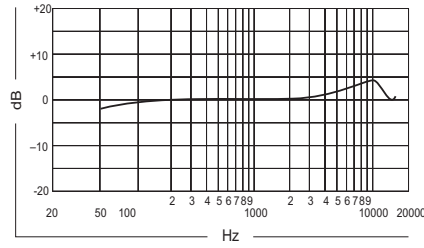

WL184

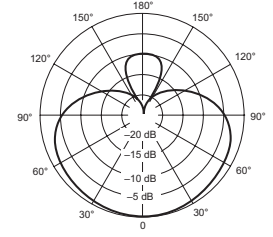
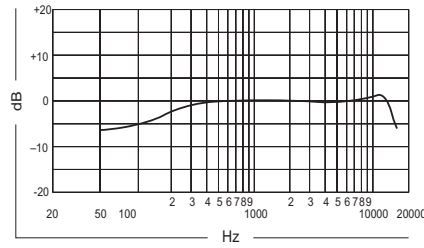

WL185

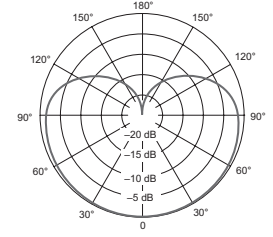
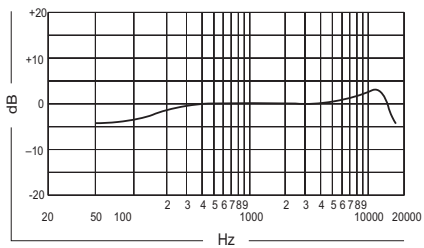

WL50

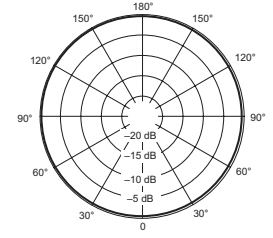
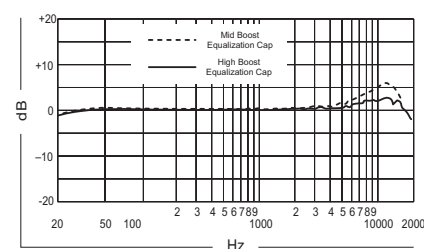

WL51

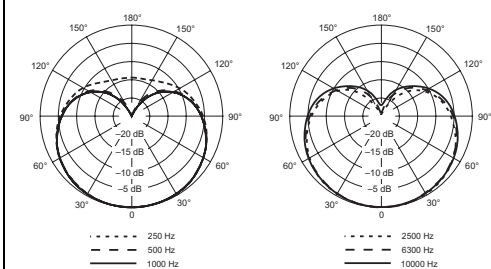
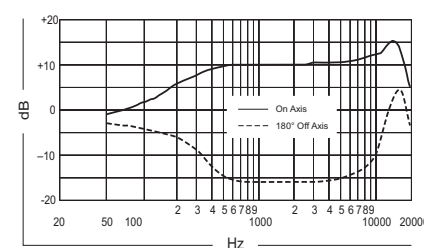

Microphone Specifications

WH20

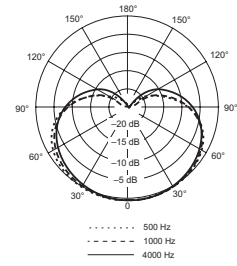
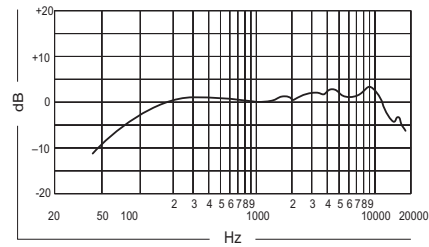

WH30

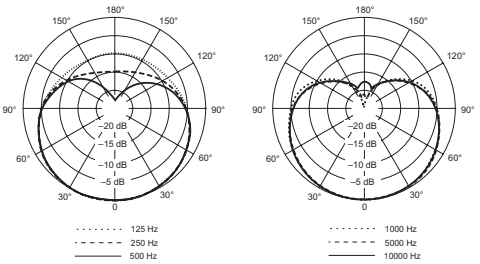
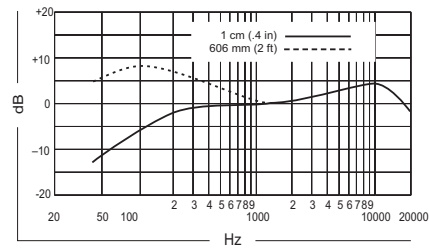

BETA98H/C

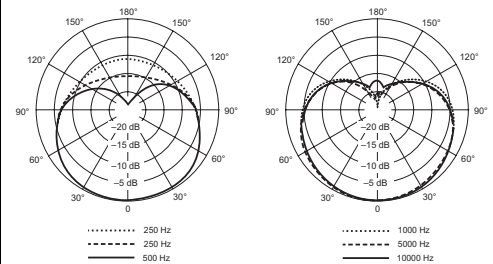
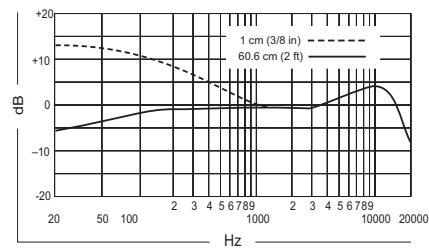

SM58

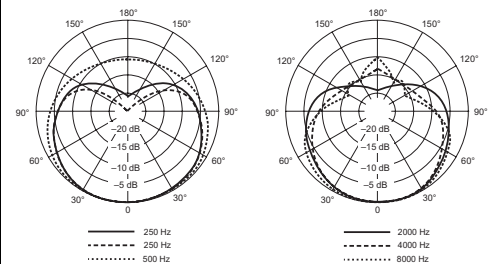
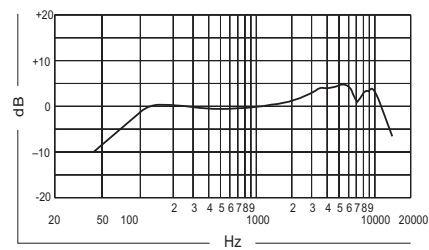

SM86

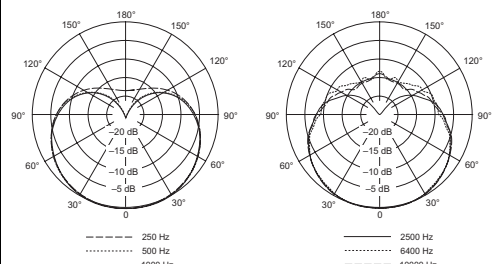
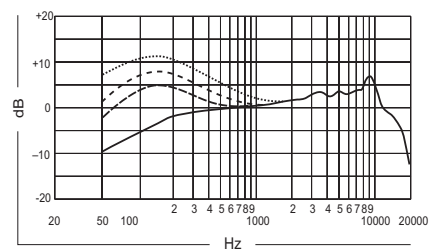

Microphone Specifications

BETA58

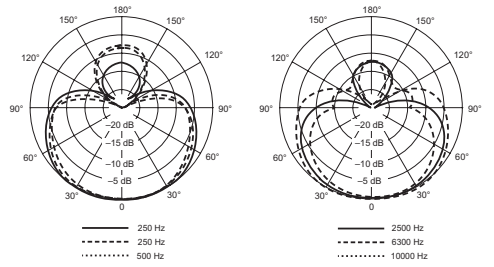
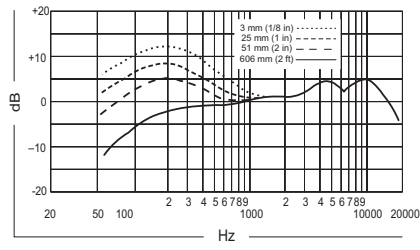

BETA87A

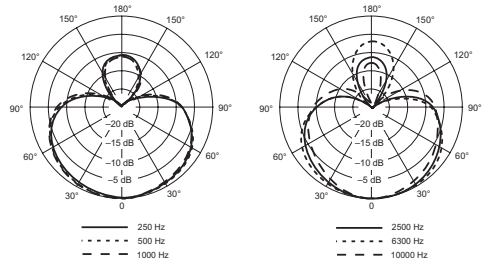
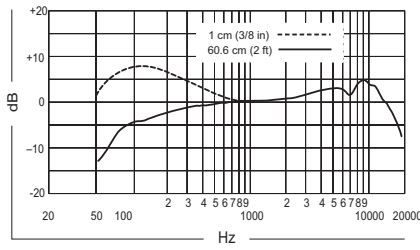

BETA87C

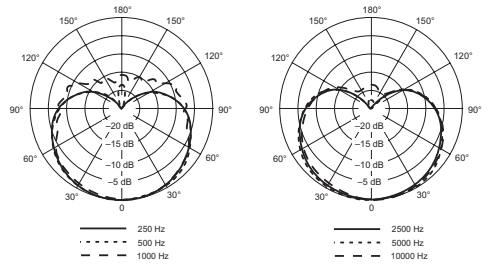
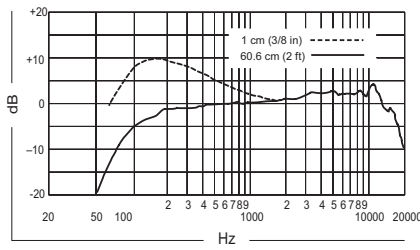

Frequency Ranges

H5: 518,000–542,000 MHz

	Group 1	Group 2	Group 3	Group 4	Group 5	Group 6
1	518.200	519.750	518.300	520.725	519.050	518.600
2	520.200	521.975	519.775	522.100	520.475	520.075
3	523.200	523.200	520.875	524.250	521.600	521.250
4	525.425	524.850	522.525	525.750	525.525	525.275
5	527.000	526.950	523.800	526.850	527.600	527.250
6	529.675	528.425	527.050	528.525	530.225	531.125
7	531.575	530.325	528.875	529.775	531.475	532.950
8	533.050	533.000	532.750	532.400	533.150	536.200
9	535.150	534.575	534.725	534.475	534.250	537.475
10	536.800	536.800	538.750	538.400	535.750	539.125
11	538.025	539.800	539.925	539.525	537.900	540.225
12	540.250	541.800	541.400	540.950	539.275	541.700

J3: 572,000–596,000 MHz

	Group 1	Group 2	Group 3	Group 4	Group 5	Group 6
1	572.200	573.750	572.300	574.725	573.050	572.600
2	574.200	575.975	573.775	576.100	574.475	574.075
3	577.200	577.200	574.875	578.250	575.600	575.250
4	579.425	578.850	576.525	579.750	579.525	579.275
5	581.000	580.950	577.800	580.850	581.600	581.250
6	583.675	582.425	581.050	582.525	584.225	585.125
7	585.575	584.325	582.875	583.775	585.475	586.950
8	587.050	587.000	586.750	586.400	587.150	590.200
9	589.150	588.575	588.725	588.475	588.250	591.475
10	590.800	590.800	592.750	592.400	589.750	593.125
11	592.025	593.800	593.925	593.525	591.900	594.225
12	594.250	595.800	595.400	594.950	593.275	595.700

L4: 638,000–662,000 MHz

	Group 1	Group 2	Group 3	Group 4	Group 5	Group 6
1	638.200	639.750	638.300	640.725	639.050	638.600
2	640.200	641.975	639.775	642.100	640.475	640.075
3	643.200	643.200	640.875	644.250	641.600	641.250
4	645.425	644.850	642.525	645.750	645.525	645.275
5	647.000	646.950	643.800	646.850	647.600	647.250
6	649.675	648.425	647.050	648.525	650.225	651.125
7	651.575	650.325	648.875	649.775	651.475	652.950
8	653.050	653.000	652.750	652.400	653.150	656.200
9	655.150	654.575	654.725	654.475	654.250	657.475
10	656.800	656.800	658.750	658.400	655.750	659.125
11	658.025	659.800	659.925	659.525	657.900	660.225
12	660.250	661.800	661.400	660.950	659.275	661.700

Frequency Ranges

P4: 702,000–726,000

	Group 1	Group 2	Group 3	Group 4	Group 5	Group 6	Group 7	Group 8
1	702.200	703.750	703.650	702.750	703.750	702.100	704.775	702.300
2	704.200	705.975	705.650	704.500	705.750	704.025	706.225	704.975
3	707.200	707.200	708.650	705.750	708.250	705.500	710.500	706.775
4	709.425	708.850	710.875	708.250	711.750	708.500	712.025	709.100
5	711.000	710.950	712.450	711.250	714.500	710.100	714.225	710.300
6	713.675	712.425	715.125	712.500	715.750	712.025	716.900	712.225
7	715.575	714.325	717.025	715.250	718.750	713.500	718.500	714.775
8	717.050	717.000	718.500	718.750	721.250	717.300	720.775	716.700
9	719.150	718.575	720.600	721.250	722.500	725.300	725.300	724.000
10	720.800	720.800	722.250	723.250	724.250			725.900
11	722.025	723.800	723.475					
12	724.250	725.800	725.700					

	Group 9	Group 10	Group 11	Group 12	Group 13	Group 14	Group 15	Group 16
1	703.000	702.200	710.200	718.200	702.550	702.100	702.700	702.500
2	706.025	703.300	711.300	719.300	705.600	704.700	704.700	705.500
3	708.000	704.700	712.700	720.700	707.500	710.300	709.450	707.000
4	710.300	705.800	713.800	721.800	709.000	712.400	711.500	712.200
5	712.225	707.675	715.675	723.675	711.500	714.000	714.500	714.100
6	716.000	708.775	716.775		715.100	716.500	716.550	716.400
7	717.100				717.000	719.400	719.900	719.500
8	719.000				720.000	721.300	722.000	722.200
9	720.225				723.500		724.700	
10	722.775				725.900		725.900	
11	724.700							

R5: 800,000–820,000, 800,100–819,000

	Group 1	Group 2	Group 3	Group 4	Group 5	Group 6	Group 7
1	801.250	801.225	800.950	800.525	801.475	800.600	800.650
2	804.825	804.800	802.950	801.925	803.025	802.050	803.125
3	806.975	806.950	804.325	803.650	805.800	804.275	804.450
4	808.800	808.775	806.425	804.850	806.950	805.750	806.150
5	810.325	810.300	808.050	807.400	809.125	806.850	807.250
6	811.550	811.525	809.275	808.525	810.575	808.550	808.725
7	813.175	813.150	810.800	810.275	811.725	809.875	810.950
8	815.275	815.250	812.625	811.550	813.800	812.350	812.400
9	816.650	816.625	814.775	813.775		813.450	813.500
10	818.650	818.625	818.350				
11	819.750	819.800	819.775				

	Group 8	Group 9	Group 10	Group 11	Group 12	Group 13	Group 14
1	806.000	806.025	801.400	800.900	801.200	803.850	806.150
2	807.100	807.425	808.300	802.100	803.800	807.000	811.650
3	808.500	808.525	816.400	806.200	805.900	809.700	814.400
4	809.600	810.400		809.300	807.000	811.050	816.500
5	811.475	811.500		814.100	809.200	813.900	817.450
6	812.575	812.900		816.100	811.700	816.500	819.300
7	813.975	814.000		817.200		817.600	
8				819.600		819.500	



Frequency Ranges

S6: 838,000–865,000

	Group 1	Group 2	Group 3	Group 4	Group 5	Group 6	Group 7	Group 8
1	838.200	838.150	838.550	854.200	855.475	855.075	854.750	854.750
2	841.450	839.375	839.775	855.300	857.425	857.775	855.850	855.850
3	843.275	841.300	841.700	856.700	860.600	860.725	857.250	857.250
4	846.225	842.475	842.875	857.800			858.350	858.350
5	847.350	846.400	846.800	859.675			860.225	860.225
6	850.125	848.025	848.425	860.775			861.325	861.325
7	852.575	850.025	850.425					
8	854.575	852.475	852.875					
9	856.200	855.250	855.650					
10	860.125	856.375	856.775					
11	861.300	859.325	859.725					
12	863.225	861.150	861.550					
13	864.450	864.400	864.800					

	Group 9	Group 10	Group 11	Group 12	Group 13	Group 14	Group 15
1	854.425	863.200	838.200	838.900	838.100	838.700	838.400
2	855.525	864.500	839.900	842.600	841.100	842.800	840.600
3	857.400		841.000	845.900	842.700	844.800	842.100
4	858.500		842.375	847.500	847.000	846.300	844.700
5	859.900		844.400	848.600	849.200	847.400	846.600
6	861.000		846.100	850.100	850.400	849.200	848.100
7			847.350	852.100	852.500	851.300	850.700
8			849.400	853.300	854.100		851.850
9			851.800	855.100	855.300		853.700
10			853.200	857.210			
11				858.650	KE ch's	KE ch's	S5 ch's
12				859.800	856.950	852.450	855.275
13				861.900	859.375	854.900	856.175

Regulatory Information

SLX1 & SLX2 Transmitters: Certified to FCC Part 74 (FCC ID: "DD4SLX1" & "DD4SLX2"). Certified by IC in Canada under RSS-123 and RSS-102 ("IC: 616A-SLX1" and "IC: 616A-SLX2"). This class B digital apparatus complies with Canadian ICES-003. Meets the essential requirements of the European R&TTE Directive 99/5/EC (ETSI EN 300-422 Parts 1 & 2, EN 301 489 Parts 1 & 9) and are eligible to carry the CE marking.  0682 

SLX4 Receiver: Authorized under Declaration of Conformity (DoC) provision of FCC Part 15. Certified under Industry Canada to RSS-123 ("IC: 616A-SLX4"). This class B digital apparatus complies with Canadian ICES-003. Meets the essential requirements of the European R&TTE Directive 99/5/EC (EN 301 489 Parts 1 & 2, EN 300 422 Parts 1 & 2) and is eligible to carry the CE marking. 

Conforms to Australian EMC requirements and is eligible for C-Tick marking.  N108

PS 20 Series Power Supplies: Conform to Safety Standard IEC 60065. PS20E and PS20UK are eligible to bear CE marking.

European Countries and Frequencies