

SHURE®

Service Manual

UC1 / UC1L Body-Pack UHF Transmitter

Characteristics

General

The Shure UC1/UC1L Body-Pack Transmitter is microprocessor-controlled, operating in the 774 – 862 MHz frequency range. The UC1/UC1L is used in mid-level installed sound, rental, and concert sound applications. Six frequency range variations are available.

Controls and Connectors

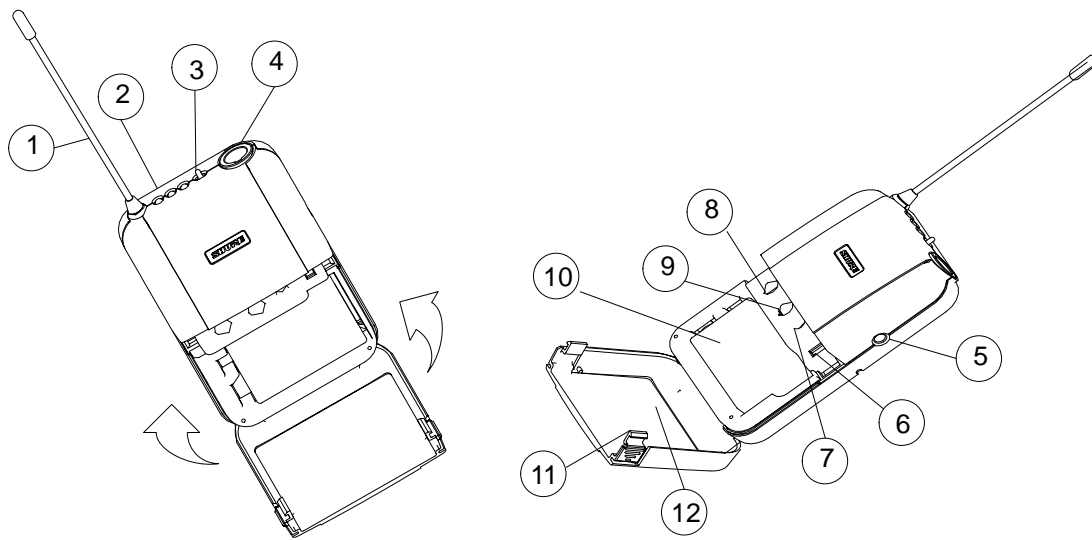

- | | |
|---|--------------------------------|
| 1. Antenna | 7. Audio Gain Control |
| 2. Power/Battery Fuel Gauge LEDs | 8. Group Rotary Switch |
| 3. Power ON/OFF Switch | 9. Channel Rotary Switch |
| 4. Input Connector | 10. Battery Compartment |
| 5. Rf/Audio Mute Switch Input Connector | 11. Battery Cover Release Tabs |
| 6. Input Attenuation Control | 12. Battery Compartment Cover |

Figure 1. UC1 Controls and Connectors

Service Note: Shure recommends that all service procedures be performed by a Factory-Authorized Service Center or that the product be returned directly to Shure Brothers Inc.

Circuit Description

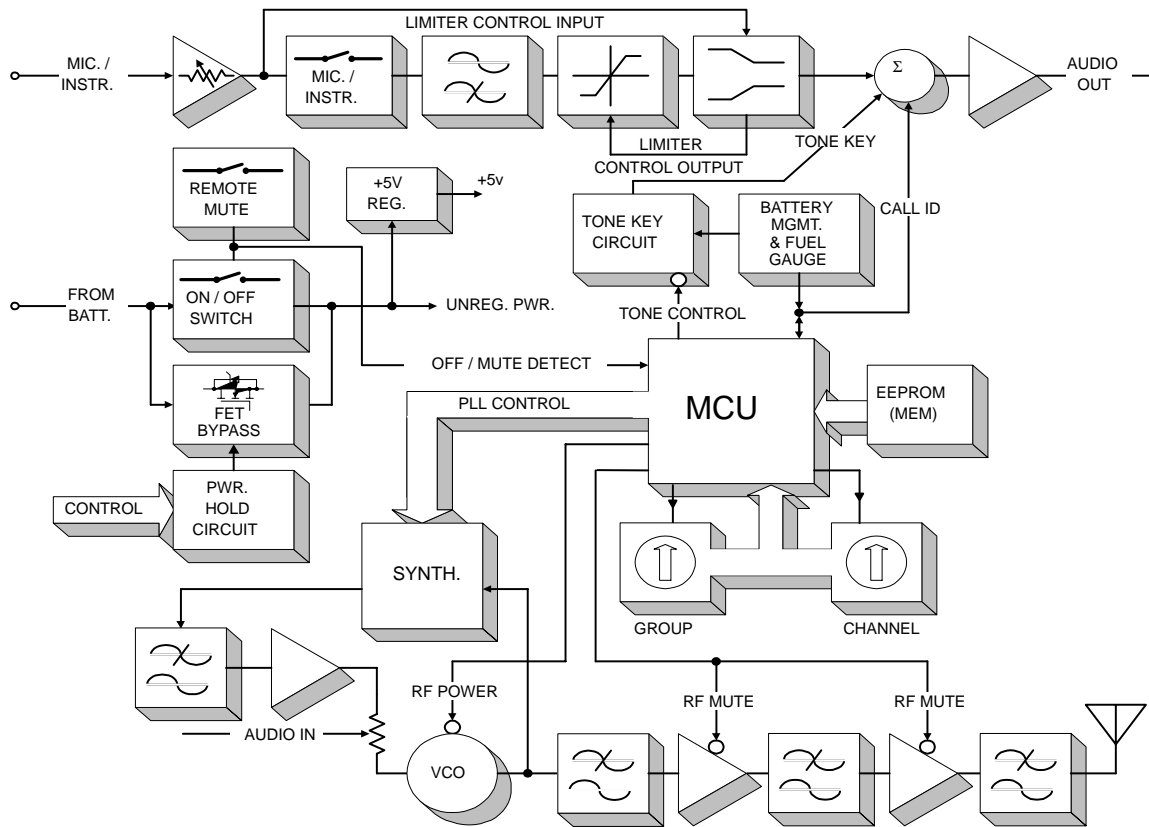

Figure 2. UC1 Circuit Block Diagram

Audio Section

Domestic Models

The audio signal enters the audio board at J204, pin 1. The signal then enters a switchable 20 dB pad made up of SW203, R203, R204, C204, and C206. The back-to-back diodes, U206, are used to keep the op-amp from snapping to the rail and reverse-phasing when the maximum input voltage range is exceeded.

The signal is ac-coupled through C205 into a 40 dB (30 dB for J frequencies) user-adjustable gain stage around amplifier U2. This gain stage is externally accessible to the user. Due to its topology, it is a unique stage because it is non-inverting and allows for a gain less than unity. Resistors R205 and R207 set up a half-supply bias, and R206 sets the ac input impedance.

The amplified audio signal then passes through a pre-emphasis network before entering the compression stage. R221, R222, C215, and C216 set up two corners for the pre-emphasis network. The pre-emphasis network feeds the NE575 compander, U203, which utilizes

an external amplifier, U202B. U203 performs a 2:1 logarithmic compression of the audio signal.

Transistors Q201 and Q202, with crystal Y201, form the tone key oscillator circuit that provides a stable, continuous 32.768 kHz sine wave. Q204 buffers the tone key signal before it is added to the audio signal. The tone key signal is used in the receiver to provide audio output only when the tone key signal is present in the transmitted signal. If the tone key or the transmitter is turned off, the receiver is muted.

Q211 acts as a switch for toggling the tone key ON/OFF. It is controlled from the microprocessor, via the TONEMUTE0 signal. The tone key signal, along with the processed audio signal, is then fed to a summing amplifier, U201A. After passing through the ac coupling capacitor, C240, the signal is then fed to the rf module.

The battery meter circuit is comprised of comparator U208 and LEDs D201, D202, D203, and various resistors. When the battery circuit is less than 6.5 Vdc, the output of U208, pin 13, changes low, the red LED illuminates, and the tone-key level increases. The receiver then utilizes the amplitude of the tone-key to indicate that the transmitter battery is low.

A 9 Vdc battery provides power to the audio printed circuit board (pcb) through switch SW202. FET Q217 provides electrical reverse battery protection. 9 Vdc enters U205, a low-dropout 5 Vdc regulator, and gives a clean regulated 5 Vdc supply to run the audio circuitry.

ETSI Models

This transmitter uses the same board as the non-ETSI system, except that it requires a different topology and different parts.

A limiter is inserted between the pre-emphasis and the compressor to limit the occupied bandwidth. The buffer after the gain stage, U201A, is now an inverter with pre-emphasis and 20 dB of attenuation.

Previously bypassed, the expander side of U203 is now activated and used as a limiter. A sample of the audio is taken from the limiter output (U203, pin 6) and sent to a control circuit which detects signals from a limiting threshold.

The comparator then sends a control signal to U202, pin 5, which clamps the signal.

Rf Section

Processed audio enters R149, an internal potentiometer that is adjusted for 45 kHz deviation (100% modulation for UA, MA, and MB frequencies), with a -7.2 dBV (0.355 Vrms) 1 kHz tone at the output of the front audio stage (U201, pin 1). For KK frequencies, R243 is adjusted for 40 kHz deviation. For JB frequencies, R149 is adjusted for 5 kHz deviation with -63.2 dBV, 1 kHz tone at the input to the transmitter.

Shure UC1 Body-Pack UHF Transmitter

The audio is then fed to the tuning voltage pin of the voltage-controlled oscillator (VCO) and modulates the carrier directly.

Using a phase-locked loop (PLL) frequency synthesized system eliminates the need for multiplier stages and results in a much higher degree of spectral purity. The VCO is shielded to prevent external rf fields from affecting its operation.

Regulated 5 Vdc power is provided to ensure frequency stability with changes in battery voltage.

The VCO can tune from 782 MHz to 810 MHz with a 1 Vdc to 4 Vdc tuning voltage range; different VCOs are required for MB and KK frequency models. At the output of the VCO, the rf signal splits into two paths.

The output of the VCO is coupled by C134 to the frequency control pin of the synthesizer, U104, pin 8. The internal circuitry of the synthesizer divides the signal, as necessary, to the desired reference frequency of 125 kHz. The synthesizer contains a reference oscillator circuit operating from a 4.0 MHz quartz crystal, Y101, that is adjusted by trimmer C123. The transmitter output frequency is user-selectable in 125 kHz increments, from 782 MHz to 806 MHz. Frequency range and increment size vary for each model.

Frequency selection is made via microprocessor U101, which interfaces the user by means of the mode/select switches. The output of the synthesizer is a series of pulses which are integrated by a passive loop filter, R121, C130, R122, C129, C130, R123, and C132, to produce a control voltage signal. The control voltage signal is then connected to the VCO through amplifier U106A, which is used to isolate the PLL filter from the audio modulation signals.

The VCO output is also coupled to an rf power amplifier through a resistive pad consisting of R127, R128, R129, and R130. The signal is then low-pass filtered through U107. The signal is coupled through C144.

Transistor Q102 acts as an rf pre-amplifier stage with typically 8 dB of gain. R131, R132, and R133 provide dc bias to Q102. C145, C146, C147, C149, C150, and L111 are used to decouple the rf off the emitter of Q102, Vcc, and +9 Vdc supply voltages.

C152 couples the output of Q102 to low-pass filter U108. The signal is then low-pass filtered through U108, and then coupled through C157.

Q104 acts as an rf amplifier stage with typically 16 dB of gain. L110, R136, R137, and R138 provide dc bias to Q102. C160, C161, C162, C163, C164, C165, and L114 are used to decouple the rf off the emitter of Q104, Vcc, and +9 Vdc supply voltages.

L115 and C167 match the output of Q104 to low-pass filter U109. The signal is coupled through C173 to the output antenna, W101.

The transmitter can deliver a maximum of +17 dBm (50 mW) to the 50Ω antenna. During transmitter power-up and frequency selection, the rf power is muted by bringing the gate of Q103 and Q105 high. The RFUNMUTE signal is 5 Vdc. This provides approximately 45 dB rf attenuation until the PLL has locked.

The transmitter is unmuted by bringing the gate low (RFUNMUTE). During transmitter power OFF conditions, the rf power is first muted by bringing the base of Q103 and Q105 high. When the rf is muted this way, the carrier signal of the transmitter is not allowed to drift off frequency during power ON or OFF conditions.

When the external mute switch is closed, the ring and sleeve on the jack are connected, or the tip and sleeve can be connected, depending on how the switch is wired.

If the tip is connected to the sleeve, this grounds the IRQ signal line that is connected to the microprocessor. Then, the 33 kHz tone key signal is muted (TONEMUTE1). The transmitter rf power is muted by bringing the base of Q103 and Q104 high (RFMUTE1). Finally, the rf power is then turned off via the RFOFF1 signal. This is done by reducing the Vcc line to the VCO and the last rf amps.

If the ring is connected to the sleeve, this grounds the TKMUTE1. The TKMUTE1 grounds Q4 at the output of the tone key oscillator circuit. This mutes the audio signal immediately.

Transmitter Display Board

UHF Body-Pack Transmitter Digital Section

The digital section contains several circuitry blocks.

Microcontroller Section

The microcontroller section consists of a U101 microcontroller. The rotary switches indicate the UHF frequency group and channel. A 4.000 MHz oscillator provides the operating frequency to the microcontroller. The oscillator circuit includes C117, C118, and Y102. U103, R106, and C120 form the reset circuit. U103 is the reset IC that resets the U101 microcontroller if the 5 Vdc normal operating voltage falls below 4.3 Vdc. R115 and C119 form the power supply filter circuit.

Memory Section

The memory section consists of U102, a non-volatile Electrically Erasable / Programmable Read Only Memory (EEPROM) that stores the mapping of compatible groups and channels. The microcontroller serially communicates with this part via data and clock lines to read the frequency corresponding to the group and channel position. Ability to write to this memory occurs during factory programming only.

During normal usage, this memory is used as a look-up table only. Additional detail about the contents of EEPROM is covered in the following sections.

R103 and R108 resistors allow the clock and data lines to be driven independently of the microcontroller port pin states during in-circuit programming of EEPROM.

Battery Management Section

The microcontroller provides for low battery shutdown. The shutdown threshold is $1.88 \text{ Vdc} \pm 10\%$. A voltage lower than the shutdown threshold on pin 17 of the U101 microcontroller shuts down the transmitter. Resistors R104 and R105 divide down the battery voltage for the microcontroller. A battery voltage of less than 5.65 Vdc shuts down the transmitter.

This auto shutdown disables the audio tone key mix, mutes the rf power output, and power downs the rf output amplifier section. The current draw from a 9 Vdc battery in this state is 45 mA, and the battery fuel gauge is functional. Turning off the power switch must completely shut off the transmitter.

The audio circuit description provided the battery fuel gauge circuit description.

Rotary Switches for Frequency Selection

A 10-position Group switch, S101, and a 16-position Channel switch, S102, select the transmitter frequency. Both rotary switches share the same U101 microcontroller port pins, 3 through 6, for a multiplexed switch read operation.

Pins 7 and 8 of the U101 microcontroller select the individual switches. Resistors R109 through R112 are the pull-ups for the switch position read. Diode packs D101 through D104 isolate the switches during a multiplexed read operation.

The multiplexed switch read system does not allow switch change detection based on interrupts. Also, the switches cannot be constantly scanned to determine changes, because the scanning frequency being in audio range is difficult to filter out.

In a steady state, the switch selector common pins are inputs to the U101 microcontroller pins 7 and 8. Pins 3 through 6 are outputs. In this state, pins 4, 5, and 6 are held low, while pin 3 is held high. This forces a logic high level on the switch selector pins if the switches are set on odd positions. If the switches are set on even positions, the contact on pin 1 is open from the switch common pin, and the pull-down resistors, R114 and R115, force the logic low to pins 7 and 8 of U101.

Any switch change is made by a state toggle from odd to even, or vice versa. Only this change can be detected and is followed by a multiplexed switch read. In this case, U101 pins 7 and 8 become selectively grounded outputs to read the selected switch's state on pins 3 through 6.

A multiplexed switch read is preceded by tone key and rf mutes. This mutes the audio in the receiver to allow a quiet change to another frequency.

Power Switch and Remote Mute Switch Interface

When a transmitter is turned off, the PWRDN1 signal goes to logic low on U101, pin 19. The same signal is also forced low when a remote mute switch closes the tip contact to the sleeve ground.

The microcontroller treats both of these events in a similar manner. It immediately disables the tone key, and the power hold circuit automatically kicks in to bypass the power switch. Followed by 500 msec. of delay, the rf is muted and also turned off.

The power hold circuit is also disabled at this point. If it is the power off condition, then the transmitter is shut off. Otherwise, it is the remote mute condition, and the transmitter waits here for unmute to occur. PWRDN1 is pulled up back to logic high level when unmute occurs.

The rf section repowers and is unmuted, followed by tone key enable to completely recover from the remote mute condition. When a remote mute switch closes the ring contact to the sleeve ground, the TKMUTE1 signal goes to a logic low that immediately mutes the audio.

Notes

This page intentionally left blank.

Functional Test

Verify operation and reported malfunction, referring to the product *User Guide* for a description of the unit as well as information on its operation, troubleshooting, and technical data.

Disassembly and Assembly



! CAUTION !

Observe precautions when handling this static-sensitive device.

Disassembly

1. Open the battery compartment and remove the battery.
2. Remove the belt clip.
3. With the battery compartment open, remove the four screws from the back of the case.
4. Lift the top half of the transmitter case away to expose the printed circuit boards (pcbs).
5. Lift the pcbs out of the transmitter case.

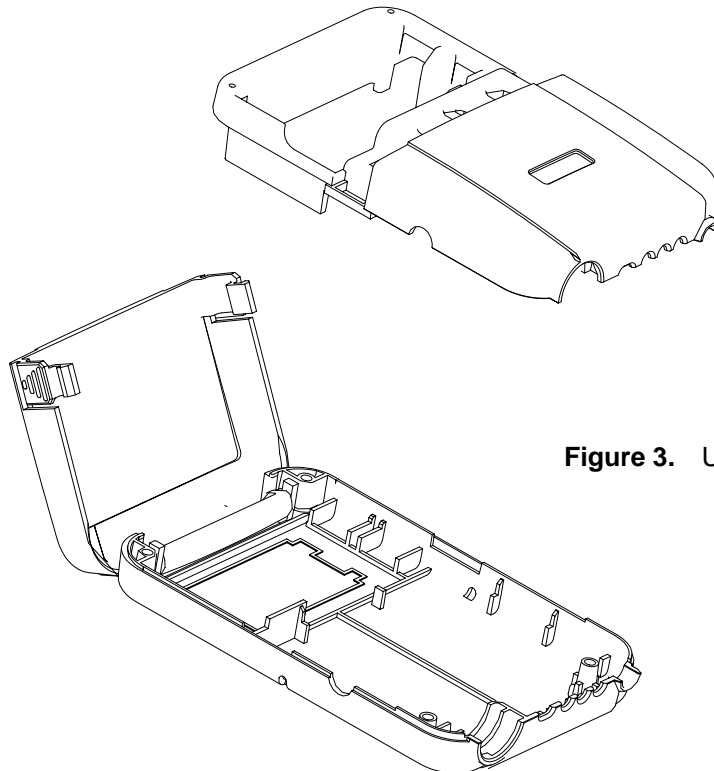

Figure 3. UC1 Disassembly

Reassembly

After completing all repairs and alignment, reassemble the UC1:

1. Place the printed circuit boards back into the case, making sure the multi-pin connectors on the board mate and the TINI QG/ LEMO connector is seated correctly.
2. Reassemble the transmitter by performing the disassembly steps in reverse order.

Service Procedures

Measurement Reference

dBu is a measure of *voltage*, and dBm is a measure of *power*.

For example, the HP8903 should be labeled dBu instead of dBm because it is a voltage measurement. These two terms are often used interchangeably even though they have different meanings.

Audio levels in dBu are marked as dBm on the HP8903.

dB Conversion Chart	
0 dBV	= 2.2 dBu
0 dBu	= 0 dBm, assuming the load = 600 Ω

Test Equipment

Most test equipment needed is described in the Shure *Wireless Service Equipment Manual*. The following test equipment (or approved equivalent) is also needed.

Table 1
Test Equipment

Equipment Type	Model
Audio analyzer	*Hewlett-Packard 8903B
Digital multimeter	Fluke 87
Cable	PT1843
Frequency counter	Hewlett-Packard 53181A
Rf signal generator	Hewlett-Packard 8656B
Spectrum analyzer	Hewlett-Packard 8590L
Shure UC4 receiver	Shure UC4

*Audio levels in dBu are marked as dBm on the HP8903B.

Test Equipment Set-Up

The alignment procedure is sequential and does not change, unless specified.

1. Use RG58 or any other low-loss, 50 Ω test cables for all rf connections. For JA, JB frequencies, use an adapter cable.
2. Keep the test cables as short as possible.
3. Include the insertion loss of the cables and the connectors for all rf measurements.
4. Dc voltages are present at most rf test points. Use dc blocks to protect the test equipment, if necessary.

Test Set-Up

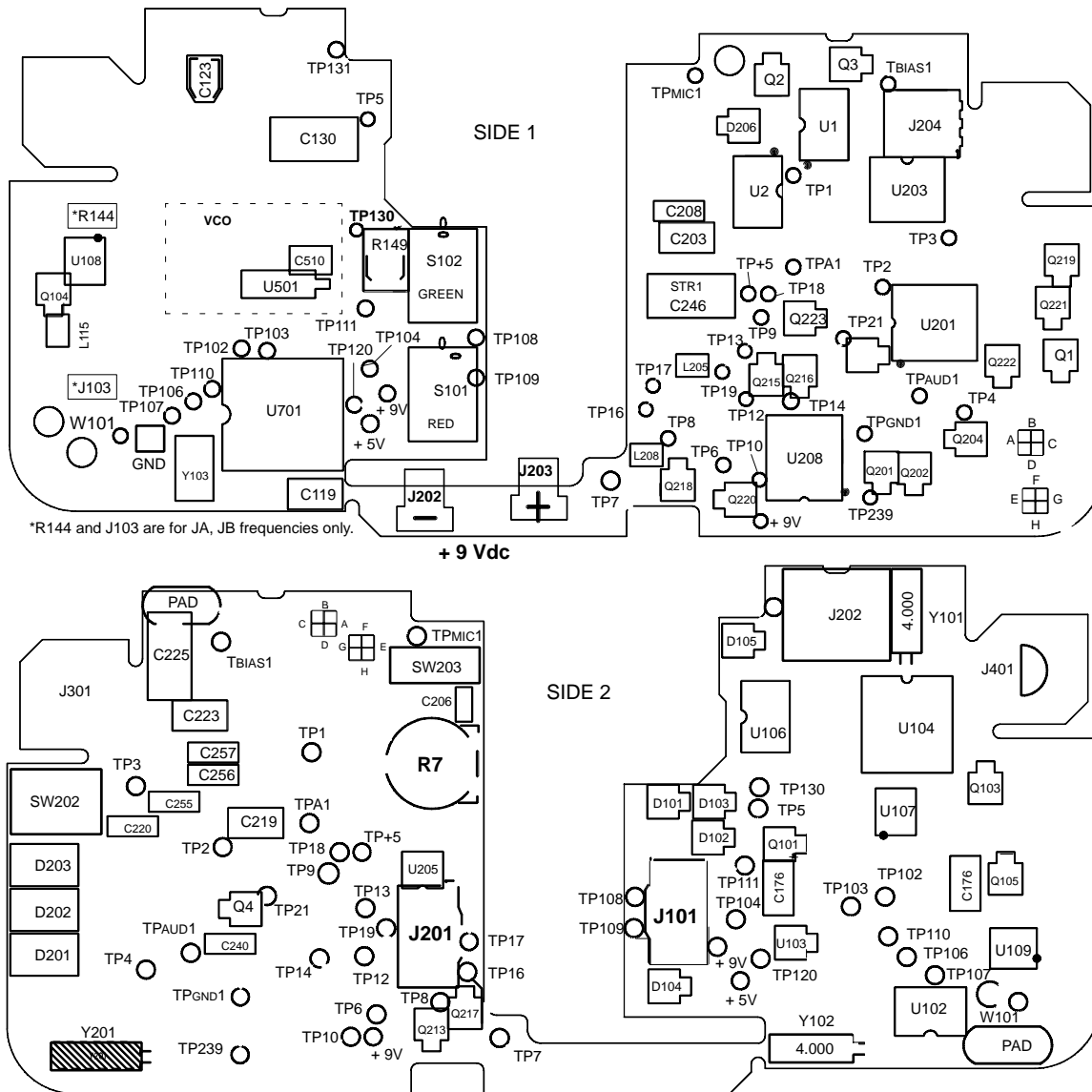

Figure 4. UC1 Major Test Component Locations

1. Use the PT1843 cable to connect the rf-digital board and the audio board through the 11-pin board interconnects (J101, J201, side 2).
2. Apply +9 Vdc across the battery terminals (J202, J203, side 1).
3. Set audio GAIN potentiometer (R7, side 2) to minimum (full counter-clockwise).
4. Rf power and tone key level measurements are made by connecting W101 (rf output) to the spectrum analyzer. Use the frequency counter to measure frequency. For JA, JB frequencies, connect J103 (rf output) to the spectrum analyzer and frequency counter.
5. See Table 2 for frequency settings.

Alignment

Alignment Set-Up

Table 2 lists the group carrier frequencies and tuning voltages for all the service tests that follow.

*Table 2
Group Carrier Frequencies and Tuning Voltages
(in order by carrier frequency)*

Group	Group Code	Group Switch (S101)	Channel Switch (S102)	Carrier Frequency (MHz)	VCO Tuning Voltage (TP130)	Deviation (kHz)
UA	A	4	0	805.500	3.7	45
MB	B	1	3	805.500	1.8	15
JA	C	0	2	805.500	3.5	5
JB	D	4	2	807.500	3.7	5
KK	E	5	5	851.125	3.5	15
MC	–	–	–	–	–	–

Frequency

Use this service procedure to correctly align the transmitter's operating (output) frequency. C510 tunes the voltage-controlled oscillator (VCO) to the operating frequency selected, with a 1 – 4 Vdc tuning range.

C123 adjusts the reference oscillator on the synthesizer.

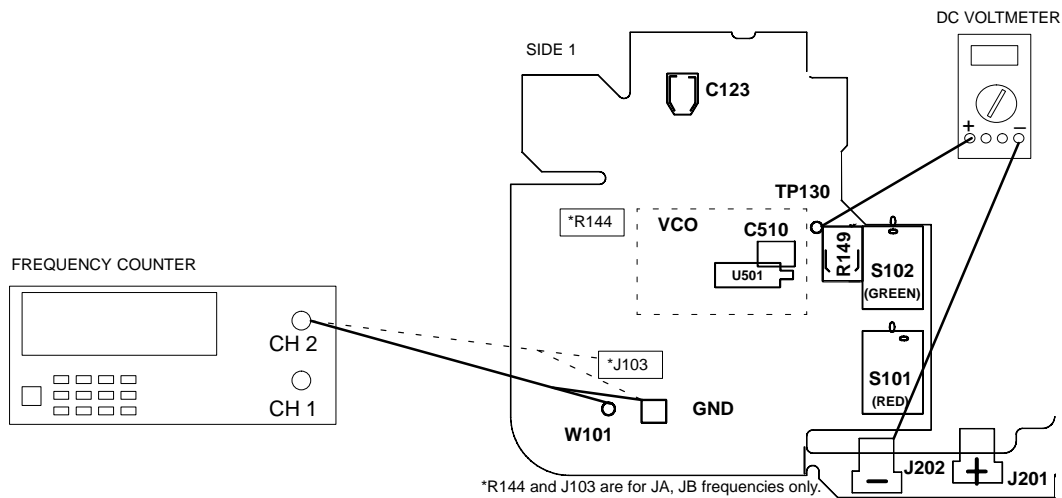

UC1 Transmitter		Frequency Counter		DC Voltmeter	
Power:	ON	Operating freq:	See Table 2	Connect + :	TP130
Operating freq:	See Table 2	Connect CH 2:	W101 and GND For JA, JB use J103 and GND	Connect - :	J202 (ground)

Figure 5. UC1 Frequency Alignment Test Set-Up

1. Remove the antenna and connect the 50 Ω cable, center conductor to W101, and shield to GND, as shown in Figure 5. (For JA, JB frequencies, use J103 and GND.)
2. Connect the BNC cable end to the frequency counter, CH 2.
3. Measure the dc voltage at TP130 (tuning voltage line) and ground (GND).
4. Use the pink tory to adjust the VCO trimmer, C510, until the voltmeter reading equals that shown in Table 2, ± 0.125V..
5. Use the blue tory to adjust the variable capacitor, C123, until the frequency counter measurement matches the desired frequency, within ± 1 kHz.
6. Disconnect the test cable from the frequency counter.
7. Use the test set-up and equipment settings in Figure 6 for the next test, the power output measurement.

Power Output Measurement

The output power measurement ensures that the output signal is strong enough for sufficient range when the system is in use. The output power measurement also verifies that the output power is not above the specified maximum level, to ensure compliance with regulatory agencies' standards.

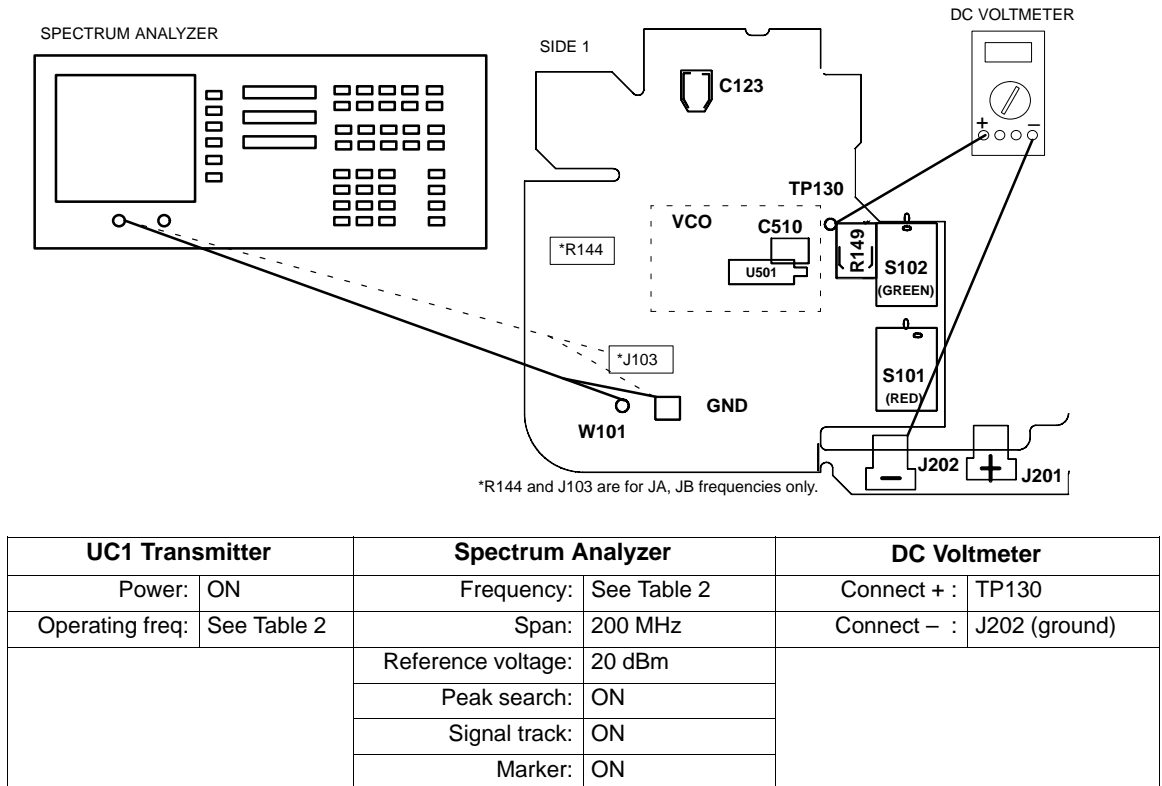

Figure 6. UC1 Power Output Measurement Test Set-Up

1. Remove the BNC cable end from the frequency counter and connect it to the 50 Ω input of the spectrum analyzer. Use the equipment settings shown in Figure 6.
2. Measure the output power. The output power should be:
 - UA, MB, MC frequencies: 16 + 1 / - 2 dBm
 - KK frequencies: 14 + 1 / - 2 dBm
 - JA, JB frequencies: Adjust R144 to obtain 8.8 ± 0.5 dBm.
3. Turn the UC1 power OFF.
4. Remove the BNC end of the cable from the spectrum analyzer, but leave the bare end soldered to the printed circuit board (pcb). (For JA, JB frequencies, leave the adapter cable connected to J103.)

Deviation Reference Voltage: Using a UC4 or U4S Receiver

Deviation must be set to make sure the companding systems between the transmitter and receiver correctly track each other. The level coming out of the transmitter’s audio compressor must match the level going into the receiver’s audio expander. A fixed gain structure does not ensure an exact match, primarily because of variations in voltage-controlled oscillators (VCOs).

This test requires a UC4 or U4S receiver and is designed to tune the transmitter regardless of the accuracy of the receiver’s tuning. However, it is recommended that a properly-tuned receiver be used to perform the transmitter deviation adjustment.

Be sure to use a KK model receiver when tuning a KK model transmitter.

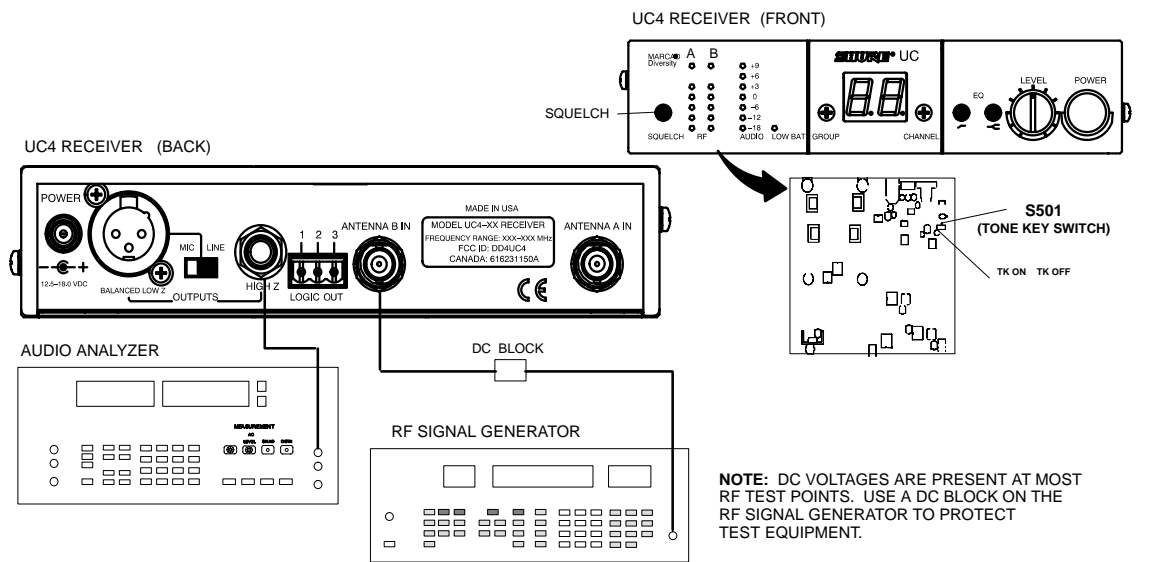

UC4 Receiver		Audio Analyzer		Rf Signal Generator	
Output:	Unbalanced	Measurement:	AC level	INT:	FM
Gain:	Maximum	Filters:		INT:	1 kHz
Squelch:	Mid	Low-Pass (30 kHz):	ON	Output Amplitude:	-60 dBm
Tone Key (S501):	OFF	High-Pass (400 Hz):	ON	Frequency:	See Table 2
Operating freq:	See Table 2			Modulation:	See Table 2

Figure 7. Deviation Reference Voltage Test Set-Up, Using a UC4 or U4S Receiver

1. See Figure 7 for equipment test set-up and equipment settings.
2. Connect the rf signal generator output to the UC4 receiver antenna input (A or B).
3. Turn the UC4 receiver on and set switch S501 inside the UC4 receiver to the OFF position to disable the tone key function.
4. Connect the audio voltmeter to the receiver’s unbalanced output.
5. Measure the output voltage.

Record this voltage. This is the *deviation reference voltage*.

Deviation Adjustment Voltage: Using a UC4 or U4S Receiver

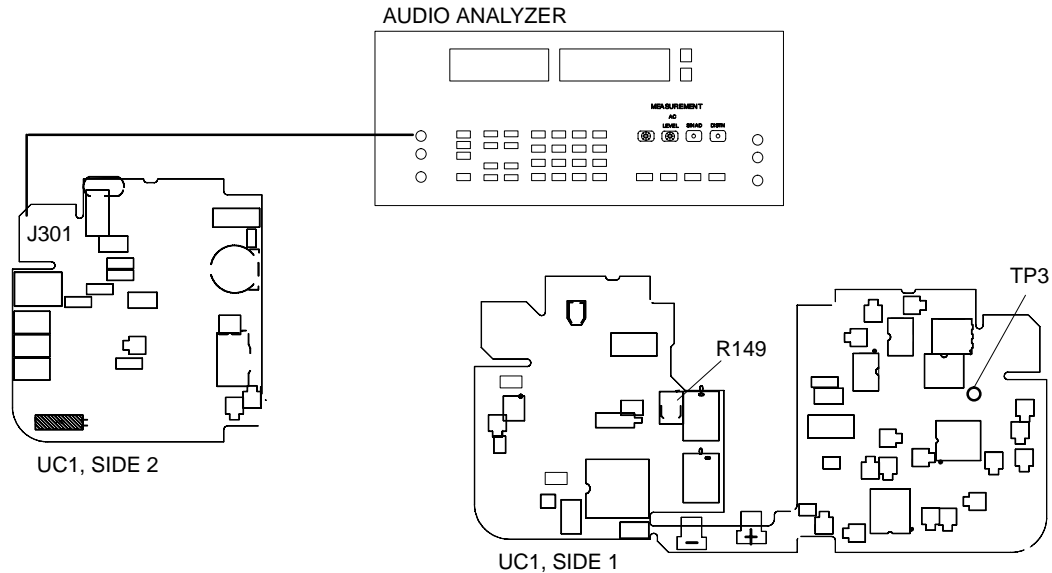

UC1 Transmitter		Audio Analyzer	
Power:	+9 Vdc	Measurement:	AC level
Gain:	Minimum	Output:	1 kHz
		Filters:	
		Low-Pass (30 kHz):	ON
		High-Pass (400 Hz):	ON

Figure 8. Deviation Adjustment Voltage Test Set-Up, Steps 1 through 4, Using a UC4 or U4S Receiver

1. Disconnect the rf signal generator from the UC4 receiver. Make sure the tone key switch (S501) is in the ON position.
2. Use the BNC to TINI QG cable to connect the audio analyzer output to the MIC input of the transmitter (J301).
3. Set the audio analyzer to 1 kHz.
4. Turn the UC1 power back ON.
5. Adjust the UC1 audio input level using the audio analyzer output to get the following readings at TP3, ± 0.02 dB:

Model:			
UA	MB, MC	JA, JB	KK
-6.8 dBu	- 16.3 dBu	- 23.47 dBu	- 15.3 dBu

6. See Figure 9 for equipment set-up and equipment settings for steps 7 through 8.

Deviation Adjustment Voltage: Using a UC4 or U4S Receiver

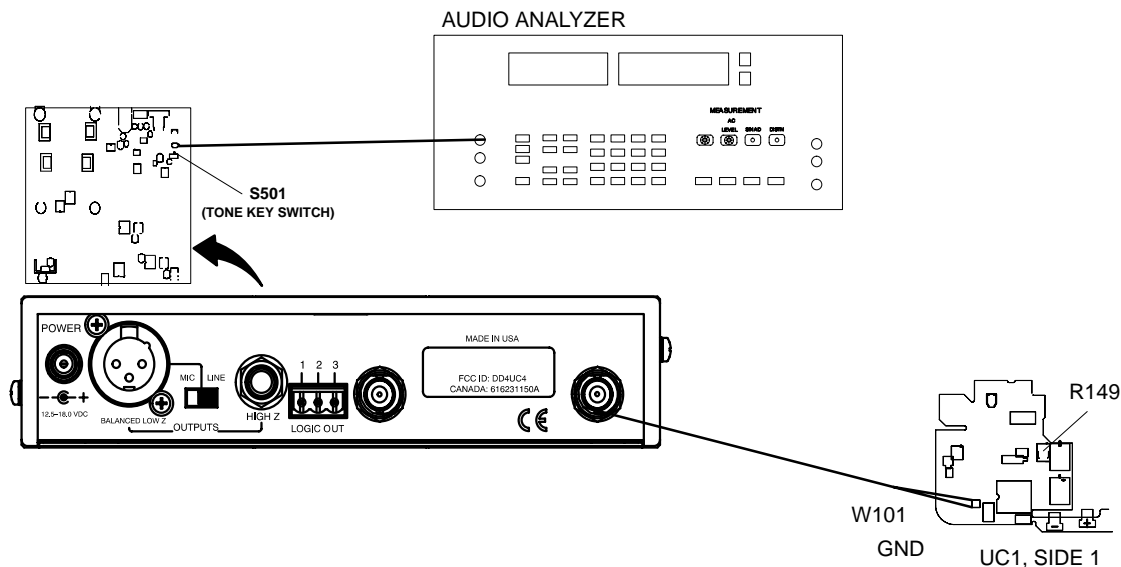

UC4 Receiver		UC1 Transmitter		Audio Analyzer	
Output:	Unbalanced	Power:	+ 9 Vdc	Measurement:	AC level
Gain:	Maximum	Gain:	Minimum	Output:	1 kHz
Squelch:	Mid			Filters:	
Tone key (S501):	ON			Low-Pass (30 kHz):	ON
				High-Pass (400 Hz):	ON

Figure 9. Deviation Adjustment Voltage Test Set-Up, Steps 7 through 8, Using a UC4 or U4S Receiver

7. Connect the BNC end of the test cable that is soldered to W101 and GND to the antenna A or B inputs.
8. Turn ON the UC1 and adjust R149 until the audio volt-meter connected to the unbalanced output of the UC4 reads the same as the *deviation reference voltage*, measured above, ± 0.1 dB.

R149 adjusts the deviation for 45 kHz, 100% modulation.

Deviation Reference Voltage: Using a Modified SC4 IF Receiver

Deviation tests can also be performed using a modified SC4 IF receiver. For instructions on modifying an SC4 receiver, consult the *Shure Service Equipment* manual.

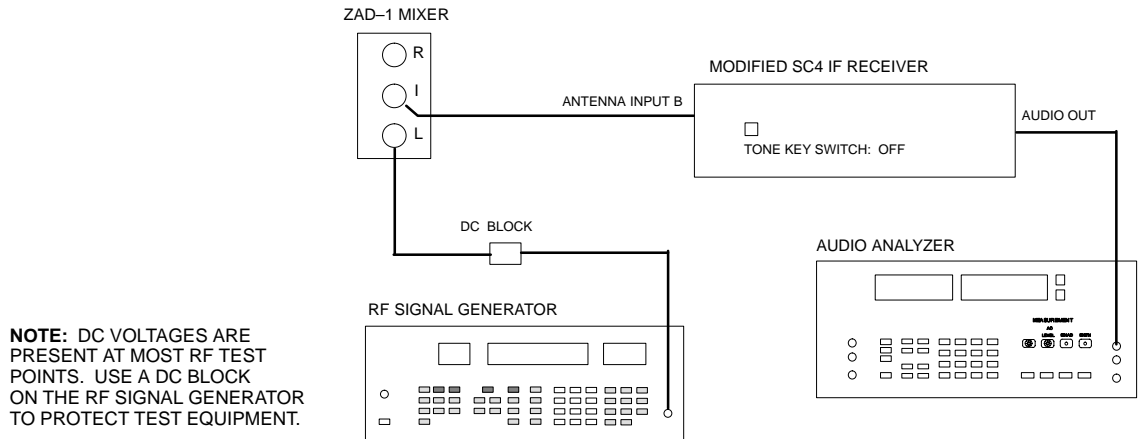

SC4 IF Receiver		Audio Analyzer		Rf Signal Generator	
Output:	Unbalanced	Measurement:	AC level	INT:	FM
Gain:	Maximum	Filters:		INT:	1 kHz
Squelch:	Mid	Low-Pass (30 kHz):	ON	Output Amplitude:	+ 7 dBm
Tone Key switch:	OFF	High-Pass (400 Hz):	ON	Frequency:	10.7 MHz
Operating freq:	See Table 2			Modulation:	See Table 2

Figure 10. Deviation Reference Voltage Test Set-Up, Using a Modified SC4 IF Receiver

1. See Figure 10 for equipment test set-up and equipment settings.
2. Connect the rf signal generator output to the input port L (local oscillator) of a Zad-1 mixer
3. Connect the output port I (intermediate frequency) of the Zad-1 mixer to antenna input B of the SCR IF receiver.
4. Turn the SC4 IF receiver ON and set the tone key switch on the front panel of the SCR IF receiver to OFF.
5. Connect the audio voltmeter to the receiver's unbalanced output.
6. Measure the output voltage.

Record this voltage. This is the *deviation reference voltage*.

Use the same Zad-1 mixer connections for the next adjustment test.

Deviation Adjustment Voltage: Using an SC4 IF Receiver

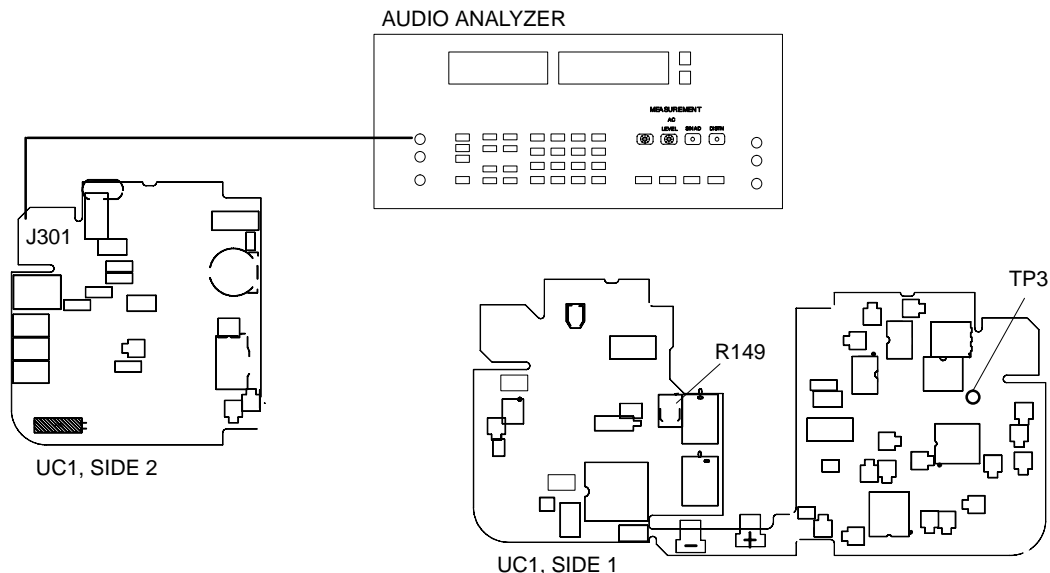

UC1 Transmitter		Audio Analyzer	
Power:	+9 Vdc	Measurement:	AC level
Gain:	Minimum	Output:	1 kHz
		Filters:	
		Low-Pass (30 kHz):	ON
		High-Pass (400 Hz):	ON

Figure 11. Deviation Adjustment Voltage Test Set-Up, Steps 1 through 5, Using a Modified SC4 IF Receiver

1. Disconnect the rf signal generator from the SC4 receiver.
2. Set the SC4 tone key switch on the SC4 front panel to ON.
3. Use the BNC to TINI QG cable to connect the audio analyzer output to the MIC input of the transmitter (J301).
4. Set the audio analyzer frequency to 1 kHz.
5. Turn the UC1 power back ON.
6. Adjust the UC1 audio input level using the audio analyzer output to get the following readings at TP3, ± 0.02 dB:

Model:			
UA	MB	JA, JB	KK
-6.8 dBu	- 16.3 dBu	- 23.47 dBu	- 15.3 dBu

See Figure 12 for equipment set-up and settings for steps 7 through 9.

Deviation Adjustment Voltage: Using a Modified SC4 IF Receiver

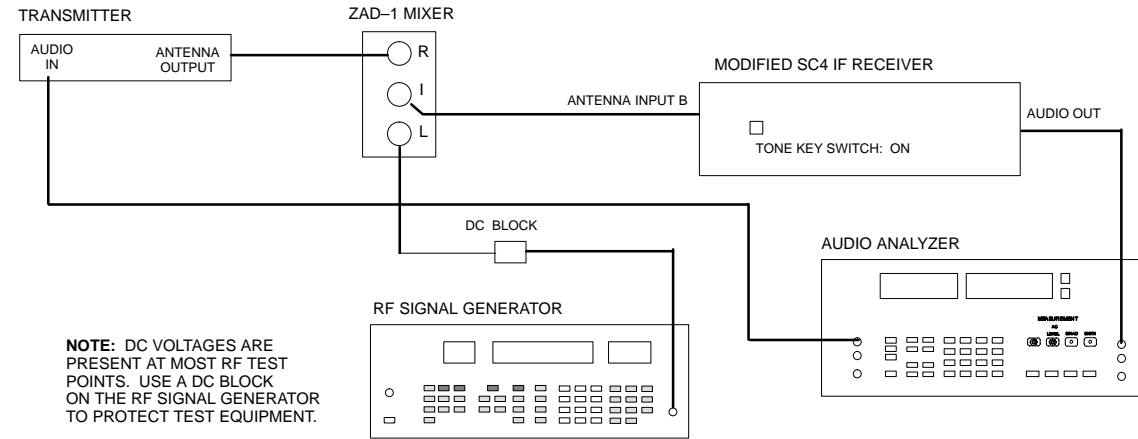

SC4 IF Receiver		UC1 Transmitter		Audio Analyzer		Rf Signal Generator	
Output:	Unbalanced	Power:	+ 9 Vdc	Measurement:	AC level	INT:	FM
Gain:	Maximum	Gain:	Minimum	Output:	1 kHz	INT:	1 kHz
Squelch:	Mid			Filters:		Output amplitude:	+ 7 dBm
Tone Key switch:	ON			Low-Pass 30 kHz:	ON	Modulation:	See Table 2
				High-Pass 400 Hz:	ON	Frequency:	Oper. Freq. minus 10.7 MHz

Figure 12. Deviation Adjustment Voltage Test Set-Up, Steps 7 through 9, Using a Modified SC4 IF Receiver

7. Connect the UC1 rf output test cable BNC end to the input port R (rf output) of the Zad-1 mixer.
8. Change the rf signal generator frequency to the frequency given in Table 2, minus 10.7 MHz.
9. Turn ON the UC1 and adjust R149 until the audio volt-meter connected to the unbalanced output of the UC4 reads the same as the *deviation reference voltage*, measured above, ± 0.1 dB.

Operating Specifications

After tuning, the unit should meet the following specifications.

*Table 3
Operating Specifications*

Specification	Minimum	Typical	Maximum
Current drain	50 mA	60 mA	70 mA
Frequency	-1.0 kHz	See Table 2	+1.0 kHz
Audio freq response @ 100 Hz wrt 1 k	-5.0 dB	-4.0 dB	-3.0 dB
Audio freq response @ 10 Hz wrt 1 k	+8.0 dB	+9.0 dB	+10.0 dB
UA:			
System S/N @ 45 kHz, A weighted	95.0 dB	100.0 dB	-
Output power, UA, without C347	14.0 dBm	16.0 dBm	17.0 dBm
MB, MC			
System S/N @ 1% THD, A weighted	80.0 dB	85.0 dB	-
Output power, without C347	14.0 dBm	16.0 dBm	17.0 dBm
KK:			
System S/N @ 1% THD, A weighted	80.0 dB	85.0 dB	-
Output power, without C347	12.0 dBm	14.0 dBm	15.0 dBm
JA, JB:			
System S/N @ 1% THD, A weighted	85.0 dB	90.0 dB	-
Output power, at J2, with C347 in place	8.3 dBm	8.8 dBm	9.3 dBm

Bench Checks

Dc Problems

Make all dc measurements with respect to the rf ground, unless otherwise specified.

- ✓ Verify that the battery voltage is between 6.0 Vdc and 9.5 Vdc.
- ✓ Check for +5 Vdc at labeled test points on the audio and rf boards.
- ✓ If incorrect voltage is present, check the biasing resistors' values.
- ✓ Trace the dc back to the battery and check the power switch.
- ✓ Look for open coils, cracked parts, reversed polarity capacitors, and solder shorts.
- ✓ If there is a short to ground from 5 Vdc, try to isolate different parts of the circuit.
- ✓ Verify that the rf OFF signal changes from +5 Vdc at power up and power down to 0 Vdc during normal operation. Trace the signal to the microprocessor. Q101 should be saturated during normal operation.
- ✓ Verify that the battery voltage appears at U205, pin 6, (TP +9 Vdc).

Rf Frequency Problems

- ✓ If the carrier is out of specification by less than 40 kHz and cannot be corrected by adjusting C123, check the values of C123, C124, and Y101. If these values are correct, replace Y101. As a last resort, replace the synthesizer, U104.
- ✓ If the carrier frequency is not 782 and 810 MHz, or is unstable, the loop is unlocked:

Check solder connections at the VCO, microprocessor (traces LE, D, and CK) and synthesizer, U104.

Check for 4 MHz oscillation at U104, pins 1 and 2. If there is not 4 MHz oscillation, replace the crystal, Y104.

Check the values and polarity of the loop filter: R121, R122, R123, C129, C130, C131, and C132. Check the bias voltage of U104, pins 3 and 4; and U106, pin 8. As a last resort, replace the synthesizer, U104.

The tuning voltage of the VCO at U104, pin 5, should be approximately 3 Vdc when the transmitter is programmed for 800 MHz operation.

Low Rf Output Power

- ✓ Check the polarity of the low-pass filters U107, U108, and U109. (Pin 1 is marked with a dash.)
- ✓ Check for missing ground connections.
- ✓ Verify the VCO output power at R128 and U104, pin 8.
- ✓ Check the dc level at the VCO Vcc pin.
- ✓ Isolate the VCO from the rest of the circuit by removing R127, R128, and C134. The carrier frequency will no longer be locked, but the output power from the VCO should be approximately 0 dBm.
- ✓ If the power out of the VCO is still low, the VCO is bad. Replace the rf board.
- ✓ Verify the dc bias of Q102 and Q104. Verify the rf mute signal changes from +5 Vdc at power up and power down, to 0 Vdc during normal operation. If Q103 and Q105 are not saturated during normal operation, the rf power at the antenna port will be attenuated by about 45 dB.
- ✓ Isolate components starting from the antenna port and working back to the rf power amp.
- ✓ Remove the low-pass filter and check the power OUT of the amplifier.
- ✓ Check the values of the output matching network for Q102 and Q104, C258, L206, and C256. Look for open coils.
- ✓ Check the values of the bypass capacitors.
- ✓ As a last resort, replace the transistors, Q102 and Q104.

Excessive Current Drain

- ✓ Isolate different sections of the circuit; rf, audio, and digital. Look for reversed polarity capacitors or wrong resistor values.

Deviation Problems

- ✓ If R149 cannot be adjusted to obtain the desired deviation, try to isolate the problem to the audio or rf section.
- ✓ Check the value of R149. To check the rf section, set the transmitter frequency to 800 MHz and verify that the tuning voltage of the VCO (U104, pin 5) is approximately 3 Vdc.

Audio Problems

No Tone Key

No tone key means that the 32 kHz tone key sidebands are not visible when the carrier is viewed on a spectrum analyzer. If tone key levels are there but are too low, the deviation is off and needs to be recalibrated.

- ✔ Apply a 1 kHz tone at a level of 0 dBu to the audio input with the audio gain pot at minimum.
- ✔ If the carrier on the spectrum analyzer does not show any deviation, check part integrity and audio path continuity between U201, pin 1, and the VCO.
- ✔ If the spectrum analyzer shows a deviated carrier, probe for a 32 kHz signal at TP4 and I246 and continue to the next step.
- ✔ If there is a signal at I246 but not at TP4, then the mute circuit through Q4 or Q211 is being activated. Verify that the logic signal at Q4 and Q211, pin 1, is logic low. If it is low, replace Q4 or Q211. If it is not low, check the line for a short to +5 V. If there is no short, the microprocessor is defective and must be replaced.
- ✔ If there is a 32 kHz signal at both I246 and TP4, replace R248.
- ✔ If there is not a 32 kHz signal at either I246 or TP4, there is something wrong with the tone key circuit or the tone key supply voltage. If the tone key supply voltage (U201, pin 7) is less than 2 V, there is a problem with one or more of the following components: R284, R287, R285, R286, C289, Q222, C222, R228, or R229..
- ✔ If the voltage at U201, pin 7, is greater than 2 V, the problem is in the tone key circuit itself. Check for shorts and opens. Replace parts in this circuit beginning with the crystal until the 32 kHz oscillation returns.

No Audio

- ✔ View the carrier on the spectrum analyzer. If there are not 32 kHz tone key sidebands around the carrier, follow the steps above for “No Tone Key.”
- ✔ If there are tone key sidebands around the carrier, verify that the signal generator is properly outputting signal.
- ✔ Verify +9 V, half-supply bias, and ground connections to U2.
- ✔ Verify +9 V, half-supply bias, and ground connections to U201.
- ✔ Follow the audio path from where audio is applied until the point of discontinuity is reached and replace the appropriate part.

Notes

This page intentionally left blank.

Replacement Parts and Drawings

Product Changes

Six versions of the UC1 and UC1L transmitters are available for use in various countries. Each version is identified below by country code, country designation, frequency range, and printed circuit board number.

Parts Designations

The following comments apply to the parts list and the schematic:

Resistors: Unless otherwise noted, all resistors are surface-mount with $\frac{1}{10}$ W rating and 1% tolerance.

Capacitors: Unless otherwise noted, non-polarized capacitors are surface-mount NPO dielectric types with a 100 V capacity and a 5% tolerance, and polarized capacitors are tantalum types.

Table 4
UC1 / UC1L Model Frequency Variations
(in order by frequency)

Country Code	Country Designation	Frequency Range	UC1 Printed Circuit Board #	UC1L Printed Circuit Board #
MC	Netherlands	774 – 782 MHz	90MC8790H	90MC8791H
UA	U.S.A. and Canada	782 – 806 MHz	90UA8790H	90UA8791H
JA	Japan	797 – 806 MHz	90JA8790H	90JA8791H
MB	Europe	800 – 830 MHz	90MB8790H	90MB8791H
JB	Japan	806 – 810 MHz	90JB8790H	90JB8791H
KK	United Kingdom	838 – 862 MHz	90KK8790H	90KK8791H

Table 5
Replacement Parts

Reference Designation	Description	Shure Part Number
MP1	Antenna	70A8015
MP2	Belt clip	44A8013A
MP3	Bushing	66A308
MP4	Case back	65A8295A
MP5	Case front	65A8294A
MP6	Compression pad	36A8078
MP7	Door	65A8296
MP8	Foam pad	36A8073

Shure UC1 Body-Pack UHF Transmitter

Table 6
Printed Circuit Board Components

Reference Designation	Description	Shure Part Number
C123	Capacitor, trimmer, 5 – 40 pF	152F03
C510	Capacitor, trimmer, 1.4 – 3.0 pF	152A04
D101–104	Diode, dual switching, SOT-23	184A07
D105, 206	Diode, signal / switching, SOT-23	184A08
D201	LED, right angle, green	184F32
D202	LED, right angle, yellow	184E32
D203	LED, right angle, SMT, red	184D32
D501	Diode, rf tuning	184A36
J102	Jack, stereo, 35 mm	95A8774
J201	Connector, receptacle	170A08
J202,203	Battery contacts	56A8072A
J204	Connector, strip socket	170C15
J301	Receptacle, male, 4-pin, TINI QG	95A8413
J401	Connector, LEMO (UC1L)	95A8601
P301,305	Connector, interconnect strip	56D8074
Q1,4,211,215, 216,218	Transistor, SOT-23, FET, TMOS	183A30
Q101,213	Transistor, SOT-23, PNP	183A01
Q102,501,502	Transistor	183A48
Q103,105,217	Transistor, power, MOSFET	183A46
Q104	Transistor, SOT-23	183A49
Q201,202,204, 219,220,221, 222, 223	Transistor, SOT-23, NPN	183A02
R7	Potentiometer, gain	46H8014
R149	Potentiometer, trim	146B02
SW202	Switch, toggle, DPST	55A189
SW203	Switch, slide	55A8087
Y101	Crystal, 4 MHz	40A8012
Y201	Crystal, 32.768 kHz	40A8010
U2	IC, dual op amp	188A18
U101	IC, microprocessor, programmed	188D238E
U102	IC, EEPROM	188A131
U103	IC, detector	188C210
U104	IC, PLL frequency synthesizer	188A265
U201	IC, quad op amp	188A49
U203	IC, compander	188A126
U205	IC, voltage regulator, 5 V	188A115
U208	IC, quad comparator	188A123
U501	Resonator, dielectric	140A14

Table 7
Group Designators
(in order by frequency)

Frequency Range (MHz)	Country Designation	Country Code	R27 kΩ	R28 kΩ	R29 kΩ	R30 kΩ	R31 kΩ
774–782	Netherlands	MC	–	–	–	–	1.0
782–806	US & Canada	UA	–	–	–	–	–
797–806	Japan	JA,JB	–	1.0	–	–	–
800–830	Europe	MB	1.0	–	–	–	–
806–810	Japan	JB	–	–	1.0	–	–
838–862	England	KK	–	–	–	1.0	–

Country Code	R34 kΩ	R35 kΩ	R36 kΩ	R37 kΩ	R38 kΩ	R39 kΩ	R41 kΩ
MC	–	–	–	–	–	1.0	–
UA	1.0	–	–	–	–	–	–
JA,JB	–	–	1.0	–	–	–	–
MB	–	1.0	–	–	–	–	–
JB	–	–	–	1.0	–	–	–
KK	–	–	–	–	1.0	–	–

Table 8
Frequency Dependent Components
(in order by frequency)

Frequency Range (MHz)	Country Designation	Country Code	C7 pF	C8 uF	C12 pF	C117 pF	C118 pF	C173 pF	C215 uF
774–782	Netherlands	MC	0.047	0.1	100	–	–	27	2.2
782–806	US & Canada	UA	–	–	–			27	–
797–806	Japan	JA	0.047	0.1	100	27	27	–	2.2
800–830	Europe	MB	0.047	0.1	100	–	–	27	2.2
806–810	Japan	JB	–	–	–	27	27	–	–
838–862	England	KK	0.047	0.1	100	–	–	27	2.2

Country Code	C216 uF	C505 pF	C506 pF	C509 pF	J103	Q2	Q3	R1 kΩ	R2 kΩ	R3 kΩ
MC	–	3.3	3.3	1.8	–	183A01	183A02	10	1.5	249
UA	0.047	4.7	4.7	1.8	–	–	–	–	0	4.99
JA	–	4.7	4.7	1.8	170A14	183A01	183A02	10	10	249
MB	–	4.7	4.7	1.8	–	183A01	183A02	10	1.5	249
JB	0.047	4.7	4.7	1.8	170A14	–	–	–	0	4.99
KK	–	–	–	–	–	183A01	183A02	10	1.5	249

Country Code	R9 kΩ	R11 kΩ	R12 kΩ	R13 kΩ	R14 kΩ	R15 kΩ	R16 MΩ	R17 MΩ	R18 kΩ	R25 kΩ	R26 kΩ
MC	–	100	100	40.2	100	10	1.0	1.0	22.1	–	–
UA	0	–	–	–	–	–	–	–	–	0	1.0
JA	–	100	100	40.2	100	10	1.0	1.0	22.1	–	–
MB	–	100	100	40.2	100	10	1.0	1.0	22.1	–	–
JB	0	–	–	–	–	–	–	–	–	0	–
KK	–	100	100	40.2	100	10	1.0	1.0	22.1	–	–

Country Code	R27 kΩ	R28 kΩ	R29 kΩ	R30 kΩ	R34 kΩ	R35 kΩ	R36 kΩ	R37 kΩ	R38 kΩ	R133 kΩ
MC	1.0	–	–	–	–	–	–	–	–	22.1
UA	–	–	–	–	1.0	–	–	–	–	22.1
JA	–	1.0	–	–	–	–	1.0	–	–	150
MB	1.0	–	–	–	–	1.0	–	–	–	22.1
JB	–	–	1.0	–	–	–	–	1.0	–	150
KK	–	–	–	1.0	–	–	–	–	1.0	22.1

Country Code	R144 1 kΩ	R286 kΩ	R287 kΩ	R298 kΩ	S101 GRP	S102 CH	U1	Y102	Y103
MC	–	200	24.9	–	155B11	155A11	183A136	–	140C15
UA	–	200	24.9	4.02	155B11	155A11	–	–	140C15
JA	146B02	24.9	–	–	155A11	155B11	183A136	40A8012	–
MB	–	200	24.9	–	155B11	155A11	183A136	–	140C15
JB	146B02	24.9	–	4.02	155B11	155A11	–	40A8012	–
KK	–	200	24.9	–	155B11	155A11	183A136	–	140C15

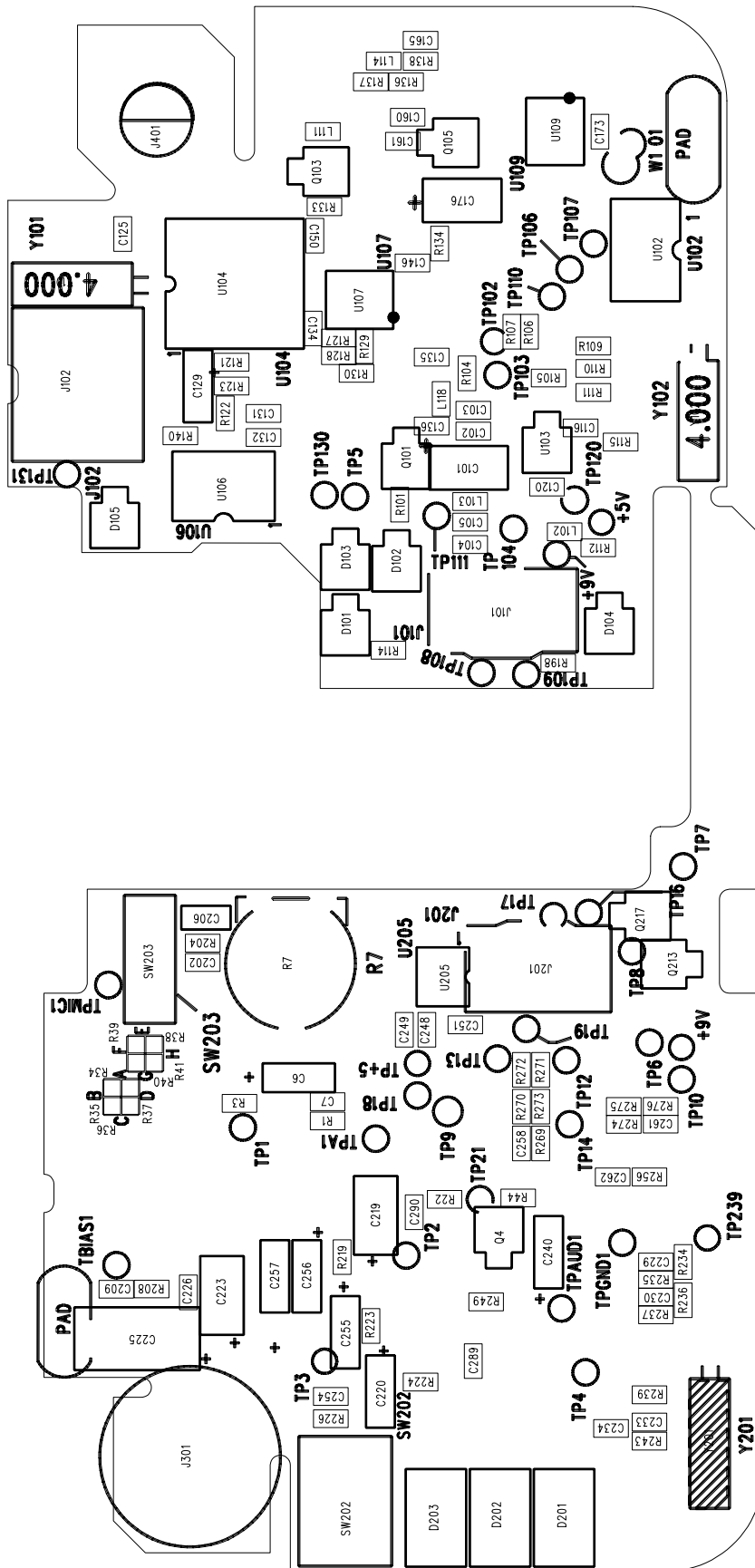

UC1 Body-Pack Transmitter
Audio-Rf Printed Circuit Board
Side 2