

STR1

Safety switch



Described product

STR1

Manufacturer

SICK AG
Erwin-Sick-Str. 1
79183 Waldkirch
Germany

Legal information

This work is protected by copyright. Any rights derived from the copyright shall be reserved for SICK AG. Reproduction of this document or parts of this document is only permissible within the limits of the legal determination of Copyright Law. Any modification, abridgment or translation of this document is prohibited without the express written permission of SICK AG.

The trademarks stated in this document are the property of their respective owner.

© SICK AG. All rights reserved.

Original document

This document is an original document of SICK AG.



Contents

1	About this document.....	5
1.1	Function of this document.....	5
1.2	Scope.....	5
1.3	Target groups and structure of these operating instructions.....	5
1.4	Additional information.....	5
1.5	Symbols and document conventions.....	6
2	Safety information.....	8
2.1	General safety notes.....	8
2.2	Intended use.....	8
2.3	Requirements for the qualification of personnel.....	8
3	Product description.....	10
3.1	Setup and function.....	10
3.2	Product characteristics.....	10
4	Project planning.....	12
4.1	Manufacturer of the machine.....	12
4.2	Operating entity of the machine.....	12
4.3	Design.....	13
4.4	Integration into the electrical control.....	13
4.5	Thorough check concept.....	17
5	Mounting.....	18
5.1	Safety.....	18
5.2	Unpacking.....	18
5.3	Possible mounting types.....	18
5.4	Mounting.....	20
6	Electrical installation.....	22
6.1	Safety.....	22
6.2	Notes on cULus.....	23
6.3	Device connection (flying leads).....	24
6.4	Device connection (M12, 5-pin).....	24
6.5	Device connection (M12, 8-pin).....	24
6.6	Connecting a cascade.....	25
7	Commissioning.....	28
7.1	Safety.....	28
7.2	Switching on.....	28
7.3	Teach-in.....	28
7.4	Thorough check.....	29
8	Troubleshooting.....	30
8.1	Safety.....	30

8.2	Diagnostic LEDs.....	30
9	Maintenance.....	33
9.1	Cleaning.....	33
9.2	Regular thorough check.....	33
10	Decommissioning.....	34
10.1	Protection of the environment.....	34
10.2	Disposal.....	34
11	Technical data.....	35
11.1	Technical data.....	35
11.2	Dimensional drawings.....	38
11.3	Response time and enable time in cascade.....	39
12	Ordering information.....	40
12.1	Scope of delivery.....	40
12.2	STR1 ordering information.....	40
13	Spare parts.....	42
13.1	Actuator.....	42
13.2	Sensors.....	42
14	Accessories.....	43
14.1	Connectivity.....	43
15	Annex.....	45
15.1	Compliance with EU directives.....	45
15.2	FCC and IC radio approval.....	46
16	List of figures.....	47
17	List of tables.....	48

1 About this document

1.1 Function of this document

These operating instructions contain the information needed during the life cycle of the safety switch.

They must be made available to all people who work with the safety switch.

1.2 Scope

The operating instructions only apply to the STR1 safety switch with the following information on the product packaging: Operating Instructions 8018074.

These operating instructions are included with SICK part number 8018074 (all available languages of this document).

1.3 Target groups and structure of these operating instructions

These operating instructions are intended for the following target groups: project developers (planners, developers, designers), installers, electricians, safety experts (such as CE authorized representatives, compliance officers, people who test and approve the application), operators, and maintenance personnel.

The structure of these operating instructions is based on the life cycle phases of the safety switch: project planning, mounting, electrical installation, commissioning, operation, and maintenance.

In many applications, the target groups consist of the manufacturer and the operating entity of the machine in which the safety switch is integrated:

Area of responsibility	Target group	Special chapters of these operating instructions ¹⁾
Manufacturer	Project developers (planners, developers, designers)	Project planning, page 12 Technical data, page 35 Accessories, page 43
	Installers	Mounting, page 18
	Electricians	Electrical installation, page 22
	Safety experts	Project planning, page 12 Commissioning, page 28 Technical data, page 35
Operating entity	Operators	Troubleshooting, page 30
	Maintenance personnel	Maintenance, page 33 Troubleshooting, page 30 Ordering information, page 40

¹⁾ Chapters not listed here are intended for all target groups. All target groups must follow all of the safety and warning instructions in all chapters of the operating instructions!

In other applications, the operating organization is also the manufacturer of the equipment with the corresponding allocation of the target groups.

1.4 Additional information

www.sick.com

The following information is available on the Internet:

- versions in other languages
- data sheets and application examples
- CAD data of drawings and dimensional drawings
- certificates (e.g. EU declaration of conformity)
- Guide for Safe Machinery (Six steps to a safe machine)

1.5 Symbols and document conventions

The following symbols and conventions are used in this document:

Safety notes and other notes



DANGER

Indicates a situation presenting imminent danger, which will lead to death or serious injuries if not prevented.



WARNING

Indicates a situation presenting possible danger, which may lead to death or serious injuries if not prevented.



CAUTION

Indicates a situation presenting possible danger, which may lead to moderate or minor injuries if not prevented.



NOTICE

Indicates a situation presenting possible danger, which may lead to property damage if not prevented.



NOTE

Indicates useful tips and recommendations.

Instructions for action

- ▶ The arrow denotes instructions for action.
- 1. The sequence of instructions for action is numbered.
- 2. Follow the order in which the numbered instructions are given.
- ✓ The check mark denotes a result of an instruction for action.

LED symbols

These symbols indicate the status of an LED:

- The LED is off.
- ◐ The LED is flashing.
- The LED is illuminated continuously.

Terminology

Dangerous state

A dangerous state is a status of the machine or facility, where people may be injured. Protective devices prevent this risk if the machine is operated within its intended use.

The figures in this document always show the dangerous state of the machine as movement of a machine part. In practice, there are different dangerous states, such as:

- Machine movements
- Electrical parts
- Visible and invisible beam
- A combination of multiple hazards

2 Safety information

2.1 General safety notes

This chapter contains general safety information about the safety switch.

Further information about specific product use situations can be found in the relevant chapters.



DANGER

Hazard due to lack of effectiveness of the protective device

In the case of non-compliance, it is possible that the dangerous state of the machine may not be stopped or not stopped in a timely manner.

- ▶ Read this document carefully and ensure that you have fully understood the contents before you work with the device.
 - ▶ Pay particular attention to all safety notes in this document.
-

Incorrect installation or manipulation can lead to severe injuries.

2.2 Intended use

The safety switch is a transponder safety switch that is switched in a non-contact manner by means of actuators, and is suitable for the following applications:

- Movable physical guards

The safety switch must only be used within the limits of the prescribed and specified technical data and operating conditions at all times.

Incorrect use, improper modification, or manipulation of the safety switch will invalidate any warranty from SICK AG; in addition, any responsibility and liability of SICK AG for damage and secondary damage caused by this is excluded.

The safety switch is **not** suitable for certain ambient conditions, including:

- Radioactivity (with the exception of natural radioactivity)
- Vacuum or high pressure
- High UV exposure
- In the vicinity of low-frequency RFIDs
- In the vicinity of magnetic fields

The following can impair the function of the safety switch:

- Metal subsurfaces or metal in the immediate vicinity (see "Design", page 13)
- Flying metal chips

2.3 Requirements for the qualification of personnel

The safety switch must be configured, mounted, connected, commissioned, and serviced by qualified safety personnel only.

Project planning

For project planning, a person is considered competent when he/she has expertise and experience in the selection and use of protective devices on machines and is familiar with the relevant technical rules and national work safety regulations.

Mechanical mounting, electrical installation, and commissioning

For the task, a person is considered qualified when he/she has the expertise and experience in the relevant field and is sufficiently familiar with the application of the protective device on the machine to be able to assess whether it is in an operationally safe state.

Operation and maintenance

For operation and maintenance, a person is considered competent when he/she has the expertise and experience in the relevant field and is sufficiently familiar with the application of the protective device on the machine and has been instructed by the machine operator in its operation.

3 Product description

3.1 Setup and function

The safety switch consists of two components:

- **Sensor**
The sensor is mounted on the fixed part of the protective device.
- **Actuator (transponder)**
The actuator is mounted on the moving part of the protective device.

When the protective device is closed, the actuator is guided to the sensor. When the switch on distance is reached, the sensor detects the actuator code. If the sensor detects a taught-in code (valid actuator), it sets safety outputs OSSD 1 and OSSD 2 (semiconductor outputs) to High and application diagnostic output Aux to Low.

When the protective device is opened, the actuator is removed from the response range of the sensor. The sensor sets safety outputs OSSD 1 and OSSD 2 to Low and application diagnostic output Aux to High.

3.2 Product characteristics

3.2.1 Product variants

The safety switch is delivered in different variants. You will find an overview of important distinguishing features of the variants in the following.

- Universally coded, unique coded, and permanently coded safety switches
- Actuator design: "Standard", "Flat", or "Mini"
- Cable with M12 plug connector (5-pin or 8-pin) or flying leads (3 m or 10 m)

Complete overview of all variants: [see "STR1 ordering information", page 40.](#)

Coding

- **Universally coded**
All actuators are accepted. No teach-in is required.
- **Unique coded**
An actuator must be taught in during commissioning. Up to 8 actuators may be taught in one after the other. Only the most recently taught-in actuator is valid. Previously taught-in actuators can no longer be used.
- **Permanently coded**
An actuator must be taught in during commissioning. Teach-in only needs to be performed once. It is not possible to teach in any further actuators.

3.2.2 Active sensor surfaces

The sensor has 3 active sensor surfaces:

- Front: black surface
- 2 x sides: yellow surface with long black edge

3.2.3 Fault detection

Faults that arise, including internal device faults, are detected no later than the next requirement to close the safety contacts (e.g., when the machine starts). The safety switch then switches to the safe state. If a fault is detected, the safety circuit is switched off and the DIAG and STATE light emitting diodes display the fault ([see table 10](#)).

3.2.4 Cascading

In the case of cascading, up to 30 safety switches are connected in series.

For more information, see ["Cascading", page 16](#) and see ["Connecting a cascade", page 25](#)

3.2.5 State indicators

The STATE light emitting diode (red/green) and the DIAG light emitting diode (yellow) signal the operational state of the safety switch.

Complete overview of the light emitting diode states and their meanings: see ["Diagnostic LEDs", page 30](#).

3.2.6 Protective functions

The safety switch has the following internal protective functions:

- Short-circuit protection at all outputs
- Cross-circuit monitoring at OSSDs
- Overload protection at OSSDs
- Reverse polarity protection for the supply voltage

4 Project planning

4.1 Manufacturer of the machine

**DANGER**

Failure to comply with manufacturer's obligations

Hazard due to lack of effectiveness of the protective device

- ▶ Perform a risk assessment before using the safety switch.
 - ▶ Do not manipulate, open, or modify components of the safety switch.
 - ▶ Do not repair defective devices; replace them instead.
 - ▶ Make sure the switch-on commands that cause the machine to enter a dangerous state only take effect when the protective device is closed.
 - ▶ Make sure a stop command is triggered when the protective device is opened in a hazardous machine state.
 - ▶ Safety switches must not be bypassed (i.e., the contacts jumpered), swiveled out of the way, removed, or rendered ineffective in any other way. If necessary, take measures to reduce the possibility of bypassing.
-

If multiple devices are connected in series (cascaded) and the simplified procedure according to ISO 13849 is used to determine the performance level (PL), the PL may drop.

As the number of safety switches in a cascade increases, so too does the response time.

4.2 Operating entity of the machine

**DANGER**

Failure to comply with operating entity's obligations

Hazard due to lack of effectiveness of the protective device

- ▶ Modifications to the machine and modifications to the mechanical mounting of the safety switch necessitate a new risk assessment. The results of this risk assessment may require the operating entity of the machine to fulfill the manufacturer's obligations.
 - ▶ Apart from during the procedures described in this document, the components of the safety switch must not be opened or modified.
 - ▶ Do not perform repair work on the components. Improper repair of the safety switch can lead to a loss of the protective function.
 - ▶ Make sure that bypassing is not carried out by substitute actuators. Restrict access to actuators for unlocking.
-

4.3 Design



DANGER

Bypassing the protective device

Hazard due to lack of effectiveness of the protective device

- ▶ Prevent incentives to manipulate the safety switch by taking at least one of the following measures:
 - Universally coded variant only:
 - Cover the sensor and the actuator with additional equipment or protect them against access.
 - If possible, use non-detachable mounting methods for actuators (such as welding, gluing, safety screws, or rivets).

Mounting location

- ▶ When the protective device is closed, the sensor and actuator must face each other at the safe switch on distance of S_{ao} or closer (see table 3).
- ▶ Select a mounting location that allows the sensor and actuator to be accessed for maintenance work and protects them against damage.
- ▶ If possible, mount the sensor and actuator on non-ferrous subsurfaces and at a distance from metallic parts in order to avoid affecting the sensing range. If this is not possible, the effect on the safe switch on distance S_{ao} and the safe switch off distance S_{ar} must be checked.
- ▶ Make sure that there is no possibility of hazards arising when the protective device is opened, even if the actuator has not yet reached the safe switch off distance S_{ar} .
- ▶ If the actuator is approaching the sensor in a parallel position, observe the minimum distances (see table 3).
- ▶ If necessary, attach an additional stop for the moving protective device.

Distance

If multiple safety switches are mounted on the machine, they must be mounted with a minimum distance in relation to one another; see "Mounting", page 20.

Alignment

The sensor can be mounted in any alignment see "Mounting", page 20, see "Possible mounting types", page 18.

Actuating direction

The actuator may approach the front or the long side of the sensor.



NOTE

If the actuator does not move directly onto the sensor when the protective device is closed, but instead approaches it in a parallel position, the specified minimum distance must be adhered to. This prevents the sensor from enabling the safety outputs despite the protective device not being fully closed.

4.4 Integration into the electrical control

Switch-on commands that cause the machine to enter a dangerous state may only take effect when the protective device is closed. In cases where the machine is in a dangerous state, a stop command must be triggered if the protective device opens. Depending on the safety concept, the signal is analyzed by, e.g., safety relays or a safety controller.

4.4.1 OSSDs

Safety switches with local inputs and outputs can be directly integrated into the machine controller.



DANGER

Hazard due to lack of effectiveness of the protective device

In the case of non-compliance, it is possible that the dangerous state of the machine may not be stopped or not stopped in a timely manner.

► Make sure that the following control and electrical requirements are met so the protective function can be fulfilled.

- The output signals from an OSSD pair must not be connected to each other.
- In the machine controller, both signals from an OSSD pair must be processed separately.

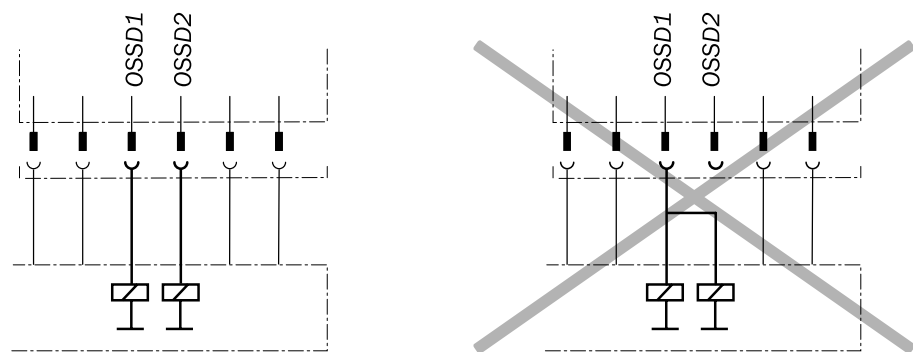

Figure 1: Dual-channel and isolated connection of OSSD 1 and OSSD 2

- The machine must switch to the safe state at any time if at least one OSSD in an OSSD pair switches to the OFF state.
- Prevent the formation of a potential difference between the load and the protective device. If you connect loads to the OSSDs (safety outputs) that then also switch if controlled with negative voltage (e.g., electro-mechanical contactor without reverse polarity protection diode), you must connect the 0 V connections of these loads and those of the corresponding protective device individually and directly to the same 0 V terminal strip. In the event of a fault, this is the only way to ensure that there can be no potential difference between the 0 V connections of the loads and those of the corresponding protective device.

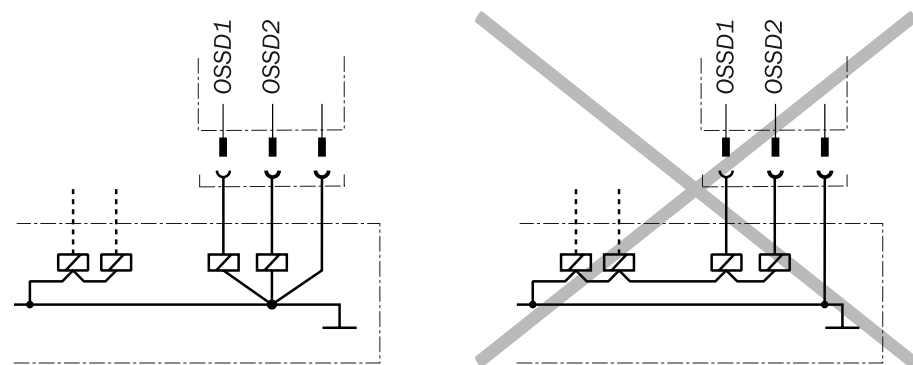

Figure 2: No potential difference between load and protective device

**DANGER**

Hazard due to lack of effectiveness of the protective device

In the case of non-compliance, it is possible that the dangerous state of the machine may not be stopped or not stopped in a timely manner.

Downstream contactors must be positively guided and monitored depending on applicable national regulations or required reliability of the safety function.

- ▶ Make sure that downstream contactors are monitored (external device monitoring, EDM).

Requirements for the electrical control of the machine

- Use the control without test pulses. The safety switch is self-testing.
- The safety switch tests the OSSDs at regular intervals. To do this, it switches each OSSD briefly (for max. 1 ms) to the OFF state and checks whether this channel is voltage-free during this time.
Make sure that the machine's control does not react to these test pulses and the machine does not switch off.
- The inputs of a connected evaluation unit must be positive-switching (PNP), as the two outputs of the safety switch send a level of the supply voltage in the switched-on state.

The OSSDs are short-circuit protected to 24 V DC and 0 V. When the actuator is in the sensor's response range, the OSSDs signal the ON state with the HIGH signal level (non-isolated). If the actuator is removed from the sensor's response range or there is a device fault, the OSSDs signal the OFF state with the LOW signal level.

The safety switch complies with the regulations for electromagnetic compatibility (EMC) for the industrial sector (Radio Safety Class A). Radio interference cannot be ruled out when used in residential areas.

**DANGER**

Hazard due to lack of effectiveness of the protective device

In the case of non-compliance, it is possible that the dangerous state of the machine may not be stopped or not stopped in a timely manner.

- ▶ Make sure that the following control and electrical requirements are met so the safety switch can fulfill its protective function.

- The external voltage supply of the safety switch must be capable of buffering brief power failures of 20 ms as specified in IEC 60204-1.
- The power supply unit must provide safe isolation according to IEC 61140 (SELV/PELV). Suitable power supply units are available as accessories from SICK.

4.4.2 Application diagnostic output

The application diagnostic output signal changes as soon as the actuator is moved into or leaves the response range of the safety switch. In other words, it does so when the moving protective device is opened and closed. This is not a safety output.

Actuator	Application diagnostic output
Actuator not in response range.	ON
Actuator in response range.	OFF

Table 1: Application diagnostic output switching behavior

4.4.3 Cascading

Cascading makes it possible to connect multiple safety switches. The connected devices act like a single device. Cascading is only possible with the variant that includes the 8-pin M12 male connector.

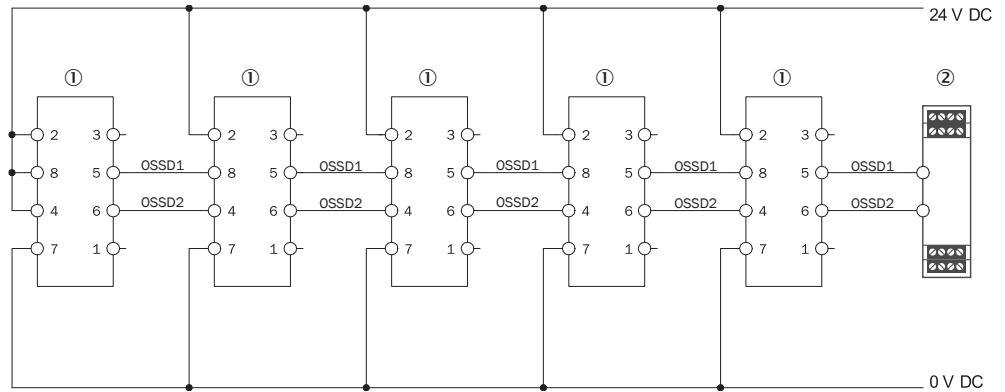

Figure 3: Circuit with 5 cascaded safety switches

- ① Safety switch
- ② Safe evaluation unit

It is not possible to use more than 30 safety switches in a cascade.

The maximum number of safety switches depends on the following factors:

- Applied supply voltage
- Length of cables used
- Cross-section of cables used

The voltage drop in the cascade must be checked to ensure that the defined minimum voltage is still present at the last safety switch.

In the case of connection cables with a length of 2 m and a cable cross-section of 0.25 mm², the maximum number of cascadable safety switches is relative to the voltage, as explained below:

Voltage	Connection cables, the same kind for the entire cascade	Input voltage at 30th safety switch	Maximum number of cascadable safety switches
24 V	Length: 2 m	17.8 V	24
26.8 V	Cable cross-section: 0.25 mm ²	19.2 V	30

Table 2: Maximum number of cascadable safety switches relative to the voltage

The number of safety switches in a cascade affects the response time of the system (see "Response time and enable time in cascade", page 39).

The cascade can be created using special T-pieces and an end connector (see "Connecting a cascade", page 25).



NOTE

In the case of safety switches cascaded using T-connectors, it is not possible to evaluate the application diagnostic output.

4.5 Thorough check concept

Thorough checks must be performed on the safety switch by appropriately qualified safety personnel during commissioning, after modifications, and at regular intervals. [see "Thorough check", page 29](#)

Regular thorough checks serve to investigate the effectiveness of the safety switch and discover defects resulting from modifications or external influences (such as damage or manipulation).

The manufacturer and operating entity must define the type and frequency of the thorough checks on the machine on the basis of the application conditions and the risk assessment. The process of defining the thorough checks must be documented in a traceable manner.

4.5.1 Minimum requirements for regular thorough checks

The following thorough checks must be carried out at least once a year:

- Thorough check of the principal protective function of the safety switch
- Thorough check of the safe sensing range S_{ar}
- Thorough check for damage on the switch housing
- Thorough check for damage on the switch cables
- Thorough check for signs of misuse or manipulation on the safety switch

5 Mounting

5.1 Safety



DANGER

Hazard due to unexpected starting of the machine

Death or severe injury

- ▶ Make sure that the dangerous state of the machine is and remains switched off.



DANGER

Bypassing the protective device

Hazard due to lack of effectiveness of the protective device

- ▶ Prevent incentives to manipulate the safety switch by taking at least one of the following measures:
 - Universally coded variant only: Attach safety switches with a cover or with shielding, or ensure they are out of reach.
 - If possible, use non-detachable mounting methods for actuators (such as welding, gluing, non-removable screws, or rivets).



NOTICE

Incorrect mounting and unsuitable ambient conditions may damage the safety switch.

- ▶ Arrange the sensor and actuator in a way that prevents damage from foreseeable external influences.
- ▶ Do not use the sensor and actuator as a stop.
- ▶ The holder and mounting method for the sensor and actuator must be stable enough to ensure that correct operation can take place.
- ▶ Always use reliable mounting elements that can only be removed using tools.
- ▶ If misalignment results in an opening on the physical guard, this must not impair the protection that is provided.

5.2 Unpacking

- ▶ Check the components for completeness and the integrity of all parts, see "[Scope of delivery](#)", page 40.
- ▶ Please contact your respective SICK subsidiary should you have any complaints.

5.3 Possible mounting types

	Front actuation	Side actuation
"Standard" actuator		
Safe switch on distance S_{ao}	$\leq 10 \text{ mm}$	$\leq 6 \text{ mm}$
Safe switch off distance S_{ar}	$\leq 25 \text{ mm}$	

Table 3: Safe switch-on range based on actuator, alignment, and approach direction

	Front actuation	Side actuation
Switch-on behavior with "Standard" actuator relative to direction of approach	 <p>Peripheral zones with parallel approach. Minimum distance: 6 mm</p>	 <p>No peripheral zones. No minimum distance with parallel approach</p>
"Flat" actuator		
Safe switch on distance S_{a0}	≤ 14 mm	≤ 9 mm
Safe switch off distance S_{ar}	≤ 28 mm	
"Mini" actuator		
Safe switch on distance S_{a0}	≤ 14 mm	≤ 9 mm
Safe switch off distance S_{ar}	≤ 28 mm	
Switch-on behavior with "Flat" or "Mini" actuator relative to direction of approach	 <p>Peripheral zones with parallel approach. Minimum distance: 10 mm</p>	 <p>Peripheral zones with parallel approach. Minimum distance: 4 mm</p>

Table 3: Safe switch-on range based on actuator, alignment, and approach direction

**NOTE**

If the actuator does not move directly onto the sensor when the protective device is closed, but instead approaches it in a parallel position, the specified minimum distance must be adhered to. This prevents the sensor from enabling the safety outputs despite the protective device not being fully closed.

5.4 Mounting

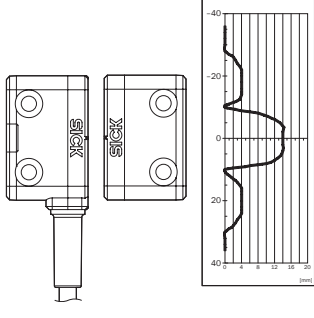
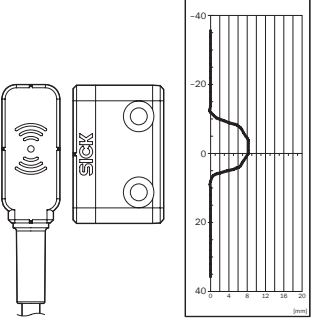
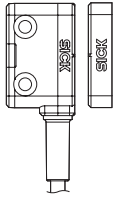
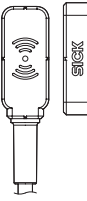
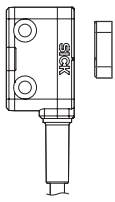
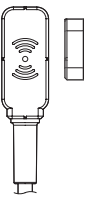
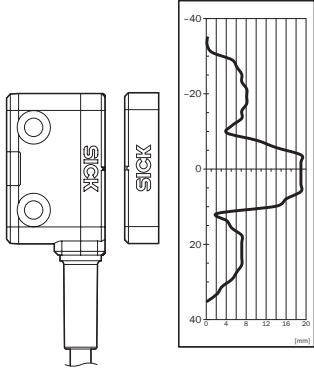
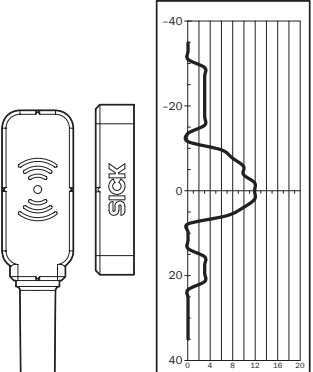
Selecting the mounting location

If the machine documentation does not specify the mounting location, select one carefully:

- ▶ When the protective device is closed, the sensor and actuator must face each other at the safe switch on distance of S_{a0} or closer (see table 3).
- ▶ Select a mounting location that allows the sensor and actuator to be accessed for maintenance work and protects them against damage.
- ▶ If possible, mount the sensor and actuator on non-ferrous subsurfaces and at a distance from metallic parts in order to avoid affecting the sensing range. If this is not possible, the effect on the safe switch on distance S_{a0} and the safe switch off distance S_{ar} must be checked.
- ▶ Make sure that there is no possibility of hazards arising when the protective device is opened, even if the actuator has not yet reached the safe switch off distance S_{ar} .
- ▶ If the actuator is approaching the sensor in a parallel position, observe the minimum distances (see table 3).
- ▶ If necessary, attach an additional stop for the moving protective device.

Mounting the sensor

1. Mount the sensor on the fixed part of the protective device.
2. Take account of the tightening torque for the fixing screws: 1 Nm

Mounting the actuator

1. Align the actuator using the marking notches on the sensor.

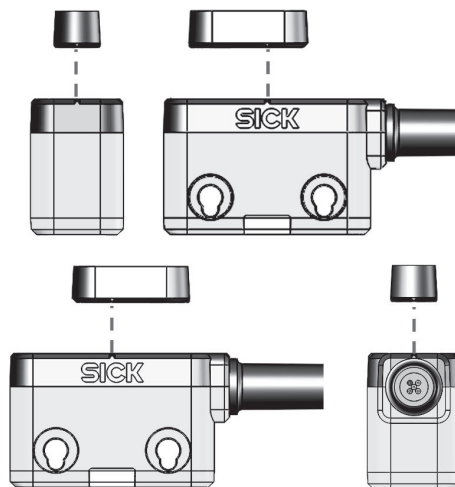

Figure 4: Aligning the actuator on the sensor

2. If you are mounting using fixing screws, take account of the tightening torque for the screws:
 - “Standard” and “Flat” actuators: 1 Nm
 - “Mini” actuator: 0.7 Nm

Mounting multiple safety switches

1. When mounting multiple safety switches, adhere to the specified minimum distance between the individual systems in order to avoid mutual interference.

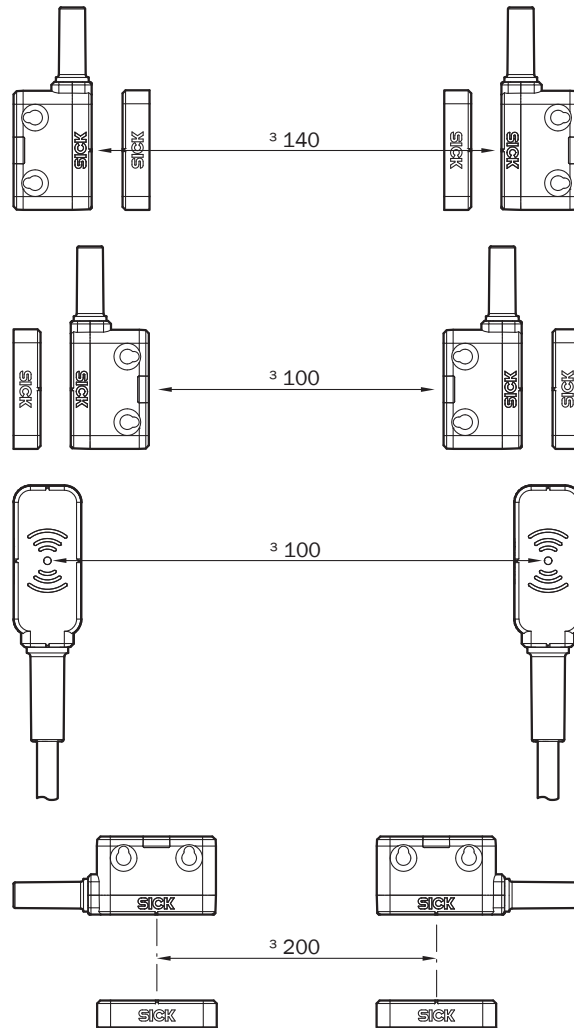

Figure 5: Minimum distances relative to the alignment of the safety switches

6 Electrical installation

6.1 Safety



DANGER

Hazard due to electrical voltage

Hazard due to unexpected starting of the machine

- ▶ Make sure that the machine is and remains disconnected from the power supply during the electrical installation.
 - ▶ Make sure that the dangerous state of the machine is and remains switched off during electrical installation.
 - ▶ Make sure that the outputs of the safety switch have no effect on the machine during electrical installation.
-



DANGER

Incorrect safety switch connection

Loss of safety function

- ▶ When using insulation material or stranded connection wires, make sure they demonstrate the required temperature resistance and mechanical load capability.
 - ▶ Use only safe contacts for safety functions.
-

- ▶ Use a suitable voltage supply. Voltage must be supplied in accordance with SELV/ PELV (IEC 60204-1) for all devices that are electrically connected to the safety switch.
 - ▶ All devices that are electrically connected to the safety switch must have the same voltage supply.
 - ▶ Use protected cable routing to eliminate cross-circuits and short-circuits.
 - ▶ Power devices (such as motors) that represent a strong source of interference must be kept isolated from circuits for signal processing. Route the cables for the safety circuits as far away as possible from the power circuit cables.
 - ▶ Make sure that 1 A fuse protection is provided for safety switches.
 - ▶ Make sure that all electrical outputs have an adequate suppressor to accommodate inductive loads. For this purpose, the outputs must be protected with an appropriate suppressor such as a freewheeling diode, a varistor, or an RC element.
-



DANGER

Hazard due to lack of effectiveness of the protective device

The dangerous state may not be stopped in the event of non-compliance.

- ▶ Operate safety switches within the specifications. If you operate them outside the specifications, this may result in the sensor temperature increasing and in a loss of the safety function.
 - ▶ Make sure that a current of no more than 100 mA is flowing at safety outputs OSSD 1 and OSSD 2. Otherwise, it is no longer possible to guarantee the safety function.
-

**DANGER**

Hazard due to lack of effectiveness of the protective device

The dangerous state may not be stopped in the event of non-compliance.

- ▶ Always connect the two OSSDs separately. The two OSSDs must not be connected to each other.
- ▶ Connect the OSSDs such that the machine controller processes both signals separately.

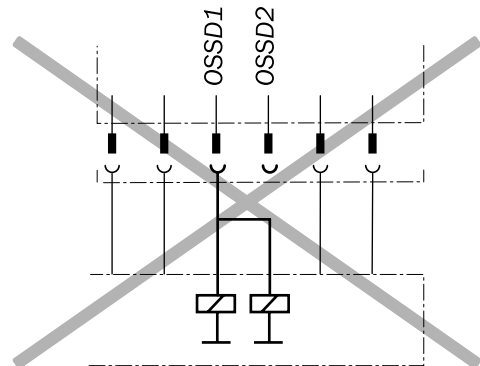
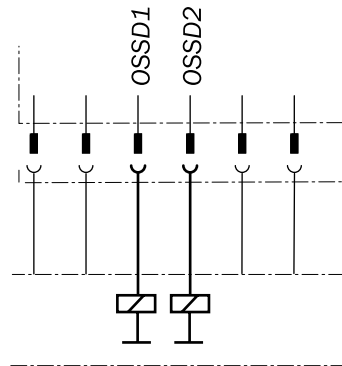
**DANGER**

Hazard due to lack of effectiveness of the protective device

The dangerous state may not be stopped in the event of non-compliance.

- ▶ Prevent the formation of a potential difference between the load and the protective device.
- ▶ If you connect loads to the OSSDs (safety outputs) that then also switch if controlled with negative voltage (e.g., electro-mechanical contactor without reverse polarity protection diode), you must connect the 0 V connections of these loads and those of the corresponding protective device individually and directly to the same 0 V terminal strip. In the event of a fault, this is the only way to ensure that there can be no potential difference between the 0 V connections of the loads and those of the corresponding protective device.

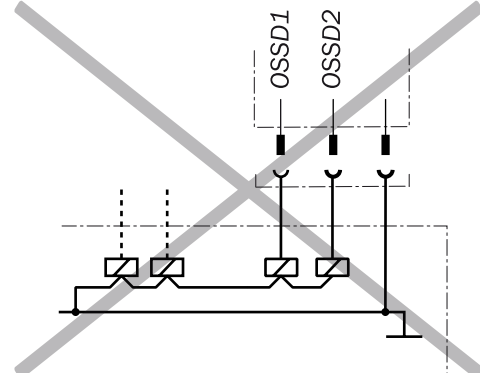
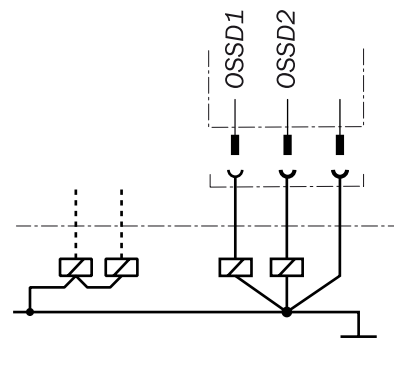

6.2 Notes on cULus

The following conditions must also be fulfilled in order to use and apply the equipment in accordance with UL 508 requirements:

- The voltage supply must conform to Class 2 according to UL 508.
- Connections In 1 and In 2 must conform to Class 2 according to UL 508.
- The device must have 1 A fuse protection.

6.3 Device connection (flying leads)

Wire color	Designation	Description
Brown	+24 V DC	24 V DC voltage supply
White	OSSD 1	Output OSSD 1
Blue	0 V	0 V DC voltage supply
Black	OSSD 2	Output OSSD 2
Gray	Aux	Application diagnostic output (not safe)

Table 4: Device connection cable assignment

6.4 Device connection (M12, 5-pin)

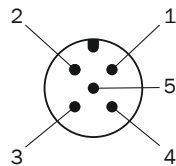

Figure 6: Device connection (male connector, M12, 5-pin, A-coded)

Pin	Wire color ¹⁾	Designation	Description
1	Brown	+24 V DC	24 V DC voltage supply
2	White	OSSD 1	Output OSSD 1
3	Blue	0 V	0 V DC voltage supply
4	Black	OSSD 2	Output OSSD 2
5	Gray	Aux	Application diagnostic output (not safe)

Table 5: Device connection pin assignment (male connector, M12, 5-pin, A-coded)

¹⁾ Applies to the extension cables recommended as accessories.

- ▶ Ensure the plug connector is tightly connected.

6.5 Device connection (M12, 8-pin)

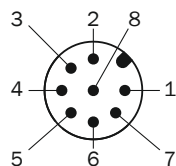

Figure 7: Device connection (male connector, M12, 8-pin, A-coded)

Pin	Wire color ¹⁾	Designation	Description
1	White	Aux	Application diagnostic output (not safe)
2	Brown	+24 V DC	24 V DC voltage supply

Table 6: Device connection pin assignment (male connector, M12, 8-pin, A-coded)

Pin	Wire color ¹⁾	Designation	Description
3	Green	N.C.	Not connected
4	Yellow	In 2	Input OSSD 2 ²⁾
5	Gray	OSSD 1	Output OSSD 1
6	Pink	OSSD 2	Output OSSD 2
7	Blue	0 V	0 V DC voltage supply
8	Red	In 1	Input OSSD 1 ²⁾

Table 6: Device connection pin assignment (male connector, M12, 8-pin, A-coded)

¹⁾ Applies to the extension cables recommended as accessories.

²⁾ When used as a single safety switch or as the first safety switch in a cascade: apply 24 V DC (see "Connecting a cascade", page 25).

- Ensure the plug connector is tightly connected.

6.6 Connecting a cascade

Structure of a cascade

The cascade can be created using special T-connectors and an end connector (see "Accessories", page 43).

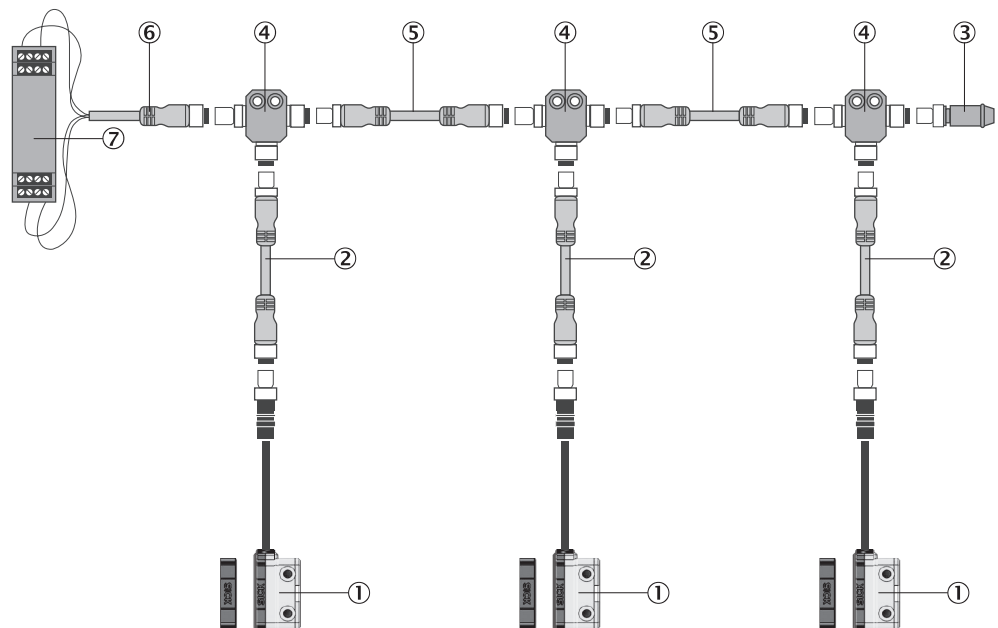

Figure 8: Cascading multiple safety switches

- ① STR1 safety switch
- ② M12 connection cable, 8-pin
- ③ End connector
- ④ T-piece
- ⑤ M12 connection cable, 4-pin
- ⑥ M12 connecting cable, 4-pin
- ⑦ Safe evaluation unit

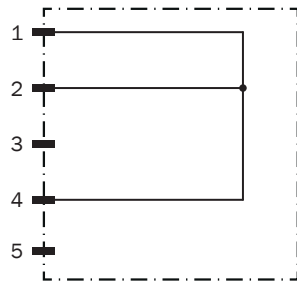

Figure 9: Internal circuitry: end connector for cascade

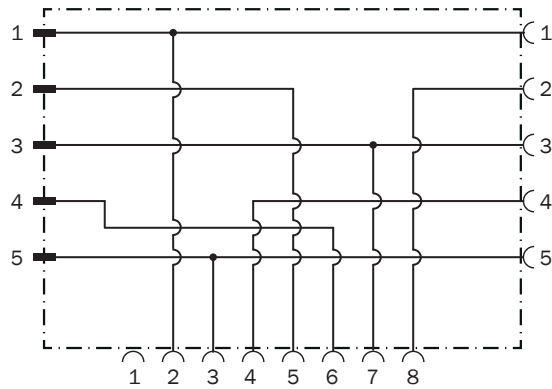

Figure 10: Internal circuitry: T-piece for cascade



DANGER

Bypassing the protective device

The dangerous state may not be stopped in the event of non-compliance.

If the cascade is created using T-pieces, install the connecting cables in a way that prevents a single T-piece (and therefore a safety switch) from simply being jumped.



NOTE

In the case of safety switches cascaded using T-connectors, it is not possible to evaluate the application diagnostic output.



NOTE

If special T-pieces and end connectors are not being used to create the cascade, make sure that inputs In 1 and In 2 are connected to a constant 24 V DC at the first safety switch in the cascade.

Cascade connection (M12, 5-pin)

The 5-pin male connector of the last T-piece before the safe evaluation unit is the interface between the cascade and the safe evaluation unit.

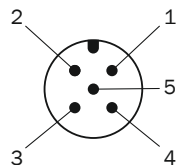

Figure 11: Cascade connection (M12, 5-pin, A-coded, male connector)

Pin	Wire color ¹⁾	Designation	Description
1	Brown	+24 V DC	24 V DC voltage supply
2	White	OSSD 1	Output OSSD 1
3	Blue	0 V	0 V DC voltage supply
4	Black	OSSD 2	Output OSSD 2
5	Gray	N.C.	Not connected

Table 7: Cascade connection pin assignment (male connector, M12, 5-pin, A-coded)

¹⁾ Applies to the extension cables recommended as accessories.

7 Commissioning

7.1 Safety

**DANGER**

Hazard due to lack of effectiveness of the protective device

In the case of non-compliance, it is possible that the dangerous state of the machine may not be stopped or not stopped in a timely manner.

1. Have qualified safety personnel perform a thorough check on the machine and approve it before commissioning.
2. Make sure that the time for the safety requirement (closing the protective device again) is longer than the risk time.

7.2 Switching on

The device initializes after switching on. During this process, the OSSDs are switched off and the light emitting diodes light up alternately in the color sequence green, red, and yellow. For unique coded and permanently coded safety switches only: If any actuators have already been taught in, the STATE light emitting diode will flash once after initialization for each taught-in actuator.

7.3 Teach-in

**DANGER**

Bypassing the protective device

The dangerous state may not be stopped in the event of non-compliance.

- ▶ If an actuator is taught in, document this
- ▶ During regular thorough checks, make sure that the taught-in actuator is still being used.

Variant for universally coded actuators

No teach-in is required.

Variant for unique coded actuators

An actuator must be taught in during commissioning. Up to 8 actuators may be taught in one after the other. Only the most recently taught-in actuator is valid. Previously taught-in actuators cannot be taught in again.

Variant for permanently coded actuators

An actuator must be taught in during commissioning. It is not possible to teach in any further actuators.

Teaching in an actuator

1. Open the physical guard.
2. Connect the safety switch to the voltage supply (see "Electrical installation", page 22).
- ✓ The start sequence is performed. The LEDs light up alternately in the color sequence green, red, and yellow.
3. Close the physical guard.
- ✓ When the guard is closed and the actuator has reached the appropriate position, the safety switch will automatically start the teach-in sequence. The LEDs will dis-

play the individual steps.





STATE light emitting diode (red/green)	DIAG light emitting diode (yellow)	Step
 green	 yellow	Actuator is being taught in
 green	 yellow	Actuator has been taught in

Table 8: Displays for teach-in sequences

4. Within 5 minutes of successfully teaching in the actuator, connect and restore the voltage supply for the safety switch.
- ✓ Once the taught-in actuator is in the response range, both OSSDs switch to the ON state and the STATE light emitting diode lights up green.



NOTE

Actuators can only be taught in at cascaded safety switches if voltage is present at inputs In 1 and In 2. For this purpose, the actuators must be taught in individually in a specific order. Viewed from the evaluation unit, teach-in starts at the last safety switch in the cascade (STATE light emitting diode lights up red, DIAG light emitting diode is off). Then the actuator is taught in at the second-to-last safety switch in the cascade, and so on.

7.4 Thorough check

Requirements for the thorough check during commissioning and in certain situations

The protective device and its application must be thoroughly checked in the following situations:

- Before commissioning
- After changes to the configuration or the safety function
- After changes to the mounting, the alignment, or the electrical connection
- After exceptional events, such as after a manipulation has been detected, after modification of the machine, or after replacing components

The thorough check ensures the following:

- Compliance with all relevant regulations and effectiveness of the protective device for all of the machine’s operating modes.
- The documentation corresponds to the state of the machine, including the protective device

The thorough checks must be carried out by qualified safety personnel or specially qualified and authorized personnel and must be documented in a traceable manner.

1. Check whether the protective device of the machine is effective in all operating modes in which the machine can be set.
2. Make sure that the operating personnel have been instructed in the function of the protective device before starting work on the machine. The instruction is the responsibility of the machine operator and must be carried out by qualified personnel.

8 Troubleshooting

8.1 Safety



DANGER

Hazard due to lack of effectiveness of the protective device

In the case of non-compliance, it is possible that the dangerous state of the machine may not be stopped or not stopped in a timely manner.

- ▶ Immediately put the machine out of operation if the behavior of the machine cannot be clearly identified.
- ▶ Immediately put the machine out of operation if you cannot clearly identify or allocate the fault and if you cannot safely remedy the fault.
- ▶ Secure the machine such that it cannot be switched on unintentionally.



DANGER

Hazard due to unexpected starting of the machine

- ▶ When any work is taking place, use the protective device to secure the machine or to ensure that the machine is not switched on unintentionally.



DANGER

Hazard due to lack of effectiveness of the protective device

In the case of non-compliance, it is possible that the dangerous state of the machine may not be stopped or not stopped in a timely manner.

- ▶ Do not carry out any repairs on the device components.
- ▶ Do not make any modifications to or manipulate the device components.
- ▶ Apart from during the procedures described in this document, the device components must not be opened.



NOTE

If you cannot remedy the fault with the help of the information provided in this chapter, please contact your respective SICK subsidiary.

8.2 Diagnostic LEDs

8.2.1 Switching on

STATE light emitting diode (red/green)	DIAG light emitting diode (yellow)	Duration
● green	○	500 ms
● red	○	500 ms
○	● yellow	500 ms
● green ¹⁾	○	

Table 9: LED displays during initialization

¹⁾ For unique coded and permanently coded safety switches only: If any actuators have already been taught in, the STATE light emitting diode will flash once after initialization for each taught-in actuator.

8.2.2 State display

STATE light emitting diode (red/green)	DIAG light emitting diode (yellow)	Meaning
○	○	No voltage supply
● red	○	No valid actuator in response range. OSSD pair in OFF state
● green	○	Actuator in response range. OSSD pair in ON state
● red	⦿ yellow	Signal at OSSD inputs In 1 and In 2 invalid or not present. OSSD pair in OFF state

8.2.3 Fault displays

STATE light emitting diode (red/green)	DIAG light emitting diode (yellow)	Possible cause	Corrective measure
○	○	No voltage supply	Check voltage supply. If the light emitting diodes do not light up even if a voltage supply is present, replace the safety switch.
⦿ red	⦿ yellow	External fault	<ul style="list-style-type: none"> Check OSSD 1 and OSSD 2 for short-circuit downstream of 0 V or 24 V DC, or between one another Check cabling for damage. There must be a dual-channel configuration.
⦿ red	○	Internal fault	<ul style="list-style-type: none"> Isolate the faulty sensor and check it separately Check wiring for cross-circuits and short-circuits. Switch the voltage supply off and on. If the fault still occurs after this, the sensor is defective. Replace sensor.

Table 10: Fault displays

8.2.4 Fault displays in cascading

If a fault affects a device in a cascade, the device in question displays the fault and switches off the OSSDs (STATE light emitting diode flashes red). All downstream devices switch off their OSSDs (STATE light emitting diode lights up red, DIAG light emitting diode flashes yellow).

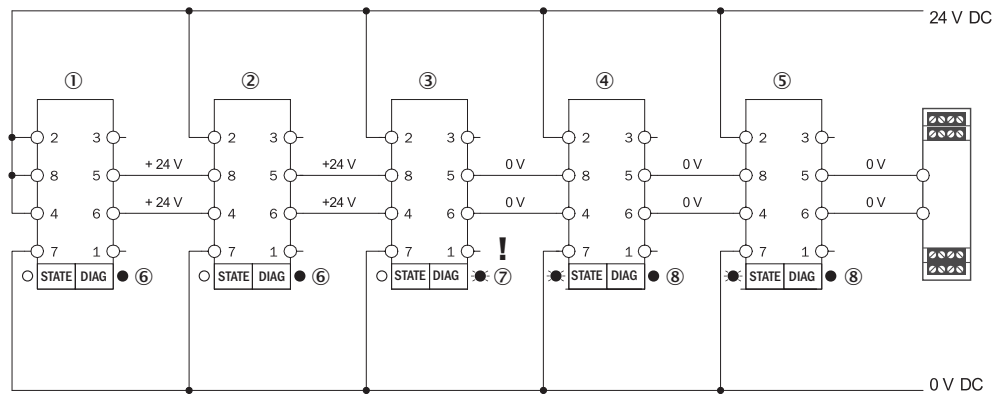

Figure 12: Fault displays on cascaded safety switches. The example shows an internal fault at safety switch 3

- ① – ⑤ Safety switch
- ⑥ Light emitting diode lights up green
- ⑦ Light emitting diode flashes red
- ⑧ Light emitting diode lights up red

What to do in the event of a fault affecting cascaded safety switches:

- Isolate the faulty sensor and check it separately.
- Check wiring for cross-circuits and short-circuits.
- Switch the voltage supply off and on. If the fault still occurs after this, the sensor is defective. Replace sensor.

8.2.5 Fault displays during teach-in

STATE light emitting diode (red/green)	STATE light emitting diode (yellow)	Cause
☀️ red/green	☀️ yellow	The maximum number of actuators has been taught in. It is not possible to carry out another teach-in process.
☀️ red/green	● yellow	An actuator that has already been taught in needs to be taught in again. This is not possible.
☀️ red/green	○	Teach-in sequence failed. Teach in the actuator again. Possible fault: <ul style="list-style-type: none"> • Actuator removed from response range too early. • Voltage supply not isolated in a timely manner.

Table 11: Fault displays during teach-in

Fault displays are repeated until the equipment is reset.

- ▶ To perform a reset, disconnect the voltage supply for at least 3 s.

9 Maintenance

9.1 Cleaning

**NOTICE**

- ▶ Do not use aggressive cleaning agents.
 - ▶ Do not use any substances that hinder the wetting properties of lacquers.
 - ▶ We recommend anti-static cleaning agents.
-

9.2 Regular thorough check

The safety switch must be thoroughly checked regularly. The type and frequency of thorough checks are defined by the manufacturer and the operating entity of the machine; see ["Thorough check concept", page 17](#)

Regular thorough checks serve to investigate the effectiveness of the safety switch and detect any ineffectiveness due to modifications or external influences (such as damage or manipulation).

1. Carry out the thorough checks according to the instructions from the manufacturer and the operating entity of the machine.

10 Decommissioning

10.1 Protection of the environment

The safety switch has been designed to minimize its impact on the environment. It uses a minimum of energy and resources.

- ▶ Always act in an environmentally responsible manner at work. For this reason, please note the following information regarding disposal.

10.2 Disposal

Always dispose of serviceableness devices in compliance with local/national rules and regulations with respect to waste disposal.



NOTE

We would be pleased to be of assistance on the disposal of this device. Contact us.

11 Technical data

11.1 Technical data

Features			
	“Standard” actuator	“Flat” actuator	“Mini” actuator
Safe switch on distance S_{ao} (IEC 60947 5-3)			
Front actuation	10 mm	14 mm	14 mm
Side actuation	6 mm	9 mm	9 mm
Typical switch on distance			
Front actuation	14 mm	19 mm	19 mm
Side actuation	8 mm	12 mm	12 mm
Safe switch off distance S_{ar}	25 mm	28 mm	28 mm
Max. actuation frequency	0.5 Hz		
Cascading	≤ 30 safety switches		

Table 12: Features

Safety-related parameters	
Performance level	PL e (EN ISO 13849-1)
Category	4 (EN ISO 13849)
Safety integrity level	SIL 3 (EN 61508)
SIL claim limit	SILCL 3 (EN 62061)
PFHd (mean probability of a dangerous failure per hour)	5.21 × 10 ⁻⁹ at 40 °C and mean sea level 14 × 10 ⁻⁹ at 40 °C and 2,000 m
T_M (mission time)	20 years (EN ISO 13849-1)
Response time (removal from response range)	≤ 40 ms
Enable time (reaction time when approaching response range)	≤ 100 ms
Risk time ¹⁾²⁾	≤ 80 ms
Length of cable ³⁾	≤ 200 m
Minimum distance between 2 safety switches	Dependent on alignment see "Mounting", page 20
Type	Type 4 (EN ISO 14119)
Coding level	
Universally coded	Low coding level (EN ISO 14119)
Unique coded	High coding level (EN ISO 14119)
Permanently coded	High coding level (EN ISO 14119)
Safe state when a fault occurs	At least one OSSD is in the OFF state

Table 13: Safety-related parameters

- 1) At least one of the two OSSD outputs is safely switched off within the reaction time.
- 2) The risk time is the fault detection time in the case of internal or external faults. External faults affect the OSSDs (short-circuit to an OSSD or cross-circuit between the two OSSDs). At least one of the two OSSDs is safely switched off within the risk time.
- 3) The length of cable and the cable cross-section change the voltage drop according to the output current ($R_{max} = 14.5 \Omega$).

Interfaces	
System connection	
Voltage supply Local inputs and outputs	Male connector, M12, 5-pin, A-coded (common male connector for voltage supply and outputs) or Male connector, M12, 8 pin, A-coded (common male connector for voltage supply and inputs and outputs) or Flying leads
Length of connecting cable	3 m or 10 m

Table 14: Interfaces

Electrical data	
OSSD pairs	1
Rated impulse withstand voltage U_{imp}	1,500 V
Pollution degree	3 (external, according to EN 60947-1)
Power-up delay (after supply voltage is applied) ¹⁾	2.5 s
Supply voltage V_s	24 V DC (19.2 V ... 28.8 V)
Rated insulation voltage U_i	32 V DC
Cable capacitance	400 nF (for Out A and Out B) 2 µF (for Out Aux)
Device fuse protection	1 A
Current consumption (without load)	50 mA
Protection class	III (EN 61140/IEC 61140)

Table 15: Electrical data

- ¹⁾ Once the supply voltage is switched on, the OSSDs and the application diagnostic output will be in the OFF state during the time delay before availability. The specified time applies to one sensor; in a cascade, 0.1 s is added for each sensor. In the case of unique coded and permanently coded sensors, an additional 0.5 s must be added per taught-in actuator.

Mechanical data	
Dimensions (W x H x D)	
Safety switch "Standard" actuator "Flat" actuator "Mini" actuator	40 mm x 18 mm x 26 mm see figure 15 see figure 16 see figure 17
Material	
Sensor Actuator	Vistal® Vistal®
Weight	
Safety switch "Standard" actuator "Flat" actuator "Mini" actuator	63 g ... 436 g (depending on variant) 26 g 13 g 6 g

Table 16: Mechanical data

Inputs	
Rated voltage	24 V DC (19,2 V ... 28,8 V)

Table 17: Inputs

Inputs	
Switching current	
ON state	≤ 5 mA
OFF state	0 mA
Switching voltage	
ON state	21 V DC ... 24 V DC
OFF state	≤ 2 V DC

Table 17: Inputs

Outputs	
2 OSSDs (Out 1 and Out 2)	2 x PNP, 100 mA max., short-circuit protected and overload-proof
Application diagnostic output (Aux)	50 mA max., short-circuit protected
Switching current	
ON state	≤ 100 mA
OFF state	< 500 µA
Switching voltage	
ON state	21 V DC ... 24 V DC
OFF state	0 V DC ... 2 V DC

Table 18: Outputs

Ambient data	
Enclosure rating	IP 67 (IEC 60529)
Ambient operating temperature	-10 °C ... +70 °C
Storage temperature	-25 °C ... +70 °C
Vibration resistance	1 mm/10 Hz ... 55 Hz (IEC 60068-2-6)
Shock resistance	30 g, 11 ms (IEC 60068-2-27)
EMC	According to IEC/EN 61326-3-1, IEC/EN 60947-5-2, and IEC/EN 60947-5-3

Table 19: Ambient data

11.2 Dimensional drawings

Sensor

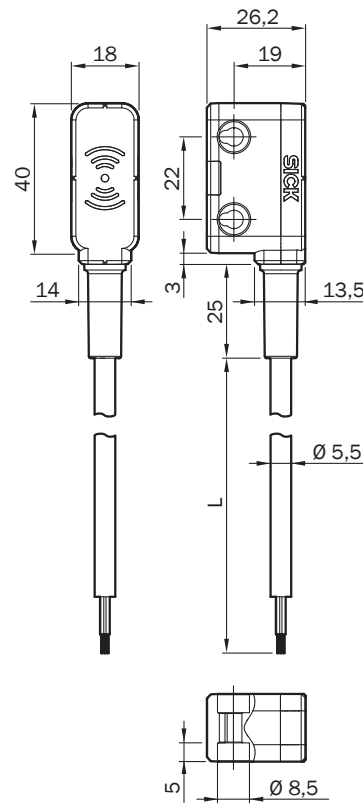
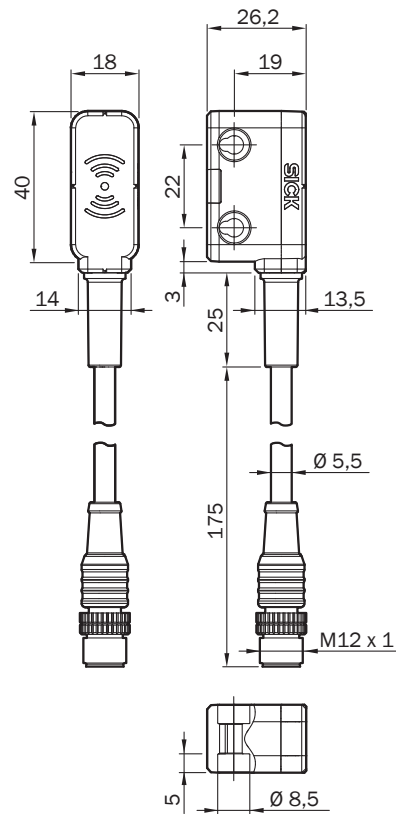

Figure 13: Dimensional drawing for STR1 sensor with M12 male connector

Figure 14: Dimensional drawing for STR1 sensor with flying leads

Actuator

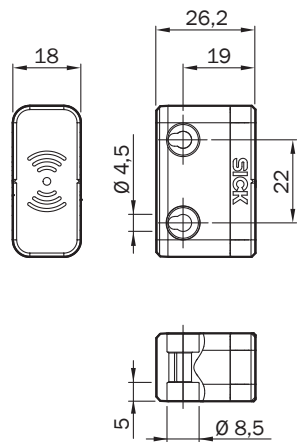

Figure 15: STR1 dimensional drawing, "Standard" actuator

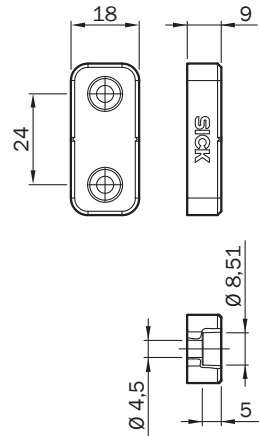

Figure 16: STR1 dimensional drawing, "Flat" actuator

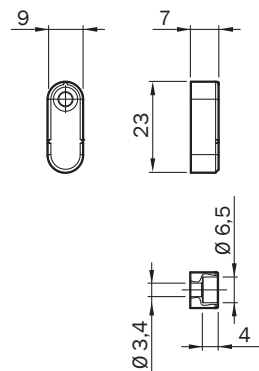

Figure 17: STR1 dimensional drawing, "Mini" actuator

11.3 Response time and enable time in cascade

The reaction times are subject to the following parameters:

- Response time or enable time
- Number of cascaded devices

Response time (removal of actuator from response range)

Response time for cascade: $40 \text{ ms} + 80 \text{ ms} * \text{number of safety switches in cascade}$

Enable time (actuator approaching response range)

Enable time for cascade: $100 \text{ ms} + 80 \text{ ms} * \text{number of safety switches in cascade}$

12 Ordering information

12.1 Scope of delivery

- Sensor
- Actuator
- Safety note
- Operating instructions for download: www.sick.com

12.2 STR1 ordering information

Actuator	Sensor connection type	Type code	Part number
Flat	Cable with male connector, M12, 5-pin	STR1-SAFM0AC5	1069565
	Cable with male connector, M12, 8-pin	STR1-SAFM0AC8	1069566
	Cable, 5-wire, 3 m	STR1-SAFM03P5	1069567
	Cable, 5-wire, 10 m	STR1-SAFM10P5	1069568
Standard	Cable with male connector, M12, 5-pin	STR1-SASM0AC5	1069560
	Cable with male connector, M12, 8-pin	STR1-SASM0AC8	1069561
	Cable, 5-wire, 3 m	STR1-SASM03P5	1069562
	Cable, 5-wire, 10 m	STR1-SASM10P5	1069563
Mini	Cable with male connector, M12, 5-pin	STR1-SAMM0AC5	1069570
	Cable with male connector, M12, 8-pin	STR1-SAMM0AC8	1069571
	Cable, 5-wire, 3 m	STR1-SAMM03P5	1069572
	Cable, 5-wire, 10 m	STR1-SAMM10P5	1069573

Table 20: STR1 ordering information, universally coded

Actuator	Sensor connection type	Type code	Part number
Flat	Cable with male connector, M12, 5-pin	STR1-SAFU0AC5	1069575
	Cable with male connector, M12, 8-pin	STR1-SAFU0AC8	1069576
	Cable, 5-wire, 3 m	STR1-SAFU03P5	1069577
	Cable, 5-wire, 10 m	STR1-SAFU10P5	1072707
Standard	Cable with male connector, M12, 5-pin	STR1-SASU0AC5	1072709
	Cable with male connector, M12, 8-pin	STR1-SASU0AC8	1072710
	Cable, 5-wire, 3 m	STR1-SASU03P5	1072711
	Cable, 5-wire, 10 m	STR1-SASU10P5	1072712

Table 21: STR1 ordering information, unique coded

Actuator	Sensor connection type	Type code	Part number
Mini	Cable with male connector, M12, 5-pin	STR1-SAMU0AC5	1073205
	Cable with male connector, M12, 8-pin	STR1-SAMU0AC8	1073204
	Cable, 5-wire, 3 m	STR1-SAMU03P5	1073201
	Cable, 5-wire, 10 m	STR1-SAMU10P5	1073203

Table 21: STR1 ordering information, unique coded

Actuator	Sensor connection type	Type code	Part number
Flat	Cable with male connector, M12, 5-pin	STR1-SAFF0AC5	1073206
	Cable with male connector, M12, 8-pin	STR1-SAFF0AC8	1073207
	Cable, 5-wire, 3 m	STR1-SAFF03P5	1073208
	Cable, 5-wire, 10 m	STR1-SAFF10P5	1073209
Standard	Cable with male connector, M12, 5-pin	STR1-SASF0AC5	1073211
	Cable with male connector, M12, 8-pin	STR1-SASF0AC8	1073212
	Cable, 5-wire, 3 m	STR1-SASF03P5	1073213
	Cable, 5-wire, 10 m	STR1-SASF10P5	1073214
Mini	Cable with male connector, M12, 5-pin	STR1-SAMF0AC5	1073216
	Cable with male connector, M12, 8-pin	STR1-SAMF0AC8	1073217
	Cable, 5-wire, 3 m	STR1-SAMF03P5	1073218
	Cable, 5-wire, 10 m	STR1-SAMF10P5	1073219

Table 22: STR1 ordering information, permanently coded

13 Spare parts

13.1 Actuator

Type	Type code	Part number
Flat	STR1-XAF	1073221
Standard	STR1-XAS	1073223
Mini	STR1-XAM	1073222

Table 23: Actuator

13.2 Sensors

Coding	Connection type	Type code	Part number
Universally coded	Cable with male connector, M12, 5-pin	STR1-XDAMOAC5	1073224
	Cable with male connector, M12, 8-pin	STR1-XDAMOAC8	1073225
	Cable, 5-wire, 3 m	STR1-XDAM03P5	1073226
	Cable, 5-wire, 10 m	STR1-XDAM10P5	1073227
Unique coded	Cable with male connector, M12, 5-pin	STR1-XDAU0AC5	1073228
	Cable with male connector, M12, 8-pin	STR1-XDAU0AC8	1073230
	Cable, 5-wire, 3 m	STR1-XDAU03P5	1073231
	Cable, 5-wire, 10 m	STR1-XDAU10P5	1073232
Permanently coded	Cable with male connector, M12, 5-pin	STR1-XDAF0AC5	1073233
	Cable with male connector, M12, 8-pin	STR1-XDAF0AC8	1073234
	Cable, 5-wire, 3 m	STR1-XDAF03P5	1073235
	Cable, 5-wire, 10 m	STR1-XDAF10P5	1073236

Table 24: Sensors

14 Accessories

14.1 Connectivity

Connecting cable, M12, 4-pin (0.34 mm²)

Part	Type code	Part number
Female connector straight, 5 m cable, open end	DOL-1204-G05MC	6025901
Female connector straight, 10 m cable, open end	DOL-1204-G10MC	6025902
Female connector straight, 15 m cable, open end	DOL-1204-G15MC	6034749
Female connector straight, 20 m cable, open end	DOL-1204-G20MC	6034750

Table 25: Ordering information for M12 connecting cable, 4-pin (0.34 mm²) ¹⁾

Connecting cable, M12, 5-pin (0.34 mm²)

Part	Type code	Part number
Female connector straight, 2 m cable, open end	DOL-1205-G02MC	6025906
Female connector straight, 5 m cable, open end	DOL-1205-G05MC	6025907
Female connector straight, 10 m cable, open end	DOL-1205-G10MC	6025908

Table 26: Ordering information for M12 connecting cable, 5-pin (0.34 mm²) ¹⁾

Connection cable, M12, 8-pin (0.25 mm²)

Part	Type code	Part number
Female connector straight, 5 m cable, open end	DOL-1208-G05MA	6020993
Female connector straight, 10 m cable, open end	DOL-1208-G10MA	6022152
Female connector straight, 15 m cable, open end	DOL-1208-G15MA	6022153
Female connector straight, 30 m cable, open end	DOL-1208-G30MA	6022242

Table 27: Ordering information for M12 connecting cable, 8-pin (0.25 mm²) ¹⁾

Connection cable, M12, 4-pin (0.25 mm²)

Part	Type code	Part number
Female connector straight, 0.6 m cable, male connector straight	DSL-1204-G0M6	6022565
Female connector straight, 2 m cable, male connector straight	DSL-1204-G02M	6022567
Female connector straight, 5 m cable, male connector straight	DSL-1204-G05M	6022569

Table 28: Ordering information for M12 connection cable, 4-pin (0.25 mm²) ¹⁾

Connection cable, M12, 4-pin (0.34 mm²)

¹⁾ Ambient operating temperature: down to -30 °C with fixed installation.

Part	Type code	Part number
Female connector straight, 0.6 m cable, male connector straight	DSL-1204-G1M5	6034822
Female connector straight, 10 m cable, male connector straight	DSL-1204-G10M	6034406
Female connector straight, 20 m cable, male connector straight	DSL-1204-G20M	6034407

Table 29: Ordering information for M12 connection cable, 4-pin (0.34 mm²) ¹⁾

Connection cable, M12, 8-pin (0.25 mm²)

Part	Type code	Part number
Female connector straight, 1 m cable, male connector straight	DSL-1208-G01MAC	6026625
Female connector straight, 2 m cable, male connector straight	DSL-1208-G02MAC	6030121
Female connector straight, 5 m cable, male connector straight	DSL-1208-G05MAC	6032325
Female connector straight, 10 m cable, male connector straight	DSL-1208-G10MAC	6034901

Table 30: Ordering information for M12 connection cable, 8-pin (0.25 mm²) ¹⁾

Distributor

Part	Type code	Part number
T-piece	TR4-AK004C	5325889

Table 31: Ordering information for distributor

End connector

Part	Type code	Part number
End connector for series connection	TR4-AL002C	5325890

Table 32: Ordering information for end connector

¹⁾ Ambient operating temperature: down to -30 °C with fixed installation.

15 Annex

15.1 Compliance with EU directives

EU declaration of conformity (excerpt)

The undersigned, representing the following manufacturer herewith declares that the product is in conformity with the provisions of the following EU directive(s) (including all applicable amendments), and that the respective standards and/or technical specifications are taken as the basis.

Complete EU declaration of conformity for download

You can call up the EU declaration of conformity and the current operating instructions for the protective device by entering the part number in the search field at www.sick.com (part number: see the type label entry in the "Ident. no." field).

15.2 FCC and IC radio approval

- FCC ID: 2AHDRSTR1
- IC: 21147STR1

The device fulfills the EMC requirements for use in the USA and Canada, in accordance with the following extracts from the relevant approvals:

FCC § 15.19

This device complies with Part 15 of the FCC rules. Operation is subject to the following two conditions:

- This device may not cause harmful interference, and
- this device must accept any interference received, including interference that may cause undesired operation.

FCC §15.21 (warning statement)

[Any] changes or modifications not expressly approved by the party responsible for compliance could void the user's authority to operate the equipment.

IC

This device complies with Industry Canada's licence-exempt RSSs. Operation is subject to the following two conditions:

- This device may not cause interference; and
- This device must accept any interference, including interference that may cause undesired operation of the device.

Le présent appareil est conforme aux CNR d'Industrie Canada applicables aux appareils radio exempts de licence. L'exploitation est autorisée aux deux conditions suivantes :

- l'appareil ne doit pas produire de brouillage;
- l'utilisateur de l'appareil doit accepter tout brouillage radioélectrique subi, même si le brouillage est susceptible d'en compromettre le fonctionnement.

16 List of figures

1.	Dual-channel and isolated connection of OSSD 1 and OSSD 2.....	14
2.	No potential difference between load and protective device.....	14
3.	Circuit with 5 cascaded safety switches.....	16
4.	Aligning the actuator on the sensor.....	20
5.	Minimum distances relative to the alignment of the safety switches.....	21
6.	Device connection (male connector, M12, 5-pin, A-coded).....	24
7.	Device connection (male connector, M12, 8-pin, A-coded).....	24
8.	Cascading multiple safety switches.....	25
9.	Internal circuitry: end connector for cascade.....	26
10.	Internal circuitry: T-piece for cascade.....	26
11.	Cascade connection (M12, 5-pin, A-coded, male connector).....	26
12.	Fault displays on cascaded safety switches. The example shows an internal fault at safety switch 3.....	32
13.	Dimensional drawing for STR1 sensor with M12 male connector.....	38
14.	Dimensional drawing for STR1 sensor with flying leads.....	38
15.	STR1 dimensional drawing, "Standard" actuator.....	38
16.	STR1 dimensional drawing, "Flat" actuator.....	39
17.	STR1 dimensional drawing, "Mini" actuator.....	39

17 List of tables

1. Application diagnostic output switching behavior..... 15

2. Maximum number of cascadable safety switches relative to the voltage..... 16

3. Safe switch-on range based on actuator, alignment, and approach direction..... 18

4. Device connection cable assignment.....24

5. Device connection pin assignment (male connector, M12, 5-pin, A-coded)..... 24

6. Device connection pin assignment (male connector, M12, 8-pin, A-coded)..... 24

7. Cascade connection pin assignment (male connector, M12, 5-pin, A-coded).....27

8. Displays for teach-in sequences..... 29

9. LED displays during initialization..... 30

10. Fault displays..... 31

11. Fault displays during teach-in..... 32

12. Features..... 35

13. Safety-related parameters..... 35

14. Interfaces..... 36

15. Electrical data..... 36

16. Mechanical data..... 36

17. Inputs.....36

18. Outputs.....37

19. Ambient data..... 37

20. STR1 ordering information, universally coded.....40

21. STR1 ordering information, unique coded..... 40

22. STR1 ordering information, permanently coded..... 41

23. Actuator..... 42

24. Sensors..... 42

25. Ordering information for M12 connecting cable, 4-pin (0.34 mm²) 43

26. Ordering information for M12 connecting cable, 5-pin (0.34 mm²) 43

27. Ordering information for M12 connecting cable, 8-pin (0.25 mm²) 43

28. Ordering information for M12 connection cable, 4-pin (0.25 mm²) 43

29. Ordering information for M12 connection cable, 4-pin (0.34 mm²) 44

30. Ordering information for M12 connection cable, 8-pin (0.25 mm²) 44

31. Ordering information for distributor.....44

32. Ordering information for end connector.....44

Australia

Phone +61 3 9457 0600
1800 334 802 - tollfree
E-Mail sales@sick.com.au

Austria

Phone +43 22 36 62 28 8-0
E-Mail office@sick.at

Belgium/Luxembourg

Phone +32 2 466 55 66
E-Mail info@sick.be

Brazil

Phone +55 11 3215-4900
E-Mail marketing@sick.com.br

Canada

Phone +1 905 771 14 44
E-Mail information@sick.com

Czech Republic

Phone +420 2 57 91 18 50
E-Mail sick@sick.cz

Chile

Phone +56 2 2274 7430
E-Mail info@schadler.com

China

Phone +86 20 2882 3600
E-Mail info.china@sick.net.cn

Denmark

Phone +45 45 82 64 00
E-Mail sick@sick.dk

Finland

Phone +358-9-2515 800
E-Mail sick@sick.fi

France

Phone +33 1 64 62 35 00
E-Mail info@sick.fr

Germany

Phone +49 211 5301-301
E-Mail info@sick.de

Hong Kong

Phone +852 2153 6300
E-Mail ghk@sick.com.hk

Hungary

Phone +36 1 371 2680
E-Mail office@sick.hu

India

Phone +91 22 4033 8333
E-Mail info@sick-india.com

Israel

Phone +972 4 6881000
E-Mail info@sick-sensors.com

Italy

Phone +39 02 274341
E-Mail info@sick.it

Japan

Phone +81 3 5309 2112
E-Mail support@sick.jp

Malaysia

Phone +6 03 8080 7425
E-Mail enquiry.my@sick.com

Mexico

Phone +52 472 748 9451
E-Mail mario.garcia@sick.com

Netherlands

Phone +31 30 2044 000
E-Mail info@sick.nl

New Zealand

Phone +64 9 415 0459
0800 222 278 - tollfree
E-Mail sales@sick.co.nz

Norway

Phone +47 67 81 50 00
E-Mail sick@sick.no

Poland

Phone +48 22 539 41 00
E-Mail info@sick.pl

Romania

Phone +40 356 171 120
E-Mail office@sick.ro

Russia

Phone +7 495 775 05 30
E-Mail info@sick.ru

Singapore

Phone +65 6744 3732
E-Mail sales.gsg@sick.com

Slovakia

Phone +421 482 901201
E-Mail mail@sick-sk.sk

Slovenia

Phone +386 591 788 49
E-Mail office@sick.si

South Africa

Phone +27 11 472 3733
E-Mail info@sickautomation.co.za

South Korea

Phone +82 2 786 6321
E-Mail info@sickkorea.net

Spain

Phone +34 93 480 31 00
E-Mail info@sick.es

Sweden

Phone +46 10 110 10 00
E-Mail info@sick.se

Switzerland

Phone +41 41 619 29 39
E-Mail contact@sick.ch

Taiwan

Phone +886 2 2375-6288
E-Mail sales@sick.com.tw

Thailand

Phone +66 2645 0009
E-Mail Ronnie.Lim@sick.com

Turkey

Phone +90 216 528 50 00
E-Mail info@sick.com.tr

United Arab Emirates

Phone +971 4 88 65 878
E-Mail info@sick.ae

United Kingdom

Phone +44 1727 831121
E-Mail info@sick.co.uk

USA

Phone +1 800 325 7425
E-Mail info@sick.com

Vietnam

Phone +84 945452999
E-Mail Ngo.Duy.Linh@sick.com

Further locations at www.sick.com