

Radar Transmitters

SITRANS LR250 (mA/HART)

Operating Instructions · 08/2014



SITRANS

SIEMENS

Safety Guidelines

Warning notices must be observed to ensure personal safety as well as that of others, and to protect the product and the connected equipment. These warning notices are accompanied by a clarification of the level of caution to be observed.

Qualified Personnel

This device/system may only be set up and operated in conjunction with this manual. Qualified personnel are only authorized to install and operate this equipment in accordance with established safety practices and standards.

Unit Repair and Excluded Liability:

- The user is responsible for all changes and repairs made to the device by the user or the user's agent.
- All new components are to be provided by Siemens Milltronics Process Instruments.
- Restrict repair to faulty components only.
- Do not reuse faulty components.

Warning: Cardboard shipping package provides limited humidity and moisture protection. This product can only function properly and safely if it is correctly transported, stored, installed, set up, operated, and maintained.

This product is intended for use in industrial areas. Operation of this equipment in a residential area may cause interference to several frequency based communications.

Note: Always use product in accordance with specifications.

Copyright Siemens AG 2013. All Rights Reserved	Disclaimer of Liability
This document is available in bound version and in electronic version. We encourage users to purchase authorized bound manuals, or to view electronic versions as designed and authored by Siemens Milltronics Process Instruments. Siemens Milltronics Process Instruments will not be responsible for the contents of partial or whole reproductions of either bound or electronic versions.	While we have verified the contents of this manual for agreement with the instrumentation described, variations remain possible. Thus we cannot guarantee full agreement. The contents of this manual are regularly reviewed and corrections are included in subsequent editions. We welcome all suggestions for improvement. Technical data subject to change.

MILLTRONICS® is a registered trademark of Siemens Milltronics Process Instruments.

Contact SMPI Technical Publications at the following address:

Technical Publications
Siemens AG
Siemens Milltronics Process Instruments
1954 Technology Drive, P.O. Box 4225
Peterborough, Ontario, Canada, K9J 7B1
Email: techpubs.smpi@siemens.com

European Authorized Representative

Siemens AG
Industry Sector
76181 Karlsruhe
Deutschland

- For a selection of Siemens Milltronics level measurement manuals, go to: **www.siemens.com/processautomation**. Under Process Instrumentation, select *Level Measurement* and then go to the manual archive listed under the product family.
- For a selection of Siemens Milltronics weighing manuals, go to: **www.siemens.com/processautomation**. Under Weighing Technology, select *Continuous Weighing Systems* and then go to the manual archive listed under the product family.

SIEMENS

SITRANS

Radar Transmitters SITRANS LR250 (mA/HART)

Operating Instructions

Introduction	1
Safety information	2
Description	3
Installing/mounting	4
Connecting	5
Commissioning	6
Remote operation	7
Parameter reference	8
Service and maintenance	9
Diagnosing and troubleshooting	10
Technical data	11
Dimension drawings	12
Appendix A: Technical reference	A
Appendix B: HART communications	B
Appendix C: Certificates and support	C
List of abbreviations	13
LCD menu structure	14

Legal information

Warning notice system

This manual contains notices you have to observe in order to ensure your personal safety, as well as to prevent damage to property. The notices referring to your personal safety are highlighted in the manual by a safety alert symbol, notices referring only to property damage have no safety alert symbol. These notices shown below are graded according to the degree of danger.

DANGER

indicates that death or severe personal injury **will** result if proper precautions are not taken.

WARNING

indicates that death or severe personal injury **may** result if proper precautions are not taken.

CAUTION

indicates that minor personal injury can result if proper precautions are not taken.

NOTICE

indicates that property damage can result if proper precautions are not taken.

If more than one degree of danger is present, the warning notice representing the highest degree of danger will be used. A notice warning of injury to persons with a safety alert symbol may also include a warning relating to property damage.

Qualified Personnel

The product/system described in this documentation may be operated only by **personnel qualified** for the specific task in accordance with the relevant documentation, in particular its warning notices and safety instructions. Qualified personnel are those who, based on their training and experience, are capable of identifying risks and avoiding potential hazards when working with these products/systems.

Proper use of Siemens products

Note the following:

WARNING

Siemens products may only be used for the applications described in the catalog and in the relevant technical documentation. If products and components from other manufacturers are used, these must be recommended or approved by Siemens. Proper transport, storage, installation, assembly, commissioning, operation and maintenance are required to ensure that the products operate safely and without any problems. The permissible ambient conditions must be complied with. The information in the relevant documentation must be observed.

Trademarks

All names identified by ® are registered trademarks of Siemens AG. The remaining trademarks in this publication may be trademarks whose use by third parties for their own purposes could violate the rights of the owner.

Disclaimer of Liability

We have reviewed the contents of this publication to ensure consistency with the hardware and software described. Since variance cannot be precluded entirely, we cannot guarantee full consistency. However, the information in this publication is reviewed regularly and any necessary corrections are included in subsequent editions.

Table of contents

1	Introduction.....	9
1.1	LR250 mA/HART manual usage.....	9
1.2	Purpose of this documentation	9
1.3	Document history	9
1.4	Firmware revision history	10
1.5	Designated use	11
1.6	Checking the consignment.....	11
1.7	Transportation and storage.....	12
1.8	Notes on warranty.....	12
2	Safety information	13
2.1	Preconditions for safe use	13
2.1.1	Safety marking symbols.....	13
2.1.2	Laws and directives	13
2.1.3	FCC Conformity	14
2.1.4	Conformity with European directives	15
2.1.5	CE Electromagnetic Compatibility (EMC) Conformity.....	16
2.2	Improper device modifications	16
2.3	Requirements for special applications	17
2.4	Use in hazardous areas	17
3	Description.....	19
3.1	SITRANS LR250 overview.....	19
3.2	Programming.....	20
3.3	Applications.....	20
3.4	Approvals and certificates	20
4	Installing/mounting	21
4.1	Basic safety information.....	21
4.1.1	Pressure applications.....	22
4.1.1.1	Pressure Equipment Directive, PED, 97/23/EC	23
4.2	Installation location requirements	24
4.3	Proper mounting.....	26
4.3.1	Nozzle design.....	27

4.3.2	Nozzle location	28
4.3.3	Orientation in a vessel with obstructions.....	31
4.3.4	Mounting on a Stillpipe or Bypass Pipe	32
4.3.5	Device orientation	33
4.4	Installation instructions.....	34
4.4.1	Threaded versions	35
4.4.2	Flanged versions.....	35
4.4.3	Hygienic versions	38
4.5	Disassembly.....	39
5	Connecting	41
5.1	Basic safety information	41
5.2	Connecting SITRANS LR250.....	41
5.3	Wiring setups for hazardous area installations	45
5.3.1	Intrinsically safe wiring	45
5.3.2	Non-sparking wiring	47
5.3.3	Non-incendive wiring (US/Canada only)	47
5.3.4	Flameproof wiring.....	48
5.3.5	Increased safety wiring	49
5.3.6	Explosion-proof wiring (US/Canada only)	49
5.4	Instructions specific to hazardous area installations.....	50
5.4.1	(Reference European ATEX Directive 94/9/EC, Annex II, 1/0/6).....	50
6	Commissioning	53
6.1	Basic safety information	53
6.2	Operating via the handheld programmer	53
6.2.1	Power up	54
6.2.2	Handheld programmer functions.....	54
6.2.2.1	The LCD display.....	55
6.2.2.2	Handheld programmer (Part No. 7ML1930-1BK)	57
6.2.3	Programming.....	59
6.2.3.1	Quick Start Wizard via the handheld programmer	64
6.2.3.2	Auto False Echo Suppression.....	68
6.2.3.3	Requesting an Echo Profile.....	69
6.3	Application examples	70
6.3.1	Liquid resin in storage vessel, level measurement	71
6.3.2	Horizontal vessel with volume measurement.....	72
6.3.3	Application with stillpipe	74
7	Remote operation	77
7.1	Operating via SIMATIC PDM	77
7.1.1	Functions in SIMATIC PDM	77
7.1.1.1	PDM function overview	77
7.1.1.2	Features of SIMATIC PDM Rev. 6.0, SP4 or higher.....	78

7.1.1.3	Features of SIMATIC PDM Rev. 5.2, SP1	78
7.1.1.4	SIMATIC PDM Version	78
7.1.2	Initial setup	78
7.1.2.1	Deactivating buffers	79
7.1.3	Updating the Electronic Device Description (EDD)	80
7.1.3.1	Configuring a new device	80
7.1.4	Quick Start Wizard via SIMATIC PDM	81
7.1.5	Changing parameter settings using SIMATIC PDM	86
7.1.6	Parameters accessed via pull-down menus	87
7.1.6.1	Echo profile utilities	88
7.1.6.2	Echo profile	89
7.1.6.3	View saved echo profiles	90
7.1.6.4	TVT Shaper	91
7.1.6.5	Auto false echo suppression	92
7.1.6.6	Echo setup	95
7.1.6.7	Maintenance	95
7.1.6.8	Select analog output	97
7.1.6.9	Self test	97
7.1.6.10	Loop test	97
7.1.6.11	Configuration flag reset	97
7.1.6.12	Master reset	98
7.1.6.13	Wear	98
7.1.6.14	HART Communication	98
7.1.6.15	Process variables	99
7.1.6.16	Trend	100
7.1.6.17	Device status	101
7.1.6.18	Update	101
7.1.6.19	Security	102
7.2	Operating via AMS Device Manager	103
7.2.1	Functions in AMS Device Manager	103
7.2.1.1	AMS function overview	103
7.2.1.2	Features of AMS Device Manager	104
7.2.1.3	Electronic Device Description (EDD)	104
7.2.1.4	Configuring a new device	104
7.2.1.5	Startup	105
7.2.1.6	Pull-down menu access	106
7.2.1.7	Device configuration	107
7.2.1.8	Quick Start Wizard via AMS Device Manager	107
7.2.2	Maintenance and diagnostics	116
7.2.3	Communication	117
7.2.4	Security	118
7.2.5	Device Diagnostics	119
7.2.5.1	Process variables	120
7.2.5.2	Password protection	121
7.2.5.3	User Manager utility	121
7.2.6	AMS menu structure	122
7.3	Operating via FDT (Field Device Tool)	126

7.3.1	Device Type Manager (DTM).....	126
7.3.2	SITRANS DTM.....	126
7.3.3	The device EDD.....	126
7.3.4	Configuring a new device via FDT.....	126
8	Parameter reference.....	127
8.1	Alphabetical parameter list.....	179
9	Service and maintenance.....	183
9.1	Basic safety information.....	183
9.2	Cleaning.....	183
9.3	Maintenance and repair work.....	184
9.3.1	Unit repair and excluded liability.....	185
9.3.2	Part replacement.....	185
9.4	Disposal.....	187
10	Diagnosing and troubleshooting.....	189
10.1	Communication troubleshooting.....	189
10.2	Device status icons.....	190
10.3	General fault codes.....	192
10.4	Operation troubleshooting.....	196
11	Technical data.....	199
11.1	Power.....	199
11.2	Performance.....	199
11.3	Interface.....	201
11.4	Mechanical.....	202
11.5	Environmental.....	205
11.6	Process.....	205
11.7	Approvals.....	206
11.8	Programmer (infrared keypad).....	208
12	Dimension drawings.....	209
12.1	Threaded horn antenna.....	209
12.2	Threaded horn antenna with extension.....	212
12.3	Flanged horn antenna.....	214
12.4	Flanged horn antenna with extension.....	216
12.5	Flanged encapsulated antenna (2"/DN50/50A sizes only).....	218
12.6	Flanged encapsulated antenna (3"/DN80/80A sizes and larger).....	220

12.7	Hygienic encapsulated antenna (2" ISO 2852 sanitary clamp)	222
12.8	Hygienic encapsulated antenna (3" ISO 2852 sanitary clamp)	223
12.9	Hygienic encapsulated antenna (4" ISO 2852 sanitary clamp)	224
12.10	Hygienic encapsulated antenna (DN 50 nozzle/slotted nut to DIN 11851)	225
12.11	Hygienic encapsulated antenna (DN 80 nozzle/slotted nut to DIN 11851)	226
12.12	Hygienic encapsulated antenna (DN 100 nozzle/slotted nut to DIN 11851)	227
12.13	Hygienic encapsulated antenna (DN 50 aseptic clamp to DIN 11864-1)	228
12.14	Hygienic encapsulated antenna (DN 80 aseptic clamp to DIN 11864-1)	229
12.15	Hygienic encapsulated antenna (DN 100 aseptic clamp to DIN 11864-1)	230
12.16	Hygienic encapsulated antenna (DN 50 aseptic flange to DIN 11864-2)	231
12.17	Hygienic encapsulated antenna (DN 80 aseptic flange to DIN 11864-2)	232
12.18	Hygienic encapsulated antenna (DN 100 aseptic flange to DIN 11864-2)	233
12.19	Hygienic encapsulated antenna (DN 50 aseptic clamp to DIN 11864-3)	234
12.20	Hygienic encapsulated antenna (DN 80 aseptic clamp to DIN 11864-3)	235
12.21	Hygienic encapsulated antenna (DN 100 aseptic clamp to DIN 11864-3)	236
12.22	Hygienic encapsulated antenna (Tuchenhagen Type N)	237
12.23	Hygienic encapsulated antenna (Tuchenhagen Type F)	238
12.24	Threaded PVDF antenna	239
12.25	Threaded connection markings	240
12.26	Raised-Face flange per EN 1092-1 for flanged horn antenna	241
12.27	Raised-Face flange per EN 1092-1 for flanged encapsulated antenna	243
12.28	Flat-Face flange	246
12.29	Aseptic/hygienic flange DN50, DN80, DN100 for DIN 11864-2	249
12.30	Process connection tag (pressure rated versions)	252
A	Appendix A: Technical reference	253
A.1	Principles of operation	253
A.2	Echo Processing	254
A.2.1	Process Intelligence	254
A.2.2	Echo Selection	255
A.2.3	CLEF Range	258
A.2.4	Echo Threshold	258
A.2.5	Echo Lock	258
A.2.6	Auto False Echo Suppression	259
A.2.7	Measurement Range	261
A.2.8	Measurement Response	261

A.2.9	Damping	262
A.3	Analog Output	262
A.3.1	Sensor Mode	263
A.3.2	Current Output Function.....	264
A.3.3	Loss of Echo (LOE)	264
A.3.4	Fail-safe Mode	265
A.4	Maximum Process Temperature Chart	265
A.5	Process Pressure/Temperature derating curves	267
A.5.1	Pressure Equipment Directive, PED, 97/23/EC	268
A.5.2	Horn antenna	269
A.5.3	Flanged horn antenna	270
A.5.4	Flanged encapsulated antenna.....	275
A.5.5	PVDF antenna.....	277
A.5.6	Hygienic encapsulated antenna	278
A.6	Loop power	281
A.6.1	Allowable operating area of SITRANS LR250	281
A.6.2	Curve 1 (General Purpose, Intrinsically Safe, Non-Sparking, Non-incendive)	282
A.6.3	Curve 2 (Flameproof, Increased Safety, Explosion-proof).....	283
A.7	Startup behavior	283
B	Appendix B: HART communications.....	285
B.1	SIMATIC PDM.....	285
B.2	HART Electronic Device Description (EDD)	285
B.3	HART Handheld 375/475	285
B.4	HART Communicator 375 menu structure.....	286
B.5	HART version.....	288
B.5.1	Burst Mode	288
B.5.2	HART Multidrop Mode.....	288
C	Appendix C: Certificates and support	289
C.1	Certificates	289
C.2	Technical support.....	289
13	List of abbreviations	291
14	LCD menu structure.....	293
14.1	LCD menu structure	293
	Glossary	297
	Index	303

Introduction

1.1 LR250 mA/HART manual usage

Note

This manual applies to the SITRANS LR250 mA/HART version only. HART® is a registered trademark of the HART Communication Foundation.

Follow these operating instructions for quick, trouble-free installation, and maximum accuracy and reliability of your device.

We always welcome suggestions and comments about manual content, design, and accessibility. Please direct your comments to:

Technical publications (<mailto:techpubs.smpi@siemens.com>)

1.2 Purpose of this documentation

These instructions contain all information required to commission and use the device. It is your responsibility to read the instructions carefully prior to installation and commissioning. In order to use the device correctly, first review its principle of operation.

The instructions are aimed at persons mechanically installing the device, connecting it electronically, configuring the parameters and commissioning it, as well as service and maintenance engineers.

1.3 Document history

The following table notes major changes in the documentation compared to the previous edition.

Edition	Remark
January 2014	<ul style="list-style-type: none">• Flanged encapsulated antenna version added.
August 2014	<ul style="list-style-type: none">• Hygienic encapsulated antenna version added.

1.4 Firmware revision history

This history establishes the correlation between the current documentation and the valid firmware of the device.

The documentation of this edition is applicable for the following firmware:

Firmware rev.	PDM EDD rev.	Date	Changes
1.00.03	1.00.03	25 Feb 2007	<ul style="list-style-type: none"> Initial release
1.01.00	1.01.00	27 Jul 2007	<ul style="list-style-type: none"> EDD ^{a)}/SIMATIC PDM: View > Display > Distance ^{b)} correctly reported EDD/SIMATIC PDM: Improved rendering of the echo profile and TVT
1.01.01	1.01.01	10 Jun 2008	<ul style="list-style-type: none"> Maintenance release of firmware and EDD ^{a)}
1.01.01	1.01.03	17 Jun 2008	<ul style="list-style-type: none"> The internal EDD revision has been incremented
1.02.01	1.02.01	2 Apr 2009	<ul style="list-style-type: none"> AMS EDD Rev. 1.02.01 Support NAMUR NE 43 Harmonization of menu structures and parameter names across products Display indicates progress towards first measurement
1.02.03	1.02.01	16 June 2010	<ul style="list-style-type: none"> Display contrast improvement Antenna type parameter cannot be modified
1.03.02 (requires HW 2.0.0)	1.02.01	16 June 2010	<ul style="list-style-type: none"> Low current HW 2.0.0 supported
1.03.03 (requires HW 2.0.0)	1.02.01	19 May 2011	<ul style="list-style-type: none"> Threaded PVDF antenna supported
1.03.04	1.02.03	31 Oct 2012	<ul style="list-style-type: none"> LUI updated version (new startup, progress bars, quick start updated to latest version, echo profile pan/zoom on display) antenna parameter removed, default near range set at factory

^{a)} Electronic Device Description

^{b)} See **Sensor Mode (2.2.2.)** for an illustration of **Distance**.

1.5 Designated use

Use the device to measure process media in accordance with the information in the operating instructions.

Note

Use in a domestic environment

This is a Class A Group 1 equipment intended for use in industrial areas.

In a domestic environment this device may cause radio interference.

1.6 Checking the consignment

1. Check the packaging and the device for visible damage caused by inappropriate handling during shipping.
2. Report any claims for damages immediately to the shipping company.
3. Retain damaged parts for clarification.
4. Check the scope of delivery by comparing your order to the shipping documents for correctness and completeness.

 WARNING
Using a damaged or incomplete device
Danger of explosion in hazardous areas.
<ul style="list-style-type: none">• Do not use damaged or incomplete devices.

1.7 Transportation and storage

To guarantee sufficient protection during transport and storage, observe the following:

- Keep the original packaging for subsequent transportation.
- Devices/replacement parts should be returned in their original packaging.
- If the original packaging is no longer available, ensure that all shipments are properly packaged to provide sufficient protection during transport. Siemens cannot assume liability for any costs associated with transportation damages.

 CAUTION
Insufficient protection during storage The packaging only provides limited protection against moisture and infiltration. <ul style="list-style-type: none">• Provide additional packaging as necessary.

1.8 Notes on warranty

The contents of this manual shall not become part of or modify any prior or existing agreement, commitment or legal relationship. The sales contract contains all obligations on the part of Siemens as well as the complete and solely applicable warranty conditions. Any statements regarding device versions described in the manual do not create new warranties or modify the existing warranty.

The content reflects the technical status at the time of publishing. Siemens reserves the right to make technical changes in the course of further development.



Safety information

2.1 Preconditions for safe use

This device left the factory in good working condition. In order to maintain this status and to ensure safe operation of the device, observe these instructions and all the specifications relevant to safety.

Observe the information and symbols on the device. Do not remove any information or symbols from the device. Always keep the information and symbols in a completely legible state.

2.1.1 Safety marking symbols

In manual	On product	Description
	 (Label on product: yellow background.)	WARNING: refer to accompanying documents (manual) for details.

2.1.2 Laws and directives

Observe the test certification, provisions and laws applicable in your country during connection, assembly and operation.

2.1.3 FCC Conformity

US Installations only: Federal Communications Commission (FCC) rules

 WARNING
Improper device modifications Danger to personnel, system and environment can result from improper modifications to the device. <ul style="list-style-type: none">• Changes or modifications not expressly approved by Siemens could void the user's authority to operate the equipment.

Note

- This equipment has been tested and found to comply with the limits for a Class A digital device, pursuant to Part 15 of the FCC Rules. These limits are designed to provide reasonable protection against harmful interference when the equipment is operated in a commercial environment.
 - This equipment generates, uses, and can radiate radio frequency energy and, if not installed and used in accordance with the operating instructions, may cause harmful interference to radio communications. Operation of this equipment in a residential area is likely to cause harmful interference to radio communications, in which case the user will be required to correct the interference at his own expense.
-

2.1.4 Conformity with European directives

The CE marking on the device symbolizes the conformity with the following European directives:

Electromagnetic compatibility EMC 2004/108/EC	Directive of the European Parliament and of the Council on the approximation of the laws of the Member States relating to electromagnetic compatibility and repealing Directive 89/336/EEC.
Low voltage directive LVD 2006/95/EC	Directive of the European Parliament and of the Council on the harmonisation of the laws of Member States relating to electrical equipment designed for use within certain voltage limits.
Atmosphère explosible ATEX 94/9/EC	Directive of the European Parliament and the Council on the approximation of the laws of the Member States concerning equipment and protective systems intended for use in potentially explosive atmospheres.
Radio and telecommunications terminal equipment R&TTE 1999/5/EC	Directive of the European Parliament and of the Council on radio equipment and telecommunications terminal equipment and the mutual recognition of their conformity.

The applicable directives can be found in the EC conformity declaration of the specific device.

2.1.5 CE Electromagnetic Compatibility (EMC) Conformity

This equipment has been tested and found to comply with the following EMC Standards:

EMC Standard	Title
CISPR 11:2009 + A1:2010/EN 55011:2009 + A1:2010, CLASS A	Limits and methods of measurements of radio disturbance characteristics of industrial, scientific, and medical (ISM) radio-frequency equipment.
EN 61326:2013 (IEC 61326:2012)	Electrical Equipment for Measurement, Control and Laboratory Use – Electromagnetic Compatibility.
EN61000-4-2:2009	Electromagnetic Compatibility (EMC) Part 4-2: Testing and measurement techniques – Electrostatic discharge immunity test.
EN61000-4-3:2006 + A1:2008 + A2:2010	Electromagnetic Compatibility (EMC) Part 4-3: Testing and measurement techniques – Radiated, radio-frequency, electromagnetic field immunity test 2006 + A1:2008 + A2:2010.
EN61000-4-4:2004 + A1:2010	Electromagnetic Compatibility (EMC) Part 4-4: Testing and measurement techniques – Electrical fast transient/burst immunity test.
EN61000-4-5:2006	Electromagnetic Compatibility (EMC) Part 4-5: Testing and measurement techniques – Surge immunity test.
EN61000-4-6:2010	Electromagnetic Compatibility (EMC) Part 4-6: Testing and measurement techniques – Immunity to conducted disturbances, induced by radio-frequency fields.
EN61000-4-8:2010	Electromagnetic Compatibility (EMC) Part 4-8: Testing and measurement techniques – Power frequency magnetic field immunity test.

2.2 Improper device modifications

 WARNING
<p>Improper device modifications</p> <p>Danger to personnel, system and environment can result from modifications to the device, particularly in hazardous areas.</p> <ul style="list-style-type: none"> • Only carry out modifications that are described in the instructions for the device. Failure to observe this requirement cancels the manufacturer's warranty and the product approvals.

2.3 Requirements for special applications

Due to the large number of possible applications, each detail of the described device versions for each possible scenario during commissioning, operation, maintenance or operation in systems cannot be considered in the instructions. If you need additional information not covered by these instructions, contact your local Siemens office or company representative.

Note

Operation under special ambient conditions

We highly recommend that you contact your Siemens representative or our application department before you operate the device under special ambient conditions as can be encountered in nuclear power plants or when the device is used for research and development purposes.

2.4 Use in hazardous areas

Qualified personnel for hazardous area applications

Persons who install, connect, commission, operate, and service the device in a hazardous area must have the following specific qualifications:

- They are authorized, trained or instructed in operating and maintaining devices and systems according to the safety regulations for electrical circuits, high pressures, aggressive, and hazardous media.
- They are authorized, trained, or instructed in carrying out work on electrical circuits for hazardous systems.
- They are trained or instructed in maintenance and use of appropriate safety equipment according to the pertinent safety regulations.

WARNING

Loss of safety of device with type of protection "Intrinsic safety Ex I"

If the device has already been operated in non-intrinsically safe circuits or the electrical specifications have not been observed, the safety of the device is no longer ensured for use in hazardous areas. There is a danger of explosion.

- Connect the device with type of protection "Intrinsic safety" solely to an intrinsically safe circuit.
- Observe the specifications for the electrical data on the certificate.

Description

3.1 SITRANS LR250 overview

⚠ WARNING**Loss of protection**

Danger to personnel, system and environment can result from improper use of the device.

- SITRANS LR250 is to be used only in the manner outlined in this manual, otherwise protection provided by the device may be impaired.

SITRANS LR250 is a 2-wire 25 GHz pulse radar level transmitter for continuous monitoring of liquids and slurries in storage vessels including high pressure and high temperature, to a range of 20 meters (66 feet). It is ideal for small vessels, material such as chemicals, food, beverages, solvents (including those of corrosive or aggressive nature), and low dielectric media.

The device consists of an electronic circuit coupled to an antenna and either a threaded or flange type process connection.

This device supports HART communication protocol. Signals are processed using Process Intelligence which has been field-proven in over 1,000,000 applications worldwide (ultrasonic and radar).

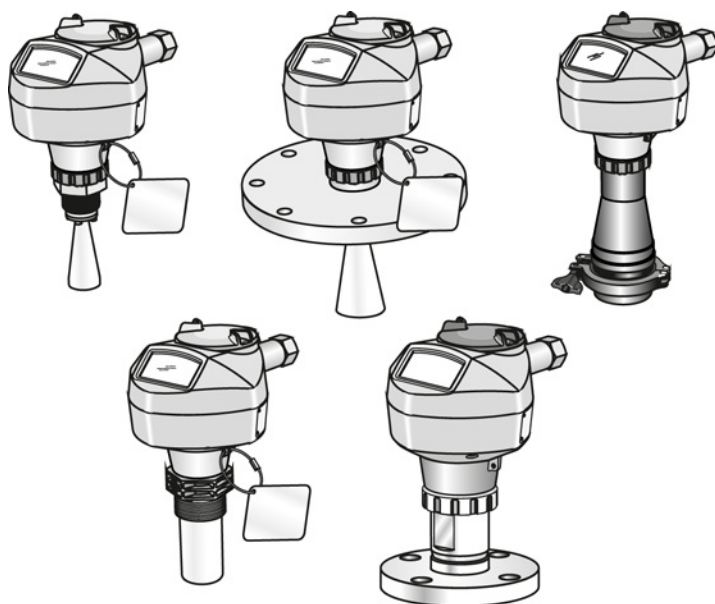

3.2 Programming

This device is very easy to install and configure via a graphical local user interface (LUI). You can modify the built in parameters either locally via the Siemens infrared handheld programmer, or from a remote location using one of the following options:

- SIMATIC PDM
- AMS Device Manager
- FDT/DTM platform (such as PACTware™ or FieldCare)
- HART Handheld 375/475

3.3 Applications

- liquids and slurries
- bulk storage vessels
- simple process vessels
- corrosive and aggressive
- hygienic/sanitary

3.4 Approvals and certificates

Note

For further details see Approvals (Page 206).

SITRANS LR250 is available with approvals for General purpose, sanitary or hygienic and for hazardous areas. In all cases, check the nameplate on your device, and confirm the approval rating.

Process Connections

A wide range of process connections and antenna options are available to suit virtually any vessel configuration.

Installing/mounting

4.1 Basic safety information

Note

Material compatibility

Siemens can provide you with support concerning selection of sensor components wetted by process media. However, you are responsible for the selection of components. Siemens accepts no liability for faults or failures resulting from incompatible materials.

WARNING

Unsuitable connecting parts

Danger of injury or poisoning.

In case of improper mounting hot, toxic and corrosive process media could be released at the connections.

- Ensure that connecting parts (such as flange gaskets and bolts) are suitable for connection and process media.

WARNING

Exceeded maximum ambient or process media temperature

Danger of explosion in hazardous areas.

Device damage.

- Make sure that the maximum permissible ambient and process media temperatures of the device are not exceeded.

WARNING

Open cable inlet or incorrect cable gland

Danger of explosion in hazardous areas.

- Close the cable inlets for the electrical connections. Only use cable glands or plugs which are approved for the relevant type of protection.

 WARNING
Incorrect conduit system Danger of explosion in hazardous areas as result of open cable inlet or incorrect conduit system. <ul style="list-style-type: none">• In the case of a conduit system, mount a spark barrier at a defined distance from the device input. Observe national regulations and the requirements stated in the relevant approvals.

4.1.1 Pressure applications

 DANGER
Pressure applications Danger to personnel, system and environment will result from improper disassembly. <ul style="list-style-type: none">• Never attempt to loosen, remove, or disassemble process connection while vessel contents are under pressure.

 WARNING
Pressure applications Danger to personnel, system and environment can result from improper installation. <ul style="list-style-type: none">• Improper installation may result in loss of process pressure.

 WARNING
Exceeded maximum permissible operating pressure Danger of injury or poisoning. The maximum permissible operating pressure depends on the device version. The device can be damaged if the operating pressure is exceeded. Hot, toxic and corrosive process media could be released. <ul style="list-style-type: none">• Make sure that the device is suitable for the maximum permissible operating pressure of your system.

Note

- The process connection tag shall remain with the process pressure boundary assembly. (The process pressure boundary assembly comprises the components that act as a barrier against pressure loss from the process vessel: that is, the combination of process connection body and emitter, but normally excluding the electrical enclosure). In the event the device package is replaced, the process connection tag shall be transferred to the replacement unit.
 - SITRANS LR250 units are hydrostatically tested, meeting or exceeding the requirement of the ASME Boiler and Pressure Vessel Code and the European Pressure Equipment Directive.
-

Note

- The serial numbers stamped in each process connection body, (flange, threaded, or sanitary), provide a unique identification number indicating date of manufacture. Example: MMDDYY – XXX (where MM = month, DD = day, YY = year, and XXX= sequential unit produced)
 - Further markings (space permitting) indicate flange configuration, size, pressure class, material, and material heat code.
-

4.1.1.1 Pressure Equipment Directive, PED, 97/23/EC

Siemens Level Transmitters with flanged, threaded, or sanitary clamp type process mounts have no pressure-bearing housing of their own and, therefore, do not come under the Pressure Equipment Directive as pressure or safety accessories (see EU Commission Guideline 1/8 and 1/20).

4.2 Installation location requirements

 WARNING
Aggressive atmospheres Danger to personnel, system and environment can result from unsuitable environment. <ul style="list-style-type: none">• Provide an environment suitable to the housing rating and materials of construction.

 CAUTION
Direct sunlight Device damage. The device can overheat or materials become brittle due to UV exposure. <ul style="list-style-type: none">• Protect the device from direct sunlight.• Make sure that the maximum permissible ambient temperature is not exceeded. Refer to the information in Chapter "Technical data (Page 199)".

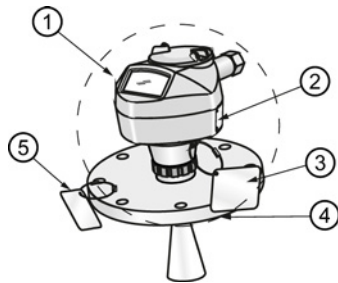

- ① Ambient temperature
- ② Device nameplate
- ③ Device tag
- ④ Process temperature (at process connection)
- ⑤ Process connection tag (contains process connection related information)

Antenna	①	③
Horn	-40 to +80 °C (-40 to +176 °F)	with FKM O-ring: -40 to +200 °C (-40 to 392 °F)
		with FFKM O-ring: -20 to +200 °C (-4 to +392 °F)
PVDF	-40 to +80 °C (-40 to +176 °F)	-40 to +80 °C (-40 to +176 °F)
Flanged encapsulated	-40 to +80 °C (-40 to +176 °F)	-40 to +170 °C (-40 to +338 °F)
Hygienic encapsulated	-40 to +80 °C (-40 to +176 °F)	-40 to +170 °C (-40 to +338 °F)
		with FKM seals used on process connection: -20 to +170 °C (-4 to +338 °F)
		with EPDM seals used on process connection: -40 to +120 °C (-40 to +248 °F)

Note

Details about the process connection, process temperature and materials are laser etched into the body of the flanged and hygienic versions. All other SITRANS LR250 versions have details listed on a tag.

4.3 Proper mounting

Note

- Correct location is key to a successful application.
 - Avoid reflective interference from vessel walls and obstructions by following guidelines in this chapter.
-

NOTICE
Incorrect mounting The device can be damaged, destroyed, or its functionality impaired through improper mounting. <ul style="list-style-type: none">• Before installing ensure there is no visible damage to the device.• Make sure that process connectors are clean, and suitable gaskets and glands are used.• Mount the device using suitable tools. Refer to the information in Installation instructions (Page 34) for installation torque requirements.

Note

- On devices with a removable head, there is no limit to the number of times a device can be rotated without damage.
 - When mounting, orient the front or back of the device towards the closest vessel wall or obstruction.
 - Do not rotate the enclosure after programming and vessel calibration, otherwise an error may occur, caused by a polarity shift of the transmit pulse.
-

4.3.1 Nozzle design

Threaded PVDF antenna

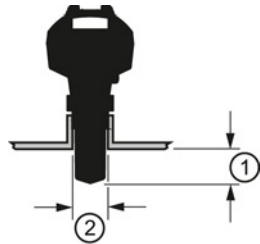

Stainless steel horn antenna

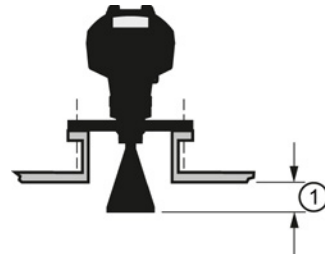

Flanged encapsulated antenna (FEA)

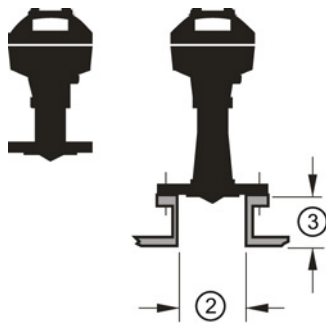

Hygienic encapsulated antenna (HEA)

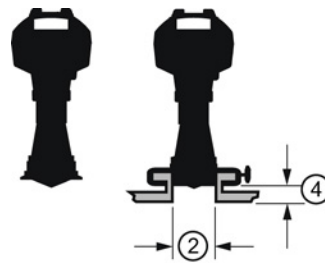

- ① Minimum clearance: 10 mm (0.4")
- ② Minimum diameter: 50 mm (2")
- ③ Maximum nozzle length
- ④ Maximum length/diameter ratio 1:1

- The end of the antenna must protrude a minimum of 10 mm (0.4") to avoid false echoes being reflected from the nozzle¹⁾.
- Minimum recommended nozzle diameter for the threaded PVDF antenna is 50 mm (2").
- An antenna extension (100 mm/3.93") is available for the horn antenna only.
- The maximum nozzle length for the FEA is 500 mm (19.68") when the nozzle diameter is DN150 (6"). Only shorter lengths are recommended for smaller diameters.
- When installing the SITRANS LR250 with hygienic process connection, it is good hygienic practice to install the antenna in a nozzle that has a maximum length/diameter ratio of 1:1. For example, 2" (DN50) diameter nozzle should be no longer than 2" (50 mm).
- When removing any sanitary/hygienic clamp version of the HEA to clean the lens, ensure it is re-installed in the exact position it was removed from, to avoid re-commissioning the device.

¹⁾ Not applicable for FEA or HEA

4.3.2 Nozzle location

- Avoid central locations on tall, narrow vessels
- Nozzle must be vertical and clear of imperfections

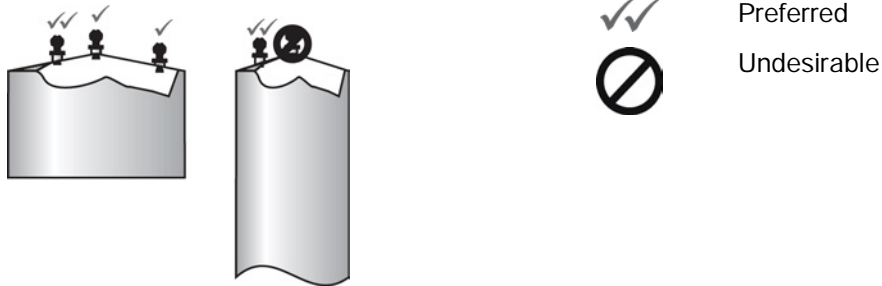

Beam angle

Note

- Beam width depends on antenna size and is approximate: see below.
 - For details on avoiding false echoes, see Auto False Echo Suppression (Page 259).
-
- Beam angle is the width of the cone where the energy density is half of the peak energy density.
 - The peak energy density is directly in front of and in line with the antenna.
 - There is a signal transmitted outside the beam angle, therefore false targets may be detected.

Horn antenna

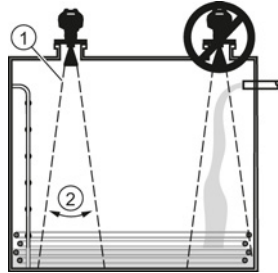

Flanged encapsulated antenna

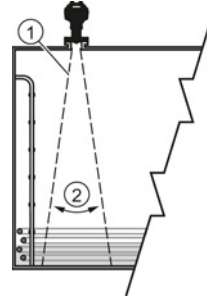

Threaded PVDF antenna

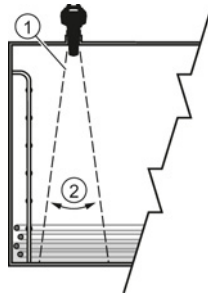

Hygienic encapsulated antenna

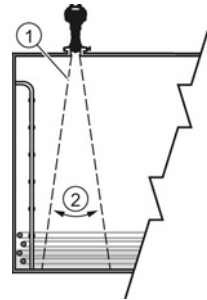

- ① Emission cone
- ② Beam angle

Emission cone type and beam angle

Antenna type	Antenna size		Beam angle
Horn	1.5"		19°
	2"		15°
	3"		10°
	4"		8°
Threaded PVDF			19°
	Process connection size	Process connection type	
Flanged encapsulated	2"	Class 150 ASME B16.5	12.8°
	3, 4, 6"	Class 150 ASME B16.5	9.6°
	50A	10K JIS B 2220	12.8°
	80A/100A/150A	10K JIS B 2220	9.6°
	DN50	PN10/16 EN1092-1	12.8°
	DN80/DN100/DN150	PN10/16 EN1092-1	9.6°
Hygienic encapsulated	2"	Sanitary Clamp according to ISO 2852	12.8°
	3, 4"		9.6°
	DN50	Aseptic/Hygienic nozzle/slotted nut according to DIN 11864-1 [Form A]	12.8°
	DN80/DN100		9.6°
	DN50	Aseptic/Hygienic flanged according to DIN 11864-2 [Form A]	12.8°
	DN80/DN100		9.6°
	DN50	Aseptic/Hygienic Clamp according to DIN 11864-3 [Form A]	12.8°
	DN80/DN100		9.6°
	DN50	Hygienic nozzle/slotted nut according to DIN 11851	12.8°
	DN80/DN100		9.6°
	Type F (50 mm) and Type N (68 mm)	Tuchenhagen Varivent	12.8°

Emission cone

- Keep emission cone free of interference from obstructions such as ladders, pipes, I-beams, or filling streams.

Access for programming

- Provide easy access for viewing the display and programming via the handheld programmer.

4.3.3 Orientation in a vessel with obstructions

Polarization reference point

For best results on a vessel with obstructions, or a stillpipe with openings, orient the front or back of the device toward the obstructions. For an illustration, see Device orientation (Page 33).

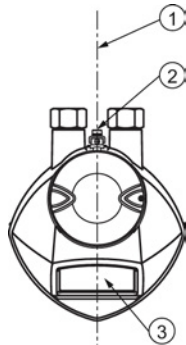

- ① Polarization axis
- ② Polarization reference point
- ③ Display

4.3.4 Mounting on a Stillpipe or Bypass Pipe

A stillpipe or bypass pipe is used for products with a low dK, or when vortex or extremely turbulent conditions exist. It can also be used to provide optimum signal conditions on foaming materials. See Dielectric constant of material measured in Performance (Page 199) for more information.

- The pipe diameter must be matched with the antenna size. Use the largest antenna size that will fit the stillpipe/bypass pipe¹⁾. See Threaded Horn dimensions, Raised-Face Flange per EN 1092-1 (Page 243), Flanged encapsulated dimensions (Page 218) or Hygienic encapsulated dimensions (Page 222).
- One continuous length of metallic pipe is preferred, without joints.
- Any false reflections created by joints/welds/imperfections will lead to inaccuracies of the measurement.
- Joints (if unavoidable) must be machined to ± 0.25 mm (± 0.010 ") and must have welded connecting sleeve on the outside.
- If using any hygienic process connections in conjunction with a stillpipe/bypass, please ensure that the antenna/lens are cleanable in accordance with the applicable approval.

¹⁾ Mounting in a pipe greater than 100 mm (4") can cause large errors, and therefore is not recommended.

Suitable pipe diameters:	Horn antenna	40 to 100 mm (1.5 to 4")
	PVDF antenna	50 mm (2") only
	Flanged encapsulated antenna	50 to 100 mm (2 to 4")
	Hygienic encapsulated antenna	50 to 100 mm (2 to 4")
Not recommended:	> 100 mm (4")	
Bypass vent:	Required at the upper end of the bypass ¹⁾	

¹⁾ To equalize pressure and keep the liquid level in the bypass constant with the liquid level in the vessel.

4.3.5 Device orientation

Bypass pipe installation

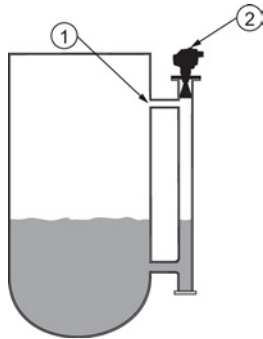

- ① Vent
- ② Align front or back of device with vents¹⁾

Stillpipe installation

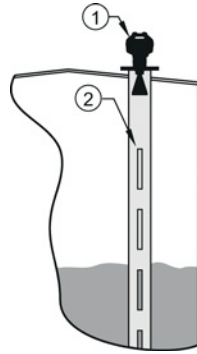

- ① Align front or back of device with stillpipe slots¹⁾
- ② Slots

¹⁾ Horn antenna version shown as example

4.4 Installation instructions

 WARNING
Pressure applications Danger to personnel, system and environment can result from improper installation. <ul style="list-style-type: none">• Improper installation may result in loss of process pressure.

 WARNING
Improper installation Danger to personnel, system and environment can result from improper installation. <ul style="list-style-type: none">• Installation shall only be performed by qualified personnel and in accordance with local governing regulations.

NOTICE
Device handling Damage to device may result from improper handling. <ul style="list-style-type: none">• Handle the device using the enclosure, not the process connection or tag, to avoid damage.• Take special care when handling the threaded PVDF and Hygienic or Flanged encapsulated antennas. Any damage to the antenna surface, particularly to the tip/lens, could affect performance. (For example, do not sit device on its lens antenna.)

Note

- For European Union and member countries, installation must be according to ETSI EN 302372.
 - Refer to the device nameplate for approval information.
-

Note

The outer part of the lens on the flanged encapsulated antenna version may not appear to lie flush before installation and this is normal. This will flatten after installation and will not impact the performance of the device.

4.4.1 Threaded versions

 WARNING
Pressure applications Danger of injury or poisoning. It may be necessary to use PTFE tape or other appropriate thread sealing compound, and to tighten the process connection beyond hand-tight. (The maximum recommended torque for Threaded versions is 40 N-m (30 ft.lbs.)

1. Before inserting the device into its mounting connection, check to ensure the threads are matching, to avoid damaging them.
2. Simply screw the device into the process connection, and hand tighten, or use a wrench.

4.4.2 Flanged versions

NOTICE
Improper materials The user is responsible for the selection of bolting and gasket materials (except for Flanged encapsulated antenna) which will fall within the limits of the process connection and its intended use, and which are suitable for the service conditions.

Special Instructions for Flanged encapsulated antenna only

Note

- Use spring washers
 - Lens assembly acts as integral gasket, no other required
 - Use recommended torque values for tightening bolts
-

Flange bolting: recommended torque

Pressure class	Nominal pipe size (NPS)	Number of bolts	Recommended torque (Nm)
ASME B16.5, Class 150	2"	4	30 – 50
	3"		50 – 70
	4"	8	40 – 60
	6"		70 – 90
EN1092-1, PN16 / JIS B 2220, 10K	DN50/50A	4	30 – 50
	DN80/80A	8	
	DN100/100A		
	DN150/150A		60 – 80

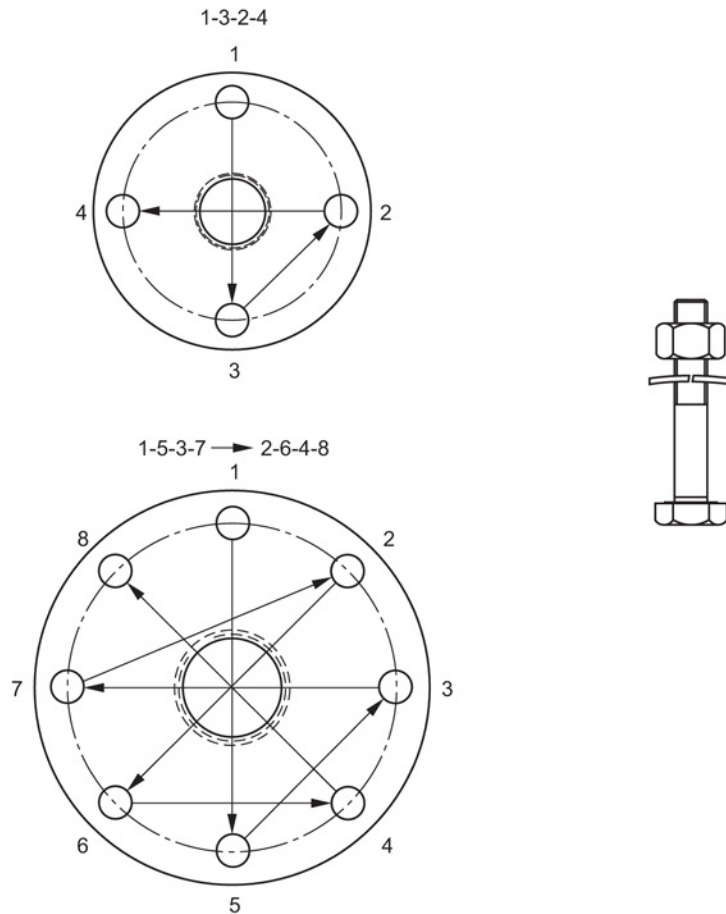

Flange bolting instructions:

1. Use cross-pattern sequence as shown.
2. Check uniformity of the flange gap.
3. Apply adjustments by selective tightening if required.
4. Torque incrementally until desired value is reached.
5. Check/re-torque after 4 to 6 hours.

Recommendations for flange bolting:

- Check bolts periodically, re-torque as required.
- Use new lens, O-ring and spring washers after removal from installation.
For instructions on replacing the lens, see Part replacement (Page 185).

See Flanged Horn with extension (Page 214), Raised-Face Flange per EN 1092-1 (Page 243), Flat-Face Flange (Page 246), and Flanged encapsulated antenna (3"/DN80/80A sizes and larger) (Page 220) for dimensions.

4.4.3 Hygienic versions

⚠ WARNING
Loss of sanitary approvals
Loss of sanitary approvals can result from improper installation/mounting.
<ul style="list-style-type: none">• Take special care when installing in hygienic or sanitary applications. Comply with installation/mounting guidelines to ensure cleanliness and the ability to keep the wetted parts in a position to be readily cleanable. (See relevant EHEDG/3A documentation - not supplied).

NOTICE
Loss of sanitary approvals
<ul style="list-style-type: none">• For 3-A Sanitary Approved device installation where the customer tank process connection exists, a leak detection port of minimum 2.4 mm diameter must be provided at the lowest point in the process connection where leakage can occur.• If leakage is detected at any time while the device is installed, then the device process connection parts must be disassembled and thoroughly cleaned prior to gasket replacement and reassembly.

Note

- For Hygienic encapsulated antenna, the lens acts as a gasket/seal and should be used in conjunction with a cleanable seal as required by the specific process connections (for example, DIN 11864-3).

Hygienic encapsulated antenna leak detection port

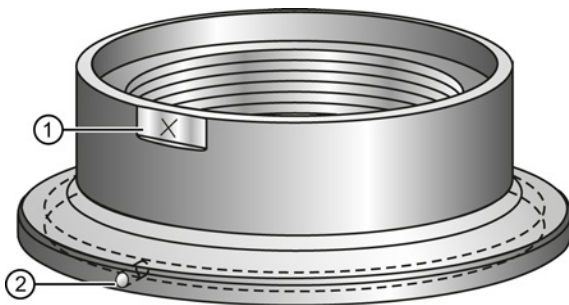

- ① Orientation mark for leak detection port
- ② Leak detection port

4.5 Disassembly

DANGER

Pressure applications

Danger to personnel, system and environment will result from improper disassembly.

- Never attempt to loosen, remove, or disassemble process connection while vessel contents are under pressure.

WARNING

Incorrect disassembly

The following dangers may result through incorrect disassembly:

- Injury through electric shock
- Danger through emerging media when connected to the process
- Danger of explosion in hazardous area

In order to disassemble correctly, observe the following:

- Before starting work, make sure that you have switched off all physical variables such as pressure, temperature, electricity etc. or that they have a harmless value.
- If the device contains dangerous media, it must be emptied prior to disassembly. Make sure that no environmentally hazardous media are released.
- Secure the remaining connections so that no damage can result if the process is started unintentionally.

Connecting

5.1 Basic safety information

NOTICE
Condensation in the device Damage to device through formation of condensation if the temperature difference between transportation or storage and the mounting location exceeds 20 °C (68°F). <ul style="list-style-type: none">• Before taking the device into operation let the device adapt for several hours in the new environment.

 WARNING
Missing PE/ground connection Danger of electric shock. Depending on the device version, connect the power supply as follows: <ul style="list-style-type: none">• Power plug: Ensure that the used socket has a PE/ground conductor connection. Check that the PE/ground conductor connection of the socket and power plug match each other.• Connecting terminals: Connect the terminals according to the terminal connection diagram. First connect the PE/ground conductor.

5.2 Connecting SITRANS LR250

 WARNING
Incorrect connection to power source Danger to personnel, system and environment can result from improper power connection. <ul style="list-style-type: none">• The DC input terminals shall be supplied from a source providing electrical isolation between the input and output, in order to meet the applicable safety requirements of IEC 61010-1.• All field wiring must have insulation suitable for rated voltages.

 **WARNING**

Loss of protection

Loss of approvals can result from improper installation.

- Check the nameplate on your device, to verify the approval rating.
- Use appropriate conduit seals to maintain IP or NEMA rating.
- See Wiring setups for hazardous area installations (Page 45).

NOTICE

Improper cables and conduit

- Separate cables and conduits may be required to conform to standard instrumentation wiring practices or electrical codes.

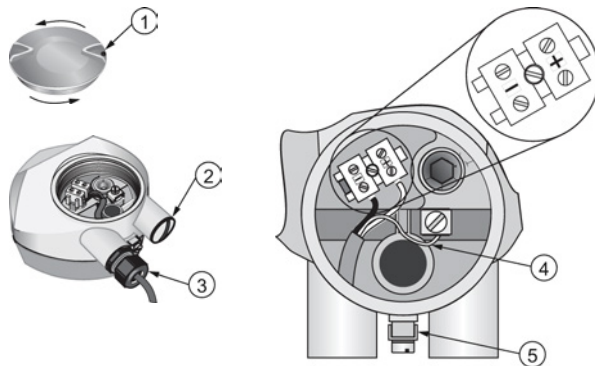

- ① Use a 2 mm Allen key to loosen the lid-lock set screw ^{c)} ④ Cable shield
② Plug (IP68) ⑤ Ground terminal
③ Optional cable gland ^{a) b)} (or NPT cable entry)^{b)}

^{a)} May be shipped with the device.

^{b)} If cable is routed through conduit, use only approved suitable-size hubs for waterproof applications.

^{c)} Not applicable to 3-A Sanitary approved device.

Wiring instructions

1. Strip the cable jacket for approximately 70 mm (2.75") from the end of the cable, and thread the wires through the gland. (If cable is routed through conduit, use only approved suitable-size hubs for waterproof applications.)
2. Connect the wires to the terminals as shown: the polarity is identified on the terminal block.
3. Ground the device according to local regulations.
4. Tighten the gland to form a good seal.
5. Close the lid and secure the locking screw before programming and device configuration.

Note

Lid-lock set screw not applicable to 3-A Sanitary approved device.

Connecting HART

Typical PLC/mA configuration with HART

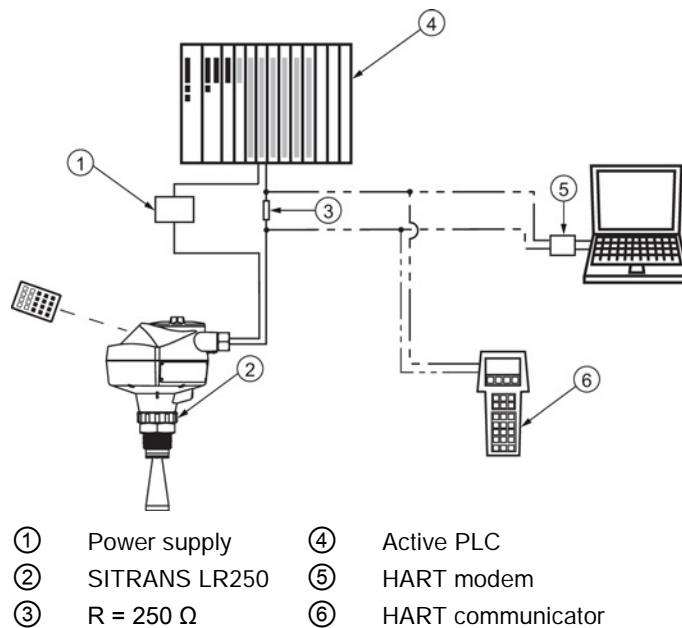

Note

- Depending on the system design, the power supply may be separate from the PLC, or integral to it.
- HART resistance (total loop resistance, that is, cable resistance plus 250 Ohm [resistor]) must be limited according to the allowable operating area as shown in either Curve 1 (Page 282) (General Purpose, Intrinsically Safe, Non-Sparking, Non-incendive) or Curve 2 (Page 283) (Flameproof, Increased Safety, Explosion-proof).

5.3 Wiring setups for hazardous area installations

There are six wiring options for hazardous area installations:

- Intrinsically Safe wiring (Page 45)
- Non-Sparking wiring (Page 47)
- Non-incendive wiring (US/Canada only) (Page 47)
- Flameproof wiring (Page 48)
- Increased safety wiring (Page 49)
- Explosion-proof wiring (US/Canada only) (Page 49)

In all cases, check the nameplate on your instrument, confirm the approval rating, and perform installation and wiring according to your local safety codes.

5.3.1 Intrinsically safe wiring

Device nameplate (ATEX/IECEX/INMETRO/RCM)

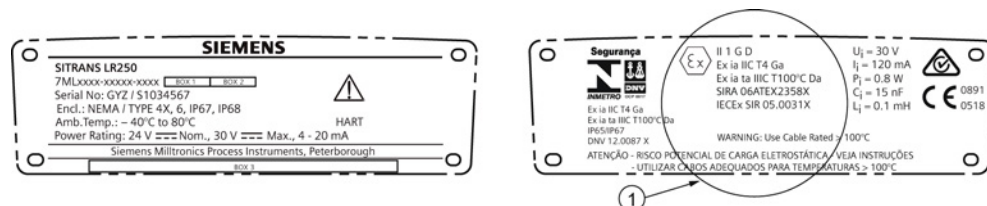

- ① ATEX certificate

The ATEX certificate listed on the nameplate can be downloaded from our website:

Product page (<http://www.siemens.com/LR250>)

Go to **Support > Approvals / Certificates**.

The IECEx certificate listed on the nameplate can be viewed on the IECEx website. Go to:

IECEx (<http://iecex.iec.ch/>)

Click on **Certified Equipment** then enter the certificate number IECEx SIR 05.0031X.

Device nameplate (FM/CSA)

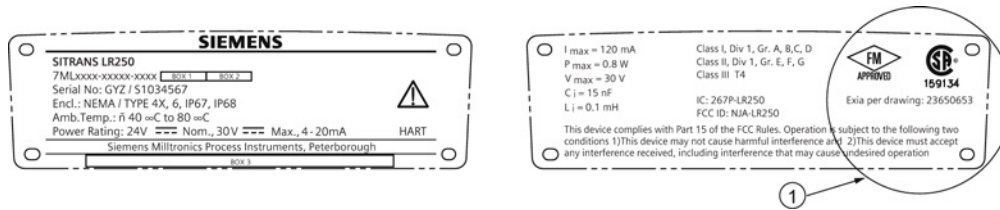

The connection drawing number listed on the nameplate can be downloaded from our website:

Product page (<http://www.siemens.com/LR250>)

Go to **Support > Installation Drawings > Level Measurement > SITRANS LR250.**

- For power demands see Curve 1 (General Purpose, Intrinsically Safe, Non-Sparking, Non-incendive) (Page 282).
- For wiring requirements: follow local regulations.
- Approved dust-tight and water-tight conduit seals are required for outdoor NEMA 4X / type 4X / NEMA 6, IP67, IP68 locations.
- Refer to Instructions specific to hazardous area installations (Page 50).

Note

Selecting a suitable PLC input module or power supply requires knowledge about Intrinsic Safety and the application. It is the responsibility of the installer to ensure that the intrinsically safe installation complies with both the apparatus approval requirements and the relevant national code of practice.

5.3.2 Non-sparking wiring

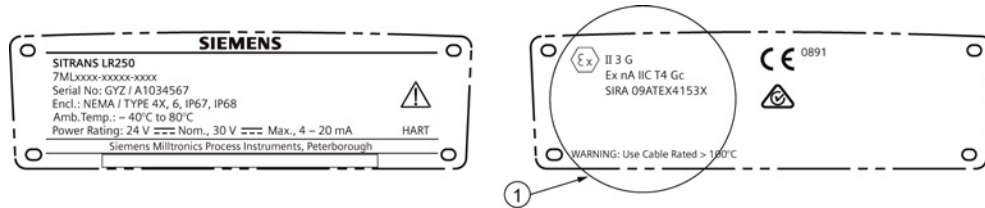

① ATEX certificate

The ATEX certificate listed on the nameplate can be downloaded from our website:

Product page (<http://www.siemens.com/LR250>)

Go to: **Support > Approvals / Certificates.**

- For power demands see Curve 1 (General Purpose, Intrinsically Safe, Non-Sparking/Energy Limited, Non-incendive) (Page 282).
- For wiring requirements follow local regulations.

5.3.3 Non-incendive wiring (US/Canada only)

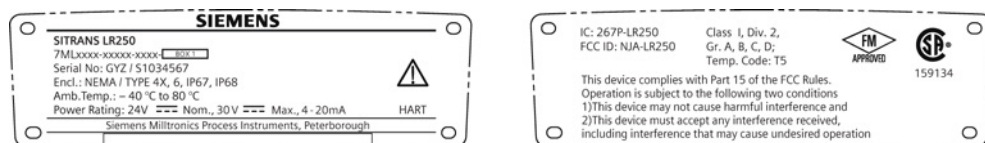

The FM/CSA Class 1, Div 2 connection drawing number 23650673 can be downloaded from our website:

Product page (<http://www.siemens.com/LR250>)

Go to **Support > Installation Drawings > Level Measurement > SITRANS LR250.**

- For power demands see Curve 1 (General Purpose, Intrinsically Safe, Non-Sparking, Non-incendive) (Page 282).

5.3.4 Flameproof wiring

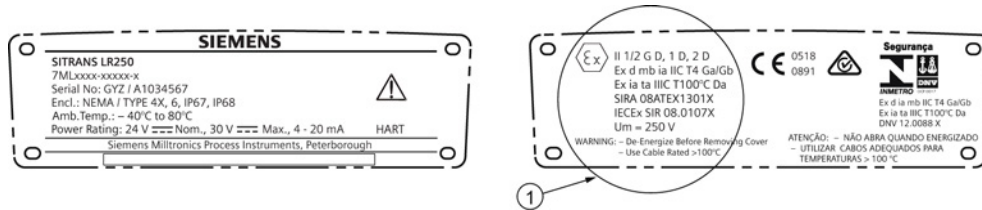

① ATEX certificate

The ATEX certificate listed on the nameplate can be downloaded from our website:

Product page (<http://www.siemens.com/LR250>)

Go to **Support > Approvals / Certificates**.

The IECEx certificate listed on the nameplate can be viewed on the IECEx website. Go to:

IECEx (<http://iecex.iec.ch/>)

Click on **Certified Equipment** then enter the certificate number IECEx SIR 08.0107X.

- For power demands see Curve 2 (Flameproof, Increased Safety, Explosion-proof) (Page 283).
- For wiring requirements follow local regulations.
- See also Instructions specific to hazardous area installations (Page 50) and the ATEX certificate listed above.

5.3.5 Increased safety wiring

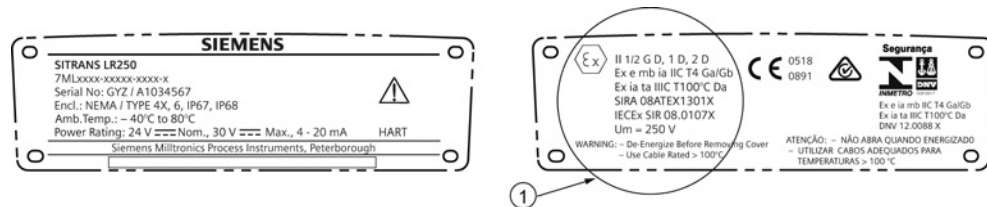

① ATEX certificate

The ATEX certificate listed on the nameplate can be downloaded from our website:

Product page (<http://www.siemens.com/LR250>)

Go to **Support > Approvals / Certificates**.

The IECEx certificate listed on the nameplate can be viewed on the IECEx website:

IECEx (<http://iecex.iec.ch/>)

Click on **Certified Equipment** then enter the certificate number IECEx SIR 08.0107X.

- For power demands see Curve 2 (Flameproof, Increased Safety, Explosion-proof) (Page 283).
- For wiring requirements follow local regulations.
- See also Instructions specific to hazardous area installations (Page 50) and the ATEX certificate listed above.

5.3.6 Explosion-proof wiring (US/Canada only)

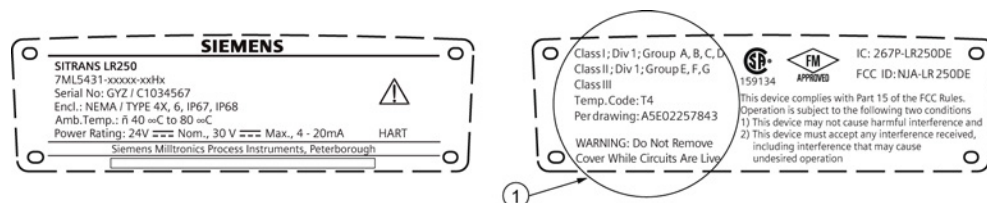

① FM/CSA Explosion Proof connection drawing

The connection drawing number listed on the nameplate can be downloaded from our website:

Product page (<http://www.siemens.com/LR250>)

Go to **Support > Installation Drawings > Level Measurement > SITRANS LR250**

- For power demands see Curve 2 (Flameproof, Increased Safety, Explosion-proof) (Page 283).

5.4 Instructions specific to hazardous area installations

5.4.1 (Reference European ATEX Directive 94/9/EC, Annex II, 1/0/6)

The following instructions apply to equipment covered by certificate number SIRA 06ATEX2358X, SIRA 08ATEX1301X, and SIRA 09ATEX4153X.

1. For use and assembly, refer to the main instructions.
2. The equipment is certified for use as Category 1GD equipment per SIRA 06ATEX2358X; Category 1/2 GD, 1D, 2D equipment per SIRA 08ATEX1301X; and Category 3G equipment per SIRA 09ATEX4153X.
3. The equipment may be used with flammable gases and vapors with apparatus group IIC, IIB and IIA and temperature classes T1, T2, T3 and T4.
4. The equipment has a degree of ingress protection of IP67 and a temperature class of T100 °C and may be used with flammable dusts.
5. The equipment is certified for use in an ambient temperature range of -40 °C to +80 °C.
6. The equipment has not been assessed as a safety related device (as referred to by Directive 94/9/EC Annex II, clause 1.5).
7. Installation and inspection of this equipment shall be carried out by suitably trained personnel in accordance with the applicable code of practice (EN 60079-14 and EN 60079-17 in Europe).
8. The equipment is non-repairable.
9. The certificate numbers have an 'X' suffix, which indicates that special conditions for safe use apply. Those installing or inspecting this equipment must have access to the certificates.
10. If the equipment is likely to come into contact with aggressive substances, then it is the responsibility of the user to take suitable precautions that prevent it from being adversely affected, thus ensuring that the type of protection is not compromised.
 - Aggressive substances: for example, acidic liquids or gases that may attack metals, or solvents that may affect polymeric materials.
 - Suitable precautions: for example, establishing from the material's data sheet that it is resistant to specific chemicals.

Special conditions for safe use (denoted by X after the certificate number)

- Parts of the enclosure may be non-conducting and may generate an ignition-capable level of electrostatic charge under certain extreme conditions. The user should ensure that the equipment is not installed in a location where it may be subjected to external conditions (such as high-pressure steam), which might cause a build-up of electrostatic charge on non-conducting surfaces.
- Aluminium, magnesium, titanium or zirconium may be used at the accessible surface of the equipment. In the event of rare incidents, ignition sources due to impact and friction sparks could occur. This shall be considered when the SITRANS LR250 mA/HART is being installed in locations that specifically require group II, level of protection Ga or Da.
- The equipment shall be bonded to the system earth in accordance with the relevant code of practice.
- When the SITRANS LR250 mA/HART is used in the presence of combustible dust, the gland that is fitted to the equipment shall also be suitable for use in the presence of combustible dust, as certified by an ATEX notified body, in addition, the installation of the gland shall not compromise the IP6X rating of the equipment enclosure.

Commissioning

6.1 Basic safety information

 WARNING
Loss of explosion protection Danger of explosion when device is not properly commissioned If opening device <ul style="list-style-type: none">• Isolate from power. - or - <ul style="list-style-type: none">• Ensure that the atmosphere is explosion-free (hot work permit). Ensure device is properly closed before returning to operation.

6.2 Operating via the handheld programmer

The handheld programmer used with this device contains lithium batteries that are non-replaceable.

Lithium batteries are primary power sources with high energy content designed to represent the highest possible degree of safety.

 WARNING
Potential hazard Lithium batteries may present a potential hazard if they are abused electrically or mechanically. <ul style="list-style-type: none">• Observe the following precautions when handling and using lithium batteries:<ul style="list-style-type: none">– Do not short-circuit, recharge or connect with false polarity.– Do not expose to temperature beyond the specified temperature range or incinerate the battery.– Do not crush, puncture or open cells or disassemble battery packs.– Do not weld or solder to the battery's body.– Do not expose contents to water.

6.2.1 Power up

Power up the device. A transition screen showing first the Siemens logo and then the current firmware revision is displayed while the first measurement is being processed. The first time the device is configured, you will be prompted to select a language (English, German, French, or Spanish). To change the language again, see **Language (7.)**.

Press **Mode**  to toggle between Measurement and Program mode.

6.2.2 Handheld programmer functions

The radar device carries out its level measurement tasks according to settings made via parameters. The settings can be modified locally via the Local User Interface (LUI) which consists of an LCD display and a handheld programmer.

A Quick Start Wizard provides an easy step-by-step procedure to configure the device for a simple application. Access the wizards:

- locally [see Quick Start Wizard via the handheld programmer (Page 64)]
- or from a remote location [see Quick Start Wizard via SIMATIC PDM (Page 81), or Quick Start Wizard via AMS Device Manager (Page 107)]

For more complex setups see Application Examples (Page 70), and for the complete range of parameters see Parameter Reference (Page 127).

6.2.2.1 The LCD display

Measurement mode display

Normal operation

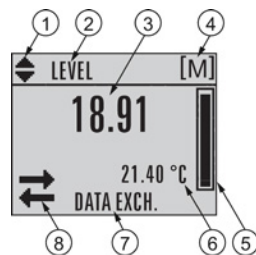

- ① Toggle indicator ^{a)} for linear units or %
- ② Selected operation: level, space, distance, or volume
- ③ Measured value (level, space, distance, or volume)
- ④ Units
- ⑤ Bar graph indicates level
- ⑥ Secondary region indicates on request ^{b)} electronics temperature, echo confidence, loop current, or distance
- ⑦ Text area displays status messages
- ⑧ Device status indicator, see Device status icons (Page 190)

^{a)} Press **UP** or **DOWN** arrow to switch.

^{b)} In response to a key press request. For details, see Handheld Programmer (Page 57) for key functions in Measurement mode.

Fault present

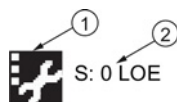

- ① Device status indicator, see Device status icons (Page 190)
- ② Text area displays status messages

PROGRAM mode display

Navigation view

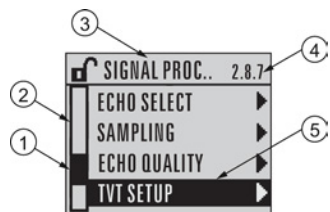

- | | | | |
|---|--------------|---|---------------------|
| ① | Item band | ④ | Current item number |
| ② | Menu bar | ⑤ | Current item |
| ③ | Current menu | | |

- A visible menu bar indicates the menu list is too long to display all items.
- A band halfway down the menu bar indicates the current item is halfway down the list.
- The depth and relative position of the item band on the menu bar indicates the length of the menu list, and approximate position of the current item in the list.
- A deeper band indicates fewer items.

Parameter view

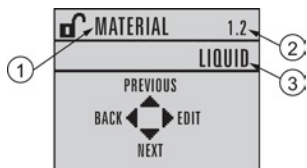

- | | |
|---|---------------------------|
| ① | Parameter name |
| ② | Parameter number |
| ③ | Parameter value/selection |

Edit view

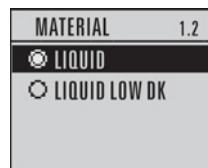









6.2.2.2 Handheld programmer (Part No. 7ML1930-1BK)

The programmer is ordered separately.



Key functions in measurement mode

Key	Function	Result
	Updates the loop current	New value is displayed in LCD secondary region.
	Updates internal enclosure temperature reading	
	Updates echo confidence value	New value is displayed in LCD secondary region.
	Updates distance measurement	
	Mode opens PROGRAM mode	Opens the menu level last displayed in this power cycle, unless power has been cycled since exiting PROGRAM mode or more than 10 minutes have elapsed since PROGRAM mode was used. Then top level menu will be displayed.
	RIGHT arrow opens PROGRAM mode	Opens the top level menu.
 	UP or DOWN arrow toggles between linear units and percent	LCD displays measured value in either linear units or percent.

6.2.3 Programming

Note

- While the device is in PROGRAM mode the output remains fixed and does not respond to changes in the device.
 - The device automatically returns to Measurement mode after a period of inactivity in PROGRAM mode (between 15 seconds and 10 minutes, depending on the menu level).
-

Change parameter settings and set operating conditions to suit your specific application. For remote operation see Operating via SIMATIC PDM (Page 77) or Operating via AMS Device Manager (Page 103).

Parameter menus

Note

For the complete list of parameters with instructions, see Parameter Reference (Page 127).

Parameters are identified by name and organized into function groups. See LCD menu structure (Page 293).

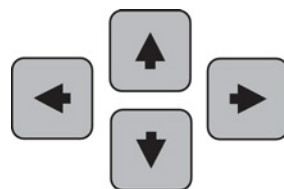
**1. QUICK START****2. SETUP**

2.1. DEVICE



.....

2.7. LINEARIZATION

2.7.1. VOLUME

2.7.1.1. VESSEL SHAPE

1. Enter PROGRAM mode

- Point the programmer at the display from a maximum distance of 300 mm (1 ft).
- **RIGHT arrow**  activates PROGRAM mode and opens menu level 1.
- **Mode**  opens the menu level last displayed in PROGRAM mode within the last 10 minutes, or menu level 1 if power has been cycled since then.

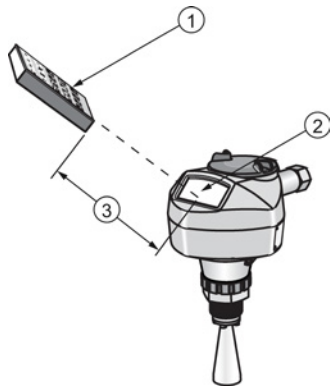







- ① Handheld programmer ② Display ③ Maximum distance: 300 mm (1 ft)



2. Navigating: key functions in Navigation mode

Note

- In Navigation mode **ARROW** keys move to the next menu item in the direction of the arrow.
 - For Quick Access to parameters via the handheld programmer, press Home  , then enter the menu number, for example: **2.7.1**. (Volume).
-

Key	Name	Menu level	Function
 	UP or DOWN arrow	menu or parameter	Scroll to previous or next menu or parameter
	RIGHT arrow	menu	Go to first parameter in the selected menu, or open next menu.
		parameter	Open Edit mode.
	LEFT arrow	menu or parameter	Open parent menu.
	Mode	menu or parameter	Change to MEASUREMENT mode.
	Home	menu or parameter	Open top level menu: menu 1.

3. Editing in PROGRAM mode

- Navigate to the desired parameter.
- Press **RIGHT arrow**  to open parameter view.
- Press **RIGHT arrow**  again to open **Edit** mode. The current selection is highlighted. Scroll to a new selection.
- Press **RIGHT arrow**  to accept it.

The LCD returns to parameter view and displays the new selection.

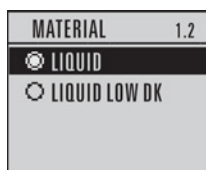
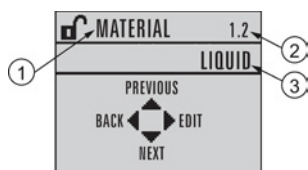



① Parameter name

② Parameter number

③ Current selection

4. Changing a numeric value

- Navigate to the desired parameter.
- Press **RIGHT arrow**  to open parameter view. The current value is displayed.
- Press **RIGHT arrow**  again to open **Edit** mode. The current value is highlighted.
- Key in a new value.
- Press **RIGHT arrow**  to accept it.

The LCD returns to parameter view and displays the new selection.

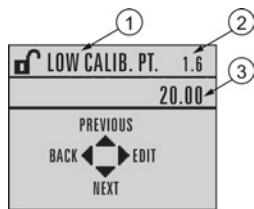









① Parameter name

② Parameter number

③ Current selection

Key functions in edit mode

Key	Name	Function	
 	UP or DOWN arrow	Selecting options	Scrolls to item.
		Numeric editing	<ul style="list-style-type: none"> • Increments or decrements digits • Toggles plus and minus sign
	RIGHT arrow	Selecting options	<ul style="list-style-type: none"> • Accepts the data (writes the parameter) • Changes from Edit to Navigation mode
		Numeric editing	<ul style="list-style-type: none"> • Moves cursor one space to the right • or, with cursor on Enter sign, accepts the data and changes from Edit to Navigation mode
	LEFT arrow:	Selecting options	Cancels Edit mode without changing the parameter.
		Numeric editing	<ul style="list-style-type: none"> • Moves cursor to plus/minus sign if this is the first key pressed • or moves cursor one space to the left
	Clear	Numeric editing	Erases the display.
	Decimal point	Numeric editing	Enters a decimal point.
	Plus or minus sign	Numeric editing	Changes the sign of the entered value.
 to 	Numeral	Numeric editing	Enters the corresponding character.





6.2.3.1 Quick Start Wizard via the handheld programmer

Note

- A reset to factory defaults should be performed before running the Quick Start Wizard if the device has been used in a previous application. See **Master Reset (4.1.)**.
 - The Quick Start wizard settings are inter-related and changes apply only after you select **Finish** in the Wizard Complete step.
 - Do not use the Quick Start wizard to modify parameters: see instead Parameter Reference (Page 127). (Perform customization for your application only after the Quick Start has been completed).
 - Default settings in the parameter tables are indicated with an asterisk (*).
-

1. Quick Start

1.1. Quick Start Wiz

- Point the programmer at the display from a maximum distance of 300 mm (1 ft), then press **RIGHT arrow**  to activate PROGRAM mode and open menu level 1.
- Press **RIGHT arrow**  twice to navigate to menu item 1.1 and open parameter view.
- Press **RIGHT arrow**  to open Edit mode or **DOWN arrow** to accept default values and move directly to the next item.
- To change a setting, scroll to the desired item or key in a new value.
- After modifying a value, press **RIGHT arrow**  to accept it and press **DOWN arrow**  to move to the next item.
- Quick Start settings take effect only after you select **Finish**.



Material

Selects the appropriate echo processing algorithms for the material [see **Position Detect (2.8.4.2.)** for more detail].

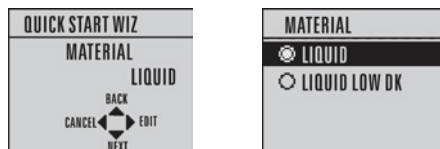

Options	*	LIQUID
		LIQUID LOW DK ^{a)} (low dielectric liquid – CLEF algorithm enabled)

a) $dK < 3.0$

Response Rate

Sets the reaction speed of the device to measurement changes in the target range. Use a setting just faster than the maximum filling or emptying rate (whichever is greater).

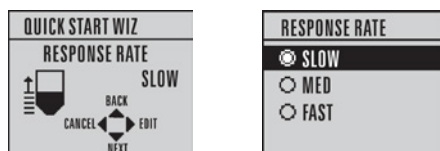

Options		Response Rate (1.3.)	Fill rate per Minute (2.4.2.)/Empty rate per Minute (2.4.3.)
	*	SLOW	0.1 m/min (0.32 ft/min)
		MED	1.0 m/min (3.28 ft/min)
		FAST	10.0 m/min (32.8 ft/min)

Units

Sensor measurement units.

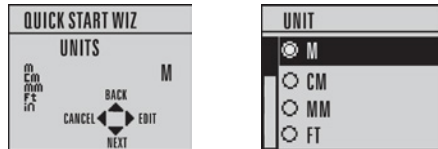

Options	m, cm, mm, ft, in. Default: m
----------------	----------------------------------

Operation

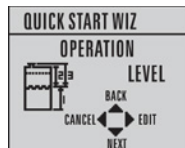

Operation		Description
NO SERVICE		Measurement and associated loop current are not updated, and the device defaults to Fail-safe mode ^{a)} .
LEVEL	*	Distance to material surface referenced from Low Calibration Point
SPACE		Distance to material surface referenced from High Calibration Point
DISTANCE		Distance to material surface referenced from Sensor reference point

^{a)} See **Material Level (2.5.1.)** for more detail.

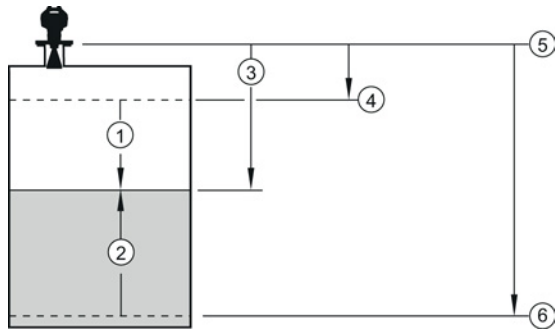

- ① Space
- ② Level
- ③ Distance
- ④ High Calibration Point (process full level)
- ⑤ Sensor reference point ^{a)}
- ⑥ Low Calibration Point (process empty level)

^{a)} The point from which High and Low Calibration points are referenced: see **Dimension drawings**.

Low Calibration Point

Distance from Sensor Reference to Low Calibration Point: usually process empty level. (See **Operation** for an illustration.)

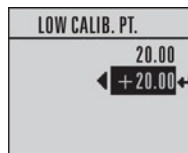
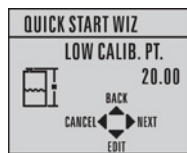

Values	Range: 0.00 to 20.00 m
--------	------------------------

High Calibration Point

Distance from Sensor reference point to High Calibration Point: usually process full level. (See **Operation** for an illustration.)

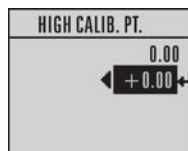
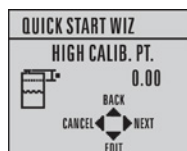

Values	Range: 0.00 to 20.00 m
--------	------------------------

Wizard complete

Options	BACK, CANCEL, FINISH (Display returns to 1.1 Quick Start Wiz menu when Quick Start is successfully completed.)
---------	--

Press **DOWN arrow**  (**Finish**). Then press **LEFT arrow**  to return to **Measurement** mode. SITRANS LR250 is now ready to operate.

6.2.3.2 Auto False Echo Suppression

If you have a vessel with known obstructions, we recommend using Auto False Echo Suppression to prevent false echo detection. See **TVT setup (2.8.7.)** for instructions.







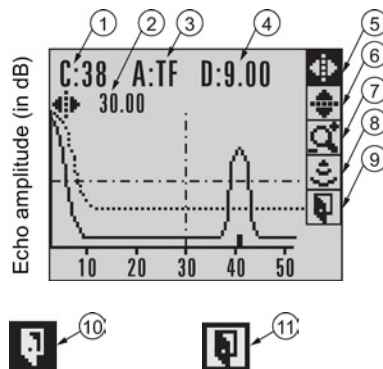
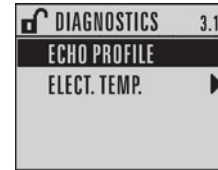

This feature can also be used if the display shows a false high level, or the reading is fluctuating between the correct level and a false high level.

6.2.3.3 Requesting an Echo Profile

- In **PROGRAM** mode, navigate to: **Level Meter > 3. > 3.1.**
- Press **RIGHT arrow**  to request a profile.



- | | |
|--|------------------------|
| ① Confidence | ⑦ Zoom |
| ② Distance from Low Calibration Point to vertical cross-hair | ⑧ Measure |
| ③ Algorithm: tF (trueFirst) | ⑨ Exit |
| ④ Distance from flange face to target | ⑩ Exit icon selected |
| ⑤ Pan left/right - selected | ⑪ Exit icon deselected |
| ⑥ Pan up/down | |

- Use **UP**  or **DOWN**  **arrow** to scroll to an icon. When an icon is highlighted, that feature becomes active.
- To move a cross-hair, press **RIGHT**  **arrow** to increase the value, **LEFT**  **arrow** to decrease.
- To Zoom into an area, position the intersection of the cross-hairs at the center of that area, select **Zoom**, and press **RIGHT**  **arrow**. Press **LEFT**  **arrow** to Zoom out.
- To update the profile, select **Measure** and press **RIGHT**  **arrow**.
- To return to the previous menu, select **Exit** then press **RIGHT**  **arrow**.

6.3 Application examples

Note

In the applications illustrated below, values are for example purposes only.

You can use these examples as setup references. Enter the values in the parameter tables to select the corresponding functions.

Configure the basic settings using the Quick Start wizard parameters. (These parameters are inter-related, and changes take effect only after you select **FINISH** to apply changes in the final step.)

In each example, after performing a Quick Start, navigate to the other required parameters either via the handheld programmer, or using a Device Management tool (SIMATIC PDM or AMS Device Manager) and enter the appropriate values.

6.3.1 Liquid resin in storage vessel, level measurement

Note

Minimum distance from flange face to target is limited by **Near Range (2.8.1.)**.

To obtain level measurement/4 to 20 mA output proportional to resin levels:

- Low Calibration Pt. = 5 m (16.5 ft) from sensor reference point
- High Calibration Pt. = 0.5 m (1.64 ft) from sensor reference point
- Max. fill/empty rate = 0.2 m/min (0.65 ft/min)

In the event of a loss of echo:

- SITRANS LR250 is to go into Fail-safe High after 2 minutes.

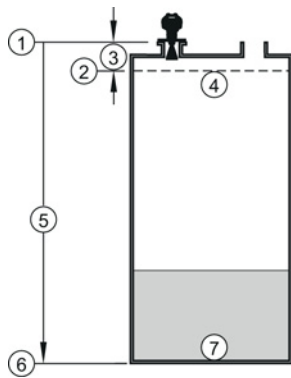

- | | | | |
|---|------------------------|---|-----------------------|
| ① | Sensor reference point | ⑤ | 5 m |
| ② | High calibration point | ⑥ | Low calibration point |
| ③ | 0.5 m | ⑦ | 0% level |
| ④ | 100% level | | |

Parameter type	Parameter No. /Name	Options/ Values	Function
Quick Start Wizard parameters	Introduction	NEXT	Continue with Wizard.
	Language	NEXT	Continue with current language.
	Material	LIQUID	
	Response Rate	MED	Medium = 1 m/minute
	Units	M	meters
	Operation	LEVEL	Level
	Low Calibration Point	5	5 m (16.5 ft)
	High Calibration Point	0.5	0.5 m (1.64 ft)
	Wizard Complete	FINISH	Transfers Quick Start settings to device.
Independent parameters	LOE Timer (2.5.2.)	2	2 minutes
	Material Level (2.5.1.)	HI	Fail-safe level set to High

Return to **Measurement**: press **Mode**  to start normal operation.

6.3.2 Horizontal vessel with volume measurement

Note

The minimum distance from the flange face to the target is limited by **Near Range (2.8.1.)**.

To obtain level measurement/4 to 20 mA output proportional to vessel volume in a chemical vessel:

- Low Calibration Point = 3.5 m (11.48 ft) from sensor reference point
- High Calibration Point = 0.5 m (1.64 ft) from sensor reference point
- Max. fill/empty rate = 0.2 m/min (0.65 ft/min)

Select vessel shape, Parabolic Ends, and enter values for A and L, to obtain a volume reading instead of level.

In the event of a loss of echo: SITRANS LR250 is to go into Fail-safe High after 2 minutes.

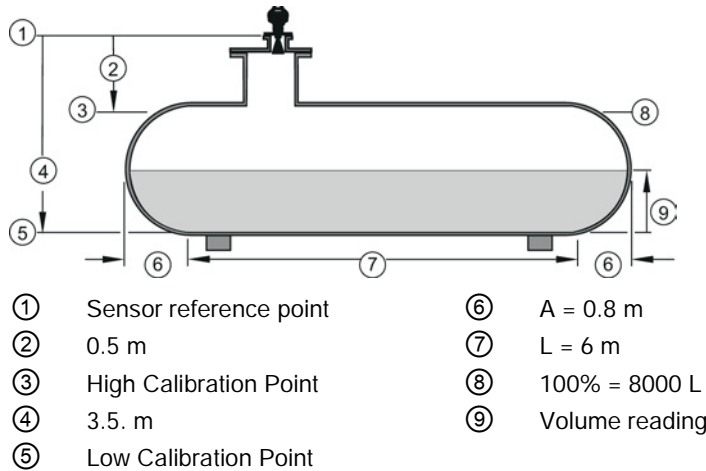

Parameter type	Parameter No./Name	Options/ Values	Function
Quick Start Wizard parameters	Introduction	NEXT	Continue with Wizard.
	Language	NEXT	Continue with current language.
	Material	LIQUID	
	Response Rate	MED	Medium =1 m/minute
	Units	M	meters
	Operation	LEVEL	Level is reported as Volume when a vessel shape is selected.
	Low Calibration Point	3.5	3.5 m (11.48 ft)
	High Calibration Point	0.5	0.5 m (1.64 ft)
	Wizard Complete	FINISH	Transfers Quick Start settings to device.
Independent parameters	Vessel Shape (2.7.1.1.)	PARABOLIC ENDS	Defines vessel shape.
	Maximum Volume (2.7.1.2.)	8000	8000 liters
	Vessel Dimension A (2.7.1.3.)	0.8	0.8 m (2.62 ft)
	Vessel Dimension L (2.7.1.4.)	6	6 m (19.68 ft)
	LOE Timer (2.5.2.)	2	2 minutes
	Material Level (2.5.1.)	HI	Fail-safe level set to High

Return to **Measurement**: press **Mode**  to start normal operation.

6.3.3 Application with stillpipe

Note

- **Near Range (2.8.1.)** (Blanking) will be set at the factory. Check the process connection tag for specific values.
- Suitable pipe diameters are 40 mm (1.5") to 100 mm (4").
- The pipe diameter must be matched with the antenna size. Use the largest antenna size that will fit the stillpipe/bypass pipe. See Dimensions (Page 209).
- See Mounting on a Stillpipe or Bypass Pipe (Page 32) for installation guidelines.

This application is to obtain a level measurement and corresponding 4 to 20 mA output proportional to the oil level in a fuel storage vessel.

- Low Calibration Pt. is 5 m (16.5 ft) from the sensor reference point.
- High Calibration Pt. is 0.5 m (1.65 ft) from the sensor reference point.
- The stillpipe inside diameter is 50 mm (1.96").
- The maximum rate of filling or emptying is about 0.1 m (4")/min.

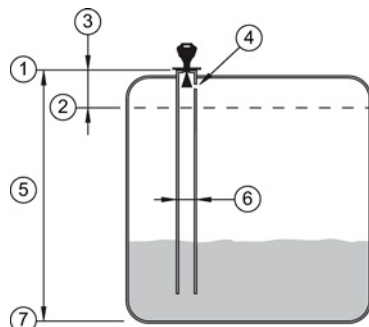

- | | | | |
|---|------------------------|---|-----------------------|
| ① | sensor reference point | ⑤ | 5 m |
| ② | high calibration point | ⑥ | 50 mm I.D. |
| ③ | 0.5 m | ⑦ | low calibration point |
| ④ | vent hole | | |

Parameter type	Parameter No./Name	Options/Values	Function
Quick Start Wizard	Introduction	NEXT	Continue with Wizard.
	Language	NEXT	Continue with current language.
	Material	LIQUID LOW DK	
	Response Rate	MED	Medium =1 m/minute
	Units	M	meters
	Operation	LEVEL	Level is reported as Volume when a vessel shape is selected.
	Low Calibration Point	5	5 m (16.5 ft)
	High Calibration Point	0.5	0.5 m (1.64 ft)
	Wizard Complete	FINISH	Transfers Quick Start settings to device.
Independent parameters	Propagation Factor (2.8.3.) ^{a)}	0.988	P.F. for a 50 mm (1.96") I.D. stillpipe
	Position Detect (2.8.4.2.)	HYBRID	
	CLEF Range (2.8.4.4.) ^{a)}	4.3	Low calibration point - 0.7 m = 4.3 m (14.1 ft)

^{a)} The recommended values for the propagation factor and for CLEF range are dependent on the stillpipe diameter. Refer to the next table for values.

Propagation Factor/Stillpipe Diameter

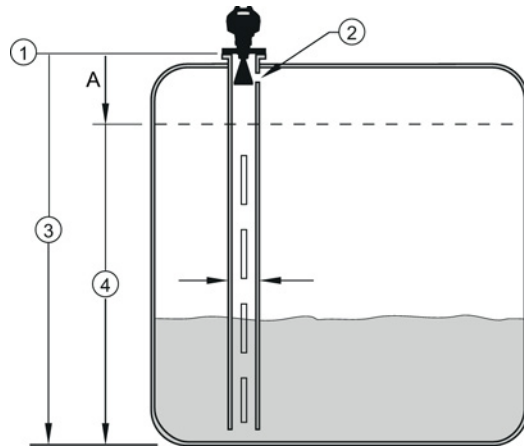

- ① sensor reference point
- ② air gap
- ③ low calibration point
- ④ CLEF range 2.8.4.4.
- A 700 or 1000 mm (see CLEF Range settings in table below)

Values	Range	0.3 to 1.0 depending on pipe size		
	Default	1.0000		
Nominal Pipe Size ^{a)}	40 mm (1.5")	50 mm (2")	80 mm (3")	100 mm (4")
Propagation Factor	0.9844	0.988	0.9935	0.9965
CLEF Range (2.8.4.4.) settings	Low calibration point - 700 mm (2.29 ft) ^{b)}	Low calibration point - 700 mm (2.29 ft) ^{b)}	Low calibration point - 1000 mm (3.28 ft) ^{b)}	Low calibration point - 1000 mm (3.28 ft) ^{b)}

- a) Since pipe dimensions may vary slightly, the propagation factor may also vary.
- b) CLEF range covers the whole measurement range except first 700 or 1000 mm from sensor reference point

Note

Flanged and Hygienic encapsulated antenna

For Flanged encapsulated antenna (7ML5432) and Hygienic encapsulated antenna (7ML5433) match the process connection size to the pipe diameter. For example, DN80/3" flange to DN80/3" pipe.

Remote operation

7.1 Operating via SIMATIC PDM

SIMATIC PDM is a software package used to commission and maintain process devices. Please consult the operating instructions or online help for details on using SIMATIC PDM. You can find more information on versions and compatibility at our website:

SIMATIC PDM (www.siemens.com/simatic-pdm).

7.1.1 Functions in SIMATIC PDM

Note

- For a complete list of parameters, see Parameter Reference (Page 127).
 - While the device is in **PROGRAM** mode the output remains fixed and does not respond to changes in the device.
-

7.1.1.1 PDM function overview

SIMATIC PDM monitors the process values, alarms and status signals of the device. It allows you to display, compare, adjust, verify, and simulate process device data; also to set schedules for calibration and maintenance.

Parameters are identified by name and organized into function groups. See LCD menu structure (Page 293) for a chart and Changing parameter settings using SIMATIC PDM (Page 86) for more details. The menu structure for SIMATIC PDM is almost identical to that for the LCD.

See Parameters accessed via pull-down menus (Page 87) for parameters that do not appear in the menu structure in SIMATIC PDM.

7.1.1.2 Features of SIMATIC PDM Rev. 6.0, SP4 or higher

The graphic interface in the device makes monitoring and adjustments easy.

Feature	Function
Quick Start (Page 81)	Device configuration for simple applications
Echo Profile Utilities (Page 88)	Easy access to echo profile viewing/comparison, TVT shaping, auto false echo suppression and echo setup
Auto False Echo Suppression (Page 92)	Screen out false echoes
TVT Shaper (Page 91)	Manual TVT adjustment
Process Variables (Page 99)	Monitor process variables and level trend
Security (Page 102)	Protect security and communication parameters from modification by the maintenance user

7.1.1.3 Features of SIMATIC PDM Rev. 5.2, SP1

SIMATIC PDM Rev. 5.2 SP1 is supported only for basic configuration and troubleshooting. For advanced features such as the Quick Start wizard, Rev. 6.0 SP3 HF2 or higher is required.

7.1.1.4 SIMATIC PDM Version

Check the support page of our website to make sure you have the latest version of SIMATIC PDM, the most recent Service Pack (SP) and the most recent hot fix (HF): SIMATIC PDM Version (<https://support.automation.siemens.com>). Browse to **Product Information > Automation Technology > Process control systems > SIMATIC PCS 7 > System components > SIMATIC PDM**.

7.1.2 Initial setup

To ensure that SIMATIC PDM connects properly, complete the following two processes:

1. De-activate buffers
2. Update the Electronic Device Description (EDD)

7.1.2.1 Deactivating buffers

This deactivation is required to align SIMATIC PDM with the HART modem for Windows 2000® and Windows® XP operating Systems. Windows® is a registered trademark of the Microsoft Corporation.

Note

- This deactivation is only necessary when you're connecting via RS232 (COM1) as opposed to USB.
- You will need administrative rights on your operating system to deactivate buffers.
- SIMATIC PDM operates only in the Windows XP Professional version, not in the Home version.

1. Click **Start/Settings/Control Panel** to begin configuration.
2. Double click **System**, select the **Hardware** tab, and click the **Device Manager** button.
3. Open **Ports** folder and double click the COM Port used by the system to open the **Communications Port Properties** window.
4. Select the **Port Settings** tab and double click the **Advanced** button.
5. If the **Use FIFO buffers** radio box is selected, click to deselect.

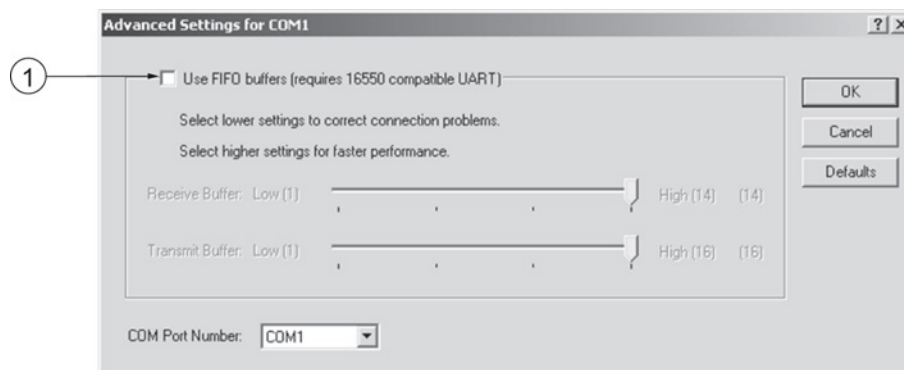

- ① Deselect **Use FIFO buffers** radio box

6. Click **OK** to close out. Close all screens and then reboot.

7.1.3 Updating the Electronic Device Description (EDD)

You can locate the EDD in Device Catalog, under **Sensors/Level/Echo/SiemensMilltronics/SITRANS LR250**. The EDD revision must match the Firmware revision in the device.

To install a new EDD:

1. Download the most current EDD from our website: Product page (<http://www.siemens.com/LR250>)
2. Save files to your computer, and extract the zipped file to an easily accessed location.
3. Launch **SIMATIC PDM – Manage Device Catalog**, browse to the unzipped EDD file and select it.

7.1.3.1 Configuring a new device

Note

- Clicking on **Cancel** during an upload from device to SIMATIC PDM will result in some parameters being updated.
 - Application Guides for setting up HART devices with SIMATIC PDM can be downloaded from our website:
Product page (<http://www.siemens.com/LR250>).
-

1. Check that you have the most recent EDD, and if necessary update it. [See Updating the Electronic Device Description (EDD) (Page 80) above].
2. Launch SIMATIC Manager and create a new project for the device.
3. Open the menu **Device – Master Reset** and click on **OK** to perform a reset to Factory Defaults.
4. After the reset is complete upload parameters to the PC/PG.
5. Configure the device via the Quick Start wizard.

7.1.4 Quick Start Wizard via SIMATIC PDM

The graphic Quick Start Wizard provides an easy step-by-step procedure that configures the device for a simple application.

Please consult the operating instructions or online help for details on using SIMATIC PDM.

1. If you have not already done so, check that you have the most up-to-date Electronic Device Description (EDD) for your device. [See Configuring a new device (Page 80).]
2. Launch SIMATIC Manager and create a new project. Application Guides for setting up HART and PROFIBUS PA devices with SIMATIC PDM can be downloaded from the product page of our website:
Product page (<http://www.siemens.com/LR250>)

Quick start

Note

- A reset to **Factory Defaults** should be performed before running the Quick Start Wizard if device has been used in a previous application. See Master Reset via SIMATIC PDM (Page 98).
- The Quick Start wizard settings are inter-related and changes apply only after you click on **FINISH AND DOWNLOAD** at the end of the last step to save settings offline and transfer them to the device.
- Do not use the Quick Start Wizard to modify individual parameters: for quick access to echo profile parameters, see Echo Profile via SIMATIC PDM (Page 89) or see Parameter Reference (Page 127) for a complete list. (Perform customization only after the Quick Start has been completed.)
- Click on **BACK** to return and revise settings or **CANCEL** to exit the Quick Start.
- For a vessel with obstructions see Auto False Echo Suppression via SIMATIC PDM (Page 92).

Launch SIMATIC PDM, open the menu **Device – Wizard - Quick Start**, and follow steps 1 to 5.

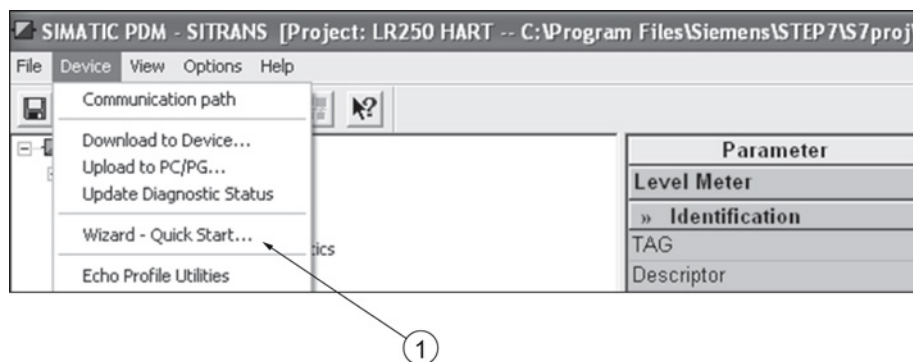

- ① Quick Start

Step 1 – Identification

Note

- The layout of the dialog boxes shown may vary according to the resolution setting for your computer monitor.
- SITRANS PDM limits the TAG field to a maximum of 24 characters.

1. Click on **Read Data from Device** to upload Quick Start parameter settings from the device to the PC/PG and ensure PDM is synchronized with the device.
2. If required, change the language for the local user interface.
3. Click on **NEXT** to accept the default values. (Description, Message, and Installation Date fields can be left blank.)

Quick Start - Step 1 of 5 - LR250

Step 1 of 5: Identification

SIEMENS

These parameters are used to identify the device. The TAG should be unique in your application. To identify and get all wizard parameters of the device, you can transfer the data from the device to SIMATIC PDM.

Read Data from Device

Identify the device:

TAG: LR250

Descriptor:

Message:

Installation Date:

Order Number: 7ML543x-xxx20

Select the language for local user interface:

Language: English

Cancel < Back Next > Help

Step 2 – Application

Select the application type (level or volume) and the material, then click on **NEXT**.

See Application with Stillpipe (Page 74) for a Low Dielectric Liquid application.

Quick Start - Step 2 of 5 - LR250

Step 2 of 5: Application

SIEMENS

These parameters specify the application type you wish to execute, and its according settings.

Select the Application Type:

Application Type: Level in a vessel

Material: Liquid

Cancel < Back Next > Help

Step 3 – Vessel Shape

The vessel shapes shown are predefined.

For a vessel with obstructions, see Auto False Echo Suppression via SIMATIC PDM (Page 92).

Select the vessel shape, and click on **NEXT**.

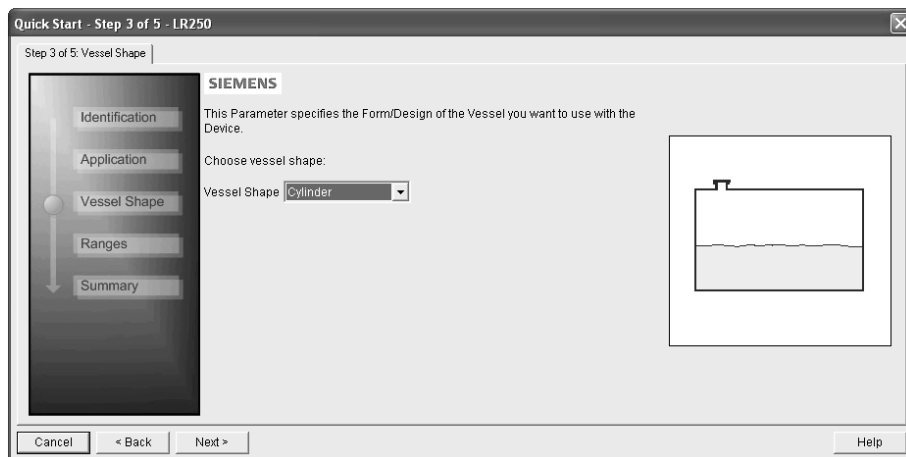
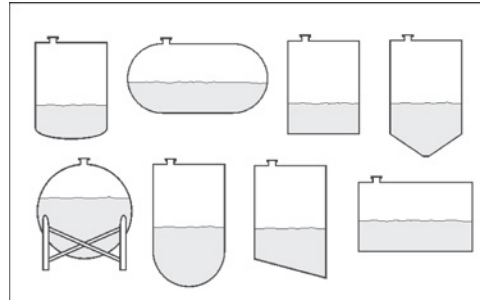

Step 4 – Ranges

Set the parameters, and click on **NEXT**.

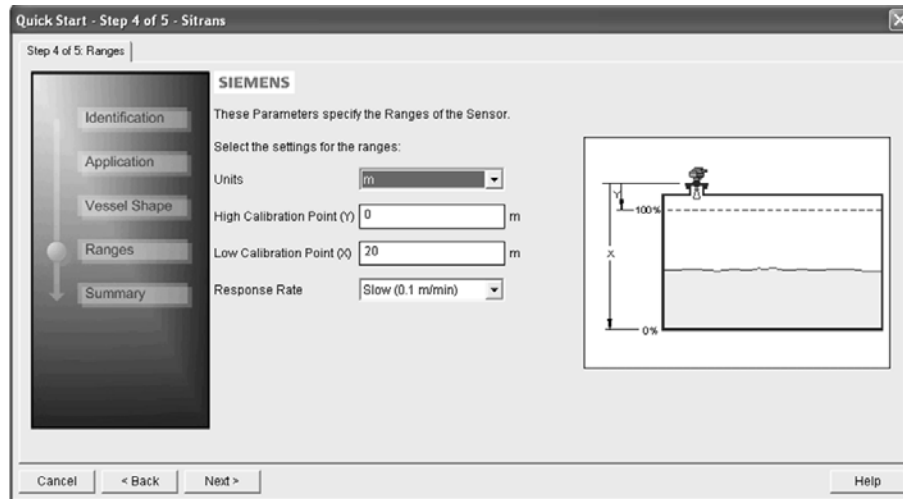

Step 5 – Summary

Check parameter settings, and click on **BACK** to return and revise values, **FINISH** to save settings offline, or **FINISH AND DOWNLOAD** to save settings offline and transfer them to the device.

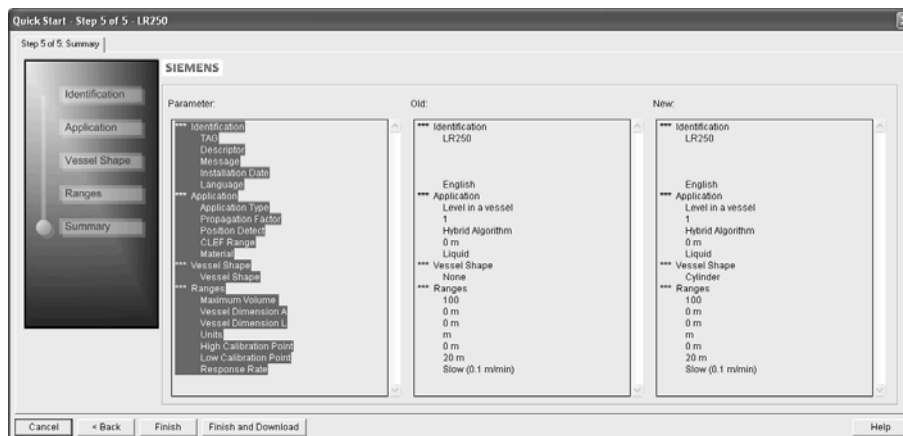

The message **Quick Start was successful** will appear. Click on **OK**.

7.1.5 Changing parameter settings using SIMATIC PDM

Note

- For a complete list of parameters, see Parameter Reference (Page 127).
- Clicking on **Cancel** during an upload from device to SIMATIC PDM will result in some parameters being updated.

Many parameters are accessed via pull-down menus in PDM. See Parameters accessed via pull-down menus (Page 87) for others.

1. Launch SIMATIC PDM, connect to device, and upload data from device.
2. Adjust parameter values in the parameter value field then **Enter**. The status fields read **Changed**.
3. Open the Device menu, click on **Download to device**, then use **File - Save** to save settings offline. The status fields are cleared.

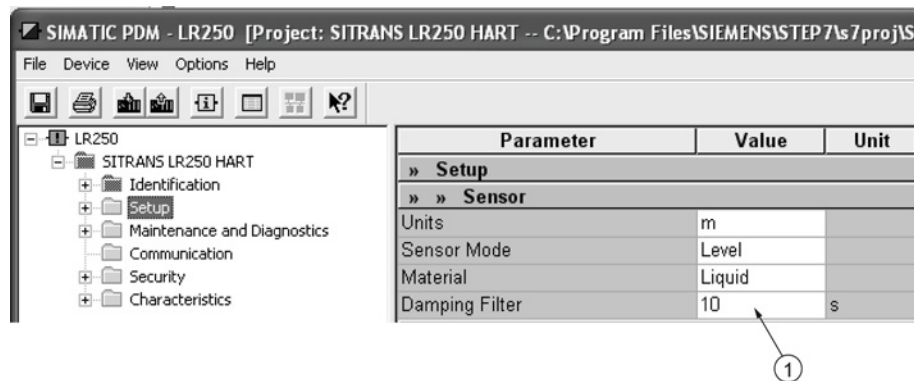

① Value fields

7.1.6 Parameters accessed via pull-down menus

Click on **Device** or **View** to open the associated pull-down menus.

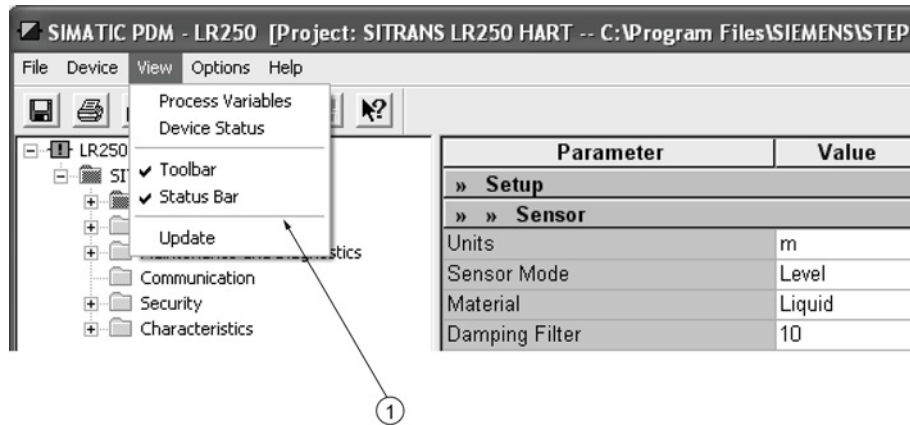

① pull-down menus

Pull-down menus

Device menus	View menus
Communication path	Process Variables (Page 99)
Download to device	Device Status (Page 101)
Upload to PC/PG	Toolbar
Update Diagnostic Status	Status bar
Wizard - Quick Start (Page 81)	Update
Echo Profile Utilities (Page 88)	
Maintenance (Page 95)	
Wear (Page 98)	
Select Analog Output (Page 97)	
Self Test (Page 97)	
Loop Test (Page 97)	
Configuration Flag Reset (Page 97)	
Master Reset (Page 98)	
HART Communication (Page 98)	

7.1.6.1 Echo profile utilities

Open the menu **Device – Echo Profile Utilities** and click on the appropriate tab for easy access to:

- Echo profile (Page 89)
- View Saved Echo Profiles (Page 90)
- TVT Shaper (Page 91)
- Auto False Echo Suppression (Page 92)
- Echo Setup (Page 95)

7.1.6.2 Echo profile

Note

- Double click on each axis to see the Xscale and Data Scale values.
- To zoom in to a section of the profile, left-click and drag a marquee around it. Right click inside the window to zoom out.
- Expand or compress the x and/or y axes:
 - Left-click on the axis and drag in either direction to reposition the low end of the scale.
 - Right-click on the axis and drag in either direction to reposition the high end of the scale.
- After saving a profile click on **OK**, not the **x** button, to close the Echo Profile Utilities window, otherwise the profile will not be saved.

- In the **Echo Profile Utilities** window click the **Echo Profile** tab.
- Initial profile graph is blank upon entry to dialog. Click **Measure** to update the profile.
- It is recommended to use the **Detailed** resolution view of the echo profile for troubleshooting. For faster and more coarse views, the **Standard** resolution may be used.
- Click **Save** and in the new window enter a name and click **OK**.
- Click **OK** to exit.

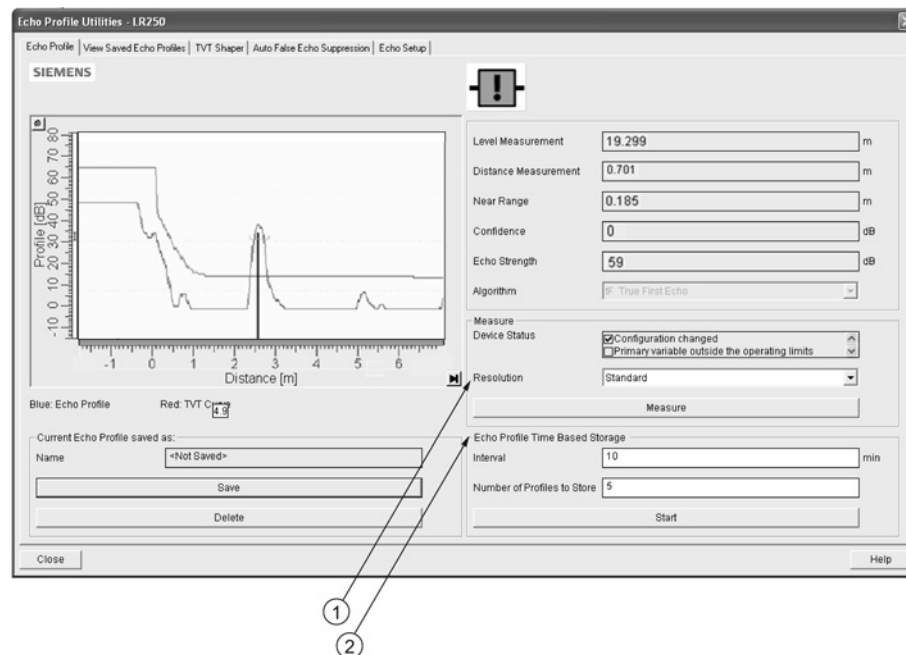

- ① Resolution
- ② Echo Profile Time Based Storage

7.1.6.3 View saved echo profiles

To view a saved profile, click on the tab **View Saved Echo Profiles**.

Echo profile data logging

You can store up to 60 profiles at a selected interval (maximum 60 minutes). Inside Echo Profile Utilities, in the **Echo Profile Time Based Storage** window:

- Enter the desired interval between stored profiles.
- Enter the maximum number of profiles to be stored (maximum 60).
- Click on **Start**. A message appears warning of the time delay and warning that all previous saved profiles will be overwritten. Click on **OK** to proceed. The new profiles will be saved with their date and time.
- Click on the tab **View Saved Echo Profiles** to view the stored profiles.

7.1.6.4 TVT Shaper

Note

Double click on each axis to see the X scale and data scale values. Right-click or Left-click on the axis and drag to reposition the scale.

This feature allows you to manually adjust the TVT to avoid false echoes caused by obstructions. For an explanation see Auto False Echo Suppression (Page 259).

Open the menu **Device – Echo Profile Utilities** and click the tab **TVT Shaper**.

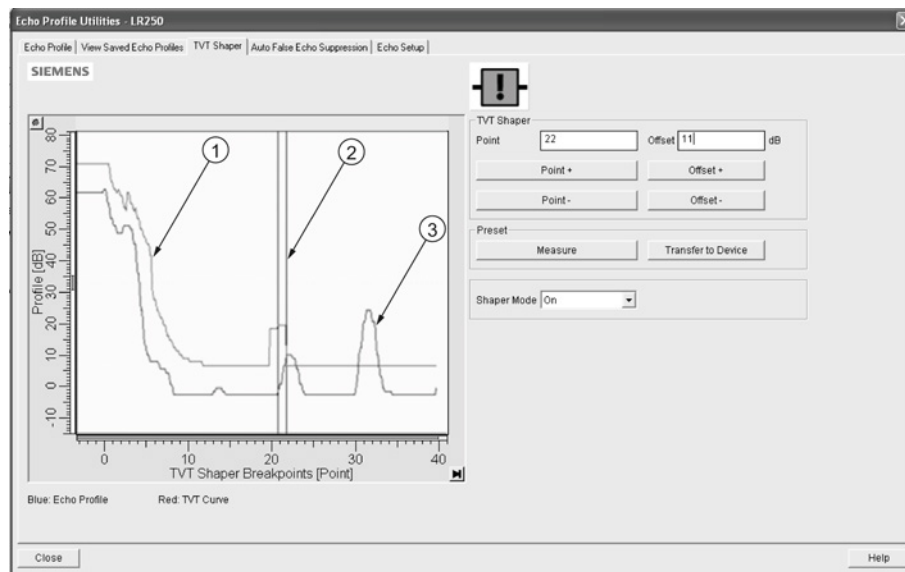

- ① TVT
- ② Cursor
- ③ Echo profile

- Initial profile graph is blank upon entry to dialog. Click on **Measure** to view and upload the current TVT from device.
- Change the position of the cursor on the TVT using the **Point+** and **Point-** buttons: raise and lower the TVT using **Offset+** and **Offset-**.
- Alternatively, enter values for **Point** and **Offset** directly into the dialog boxes.
- Click on **Transfer to Device**.

7.1.6.5 Auto false echo suppression

Note

- Ensure material level is below all known obstructions when using Auto False Echo Suppression to learn the echo profile. An empty or almost empty vessel is recommended.
 - Note the distance to material level when learning the echo profile, and set Auto False Echo Suppression Range to a shorter distance to avoid the material echo being screened out.
 - Set Auto False Echo Suppression and Auto False Echo Suppression Range during startup, if possible.
 - If the vessel contains an agitator it should be running.
 - Before adjusting these parameters, rotate the device for best signal (lower false-echo amplitude).
-

If you have a vessel with known obstructions, use Auto False Echo Suppression to prevent false echo detection. This feature can also be used if the device displays a false high level, or the reading is fluctuating between the correct level and a false high level.

The device learns the echo profile over the whole measurement range and the TVT is shaped around all echoes present at that moment. See Auto False Echo Suppression (Page 259) for a more detailed explanation.

The learned TVT will be applied over a specified range. The default TVT is applied over the remainder of the measurement range.

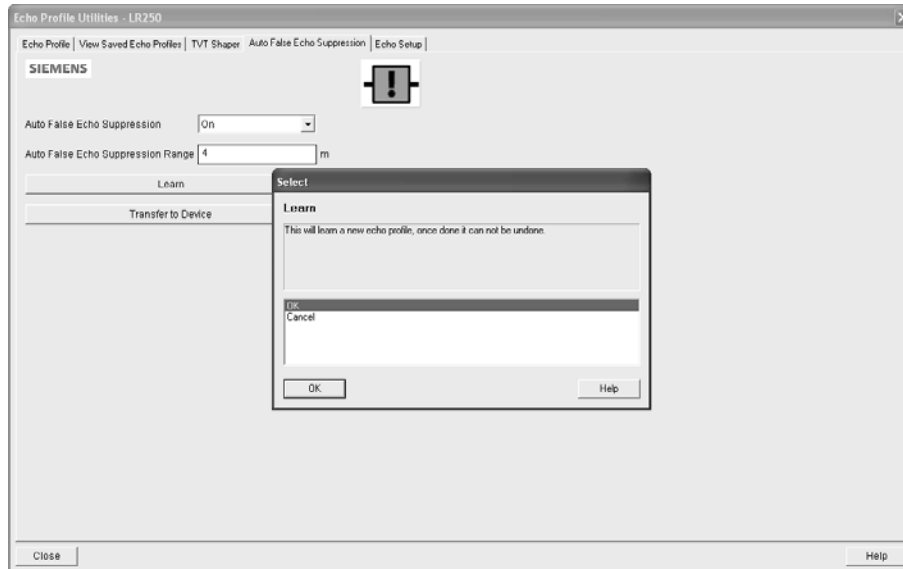

1. Make sure the material level is below all known obstructions.
2. Determine **Auto False Echo Suppression Range**. Measure the actual distance from the sensor reference point to the material surface using a rope or tape measure. Subtract 0.5 m (20") from this distance, and use the resulting value.
3. Open the menu **Device – Echo Profile Utilities** and click on the tab **Auto False Echo Suppression**.
4. Make sure **Auto False Echo Suppression Range** is **On**.
5. Enter the value for **Auto False Echo Suppression Range**.
6. Click **Learn**. The message appears: 'This will learn a new echo profile. Once done it cannot be undone'. Click **OK**.
7. Once Auto TVT is complete click **Transfer to Device**. To exit click **Close**. Auto TVT is enabled and the learned TVT will be used.
8. To turn **Auto False Echo Suppression** off or on, reopen the **Auto False Echo Suppression** window, change the Auto False Echo Suppression to **Off** or **On**, click on **Transfer to Device**.

Before Auto False Echo Suppression

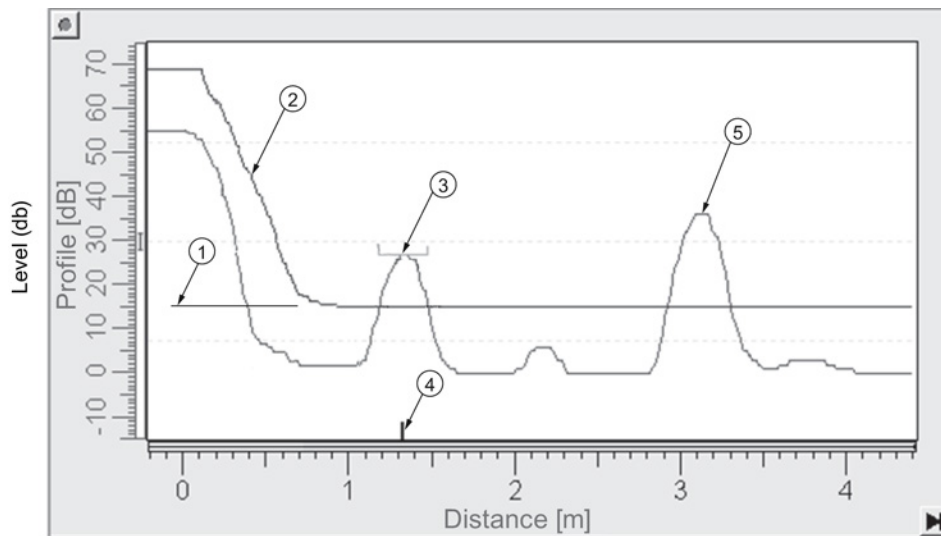

- | | | | |
|---|-----------------|---|----------------|
| ① | TVT Hover Level | ④ | Echo marker |
| ② | Default TVT | ⑤ | Material level |
| ③ | False echo | | |

After Auto False Echo Suppression

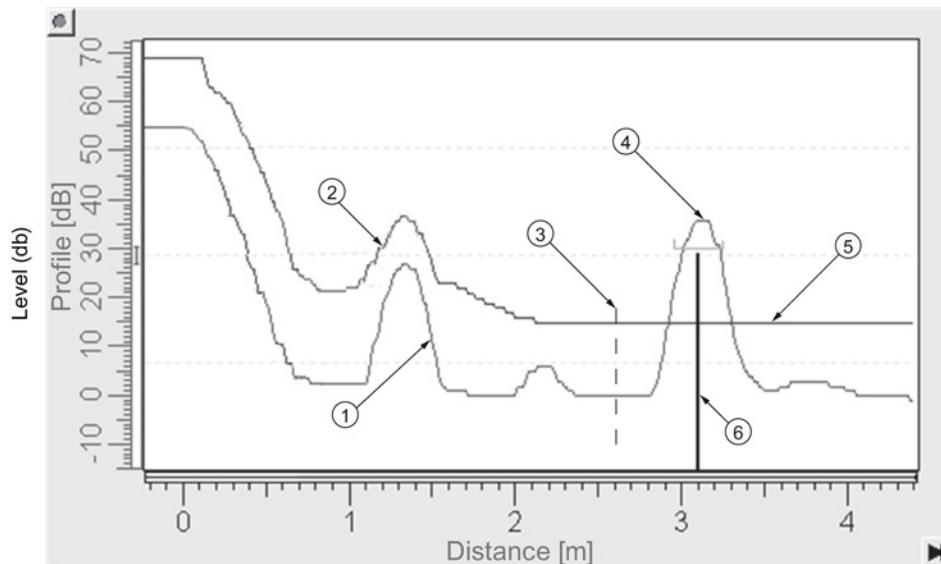

- | | | | |
|---|-----------------------------------|---|----------------|
| ① | False echo | ④ | Material level |
| ② | Learned TVT | ⑤ | Default TVT |
| ③ | Auto False Echo Suppression Range | ⑥ | Echo marker |

7.1.6.6 Echo setup

Provides quick access to echo selection, filtering, and response rate parameters.

Open the menu **Device – Echo Profile Utilities** and click on **Echo Setup**.

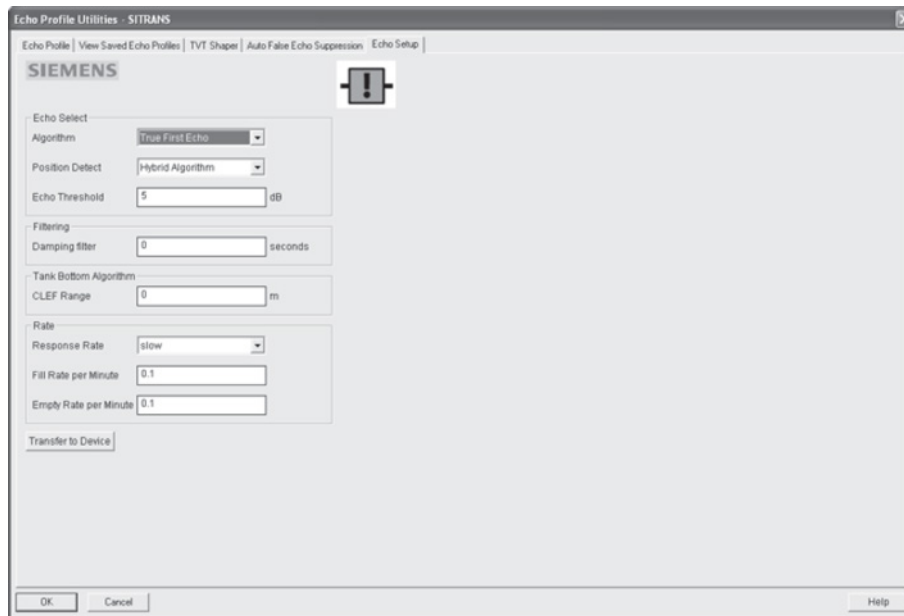

7.1.6.7 Maintenance

You can set schedules and reminders for:

- device maintenance based on its projected lifetime
- sensor maintenance based on its projected lifetime
- service
- calibration

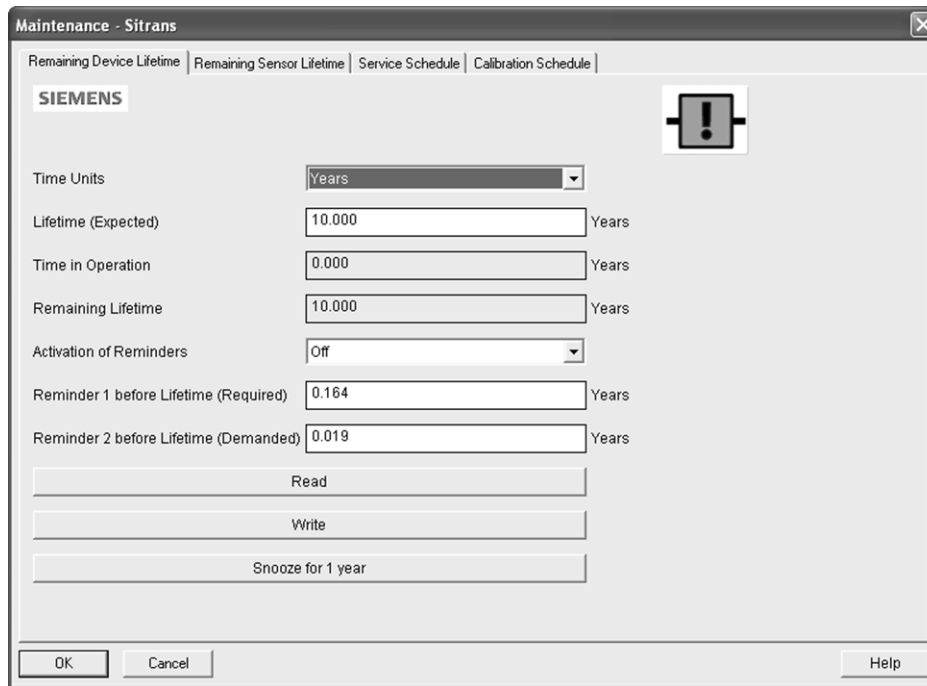

To set Device/Sensor Maintenance schedules:

1. Open the menu **Device – Maintenance**, and click on the **Remaining Device/Sensor Lifetime** tab.
2. Modify desired values, and if desired, set reminders for either or both of **Reminder 1 before Lifetime (Required)/Reminder 2 before Lifetime (Demanded)**.
3. Click **Write**.
4. Click **Read**, to see the effects of your modification.
5. Click **Snooze** to add a year to the Total Expected Device Life.

To set Service/Calibration schedules:

1. Open the menu **Device – Maintenance**, and click on the **Service/Calibration Schedule** tab.
2. Modify desired values and if desired, set reminders for either or both of **Reminder 1 before Lifetime (Required)/Reminder 2 before Lifetime (Demanded)**.
3. Click **Write**.
4. Click **Read**, to see the effects of your modification.
5. Click **Service/Calibration Performed** to reset the schedule.

7.1.6.8 Select analog output

Allows you to set the mA Output to report Level, Distance, Space, or Volume. See **Current Output Function (2.6.1.)** for an illustration.

If a volume application is selected, mA Output is automatically set to **Volume**. See Analog Output (Page 262) for more details.

1. Open the menu **Device – Select Analog Output**.
2. **Select Analog Output** window displays the current setting: click **OK**.
3. Select a different setting and click **OK**.
4. **Select Analog Output** window displays the new setting: click **OK**.

7.1.6.9 Self test

Checks memory (RAM and Flash). If there are no errors, returns the message 'Self Test OK.' If errors are found, returns the message 'Self Test Fails'.

Open the menu **Device – Self Test**, select **Yes** and click **OK**.

7.1.6.10 Loop test

Note

The simulated AO (Analog Output) value influences output to the control system.

Allows you to input a simulated value (4 mA, 20 mA, or a user-defined value) in order to test the functioning of the mA connections during commissioning or maintenance of the device. The range is 3.56 mA to 22.6 mA, see **mA Output Value (2.6.6.)**.

To simulate a user-defined mA value:

1. Open the menu **Device – Loop Test**.
2. Select **Other**, enter the new value, and click on **OK**. The message 'Field Device fixed at [new value]' appears. Click on **OK**. The Loop Test window remains open.
3. When you are ready to end simulation, select **End** and click on **OK** to return the device to the actual output value.

7.1.6.11 Configuration flag reset

To reset the configuration flag to zero, open the menu **Device – Configuration Flag Reset** and perform a reset.

7.1.6.12 Master reset

Factory Defaults

Factory Defaults resets all parameters to the default settings with the following exceptions:

- **Device Address (5.1.)** remains unchanged if the reset command is sent remotely (via AMS, PDM, DTM, FC375) but is reset to 0 if the reset command is sent via LUI.
 - **Write Protect (6.2.1.)** and **PIN to Unlock (6.2.2.)**
 - **Learned TVT curve, see Auto False Echo Suppression (2.8.7.1)**
1. Open the menu **Device – Master Reset**, select **Yes**, and click on **OK** to perform a reset to Factory Defaults.
 2. After the reset is complete upload parameters to the PC/PG. (If you are performing a reset after replacing the device with a different instrument, do not upload parameters to the PC/PG).

7.1.6.13 Wear

Reports the number of hours the device has been operating, and the number of times it has been powered up.

Open the menu **Device – Wear** to view:

- Powered Days
- Power-on Resets

Note

Powered days are whole days only. Fractional days are truncated.

7.1.6.14 HART Communication

Sets the number of request/response preambles (default 5).

The preamble consists of three or more hexadecimal FF characters (all 1s). This allows the receiving modem to get its frequency-detection circuits synchronized to the signal after any pause in transmission.

We recommend you do not change the default value (5).

7.1.6.15 Process variables

To compare outputs in real time open the menu **View – Process Variables** and click on **Overview** to see reading (level, space, distance, volume); analog output; device status; and current electronics temperature.

To see highest and lowest electronics temperatures, navigate to **Level Meter > Maintenance and Diagnostics > Electronics Temperature**.

Process Variables - SITRANS (Online)

Overview | Trend

SIEMENS

Display

Level Measurement	Space Measurement	Distance Measurement	Volume Measurement
18.931 m	1.069 m	1.069 m	0.000

Analog Out (PV)
 Analog Out(PV) = Level
 Level Measurement: 18.931 m
 The above value will not correspond to mA output while in fixed current mode.

Range: 94.65 %
 AO: 19.144 mA

Status of device
 Device Status

- Primary variable outside the operating limits
- Non-primary variable outside the operating limits
- Analog output outside the operating range limits
- Analog output in fixed mode
- More status available
- Cold start occurred
- Configuration changed
- Field device malfunctioned

Electronic Temperature: 22.89784 degC

Close Messages Help

7.1.6.16 Trend

Open the menu **View – Process Variables** and click on **Trend**.

Four trend lines can be monitored (distinguished by color in SIMATIC PDM):

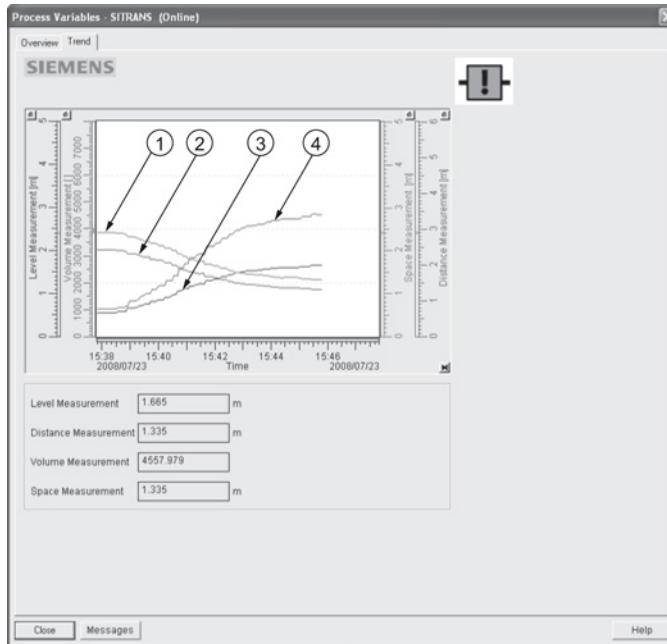

- ① Space
- ② Distance
- ③ Level
- ④ Volume

7.1.6.17 Device status

Open the menu **View – Device Status** to view Diagnostics, Device Status, Hardware/ Firmware (HW/FW) Status, and Maintenance status.

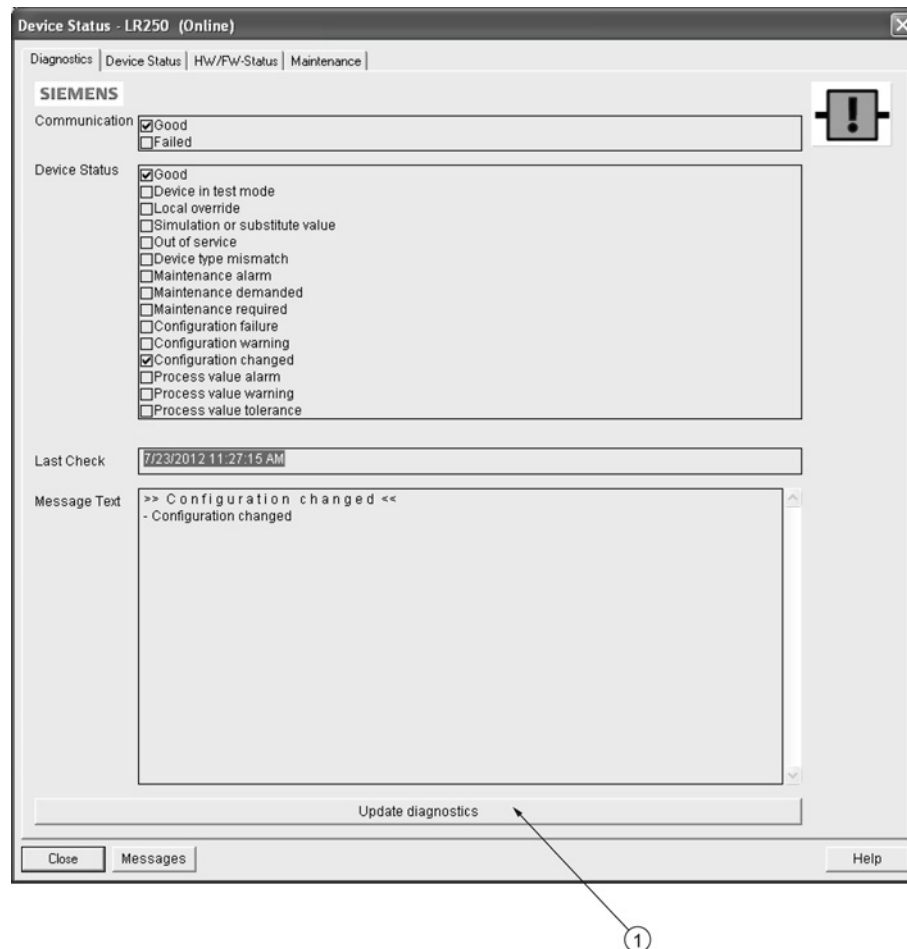

① update diagnostics

In the Diagnostics window, click on **Update diagnostics** to update diagnostic information and refresh linked icons.

7.1.6.18 Update

Open the menu **View – Update** to refresh the screen.

7.1.6.19 Security

A password option protects security and communication control parameters from modification by a maintenance user.

When you open a project the **User** dialog window provides two options: maintenance or specialist. If a password has been set it will not be possible to open the project as a specialist without it. A maintenance user will be able to open the project without a password but will not have access to security and communication control parameters.

1. Open a project, double-click on the device icon, and in the **User** window select **Specialist**.
2. Open the menu **Options – Settings** and click on the **Password** tab.
3. Enter a new password and re-enter it in the **Confirmation** window. Click on **OK**.

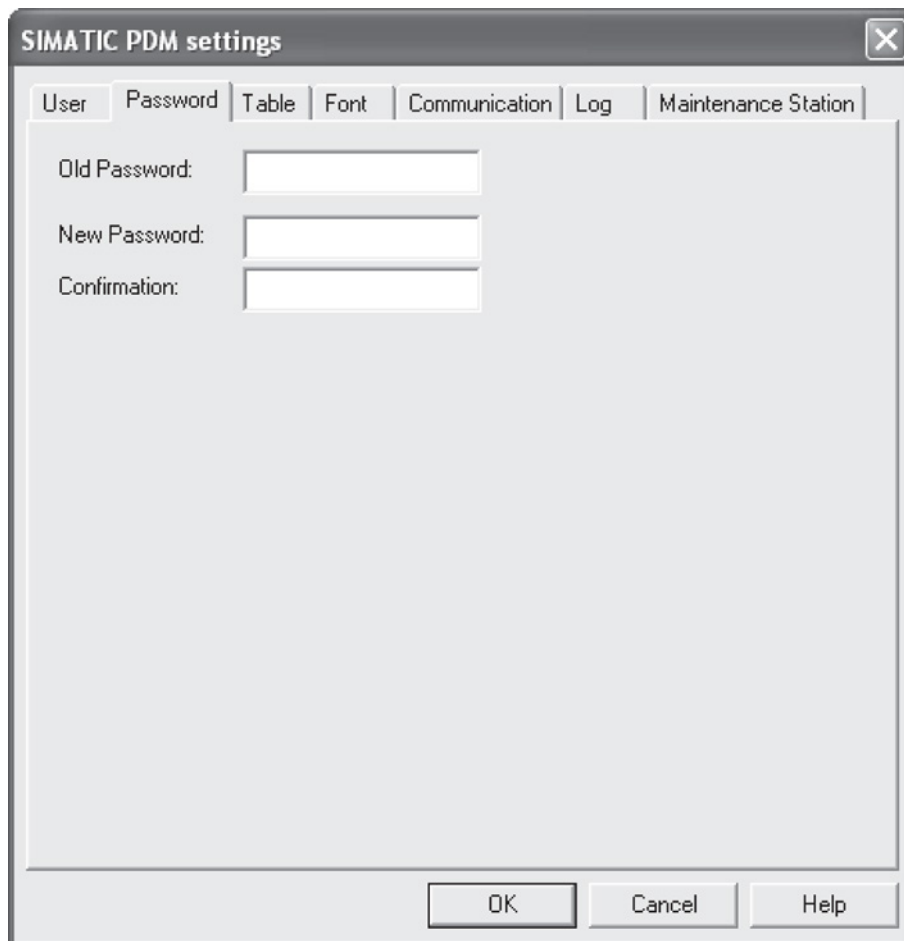

7.2 Operating via AMS Device Manager

AMS Device Manager is a software package that monitors the process values, alarms and status signals of the device. Please consult the operating instructions or online help for details on using AMS Device Manager. You can find more information at:

Emerson (<http://www.emersonprocess.com/AMS/>)

Application Guides for setting up Siemens HART devices with AMS Device Manager are available on our website:

Process automation (www.siemens.com/processautomation)

7.2.1 Functions in AMS Device Manager

Note

While the device is in PROGRAM mode the output remains fixed and does not respond to changes in the device.

7.2.1.1 AMS function overview

AMS Device Manager monitors the process values, alarms and status signals of the device. It allows you to display, compare, adjust, verify, and simulate process device data.

Parameters organized into three main function groups allow you to configure and monitor the device:

- Configure/Setup
- Device Diagnostics (read only)
- Process Variables (read only)

See AMS Menu Structure (Page 122) for a chart and Changing parameter settings using AMS Device Manager (Page 111) for more details. The menu structure for AMS Device Manager is almost identical to that for the LCD.

7.2.1.2 Features of AMS Device Manager

The graphic interface in the radar device makes monitoring and adjustments easy.

Feature	Function
Quick Start (Page 107)	Device configuration for simple applications
Echo Profile (Page 116)	Echo profile viewing
TVT (Page 115)	Screen out false echoes
Linearization (Page 109)	Volume measurement in an irregular vessel
Process Variables (Page 120)	Monitor process variables and level trend
Security (Page 118)	Protect security and communication parameters from modification by the maintenance user

7.2.1.3 Electronic Device Description (EDD)

The EDDs are linked to the type, version of configuration software, and protocol being used. Select the LR250 AMS EDD for the version of AMS installed. EDDs can be downloaded from our website, see Product page (<http://www.siemens.com/LR250>).

The HART EDD for LR250 is labeled as supporting AMS Device Manager version 9.5. This EDD is also operational with AMS version 9.0 and 10.1. There is also an application guide that details how to use the Hart Communication Foundation EDDs in AMS version 11.5 and above. There is no EDD for the LR250 for AMS version 10.5 to 11.1.

Please check the product page for updated EDDs and application guide.

7.2.1.4 Configuring a new device

1. Check our website to make sure you have the most recent EDD.
Product page (<http://www.siemens.com/LR250>)
Go to **Support > Software Downloads** and if necessary download it. Save the files to your computer, and extract the zipped file to an easily accessed location.
2. Launch **AMS Device Manager- Add Device Type**, browse to the unzipped EDD file and select it.

7.2.1.5 Startup

1. **Launch AMS Device Manager.** (Application Guides for setting up HART devices with AMS Device Manager can be downloaded from our website: Product page (<http://www.siemens.com/LR250>))
2. In **Device Connection View** right-click on the device icon and select **Scan Device** to upload parameters from the device.
3. Double click the device icon to open the startup screen. The startup screen shows device identification details, and a navigation window on the left-hand side of the screen.

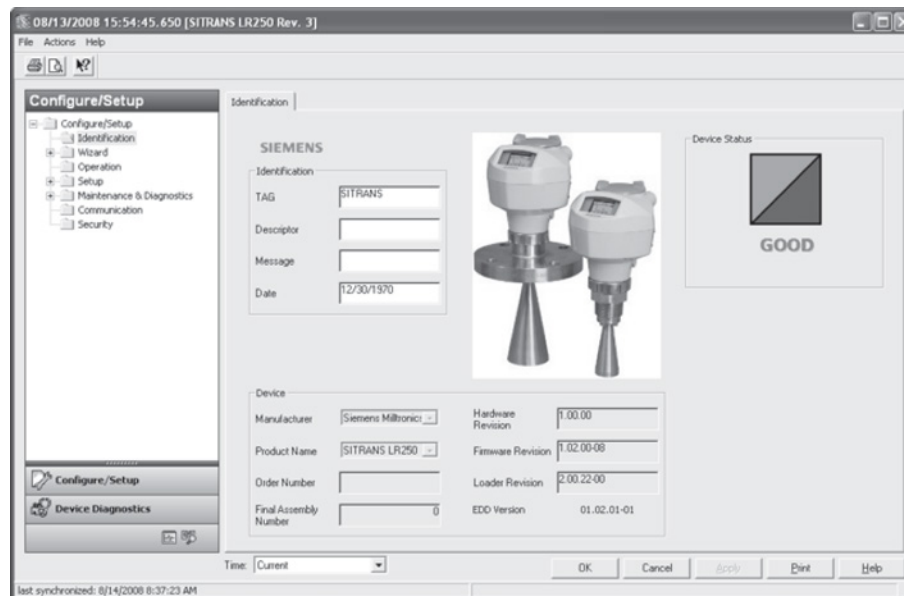

Master reset

Note

Device Address (5.1.) remains unchanged if the reset command is sent remotely (via AMS, PDM, DTM, FC375) but is reset to 0 if the reset command is sent via LUI.

- Navigate to **Configure/Setup > Operation**
- In the **General** field click on **Master Reset** and accept the option **Factory Defaults**.

7.2.1.6 Pull-down menu access

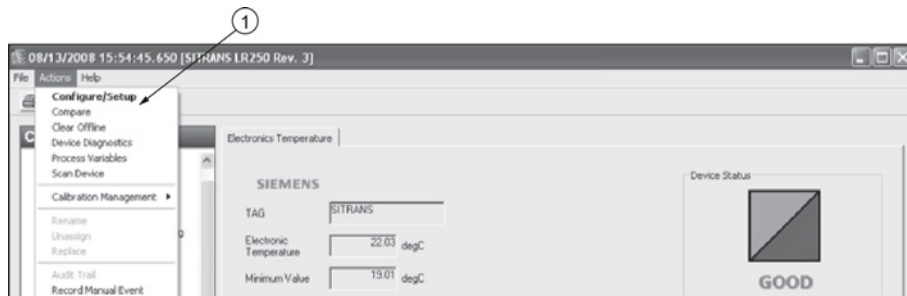

① Action menu items

A pull-down menu under **Actions** gives alternative access to several features.

Scan Device

- Open the menu **Actions – Scan Device**.
- **Scan Device** uploads parameters from the device (synchronizes parameters).

7.2.1.7 Device configuration

1. Navigate to **Configure/Setup > Operation** and click to open the dialog window.
2. In the **General** field, click on **Master Reset** and perform a reset to Factory Defaults.
3. Open the pull-down menu **Actions – Scan Device** to synchronize parameters (upload parameters from the device to AMS).
4. Configure the device via the Quick Start wizard.

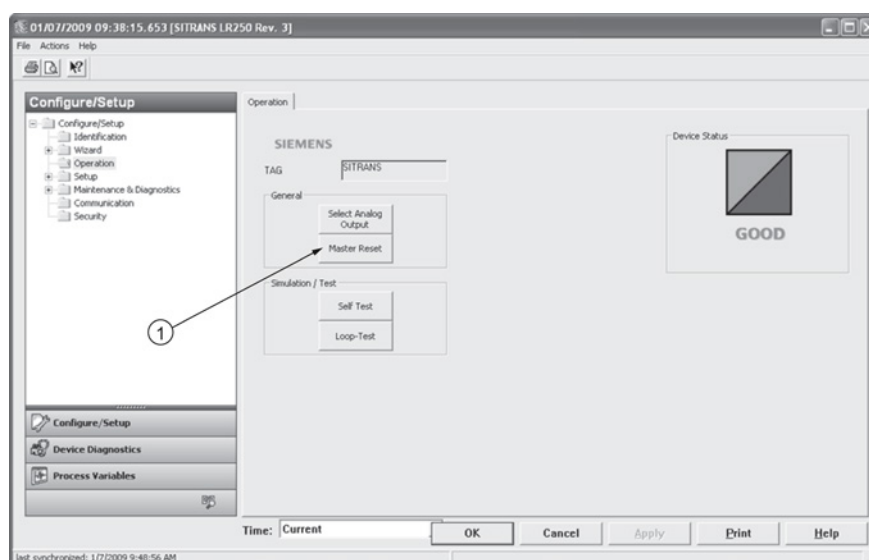

- ① Master reset

7.2.1.8 Quick Start Wizard via AMS Device Manager

Note

- A reset to Factory Defaults should be performed before running the Quick Start Wizard if device has been used in a previous application. See Master Reset (Page 105).
- The layout of the dialog boxes shown may vary according to the resolution setting for your computer monitor.
- At each step, you can accept the default values without modification and click on the next step to proceed.
- After modifying parameters click on **Apply** inside the Quick Start window to write the new values to the device.
- Click on **OK** only if you wish to update all parameters to the device and close AMS.

A Wizard provides an easy 5-step Quick Start procedure that configures the device for a simple application.

Quick Start

Step 1 – Identification

1. Navigate to **Configure/Setup > Wizard > Quick Start**.
2. Click on **Step 1**.
3. You can accept the default values without modification. (Description, Message, and Installation Date fields can be left blank.) If desired, make changes then click on **Apply**.

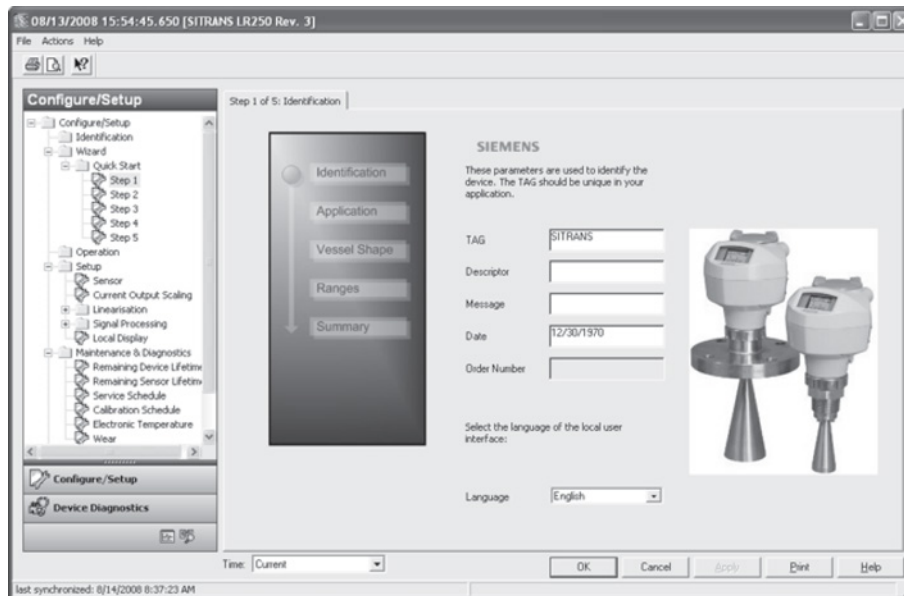

Step 2 – Application

1. Click on **Step 2**.
2. Select the application type (Level/vessel, Level/stillpipe, Level/bypass pipe, Volume/vessel, Volume/stillpipe, or Volume/bypass pipe) and the material (Liquid or Low dielectric liquid).
3. Click on **Apply**.

Step 3 – Vessel Shape

1. Click on **Step 3**.
2. Select a predefined vessel shape. To describe a more complex shape see Linearization (Page 109).
3. Click on **Apply**.

Step 4 – Ranges

1. Click on **Step 4**.
2. Change units if desired (in meters by default).
3. Set High and Low Calibration points.
4. To convert the reading from level to volume enter a value for Maximum Volume.
5. If a vessel shape with parabolic ends has been selected, set dimensions **A** and **L**.
6. Click on **Apply**.

Step 5 – Summary

Check parameter settings, and click on **Cancel** to abort, or **Apply** to transfer values to the device.

Linearization

You can use the linearization feature to define a more complex vessel shape and enter up to 32 level breakpoints where the corresponding volume is known. The values corresponding to 100% and 0% levels must be entered. The breakpoints can be ordered from top to bottom, or the reverse.

Using linearization via the Quick Start wizard

Navigate to **Configure/Setup > Wizard > Quick Start**.

In **Step 1 – Identification**, make any desired modifications and click on **Apply**.

In **Step 2 – Application**, select a level application and liquid as a material.

In **Step 3 – Vessel Shape**, choose the vessel shape option **Linearization Table**.

In **Step 4 – Ranges**, enter a value for maximum volume.

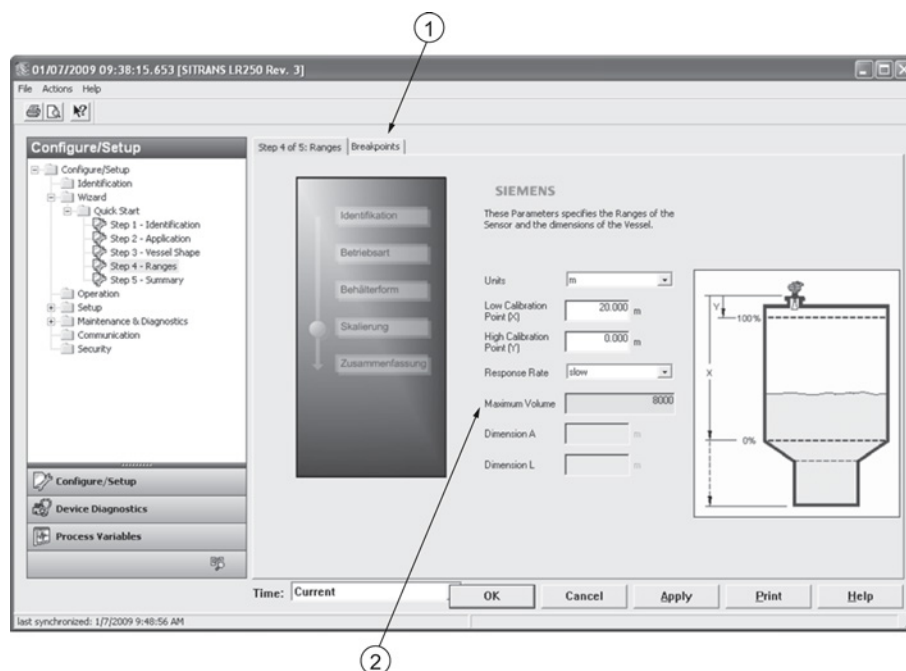

- ① Breakpoints
- ② Maximum volume

1. Click on the **Breakpoints** tab and enter values for level and volume for up to **32** breakpoints.
2. Navigate to **Configure/Setup > Setup > Linearization** and click on **Characteristic** to preview the characteristic curve of the vessel breakpoints. (The conversion will function correctly even if not all breakpoints are entered, but the curve will display correctly only if all breakpoints are entered.)
3. In **Step 5 – Summary**, check parameter values. Click on the appropriate step menu to return and revise values, or click on a different menu to exit **Quick Start**.

Changing parameter settings using AMS Device Manager

Note

For a complete list of parameters, see Parameter Reference (Page 127).

For more detailed explanations of the parameters listed below see the pages referenced.

1. Adjust parameter values in the parameter value field in Configure/Setup view, then click on **Apply** to write the new values to the device. The parameter field will display in yellow until the value has been written to the device.
2. Click on **OK** only if you wish to update all parameters and exit AMS.

Operation

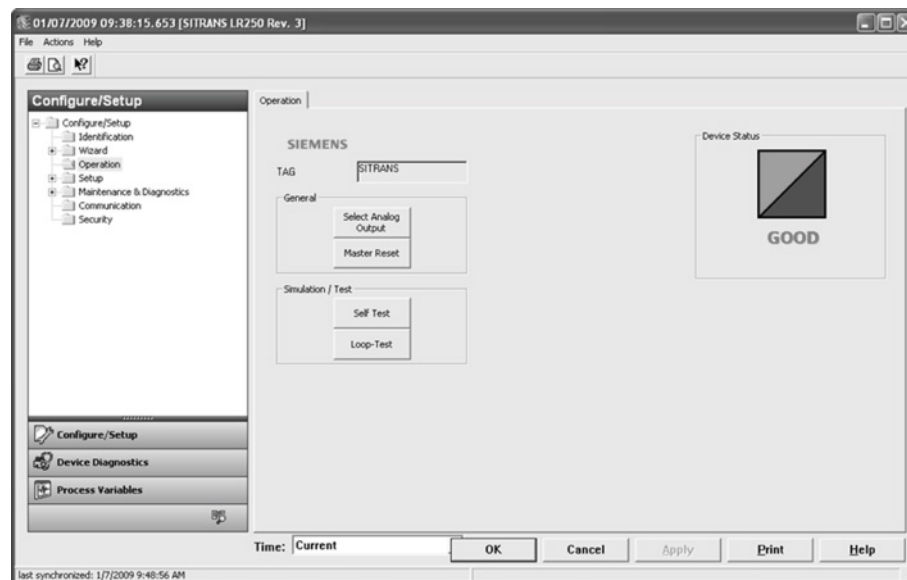

Navigate to **Configure/Setup > Operation** and click on **Operation** to open the dialog window for access to:

General

- Select Analog Output [see Select Analog Output (Page 97)]
- Master Reset [see Master Reset (Page 98)]

Simulation/Test

- Self Test [see Self Test (Page 97)]
- Loop Test [see Loop Test (Page 97)]

Setup

Note

For more detailed explanations of the parameters listed below see the pages referenced.

Sensor

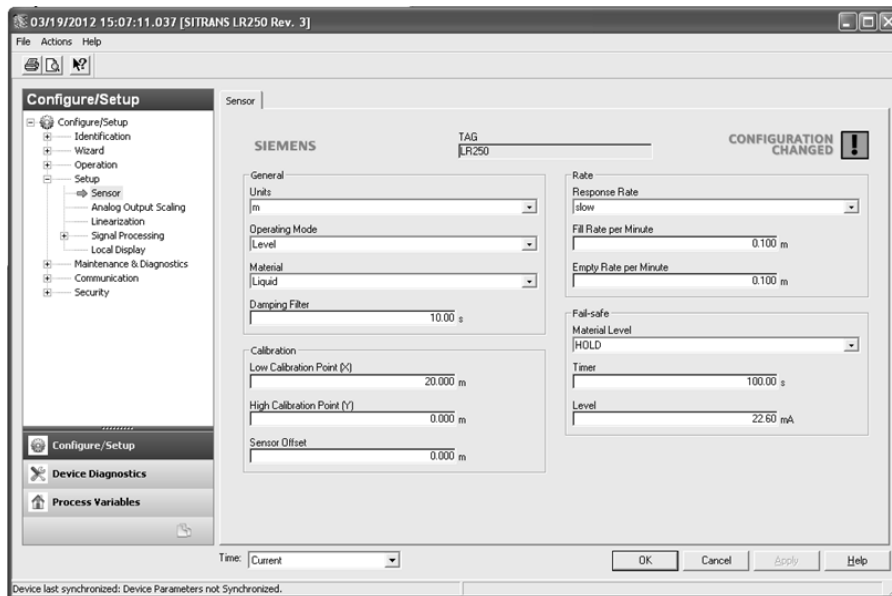

Navigate to **Configure/Setup > Setup** and click on **Sensor** for access to:

General [see Sensor (2.2.)]

- Units
- Operating Mode
- Material
- Damping Filter

Calibration [see Calibration (2.3.)]

- Low Calibration Point
- High Calibration Point
- Sensor Offset

Rate [see Rate (2.4.)]

- Response Rate
- Fill Rate per Minute
- Empty Rate per Minute

Fail-safe [see Fail-safe (2.5.)]

- Material level
- Timer
- Level

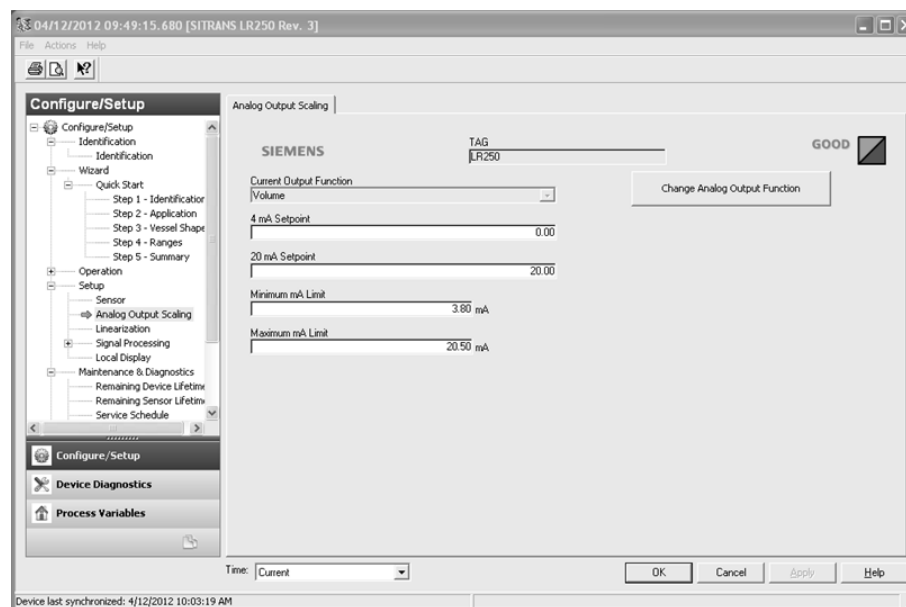
Analog Output Scale

Navigate to **Configure/Setup > Setup** and click on **Analog Output Scaling** for access to: Analog Output Scaling [see **Analog Output Scaling (2.6.)**]

- Current Output Function
- 4 mA Setpoint
- 20 mA Setpoint
- Minimum mA Limit
- Maximum mA Limit

Signal Processing

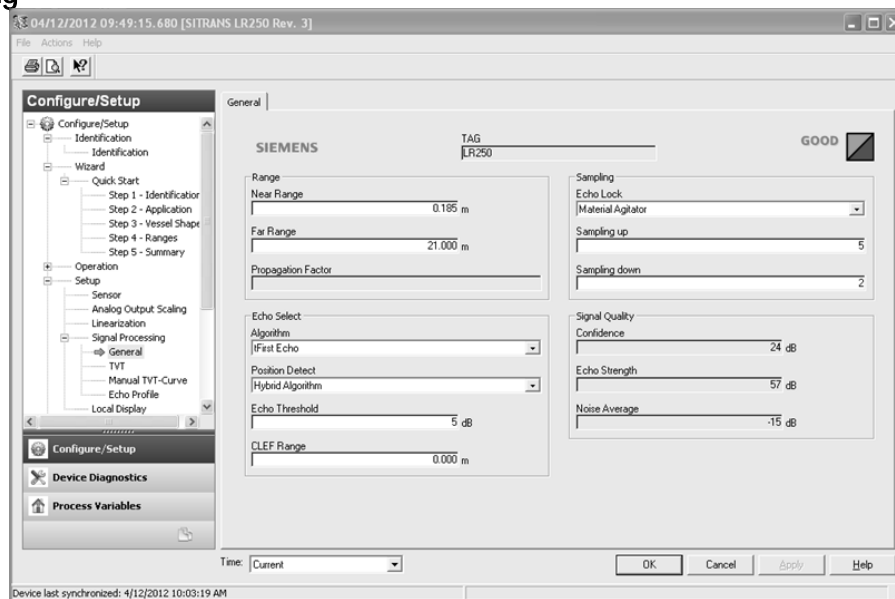

General

Navigate to **Configure/Setup > Setup > Signal Processing** and click on **General** for access to:
Range [see Signal Processing (2.8.)]

- Near Range
- Far Range
- Propagation Factor

Echo Select [see Echo Select (2.8.4.)]

- Algorithm
- Position Detect
- Echo Threshold
- CLEF Range

Sampling [see Sampling (2.8.5.)]

- Echo Lock
- Sampling Up
- Sampling Down

Signal Quality

- Confidence
- Echo Strength
- Noise Average

TVT

Modify the TVT to screen out false echoes. See Auto False Echo Suppression (2.8.7.1.) (Page 259).

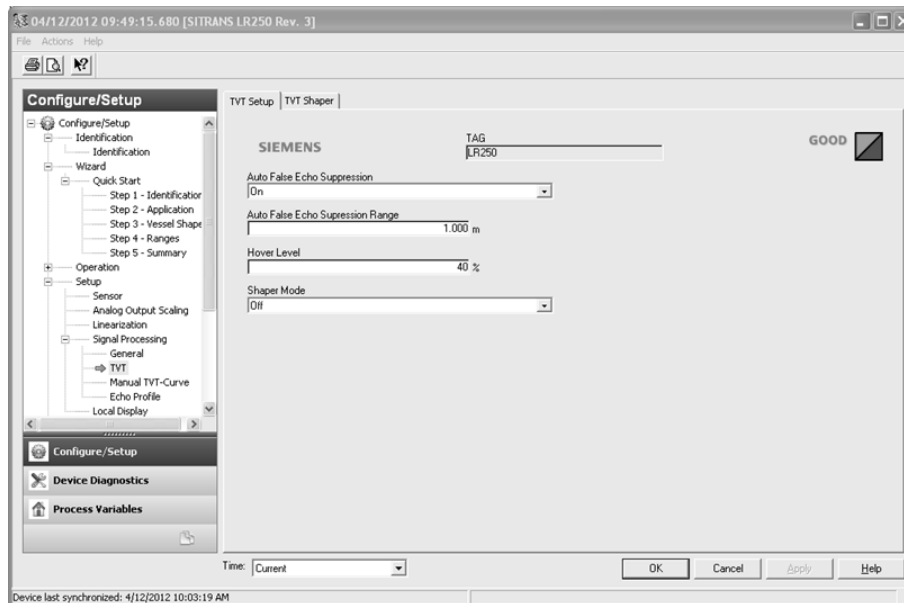

Navigate to **Configure/Setup > Setup > Signal Processing** and click on **TVT**. Click on one of the two tabs to access the parameters listed:

TVT Setup [see TVT setup (2.8.7.)]

- Auto False Echo Suppression
- Auto False Echo Suppression Range
- Hover Level
- Shaper Mode

TVT Shaper

- Shaper breakpoints 1 to 40. (Turn **TVT Setup/Shaper Mode** on to activate.)

Manual TVT Curve

Displays the effects of the TVT shaper modifications. Navigate to **Configure/Setup > Setup > Signal Processing** and click on **Manual TVT Curve**.

Echo Profile

- Navigate to **Configure/Setup > Setup > Signal Processing** and click on **Echo Profile**.
- Select **Standard** operation for faster display.

Local Display

Navigate to **Configure/Setup > Setup > Local Display** for access to:

- Language
- LCD Fast Mode [see **LCD Fast Mode (4.9.)**]
- LCD Contrast [see **LCD Contrast (4.10.)**]

7.2.2 Maintenance and diagnostics

Navigate to **Maintenance and Diagnostics** for access to:

Remaining Device Lifetime [see Remaining Device Lifetime (4.2.)]

- Lifetime (expected)
- Time in Operation
- Remaining Lifetime
- Activation of Reminders
- Reminder 1 before Lifetime (Required)
- Reminder 2 before Lifetime (Demanded)

Remaining Sensor Lifetime [see Remaining Sensor Lifetime (4.3.)]

- Lifetime (expected)
- Time in Operation
- Remaining Lifetime
- Activation of Reminders
- Reminder 1 before Lifetime (Required)
- Reminder 2 before Lifetime (Demanded)

Service Schedule [see Service Schedule (4.4.)]

- Service Interval
- Time Since Last Service
- Time Until Next Service
- Activation of Reminders
- Reminder 1 before Service (Required)
- Reminder 2 before Service (Demanded)

Calibration Schedule [see Calibration Schedule (4.5.)]

- Calibration Interval
- Time Since Last Calibration
- Time Until Next Calibration
- Activation of Reminders
- Reminder 1 before Calibration (Required)
- Reminder 2 before Calibration (Demanded)

Electronic Temperature

- Electronic Temperature
- Lowest Value
- Highest Value

Wear

- Powered Days
- Poweron Resets

See Wear via SIMATIC PDM (Page 98) for more detail.

7.2.3 Communication

Navigate to **Communication** to read the following:

Tag; Manufacturer's ID; Device ID; Product ID; Device Revision; EDD Revision; Universal Command Revision

7.2.4 Security

Navigate to **Configure/Setup > Security** to access:

Remote Access [see Remote Access (6.1.)]

Note

If access control is changed to limit remote access, it can only be reset via the handheld programmer. See **Access Control (6.1.1.)**.

- Write Protect (read only)
- Access Control

Local Access [see Local Access (6.2.)]

- Local Write Protected
- PIN to Unlock

See also Password Protection (Page 121).

7.2.5 Device Diagnostics

Click on the **Device Diagnostics** bar at the bottom of the navigation window, for access to:

Device Status

Hardware/Firmware Status

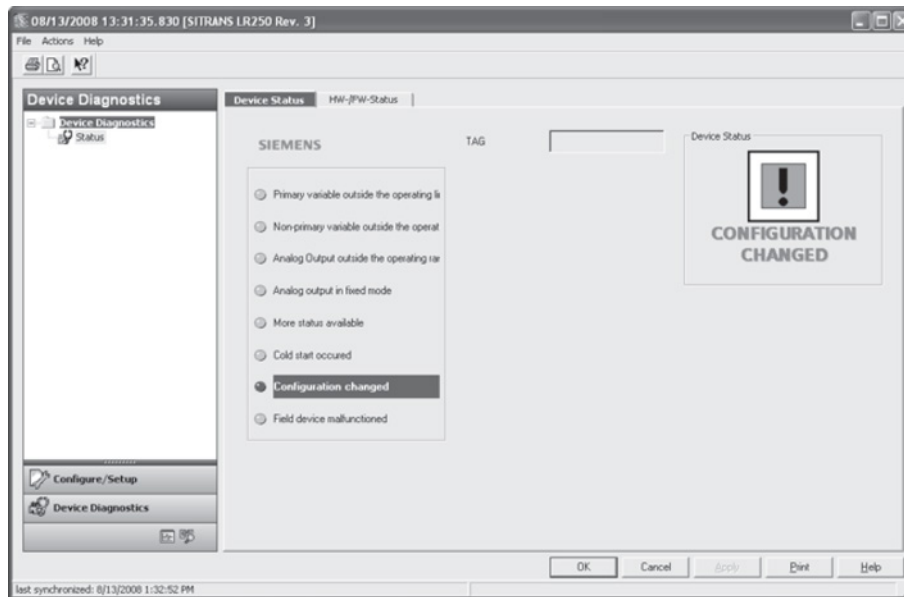

7.2.5.1 Process variables

To compare outputs in real time click on **Process Variables** at the bottom of the navigation window for access to:

Process Variables

- Values (level, volume, space, distance)
- Analog Output
- Trend View

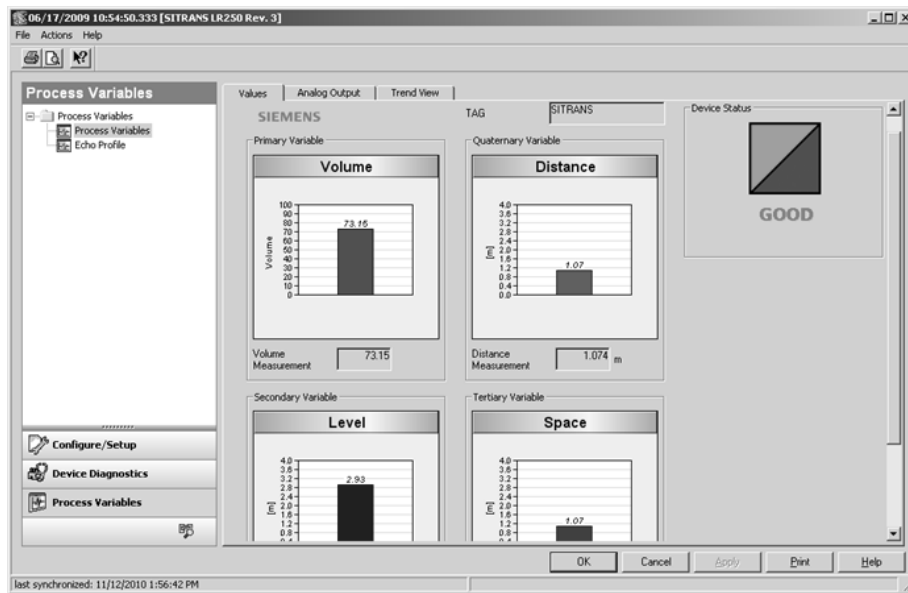

Echo Profile

7.2.5.2 Password protection

An AMS Device Manager administrator can configure the user to require a password. The use of passwords is recommended. A password should be assigned to the 'admin' username immediately after installing AMS Device Manager.

Each user is given an AMS Device Manager username and password and required to enter them when they start AMS Device Manager. Access to functions depends on the level of permissions granted.

Login types

- standard, local, or domain

A standard user can change their password in AMS Device Manager. A Local or Domain Windows user cannot change their password using AMS Device Manager and must request their network administrator to do so.

7.2.5.3 User Manager utility

Username, passwords, and permissions, are assigned to users by an AMS Device Manager administrator, using the User Manager utility on the Server Plus Station. Only a user with AMS Device Manager System Administration rights can log in to User Manager.

To configure a new user/edit existing user:

1. From the Windows taskbar select: **Start > AMS Device Manager > User Manager**.
2. In the User Manager window click on **Add User**.

The Add User Wizard dialog allows you to:

- select a user type, standard (AMS Device Manager) or Window user.
- enter the username and password, and set permissions
- edit existing users

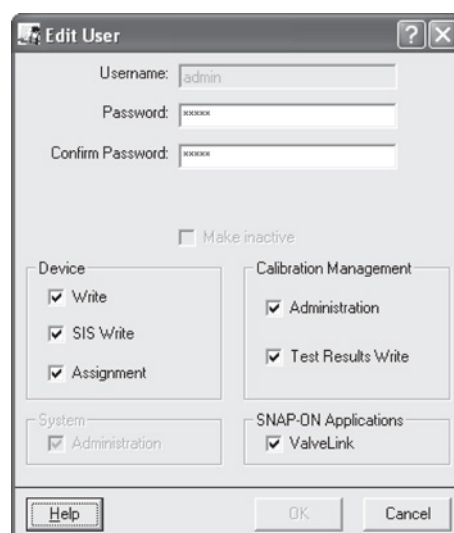

7.2.6 AMS menu structure

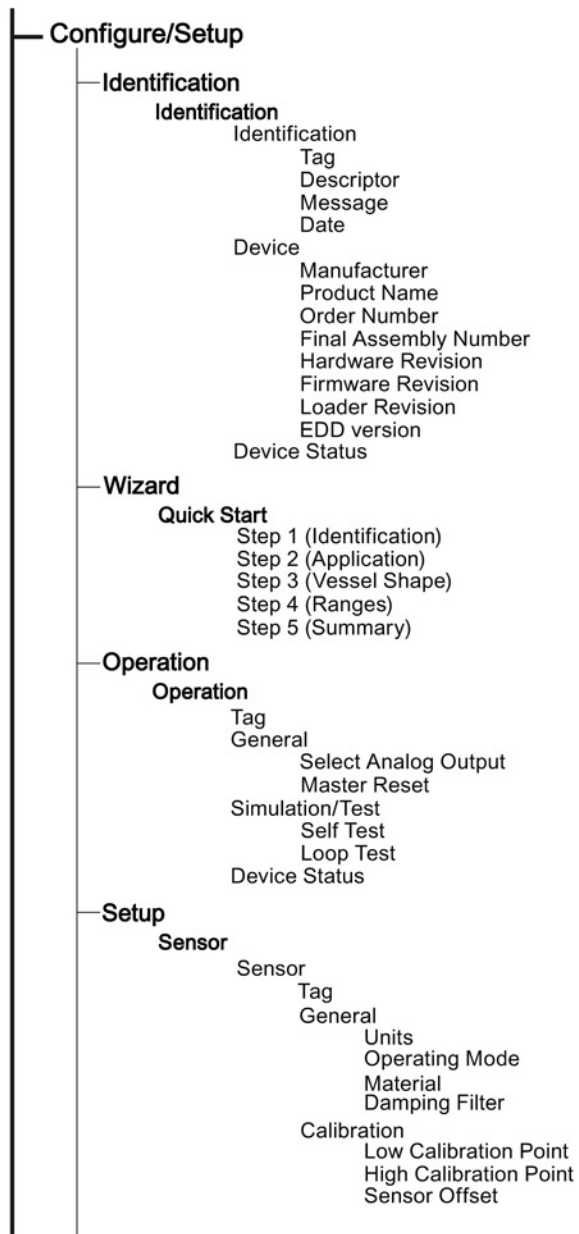

—	Configure/Setup (continued)
—	Setup/Sensor (continued)
	Rate
	Response Rate
	Fill Rate per Minute
	Empty Rate per Minute
	Fail-safe
	Material Level
	Timer
	Level
	Device Status
	Analog Output Scaling
	Analog Output Scaling
	Tag
	Current Output Function
	4 mA Setpoint
	20 mA Setpoint
	Minimum mA Limit
	Maximum mA Limit
	Device Status
	Linearization
	Vessel Shape
	Tag
	Vessel Shape
	Vessel Shape
	Vessel Dimensions
	Maximum Volume
	Dimension A
	Dimension L
	Device Status
	Breakpoints
	Tag
	Levels and Volume breakpoints
	Device status
	Vessel Shape
—	Signal Processing
	General
	General
	Tag
	Range
	Near Range
	Far Range
	Propogation Factor
	Echo Select
	Algorithm
	Position Detect
	Echo Threshold
	CLEF Range
	Sampling
	Echo Lock
	Sampling Up
	Sampling Down
	Signal Quality
	Confidence
	Echo Strength
	Noise average
	Device Status

- **Configure/Setup (continued)**
 - **Signal Processing (continued)**
 - **TVT**
 - TVT Setup
 - Tag
 - Auto False Echo Suppression
 - Auto False Echo Suppression Range
 - Hover Level
 - Shaper Mode
 - Device Status
 - TVT Shaper
 - Tag
 - Breakpoints
 - Device Status
 - Shaper Mode
 - **Manual TVT Curve**
 - Manual TVT diagram
 - Tag
 - Shaper Mode
 - **Echo Profile**
 - Echo Profile
 - Tag
 - Device Status
 - Echo Profile Parameters
 - Level Measurement
 - Distance Measurement
 - Confidence
 - Near Range
 - **Local Display**
 - **Local Display**
 - Tag
 - Language
 - LCD Fast Mode
 - LCD Contrast
 - Device Status
- **Maintenance and Diagnostics**
 - **Remaining Device Lifetime**
 - **Device Lifetime**
 - Tag
 - Lifetime (expected)
 - Time in Operation
 - Remaining Lifetime
 - Activation of Reminders
 - Reminder 1 before Lifetime (Required)
 - Reminder 2 before Lifetime (Demanded)
 - Device Status
 - **Remaining Sensor Lifetime**
 - **Sensor Lifetime**
 - Tag
 - Lifetime (expected)
 - Time in Operation
 - Remaining Lifetime
 - Activation of Reminders
 - Reminder 1 before Lifetime (Required)
 - Reminder 2 before Lifetime (Demanded)
 - Device Status

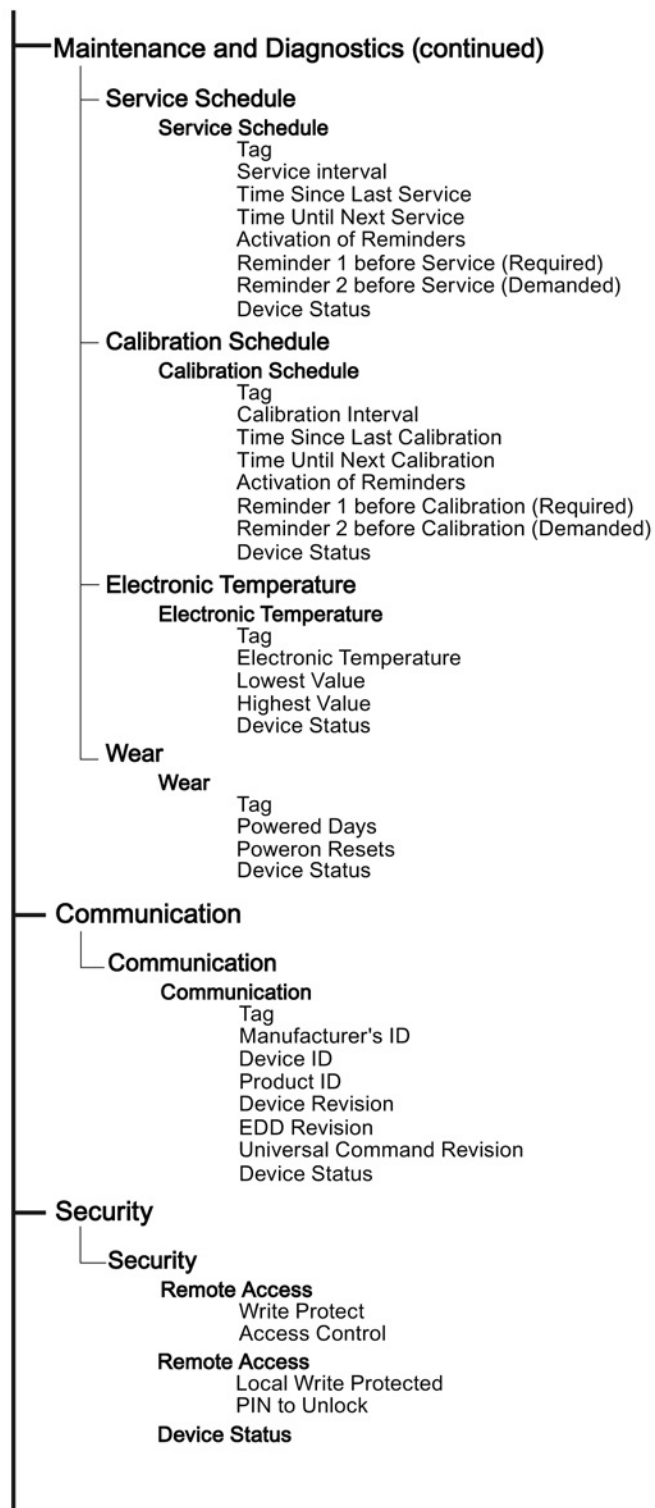

7.3 Operating via FDT (Field Device Tool)

FDT is a standard used in several software packages designed to commission and maintain field devices. Two commercially available FDTs are PACTware and Fieldcare.

Functionally FDT is very similar to PDM. See Operating via SIMATIC PDM (Page 77) for more detail.

- To configure a field device via FDT you need the DTM (Device Type Manager) for the device.
- To configure a field device via SIMATIC PDM, you need the EDD (Electronic Data Description) for the device.

7.3.1 Device Type Manager (DTM)

A DTM is a type of software that 'plugs into' FDT. It contains the same information as an EDD but an EDD is independent of the operating system.

7.3.2 SITRANS DTM

- SITRANS DTM is an EDDL interpreter developed by Siemens to interpret the EDD for that device.
- To use SITRANS DTM to connect to a device, you must first install SITRANS DTM on your system and then install the device EDD written for SITRANS DTM.
- You can download SITRANS DTM from the Siemens service and support website. Go to Service & Support (<http://www.siemens.com/automation/service&support>), click on **Product Support**, and drill down to **Product Information/Automation Technology/Sensor systems/Process Instrumentation/Software & Communications**.

7.3.3 The device EDD

The SITRANS LR250 HART EDD for SITRANS DTM can be downloaded from our website:

Product page (<http://www.siemens.com/LR250>).

Go to **Support > Software Downloads**.

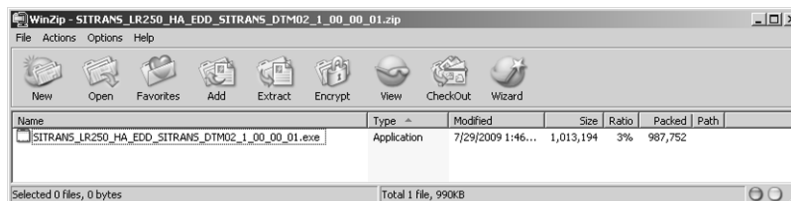







7.3.4 Configuring a new device via FDT

The full process to configure a field device via FDT is outlined in an Application Guide which can be downloaded from our website under **Support > Application Guides**.

Product page (<http://www.siemens.com/LR250>)

Parameter reference

Note

- Parameter names and menu structure are almost identical for SIMATIC PDM and the local user interface (LUI).
 - Default settings in the parameter tables are indicated with an asterisk (*) unless explicitly stated.
 - **Mode**  toggles between **PROGRAM** and **Measurement** Modes.
 - For Quick Access to parameters via the handheld programmer, press **Home** , then enter the menu number, for example: **2.2.1**.
 - In Navigation mode, **ARROW** keys (   ) navigate the menu in the direction of the arrow.
 - Press **RIGHT arrow**  to open **Edit Mode**, or to save a modification.
-

Parameters are identified by name and organized into function groups. See LCD menu structure (Page 293) for a chart. For AMS Device Manager the structure varies slightly.

Parameters accessible via the handheld programmer are followed by the device menu number in parenthesis. Parameters not followed by a number are accessible only via remote operation.

For more details see:

- Operating via SIMATIC PDM (Page 77)
- Operating via AMS Device Manager (Page 103)

Quick Start (1.)

Wizards provide step-by-step procedures to configure the device, filter out false echoes, and upload and download parameters and firmware to the optional display for easy configuration of multiple devices.

Quick Start Wizard (1.1.)

From measurement screen, press **RIGHT arrow** twice to open the Quick Start Wizard menu. Select a wizard, press **RIGHT arrow** to open the first step, and follow the instructions.

Note

Do not use the Quick Start Wizard to modify individual parameters. (Perform customization only after the Quick Start has been completed.)

- See Quick Start Wizard via the handheld programmer (Page 64).
- See Quick Start Wizard via SIMATIC PDM (Page 77).
- See Quick Start Wizard via AMS Device Manager (Page 107).

Setup (2.)

Note

Default settings in the parameter tables are indicated with an asterisk (*) unless explicitly stated.

Device (2.1.)

Hardware Revision (2.1.1.)

Corresponds to the electronics hardware of the SITRANS LR250.

Firmware Revision (2.1.2.)

Corresponds to the firmware that is embedded in the SITRANS LR250.

Loader Revision (2.1.3.)

Corresponds to the software used to update the SITRANS LR250.

Order Option (2.1.4.)

Read only. Displays the device type: standard or NAMUR NE 43-compliant.

Menu Timeout (2.1.5.)

Time menu stays visible before switching back to Measurement view if no key is pressed.

Sensor (2.2.)

Units (2.2.1.)

PV (Primary Value) and SV (Secondary Sensor measurement units). Used in setting High/Low Calibration Point, and displayed on LCD and in PDM.

Values	m, cm, mm, ft, in
	Default: m

Sensor Mode (2.2.2.)

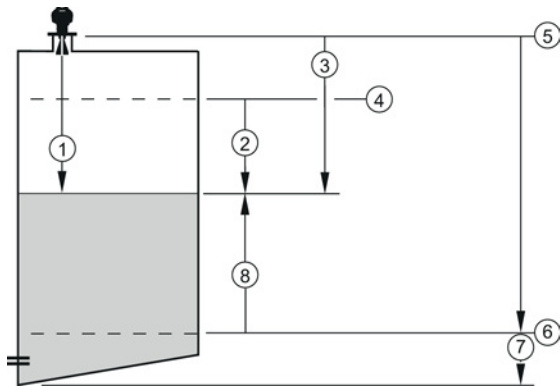

- ① Sensor value
- ② Space
- ③ Distance
- ④ High Calibration Point
- ⑤ Sensor reference point [see Dimension drawings] (Page 209)
- ⑥ Low Calibration Point
- ⑦ Far range
- ⑧ Level

Mode		Description	Reference point
NO SERVICE		Measurement and associated loop current are not updated, and the device defaults to Fail-safe mode ^{a)} .	n/a
LEVEL	*	Distance to material surface	Low Calibration Point (process empty level)
SPACE		Distance to material surface	High Calibration Point (process full level)
DISTANCE		Distance to material surface	Sensor reference point

^{a)} See **Material Level (2.5.1.)** for more detail.

Material (2.2.3.)

Automatically configures the device to operate in the chosen application type, by changing one or more of the following parameters: **Propagation Factor (2.8.3.)**, **Position Detect (2.8.4.2.)**, and/or **CLEF Range (2.8.4.4.)**.

Options	*	LIQUID
		LIQUID LOW DK ^{a)} (low dielectric liquid - CLEF algorithm enabled)
Related parameters	Propagation Factor (2.8.3.) Position Detect (2.8.4.2.) CLEF Range (2.8.4.4.)	

^{a)} $dK < 3.0$

You can configure each of the related parameters to suit your particular application.

Damping Filter (2.2.4.)

The time constant for the damping filter. The damping filter smooths out the response to a sudden change in level. This is an exponential filter and the engineering unit is always in seconds [see Damping (Page 262) for more detail].

Values	Range: 0 to 100.000 s
	Default: 10.000 s

Calibration (2.3.)

Note

We recommend using the Quick Start wizard to configure the device.

Low Calibration Pt. (2.3.1.)

Distance from sensor reference point¹⁾ to Low Calibration Point. Units are defined in **Units (2.2.1.)**

Values	Range: 0 to 20 m . Default: 20.00 m
Related parameters	Units (2.2.1.) Far Range (2.8.2.)

¹⁾ The point from which level measurement is referenced, see Threaded Horn Antenna with extension (Page 209), Flanged Horn with extension (Page 214), and Flanged encapsulated antenna (3"/DN80/80A sizes and larger) (Page 220).

High Calibration Pt. (2.3.2.)

Distance from sensor reference point ¹⁾ to High Calibration Point. Units are defined in **Units (2.2.1.)**.

Values	Range: 0 to 20 m. Default 0.00 m
Related parameters	Units (2.2.1.) Near Range (2.8.1.)

When setting the High Calibration Point value, note that echoes are ignored within **Near Range (2.8.1.)**.

¹⁾ The value produced by the echo processing which represents the distance from sensor reference point to the target. [see Threaded Horn Antenna with extension (Page 209), Flanged Horn with extension (Page 214), and Flanged encapsulated antenna (3"/DN80/80A sizes and larger) (Page 220)].

Sensor Offset (2.3.3.)

A constant offset that can be added to or subtracted from the sensor value¹⁾ to compensate for a shifted sensor reference point. (For example, when adding a thicker gasket or reducing the standoff/nozzle height.) The units are defined in **Units (2.2.1.)**.

Values	Range: -100 to 100 m. Default: 0.00 m
Related parameters	Units (2.2.1.)

¹⁾ The value produced by the echo processing which represents the distance from sensor reference point to the target, see **Sensor Mode (2.2.2.)**.

Rate (2.4.)

Response Rate (2.4.1.)

Note

Changing Response Rate resets **Fill Rate per Minute (2.4.2.)**, **Empty Rate per Minute (2.4.3.)**, and **Damping Filter (2.2.4.)**.

Sets the reaction speed of the device to measurement changes.

Response Rate (2.4.1.)		Fill Rate per Minute (2.4.2.)	Empty Rate per Minute (2.4.3.)	Damping Filter (2.2.4.)
*	Slow	0.1 m/min (0.32 ft/min)		10 s
	Medium	1.0 m/min (3.28 ft/min)		10 s
	Fast	10.0 m/min (32.8 ft/min)		0 s

Use a setting just faster than the maximum filling or emptying rate (whichever is faster).

Fill Rate per Minute (2.4.2.)

Defines the maximum rate at which the reported sensor value is allowed to decrease. Allows you to adjust the SITRANS LR250 response to decreases in the actual material level. Fill Rate is automatically updated whenever Response Rate is altered.

Options	Range: 0 to 99999 m / min.		
	Response Rate (2.4.1.)		Fill Rate per Minute (2.4.2.)
	*	Slow	0.1 m/min (0.32 ft/min)
		Medium	1.0 m/min (3.28 ft/min)
	Fast	10.0 m/min (32.8 ft/min)	
Altered by:	Response Rate (2.4.1.)		
Related parameters	Units (2.2.1.)		

Enter a value slightly greater than the maximum vessel-filling rate, in units per minute.

Sensor value is the value produced by the echo processing which represents the distance from sensor reference point to the target. See **Sensor Mode (2.2.2.)** for an illustration.

Empty Rate per Minute (2.4.3.)

Defines the maximum rate at which the reported sensor value is allowed to increase. Adjusts the SITRANS LR250 response to increases in the actual material level. Empty Rate is automatically updated whenever Response Rate is altered.

Options	Range: 0 to 99999 m / min.	
	Response Rate (2.4.1.)	
	*	Slow
		Medium
	Fast	10.0 m/min (32.8 ft/min)
Altered by:	Response Rate (2.4.1.)	
Related parameters	Units (2.2.1.)	

Enter a value slightly greater than the vessel's maximum emptying rate, in units per minute.

Sensor value is the value produced by the echo processing which represents the distance from sensor reference point to the target. See **Sensor Mode (2.2.2.)** for an illustration.

Fail-safe (2.5.)

Note

Default settings in the parameter tables are indicated with an asterisk (*) unless explicitly stated.

Material Level (2.5.1.)

Note

The default setting depends whether your device is a standard or NAMUR NE 43-compliant device.

Defines the mA output to use when the Fail-safe timer expires.

STANDARD DEVICE			
Options		HI	20.5 mA (max. mA Limit)
		LO	3.8 mA (min. mA Limit)
	*	HOLD	Last valid reading (default 22.6 mA)
		VALUE	User-selected value [defined in Fail-Safe mA Value (2.5.3.)]

NAMUR NE 43-COMPLIANT DEVICE ¹⁾			
Options		HI	20.5 mA (max. mA Limit)
		LO	3.8 mA (min. mA Limit)
		HOLD	Last valid reading
	*	VALUE	User-selected value [defined in Fail-Safe mA Value (2.5.3.) : default 3.58 mA]

¹⁾ Orderable option

LOE Timer (2.5.2.)

Note

When a Loss of Echo occurs **Material Level (2.5.1.)** determines the material level to be reported when the Fail-safe timer expires. See Loss of Echo (LOE) (Page 264) for more detail.

Sets the time to elapse since the last valid reading, before the Fail-safe Level is reported.

Values	Range: 0.00 to 7200 seconds
	Default: 100 s

Fail-Safe mA Value (2.5.3.)

Note

- The default settings are dependent on standard or NAMUR NE 43-compliant device.
- **Material Level (2.5.1.)** must be set to **VALUE** to enable the Fail-Safe mA Value to be reported.

Allows the user to define the mA value to be reported when the Fail-safe timer expires.

Device Type		STANDARD	NAMUR NE43- COMPLIANT
Values	Range	3.56 mA to 22.6 mA	
	Default	22.60 mA	3.58 mA

Analog Output Scaling (2.6.)

Current Output Function (2.6.1.)

Note

- **Level, space, and distance**, have different reference points.
- Use caution when changing Current Output Function while the device is connected to a HART network. Current Output Function controls the primary value and the loop current for the device.
- Current Output Function also affects the secondary, tertiary and quaternary variables in a HART network.

Can be set to either **Level, Space, Distance, or Volume**. (The device can carry out a volume calculation only after a vessel shape has been specified.)

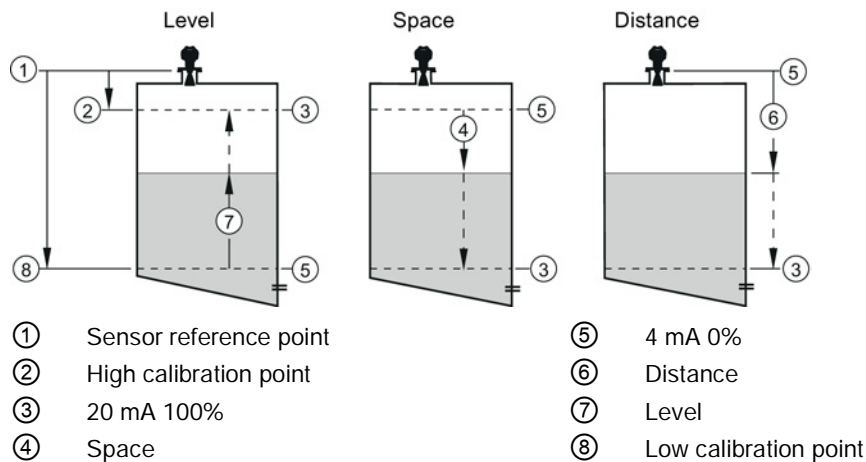

Options		Reference point	Description
*	Level	Low Calibration Point	measured as a percentage of the difference between High Calibration Point and Low Calibration Point
	Space	High Calibration Point	
	Distance	Sensor reference point	measured as a percentage of Low Calibration Point
	Volume	converts a level measurement to a volume output	
	Manual ^{a)} (LUI only)	allows mA Output Value (2.6.6.) to be set to a user-defined value	

a) Current Output Function must be set to **Manual** before modifying **mA Output Value (2.6.6.)**. Remember to restore the previous Current Output Function setting after modifying mA Output Value.

To view the mA reading in the secondary region of the LCD, press **5** on the handheld programmer.

To modify Current Output Function via SIMATIC PDM:

- Open the menu **Device – Select Analog Output**. See Select Analog Output via SIMATIC PDM (Page 97) for more detail.

4 mA Setpoint (2.6.2.)

Sets the process level corresponding to the 4 mA value. 4 mA always defaults to **0**, and **Current Output Function (2.6.1.)** determines whether this is a Level, Space, Distance, or Volume measurement. (See **Current Output Function (2.6.1.)** for an illustration.)

Values	Range: -999999 to +999999 (limits vary with current function and units)
	Default: 0.00 m (set to value corresponding to 0% as defined by Current Output Function)
Related Parameters	Units (2.2.1.)
	Current Output Function (2.6.1.)

- Enter the reading that is to correspond to a 4 mA output.
- Units are defined in **Units (2.2.1.)** for Level, Space, or Distance. Units are unspecified for Volume.

20 mA Setpoint (2.6.3.)

Sets the process level corresponding to the 20 mA value. 20 mA always defaults to 100%, and **Current Output Function (2.6.1.)** determines whether this is a Level, Space, or Distance measurement. (See **Current Output Function (2.6.1.)** for an illustration.)

Values	Range: -999999 to +999999 (limits vary with current function and units)
	Default: 20.00 m (set to value corresponding to 100% as defined by Current Output Function)
Related Parameters	Units (2.2.1.)
	Current Output Function (2.6.1.)

- Enter the reading that is to correspond to a 20 mA output.
- Units are defined in **Units (2.2.1.)** for Level, Space, or Distance. Units are unspecified for Volume.

Minimum mA limit (2.6.4.)

Prevents the mA output from dropping below this minimum level for a measurement value. This does not restrict the Fail-safe or Manual settings.

Values	Range: 3.8 to 20.5 (mA)
	Default: 3.8 (mA)

Maximum mA limit (2.6.5.)

Prevents the mA output from rising above this maximum level for a measurement value. This does not restrict the Fail-safe or Manual settings.

Values	Range: 3.8 to 20.50 (mA)
	Default: 20.50 (mA)

mA Output Value (2.6.6.)

Allows you to use a simulated value to test the functioning of the loop. You can enter 4 mA, 20 mA, or any other user-defined value within the range.

Values	Range: 3.56 mA to 22.6 mA
	Read Only unless Current Output Function (2.6.1.) is set to Manual.
Related parameter	Current Output Function (2.6.1.)

1. First set **Current Output Function (2.6.1.)** to **Manual**.
2. Enter the desired mA value in mA Output Value.
3. After completing the test, remember to reset **Current Output Function (2.6.1.)** to the previous setting.

Via SIMATIC PDM:



Open the menu Device – Loop Test. For more detail, see Loop Test (Page 97).

Linearization (2.7.)**Volume (2.7.1.)**

Carries out a volume conversion from a level value.

Vessel Shape (2.7.1.1.)

Defines the vessel shape and allows the LR250 to calculate volume instead of level. If **None** is selected, no volume conversion is performed. Select the vessel shape matching the monitored vessel or reservoir.

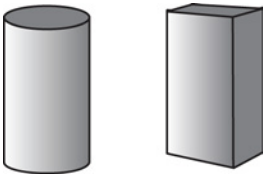
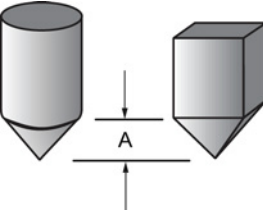
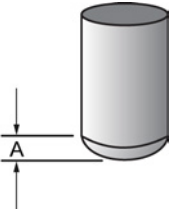
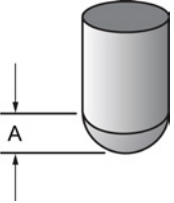
	Vessel Shape	LCD DISPLAY/ Description	Also required
*	None	NONE/ No volume calculation required	N/A
		CYLINDER/ Flat end horizontal cylinder	Maximum volume
		SPHERE/ Sphere	Maximum volume
		LINEAR/ Upright, linear (flat bottom)	Maximum volume
		CONICAL BOT/ Conical or pyramidal bottom	Maximum volume, dimension A
		PARABOLIC BOT/Parabolic bottom	Maximum volume, dimension A
		HALF SPHERE BOT/ Half-sphere bottom	Maximum volume, dimension A

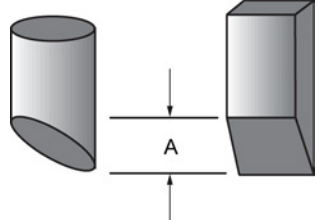
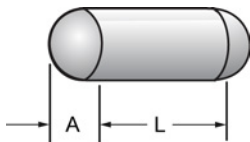
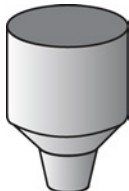
	Vessel Shape	LCD DISPLAY/ Description	Also required
		FLAT SLOPED BOT/ Flat sloped bottom	Maximum volume, dimension A
		PARABOLIC ENDS/ Parabolic end horizontal cylinder	Maximum volume, dimension A, dimension L
		LINEAR TABLE ^{a)} / Linearization table (level/volume breakpoints)	Maximum volume, tables 1-32 level and volume breakpoints

a) Linearization Table must be selected in order for level/volume values [see **Table 1-8 (2.7.2.)**] to be transferred.

Maximum Volume (2.7.1.2.)

The maximum volume of the vessel. Enter the vessel volume corresponding to High Calibration Point. For example, if your maximum vessel volume is 8000 L, enter a value of 8000. Volume units are defined by the user but are not explicitly stated or shown in the SITRANS LR250.

Values	Range: 0.0 to 99999 m
	Default: 100.0
Related Parameters	Low Calibration Pt. (2.3.1.) High Calibration Pt. (2.3.2.) Vessel Shape (2.7.1.1.)

Vessel Dimension A (2.7.1.3.)

The height of the vessel bottom when the bottom is conical, pyramidal, parabolic, spherical, or flat -sloped. If the vessel is horizontal with parabolic ends, the depth of the end. See **Vessel Shape (2.7.1.1.)** for an illustration.

Values	Range: 0.0 to 99.999 m
	Default: 0.0
Related Parameters	Units (2.2.1.) Vessel Shape (2.7.1.1.)

Vessel Dimension L (2.7.1.4.)

Length of the cylindrical section of a horizontal parabolic end vessel. See **Vessel Shape (2.7.1.1.)** for an illustration.

Values	Range: 0.0 to 99.99 m
	Default: 0.0
Related Parameters	Units (2.2.1.) Vessel Shape (2.7.1.1.)

Table 1-8 (2.7.2.)

Note

Linearization Table must be selected in **Vessel Shape (2.7.1.1.)** in order for level/volume values to be transferred.

If your vessel shape is more complex than any of the preconfigured shapes, you can define the shape as a series of segments. A value is assigned to each level breakpoint and a corresponding value is assigned to each volume breakpoint. Level values are defined in **Units (2.2.1.)**. Volume units are defined by the user but are not explicitly stated in the SITRANS LR250.

Level Values	Range: 0.0 to span
	Span = High Calibration Pt. (2.3.2.) - Low Calibration Pt. (2.3.1.)
	Default: 0.0
Volume Values	Range: 0.0 to Maximum Volume (2.7.1.2.)
	Default: 0.0

Enter up to 32 level breakpoints, where the corresponding volume is known. The values corresponding to 100% and 0% levels must be entered. The breakpoints can be ordered from top to bottom, or the reverse.

Breakpoints are grouped into four tables: Table 1-8, Table 9-16, Table 17-24, and Table 25-32.

Entering breakpoints via the handheld programmer:

1. The default unit for level values is **m**: to change it navigate to **Setup (2.) > Sensor (2.2.) > Units(2.2.1.)**, and select the desired unit.
2. Navigate to **Setup (2.) > Linearization (2.7.) > Maximum Volume (2.7.1.2.)**, and enter the value.
3. Go to the appropriate table for the particular breakpoint you wish to adjust: for example, go to Table 1-8 for breakpoint 1.
4. Under Table 1-8, go to **Level 1 (2.7.2.1.)** to enter the level value for the breakpoint 1.
5. Under Table 1-8, go to **Volume 1 (2.7.2.2.)** to enter the volume value for the breakpoint 1.
6. Repeat steps 3 to 5, until values have been entered for all required breakpoints.

Level 1 (2.7.2.1.)

1. Press **RIGHT arrow** to open Edit mode.
2. Enter level value and press **RIGHT arrow** to except it.
3. Press **DOWN arrow** to move to corresponding volume breakpoint.

Volume 1 (2.7.2.2.)

1. Press **RIGHT arrow** to open Edit mode.
2. Enter volume value and press **RIGHT arrow** to accept it.
3. Press **DOWN arrow** to move to next level breakpoint.

Example (values are for example purposes only)

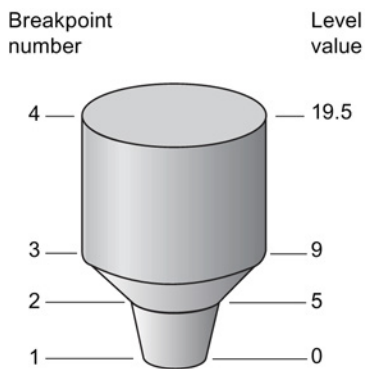

Breakpoint Number	Level value (m)	Volume value (l)
1	0	0
2	5	500
3	9	3000
4	19.5	8000

Table 9-16 (2.7.3.)

Table 17-24 (2.7.4.)

Table 25-32 (2.7.5.)

Signal Processing (2.8.)

Note

Default settings in the parameter tables are indicated with an asterisk (*) unless explicitly stated.

Near Range (2.8.1.)

The range in front of the device (measured from the sensor reference point) within which any echoes will be ignored. This is sometimes referred to as blanking or a dead zone. The factory setting is 50 mm (2") past the end of the antenna, and the default is dependent on the antenna type and process connection. [See Dimension drawings (Page 209) for antenna heights.]

Values	Range: 0 to 20 m (0 to 65.6 ft)
	Default depends on antenna type and process connection:
Related parameters	Units (2.2.1.)

Far Range (2.8.2.)

Note

Far Range can extend beyond the bottom of the vessel.

Allows the material level to drop below Low Calibration Point without generating a Loss of Echo (LOE) state. See **Sensor Mode (2.2.2.)** for an illustration.

Values	Range: Min. = Low Calibration Pt.
	Max. = 23 m (75.45 ft)
	Default: Value for Low Calibration Pt. + 1 m (3.28 ft)
Related parameters	Units (2.2.1.)

Use this feature if the measured surface can drop below the Low Cal. Point in normal operation.

Propogation Factor (2.8.3.)

Note

- When operating in a stillpipe, values for **CLEF Range (2.8.4.4.)**, and for the propagation factor, should be set according to the pipe size. See the table below.
- For reliable results the antenna size must be close to the pipe size.

Compensates for the change in microwave velocity due to propagation within a metal stillpipe instead of in free space.

Values	Range	0.3 to 1.0 depending on pipe size		
	Default	1.0000		
Nominal Pipe Size ^{a)}	40 mm (1.5")	50 mm (2")	80 mm (3")	100 mm (4")
Propagation Factor	0.9844	0.988	0.9935	0.9965
CLEF Range (2.8.4.4.) settings	Low calibration point - 700 mm (2.29 ft) ^{b)}	Low calibration point - 700 mm (2.29 ft) ^{b)}	Low calibration point - 1000 mm (3.28 ft) ^{b)}	Low calibration point - 1000 mm (3.28 ft) ^{b)}

a) Since pipe dimensions may vary slightly, the propagation factor may also vary.

b) CLEF range covers the whole measurement range except first 700 or 1000 mm from unit reference point (see A in graphic below)

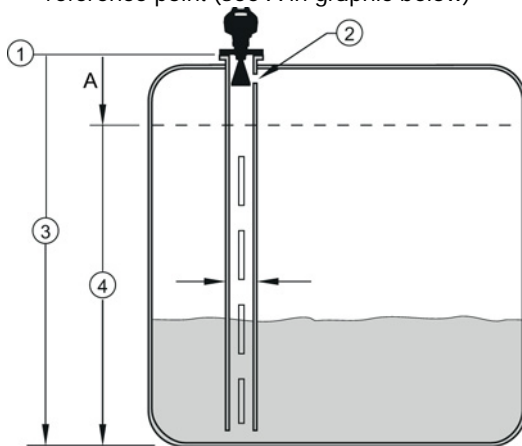

① sensor reference point

② air gap

A 700 or 1000 mm

③ low calibration point

④ CLEF range 2.8.4.4.

Note

Flanged encapsulated antenna

For Flanged encapsulated antenna (7ML5432) match the process connection size to the pipe diameter whenever possible (for example, mount a DN80/3" flange on DN80/3" pipe).

Echo Select (2.8.4.)

Algorithm (2.8.4.1.)

Selects the algorithm to be applied to the echo profile to extract the true echo.

Options	*	tF	True First echo
		L	Largest echo
		BLF	Best of Largest and First echo

Position Detect (2.8.4.2.)

Defines where on the echo the distance measurement is determined.

Options		Center
	*	Hybrid (Center and CLEF)
		CLEF (Constrained Leading Edge Fit)
Related parameters		CLEF Range (2.8.4.4.)

If the vessel bottom is being reported as the level instead of the actual material level (at low level conditions), or if the dielectric constant of the liquid to be monitored is less than 3, we recommend setting Position Detect to Hybrid and **CLEF Range (2.8.4.4.)** to 0.5 m (1.64 ft).

Echo Threshold (2.8.4.3.)

Sets the minimum echo confidence that the echo must meet in order to prevent a Loss of Echo condition and the expiration of the Fail-safe (LOE) timer. When **Confidence (2.8.6.1.)** exceeds **Echo Threshold (2.8.4.3.)**, the echo is accepted as a valid echo and is evaluated.

Values	Range: 0 to 99
	Default: 5
Related Parameters	LOE Timer (2.5.2.)

CLEF Range (2.8.4.4.)

Note

CLEF Range is referenced from Far range.

The CLEF algorithm is used mainly to allow correct level reporting for low dK materials which may otherwise cause an incorrect reading in an empty or almost empty vessel.

It is used from Low Calibration Point (process empty level) up to the level defined by CLEF Range (see illustration below). Above that point the Center algorithm is used. For more detail see CLEF Range (Page 258).

Values	Range: 0 to 20 m (0 to 65.6 ft)
	Default: 0.0 m
Related parameters	Position Detect (2.8.4.2.)

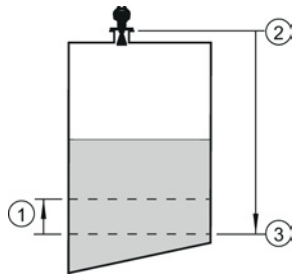

- ① CLEF Range
- ② Sensor reference point
- ③ Low Calibration Point (process empty level)

In applications with low dK materials we recommend setting CLEF Range to 0.5 m (1.64 ft) and **Position Detect (2.8.4.2.)** to Hybrid.

Sampling (2.8.5.)

Provides a method of checking the reliability of a new echo before accepting it as the valid reading, based on numbers of samples above or below the currently selected echo.

Echo Lock (2.8.5.1.)

Note

Ensure the agitator is always running while SITRANS LR250 is monitoring the vessel, to avoid stationary blade detection.

Selects the measurement verification process.

Options		Lock Off
		Maximum Verification (not recommended for radar)
	*	Material Agitator
		Total Lock (not recommended for radar)
Related parameters		Fill Rate per Minute (2.4.2.) Empty rate per Minute (2.4.3.) Sampling Up (2.8.5.2.) Sampling Down (2.8.5.3.)

For radar applications, Material Agitator is the most often-used setting, to avoid agitator blade detection.

Sampling Up (2.8.5.2.)

Specifies the number of consecutive echoes that must appear above the echo currently selected, before the measurement is accepted as valid.

Values	Range: 1 to 50
	Default: 5

Sampling Down (2.8.5.3.)

Specifies the number of consecutive echoes that must appear below the echo currently selected, before the measurement is accepted as valid.

Values	Range: 1 to 50
	Default: 2

Echo Quality (2.8.6.)

Confidence (2.8.6.1.)

Indicates echo reliability: higher values represent better echo quality. The display shows the echo confidence of the last measurement. **Echo Threshold (2.8.4.3.)** defines the minimum criterion for echo confidence.

Values (view only)	0 to 99	
	----	Shot not used
Related Parameters	Echo Threshold (2.8.4.3.)	

Open the menu **Device – Echo Profile Utilities** and click on the tab **Echo Profile**.

Echo Strength (2.8.6.2.)

Displays the absolute strength (in dB above 1 μ V rms) of the echo selected as the measurement echo.

Values (view only)	-20 to 99	
	----	Shot not used

Open the menu **Device – Echo Profile Utilities** and click on the tab **Echo Profile**.

Noise Average (2.8.6.3.)

Displays the average ambient noise (in dB above 1 μ V rms) of a noise profile. Noise level is a combination of transient noise and receiving circuitry. After a measurement, the values from the previous noise shot will be displayed.

TVT Setup (2.8.7.)

Note

Default settings in the parameter tables are indicated with an asterisk (*) unless explicitly stated.

Auto False Echo Suppression (2.8.7.1.)

Used together with **Auto False Echo Suppression Range (2.8.7.2.)** to screen out false echoes in a vessel with known obstructions. A 'learned TVT' (time varying threshold) replaces the default TVT over a specified range. See Auto False Echo Suppression (Page 259) for a more detailed explanation.

Note

- Make sure material level is below all known obstructions when Auto False Echo Suppression is used to learn the echo profile. (An empty or almost empty vessel is recommended.)
 - Note the distance to material level when Auto False Echo learns the environment. Set Auto False Echo Suppression Range to a shorter distance to avoid the material echo being screened out.
 - Set Auto False Echo Suppression and Auto False Echo Suppression Range during startup, if possible.
 - If the vessel contains an agitator it should be running.
 - Before adjusting these parameters, rotate the instrument for best signal (lower false-echo amplitude).
-

Before Auto False Echo Suppression

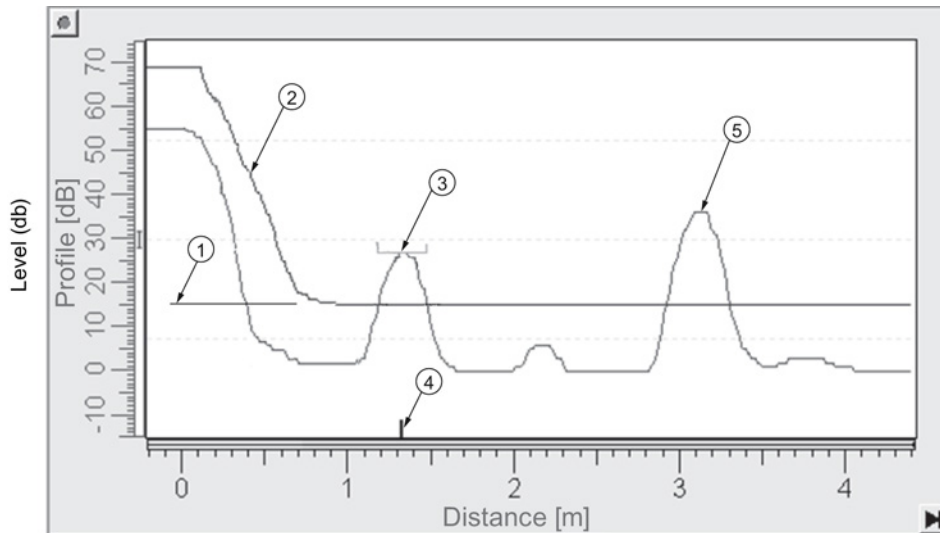

- ① TVT Hover Level
- ② default TVT
- ③ false echo
- ④ echo marker
- ⑤ material level

1. Determine Auto False Echo Suppression Range. Measure the actual distance from the sensor reference point to the material surface using a rope or tape measure.
2. Subtract 0.5 m (20") from this distance, and use the resulting value.
3. Go to **Auto False Echo Suppression Range (2.8.7.2.)** and enter the value calculated in step 2.
4. Go to **Auto False Echo Suppression (2.8.7.1.)** and press RIGHT arrow to open Edit Mode.
5. Select **Learn**. The device will automatically revert to **On** (Use Learned TVT) after a few seconds.

After Auto False Echo Suppression

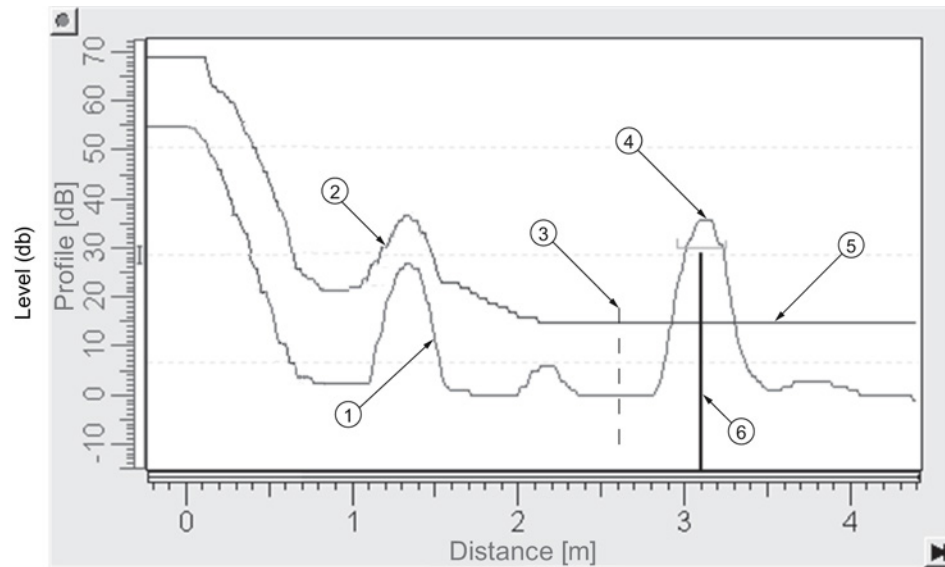

- ① false echo
- ② learned TVT
- ③ Auto False Echo Suppression Range
- ④ material level
- ⑤ default TVT
- ⑥ echo marker

To set Auto False Echo Suppression via SIMATIC PDM:

Open the menu **Device – Echo Profile Utilities** and click on the tab **Auto False Echo Suppression**. For more detailed instructions see Auto False Echo Suppression via SIMATIC PDM (Page 92).

To set Auto False Echo Suppression via the handheld programmer:

Options		OFF	Default TVT will be used.
	*	ON	'Learned' TVT will be used.
		LEARN	'Learn' the TVT ^{a)} .

^{a)} The learned TVT takes effect only at the next measurement.

Auto False Echo Suppression Range (2.8.7.2.)

Note

Changes take effect only at the next measurement. "Master reset" does not clear the learned/stored TVT, select "Off" to turn it off or "learn" for a new TVT. See **Master Reset (4.1.)**

Specifies the range within which Learned TVT is used [see **Auto False Echo Suppression (2.8.7.1.)** for more detail].

Values	Range: 0.00 to 20.00 m
	Default: 1.00 m
Related parameters	Units (2.2.1.)

1. Calculate range according to **Auto False Echo Suppression (2.8.7.1.)** steps 1 and 2.
2. Press **RIGHT arrow** to open Edit mode.
3. Enter the new value and press **RIGHT arrow** to accept it.
4. Set **Auto False Echo Suppression (2.8.7.1.)**.

Hover Level (2.8.7.3.)

Note

Changes take effect only at the next measurement.

Defines how high the TVT (Time Varying Threshold) is placed above the noise floor of the echo profile, as a percentage of the difference between the peak of the largest echo in the profile and the noise floor. See **Auto False Echo Suppression (2.8.7.1.)** for an illustration.

Values	Range: 0 to 100%
	Default: 40%

When the device is located in the center of the vessel, the TVT hover level may be lowered to increase the confidence level of the largest echo.

Shaper Mode (2.8.7.4.)

Enables/disables the TVT shaper.

Options		ON
	*	OFF

TVT shaper (2.8.8.)

Note

- The range is –100 to 100 bits. With 2 bits per dB this gives a range of –50 to 50 dB.
- **Shaper Mode (2.8.7.4.)** must be turned ON in order for TVT shaper points to be transferred.

Adjusts the TVT (Time Varying Threshold) at a specified range (breakpoint on the TVT). This allows you to reshape the TVT to avoid unwanted echoes. There are 40 breakpoints arranged in 5 groups. (We recommend using SIMATIC PDM to access this feature.)

To use TVT shaper via SIMATIC PDM:

1. Go to **Level Meter > Setup > Signal Processing > TVT setup > Shaper Mode** and select **On**.
2. Open the menu **Device – Echo Profile Utilities** and click on **TVT Shaper**. For more detail see TVT shaper via SIMATIC PDM (Page 91).

To use TVT shaper via LUI (local user interface):

1. Go to **Shaper Mode (2.8.7.4.)** and select **On**.
2. Go to **Breakpoint 1-9 (2.8.8.1.)**.
3. Open Shaper 1 and enter the TVT Offset value (between –50 and 50).
4. Go to the next Shaper point and repeat steps 3 and 4 until all desired breakpoint values have been entered.

Breakpoint 1-9 (2.8.8.1.)

Values	Range: –50 to 50 dB
	Default: 0 dB

Breakpoint 10-18 (2.8.8.2.)

Values	Range: –50 to 50 dB
	Default: 0 dB

Breakpoint 19-27 (2.8.8.3.)

Values	Range: –50 to 50 dB
	Default: 0 dB

Breakpoint 28-36 (2.8.8.4.)

Values	Range: -50 to 50 dB
	Default: 0 dB

Breakpoint 37-40 (2.8.8.5.)

Values	Range: -50 to 50 dB
	Default: 0 dB

Measured Values (2.8.9.)

Read only. Allows you to view measured values for diagnostic purposes.

To access measured values via SIMATIC PDM:

Open the menu **View – Process Variables**.

Level Measurement (2.8.9.1.)

The value for level.

Space Measurement (2.8.9.2.)

The value for space.

Distance Measurement (2.8.9.3.)

The value for distance.

Volume Measurement (2.8.9.4.)

The value for volume.

Diagnostics (3.)

Echo Profile (3.1.)

Allows you to request the current echo profile either locally via the handheld programmer, or remotely via SIMATIC PDM, or AMS Device Manager. [For more detail see Echo Processing (Page 254)].

To request a profile via SIMATIC PDM:

Open the menu **Device – Echo Profile Utilities**. [For more detail see Echo Profile Utilities via SIMATIC PDM (Page 88)].

To request a profile via the handheld programmer:

1. In **PROGRAM** mode, navigate to **Level Meter > Diagnostics (3.) > Echo Profile (3.1.)**
2. Press **RIGHT arrow** to request a profile.

[For more detail see Requesting an Echo Profile (Page 69)].

Electronics Temperature (3.2.)

Current Internal Temperature (3.2.1.)

Read only. Displays (in degrees C) the current temperature on the circuit board recorded by the internal electronics.

For access via SIMATIC PDM open the menu **View – Process Variables** and check the field **Electronics Temperature**.

Highest Value (3.2.2.)

Read only. Displays (in degrees C) the maximum temperature recorded by the internal electronics. The high and low values are maintained over a power cycle.

Via SIMATIC PDM navigate to **Maintenance and Diagnostics > Electronics Temperature**.

Lowest Value (3.2.3.)

Read only. Displays (in degrees C) the minimum temperature recorded by the internal electronics. The high and low values are maintained over a power cycle.

Via SIMATIC PDM navigate to **Maintenance and Diagnostics > Electronics Temperature**.

Service (4.)

Note

Default settings in the parameter tables are indicated with an asterisk (*) unless explicitly stated.

Master Reset (4.1.)

Note

Following a reset to **Factory Defaults**, complete reprogramming is required.

Resets all parameter to factory defaults, with the following exceptions:

- **Device Address (5.1.)** remains unchanged if the reset command is sent remotely (via AMS, PDM, DTM, FC375) but is reset to 0 if the reset command is sent via LUI.
- **Write Protect (6.2.1.)** and **PIN to Unlock (6.2.2.)** values are not reset.
- **Auto False Echo Suppression (2.8.7.1.)** learned TVT and **Auto False Echo Suppression Range (2.8.7.2.)** are not lost.

Options	*	Idle or Done (Return to previous menu)
		Factory Defaults

To perform a reset to factory defaults via SIMATIC PDM, open the menu **Device – Master Reset** and click on **Factory Defaults**.

Remaining Device Lifetime (4.2.)

Note

- Default settings in the parameter tables are indicated with an asterisk (*) unless explicitly stated.
- Four sets of parameters allow you to monitor the Device/Sensor Lifetimes and set up Maintenance/Service schedules, based on operating hours instead of a calendar-based schedule. See also **Remaining Sensor Lifetime (4.3.)**, **Service Schedule (4.4.)**, and **Calibration Schedule (4.5.)**.
- Performing a reset to **Factory Defaults** will reset all the Maintenance Schedule parameters to their factory defaults.
- The device operates in years. To view Remaining Device Lifetime parameters in hours or days (via SIMATIC PDM only) see **Lifetime (Expected) (4.2.1.)**.

The device tracks itself based on operating hours and monitors its predicted lifetime. You can modify the expected device lifetime, set up schedules for maintenance reminders, and acknowledge them.

The maintenance warnings and reminders are available through HART communications. This information can be integrated into an Asset Management system. For optimal use, we recommend that you use SIMATIC PCS7 Asset Management Software in conjunction with SIMATIC PDM.

To access these parameters via SIMATIC PDM:

- Open the menu **Device – Maintenance** and select the **Remaining Device Lifetime** tab.
- After modifying values/units as required, click on **Write** to accept the change, and **Read** to view the effect of the change.
- Click on **Snooze** to add a year to the Total Expected Device Life.

Time Units

Options ^{a)}	Hours; days; years
	Default: years

^{a)} Selectable only via SIMATIC PDM.

Lifetime (Expected) (4.2.1.)

The screenshot shows the 'Maintenance - Sitrans' window with the 'Remaining Device Lifetime' tab selected. The window title is 'Maintenance - Sitrans'. The 'SIEMENS' logo is visible in the top left. A warning icon (exclamation mark in a square) is in the top right. The parameters are as follows:

Parameter	Value	Unit
Time Units	Years	Years
Lifetime (Expected)	10.000	Years
Time in Operation	0.000	Years
Remaining Lifetime	10.000	Years
Activation of Reminders	Off	
Reminder 1 before Lifetime (Required)	0.164	Years
Reminder 2 before Lifetime (Demanded)	0.019	Years

Buttons: Read, Write, Snooze for 1 year, OK, Cancel, Help.

Note

The device always operates in years. Changing the units affects only the parameter view of the Service Interval parameters in SIMATIC PDM.

User-configurable recommended time between product inspections.

Values	Units ^{a)} : hours, days, years
	Range: 0 to 20 years
	Default: 10 years

^{a)} Units are selectable only via SIMATIC PDM.

Time in Operation (4.2.2.)

Read only. The amount of time the device has been operating.

Remaining Lifetime (4.2.3.)

Read only. **Lifetime (Expected) (4.2.1.)** less **Time in Operation (4.2.2.)**.

Activation of Reminders (4.2.4.)

Note

To modify this parameter via SIMATIC PDM it must be accessed via the pull-down menu **Device – Maintenance**.

Allows you to enable a maintenance reminder.

Values	*	Timer OFF
		ON - no reminders checked
		ON - Reminder 1 (Maintenance Required) checked
		ON - Reminders 1 and 2 checked
		ON - Reminder 2 (Maintenance Demanded) checked

1. First set the values in **Reminder 1 before Lifetime (Required) (4.2.5.)**/ **Reminder 2 before Lifetime (Demanded) (4.2.6.)**.
2. Select the desired **Activation of Reminders** option.

Reminder 1 before Lifetime (Required) (4.2.5.)

If **Remaining Lifetime (4.2.3.)** is equal to or less than this value, the device generates a Maintenance Required reminder.

Values	Range: 0 to Lifetime (Expected) (4.2.1.)
	Default: 0.164 years

1. Modify values as required.
2. Set **Activation of Reminders (4.2.4.)** to the desired option.

Reminder 2 before Lifetime (Demanded) (4.2.6.)

If **Remaining Lifetime (4.2.3.)** is equal to or less than this value, the device generates a Maintenance Demanded reminder.

Values	Range: 0 to Lifetime (Expected) (4.2.1.)
	Default: 0.019 years

1. Modify values as required.
2. Set **Activation of Reminders (4.2.4.)** to the desired option.

Maintenance Status (4.2.7.)

Indicates which level of maintenance reminder is active.

In SIMATIC PDM, open the menu **View – Device Status**, click on the **Maintenance** tab, and check the **Device Lifetime Status** window.

Acknowledge Status (4.2.8.)

Indicates which level of maintenance reminder has been acknowledged.

In SIMATIC PDM, open the menu **View – Device Status**, click on the **Maintenance** tab, and check the **Device Lifetime Status** window.



Acknowledge (4.2.9.)

Acknowledges the current maintenance reminder.

To acknowledge a reminder via SIMATIC PDM:

1. Open the menu **View – Device Status** and click on the **Maintenance** tab.
2. In the **Device Lifetime** section, click on **Acknowledge Warnings**.

To acknowledge a reminder via the handheld programmer:

1. Press **RIGHT arrow**  twice to open parameter view and activate Edit Mode.
2. Press **RIGHT arrow**  to acknowledge the reminder.

Remaining Sensor Lifetime (4.3.)

Note

- Default settings in the parameter tables are indicated with an asterisk (*) unless explicitly stated.
- Four sets of parameters allow you to monitor the Device/Sensor Lifetimes and set up Maintenance/Service schedules, based on operating hours instead of a calendar-based schedule. See also **Remaining Device Lifetime (4.2.)**, **Service Schedule (4.4.)**, and **Calibration Schedule (4.5.)**.
- Performing a reset to Factory Defaults will reset all the Maintenance Schedule parameters to their factory defaults.
- The device operates in years. To view Remaining Sensor Lifetime parameters in hours or days (via SIMATIC PDM only) see **Lifetime Expected (4.3.1.)**.

The device monitors the predicted lifetime of the sensor (the components exposed to the vessel environment). You can modify the expected sensor lifetime, set up schedules for maintenance reminders, and acknowledge them.

To access these parameters via SIMATIC PDM:

- Open the menu **Device – Maintenance** and select the **Remaining Sensor Lifetime** tab.
- After modifying values/units as required, click on **Write** to accept the change, and **Read** to view the effect of the change.
- Click on **Snooze** to add a year to the Total Expected Sensor Life.
- Click on **Sensor Replaced** to restart the timer and clear any fault messages.

Time Units

Options ^{a)}	Hours; days; years
	Default: years

^{a)} Selectable only via SIMATIC PDM.

Lifetime (Expected) (4.3.1.)

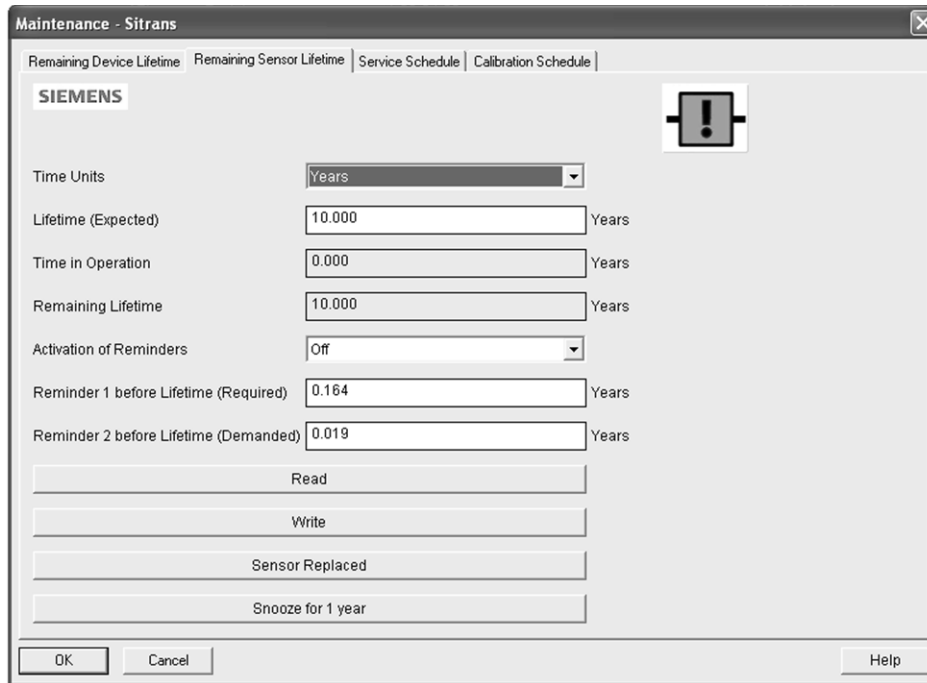

Note

The device always operates in years. Changing the units affects only the parameter view of Remaining Sensor Life parameters in SIMATIC PDM.

Allows you to override the factory default.

Values	Units ^{a)} : hours, days, years
	Range: 0 to 20 years
	Default: 10.00 years

^{a)} Units are selectable only via SIMATIC PDM.

Time in Operation (4.3.2.)

The amount of time the sensor has been operating. Can be reset to zero after performing a service or replacing the sensor.

To reset to zero:

- In SIMATIC PDM, open the menu **Device – Maintenance**, click on the **Remaining Sensor Lifetime** tab, and click on **Sensor Replaced** to restart the timer and clear any fault messages.
- Via the handheld programmer, manually reset **Time in Operation (4.3.2.)** to zero.

Remaining Lifetime (4.3.3.)

Read only. **Lifetime (Expected) (4.3.1.)** less **Time in Operation (4.3.2.)**.

Activation of Reminders (4.3.4.)

Note

To modify this parameter via SIMATIC PDM it must be accessed via the pull-down menu **Device – Maintenance**.

Allows you to enable a maintenance reminder.

Options		Reminder 1 (Maintenance Required)
		Reminder 2 (Maintenance Demanded)
		Reminders 1 and 2
	*	OFF

1. First set the values in **Reminder 1 before Lifetime (Required) (4.3.5.)**/**Reminder 2 before Lifetime (Demanded) (4.3.6.)**.
2. Select the desired **Activation of Reminders** option.

Reminder 1 before Lifetime (Required) (4.3.5.)

If **Remaining Lifetime (4.3.3.)** is equal to or less than this value, the device generates a **Maintenance Required** reminder.

Values	Range: 0 to Lifetime (Expected) (4.3.1.)
	Default: 0.164 years

1. Modify values as required.
2. Set **Activation of Reminders (4.3.4.)** to the desired option.

Reminder 2 before Lifetime (Demanded) (4.3.6.)

If **Remaining Lifetime (4.3.3.)** is equal to or less than this value, the device generates a **Maintenance Demanded** reminder.

Values	Range: 0 to Lifetime (Expected) (4.3.1.)
	Default: 0.019 years

1. Modify values as required.
2. Set **Activation of Reminders (4.3.4.)** to the desired option.

Maintenance Status (4.3.7.)

Indicates which level of maintenance reminder is active.

In SIMATIC PDM, open the menu **View – Device Status**, click on the **Maintenance** tab, and check the **Sensor Lifetime Status** window.

Acknowledge Status (4.3.8.)

Indicates which level of maintenance reminder has been acknowledged.

In SIMATIC PDM, open the menu **View – Device Status**, click on the **Maintenance** tab, and check the **Sensor Lifetime Status** window.



Acknowledge (4.3.9.)

Acknowledges the current maintenance reminder.

To acknowledge a reminder via SIMATIC PDM:

1. Open the menu **View – Device Status** and click on the **Maintenance** tab.
2. In the **Sensor Lifetime** section, click on **Acknowledge Warnings**.

To acknowledge a reminder via the handheld programmer:

1. Press **RIGHT arrow**  twice to open parameter view and activate **Edit Mode**.
2. Press **RIGHT arrow**  to acknowledge the reminder.

Service Schedule (4.4.)

Note

- Four sets of parameters allow you to monitor the Device/Sensor Lifetimes and set up Maintenance/Service schedules, based on operating hours instead of a calendar-based schedule. See also **Remaining Device Lifetime (4.2.)**, **Remaining Sensor Lifetime (4.3.)**, and **Calibration Schedule (4.5.)**.
- Performing a reset to **Factory Defaults** will reset all the Maintenance Schedule parameters to their factory defaults.
- The device operates in years. To view Service Interval parameters in hours or days (via SIMATIC PDM only) see **Service interval (4.4.1.)**.

The device tracks service intervals based on operating hours and monitors the predicted lifetime to the next service. You can modify the Total Service Interval, set schedules for maintenance reminders, and acknowledge them.

The maintenance warnings and reminders are communicated to the end user through status information. This information can be integrated into any Asset Management system. For optimal use, we recommend that you use SIMATIC PCS7 Asset Management Software in conjunction with SIMATIC PDM.

To access these parameters via SIMATIC PDM:

- Open the menu **Device – Maintenance** and select the **Service Schedule** tab.
- After modifying values/units as required, click on **Write** to accept the change, and **Read** to view the effect of the change.
- Click on **Service Performed** to restart the timer and clear any fault messages.

Time Units

Options ^{a)}	Hours; days; years
	Default: years

^{a)} Selectable only via SIMATIC PDM.

Service Interval (4.4.1.)

The screenshot shows the 'Maintenance - Sitrans' window with the 'Service Schedule' tab selected. The parameters are as follows:

Parameter	Value	Unit
Time Units	Years	
Service Interval	1.000	Years
Time Since Last Service	0.000	Years
Time Until Next Service	1.000	Years
Activation of Reminders	Timer Off	
Reminder 1 before Service (Required)	0.164	Years
Reminder 2 before Service (Demanded)	0.019	Years

Buttons: Read, Write, Service Performed, OK, Cancel, Help.

Note

The device always operates in years. Changing the units affects only the parameter view of the Service Interval parameters in SIMATIC PDM.

User-configurable recommended time between product inspections.

Values	Units ^{a)} : hours, days, years
	Range: 0 to 20 years
	Default: 1.0 year

^{a)} Units are selectable only via SIMATIC PDM.

Time Since Last Service (4.4.2.)

Time elapsed since last service. Can be reset to zero after performing a service.

To reset to zero:

- In SIMATIC PDM, open the menu **Device – Maintenance**, click on the **Service Schedule** tab, and click on **Service Performed** to restart the timer and clear any fault messages.
- Via the handheld programmer, manually reset **Time since Last Service (4.4.2.)** to zero.

Time Until Next Service (4.4.3.)

Read only. **Service Interval (4.4.1.)** less **Time Since Last Service (4.4.2.)**.

Activation of Reminders (4.4.4.)**Note**

To modify this parameter via SIMATIC PDM it must be accessed via the pull-down menu **Device – Maintenance**.

Allows you to enable a maintenance reminder.

Options	*	Timer OFF
		ON - no reminders checked
		ON - Reminder 1 (Maintenance Required) checked
		ON - Reminders 1 and 2 checked
		ON - Reminder 2 (Maintenance Demanded) checked

1. First set the values in **Reminder 1 before Service (Required) (4.4.5.)**/**Reminder 2 before Service (Demanded) (4.4.6.)**.
2. Select the desired **Reminder Activation** option.

Reminder 1 before Service (Required) (4.4.5.)

If **Time Until Next Service (4.4.3.)** is equal to or less than this value, the device generates a **Maintenance Required** reminder.

Values	Range: 0 to Service Interval (4.4.1.)
	Default: 0.164 years

1. Modify values as required.
2. Set **Activation of Reminders (4.4.4.)** to the desired option.

Reminder 2 before Service (Demanded) (4.4.6.)

If **Time Until Next Service (4.4.3.)** is equal to or less than this value, the device generates a **Maintenance Required** reminder.

Values	Range: 0 to Service Interval (4.4.1.)
	Default: 0.019 years

1. Modify values as required
2. Set **Activation of Reminders (4.4.4.)** to the desired option.

Maintenance Status (4.4.7.)

Indicates which level of maintenance reminder is active.

Open the menu **View – Device Status**, click on the **Maintenance** tab and check the **Service Schedule Status** window.

Acknowledge Status (4.4.8.)

Indicates which level of maintenance reminder has been acknowledged.

Open the menu **View – Device Status**, click on the **Maintenance** tab and check the **Service Schedule Status** window.



Acknowledge (4.4.9.)

Acknowledges the current maintenance reminder.

To acknowledge a reminder via SIMATIC PDM:

1. Open the menu **View – Device Status** and click on the **Maintenance** tab.
2. In the **Service Schedule Status** section, click on **Acknowledge Warnings**.

To acknowledge a reminder via the handheld programmer:

1. Press **RIGHT**  **arrow** twice to open parameter view and activate **Edit Mode**.
2. Press **RIGHT**  **arrow** to acknowledge the reminder.

Calibration Schedule (4.5.)

Note

- Default settings in the parameter tables are indicated with an asterisk (*) unless explicitly stated.
- Four sets of parameters allow you to monitor the Device/Sensor Lifetimes and set up Maintenance/Service schedules, based on operating hours instead of a calendar-based schedule. See also **Remaining Device Lifetime (4.2.)**, **Remaining Sensor Lifetime (4.3.)**, and **Service Schedule (4.4.)**.
- Performing a reset to **Factory Defaults** will reset all the Maintenance Schedule parameters to their factory defaults.
- The device operates in years. To view Calibration Interval parameters in hours or days (via SIMATIC PDM only) see **Calibration Interval (4.5.1.)**.

The device tracks calibration intervals based on operating hours and monitors the predicted lifetime to the next calibration. You can modify the Total Calibration Interval, set schedules for maintenance reminders, and acknowledge them.

To access these parameters via SIMATIC PDM:

- Open the menu **Device – Maintenance** and select the **Calibration Schedule** tab.
- After modifying values/units as required, click on **Write** to accept the change, and **Read** to view the effect of the change.
- Click on **Calibration Performed** to restart the timer and clear any fault messages.

Time Units

Options ^{a)}	Hours; days; years
	Default: years

^{a)} Selectable only via SIMATIC PDM.

Calibration Interval (4.5.1.)

The screenshot shows the 'Maintenance - Sitrans' window with the 'Calibration Schedule' tab selected. The window title is 'Maintenance - Sitrans'. The main area is labeled 'SIEMENS'. There are four tabs: 'Remaining Device Lifetime', 'Remaining Sensor Lifetime', 'Service Schedule', and 'Calibration Schedule'. A warning icon is visible in the top right corner. The parameters are as follows:

Time Units	Years	
Calibration Interval	1.000	Years
Time Since Last Calibration	0.000	Years
Time Until Next Calibration	1.000	Years
Activation of Reminders	Timer Off	
Reminder 1 before Calibration (Required)	0.164	Years
Reminder 2 before Calibration (Demanded)	0.019	Years
Read		
Write		
Calibration Performed		

At the bottom, there are buttons for 'OK', 'Cancel', and 'Help'.

Note

The device always operates in years. Changing the units affects only the parameter view of Remaining Sensor Life parameters in SIMATIC PDM.

User-configurable recommended time between product calibrations.

Values	Units ^{a)} : hours, days, years
	Range: 0 to 20 years
	Default: 1.0 year

^{a)} Units are selectable only via SIMATIC PDM.

Time Since Last Calibration (4.5.2.)

Time elapsed since last calibration. Can be reset to zero after performing a calibration.

To reset to zero:

- In SIMATIC PDM, open the menu **Device – Maintenance**, click on the **Calibration Schedule** tab, and click on **Calibration Performed** to restart the timer and clear any fault messages.
- Via the handheld programmer, manually reset **Time Since Last Calibration (4.5.2.)** to zero.

Time Until Next Calibration (4.5.3.)

Read only. **Calibration Interval (4.5.1.)** less **Time Since Last Calibration (4.5.2.)**.

Activation of Reminders (4.5.4.)

Note

To modify this parameter via SIMATIC PDM it must be accessed via the pull-down menu Device – Maintenance.

Allows you to enable a maintenance reminder.

Options		Timer OFF
		ON - no reminders checked
		ON - Reminder 1 (Maintenance Required) checked
	*	ON - Reminders 1 and 2 checked
		ON—Reminder 2 (Maintenance Demanded) checked

1. First set the values in **Reminder 1 before Calibration (Required) (4.5.5.)**/**Reminder 2 before Calibration (Demanded) (4.5.6.)**.
2. Select the desired **Activation of Reminders** option.

Reminder 1 before Calibration (Required) (4.5.5.)

If **Time Until Next Calibration (4.5.3.)** is equal to or less than this value, the device generates a **Maintenance Required** reminder.

Values	Range: 0 to Calibration Interval (4.5.1.)
	Default: 0.164 years

1. Modify values as required.
2. Set **Activation of Reminders (4.5.4.)** to the desired option.

Reminder 2 before Calibration (Demanded) (4.5.6.)

If **Time Until Next Calibration (4.5.3.)** is equal to or less than this value, the device generates a **Maintenance Demanded** reminder.

Values	Range: 0 to Calibration Interval (4.5.1.)
	Default: 0.164 years

1. Modify values as required.
2. Set Activation of Reminders (4.5.4.) to the desired option.

Maintenance Status (4.5.7.)

Indicates which level of maintenance reminder is active.

In SIMATIC PDM, open the menu **View – Device Status**, click on the **Maintenance** tab and check the **Calibration Schedule Status** window.

Acknowledge Status (4.5.8.)

Indicates which level of maintenance reminder has been acknowledged.

In SIMATIC PDM, open the menu **View – Device Status**, click on the **Maintenance** tab and check the **Calibration Schedule Status** window.



Acknowledge (4.5.9.)

Acknowledges the current maintenance reminder.

To acknowledge a reminder via SIMATIC PDM:

1. Open the menu **View – Device Status** and click on the **Maintenance** tab.
2. In the **Service Schedule Status** section, click on **Acknowledge Warnings**.

To acknowledge a reminder via the handheld programmer:

1. Press **RIGHT**  **arrow** twice to open parameter view and activate **Edit Mode**.
2. Press **RIGHT**  **arrow** to acknowledge the reminder.

Manufacture Date (4.6.)

Read only. The date of manufacture of the SITRANS LR250 (yy mm dd).

Powered Hours (4.7.)

Read only. Displays the number of hours the unit has been powered up since manufacture.

In SIMATIC PDM, open the menu **Device – Wear**.

Power-on Resets (4.8.)

Read only. The number of power cycles that have occurred since manufacture.

In SIMATIC PDM, open the menu **Device – Wear**.

LCD Fast Mode (4.9.)

Note

- LCD Fast Mode takes effect only after 30 minutes of inactivity. (Each time the device is powered up, a further 30 minutes of inactivity is required.)
- LCD Fast Mode affects Measurement mode only; it has no effect on Navigation mode.

Enables a faster rate of measurement from the device by disabling most of the display area. Only the bar graph will be refreshed when LCD Fast Mode is set to ON.

Values	ON or OFF
	Default: OFF

LCD Contrast (4.10.)

The factory setting is for optimum visibility at room temperature and in average light conditions. Extremes of temperature will lessen the contrast.

Values	Range: 0 (High contrast) to 20 (Low contrast) . Default: 10
--------	---

Adjust the value to improve visibility at room temperature and in average light conditions. Change the value in small steps to ensure you can continue to read the display.

Secondary Value (4.11.)

Use the secondary value to capture the menu navigation path to any viewable parameter. Once the navigation path is stored, the value of that parameter will be displayed in **Measurement** mode as the secondary value.

While in Parameter view of the current parameter, press the decimal point key. This stores the path to the current parameter in the Secondary Value, and displays the value for that parameter on the LCD display when in **Measurement** mode. See The LCD Display (Page 55) for an illustration.

Memory Test (4.12.)

Allows verification of the RAM, EEPROM, and Flash memory of the SITRANS LR250.

LCD Display	IDLE	No test in progress.
	BUSY	Test in progress.
	PASS	Memory test successful.
	FAIL	Test failed.
	Err1	Test returned unexpected results.
	P Oxcafe	Test passed with result data.
	F Oxcafe	Test failed with result data.
Handheld programmer entry		Any numeric key from 1 to 9 activates test.

- Press **RIGHT**  **arrow** to edit then press any numeric key from 1 to 9 to activate the test.
- The reading will display BUS and then the test result text.

Communication (5.)

Note

Default settings in the parameter tables are indicated with an asterisk (*) unless explicitly stated.

Device Address (5.1.)

Sets the device address or poll ID on a HART network. Any address other than 0 will cause the output current to be a fixed value, and the current will not indicate the reading.

Values	Range: 0 to 15
	Default: 0

To set Device Address via SIMATIC PDM:

- Open the project in **Process Device Network View** then right-click on the device.
- Go to **Object Properties > Connection** to access the field **Short Address**.

Security (6.)

Note

Default settings in the parameter tables are indicated with an asterisk (*) unless explicitly stated.

Remote Access (6.1.)

Access Control (6.1.1.)

Note

If access control is changed to limit remote access, it can only be reset via the handheld programmer.

Enables/disables the read/write access to parameters via remote communications.

Options		Read only	No changes are permitted via remote communications.
	*	Read Write	Changes are permitted.
		Restricted	Sets the status to Read only, with the potential for another HART device to change this parameter only, via remote communications.

Local Access (6.2.)

Write Protect (6.2.1.)

Note

This lock affects only the handheld programmer. A remote master can change configuration if **Access Control (6.1.1.)** is set to allow this.

Prevents any changes to parameters via the handheld programmer.

Options		Range: 0 to 9999	
	*	Unlock value [stored in PIN to Unlock (6.2.2.)]	Lock Off
		Any other value	Lock On

- To turn Lock On, key in any value other than the Unlock Value stored in **PIN to Unlock (6.2.2.)**.
- To turn Lock Off, key in the Unlock Value stored in **PIN to Unlock (6.2.2.)**.

PIN to Unlock (6.2.2.)

Note

- Do not lose your Unlock Value: it cannot be displayed once **Write Protect (6.2.1.)** has been set to a different value.
 - Valid only for operation via the handheld programmer.
 - A reset to **Factory Defaults** will not restore the unlock value at time of shipping.
-

Stores the value to be entered in **Write Protect (6.2.1.)** to unlock programming. If **Write Protect (6.2.1.)** is set to a different value, **PIN to Unlock (6.2.2.)** does not display the Unlock value.

Handheld Programmer Values	Range: 0 to 9999		
	Value when shipped: 1954. Not restored by a reset to Factory Defaults.		
	----	Display when Lock is on	

Language (7.)

Selects the language to be used on the LCD.

Options	*	English
		Deutsch
		Français
		Español

8.1 Alphabetical parameter list

Note

For a detailed list of parameters see Parameter Reference (Page 127). Maintenance Parameters are not listed below. See **Remaining Device Lifetime (4.2.)**, **Remaining Sensor Lifetime (4.3.)**, **Service Schedule (4.4.)** and **Calibration Schedule (4.5.)** for those parameters.

20 mA Setpoint (2.6.3.)
4 mA Setpoint (2.6.2.)
Access Control (6.1.1.)
Algorithm (2.8.4.1.)
Analog Output Scaling (2.6.)
Auto False Echo Suppression (2.8.7.1.)
Auto False Echo Suppression Range (2.8.7.2.)
Breakpoint 1-9 (2.8.8.1.)
Breakpoint 10-18 (2.8.8.2.)
Breakpoint 19-27 (2.8.8.3.)
Breakpoint 28-36 (2.8.8.4.)
Breakpoint 37-40 (2.8.8.5.)
Calibration (2.3.)
CLEF Range (2.8.4.4.)
Communication (5.)
Confidence (2.8.6.1.)
Current Internal Temperature (3.2.1.)
Current Output Function (2.6.1.)
Damping Filter (2.2.4.)
Device (2.1.)
Device Address (5.1.)
Diagnostics (3.)
Distance Measurement (2.8.9.3.)
Echo Lock (2.8.5.1.)
Echo Profile (3.1.)
Echo Quality (2.8.6.)

Echo Select (2.8.4.)
Echo Strength (2.8.6.2.)
Echo Threshold (2.8.4.3.)
Electronics Temperature (3.2.)
Empty Rate per Minute (2.4.3.)
Fail-safe (2.5.)
Fail-Safe mA Value (2.5.3.)
Far Range (2.8.2.)
Fill Rate per Minute (2.4.2.)
Firmware Revision (2.1.2.)
Hardware Revision (2.1.1.)
High Calibration Pt. (2.3.2.)
Highest value (3.2.2.)
Hover Level (2.8.7.3.)
Language (7.)
LCD Contrast (4.10.)
LCD Fast Mode (4.9.)
Level 1 (2.7.2.1.)
Level Measurement (2.8.9.1.)
Linearization (2.7.)
Loader Revision (2.1.3.)
Local Access (6.2.)
LOE Timer (2.5.2.)
Low Calibration Pt. (2.3.1.)
Lowest value (3.2.3.)
mA Output Value (2.6.6.)
Manufacture Date (4.6.)
Master Reset (4.1.)
Material (2.2.3.)
Material Level (2.5.1.)
Maximum mA limit (2.6.5.)
Maximum Volume (2.7.1.2.)
Measured Values (2.8.9.)

Memory Test (4.12.)
Menu Timeout (2.1.5.)
Minimum mA limit (2.6.4.)
Near Range (2.8.1.)
Noise Average (2.8.6.3.)
Order Option (2.1.4.)
PIN to Unlock (6.2.2.)
Position Detect (2.8.4.2.)
Power-on Resets (4.8.)
Powered Hours (4.7.)
Propagation Factor (2.8.3.)
Quick Start (1.)
Quick Start Wizard (1.1.)
Rate (2.4.)
Remote Access (6.1.)
Response Rate (2.4.1.)
Sampling (2.8.5.)
Sampling Down (2.8.5.3.)
Sampling Up (2.8.5.2.)
Shaper Mode (2.8.7.4.)
Signal Processing (2.8.)
Secondary Value (4.11.)
Security (6.)
Sensor (2.2.)
Sensor Mode (2.2.2.)
Sensor Offset (2.3.3.)
Service (4.)
Setup (2.)
Space Measurement (2.8.9.2.)
Table 1-8 (2.7.2.)
Table 9-16 (2.7.3.)
Table 17-24 (2.7.4.)

Table 25-32 (2.7.5.)
TVT Setup (2.8.7.)
TVT Shaper (2.8.8.)
Units (2.2.1.)
Vessel Dimension A (2.7.1.3.)
Vessel Dimension L (2.7.1.4.)
Vessel Shape (2.7.1.1.)
Volume (2.7.1.)
Volume 1 (2.7.2.2.)
Volume Measurement (2.8.9.4.)
Write Protect (6.2.1.)