



Service and maintenance

9.1 Basic safety information

 WARNING
Impermissible repair of the device <ul style="list-style-type: none">• Repair must be carried out by Siemens authorized personnel only.

 CAUTION
Releasing key lock <p>Improper modification of parameters could influence process safety.</p> <ul style="list-style-type: none">• Make sure that only authorized personnel may cancel the key locking of devices for safety-related applications.

9.2 Cleaning

The radar device requires no cleaning under normal operating conditions.

Under severe operating conditions, the antenna may require periodic cleaning. If cleaning becomes necessary:

- Note the antenna material and the process medium, and select a cleaning solution that will not react adversely with either.
- Remove the device from service and wipe the antenna clean using a cloth and suitable cleaning solution.

NOTICE
Penetration of moisture into the device <p>Device damage.</p> <ul style="list-style-type: none">• Make sure when carrying out cleaning and maintenance work that no moisture penetrates the inside of the device.

 WARNING
Electrostatic charge Danger of explosion in hazardous areas if electrostatic charges develop, for example, when cleaning plastic surfaces with a dry cloth. <ul style="list-style-type: none">• Prevent electrostatic charging in hazardous areas.

9.3 Maintenance and repair work

The device is maintenance-free. However, a periodic inspection according to pertinent directives and regulations must be carried out.

An inspection can include check of:

- Ambient conditions
- Seal integrity of the process connections, cable entries, and cover screws
- Reliability of power supply, lightning protection, and grounds

 WARNING
Maintenance during continued operation in a hazardous area There is a danger of explosion when carrying out repairs and maintenance on the device in a hazardous area. <ul style="list-style-type: none">• Isolate the device from power. - or - <ul style="list-style-type: none">• Ensure that the atmosphere is explosion-free (hot work permit).

 WARNING
Humid environment Danger of electric shock. <ul style="list-style-type: none">• Avoid working on the device when it is energized.• If working on an energized device is necessary, ensure that the environment is dry.• Make sure when carrying out cleaning and maintenance work that no moisture penetrates the inside of the device.

9.3.1 Unit repair and excluded liability

All changes and repairs must be done by qualified personnel, and applicable safety regulations must be followed. Please note the following:

- The user is responsible for all changes and repairs made to the device.
- All new components must be provided by Siemens.
- Restrict repair to faulty components only.
- Do not re-use faulty components.

9.3.2 Part replacement

If the antenna, lens, secondary O-ring, and spring washers require replacement due to damage or failure, they may be replaced without the need for re-calibration if of the same type and size.

Replacing the antenna

Changing to a different antenna type may be performed by a Siemens authorized repair center or personnel.

If the electronics or enclosure require replacement due to damage or failure, please ensure the correct antenna version is used, otherwise a re-calibration will need to be performed by Siemens authorized personnel.

Replacing the lens

1. Remove existing lens by turning it counter-clockwise until it separates from the unit.
2. Replace the O-ring between the lens and process connection with a new one.
3. Carefully thread the replacement lens, and turn it clockwise until resistance is encountered. Do not over-tighten the lens, as this will permanently damage it.
4. For flange installation instructions, see Flanged versions (Page 36).

Note

After installation of the new lens onto the flanged encapsulated antenna version and before mounting on the vessel/tank, some lenses may not appear to lie flush on the device, but this is normal and will not impact performance.

Raised-Face flange kits

Description	Process connection size	Part number
Replacement TFM™ 1600 PTFE Lens and Spring Washer Kit for ASME B16.5 Class 150 raised faced	2"	A5E32462817
	3"	A5E32462819
	4"	A5E32462820
	6"	A5E32462821
Replacement TFM™ 1600 PTFE Lens and Spring Washer Kit for JIS B 2220 10K raised Face	50A	A5E32462822
	80A	A5E32462823
	100A	A5E32462824
	150A	A5E32462825
Replacement TFM™ 1600 PTFE Lens and Spring Washer Kit for EN 1092-1 PN10/16 type B1 raised face	DN50	A5E32462826
	DN80	A5E32462827
	DN100	A5E32462828
	DN150	A5E32462829

Spare part kits

Description	Process connection size	Part number
ISO2852, Hygienic encapsulated antenna Lens and silicon O-ring	2"	A5E32572731
	3"	A5E32572745
	4"	A5E32572747
DIN11851, Hygienic encapsulated antenna Lens and silicon O-ring	DN50	A5E32572758
	DN80	A5E32572770
	DN100	A5E32572772
DIN11864-1, Hygienic encapsulated antenna Lens and silicon O-ring	DN50	A5E32572773
	DN80	A5E32572779
	DN100	A5E32572782
DIN11864-2/3, Hygienic encapsulated antenna Lens and silicon O-ring	DN50	A5E32572785
	DN80	A5E32572790
	DN100	A5E32572791
Tuchenhagen, Hygienic encapsulated antenna Lens and silicon O-ring	Type F	A5E32572794
	Type N	A5E32572795

Note

For more information about accessories such as clamps, seals and process connections, please see the catalog on the product page (<http://www.siemens.com/LR250>).

9.4 Disposal

Note

Special disposal required

The device includes components that require special disposal.

- Dispose of the device properly and environmentally through a local waste disposal contractor.
-

Diagnosing and troubleshooting

10.1 Communication troubleshooting















1. Check the following:
 - There is power at the device.
 - The LCD shows the relevant data.
 - The device can be programmed using the handheld programmer.
 - If any fault codes are being displayed see Acyclic Extended Diagnostics (General Fault Codes) (Page 286) for a detailed list.
2. Verify that the wiring connections are correct.
3. Check the PROFIBUS address and make sure all devices are at unique PROFIBUS addresses.
4. See the table below for specific symptoms.

Symptom	Corrective action
The device cannot be programmed via the handheld programmer.	<ul style="list-style-type: none"> • Make sure Write Protection (6.2.1.) is set to the unlock value.
You try to set a SITRANS LR250 parameter via remote communications but the parameter remains unchanged.	<ul style="list-style-type: none"> • Ensure Remote Lockout (6.1.1.) is disabled. • Ensure Write Protection (6.2.1.) is set to the unlock value. • See Resetting the PROFIBUS address to 126 (Page 97) to disable an address lock.
The PLC value equals the display value but does not correspond to actual material level.	<ul style="list-style-type: none"> • Ensure Scaling in AIFB1 is correctly entered. • Ensure High Calibration Point is correctly entered. • View the echo profile to see if the wrong echo is being selected. If so, see Operation Troubleshooting (Page 184) for possible causes and corrective action.
The PLC value is not equal to the displayed value (regardless of actual material level).	<ul style="list-style-type: none"> • Confirm you are looking at the right spot in the PLC. • Ensure scaling has not been programmed into the PLC: all scaling should be performed by the LR250. • Check the network to ensure the PLC is communicating with the LR250.

If you continue to experience problems go to our website and check the FAQs for SITRANS LR250:

Product page (<http://www.siemens.com/LR250>), or contact your Siemens representative.







10.2 Device status icons











Icon	Priority Level	Meaning
	1	<ul style="list-style-type: none"> Maintenance alarm Measurement values are not valid
	2	<ul style="list-style-type: none"> Maintenance warning: maintenance demanded immediately Measured signal still valid
	3	<ul style="list-style-type: none"> Maintenance required Measured signal still valid
	1	<ul style="list-style-type: none"> Process value has reached an alarm limit
	2	<ul style="list-style-type: none"> Process value has reached a warning limit
	3	<ul style="list-style-type: none"> Process value has reached a tolerance limit
	1	<ul style="list-style-type: none"> Configuration error Device will not work because one or more parameters/components is incorrectly configured
	2	<ul style="list-style-type: none"> Configuration warning Device can work but one or more parameters/components is incorrectly configured
	3	<ul style="list-style-type: none"> Configuration changed Device parameterization not consistent with parameterization in project. Look for info text.
	1	<ul style="list-style-type: none"> Manual operation (local override) Communication is good; device is in manual mode.
	2	<ul style="list-style-type: none"> Simulation or substitute value Communication is good; device is in simulation mode or works with substitute values.
	3	<ul style="list-style-type: none"> Out of operation Communication is good; device is out of action.
		<ul style="list-style-type: none"> No data exchange
		<ul style="list-style-type: none"> Write access enabled
		<ul style="list-style-type: none"> Write access disabled









10.3 General fault codes

Note

- The status icon shown associated with each fault is the default icon in Condensed Mode.
- If more than one fault is present, the device status indicator and text for each fault alternate at 2 second intervals.
- Some faults cause the device to go to Fail-safe mode (Fault 52). These are indicated with an asterisk (*).





Code/ Icon		Meaning	Corrective Action
S: 0 	*	The device was unable to get a measurement within the Fail-safe LOE Timer period. Possible causes: faulty installation, antenna material buildup, foaming/other adverse process conditions, invalid configuration range.	<ul style="list-style-type: none"> • Ensure installation details are correct. • Ensure no antenna material buildup. Clean if necessary. • Adjust process conditions to minimize foam or other adverse conditions. • Correct configuration range. • If fault persists, contact your local Siemens representative.
S: 2 	*	Unable to collect profile because of a power condition that is outside the operating range of the device.	Repair required: contact your local Siemens representative.
S: 3 		Device is nearing its lifetime limit according to the value set in Reminder 1 (Required) (4.2.5.) .	Replacement is recommended.
S: 4 		Device is nearing its lifetime limit according to the value set in Reminder 2 (Demanded) (4.2.6.) .	Replacement is recommended.
S: 6 		Sensor is nearing its lifetime limit according to the value set in Reminder 1 (Required) (4.3.5.) .	Replacement is recommended.
S: 7 		Sensor is nearing its lifetime limit according to the value set in Reminder 2 (Demanded) (4.3.6.) .	Replacement is recommended.

Code/ Icon		Meaning	Corrective Action
S: 8 		Service interval as defined in Reminder 1 (Required) (4.4.5.) has expired.	Perform service.
S: 9 		Service interval as defined in Reminder 2 (Demanded) (4.4.6.) has expired.	Perform service.
S: 10 		Input parameters Low Calibration Point (1.6.) and High Calibration Point (1.7.) are the same.	<ul style="list-style-type: none"> • Check calibration settings of device. • Ensure settings for High Calibration Point and Low Calibration Point are different.
S: 11 		Internal temperature sensor failure.	Repair required: contact your local Siemens representative.
S: 12 		Internal temperature of device has exceeded specifications: it is operating outside its temperature range.	<ul style="list-style-type: none"> • Relocate device and/or lower process temperature enough to cool device. • Inspect for heat-related damage and contact your local Siemens representative if repair is required. • Fault code will persist until a manual reset is performed using SIMATIC PDM or the LCD interface.
S: 14 		Input Scaling (2.6.5.) Upper and lower values for AIFB1 are the same.	<ul style="list-style-type: none"> • Check configuration for AIFB1. • Ensure that Upper Value and Lower Value (Input Scaling) are not the same.
S: 15 		Input Scaling (2.6.5.) Upper and lower values for AIFB2 are the same.	<ul style="list-style-type: none"> • Check configuration for AIFB2. • Ensure that Upper Value and Lower Value (Input Scaling) are not the same.
S: 17 		Calibration interval as defined in Reminder 1 (Required) (4.5.5.) has expired.	Perform calibration.
S: 18 		Calibration interval as defined in Reminder 2 (Demanded) (4.5.6.) has expired.	Perform calibration.
S: 28 	*	Internal device failure caused by a RAM memory error.	Repair required: contact your local Siemens representative.
S: 29 	*	EEPROM damaged.	Repair required: contact your local Siemens representative.

Code/ Icon		Meaning	Corrective Action
S: 31 	*	Flash error.	Repair required: contact your local Siemens representative.
S: 32 		IDENT number conflict.	Ensure value of the Ident number selector is correct for the network configuration. If it is correct, the device needs to be re parameterized by the PLC.
S: 33 	*	Factory calibration for the internal temperature sensor has been lost.	Repair required: contact your local Siemens representative.
S: 34 	*	Factory calibration for the device has been lost.	Repair required: contact your local Siemens representative.
S: 35 	*	Factory calibration for the device has been lost.	Repair required: contact your local Siemens representative.
S: 36 	*	Unable to start microwave module.	Repair required: contact your local Siemens representative.
S: 37 	*	Measurement hardware problem.	Repair required: contact your local Siemens representative.
S: 38 	*	Microwave module hardware failure: unable to calculate distance measurement.	Repair required: contact your local Siemens representative.
S: 43 	*	Factory calibration for the radar receiver has been lost.	Repair required: contact your local Siemens representative.

10.4 Operation troubleshooting

Operating symptoms, probable causes, and resolutions.

Symptom	Cause	Action
Display shows  S: 0 LOE	level or target is out of range	<ul style="list-style-type: none"> check specifications check Low Calibration Pt. (1.6.) increase Confidence (2.5.9.1.)
Display shows  S: 0 LOE	material build-up on antenna	<ul style="list-style-type: none"> clean the antenna re-locate SITRANS LR250
Display shows  S: 0 LOE	location or aiming: <ul style="list-style-type: none"> poor installation flange not level Auto False Echo Suppression may be incorrectly applied 	<ul style="list-style-type: none"> check to ensure nozzle is vertical ensure end of antenna protrudes from end of nozzle review Auto False Echo Suppression (Page 246) ensure Auto False Echo Suppression Range is set correctly
Display shows  S: 0 LOE	antenna malfunction: <ul style="list-style-type: none"> temperature too high physical damage excessive foam multiple echoes 	<ul style="list-style-type: none"> check temperature in Maximum Value (3.3.2.) use foam deflector or stillpipe relocate use a defoamer set Algorithm (2.5.7.1.) to tF (trueFirst echo)
Reading does not change, but the level does	SITRANS LR250 processing wrong echo, for example, vessel wall, or structural member	<ul style="list-style-type: none"> re-locate SITRANS LR250 check nozzle for internal burrs or welds rotate device 90° use Auto False Echo Suppression (2.5.10.1.) if necessary: see Auto False Echo Suppression (Page 246)
Measurement is consistently off by a constant amount	<ul style="list-style-type: none"> setting for Low Calibration Point (2.3.7.1.) not correct setting for Sensor Offset (2.3.7.3.) not correct 	<ul style="list-style-type: none"> check distance from sensor reference point to Low Calibration Point (2.3.7.1.) check Sensor Offset (2.3.7.3.)
Screen blank	power error	<ul style="list-style-type: none"> check nameplate rating against voltage supply check power wiring or source
	too much load resistance	<ul style="list-style-type: none"> change barrier type, or remove something from the loop, or increase supply voltage reduce wire distance or use larger gage wire

Symptom	Cause	Action
Reading erratic	echo confidence weak	<ul style="list-style-type: none"> refer to Confidence (2.5.9.1.) use Auto False Echo Suppression (2.5.10.1.) and Auto False Echo Suppression Range (2.5.10.2.) use foam deflector or stillpipe
	liquid surface vortexed	<ul style="list-style-type: none"> decrease Fill Rate (2.3.8.2.) relocate device to side pipe increase confidence threshold in Echo Threshold (2.5.7.3.)
	material filling	<ul style="list-style-type: none"> Re-locate SITRANS LR250
Reading response slow	Fill Rate (2.3.8.2.) setting incorrect	<ul style="list-style-type: none"> increase measurement response if possible
Reads correctly but occasionally reads high when vessel is not full	<ul style="list-style-type: none"> detecting close range echo build up near top of vessel or nozzle nozzle problem 	<ul style="list-style-type: none"> clean the antenna use Auto False Echo Suppression (2.5.10.1.) and Auto False Echo Suppression Range (2.5.10.2.)
Level reading lower than actual material level	<ul style="list-style-type: none"> material is within Near Range zone multiple echoes processed 	<ul style="list-style-type: none"> decrease Near Range (2.5.1.) (minimum value depends on antenna type) raise SITRANS LR250 ensure Algorithm (2.5.7.1.) is set to tF (First echo)
	<ul style="list-style-type: none"> vessel near empty and low dK material 	<ul style="list-style-type: none"> ensure Material (1.2.) selection is LIQUID LOW DK set Position Detect (2.5.7.2.) to Hybrid check the setting for CLEF Range (2.5.7.4.): see the table below Propogation Factor (2.5.3.) for recommended settings

Technical data

Note

- Siemens makes every attempt to ensure the accuracy of these specifications but reserves the right to change them at any time.
-

11.1 Power

	General Purpose: Intrinsically Safe: Non-Sparking: Non-incendive:
---	--

Bus powered Per IEC 61158-2 (PROFIBUS PA)
 Current consumed 15 mA

11.2 Performance

Reference operating conditions according to IEC 60770-1

Ambient temperature	15 to 25 °C (59 to 77 °F)
Humidity	45 to 75% relative humidity
Ambient pressure	860 to 1060 mbar a (86000 to 106000 N/m ² a)
Interference reflections	minimum 20 dB lower than the main target reflections

Measurement Accuracy (measured in accordance with IEC 60770-1)

Maximum measured error	=3 mm (0.12") ^{1) 2) 3)} including hysteresis and non-repeatability	
Frequency	K-band	
Maximum measurement range ⁴⁾	1.5" antenna	10 m (32.8 ft) ⁵⁾
	2" threaded PVDF antenna	
	2"/DN50/50A Flanged encapsulated antenna (FEA)	
	2", ISO 2852, DN50 DIN11864-1/2/3, DN50 DIN11851, Tuchenhagen Types F and N Hygienic encapsulated antenna (HEA)	
	all other versions	20 m (65.6 ft)
Minimum detectable distance	50 mm (2") from end of antenna ⁶⁾	
Update time ⁷⁾	minimum 1 second, depending on settings for Response Rate (2.3.8.1.) and LCD Fast Mode (4.9.) .	
Influence of ambient temperature	< 0.003% / K (average over full temperature range, referenced to maximum range)	
Dielectric constant of material measured	dK > 1.6 [antenna and application dependent ⁸⁾]	
Memory	non-volatile EEPROM	
	no battery required	

1) The statistical accuracy is typically 3 mm (0.12") 90% of the time, when tested in accordance with IEC 60770-1.

2) Under severe EMI/EMC environments per IEC 61326-1 or NAMUR NE21, the device error may increase to a maximum of 10 mm (0.4").

3) For 2" threaded PVDF antenna, Flanged encapsulated antennas and Hygienic encapsulated antennas, the maximum measured error <500 mm from the sensor reference point =25 mm (1").

4) From sensor reference point: see Dimension drawings (Page 195) and Flanged Horn with extension (Page 202).

5) 20 m (65.6 ft) possible in a stillpipe/bypass

6) Minimum range is antenna length +50 mm (2"). See Dimension drawings (Page 195).

7) Reference conditions: **Response Rate (2.4.1.)** set to **FAST**, **LCD Fast Mode (4.9.)** set to **ON**.

8) For 1.5" (40 mm) antenna and 2" (50 mm) threaded PVDF antenna, 2"/DN50/50A flanged encapsulated antenna, and 2" ISO 2852, DN50 DIN 11864-1/2/3, DN50 DIN11851, Tuchenhagen Types F and N hygienic encapsulated antenna the minimum dK is limited to 3 unless a stillpipe is used.

See Flanged horn antenna (Page 200).

See Flanged encapsulated antenna (3"/DN80/80A sizes and larger) (Page 206).

See Hygienic encapsulated antenna (2" ISO 2852 sanitary clamp) (Page 208).

11.3 Interface

Communication	PROFIBUS PA	
Configuration	Remote	Siemens SIMATIC PDM
	Local	Siemens infrared handheld programmer
	Display (local) ¹⁾	graphic LCD, with bar graph representing level

¹⁾ Display quality will be degraded in temperatures below $-25\text{ }^{\circ}\text{C}$ ($-13\text{ }^{\circ}\text{F}$) and above $+65\text{ }^{\circ}\text{C}$ ($+149\text{ }^{\circ}\text{F}$).

11.4 Mechanical

Process connection:	Threaded connection	1.5" NPT (ASME B1.20.1), R (BSPT, EN 10226-1) ^{a)} or G (BSPP, EN ISO 228-1) or 2" NPT (ASME B1.20.1), R (BSPT, EN 10226-1) or G (BSPP, EN ISO 228-1) or 3" NPT (ASME B1.20.1), R (BSPT, EN 10226-1) or G (BSPP, EN ISO 228-1)	
	Flange connection (flat-face)	2, 3, 4" (ASME 150 lb, 300 lb) DN50, DN80, DN100 (PN 10/16, PN 25/40) 50A, 80A, 100A (JIS 10K)	
	Materials	316L /1.4404 or 316L /1.4435 stainless steel	
	Flange connection (raised face)	DN50, DN80, DN100, DN150 (PN 10/16, PN 25/40)	
	Materials	1.4404 or 1.4435 stainless steel, optional Alloy N06022/2.4602 (Hastelloy [®] C-22 or equivalent)	
	Flanged encapsulated antenna (FEA) connection (raised face)	2, 3, 4, 6" (ASME 150 lb); DN50, DN80, DN100, DN150 (PN10/16); 50A, 80A, 100A, 150A (JIS 10K)	
	Materials	316L /1.4404 or 316L /1.4435 stainless steel	
Hygienic encapsulated antenna (HEA) connection	ISO 2852 (2, 3, 4") DIN 11851 (DN50, DN80, DN100) DIN 11864-1/2/3 (DN50, DN80, DN100) Tuchenhagen (Type F [50 mm] and Type N [68 mm]) 316L /1.4404 or 316L /1.4435 stainless steel		
	Materials	ISO 2852 (2, 3, 4") DIN 11864-3 (DN50, DN80, DN100)	clamp: 304/1.4301 stainless steel

Technical data

11.4 Mechanical

		Tuchenhagen (Type F [50 mm] and Type N [68 mm]) 316L /1.4404 or 316L/1.4435 stainless steel	clamp: 304/1.4301 stainless steel nut connection: 303/1.4305 stainless steel
		DIN 11851/11864-1 (DN50, DN80, DN100)	captive slotted nut connection: 304L/1.4307
		DIN 11864-2 (DN50, DN80, DN100)	mounting nuts and bolts: 304/1.4301 stainless steel
Antenna:	Horn	standard 1.5" (40 mm), 2" (50 mm), 3" (80 mm), and 4" (100 mm) horn, optional 100 mm (4") horn extension	
	Materials	316L stainless steel with PTFE emitter optional Alloy N06022/2.4602 (Hastelloy®C-22 or equivalent) with PTFE emitter	
	Threaded PVDF antenna	2" (50 mm)	
	Wetted materials	PVDF (Polyvinylidene fluoride)	
	Flanged encapsulated antenna	316L /1.4404 or 316L /1.4435 stainless steel	
	Wetted materials	TFM™ 1600 PTFE lens	
Antenna:	Hygienic encapsulated antenna	316L/1.4404 or 316L/1.4435 stainless steel	
	Wetted material	TFM™ 1600 PTFE (plus chosen seal)	
Enclosure	Construction	aluminum, polyester powder-coated	
	Conduit entry	2 x M20x1.5, or 2 x ½" NPT	
	Ingress protection	Type 4X/NEMA 4X, Type 6/NEMA 6, IP67, IP68	
Weight (excluding extensions):	1.5" threaded connection with 1.5" horn antenna	approximately 5.1kg (11.2 lb)	
	2" threaded connection with 2" horn antenna	approximately 5.5 kg (12.1 lb)	
	3" threaded connection with 3" horn antenna	approximately 7.0 kg (15.4 lb)	
	2" threaded PVDF antenna	approximately 3.3 kg (7.27 lb)	
	DN50 PN 10/16 or 2" 150 lb flat-face flange with 2" horn antenna	approximately 8 kg (17.6 lb)	
	DN100 PN 25/40 or 4" ASME 300 lb flat-face flange with 4" horn antenna	approximately 17.4 kg (38.3 lb)	
	DN50 PN 10/16 raised-face flange with 2" horn antenna	approximately 6 kg (13.2 lb)	
	DN100 PN 25/40 raised-face flange with 4" horn antenna	approximately 11.3 kg (24.9 lb)	

2" ASME 150 lb FEA	approximately 7.0 kg (15.4 lb)
3" ASME 150 lb FEA	approximately 10.7 kg (23.6 lb)
4" ASME 150 lb FEA	approximately 13.1 kg (28.9 lb)
6" ASME 150 lb FEA	approximately 17.7 kg (39 lb)
DN50 PN 10/16 FEA	approximately 7.1 kg (15.7 lb)
DN80 PN 10/16 FEA	approximately 10.1 kg (22.3 lb)
DN100 PN 10/16 FEA	approximately 11.1 kg (24.5 lb)
DN150 PN 10/16 FEA	approximately 15.9 kg (35.1 lb)
50 A JIS 10K FEA	approximately 6.5 kg (14.3 lb)
80 A JIS 10K FEA	approximately 9 kg (19.8 lb)
100 A JIS 10K FEA	approximately 10.1 kg (22.3 lb)
150 A JIS 10K FEA	approximately 16.3 kg (35.9 lb)
2" ISO2852 HEA	approximately 4.7 kg (10.4 lb)
3" ISO2852 HEA	approximately 6.3 kg (13.9 lb)
4" ISO2852 HEA	approximately 6.8 kg (15 lb)
DN50 DIN 11864-1 HEA	approximately 4.8 kg (10.6 lb)
DN80 DIN 11864-1 HEA	approximately 6.7 kg (14.8 lb)
DN100 DIN 11864-1 HEA	approximately 7.1 kg (15.7 lb)
DN50 DIN 11864-2 HEA	approximately 5.0 kg (11 lb)
DN80 DIN 11864-2 HEA	approximately 7.2 kg (15.9 lb)
DN100 DIN 11864-2 HEA	approximately 7.9 kg (17.4 lb)
DN50 DIN 11864-3 HEA	approximately 4.8 kg (10.6 lb)
DN80 DIN 11864-3 HEA	approximately 6.6 kg (14.6 lb)
DN100 DIN 11864-3 HEA	approximately 7.2 kg (15.9 lb)
DN50 DIN 11851 HEA	approximately 4.8 kg (10.6 lb)
DN80 DIN 11851 HEA	approximately 6.8 kg (15 lb)
DN100 DIN 11851 HEA	approximately 7.2 kg (15.9 lb)
Tuchenhagen Type F HEA	approximately 4.8 kg (10.6 lb)
Tuchenhagen Type N HEA	approximately 4.9 kg (10.8 lb)

a) For use with 1.5" (40 mm) horn antennas only.

11.5 Environmental

Note

- For the specific configuration you are about to use or install, check transmitter nameplate and see Approvals (Page 193).
- Use appropriate conduit seals to maintain IP or NEMA rating.

Location	indoor/ outdoor
Altitude	5000 m (16,404 ft) max.
Ambient temperature	-40 to +80 °C (-40 to +176 °F)
Relative humidity	suitable for outdoor Type 4X/NEMA 4X, Type 6/NEMA 6, IP67, IP68 enclosure (see note above)
Installation category	I
Pollution degree	4

11.6 Process

Note

The maximum temperature is dependent on the process connection, antenna materials, and vessel pressure. For more detailed information see Maximum Process Temperature Chart (Page 251) and Process Pressure/Temperature derating curves (Page 253).

Temperature at process connection	Standard Horn antenna (Threaded or Flanged):	with FKM O-ring	-40 to +200 °C (-40 to +392 °F)
		with FFKM O-ring	-20 to +200 °C (-4 to +392 °F)
	2" NPT / BSPT / G Threaded PVDF antenna:		-40 to +80 °C (-40 to +176 °F)
	Flanged encapsulated antenna (FEA)		-40 to +170 °C (-40 to +338 °F)
	Hygienic encapsulated antenna (HEA)		-40 to +170 °C (-40 to +338 °F)
			with FKM seals used on process connection: -20 to +170 °C (-4 to +338 °F)
			with EPDM seals used on process connection: -40 to +120 °C (-40 to +248 °F)
Pressure (vessel)	Refer to process connection tag and Process Pressure/Temperature derating curves (Page 253).		

11.7 Approvals

Note

The device nameplate lists the approvals that apply to your device.

Application type	LR250 version	Approval rating	Valid for:
Non-hazardous	General purpose	CSAus/c, FM, CE, RCM	N. America, Europe
	Radio	Europe (R&TTE), FCC, Industry Canada	
Hazardous	Intrinsically safe (Page 46)	ATEX II 1G, Ex ia IIC T4 Ga ATEX II 1D, Ex ia ta IIIC T100 °C Da	Europe
		IECEX SIR 05.0031X, Ex ia IIC T4 Ga Ex ia ta IIIC T100 °C Da	International
	FM/CSA Class I, Div. 1, Groups A, B, C, D Class II, Div. 1, Groups E, F, G Class III T4	US/Canada	
	INMETRO DNV 12.0087 X Ex ia IIC T4 Ga Ex ia ta IIIC T100 °C Da IP65/IP67 -40 °C ≤ Ta ≤ +80 °C DNV #OCP 0017 ABNT NBR IEC 60079-0:2008, ABNT NBR IEC 60079-11:2009, ABNT NBR IEC 60079-26:2008, ABNT NBR IEC 60079-31:2011	Brazil	
	NEPSI Ex ia IIC T4 Ga Ex iaD 20 T90 IP67 DIP A20 T _A 90 °C	China	
	Non-Sparking (Page 49)	ATEX II 3 G, Ex nA IIC T4 Gc NEPSI Ex nA IIC T4 Gc	Europe China
Non-incendive (Page 49)	FM/CSA Class I, Div. 2, Groups A, B, C, D T5	US/Canada	
Marine	Lloyd's Register of Shipping ABS Type Approval BV Type Approval		

11.8 Programmer (infrared keypad)

Note

Battery is non-replaceable with a lifetime expectancy of 10 years in normal use. To estimate the lifetime expectancy, check the nameplate on the back for the serial number. The first six numbers show the production date (mmddyy), for example, serial number 032608101V was produced on March 26, 2008.

Siemens Milltronics Infrared IS (Intrinsically Safe) Handheld Programmer for hazardous and all other locations (battery is non-replaceable).

Approvals	CE FM/CSA Class I, II, III, Div. 1, Gr. A to G T6 ATEX II 1GD Ex ia IIC T4 Ga Ex iaD 20 T135 °C IECEX Ex ia IIC T4 Ga Ex iaD 20 T135 °C INMETRO Ex ia IIC T4 Ga Ex ia IIIC T135 °C Da
Ambient temperature	-20 to +50 °C (-5 to +122 °F)
Interface	proprietary infrared pulse signal
Power	3 V non-replaceable lithium battery
Weight	150 g (0.3 lb)
Color	black
Part number	7ML1930-1BK

12

Dimension drawings

12.1 Threaded horn antenna

Note

- Process temperature and pressure capabilities are dependent upon information on the process connection tag. Reference drawing listed on the tag is available for download from our website under **Support/Installation drawings/Level Measurement/Continuous - Radar/LR250**:
Product page (<http://www.siemens.com/LR250>)
 - Process connection drawings are also available for download from the **Installation Drawings page**.
 - Signal amplitude increases with horn diameter, so use the largest practical size.
 - Optional extensions can be installed below the threads.
-

Dimension drawings

12.1 Threaded horn antenna

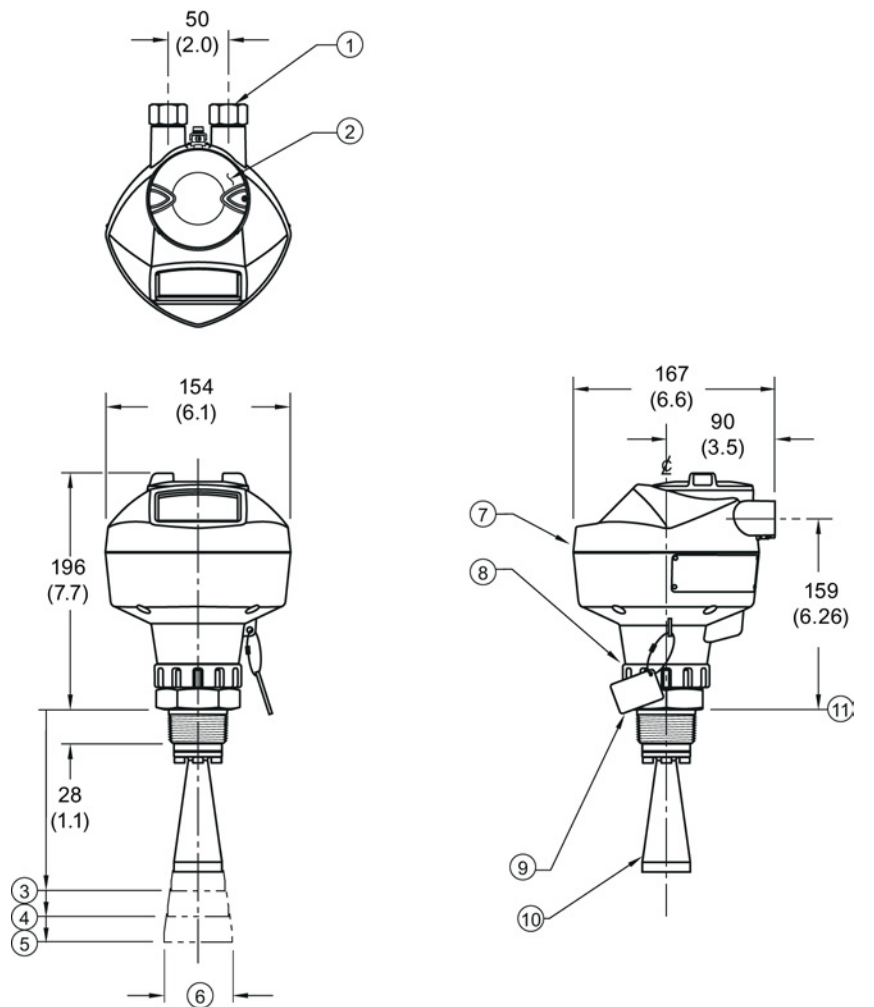

- | | |
|--|--------------------------|
| ① 1/2" NPT cable entry, or M20 cable gland | ⑦ enclosure/electronics |
| ② threaded cover | ⑧ retaining collar |
| ③ 2" horn | ⑨ process connection tag |
| ④ 3" horn | ⑩ horn |
| ⑤ 4" horn | ⑪ sensor reference point |
| ⑥ horn O.D. | |

Dimensions in mm (inch)

Threaded horn dimensions

Antenna Type	Antenna O.D. in mm (inch)	Height to sensor reference point, in mm (inch) ^{a)}			Beam Angle (°) ^{b)}	Measurement range, in m (ft)
		1-1/2" threaded connection	2" threaded connection	3" threaded connection		
1.5"	39.8 (1.57)	135 (5.3)	N/A	N/A	19	10 (32.8)
2"	47.8 (1.88)	N/A	166 (6.55)	180 (7.09)	15	20 (65.6)
3"	74.8 (2.94)	N/A	199 (7.85)	213 (8.39)	10	20 (65.6)
4"	94.8 (3.73)	N/A	254 (10)	268 (10.55)	8	20 (65.6)

^{a)} Height from bottom of horn to sensor reference point as shown: see dimension drawing.

^{b)} -3dB in the direction of the polarization axis. For an illustration, see Polarization reference point (Page 31).

12.2 Threaded horn antenna with extension

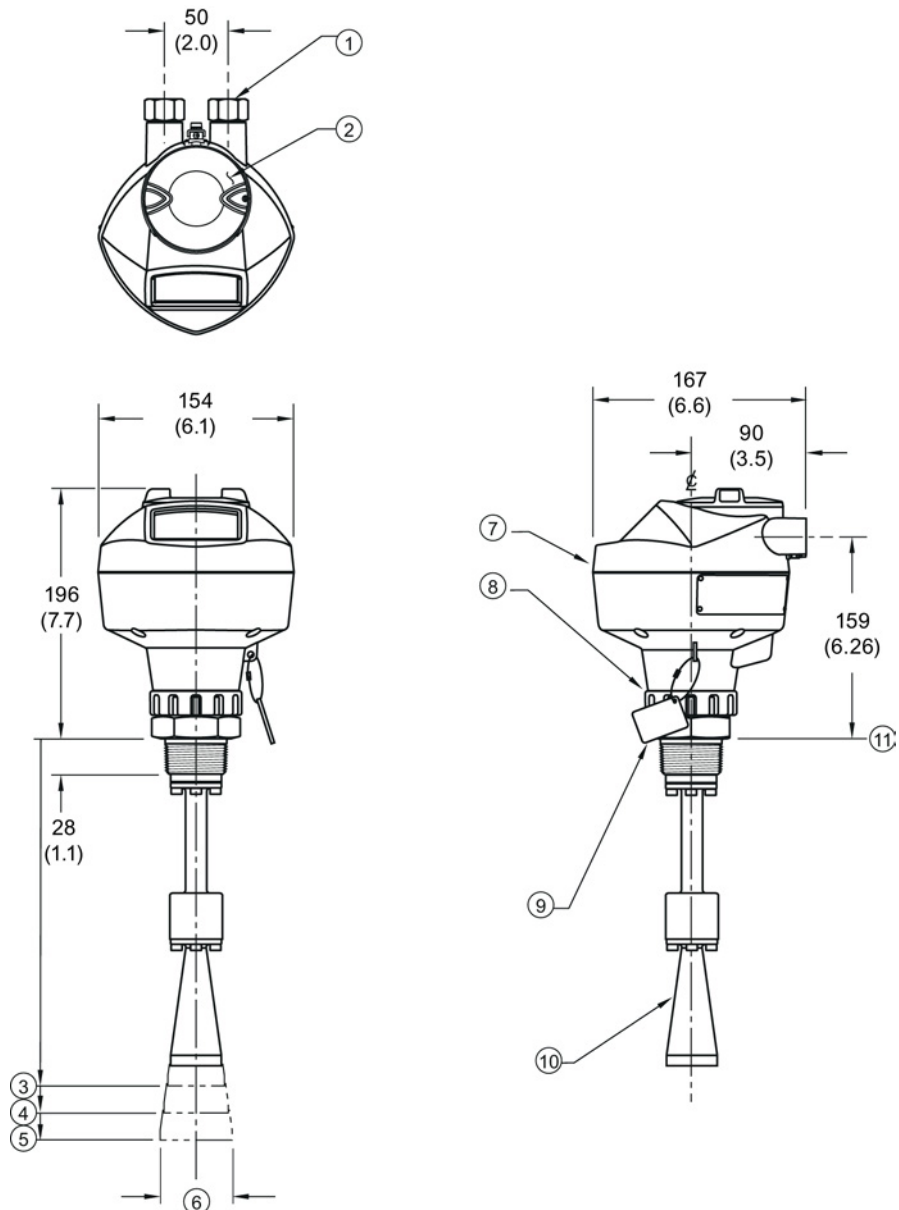

- | | | | |
|---|--|---|------------------------|
| ① | ½" NPT cable entry, or M20 cable gland | ⑦ | enclosure/electronics |
| ② | threaded cover | ⑧ | retaining collar |
| ③ | 2" horn | ⑨ | process connection tag |
| ④ | 3" horn | ⑩ | horn |
| ⑤ | 4" horn | ⑪ | sensor reference point |
| ⑥ | horn O.D. | | |

Dimensions in mm (inch)

Threaded horn with extension dimensions

Antenna Type	Antenna O.D. in mm (inch)	Height to sensor reference point, in mm (inch) ^{a)}			Beam Angle (°) ^{b)}	Measurement range in m (ft)
		1-1/2" threaded connection	2" threaded connection	3" threaded connection		
1.5"	39.8 (1.57)	235 (9.25)	N/A	N/A	19	10 (32.8)
2"	47.8 (1.88)	N/A	266 (10.47)	280 (11.02)	15	20 (65.6)
3"	74.8 (2.94)	N/A	299 (11.77)	313 (12.32)	10	20 (65.6)
4"	94.8 (3.73)	N/A	354 (13.94)	368 (14.49)	8	20 (65.6)

^{a)} Height from bottom of horn to sensor reference point as shown: see dimension drawing.

^{b)} -3dB in the direction of the polarization axis. For an illustration, see Polarization reference point (Page 31).

12.3 Flanged horn antenna

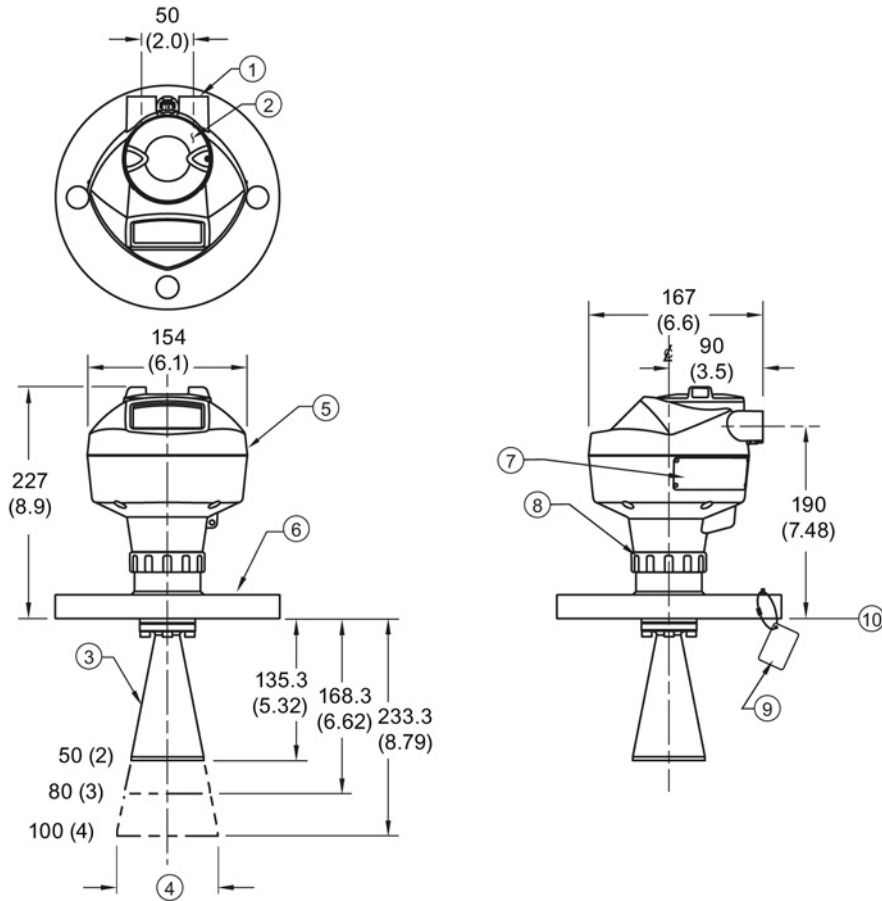

- | | | | |
|---|--|---|------------------------|
| ① | ½" NPT cable entry, or M20 cable gland | ⑥ | flange |
| ② | threaded cover | ⑦ | name-plate |
| ③ | horn | ⑧ | retaining collar |
| ④ | horn O.D. | ⑨ | process connection tag |
| ⑤ | enclosure/electronics | ⑩ | sensor reference point |

Dimensions in mm (inch)

Flanged Horn dimensions

Nominal horn size in mm (inch)	Horn O.D. in mm (inch)	Height to sensor reference point, in mm (inch) ^{a)}		Beam angle (°) ^{b)}	Measurement range, in m (ft)
		Stainless steel flange: raised or flat-face	Optional alloy flange ^{c)}		
50 (2)	47.8 (1.88)	135.3 (5.32)	138.3 (5.44)	15	
80 (3)	74.8 (2.94)	168.3 (6.62)	171.3 (6.74)	10	20 (65.6)
100 (4)	94.8 (3.73)	223.3 (8.79)	226.3 (8.90)	8	

^{a)}Height from bottom of horn to sensor reference point as shown: see Flanged horn antenna with extension (Page 202). See also Raised-Face flange per EN 1092-1 for flanged horn antenna (Page 228), or Flat-Face flange (Page 233).

^{b)}-3dB in the direction of the polarization axis (see Polarization reference point (Page 31) for an illustration).

^{c)}Optional alloy N06022/2.4602 (Hastelloy® C-22 or equivalent). See Raised-Face Flange Dimensions (Page 228).

Note

Heights to sensor reference point are for stainless steel flanges. For optional alloy N06022/2.4602 (Hastelloy® C-22 or equivalent) see Flanged Horn dimensions above.

12.4 Flanged horn antenna with extension

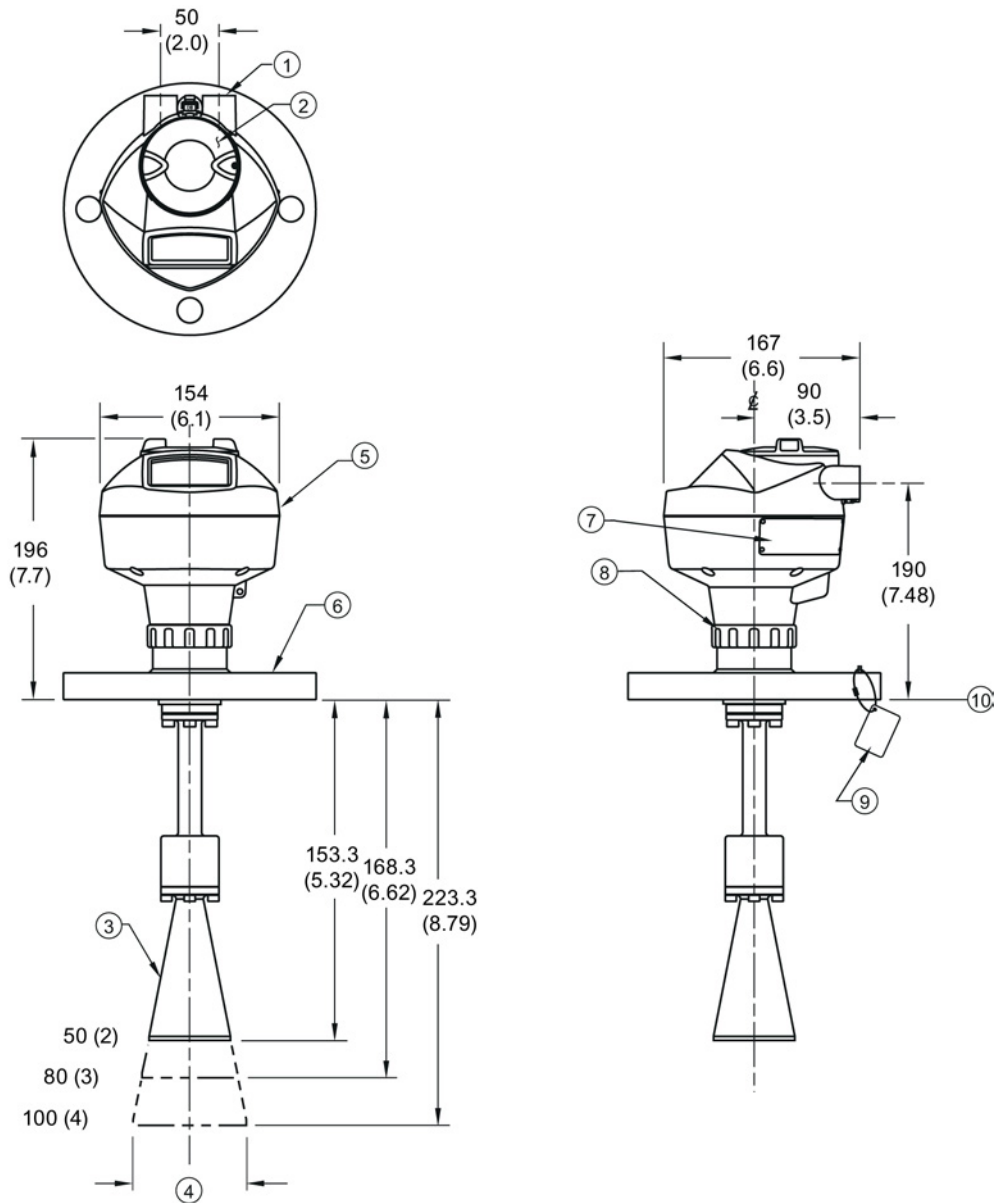

- | | | | |
|---|--|---|------------------------|
| ① | ½" NPT cable entry, or M20 cable gland | ⑥ | flange |
| ② | threaded cover | ⑦ | name-plate |
| ③ | horn | ⑧ | retaining collar |
| ④ | horn O.D. | ⑨ | process connection tag |
| ⑤ | enclosure/electronics | ⑩ | sensor reference point |

Dimensions in mm (inch)

Flanged horn with extension dimensions

Nominal horn size in mm (inch)	Horn O.D. in mm (inch)	Height to sensor reference point, in mm (inch) ^{a)}		Beam angle (°) ^{b)}	Measurement range, in m (ft)
		Stainless steel flange: raised or flat-face	Optional alloy flange ^{c)}		
50 (2)	47.8 (1.88)	235.3 (9.26)	238.3 (9.38)	15	
80 (3)	74.8 (2.94)	268.3 (10.56)	271.3 (10.68)	10	20 (65.6)
100 (4)	94.8 (3.73)	323.3 (12.73)	326.3 (12.85)	8	

^{a)}Height from bottom of horn to sensor reference point as shown: See also Raised-Face flange per EN 1092-1 for flanged horn antenna (Page 228) or Flat-Face Flange. (Page 233)

^{b)}-3dB in the direction of the polarization axis (see Polarization reference point (Page 31) for an illustration).

^{c)}Optional alloy N06022/2.4602 (Hastelloy® C-22 or equivalent). See Raised-Face flange per EN 1092-1 for flanged horn antenna (Page 228).

Note

Heights to sensor reference point are for stainless steel flanges. For optional alloy N06022/2.4602 (Hastelloy® C-22 or equivalent) see Flanged Horn dimensions above.

12.5 Flanged encapsulated antenna (2"/DN50/50A sizes only)

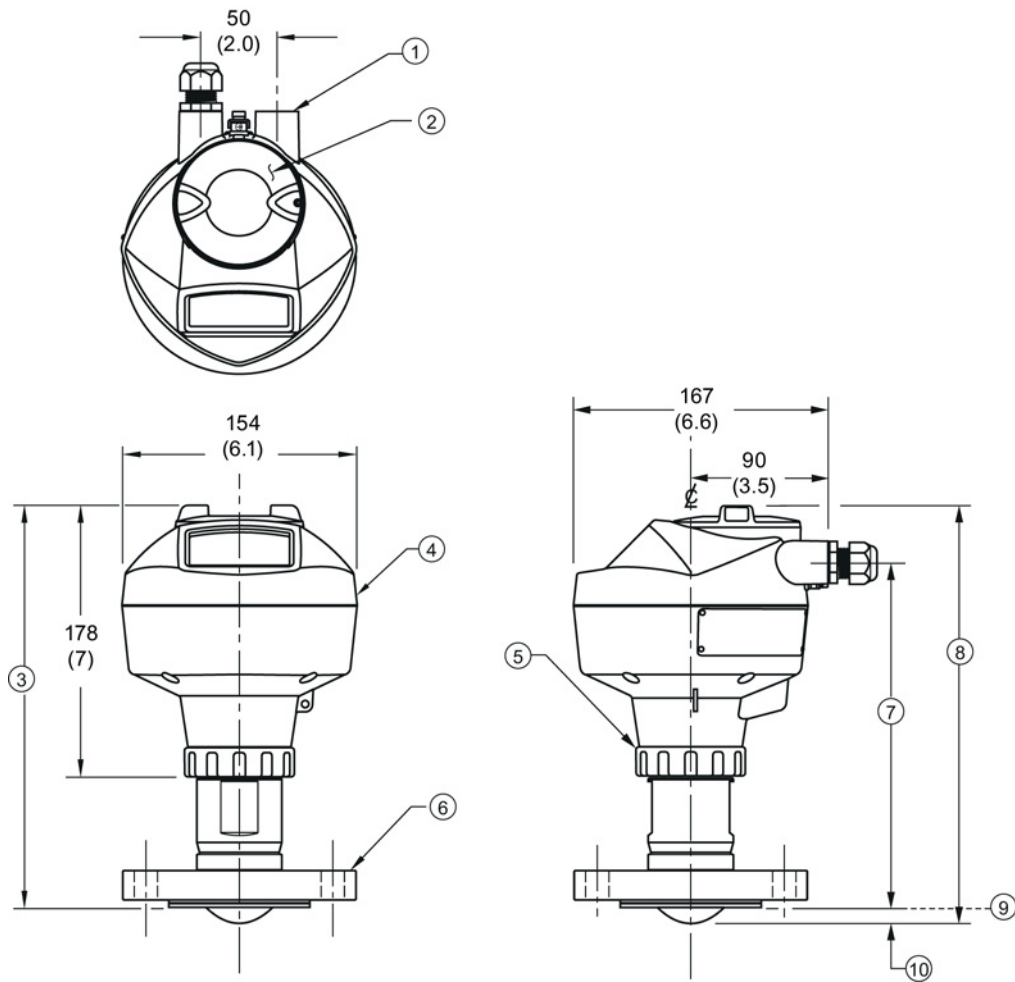

- | | | | |
|---|--|---|------------------------|
| ① | ½" NPT cable entry, or M20 cable gland | ⑥ | flange |
| ② | threaded cover | ⑦ | see table below |
| ③ | see table below | ⑧ | see table below |
| ④ | enclosure | ⑨ | sensor reference point |
| ⑤ | retaining collar | ⑩ | see table below |

Dimensions in mm (inch)

12.5 Flanged encapsulated antenna (2"/DN50/50A sizes only)

Flanged encapsulated antenna (2"/DN50/50A) dimensions

Flange size	③ mm (inch)	⑦ mm (inch)	⑧ mm (inch)	⑩ mm (inch) ¹⁾
2"/DN50/50A	263 (10.35)	223 (8.78)	274 (10.79)	11 (0.43)

1) Height from tip of lens to sensor reference point as shown.

Flange size	Flange class	Flange O.D. [mm (inch)]	Antenna aperture size [mm (inch)]	Beam angle (°) ¹⁾	Measurement range [m (ft)]
2"	150 LB	152 (5.98)	50 (1.97)	12.8	10 (32.8) ²⁾
DN50	PN10/16	165 (6.50)			
50A	10K	155 (6.10)			

1) -3 dB in the direction of the polarization axis.

2) 20m if installed in stillpipe

See Raised-Face Flange per EN 1092-1, (Page 230) and Polarization reference point (Page 31).

12.6 Flanged encapsulated antenna (3"/DN80/80A sizes and larger)

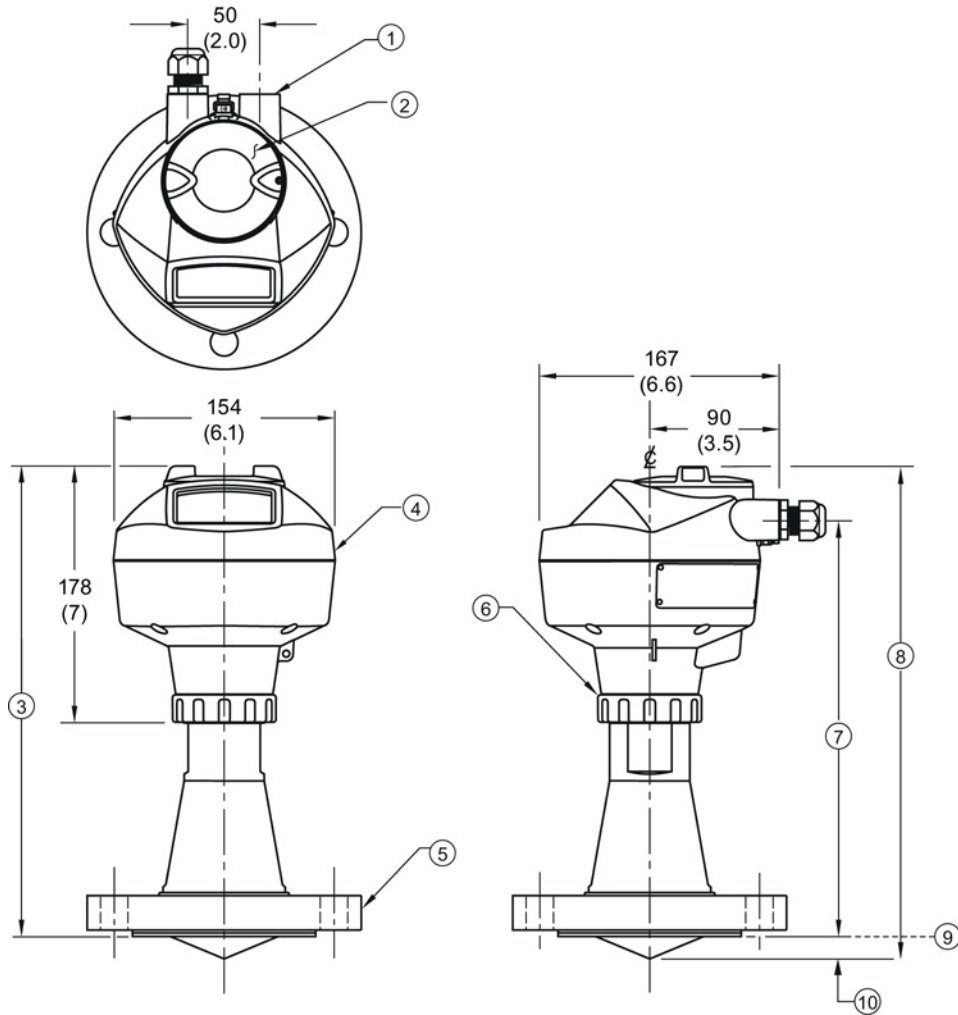

- | | | | |
|---|--|---|------------------------|
| ① | ½" NPT cable entry, or M20 cable gland | ⑥ | retaining collar |
| ② | threaded cover | ⑦ | see table below |
| ③ | see table below | ⑧ | see table below |
| ④ | enclosure | ⑨ | sensor reference point |
| ⑤ | flange | ⑩ | see table below |

Dimensions in mm (inch)

12.6 Flanged encapsulated antenna (3"/DN80/80A sizes and larger)

Flanged encapsulated antenna (3"/DN80/80A and larger) dimensions

Flange size	③ mm (inch)	⑦ mm (inch)	⑧ mm (inch)	⑩ mm (inch) ¹⁾
3"/DN80/80A	328 (12.91)	288 (11.34)	343 (13.50)	15 (0.59)
4"/DN100/100A	328 (12.91)	288 (11.34)	343 (13.50)	13 (0.51)
6"/DN150/150A	333 (13.11)	293 (11.54)	348 (13.70)	15 (0.59)

1) Height from tip of lens to sensor reference point as shown. See also Raised-Face Flange per EN 1092-1.

Flange size	Flange class	Flange O.D. [mm (inch)]	Antenna aperture size [mm (inch)]	Beam angle (°) ¹⁾	Measurement range [m (ft)]
3"	150 LB	190 (7.48)	75 (2.95)	9.6	20 (65.6)
DN80	PN10/16	200 (7.87)			
80A	10K	185 (7.28)			
4"	150 LB	230 (9.06)	75 (2.95)	9.6	20 (65.6)
DN100	PN10/16	220 (8.66)			
100A	10K	210 (8.27)			
6"	150 LB	280 (11.02)	75 (2.95)	9.6	20 (65.6)
DN150	PN10/16	285 (11.22)			
150A	10K	280 (11.02)			

1) -3 dB in the direction of the polarization axis.

See Raised-Face Flange per EN 1092-1 (Page 230), and Polarization reference point (Page 31).

12.7 Hygienic encapsulated antenna (2" ISO 2852 sanitary clamp)

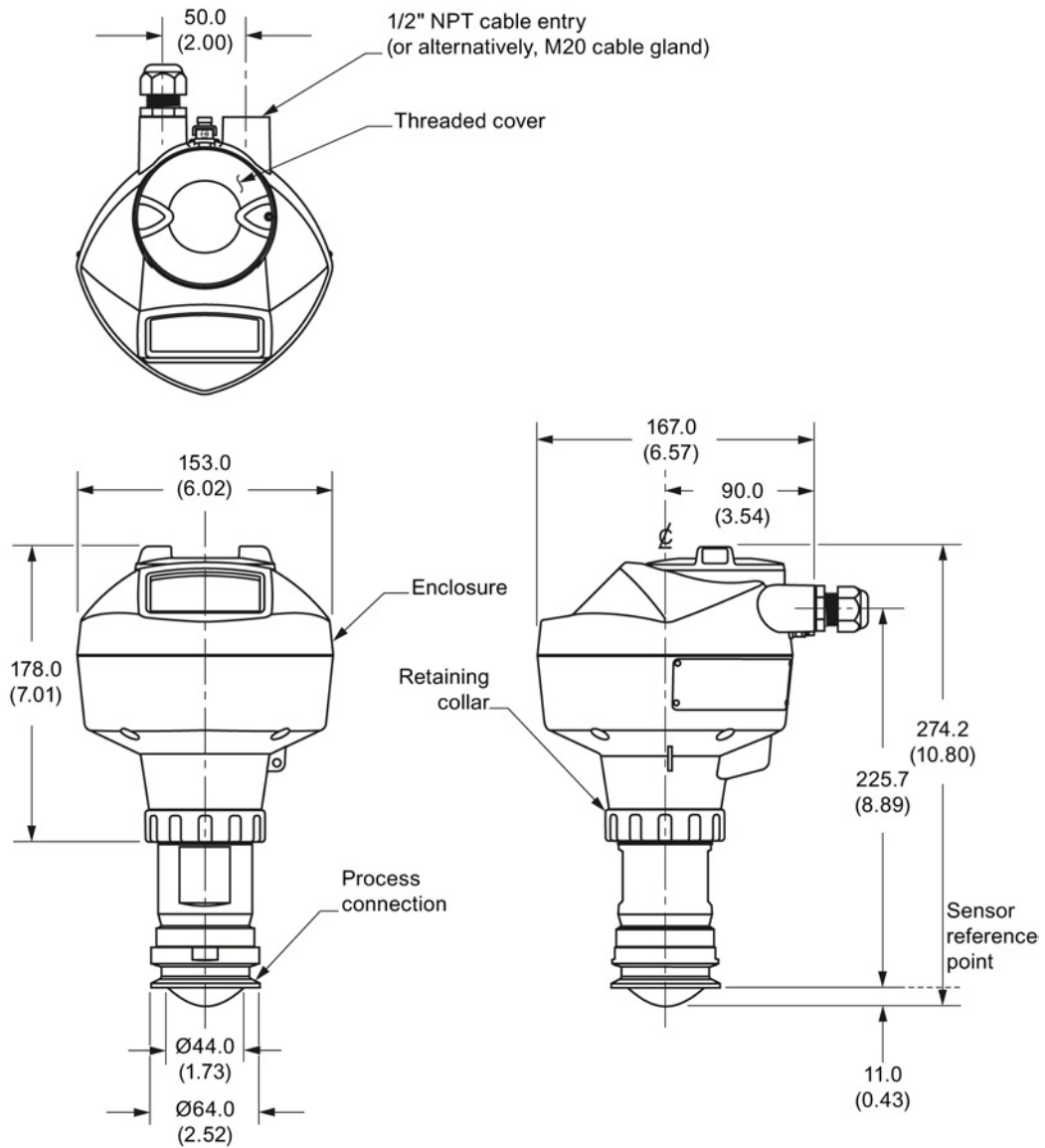

Dimensions in mm (inch)

12.8 Hygienic encapsulated antenna (3" ISO 2852 sanitary clamp)

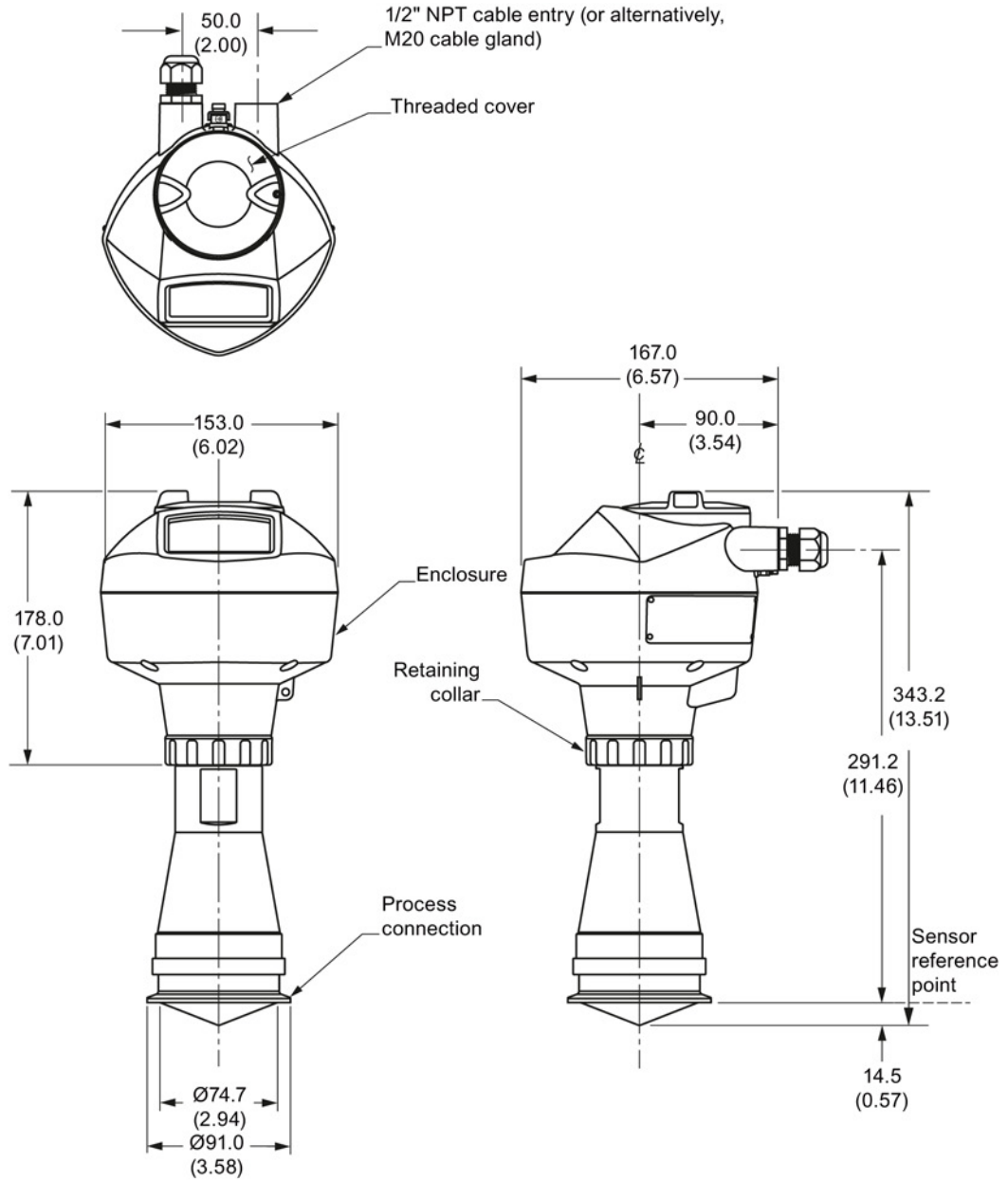

Dimensions in mm (inch)

12.9 Hygienic encapsulated antenna (4" ISO 2852 sanitary clamp)

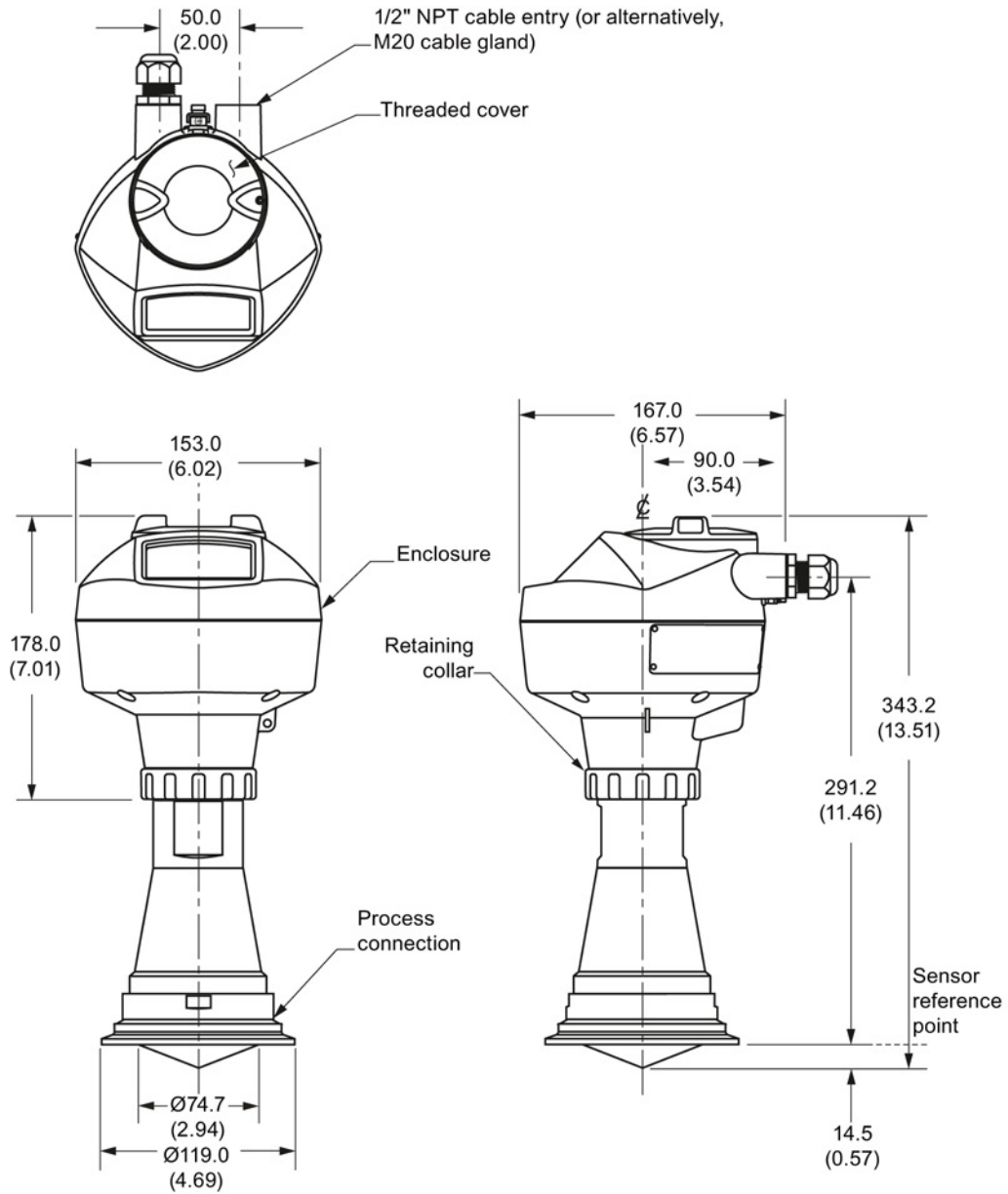

Dimensions in mm (inch)

12.10 Hygienic encapsulated antenna (DN 50 nozzle/slotted nut to DIN 11851)

12.10 Hygienic encapsulated antenna (DN 50 nozzle/slotted nut to DIN 11851)

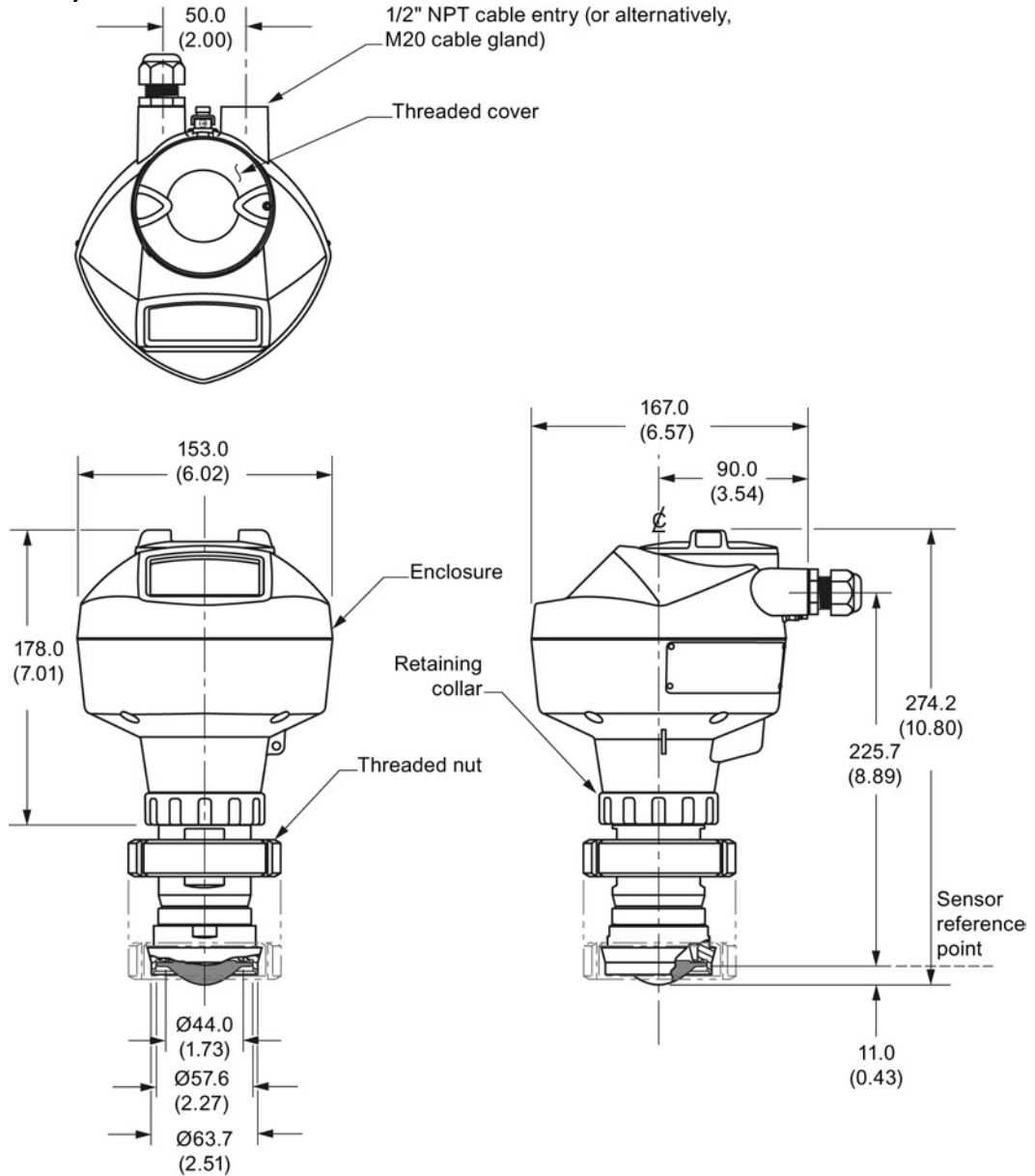

Dimensions in mm (inch)

Note

Cut out of process connection and placement of threaded nut are shown for illustration purposes only.

12.11 Hygienic encapsulated antenna (DN 80 nozzle/slotted nut to DIN 11851)

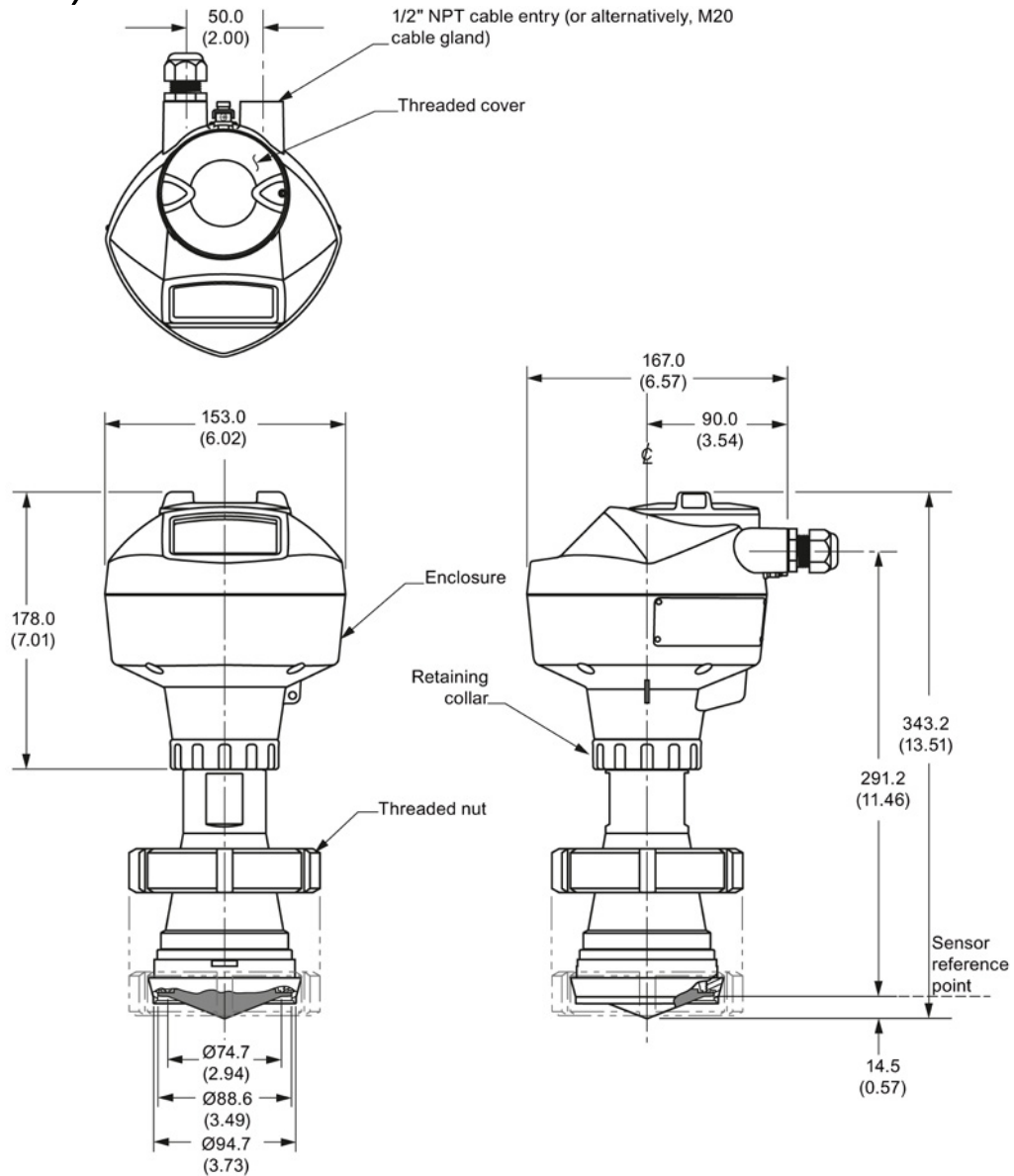

Dimensions in mm (inch)

Note

Cut out of process connection and placement of threaded nut are shown for illustration purposes only.

12.12 Hygienic encapsulated antenna (DN 100 nozzle/slotted nut to DIN 11851)

12.12 Hygienic encapsulated antenna (DN 100 nozzle/slotted nut to DIN 11851)

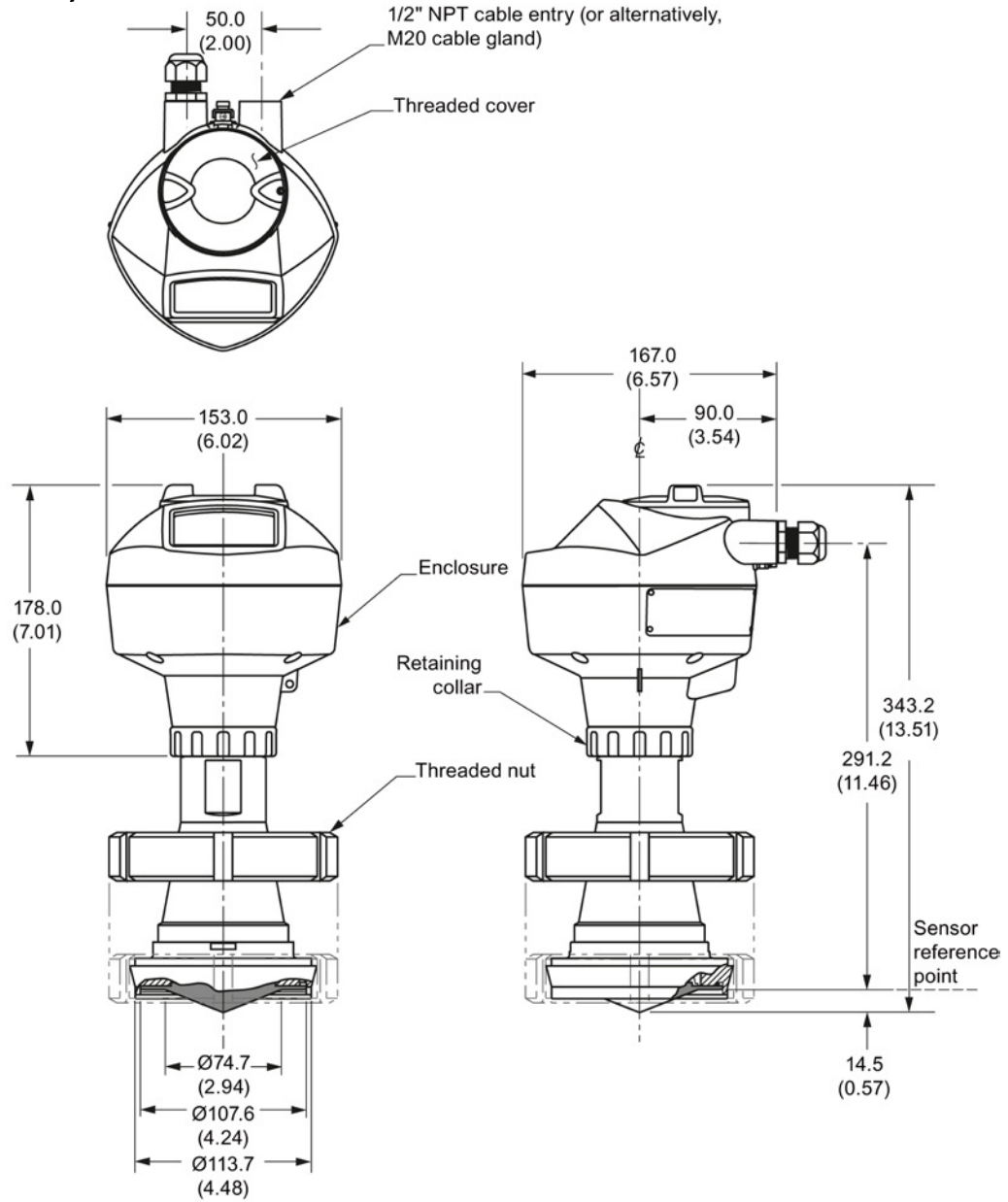

Dimensions in mm (inch)

Note

Cut out of process connection and placement of threaded nut are shown for illustration purposes only.

12.13 Hygienic encapsulated antenna (DN 50 aseptic slotted nut to DIN 11864-1)

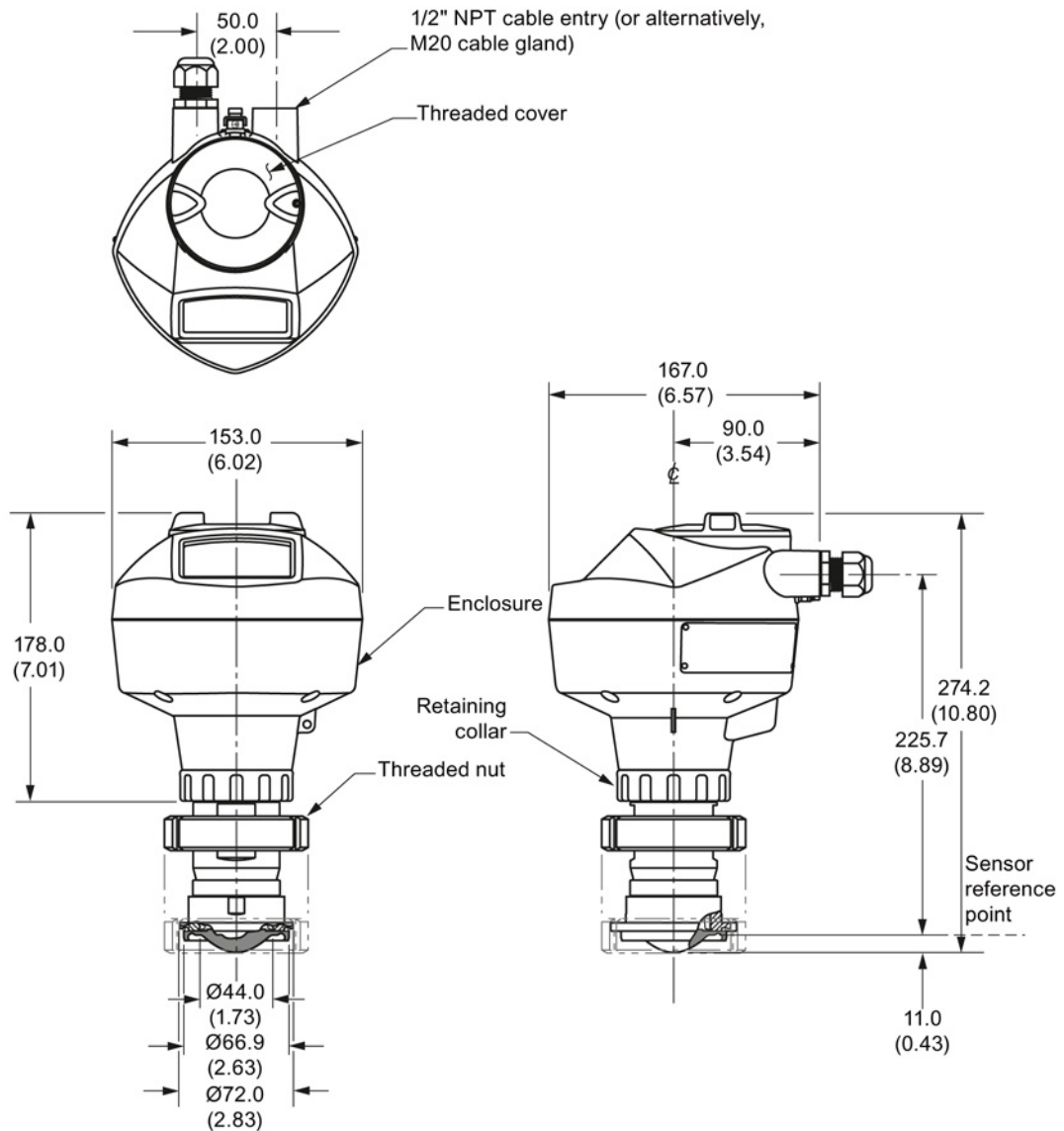

Dimensions in mm (inch)

Note

Cut out of process connection and placement of threaded nut are shown for illustration purposes only.

12.14 Hygienic encapsulated antenna (DN 80 aseptic slotted nut to DIN 11864-1)

12.14 Hygienic encapsulated antenna (DN 80 aseptic slotted nut to DIN 11864-1)

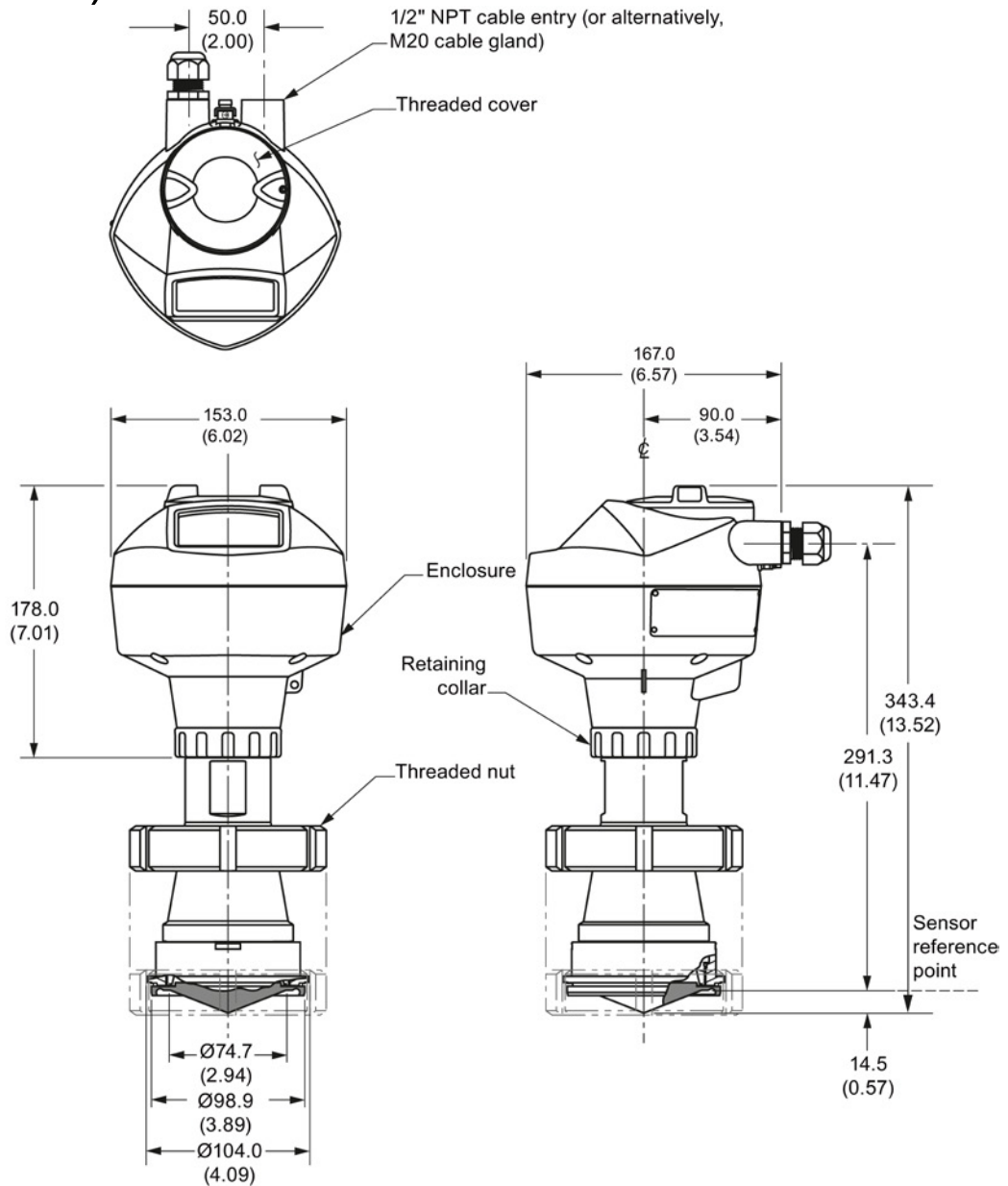

Dimensions in mm (inch)

Note

Cut out of process connection and placement of threaded nut are shown for illustration purposes only.

12.15 Hygienic encapsulated antenna (DN 100 aseptic slotted nut to DIN 11864- 1)

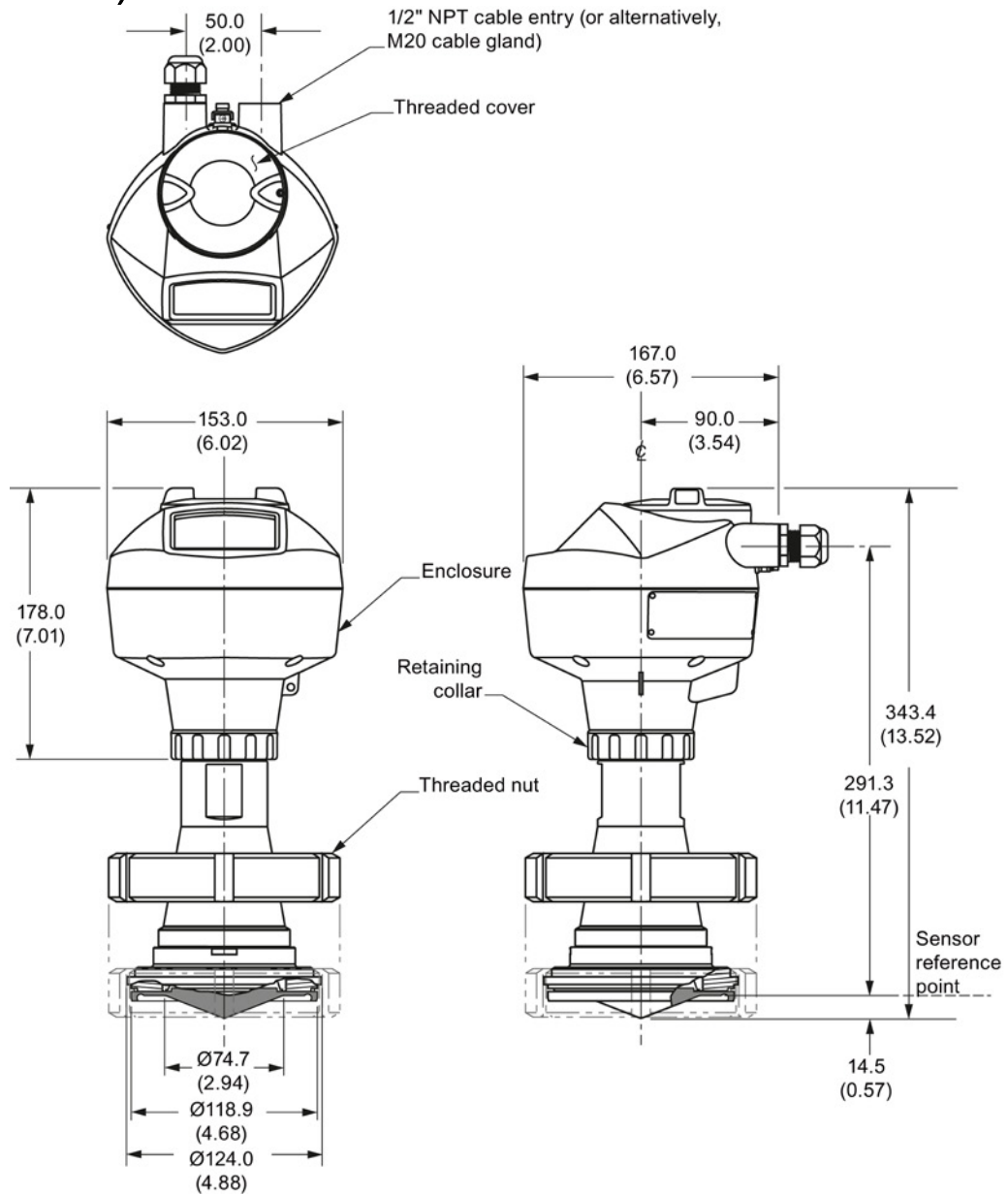

Dimensions in mm (inch)

Note

Cut out of process connection and placement of threaded nut are shown for illustration purposes only.

12.16 Hygienic encapsulated antenna (DN 50 aseptic flange to DIN 11864-2)

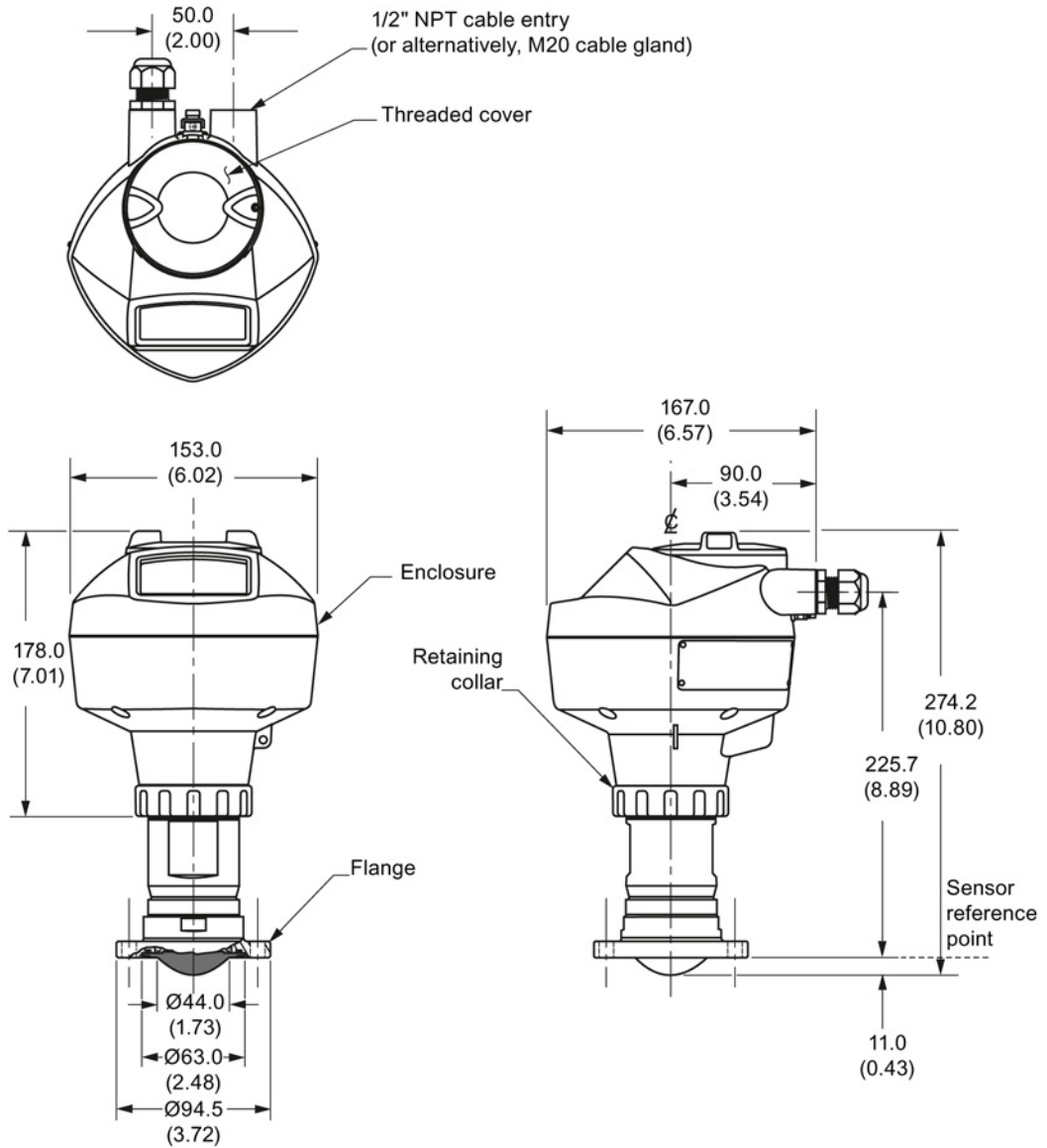

Dimensions in mm (inch)

Note

Cut out of process connection and flange are shown for illustration purposes only.

12.17 Hygienic encapsulated antenna (DN 80 aseptic flange to DIN 11864-2)

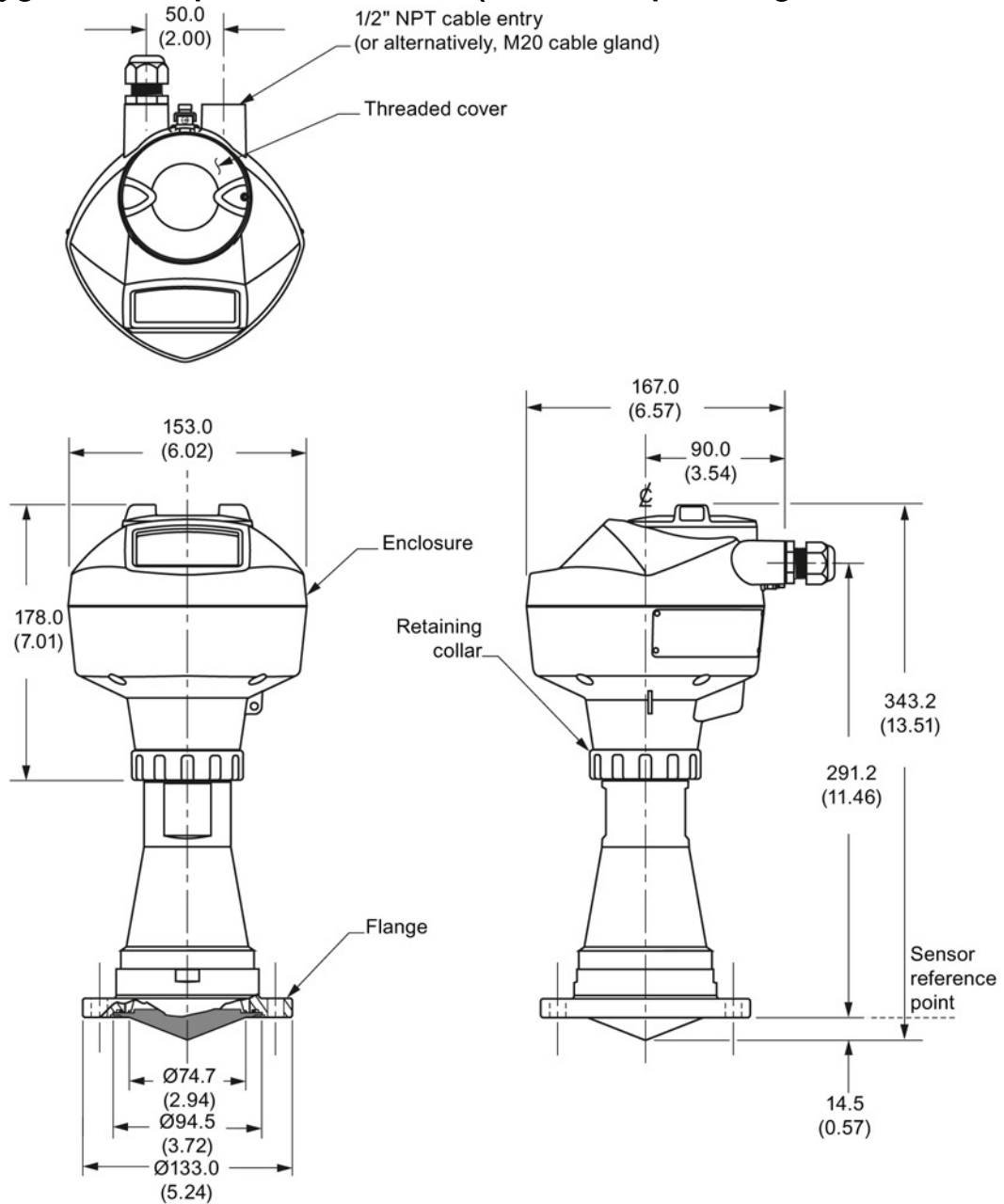

Dimensions in mm (inch)

Note

Cut out of process connection and flange are shown for illustration purposes only.

12.18 Hygienic encapsulated antenna (DN 100 aseptic flange to DIN 11864-2)

12.18 Hygienic encapsulated antenna (DN 100 aseptic flange to DIN 11864-2)

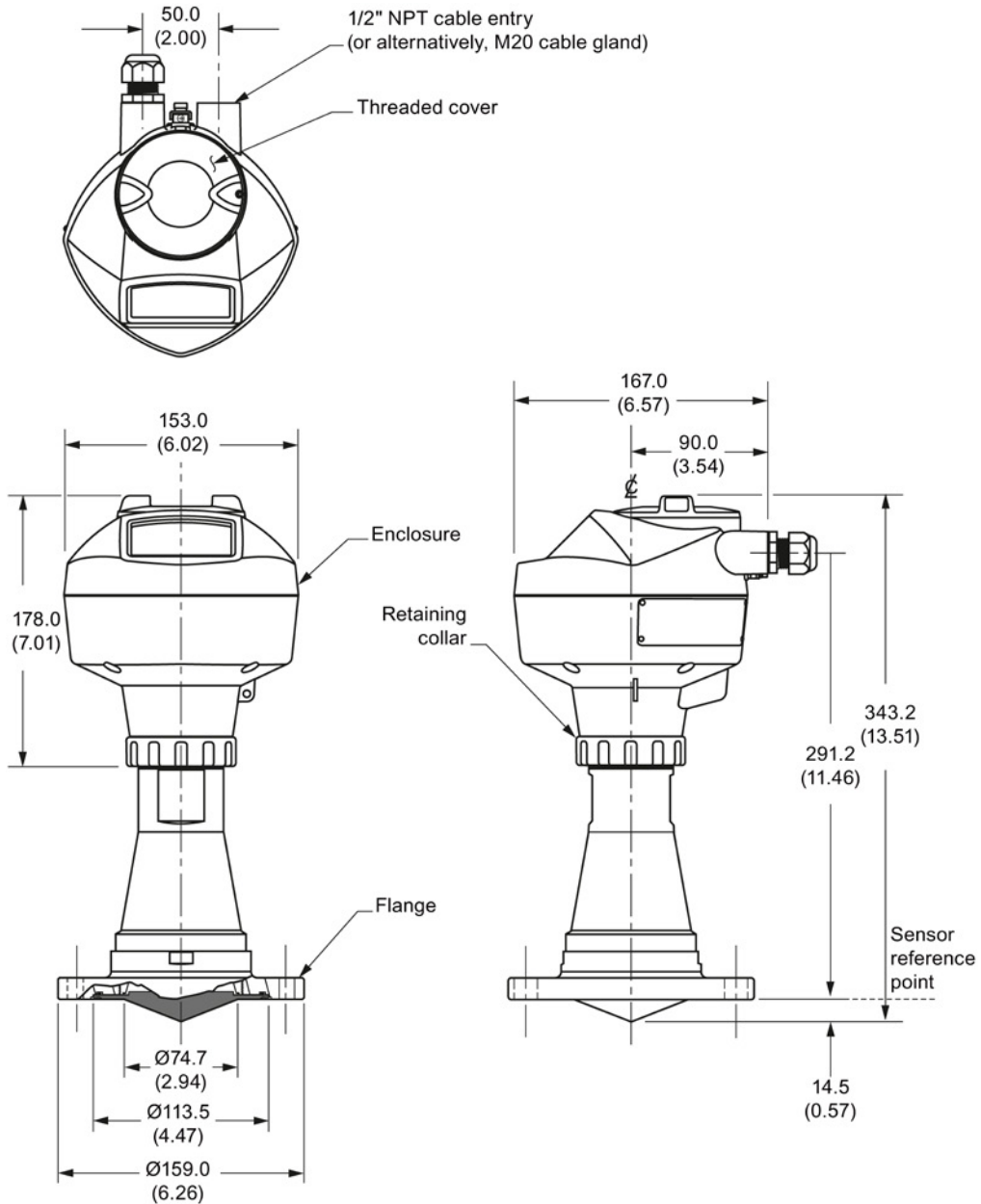

Dimensions in mm (inch)

Note

The cut out of the process connection and the flange are shown for illustration purposes only.

12.19 Hygienic encapsulated antenna (DN 50 aseptic clamp to DIN 11864-3)

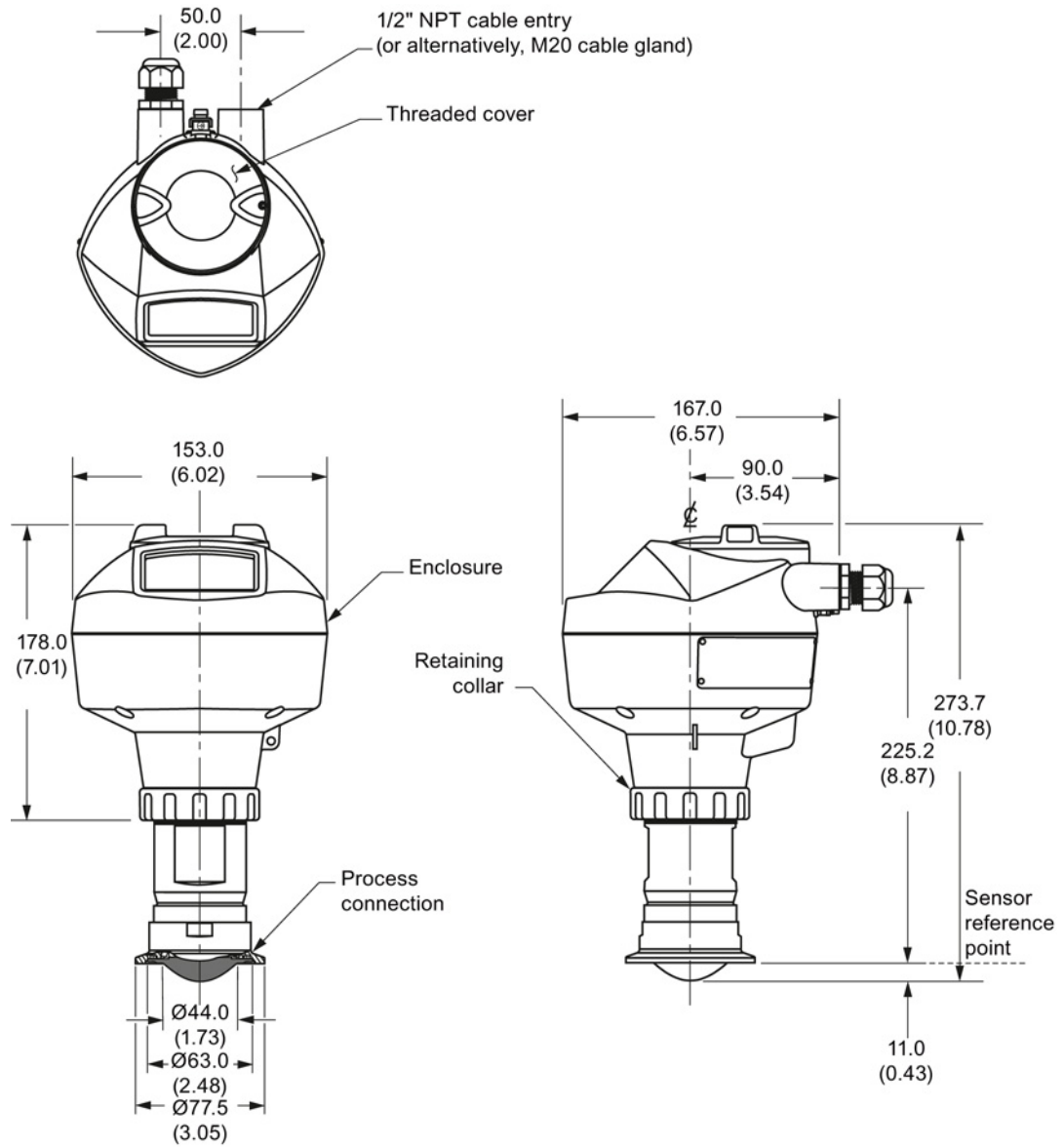

12.20 Hygienic encapsulated antenna (DN 80 aseptic clamp to DIN 11864-3)

Dimensions in mm (inch)

Note

Cut out of process connection is shown for illustration purposes only.

12.20 Hygienic encapsulated antenna (DN 80 aseptic clamp to DIN 11864-3)

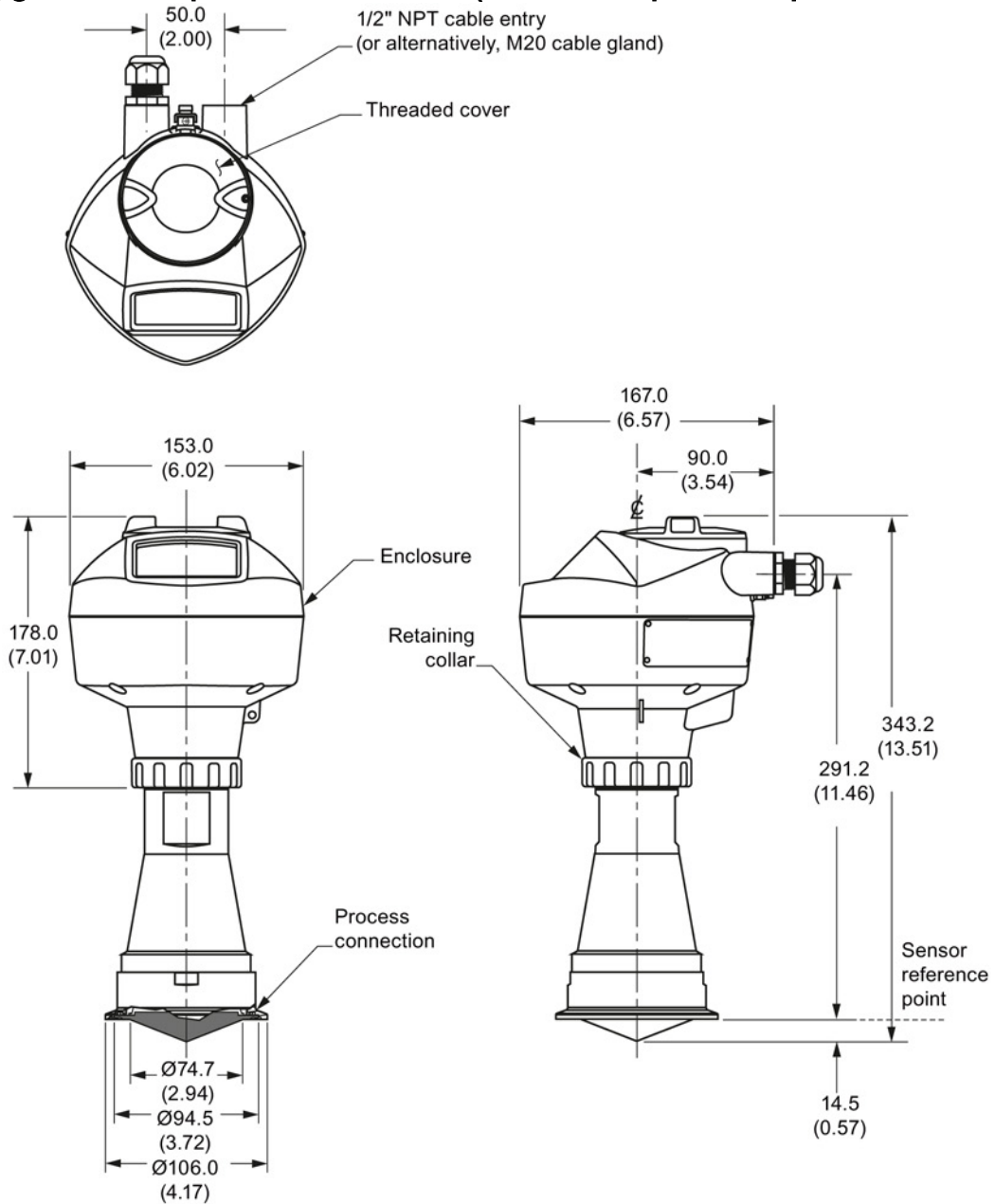

Dimensions in mm (inch)

Note

Cut out of process connection is shown for illustration purposes only.

12.21 Hygienic encapsulated antenna (DN 100 aseptic clamp to DIN 11864-3)

12.21 Hygienic encapsulated antenna (DN 100 aseptic clamp to DIN 11864-3)

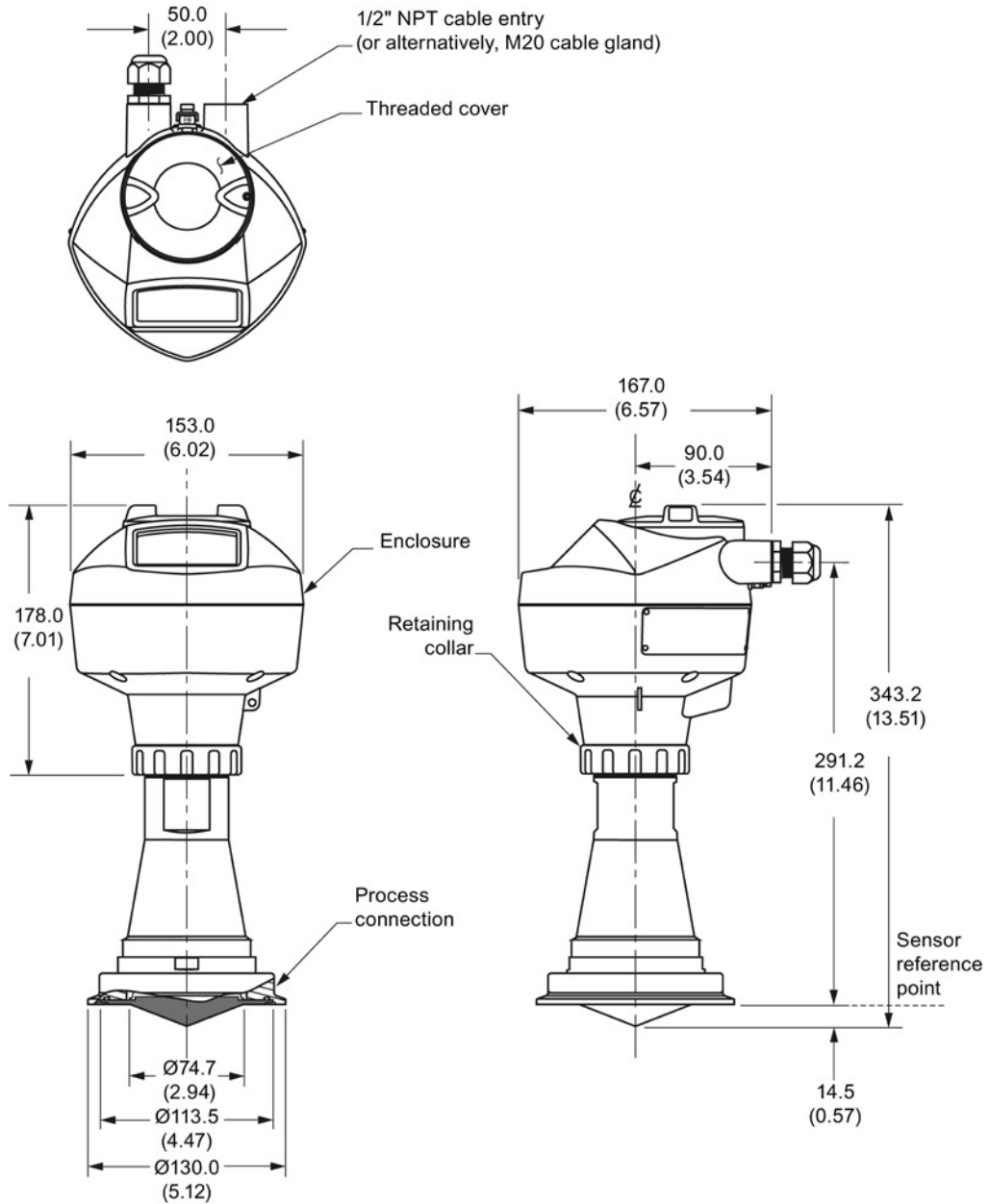

Dimensions in mm (inch)

Note

Cut out of process connection is shown for illustration purposes only.

12.22 Hygienic encapsulated antenna (Tuchenhagen Type N)

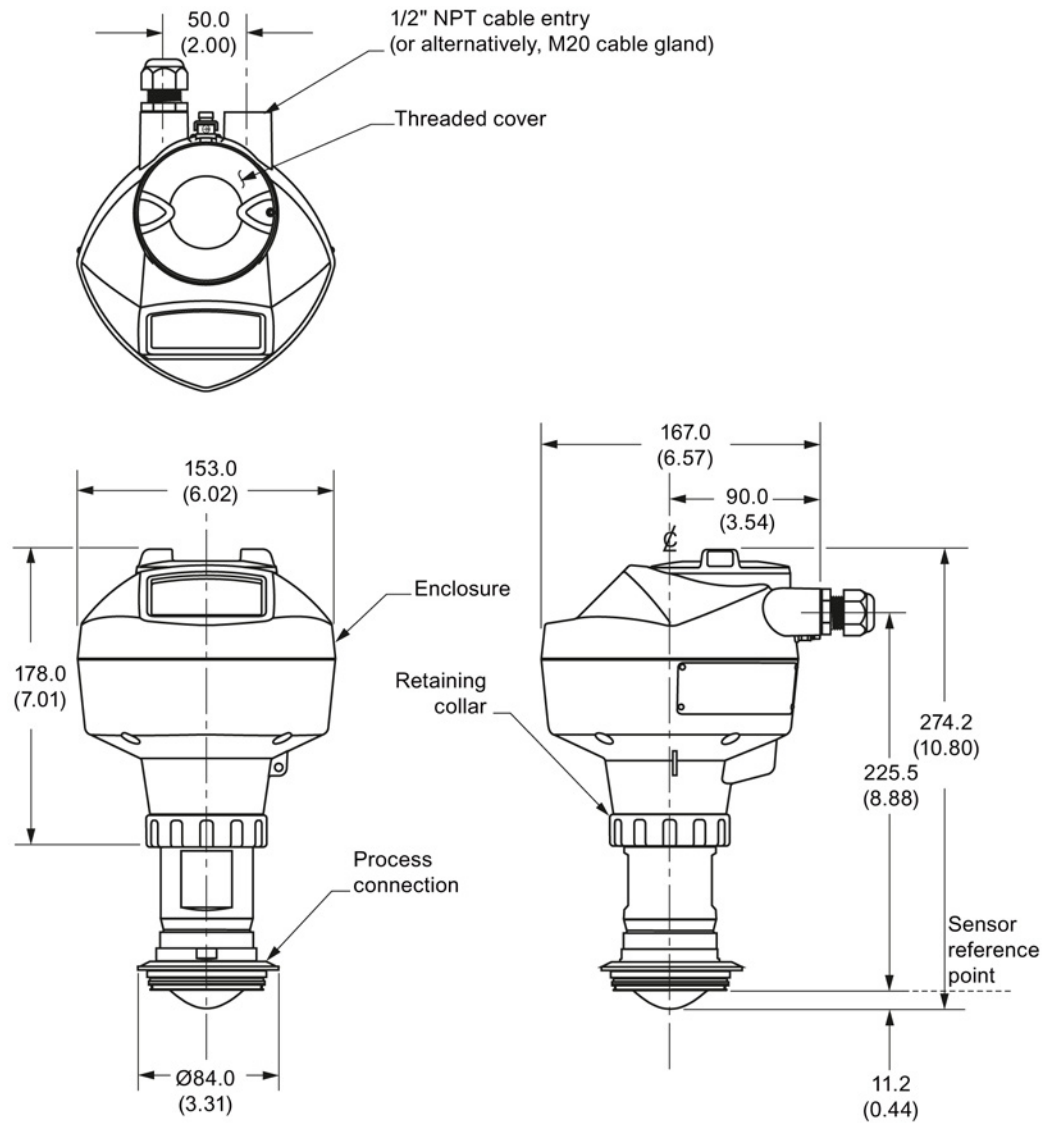

Dimensions in mm (inch)

12.23 Hygienic encapsulated antenna (Tuchenhagen Type F)

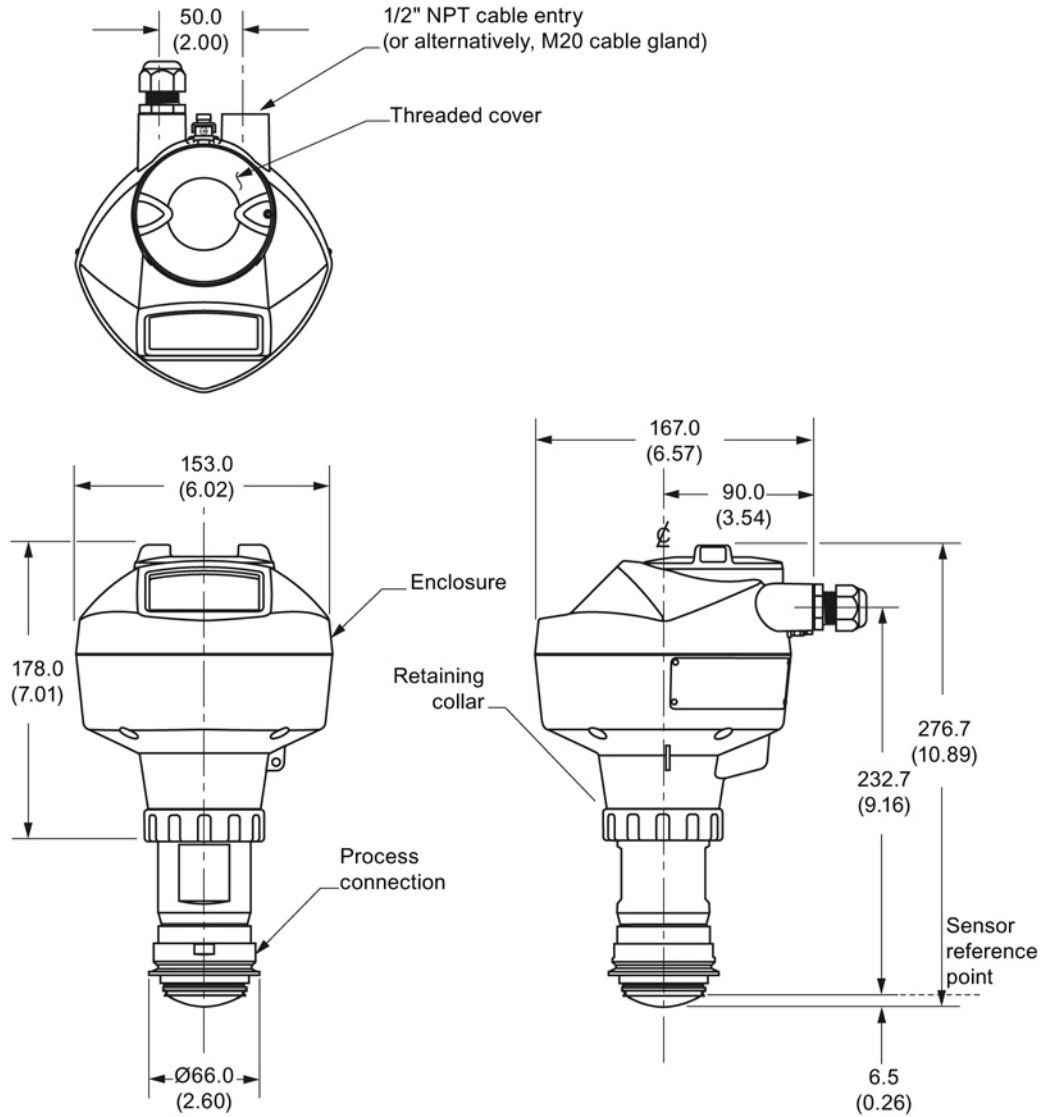

Dimensions in mm (inch)

12.24 Threaded PVDF antenna

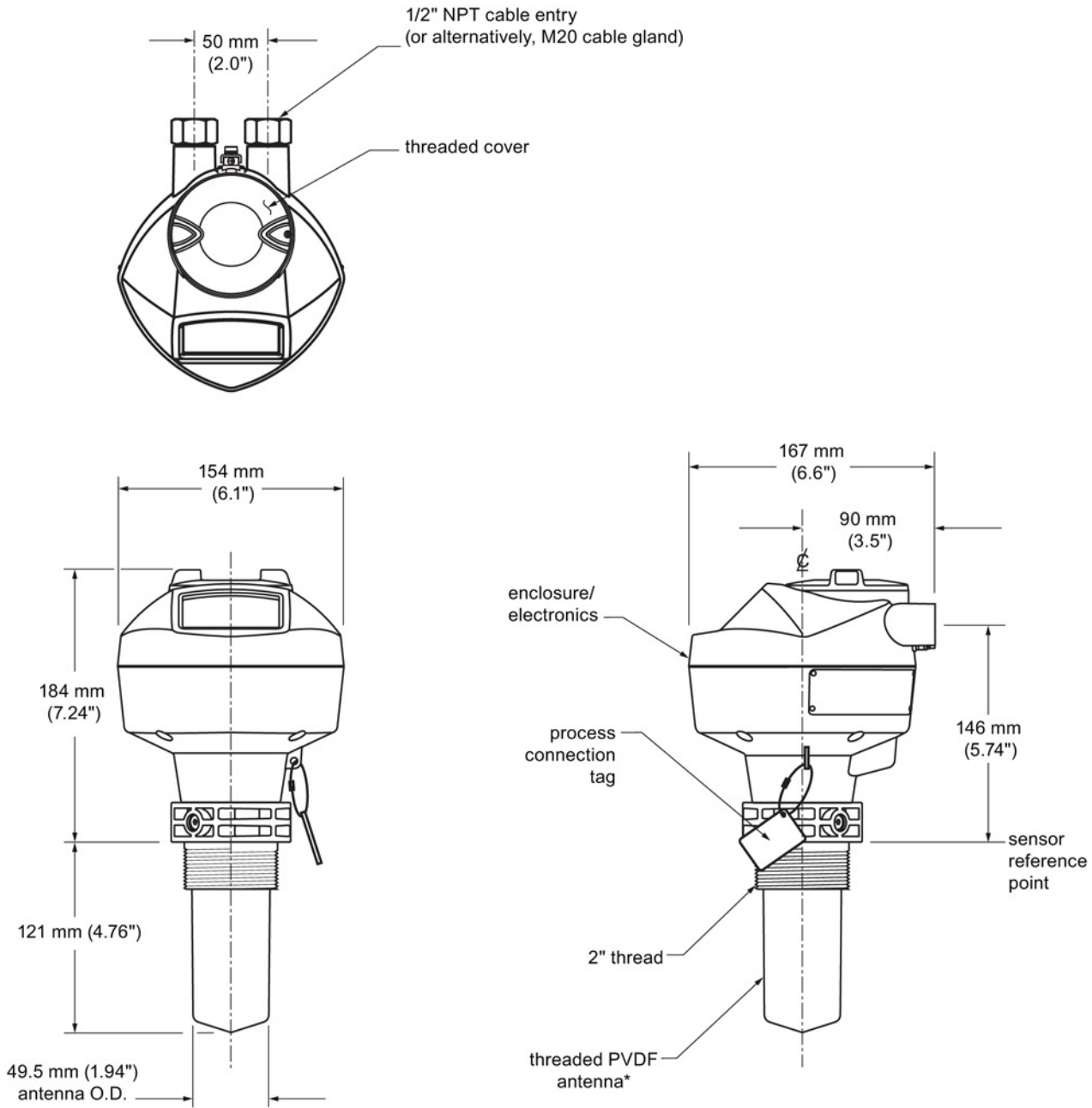

*The color of the antenna may vary.

Threaded PVDF antenna dimensions

Nominal antenna size	Antenna O.D.	Height to sensor reference point ^{a)}	Beam angle ^{b)}	Measurement range
50 mm (2")	49.5 mm (1.94")	121 mm (4.76")	19 degrees	10 m (32.8 ft) ^{c)}

a) Height from bottom of antenna to sensor reference point as shown: see dimension drawing.

b) -3dB in the direction of the polarization axis. See Polarization reference point (Page 31) for an illustration.

c) 20m when installed in stillpipe.

12.25 Threaded connection markings

With the exception of the threaded PVDF antenna, threaded connection markings are found on the flat face/faces of the process connection.

Serial number: a unique number allotted to each process connection, including the date of manufacture (MMDDYY) followed by a number from 001 to 999, (indicating the sequential unit produced).

12.26 Raised-Face flange per EN 1092-1 for flanged horn antenna

Stainless steel or optional alloy N06022/2.4602 (Hastelloy® C-22)

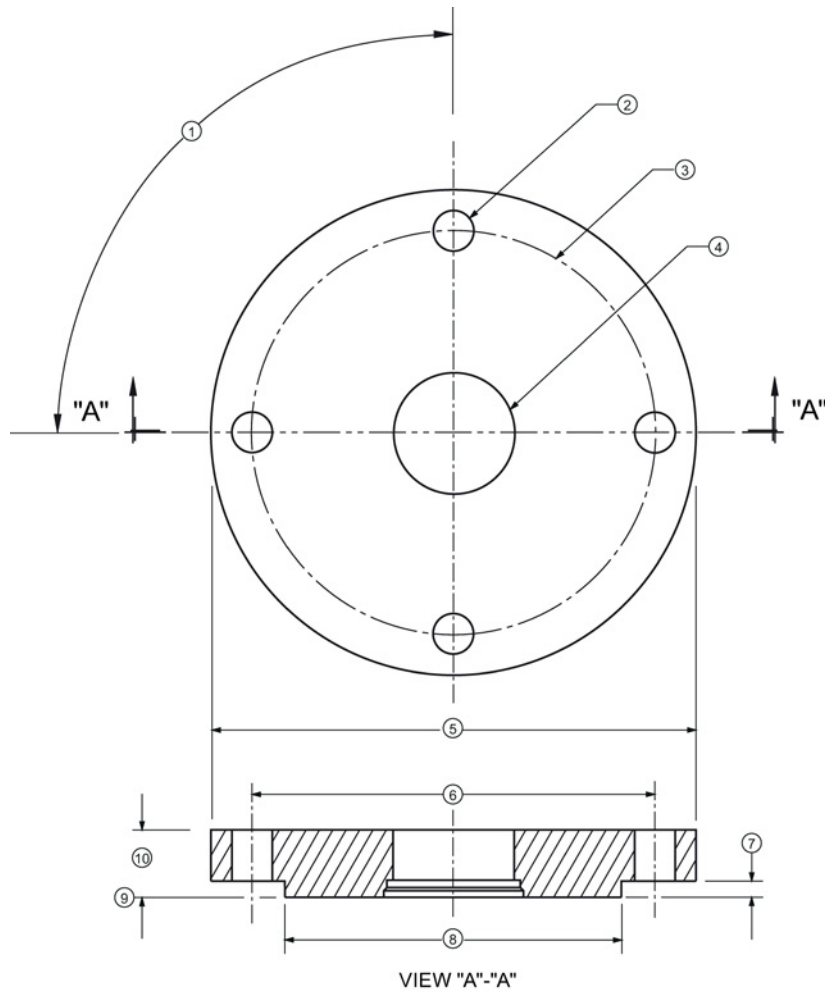

- | | | | |
|---|------------------------------|---|---------------------------|
| ① | angle of adjacent bolt holes | ⑥ | bolt hole circle diameter |
| ② | bolt hole diameter | ⑦ | facing height |
| ③ | bolt hole circle diameter | ⑧ | facing diameter |
| ④ | waveguide mounting hole | ⑨ | sensor reference point |
| ⑤ | Flange O.D. | ⑩ | thickness |

Raised-Face flange dimensions

Pipe size	Flange bolt hole pattern	⑤ Flange O.D. (mm)	③ Bolt hole circle Ø (mm)	② Bolt hole Ø (mm)	No. of bolts	① Angle of adjacent bolt holes	⑧ Facing Ø (mm)	⑩ Thickness (mm)
DN50	PN10/PN16	165	125	18	4	90	102	18
DN80	PN10/PN16	200	160	18	8	45	138	20
DN100	PN10/PN16	220	180	18	8	45	158	20
DN150	PN10/PN16	285	240	22	8	45	212	22
DN50	PN25/PN40	165	160	18	4	90	138	20
DN80	PN25/PN40	200	160	18	8	45	138	24
DN100	PN25/PN40	235	190	22	8	45	162	24
DN150	PN25/PN40	300	250	26	8	45	218	28

Raised-Face flange markings

Blind Flange Markings (Optional Manufacturer's Logo [optional]; Flange Standard; Nominal Size; Material; Heat Code)	Machining Identification			Welded Assembly Identification ^{a)}		
	Serial no.	Logo	Flange series	Flange series	Heat Code no.	Facing
Manufacturer's logo; EN 1092-1 05 'B1'; 'DN50' 'PN16' '1.4404 or 1.4435' A1B2C3	mmddyxx xx		xxxxx	xxxxx	A1B2C3	RF

^{a)} When flange material is alloy N06022/2.4602, additional material and heat code identification is provided.

The flange markings are located around the outside edge of the flange.

Serial number: a unique number allotted to each flange, including the date of manufacture (MMDDYY) followed by a number from 001 to 999 (indicating the sequential unit produced).

Flange series: the Siemens Milltronics drawing identification.

Heat code: a flange material batch code identification.

12.27 Raised-Face flange per EN 1092-1 for flanged encapsulated antenna

Stainless steel

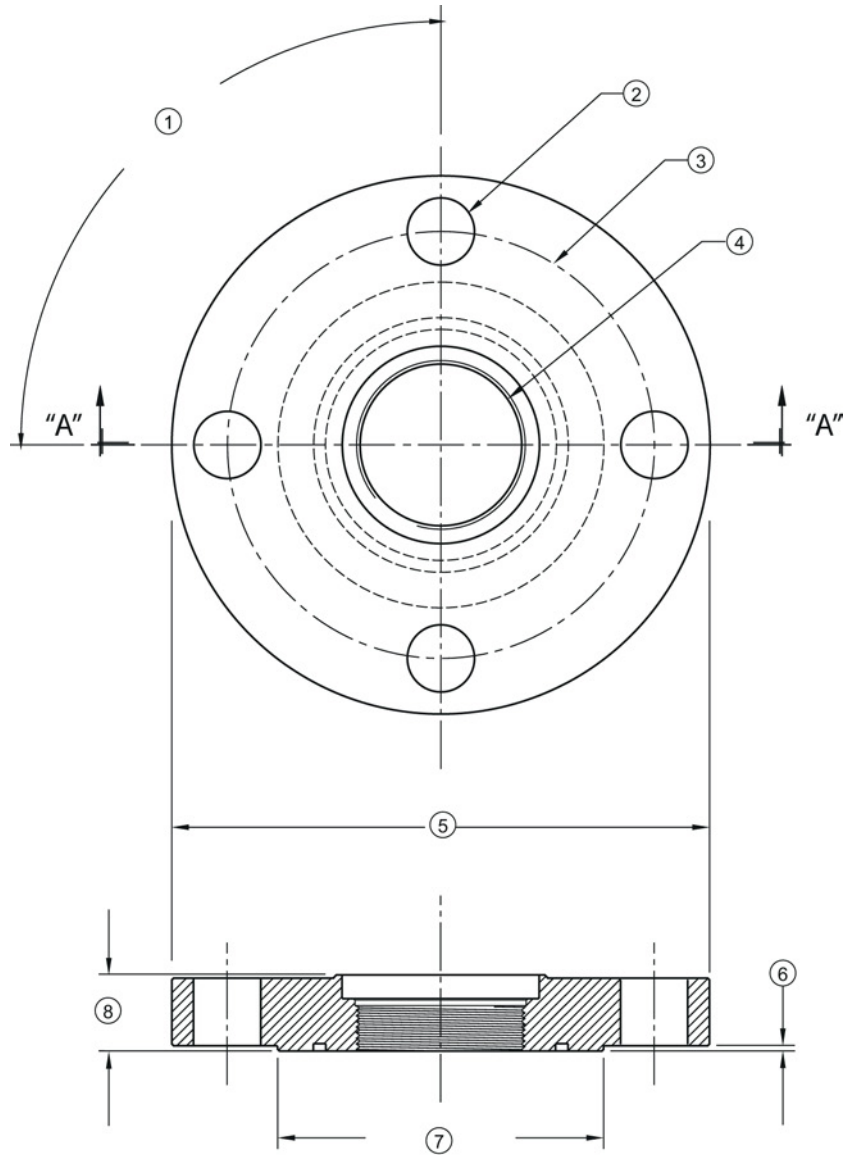

VIEW "A"- "A"

- | | | | |
|---|------------------------------|---|------------------|
| ① | angle of adjacent bolt holes | ⑤ | flange O.D. |
| ② | bolt hole diameter | ⑥ | facing height |
| ③ | bolt hole circle diameter | ⑦ | facing diameter |
| ④ | antenna | ⑧ | flange thickness |

12.27 Raised-Face flange per EN 1092-1 for flanged encapsulated antenna

Raised-Face flange dimensions

Pipe size	Flange class	⑤ Flange O.D. [mm (inch)]	③ Bolt hole circle Ø [mm (inch)]	② Bolt hole Ø [mm (inch)]	No. of bolt holes	① Angle of adjacent bolt holes	⑦ Facing Ø [mm (inch)]	⑨ Flange thickness [mm (inch)]	⑥ Flange facing thickness [mm (inch)]
2"	150 LB	152 (5.98)	120.7 (4.75)	19 (0.75)	4	90	92.1 (3.63)	20.6 (0.81)	1.5 (0.06)
3"		190 (7.48)	152.4 (6.00)				127 (5.00)	25.9 (1.02)	2 (0.08)
4"		230 (9.06)	190.5 (7.50)		8	45	157.2 (6.19)		2 (0.08)
6"		280 (11.02)	241.3 (9.50)	22.2 (0.87)			215.9 (8.50)	26.9 (1.06)	1.5 (0.06)
DN50	PN10/16	155 (6.10)	125 (4.92)	18 (0.71)	4	90	102 (4.02)	18 (0.71)	2 (0.08)
DN80		200 (7.87)	160 (6.30)		8	45	138 (5.43)	20 (0.79)	2 (0.08)
DN100		220 (8.66)	180 (7.09)				158 (6.22)		2 (0.08)
DN150		285 (11.22)	240 (9.45)	22 (0.87)			212 (8.35)	22 (0.87)	2 (0.08)
50A	10K	155 (6.10)	120 (4.72)	19 (0.75)	4	90	96 (3.78)	16 (0.63)	2 (0.08)
80A		185 (7.28)	150 (5.91)		8	45	126 (4.96)	18 (0.71)	2 (0.08)
100A		210 (8.27)	175 (6.89)				151 (5.94)		2 (0.08)
150A		280 (11.02)	240 (9.45)	23 (0.91)			212 (8.35)	22 (0.87)	2 (0.08)

Raised-Face flange markings

Blind Flange Markings (Optional Manufacturer's Logo [optional]; Flange Standard; Nominal Size; Material; Heat Code)	Machining Identification			Welded Assembly Identification		
	Serial no.	Logo	Flange series	Flange series	Heat Code no.	Facing
Manufacturer's logo; EN 1092-1 05 'B1'; 'DN50' 'PN16' '1.4404 or 1.4435' A1B2C3	mmddyxx xx		xxxxx	xxxxx	A1B2C3	RF

The flange markings are located around the outside edge of the flange.

Serial number: a unique number allotted to each flange, including the date of manufacture (MMDDYY) followed by a number from 001 to 999 (indicating the sequential unit produced).

Flange series: the Siemens Milltronics drawing identification.

Heat code: a flange material batch code identification.

12.28 Flat-Face flange

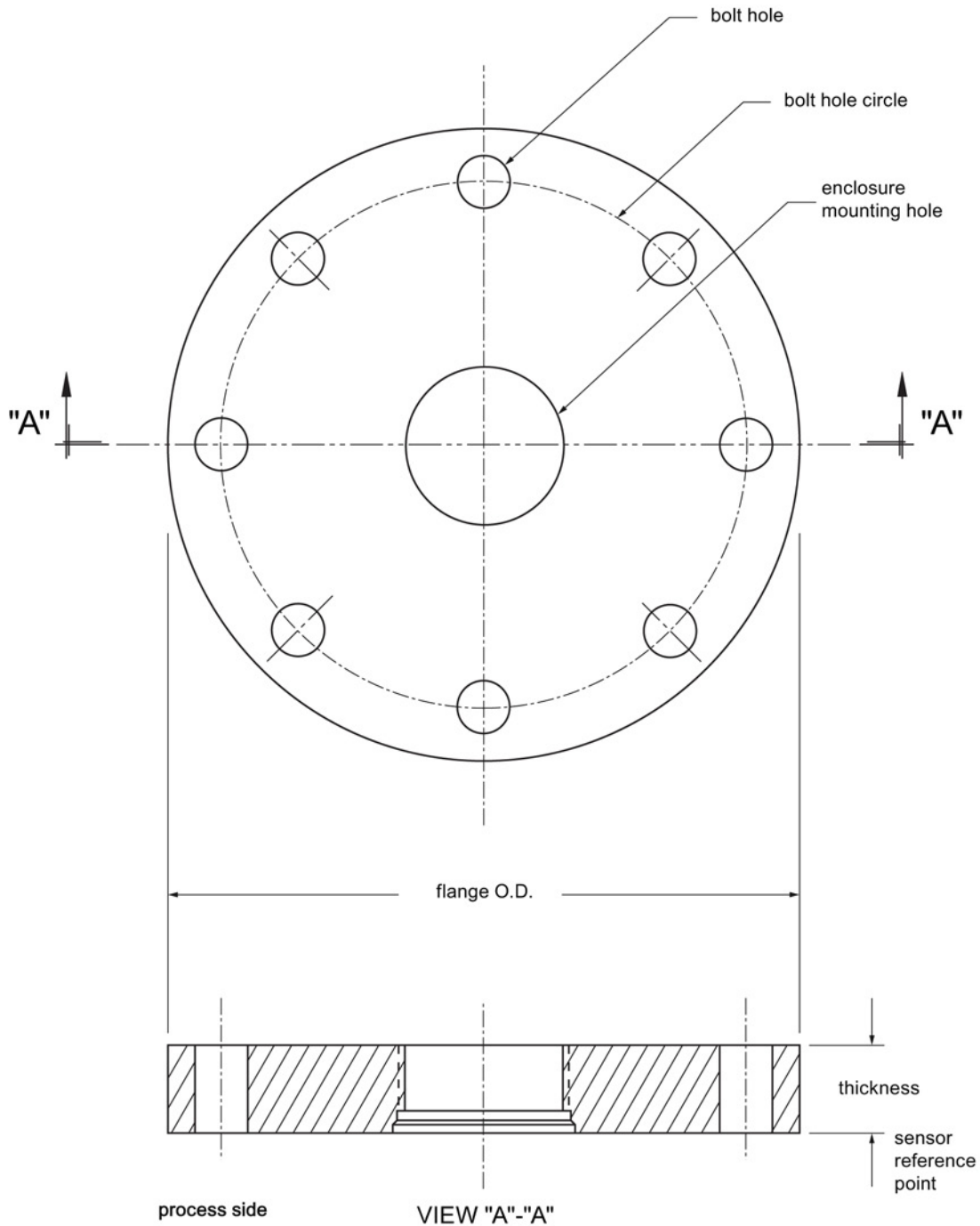

Flat-Face flange dimensions

Flange size ^{a)}	Flange class	Flange O.D.	Bolt hole circle Ø	Bolt hole Ø	No. of bolt holes	Thickness
2"	ASME 150 lb	6.0"	4.75"	0.75"	4	0.88"
3"	ASME 150 lb	7.5"	6.0"	0.75"	4	0.96"
4"	ASME 150 lb	9.0"	7.50"	0.75"	8	1.25"
2"	ASME 300 lb	6.50"	5.00"	0.75"	8	1.12"
3"	ASME 300 lb	8.25"	6.62"	0.88"	8	1.38"
4"	ASME 300 lb	10.00"	7.88"	0.88"	8	1.50"
DN50	EN PN16	165 mm	125 mm	18 mm	4	24.4 mm
DN80	EN PN16	200 mm	160 mm	18 mm	8	31.8 mm
DN100	EN PN16	220 mm	180 mm	18 mm	8	31.8 mm
DN50	EN PN40	165 mm	125 mm	18 mm	4	25.4 mm
DN80	EN PN40	200 mm	160 mm	18 mm	8	31.8 mm
DN100	EN PN40	235 mm	190 mm	22 mm	8	38.1 mm
50A	JIS 10K	155 mm	120 mm	19 mm	4	23.8 mm
80A	JIS 10K	185 mm	150 mm	19 mm	8	24.4 mm
100A	JIS 10K	210 mm	175 mm	19 mm	8	28.5 mm

^{a)} A 2" flange is designed to fit a 2" pipe: for actual flange dimensions see Flange O.D. Flange markings located around the outside edge of the flat faced flange identify the flange assembly on which the device is mounted.

Flat-Face flange markings

Flat Face Flange Identification					Welded Assembly Identification						
Serial No.	Logo	Flange series		Material	Heat code	Flange series	Heat code no.				
		Series	Nominal size								
MMDDYYXXX		25556	<table style="border-collapse: collapse; margin-left: 20px;"> <tr> <td style="border-bottom: 1px solid black; padding: 2px 10px;">2</td> <td style="padding: 2px 10px;">150</td> </tr> <tr> <td style="padding: 2px 10px;">DN80</td> <td style="padding: 2px 10px;">PN16</td> </tr> </table>	2	150	DN80	PN16	316L/ 1.4404 or 316L/ 1.4435	A1B2C3	25546	A1B2C3
2	150										
DN80	PN16										

Serial number: A unique number allotted to each flange, including the date of manufacture (MMDDYY) followed by a number from 001 to 999 (indicating the sequential unit produced).

Flange series: The Siemens Milltronics drawing identification.

Nominal size: The flange size followed by the hole pattern for a particular flange class. For example:

- A 2 inch ASME B16.5 150 lb class flange (North America)
- A DN80 EN 1092-1 PN16 class flange (Europe)

Material: The basic flange material (AISI or EU material designation). North American material codes are followed by European ones. For example, material designation 316L/1.4404.

Heat code: A flange material batch code identification.

12.29 Aseptic/hygienic flange DN50, DN80, DN100 for DIN 11864-2

Aseptic/hygienic flange DN50

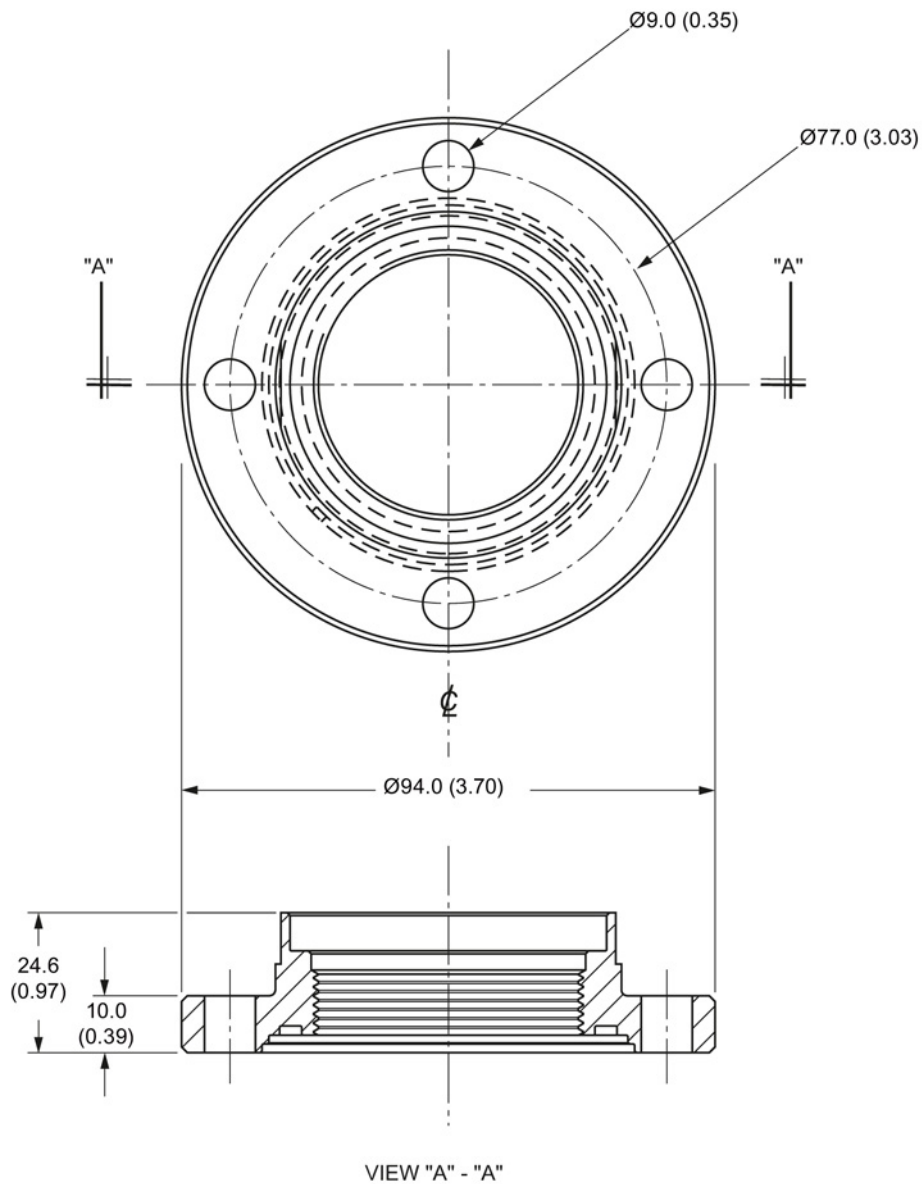

Dimensions in mm (inch)

Aseptic/hygienic flange DN80

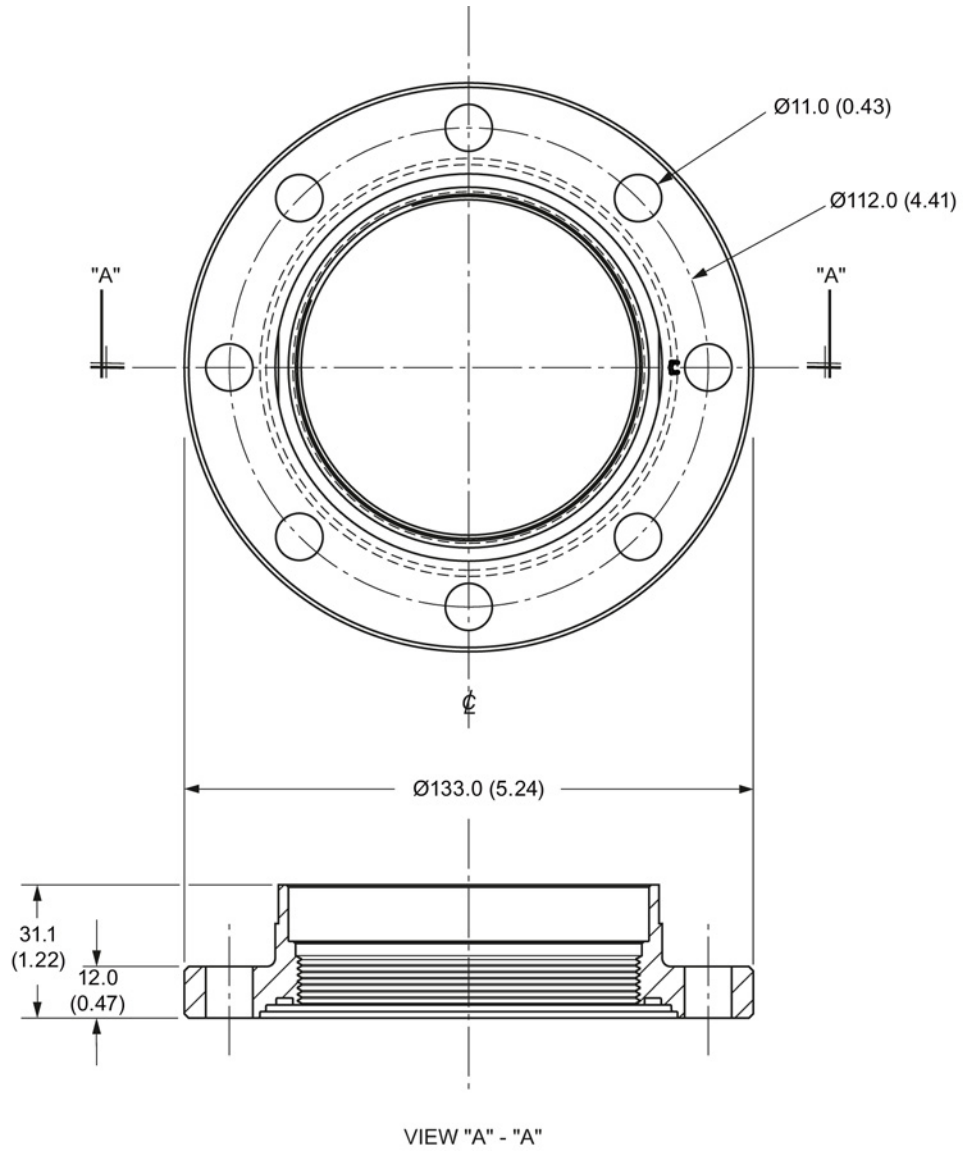

Dimensions in mm (inch)

Aseptic/hygienic flange DN100

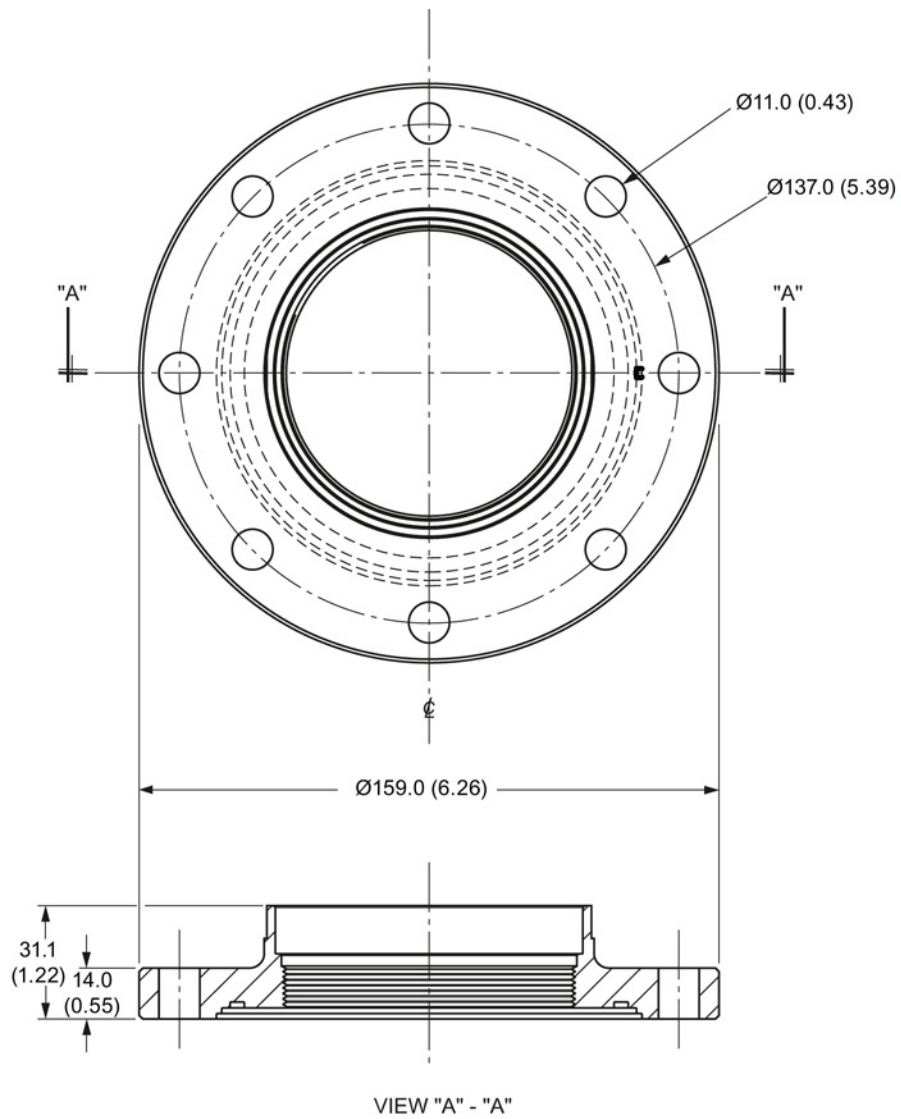

Dimensions in mm (inch)

12.30 Process connection tag (pressure rated versions)

For pressure-rated versions only, the process connection label lists the following information:

Process connection tag (pressure rated versions)

Item	Sample Text	Comments/Explanation
SERIAL #	GYZ / 00000000	Pressure Boundary Assembly
NOMINAL PIPE SIZE (DN)	4 INCH / 100mm	Nominal Pipe Size
INSTRUMENT MAWP (PS)	11.0 BAR	Maximum Allowable Working Pressure at Design Temperature for the device
DESIGN TEMP. (TS)	200 °C	Maximum Allowable Working Temperature
MINIMUM PROCESS	15.9 BAR AT 40 °C	Minimum Wetted Process Conditions
TEST PRESSURE (PT)	22.7 BAR	Production Test Pressure
TEST DATE	10/11/11	Date of Pressure Test (Year/Month/Day)
CONNECTION SERIES	ASME B16.5	Flange Series: dimensional pattern based on ASME B16.5 flange standards
PROCESS SERIES	25546	Pressure Tag Family Series
WETTED NON-METALLICS	TFM	Antenna Emitter
WETTED METALLICS	316L	Process Connection Material(s)
WETTED SEALS	FKM	Seal Material(s)

- Minimum Wetted Process Conditions: the minimum pressure and temperature to which the device assembly may be exposed in the process, and continue to provide a pressure-retaining function.
- Pressure Tag Family Series: the identification number used to indicate specific process connection information relating to operating conditions.
- For Flanged encapsulated antenna: this information is laser-etched on antenna body

BACK FACE	
Sample Text	Comments/Explanation
CRN 0Fxxxx.5	Canadian Registration Number (CRN)

Appendix A: Technical reference

Note

Where a number follows the parameter name [for example, **Master Reset (4.1.)**] this is the parameter access number via the handheld programmer. See Parameter Reference (Page 107) for a complete list of parameters.

A.1 Principles of operation

SITRANS LR250 is a 2-wire 25 GHz pulse radar level transmitter for continuous monitoring of liquids and slurries. (The microwave output level is significantly less than that emitted from cellular phones.) Radar level measurement uses the time of flight principle to determine distance to a material surface. The device transmits a signal and waits for the return echo. The transit time is directly proportional to the distance from the material.

Pulse radar uses polarized electromagnetic waves. Microwave pulses are emitted from the antenna at a fixed repetition rate, and reflect off the interface between two materials with different dielectric constants (the atmosphere and the material being monitored).

Electromagnetic wave propagation is virtually unaffected by temperature or pressure changes, or by changes in the vapor levels inside a vessel. Electromagnetic waves are not attenuated by dust.

SITRANS LR250 consists of an enclosed electronic circuit coupled to an antenna and process connection. The electronic circuit generates a radar signal (25 GHz) that is directed to the antenna.

The signal is emitted from the antenna, and the reflected echoes are digitally converted to an echo profile. The profile is analyzed to determine the distance from the material surface to the sensor reference point. See Dimension drawings (Page 195). This distance is used as a basis for the display of material level and mA output.

A.2 Echo processing

A.2.1 Process Intelligence

The signal processing technology embedded in Siemens radar level devices is known as **Process Intelligence**.

Process intelligence provides high measurement reliability regardless of the dynamically changing conditions within the vessel being monitored. The embedded Process Intelligence dynamically adjusts to the constantly changing material surfaces within these vessels.

Process Intelligence is able to differentiate between the true microwave reflections from the surface of the material and unwanted reflections being returned from obstructions such as seam welds or supports within a vessel. The result is repeatable, fast and reliable measurement. This technology was developed as result of field data gained over some twenty years from more than 1,000,000 installations in many industries around the world.

Higher order mathematical techniques and algorithms are used to provide intelligent processing of microwave reflection profiles. This "knowledge based" technique produces superior performance and reliability.

A.2.2 Echo Selection

Time Varying Threshold (TVT)

A Time Varying Threshold (TVT) hovers above the echo profile to screen out unwanted reflections (false echoes).

In most cases the material echo is the only one which rises above the default TVT.

In a vessel with obstructions, a false echo may occur. See Auto False Echo Suppression (Page 246) for more details.

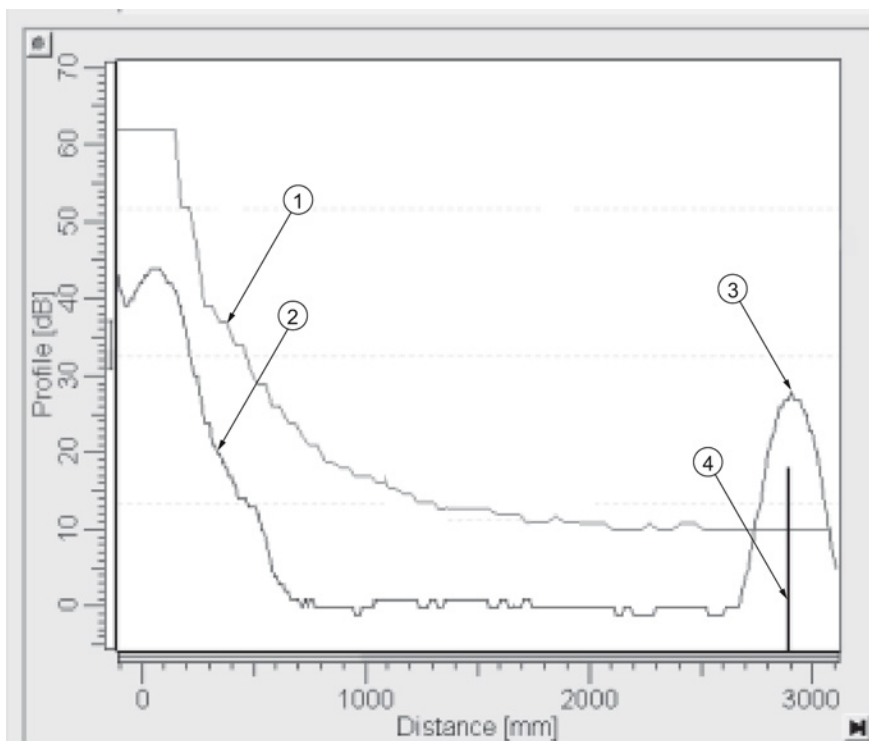

- ① default TVT
- ② echo profile
- ③ material level
- ④ echo marker

The device characterizes all echoes that rise above the TVT as potential good echoes. Each peak is assigned a rating based on its strength, area, height above the TVT, and reliability, amongst other characteristics.

Algorithm (2.5.7.1.)

The true echo is selected based on the setting for the Echo selection algorithm. Options are **true First Echo**, **Largest Echo**, or **best of First and Largest**.

Position Detect (2.5.7.2.)

The echo position detection algorithm determines which point on the echo will be used to calculate the precise time of flight, and calculates the range using the calibrated propagation velocity (see **Propagation Factor (2.5.3.)** for values). There are three options:

- **Center**
- **Hybrid**
- **CLEF** (Constrained Leading Edge Fit)

Center

Uses center of the echo.

Hybrid

Uses the Center algorithm for the top part of the vessel, and the CLEF algorithm for the part nearest the vessel bottom, according to the setting for **CLEF range**.

CLEF (Constrained Leading Edge Fit)

- Uses the leading edge of the echo.
- Is used mainly to process the echo from materials with a low dK value.

In an almost empty flat-bottomed vessel, a low dK material may reflect an echo weaker than the echo from the vessel bottom. The echo profile shows these echoes merging. The device may then report a material level equal to or lower than empty.

The CLEF algorithm enables the device to report the level correctly.

Example: CLEF off: Position set to Hybrid

Vessel height: 1.5 m; CLEF range set to 0 (**Center** algorithm gives the same result.)

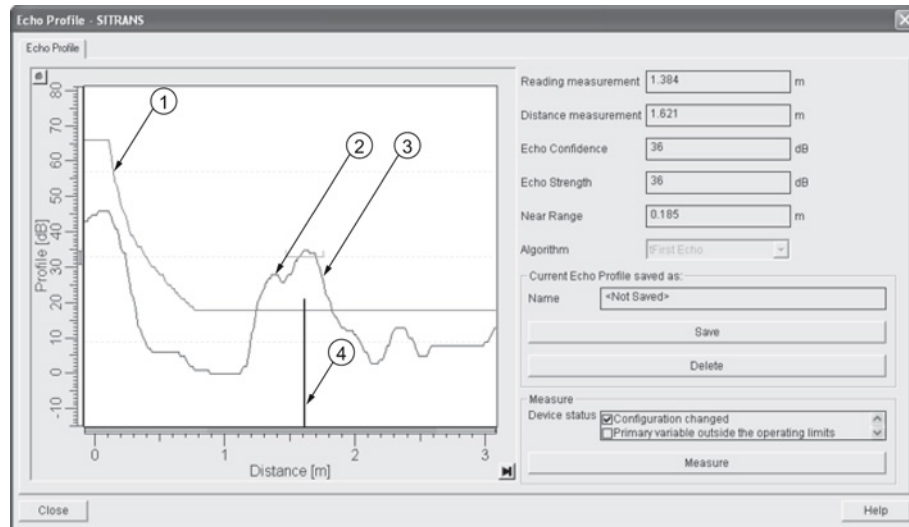

- ① default TVT
- ② material echo
- ③ vessel bottom echo selected
- ④ echo marker

Example: CLEF enabled

Vessel height: 1.5 m; CLEF range set to 0.5 m

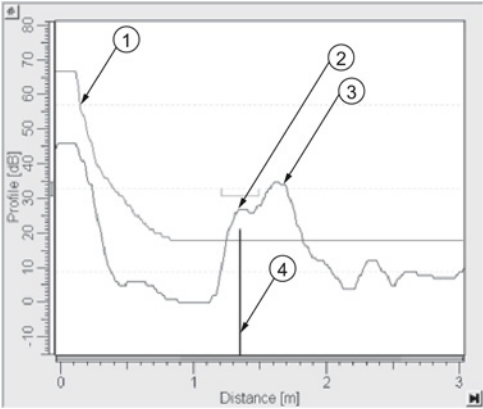

- ① default TVT
- ② material echo selected
- ③ vessel bottom echo
- ④ echo marker

A.2.3 CLEF Range

Determines the level below which the CLEF algorithm will be used. Above this level the Center algorithm is used when Hybrid is selected in **Position Detect (2.5.7.2.)**. CLEF Range is referenced from Low Calibration Point (process empty level).

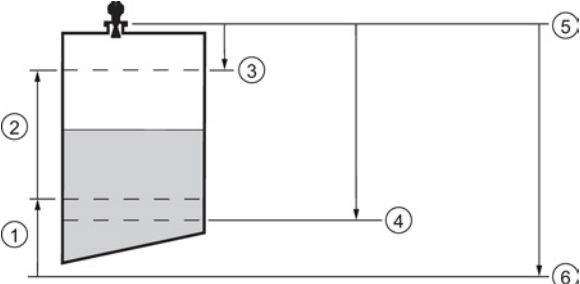

- ① CLEF range
- ② (Center algorithm applied)
- ③ High calibration point
- ④ Low calibration point
- ⑤ Sensor reference point
- ⑥ Low Calibration Point (process empty level)

A.2.4 Echo Threshold

Confidence (2.5.9.1.) describes the quality of an echo. Higher values represent higher quality. **Echo Threshold** defines the minimum confidence value required for an echo to be accepted as valid and evaluated.

A.2.5 Echo Lock

If the echo selected by **Algorithm** is within the Echo Lock window, the window is centered about the echo, which is used to derive the measurement. In radar applications, two measurement verification options are used:

Lock Off

SITRANS LR250 responds immediately to a new selected echo (within the restrictions set by the Maximum Fill / Empty Rate), but measurement reliability is affected.

Material Agitator

A new measurement outside the Echo Lock Window must meet the sampling criteria before the window will move to include it.

The other available options, **Maximum Verification** and **Total Lock** are not recommended for radar.

A.2.6 Auto False Echo Suppression

Note

- For detailed instructions on using this feature via PDM see Auto False Echo Suppression (Page 88).
 - For detailed instructions on using this feature via the handheld programmer see **Auto False Echo Suppression (2.5.10.1.)**.
-

Auto False Echo Suppression is designed to learn a specific environment (for example, a particular vessel with known obstructions), and in conjunction with Auto False Echo Suppression Range to remove false echoes appearing in front of the material echo.

The material level should be below all known obstructions at the moment when Auto False Echo Suppression learns the echo profile. Ideally the vessel should be empty or almost empty, and if an agitator is present, it should be running.

The device learns the echo profile over the whole measurement range and the TVT is shaped around all echoes present at that moment.

Auto False Echo Suppression Range (2.5.10.2.)

Auto False Echo Suppression Range specifies the range within which the learned TVT is applied. Default TVT is applied over the remainder of the range.

The learned TVT screens out the false echoes caused by obstructions. The default TVT allows the material echo to rise above it.

Auto False Echo Suppression Range must be set to a distance shorter than the distance to the material level when the environment was learned, to avoid the material echo being screened out.

Example before Auto False Echo Suppression

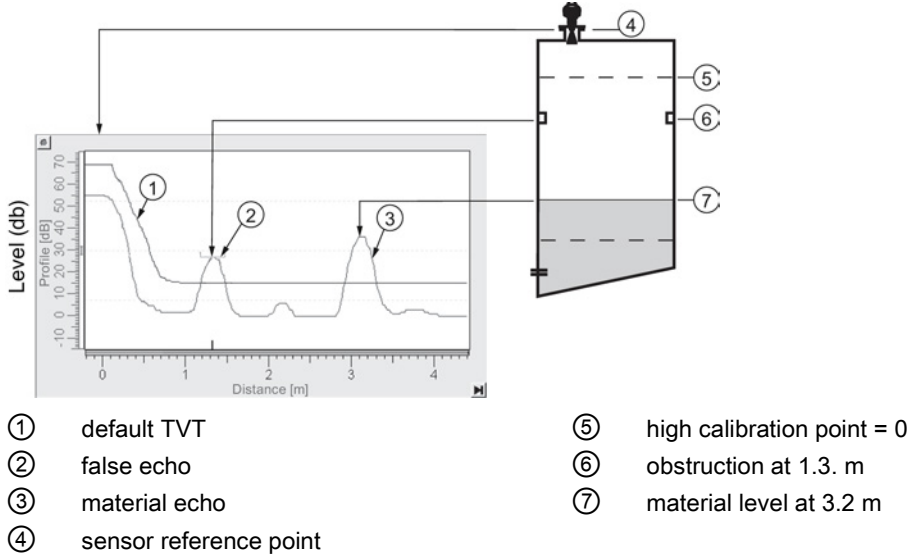

Example after Auto False Echo Suppression

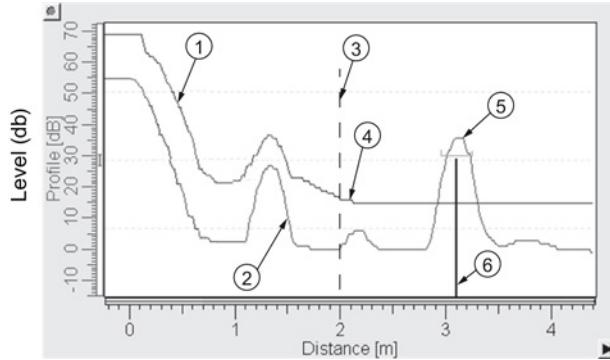

Auto False Echo
Suppression
Range set to 2 m

- | | | | |
|---|-----------------------------------|---|---------------|
| ① | Learned TVT | ④ | Default TVT |
| ② | False echo | ⑤ | Material echo |
| ③ | Auto False Echo Suppression Range | ⑥ | Echo marker |

A.2.7 Measurement Range

Near Range (2.5.1.)

Near Range programs SITRANS LR250 to ignore the zone in front of the antenna. The default blanking distance is 50 mm (1.97") from the end of the antenna.

Near Range allows you to increase the blanking value from its factory default. But **Auto False Echo Suppression (2.5.10.1.)** is generally recommended in preference to extending the blanking distance from factory values.

Far Range (2.5.2.)

Far Range can be used in applications where the base of the vessel is conical or parabolic. A reliable echo may be available below the vessel empty distance, due to an indirect reflection path.

Increasing Far Range to 30% or 40% can provide stable empty vessel readings.

A.2.8 Measurement Response

Note

Units are defined in **Units (2.3.1.)** and are in meters by default.

Response Rate (2.3.8.1) limits the maximum rate at which the display and output respond to changes in the measurement. There are three preset options: slow, medium, and fast.

Once the real process fill/empty rate (m/s by default) is established, a response rate can be selected that is slightly higher than the application rate. Response Rate automatically adjusts the filters that affect the output response rate.

Response Rate (2.3.8.1)		Fill Rate (2.3.8.2)/Empty Rate (2.3.8.3)	
*	Slow	0.1 m/min (0.32 ft/min)	10 s
	Medium	1.0 m/min (3.28 ft.min)	10 s
	Fast	10.0 m/min (32.8 ft/min)	0 s

A.2.9 Damping

Filter Time Constant (2.6.8.1) smooths out the response to a sudden change in level. This is an exponential filter and the engineering unit is always in seconds.

In 5 time constants the output rises exponentially: from 63.2% of the change in the first time constant, to almost 100% of the change by the end of the 5th time constant.

Damping example

time constant = 2 seconds
input (level) change = 2 m

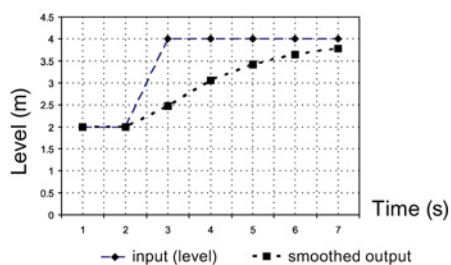

A.2.10 Loss of Echo (LOE)

A loss of echo (LOE) occurs when the calculated measurement is judged to be unreliable because the echo confidence value has dropped below the echo confidence threshold.

Confidence (2.5.9.1.) describes the quality of an echo. Higher values represent higher quality.

Echo Threshold (2.5.7.3.) defines the minimum confidence value required for an echo to be accepted as valid and evaluated.

If the LOE condition persists beyond the time limit set in **LOE Timer (2.3.6.)** the LCD displays the Service Required icon, and the text region displays the fault code **S: 0** and the text **LOE**.

If two faults are present at the same time, the fault code, error text, and error icon for each fault are displayed alternately. For example, Loss of Echo and faulty power supply:



Upon receiving a reliable echo, the loss of echo condition is aborted, the Service Required icon and error message are cleared, and the reading returns to the current level.

A.2.10.1 LOE Timer

LOE Timer (2.3.6.) determines the length of time a Loss of Echo (LOE) condition will persist before a Fail-safe state is activated. The default is 100 seconds. Fail-safe Mode determines the level to be reported when the Fail-safe timer expires.

A.2.10.2 Fail-safe Behavior

The purpose of the Fail-safe setting is to put the process into a safe mode of operation in the event of a fault or failure. The value to be reported in the event of a fault is selected so that a loss of power or loss of signal triggers the same response as an unsafe level.

Fail-safe mode may be triggered by a loss of echo, a bad configuration, or certain device faults. You can select one of three possible values to be reported when a Fail-safe mode is activated.

Mode

Mode (2.6.9.1.) determines the material level to be reported when **LOE Timer (2.3.6.)** expires.

Mode (2.6.9.1.)		
SUB VALUE		Use substitute value. Value (2.6.9.2.) used as output value.
LAST VALUE	*	Last value (Store last valid output value).
USE BAD VALUE		Use bad value (Calculated output value is incorrect).

Value

Value (2.6.9.2.) defines the material level to be reported if the option **Use substitute value** is selected in **Mode (2.6.9.1.)**.

The two Analog Input Function blocks are set separately.

To set a user-defined value

- Navigate to the Level Meter > Setup > desired Analog Input (1 or 2).
- Set **Mode (2.6.9.1.)** to **Use substitute value**.
- Go to **Value (2.6.9.2.)** and enter the desired value.

A.3 Maximum Process Temperature Chart

WARNING

Exceeded maximum internal and process temperatures

Danger of device malfunction

- Internal temperature must not exceed +80 ° C (+176 °F).
- Process temperature must not exceed limits specified by the antenna type.

Note

- The chart below is for guidance only.
- The chart does not represent every possible process connection arrangement. For example, it will NOT apply if you are mounting SITRANS LR250 directly on a metallic vessel surface.
- The chart does not take into consideration heating from direct sunlight exposure.

Maximum Process Temperatures versus allowable ambient

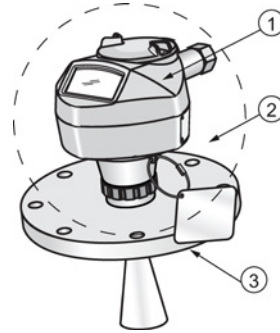
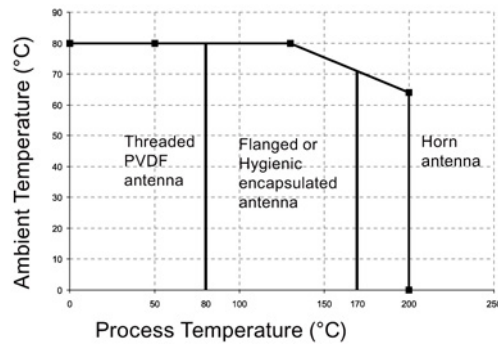

- ① Internal enclosure temperature
- ② Ambient temperature
- ③ Process temperature (at process connection)

Where the chart does not apply, please use your own judgement regarding the use of SITRANS LR250.

If the internal temperature exceeds the maximum allowable limit, a sun shield or a longer nozzle may be required.

See **Minimum Value (3.3.1.)** and **Maximum Value (3.3.2.)** to monitor the Internal Temperature.

A.4 Process Pressure/Temperature Derating Curves

WARNING

- Never attempt to loosen, remove or disassemble process connection or device housing while vessel contents are under pressure.
- Materials of construction are chosen based on their chemical compatibility (or inertness) for general purposes. For exposure to specific environments, check with chemical compatibility charts before installing.
- The user is responsible for the selection of bolting and gasket materials which will fall within the limits of the flange and its intended use and which are suitable for the service conditions.
- Improper installation may result in loss of process pressure and/or release of process fluids and/or gases.

Note

- The process connection tag shall remain with the process pressure boundary assembly. (The process pressure boundary assembly comprises the components that act as a barrier against pressure loss from the process vessel: that is, the combination of process connection body and emitter, but normally excluding the electrical enclosure). In the event the device package is replaced, the process connection tag shall be transferred to the replacement unit.
- SITRANS LR250 units are hydrostatically tested, meeting or exceeding the requirements of the ASME Boiler and Pressure Vessel Code and the European Pressure Equipment Directive.
- The serial numbers stamped in each process connection body, (flange, threaded, or sanitary), provide a unique identification number indicating date of manufacture. Example: MMDDYY – XXX (where MM = month, DD = day, YY = year, and XXX= sequential unit produced)
- Further markings (space permitting) indicate flange configuration, size, pressure class, material, and material heat code.

Pressure Equipment Directive, PED, 97/23/EC

Siemens Level Transmitters with flanged, threaded, or sanitary clamp type process mounts have no pressure-bearing housing of their own and, therefore, do not come under the Pressure Equipment Directive as pressure or safety accessories (see EU Commission Guideline 1/8 and 1/20).

A.4.1 Horn antenna

1.5", 2" and 3" [NPT, G (BSPP), R (BSPT)] Threaded Versions

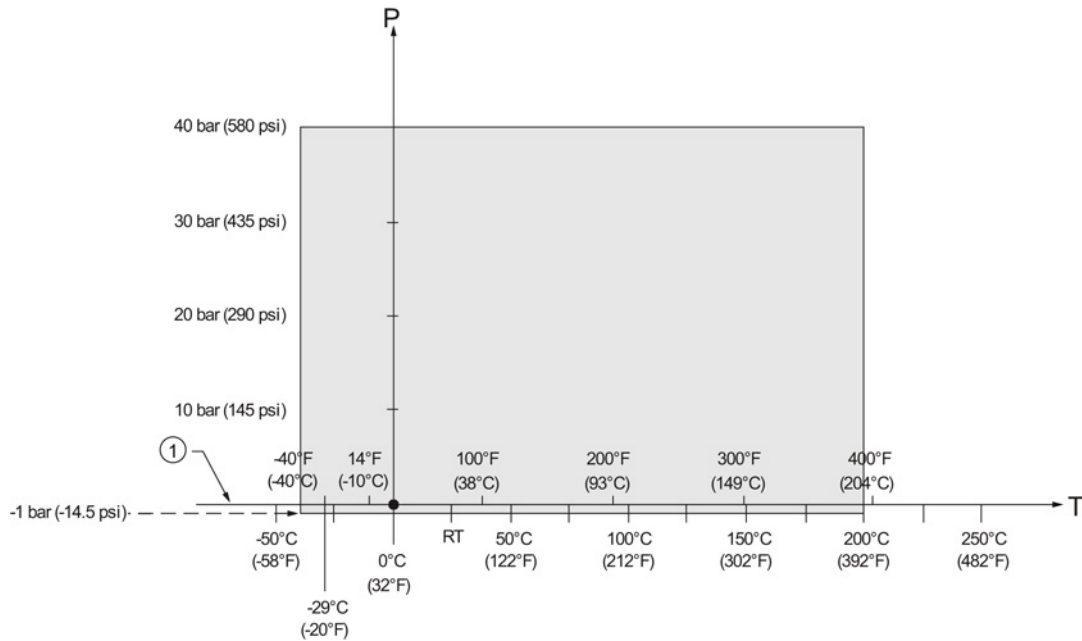

- ① Atmospheric
- P Allowable operating pressures
- T Allowable operating temperatures

A.4.2 Flanged horn antenna

JIS B 2220, 10K: 50A, 80A, and 100A

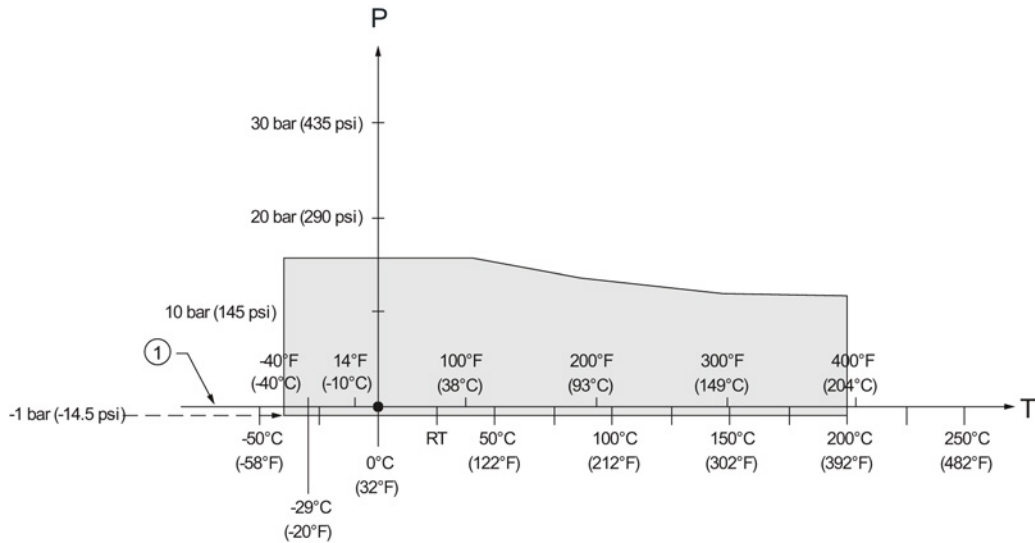

- ① Atmospheric
- P Allowable operating pressures
- T Allowable operating temperatures

EN1092-1, PN16: DN50, DN80, DN100, and DN150

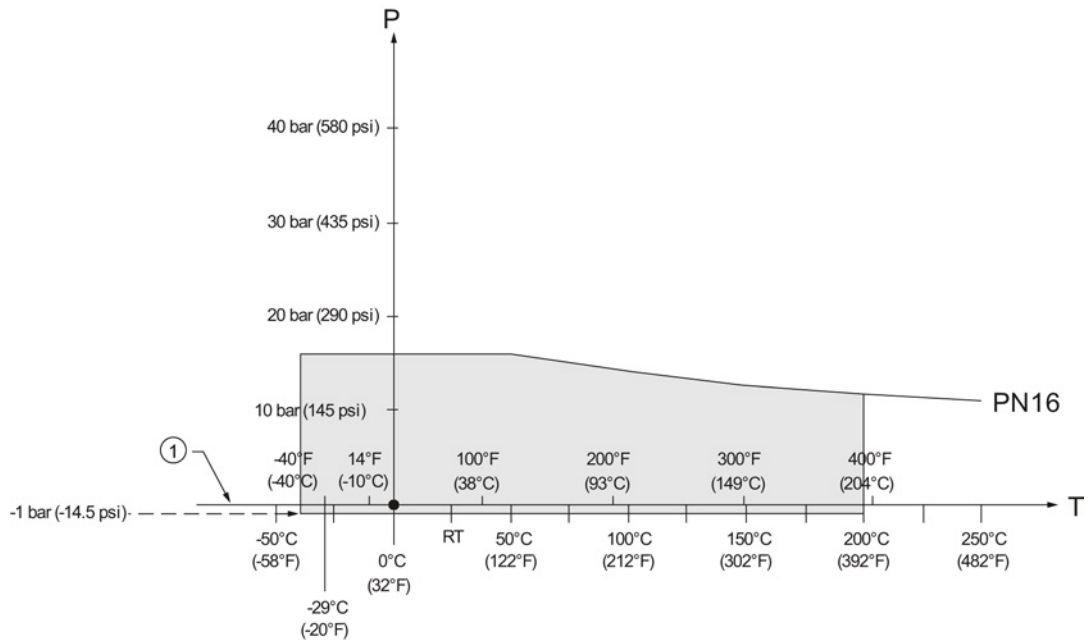

- ① Atmospheric
- P Allowable operating pressures
- T Allowable operating temperatures

EN1092-1, PN40: DN50, DN80, DN100, and DN150

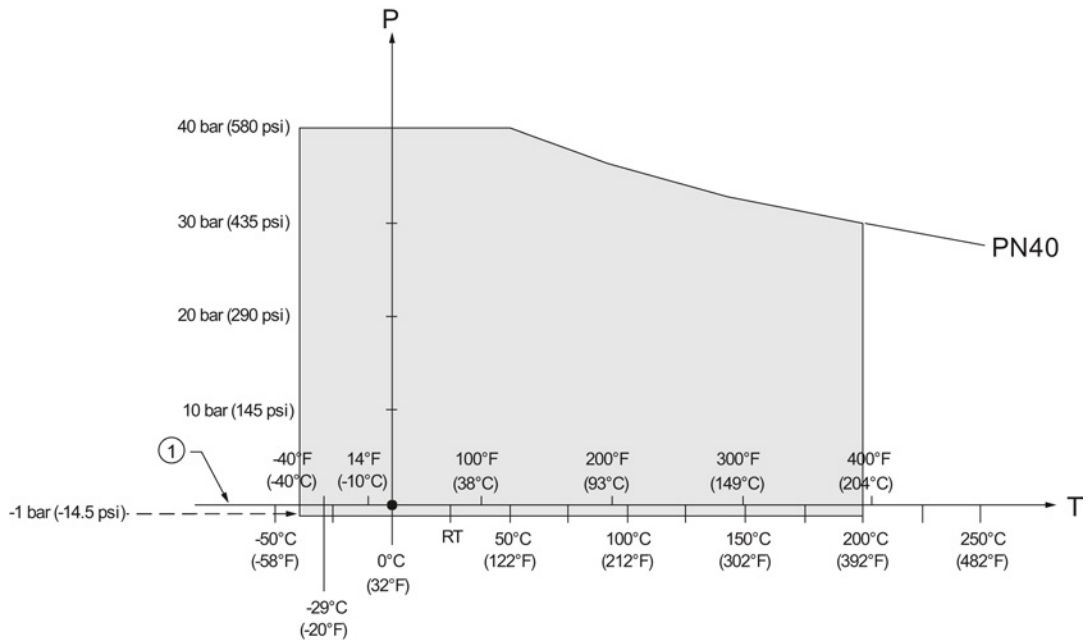

- ① Atmospheric
- P Allowable operating pressures
- T Allowable operating temperatures

ASME B16.5, Class 150: 2", 3", and 4" NPS

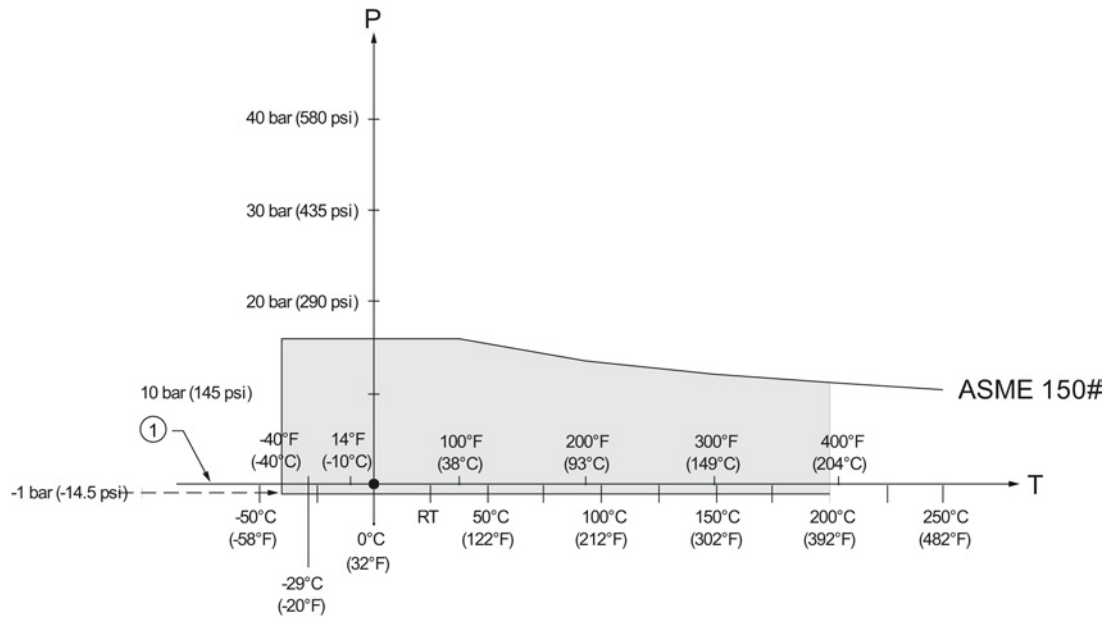

- ① Atmospheric
- P Allowable operating pressures
- T Allowable operating temperatures

ASME B16.5, Class 300: 2", 3", and 4" NPS

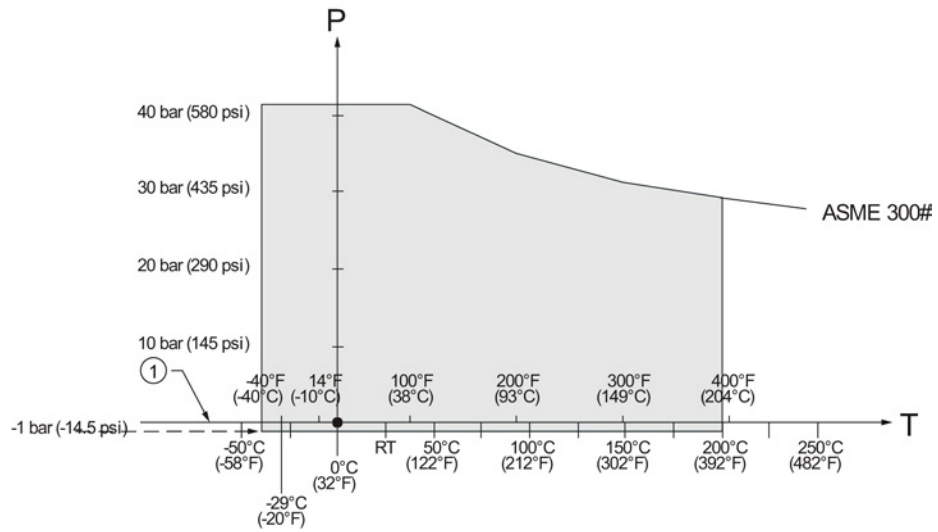

- ① Atmospheric
- P Allowable operating pressures
- T Allowable operating temperatures

A.4.3 Flanged encapsulated antenna

ASME B16.5, Class 150: 2", 3", 4", and 6" NPS

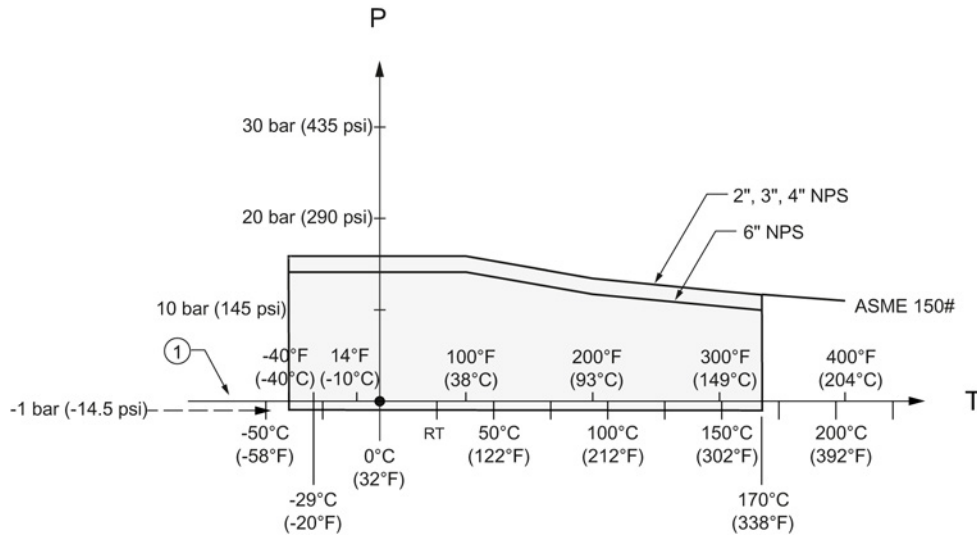

- ① Atmospheric
- P Allowable operating pressures
- T Allowable operating temperatures

JIS B 2220, 10K: 50A, 80A, 100A, and 150A

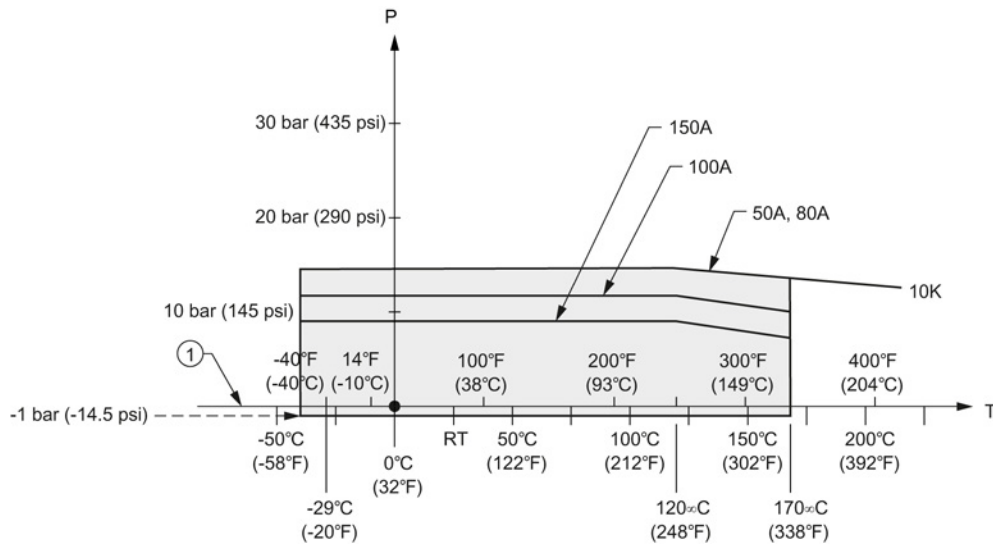

- ① Atmospheric
- P Allowable operating pressures
- T Allowable operating temperatures

EN1092-1, PN10/16: DN50, DN80, DN100, and DN150

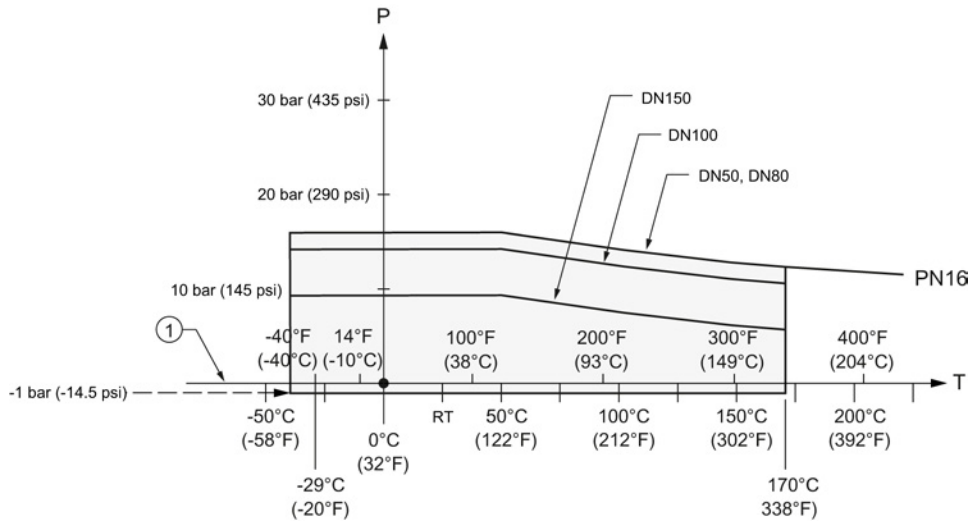

- ① Atmospheric
- P Allowable operating pressures
- T Allowable operating temperatures

A.4.4 PVDF antenna

ASME B1.20.1 2" NPT, EN ISO 228-1 2" G (BSPP), EN 10226-1 2" R (BSPT)

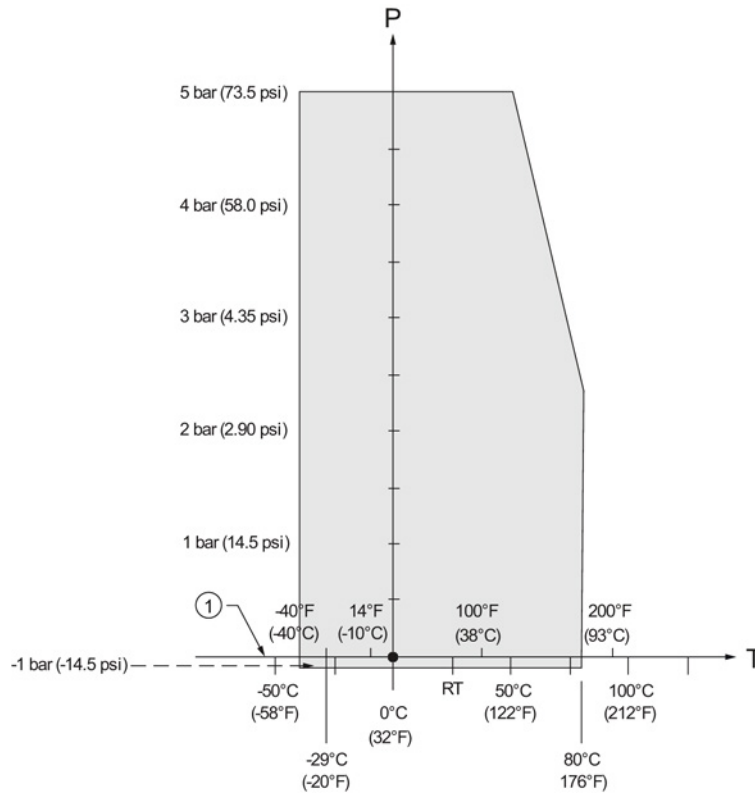

- ① Atmospheric
- P Allowable operating pressures
- T Allowable operating temperatures

A.4.5 Hygienic encapsulated antenna

DIN 11851 Sanitary/Hygienic nozzle/slotted nut: DN50, DN80, and DN100

DIN 11864-1 Aseptic/Hygienic nozzle/slotted nut: DN50, DN80, and DN100

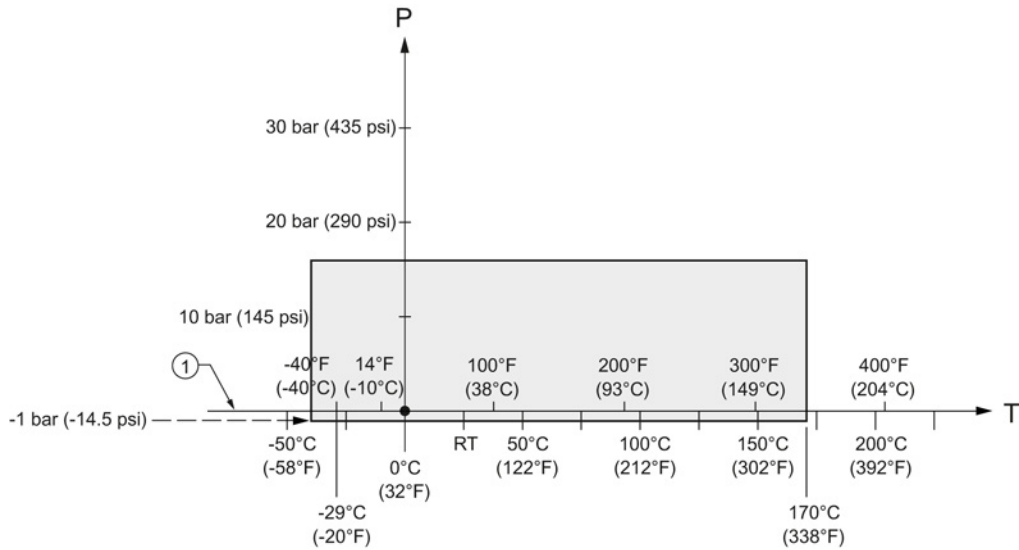

- ① Atmospheric
- P Allowable operating pressures
- T Allowable operating temperatures

DIN 11864-2 Aseptic/Hygienic flanged: DN50, DN80, and DN100

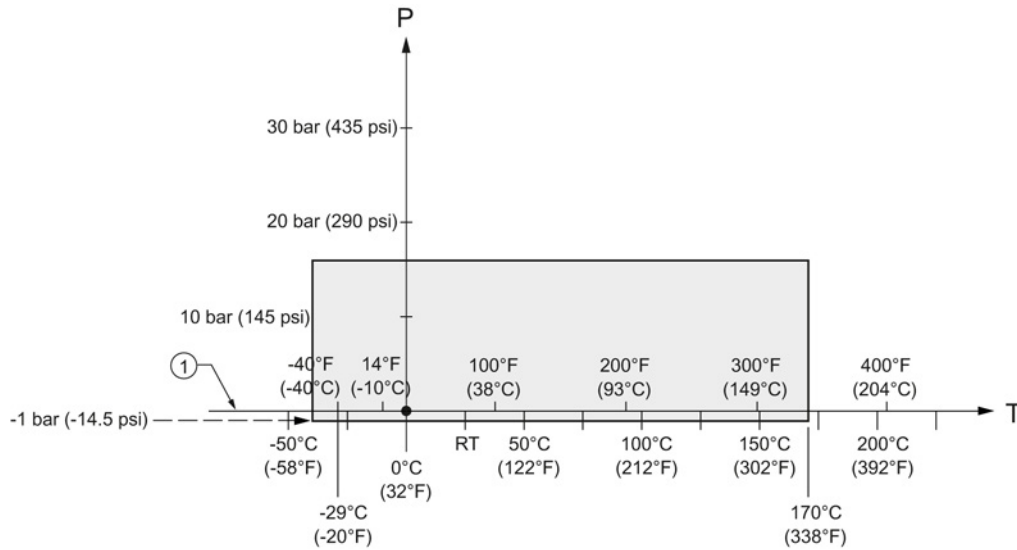

- ① Atmospheric
- P Allowable operating pressures
- T Allowable operating temperatures

Note

For pressure applications, all attachment hardware must be suitably rated.

DIN 11864-3 Aseptic/Hygienic clamp: DN50, DN80, and DN100

ISO 2852 Sanitary/Hygienic clamp: 2", 3", and 4"

Tuchenhagen Varivent face seal clamp: Type N (68 mm) and Type F (50 mm)

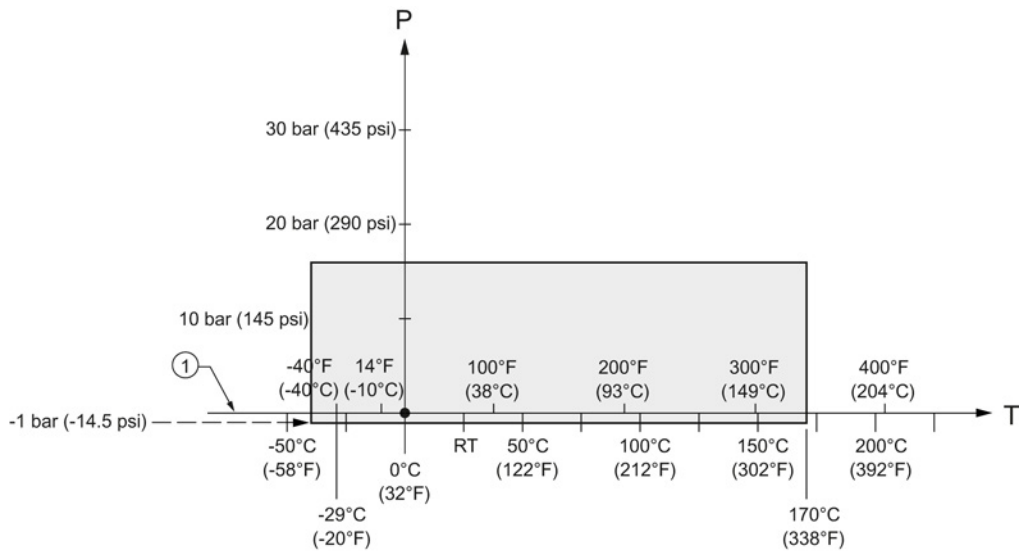

- ① Atmospheric
- P Allowable operating pressures
- T Allowable operating temperatures

Note

For pressure applications, all clamps must be rated accordingly.

B

Appendix B: PROFIBUS PA profile structure

B.1 PROFIBUS Level Device Design

The device follows the profile block model and is implemented as a Profile 3.0, Class B, PA device. Standard profile parameters are used to program the level transducer block.

B.2 Block Model

The Block Model represents how measured values are recorded and processed. All data is viewed from the perspective of the DCS or PLC, so information from the sensor is an input.

The functions of the device are divided into blocks with different areas of responsibility. The blocks are configured by parameters.

The device is implemented with one Physical Block, one Transducer Block (TB), and two Analog Input Function Blocks (AIFB1 and AIFB2).

Physical Block

The Physical Block handles functionality and descriptions relating to the device as a whole: for example, LCD Contrast (functionality) and Firmware Revision and Tag (descriptions).

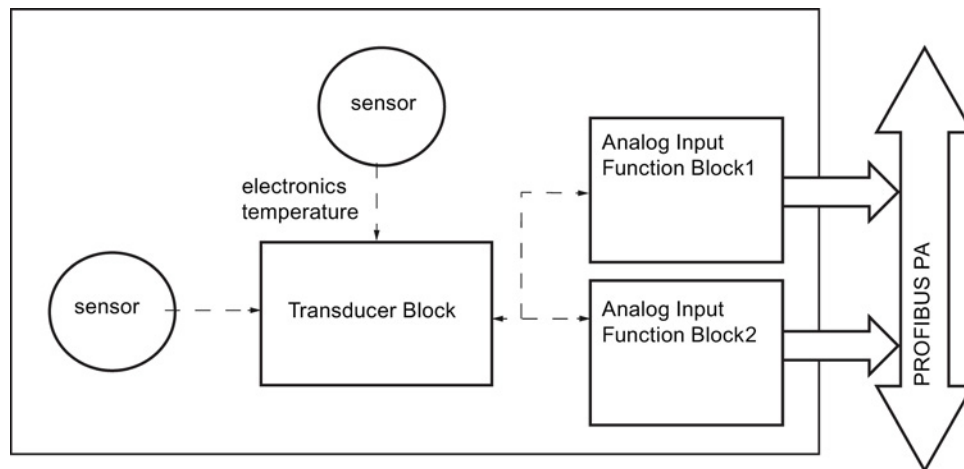

Transducer Block (TB)

The Transducer Block carries out adjustments to the sensor, such as level calibration and volume calibration. It supplies the measurement value [Primary Value (PV), Secondary Value 1 (SV1), or Secondary Value 2 (SV2)] utilized by either or both of the AIFBs.

Analog Input Function Blocks AIFB1 and AIFB2

The two AIFBs are completely independent of each other. They utilize the measurement value output from the Transducer Block [Primary Value (PV), Secondary Value 1 (SV1), or Secondary Value 2 (SV2)] and apply any required quality checks, scaling, and Fail-safe operation selections. The Analog Input Function Block output supplies the measured value and associated status information to the PROFIBUS PA network via cyclic data transfer.

B.2.1 Description of the blocks

B.2.1.1 Transducer Block function groups

The figure below shows the signal flow of measured values from the sensor through the Transducer Block into the output value:

- Primary Value (PV): Level or Volume
- Secondary Value 1 (SV1): Level
- Secondary Value 2 (SV2): Distance

The Transducer Block implements all of the basic parameters (see diagram below), including level to volume calculation, if that option has been selected.

Transducer Block

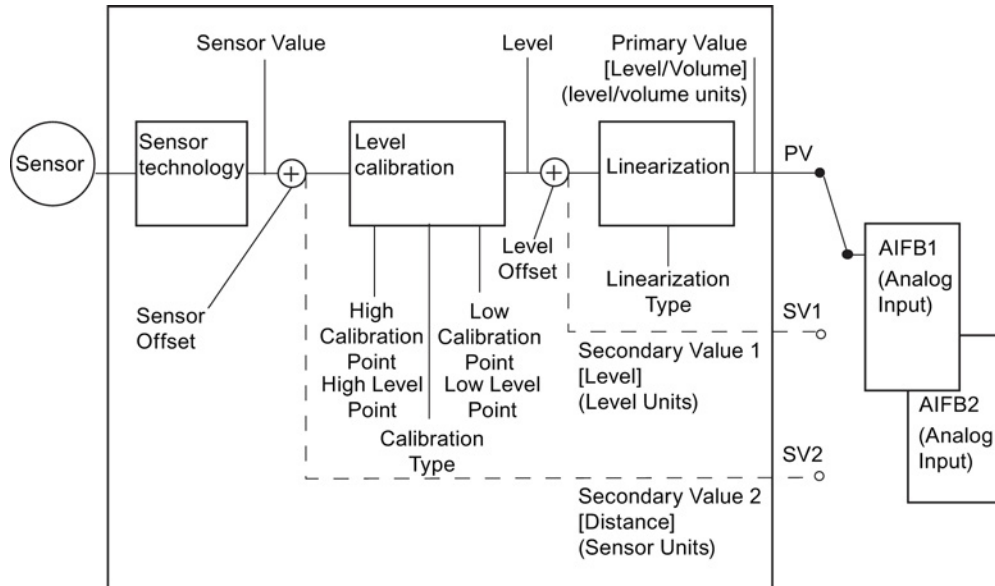

B.2.1.2 How the transducer block works:

1. The sensor technology block selects the proper echo. For an explanation of sensor technology, see Appendix A: Technical Reference (Page 241).
The sensor value (in sensor units) is checked to see if it is within its measuring limits. If the limit is exceeded, this results in a **Bad** status and the error message **Failure in measurement**.
The sensor value is stored in Sensor Value.
The analog signal from the sensor is transformed into a digital representation.
A Sensor Offset (default 0) compensates for changes to the sensor reference point, if necessary.
2. Level Calibration is a linear transfer function that converts a sensor value to a level value.

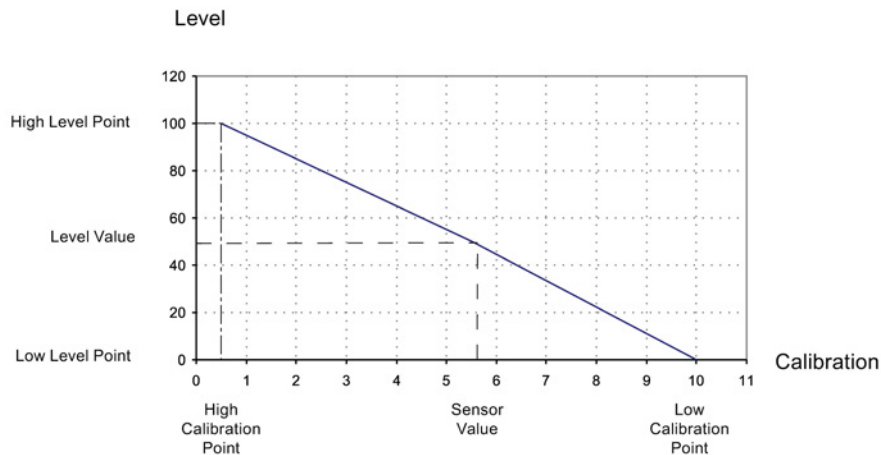

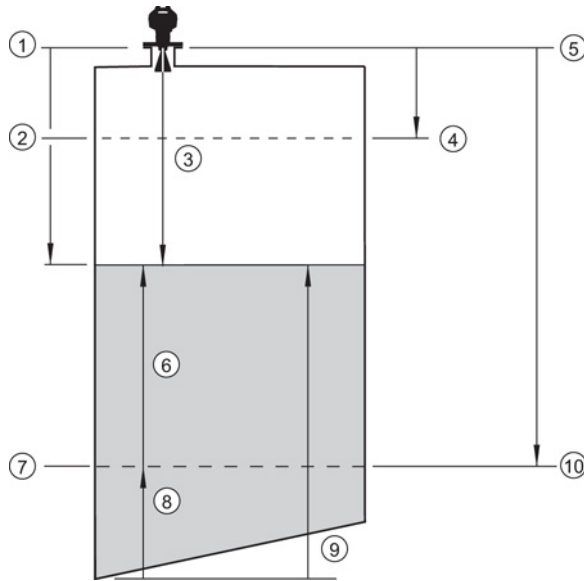

①	Distance/SV2	⑥	Level
②	High level point (default: 100%)	⑦	Low level point (default: 0%)
③	Sensor value ^{a)}	⑧	Level offset ^{c)}
④	High calibration point	⑨	Secondary value 1
⑤	Sensor reference point ^{b)}	⑩	Low calibration point

^{a)} Referenced from Sensor Reference Point.

^{b)} **Sensor Offset (2.3.7.3.)** is a constant offset that can be added to or subtracted from sensor reference point to compensate if the sensor has been changed.

^{c)} Level Offset (default 0) can compensate for specific vessel configurations.

3. Linearization can be carried out to accommodate complex vessel shapes, or to provide level to volume conversion.
4. The Transducer Block provides three possible outputs:
 - Primary Value (PV) / Level or Volume
 - Secondary Value 1 (SV1) / Level
 - Secondary Value 2 (SV2) / Distance (sensor units)

Electronics temperature

The Transducer Block monitors the internal temperature of the device electronics. A change in temperature can provide advance warning of a possible device failure, and allow for preventive maintenance.

If a temperature limit is exceeded, the output value is unchanged but the output status changes. (The permitted limits correspond to those of the permitted ambient temperature.)

Peak indicators allow you to check the maximum and minimum temperatures that have occurred. To see peak temperature values, Open the menu **View – Device Diagnostics**, select **Device Status**, and click on the tab **Device Status**.

B.2.1.3 Analog Input Function Blocks 1 and 2

The input to the AIFB is a value with a status. See Transducer Block function groups (Page 267) for a graphic representation.

Output conversion

The Analog Input Function Blocks can modify the output value.

Scaling

Output Scaling (2.6.6.) allows you to scale the output to any desired units.

Fail-safe

If the status of the input (TB output value or Simulation Value) is **bad**, the fault logic can output either the last usable measured value, or a given substitute value. Set **Fail-safe Mode (2.6.9.)** and, if desired, define a value in **Value (2.6.9.2.)**.

Device/input simulation

You can define a simulated value to be input to the AIFB instead of the output value from the Transducer Block. The simulated value allows the AIFB to be tested independently of the characteristics of the environment.

Actual Mode: Device / Output Simulation

Actual Mode allows you to select one of three possible outputs.

Actual Mode (2.6.2.)	Description	Output value
AUTO	automatic	the automatically-recorded measured value
MAN	manual	a manually-set fixed simulation value
O/S	function block disabled	the preset safety value.

AIFB function groups

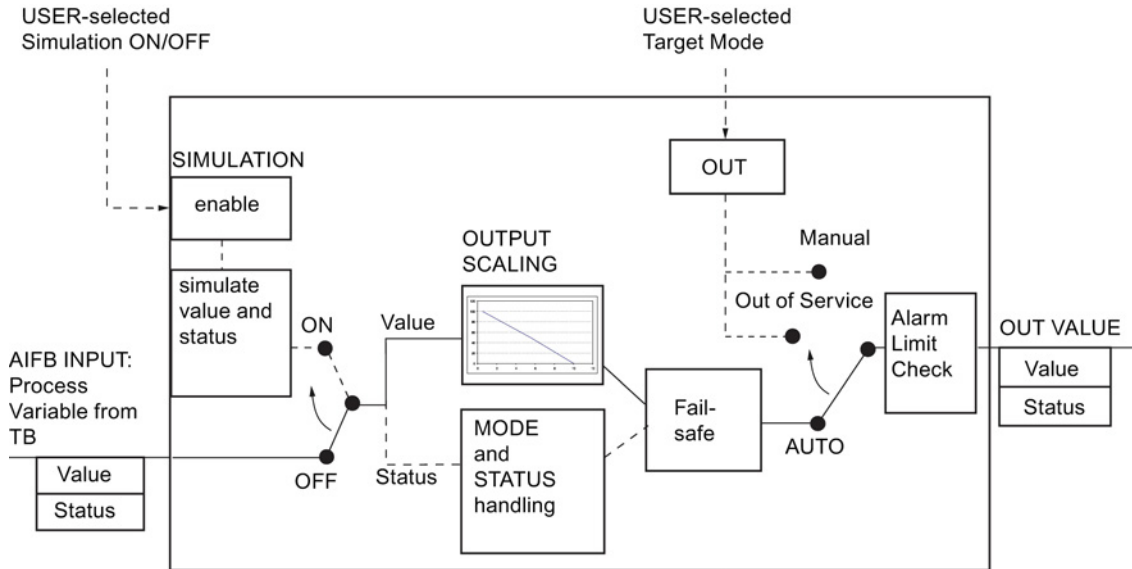

Analog Input Function Block function groups (simulation, mode and status)

Measured values are processed within an Analog Input Function Block to produce the device output. See AIFB function groups (Page 271). The output is communicated via cyclic transfer to PROFIBUS PA and displayed on the LCD.

How an Analog Input Function Block works

The AIFB provides a linear conversion to any desired units.

1. The AIFB Input value is the processed output value of the Transducer Block, in Transducer Block units.
2. The user selects the desired AIFB output units and scaling is applied.

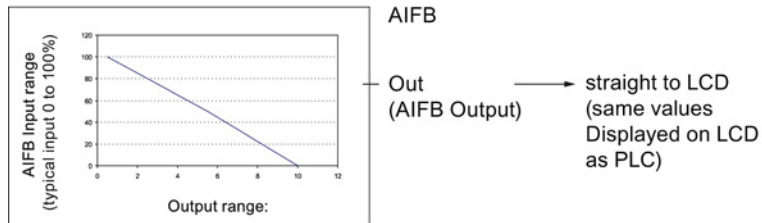

3. Damping may be applied based on a time constant provided by the user. See Damping (Page 249) for details.
4. The status of the input value from the Transducer Block is checked. If the status is Bad, a Fail-safe condition occurs. The output is determined by the setting for Failsafe Mode.
5. **Actual Mode (2.6.2.)** allows the entire AI block to be overridden by a Manual Output value. See **Actual Mode (2.6.2.)** for details.
6. The value is checked against the user-defined warning and alarm limits. The upper and lower limits are defined in units corresponding to the Output range, and a limit hysteresis can be used to adjust the sensitivity. See **Alarms and Warnings (2.6.7.)** for details.
7. The output value (OUT) is communicated via cyclic data transfer.

Appendix C: Communications via PROFIBUS

SITRANS LR250 (PROFIBUS PA) is a Profile Version 3.01, Class B, PA device. It supports Class 1 Master for cyclic and acyclic data exchange, and Class 2 for acyclic services. The full range of SITRANS LR250 functions is available only over a PROFIBUS PA network.

PROFIBUS PA is an open industrial protocol. Full details about PROFIBUS PA can be obtained from PROFIBUS International at:

PROFIBUS PA (<http://www.profibus.com/>)

C.1 Device configuration

To use PROFIBUS PA, you will need a PC configuration tool: we recommend SIMATIC PDM. Please consult the operating instructions or online help for details on using SIMATIC PDM. You can find more information at:

SIMATIC PDM (www.siemens.com/simatic-pdm)

C.1.1 SIMATIC PDM

SIMATIC PDM is a software package used to commission and maintain SITRANS LR250 and other process devices. For more detail see Functions in SIMATIC PDM (Page 75).

C.1.1.1 Electronic Device Description

In order to use **Process Device Manager (PDM)** with PROFIBUS PA, you will need the Electronic Device Description for SITRANS LR250. For details see Electronic Device Description (EDD) (Page 76).

C.2 Network configuration

To configure a PROFIBUS PA Class 1 Master (for example, a PLC), you will need a **GSD** file.

C.2.1 The GSD file

The GSD file **SIEM8150.gsd** is available from the SITRANS LR250 product page on our web site. Go to the product page of our website and click on **Support > Software Downloads:**

Product page (<http://www.siemens.com/LR250>)

C.3 Bus termination

Note

PROFIBUS PA cable shield MUST be terminated at both ends of the cable for it to work properly. Please refer to the PROFIBUS PA User and Installation Guidelines (order number 2.092), available from:

PROFIBUS PA (<http://www.profibus.com/>)

C.4 Power demands

To determine how many devices can be connected to a bus line, calculate the combined maximum current consumption of all the connected devices: 15 mA for SITRANS LR250. Allow a current reserve for safety.

C.5 PROFIBUS address

A unique PROFIBUS address identifies each device on the network. To set the PROFIBUS address see **Device Address (5.1.)**.

Note

- It is possible to change the device address via a Class 1 master (for example, a PLC) and lock the device address to prevent further changes.
 - If this Address Lock is on, the PA address cannot be changed. This lock can be disabled only by performing an Address Reset.
-

Resetting the PROFIBUS address to 126

- Via SIMATIC PDM:
 1. Open the menu **Device – Master Reset** and click on **Reset Address to 126**.
 2. Click on OK: the address will be reset to 126, and if the address lock was on, it will be disabled.
- Via the handheld programmer:

1. Navigate to **Service (4.) > Master Reset (4.1.)**. (You can enter the numeric value instead of navigating via the Arrow keys.)
2. Press **RIGHT Arrow** to open Edit Mode then scroll down to **DEV ADDRESS** and press **RIGHT Arrow** to select it. The address will be reset to 126, and if the address lock was on, it will be disabled.
3. Press **LEFT Arrow** to exit.

C.6 Operating as a profile device

Every manufactured PROFIBUS product has a unique PROFIBUS identification number which identifies it to the system. PROFIBUS Profile Standard version 3.01 also defines a Profile Model which can identify a product as a generic profile device on the network.

SITRANS LR250 can be identified in one of three ways:

	Device Identification	Profile Model
	STD PROFILE	Standard Profile (uses generic GSD for 2 AIFB [ident # = 0x9701])
*	MANUFACTURER	Manufacturer-specific (uses Siemens EDD and GSD file, which identifies the LR250 [PROFIBUS PA]) [ident # = 0x8150]
	STD – AIFB 1 ONLY	Standard Profile AIFB 1 only (uses generic GSD for 1 AIFB) [ident # = 0x9700]

Defining the device as Profile-specific as opposed to Manufacturer-specific makes it possible to exchange the device for any other device of the same profile type without changing the GSD file.

To set up SITRANS LR250 as a profile device see **PROFIBUS Ident Number (5.2.)**.

C.6.1 Configuring a new device

See Configuring a new device (Page 77).

C.6.2 Configuring PROFIBUS PA with an S7-300/ 400 PLC

1. If SITRANS LR250 is not listed in the STEP 7 device catalog, you can download the EDD files from the Siemens Web site and add them to your computer using the device integration procedure specific to your host software (eg. Step 7, or PDM, etc.) version. Go to the product page of our website and click on **Support > Software Downloads:** Product page (<http://www.siemens.com/LR250>)
2. Add the SITRANS LR250 "rack": click and drag the SITRANS LR250 folder from the hardware catalog.
3. Fill the rack with desired modules, by dragging and dropping them from the hardware catalog.
4. After configuring PROFIBUS PA in steps 2 and 3, download it to the PLC.
5. Add code to the PLC program to read data consistently using the SFC14.

C.7 Cyclic versus acyclic data

When you request data from a device via PROFIBUS PA, you have two choices. Cyclic data is provided at every bus scan: acyclic data is requested and provided as needed.

Input information is always requested at every bus scan and is set up as cyclic data. Configuration information is only needed periodically and is set up as acyclic data.

C.7.1 Cyclic data

When you configure SITRANS LR250 on the PROFIBUS PA bus, there are two slots available for modules.

Note

Each of the slots has to have a module defined in it.

Slot 0 always transmits **AIFB1** information; slot 1 defaults to Free Place, but can be changed to **AIFB2** information. If you do not wish to have data transmitted, then you must use a **Free Place** module in that slot.

Each of the two Analog Input Function Blocks can be set up to return **Level, Distance, or Volume**. Within the function blocks, the values are scaled according to the user requirements [see Analog Input Function Blocks 1 and 2 (Page 270) for details].

AIFB1 and **AIFB2** return 5 bytes of data each:

	Floating Point				Status
AIFB1	byte 1	byte 2	byte 3	byte 4	byte 5
AIFB2	byte 6	byte 7	byte 8	byte 9	byte 10

The first 4 bytes are the floating point representation (IEEE) of the variable. The variables are the outputs of the function block. The 5th byte is the status word and the list of possible values is given in the chart below.

The 5 bytes must be read consistently, in a contiguous chunk: they cannot be read byte by byte, and cannot suffer an interrupt. If you are using an S7-300 / 400, you will need to use SFC14 DPRD_DAT: Read Consistent Data of a Standard PD Slave.

C.8 Status byte

In PROFIBUS PA there are two possible types of status byte:

- **status byte:** originally defined in Profile Standard V3.0
- **condensed status:** an alternative status byte defined in Profile Standard V3.01

You can choose which type of status byte will be returned, by enabling or disabling **Condensed Status (3.4.)**: see **Enable (3.4.1.)** for details. When Condensed Status is disabled, Status Byte will be returned, and the following codes will be used.

Status Codes for good quality	
Values in hex notation	Description
0x80	Data is GOOD.
0x84	A parameter in the function block has been changed: status active for 10 s
0x89	Active low warning.
0x8A	Active high warning.
0x8D	Active low alarm.
0x8E	Active high alarm.

Status Codes for Uncertain Quality	
Values in hex notation	Description
0x4B	Value is a substituted value (normally used in Failsafe).
0x4C/0x4F	Initial value.
0x47	Last usable value.

Status Codes for Bad Quality	
Values in hex notation	Description
0x10	The LOE timer has expired: this could be caused by LOE or by a sensor malfunction: value is BAD.
0x01	There is an error in the configuration of the function blocks in PROFIBUS PA ^{a)} .
0X1F	The function block, or the transducer block, has been placed out of service.

- ^{a)} This could happen when a firmware download has been done, but a system reset has not been done. This could also happen if the function blocks are not configured properly using the handheld programmer, PDM or acyclic services.

C.9 Condensed status

These codes are available when Condensed Status is enabled. See **Condensed Status (3.4.)** for more details.

Condensed Status (GOOD)		
Hex value	Status - GOOD	Description
0x80	GOOD – ok	No error or special condition is associated with this value.
0x84	GOOD – update event	Set if the value is good and the block has an active Update event. (This status remains active for 20 seconds.)
0x86	GOOD – active advisory alarm	Set if the value is good and the block has an active Alarm.
0x80 ...0x8E	GOOD – limit check/ update event	See Status Codes for Good Quality (Page 280).
0xA0 ...0xA3	GOOD – initiate fail safe	This fault is not generated by the product, but can be simulated.
0xA4 ...0xA7	GOOD – maintenance required	Value is valid. Maintenance is recommended within a medium-term period.
0xA8 ...0xAB	GOOD – maintenance demanded	Value is valid. Maintenance is demanded within a short- term period.
0xBC ...0xBF	GOOD – function check	Device performs internal function check without influencing the process. Value is valid.

Condensed Status (UNCERTAIN)		
Hex value	Status - UNCERTAIN	Description
0x45	UNCERTAIN – substitute set	Output of Failsafe logic only.
0x4F	UNCERTAIN – initial value	Default value as long as no measured value is available or until a diagnosis is made that affects the value and the status accorded to it.
0x68 ...0x6B	UNCERTAIN – maintenance demanded	Usability of the process value depends on the application. Value is potentially invalid. Cause can be determined by reading the extended diagnostics ^{a)} . Maintenance is demanded within a short-term period.
0x73	UNCERTAIN – simulated value, start	<p>Indicates the start of a simulation.</p> <p>Simulation of a measured value or Input FB mode changes from AUTO to MAN.</p> <ul style="list-style-type: none"> • This status remains active for at least 10 seconds: <ul style="list-style-type: none"> – after enabling simulation – after setting the FB to MAN mode – after a restart (e.g. power down cycle) if the simulation is enabled or the FB is in MAN mode – after passivation is cleared if simulation is enabled or the FB is in MAN mode • In MAN mode the status remains until a subsequent write command overwrites the OUT value after the 10 seconds have expired. • In simulation mode the written status is buffered and appears in the value flow after 10 seconds. However the new written SIMULATE parameter with its status can be read before the 10 seconds have expired.
0x74 ...0x77	UNCERTAIN – simulated value, end	<p>Indicates the end of a simulation.</p> <p>Simulation of a measured value is disabled or Input FB mode changes from MAN to AUTO.</p> <p>This Status remains active for 10 seconds after simulation ends.</p> <p>While this status is active there is no reliable process value. Measured values and their status are updated afterwards.</p>

See Acyclic Extended Diagnostics (General Fault Codes) (Page 286).

Condensed Status (BAD)		
Hex value	Status - BAD	Description
0x00	BAD – non specific	Proxy determines that a device does not communicate.
0x23	BAD – passivated (diagnostics alerts disabled)	Configured failsafe value is used, accompanied by this status.
0x24 ...0x27	BAD – maintenance alarm, more diagnosis available	No measurement available because of a failure.
0x25	BAD – process related, no maintenance	No measurement available because of invalid process conditions.
0x3C ...0x3F	BAD – function check / local override, value not usable	Occurs during cleaning or calibration process.

C.10 Diagnostics

All diagnostic information shown below is viewable via PDM.

C.10.1 Diagnosis reply (available cyclically)

During DPV0 data exchange, the PROFIBUS PA slave will notify the Master when a serious error occurs. The Master will then send a Diagnosis request. The reply to this request is normally logged in the PLC and is referred to as the "Hex values."

The reply may contain two parts. The first part is 6 bytes long and is defined by the PROFIBUS standard. If there is a second part, it is called the 'extended cyclic diagnosis' and it is 8 bytes long. The last 4 bytes of the extended diagnostic message give the error diagnosis [see Extended Mode Diagnosis (Page 284) and Condensed Mode Diagnosis (Page 285)].

The same information is also available acyclically via the Diagnosis Object.

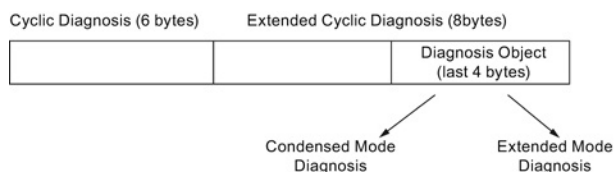

C.10.2 Diagnosis object (available cyclically or acyclically)

This consists of four bytes.

In PROFIBUS PA there are two options for the Diagnosis Object:

- Extended Mode Diagnosis (Page 284)
- Condensed Mode Diagnosis (Page 285)

You can choose which of these will be returned, by enabling or disabling Condensed Status. See **Enable (3.4.1.)**. When Condensed Status is disabled **Extended Mode Diagnosis** will be returned, and the following codes will be used.

C.10.3 Extended mode diagnosis

Extended Mode Diagnosis				
Hex values	Byte	Bit	Description	Indication class ^{a)}
0x01000000	0	0	Electronics failure	R
0x02000000		1	Mechanical failure	R
0x04000000		2	Motor Temperature too high	R
0x08000000		3	Electronics temperature too high	R
0x10000000		4	Memory error	R
0x20000000		5	Measurement failure	R
0x40000000		6	Device not initialized (no calibration)	R
0x80000000		7	Self calibration failed	R
0x00010000	1	0	Zero point error (limit position)	R
0x00020000		1	Power supply failure (electrical, pneumatic)	R
0x00040000		2	Configuration invalid	R
0x00080000		3	New startup carried out (Warm Start)	A
0x00100000		4	Restart carried out (Cold Start)	A
0x00200000		5	Maintenance required	R
0x00400000		6	Characterization invalid	R
0x00800000		7	Set to 1 (one), if the Ident_Number of the running cyclic data transfer and the value of Physical Block IDENT__NUMBER_SELECTOR parameter are different.	R
	2	0 to 7	Reserved for use within the PNO	
	3	0 to 6	Reserved for use within the PNO	
0x00000080		7	More diagnosis information is available	

^{a)} **R** indicates the message remains active as long as the reason for the message exists.

A indicates the message will automatically reset after 10 seconds.

Values of the DIAGNOSIS bit: **0** = not set; **1** = set

C.10.4 Condensed mode diagnosis

Condensed Mode Diagnosis				
Hex values	Byte	Bit	Description	Indication class ^{a)}
0x01000000	0	0	Electronics failure	R
0x02000000		1	Mechanical failure	R
0x04000000		2	Motor Temperature too high	R
0x08000000		3	Electronics temperature too high	R
0x10000000		4	Memory error	R
0x20000000		5	Measurement failure	R
0x40000000		6	Device not initialized (no calibration)	R
0x80000000		7	Self calibration failed	R
0x00080000	2	3	New startup carried out (Warm Start)	R
0x00100000		4	Restart carried out (Cold Start)	R
0x00200000		5	Maintenance required	R
0x00400000		6	Reserved for use within the PNO	A
0x00800000		7	Set to 1 (one), if the Ident_Number of the running cyclic data transfer and the value of Physical Block IDENT_NUMBER_SELECTOR parameter are different.	A
0x00010000	3	0	Failure of the device or armature	R
0x00020000		1	Maintenance demanded	R
0x00040000		2	Device is in function check mode, or simulation, or under local control e.g. maintenance	R
0x00080000		3	The process conditions do not allow the return of valid values. (Set if a value has the quality Uncertain - Process related, no maintenance or Bad - Process related, no maintenance.)	R
		4 to 7	Reserved for use within the PNO	
	4	0 to 6	Reserved for use within the PNO	
0x80000000		7	0: There is no more information available 1: More diagnosis information is available in DIAGNOSIS_EXTENSION	

^{a)} **R** indicates the message remains active as long as the reason for the message exists. **A** indicates the message will automatically reset after 10 seconds.

C.10.5 Acyclic extended diagnostics (general fault codes)

In addition to the extended diagnostics available by cyclic data exchange (shown above), further extended diagnostics are available via acyclic communications. This consists of six bytes. See Diagnosis reply (available cyclically) (Page 283) for information on the location of the **Extended Diagnostics**.

Note

Certain fault codes (identified by an asterisk [*] in the table below) will persist until a manual reset has been performed [see **Fault Reset (3.2.)**].

Acyclic Extended Diagnostics /General Fault Codes				
LCD display	Meaning	Corrective Action	Byte	Bit
S:0	The device was unable to get a measurement within the Failsafe LOE Timer period. Possible causes: faulty installation, antenna material buildup, foaming/other adverse process conditions, invalid calibration range.	<ul style="list-style-type: none"> • Ensure installation details are correct. • Ensure no antenna material buildup. Clean if necessary. • Adjust process conditions to minimize foam or other adverse conditions. • Correct range calibration. • If fault persists, contact your local Siemens representative. 	0	0
S:2	Unable to collect profile because of a power condition that is outside the operating range of the device.	Repair required. Contact your local Siemens representative.		2
S:3	Device is nearing its lifetime limit according to the value set in Maintenance Required Limit.	Replacement is recommended.		3
S:4	Device is nearing its lifetime limit according to the value set in Maintenance Demanded Limit.	Replacement is recommended.		4
S:6	Sensor is nearing its lifetime limit according to the value set in Maintenance Required Limit.	Replacement is recommended.		6
S:7	Sensor is nearing its lifetime limit according to the value set in Maintenance Demanded Limit.	Replacement is recommended.		7
S:8	Service interval as defined in Maintenance Required Limit has expired.	Perform service		
S:9	Service interval as defined in Maintenance Demanded Limit has expired.	Perform service.	1	
S:10	Input parameters High Calibration Point and Low Calibration Point are the same.	<ul style="list-style-type: none"> • Check calibration settings of device. • Ensure settings for High Calibration Point and Low Calibration Point are different. 	3	
S:11	Internal temperature sensor failure.	Repair required. Contact your local Siemens representative.	4	

Acyclic Extended Diagnostics /General Fault Codes					
LCD display		Meaning	Corrective Action	Byte	Bit
S:12	*	Internal temperature of the device has exceeded specifications: it is operating outside its temperature range.	<ul style="list-style-type: none"> Relocate device and/or lower process temperature enough to cool device. Inspect for heat-related damage and contact your local Siemens representative if repair is required. Fault code will persist until a manual reset is performed using PDM or the LCD interface. 	1	5
S:14		Upper and lower input values (Process Value Scale) for AIFB1 are the same.	<ul style="list-style-type: none"> Check configuration for AIFB1. Ensure that Upper Value and Lower Value (Process Value Scale) are not the same. 		6
S:15		Upper and lower input values (Process Value Scale) for AIFB2 are the same.	<ul style="list-style-type: none"> Check configuration for AIFB2. Ensure that Upper Value and Lower Value (Process Value Scale) are not the same. 		7
S:17		Calibration interval as defined in Maintenance Required Limit has expired.	Perform calibration.	2	1
S:18		Calibration interval as defined in Maintenance Demanded Limit has expired.	Perform calibration.		2
S:28		Internal device failure caused by a RAM memory error.	Repair required: contact your local Siemens representative.	3	4
S:29		EEPROM damaged.	Repair required: contact your local Siemens representative.		5
S:31		Flash error.	Repair required: contact your local Siemens representative.		7

Acyclic Extended Diagnostics /General Fault Codes				
LCD display	Meaning	Corrective Action	Byte	Bit
S:32	IDENT number conflict.	Ensure value of the Ident number selector is correct for the network configuration. If it is correct, the device needs to be re-parameterized by the PLC.	4	0
S:33	Factory calibration for the internal temperature sensor has been lost.	Repair required: contact your local Siemens representative.		1
S:34	Factory calibration for the device has been lost.	Repair required: contact your local Siemens representative.		2
S:35	Factory calibration for the device has been lost.	Repair required: contact your local Siemens representative.		3
S:36	Unable to start microwave module.	Cycle power. If fault persists, contact your local Siemens representative.		4
S:37	Measurement hardware problem.	Cycle power. If fault persists, contact your local Siemens representative.		5
S:38	Microwave module hardware failure: unable to calculate distance measurement.	Cycle power. If fault persists, contact your local Siemens representative.		6
S:43	Factory calibration for the radar receiver has been lost.	Repair required: contact your local Siemens representative.	5	3

C.10.6 Acyclic data

SITRANS LR250 supports up to four simultaneous connections by a Class 2 Master (C2 connection). It supports one connection by a Class 1 Master (C1 connection).

In order for a Class 1 Master to read parameters from a device, it needs to know the slot and absolute index of the parameter.

The parameters are all listed in SIMATIC PDM under Help. If you do not have SIMATIC PDM you can download the EDD (Electronic Device Description) and reference the HTML help file directly.

To find the slot and index numbers via SIMATIC PDM, go to Help > Communications, and select the appropriate block from the list. For each parameter, the slot and the relative index is listed. For example.

AIFB 1		
Index	Parameter	Datatype
1	Static Revision No.	UNSIGNED_INTEGER (2)

Each block has a slot number and an Index Offset value.

Block Name	Slot	Index Offset
Physical block	0	16
Transducer block	0	77
AIFB 1	1	16
AIFB 2	2	16

To get the absolute index for any parameter, add the Index Offset for the appropriate block to the relative index for that parameter. The parameter takes the slot number of the block in which it is located.

For example:

- Parameter **Static Revision Number** has relative index = 1 and is located on AIFB1.
- It has Absolute Index = 17 (relative index 1 + index offset 16).
- It is located at Slot 1 (the slot number for AIFB 1).

D

Appendix D: Certificates and Support

D.1 Certificates

Certificates can be downloaded from our website at:

Product page (<http://www.siemens.com/LR250>).

D.2 Technical support

If you have any technical questions about the device described in these Operating Instructions and do not find the right answers, you can contact Customer Support:

- Via the Internet using the **Support Request:**
Support request (<http://www.siemens.com/automation/support-request>)
- Via Phone:
 - Europe: +49 (0)911 895 7222
 - America: +1 423 262 5710
 - Asia-Pacific: +86 10 6475 7575

Further information about our technical support is available on the Internet at
Technical support (<http://support.automation.siemens.com/WW/view/en/16604318>)

Service & Support on the Internet

In addition to our documentation, we offer a comprehensive knowledge base online on the Internet at:

Service & Support (<http://www.siemens.com/automation/service&support>)

There you will find:

- The latest product information, FAQs, downloads, tips and tricks.
- Our newsletter, providing you with the latest information about your products.
- Our bulletin board, where users and specialists share their knowledge worldwide.
- You can find your local contact partner for Industry Automation and Drives Technologies in our partner database.
- Information about field service, repairs, spare parts and lots more under "Services."

Additional Support

Please contact your local Siemens representative and offices if you have additional questions about the device

Find your contact partner at:

Local contact person (<http://www.siemens.com/automation/partner>)

List of abbreviations

Short form	Long form	Description	Units
3-A	3-A Sanitary Standards, Inc.		
AIFB	Analog Input Function Block		
CE / FM / CSA	Conformité Européene / Factory Mutual / Canadian Standards Association	safety approval	
C _i	Internal capacitance		F
D/A	Dialog to analog		
DCS	Distributed Control System	control room apparatus	
dK	dielectric constant		
EDD	Electronic Device Description		
EHEDG	European Hygienic Engineering Design Group		
FEA	Flanged Encapsulated Antenna		
FDA	Food and Drug Administration		
HEA	Hygienic Encapsulated Antenna		
I _i	Input current		mA
I _o	Output current		mA
IS	Intrinsically Safe	safety approval	
L _i	Internal inductance		mH
mH	milliHenry	10 ⁻³	H
μF	microFarad	10 ⁻⁶	F
μs	microsecond	10 ⁻⁶	s
PED	Pressure Equipment Directive	safety approval	
pF	pico Farads	10 ⁻¹²	F
ppm	parts per million		
PV	Primary Variable	measured value	
PVDF	Polyvinylidene fluoride		
SELV	Safety extra low voltage		
SV	Secondary Variable	equivalent value	
TB	Transducer Block		
TFM1600 PTFE	Modified PTFE	polytetrafluoroethylene with perfluoropropyl vinyl ether (PPVE) modifier	
TVT	Time Varying Threshold	sensitivity threshold	
U _i	Input voltage		V
U _o	Output voltage		V

LCD menu structure

14

Note

- In Navigation mode, **ARROW keys** (   ) navigate the menu in the direction of the arrow. See Parameter Reference (Page 107) for detailed information and instructions.
-

LEVEL METER

- 1. QUICK START**
 - 1.1 LANGUAGE
 - 1.2 MATERIAL
 - 1.3 RESPONSE RATE
 - 1.4 UNITS
 - 1.5 OPERAT. MODE
 - 1.6 LOW CALIB. PT.
 - 1.7 HIGH CALIB. PT.
 - 1.8 APPLY?
- 1. SETUP**
 - 2.1 IDENTIFICATION
 - 2.1.1 TAG
 - 2.1.2 DESCRIPTOR
 - 2.1.3 MESSAGE
 - 2.2 DEVICE
 - 2.2.1 HARDWARE REV
 - 2.2.2 FIRMWARE REV
 - 2.2.3 LOADER REV
 - 2.2.4 ORDER OPTION
 - 2.3 SENSOR
 - 2.3.1 UNIT
 - 2.3.2 LEVEL UNIT
 - 2.3.3 PV UNITS
 - 2.3.4 TEMP UNITS
 - 2.3.5 MATERIAL
 - 2.3.6 LOE TIMER
 - 2.3.7 CALIBRATION
 - 2.3.7.1 LOW CALIB. PT.
 - 2.3.7.2 HIGH CALIB. PT.
 - 2.3.7.3 SENSOR OFFSET
 - 2.3.7.4 LOW LEVEL POINT
 - 2.3.7.5 HIGH LEVEL POINT
 - 2.3.7.6 LEVEL OFFSET
 - 2.3.8 RATE
 - 2.3.8.1 RESPONSE RATE
 - 2.3.8.2 FILL RATE/MIN
 - 2.3.8.3 EMPTY RATE/MIN
 - 2.4 LINEARIZATION
 - 2.4.1 VOLUME
 - 2.4.1.1 VESSEL SHAPE
 - 2.4.1.2 MAX. VOLUME
 - 2.4.1.3 DIMENS. A
 - 2.4.1.4 DIMENS. L
 - 2.4.1.5 XY INDEX
 - 2.4.1.6 X VALUE
 - 2.4.1.7 Y VALUE

2. SETUP (cont'd)

2.5 SIGNAL PROC.

- 2.5.1 NEAR RANGE
- 2.5.2 FAR RANGE
- 2.5.3 PROPAG. FACTOR
- 2.5.4 MIN. SENSOR VAL.
- 2.5.5 MAX. SENSOR VAL.
- 2.5.6 SHOTS
- 2.5.7 ECHO SELECT
 - 2.5.7.1 ALGORITHM
 - 2.5.7.2 POS. DETECT
 - 2.5.7.3 ECHO THRESHOLD
 - 2.5.7.4 CLEF RANGE
- 2.5.8 SAMPLING
 - 2.5.8.1 ECHO LOCK
 - 2.5.8.2 UP SAMP.
 - 2.5.8.3 DOWN SAMP.
- 2.5.9 ECHO QUALITY
 - 2.5.9.1 CONFIDENCE
 - 2.5.9.2 ECHO STRENGTH
- 2.5.10 TVT SETUP
 - 2.5.10.1 AUTO ECHO SUPP..
 - 2.5.10.2 AUTO SUPP. RANGE
 - 2.5.10.3 HOVER LEVEL
 - 2.5.10.4 SHAPER MODE
- 2.5.11 TVT SHAPER
 - 2.5.11.1 BRKPT. 1-9
 - 2.5.11.2 BRKPT. 10-18
 - 2.5.11.3 BRKPT. 19-27
 - 2.5.11.4 BRKPT. 28-36
 - 2.5.11.5 BRKPT. 37-40

2.6 AIFB 1

- 2.6.1 STATIC REV. NO.
- 2.6.2 MODE
- 2.6.3 CHANNEL
- 2.6.4 LABEL
- 2.6.5 INPUT SCALING
 - 2.6.5.1 UPPER VALUE
 - 2.6.5.2 LOWER VALUE
- 2.6.6 OUTPUT SCALING
 - 2.6.6.1 UPPER VALUE
 - 2.6.6.2 LOWER VALUE
- 2.6.7 ALARMS & WARN...
 - 2.6.7.1 HI LIMIT ALARM
 - 2.6.7.2 HI LIMIT WARN
 - 2.6.7.3 LO LIMIT WARN
 - 2.6.7.4 LO LIMIT ALARM
 - 2.6.7.5 LIMIT HYSTERESI..
- 2.6.8 DISPLAY
 - 2.6.8.1 FILTER TIME CONS..
 - 2.6.8.2 UNIT
 - 2.6.8.3 OUT UNIT TEXT
 - 2.6.8.4 DECIMAL POINT
- 2.6.9 FAIL-SAFE MODE
 - 2.6.9.1 MODE
 - 2.6.9.2 VALUE

- 2. SETUP (cont'd)
 - 2.7 AIFB 2
 - 2.7.1 STATIC REV. NO.
 - 2.7.2 MODE
 - 2.7.3 CHANNEL
 - 2.7.4 LABEL
 - 2.7.5 INPUT SCALING
 - 2.7.5.1 UPPER VALUE
 - 2.7.5.2 LOWER VALUE
 - 2.7.6 OUTPUT SCALING
 - 2.7.6.1 UPPER VALUE
 - 2.7.6.2 LOWER VALUE
 - 2.7.7 ALARMS & WARN...
 - 2.7.7.1 HI LIMIT ALARM
 - 2.7.7.2 HI LIMIT WARN
 - 2.7.7.3 LO LIMIT WARN
 - 2.7.7.4 LO LIMIT ALARM
 - 2.7.7.5 LIMIT HYSTERESIS
 - 2.7.8 DISPLAY
 - 2.7.8.1 FILTER TIME CONST..
 - 2.7.8.2 UNIT
 - 2.7.8.3 OUT UNIT TEXT
 - 2.7.8.4 DECIMAL POINT
 - 2.7.9 FAIL-SAFE MODE
 - 2.7.9.1 MODE
 - 2.7.9.2 VALUE
 - 2.8 MEAS. VALUES
 - 2.8.1 MAIN OUTPUT
 - 2.8.2 O/P NO LINEAR.
 - 2.8.3 O/P NO OFFSETS
- 3. DIAGNOSTICS
 - 3.1 ECHO PROFILE
 - 3.2 FAULT RESET
 - 3.3 ELECT. TEMP.
 - 3.3.1 MIN. VALUE
 - 3.3.2 MAX. VALUE
 - 3.4 COND. STAT.
 - 3.4.1 ENABLE
 - 3.4.2 FEAT. SUPPORTED
 - 3.4.3 FEAT. ENABLED
 - 3.5 ALLOCATION
 - 3.5.1 EVENT INDEX
 - 3.5.2 EVENT STAT.
 - 3.5.3 EVENT DIAG.
 - 3.6 PEAK VALUES
 - 3.6.1 MIN. MEAS. VALUE
 - 3.6.2 MAX. MEAS. VALUE
 - 3.6.3 MIN. OUTPUT FB1
 - 3.6.4 MAX. OUTPUT FB1
 - 3.6.5 MIN. OUTPUT FB2
 - 3.6.6 MAX. OUTPUT FB2
- 4. SERVICE
 - 4.1 MASTER RESET
 - 4.2 REMAIN. DEV. LIFE
 - 4.2.1 LIFETIME EXPECT..
 - 4.2.2 TIME IN OPER.
 - 4.2.3 REMAIN. LIFETIM..
 - 4.2.4 REMINDER ACTIV.

- 4. SERVICE (cont'd)
 - 4.2.5 REMIND. 1 (REQ)
 - 4.2.6 REMIND. 2 (DEM)
 - 4.2.7 MAINT STAT
 - 4.2.8 ACK STATUS
 - 4.2.9 ACK
 - 4.3 REMAIN. SENS. LIFE
 - 4.3.1 LIFETIME EXPECT..
 - 4.3.2 TIME IN OPER..
 - 4.3.3 REMAIN. LIFETIM..
 - 4.3.4 REMINDER ACTIV..
 - 4.3.5 REMIND. 1 (REQ)
 - 4.3.6 REMIND. 2 (DEM)
 - 4.3.7 MAINT STAT
 - 4.3.8 ACK STATUS
 - 4.3.9 ACK
 - 4.4 SERVICE SCHED.
 - 4.4.1 SERV. INTERVAL
 - 4.4.2 TIME LAST SERV.
 - 4.4.3 TIME NEXT SERV.
 - 4.4.4 REMINDER ACTIV..
 - 4.4.5 REMIND. 1 (REQ)
 - 4.4.6 REMIND. 2 (DEM)
 - 4.4.7 MAINT STAT
 - 4.4.8 ACK STATUS
 - 4.4.9 ACK
 - 4.5 CALIB SCHED.
 - 4.5.1 CALIB. INTERNAL
 - 4.5.2 TIME LAST CALIB.
 - 4.5.3 TIME NEXT CALIB.
 - 4.5.4 REMINDER ACTIV..
 - 4.5.5 REMIND. 1 (REQ)
 - 4.5.6 REMIND. 2 (DEM)
 - 4.5.7 MAINT STAT
 - 4.5.8 ACK STATUS
 - 4.5.9 ACK
 - 4.6 MANUF. DATE
 - 4.7 POWERED HOURS
 - 4.8 POWERON RESETS
 - 4.9 LCD FAST MODE
 - 4.10 LCD CONTRAST
- 5. COMMUNICATION
 - 5.1 DEVICE ADDRESS
 - 5.2 PROFIBUS IDENT
- 6. SECURITY
 - 6.1 REMOTE ACCESS
 - 6.1.1 REMOTE LOCKOUT
 - 6.2 LOCAL ACCESS
 - 6.2.1 WRITE PROTECTION
 - 6.2.2 LOCAL OPERATION
- 7. LANGUAGE

Glossary

accuracy

degree of conformity of a measure to a standard or a true value.

agitator

mechanical apparatus for mixing or aerating. A device for creating turbulence.

algorithm

a prescribed set of well-defined rules or processes for the solution of a problem in a finite number of steps.

ambient temperature

the temperature of the surrounding air that comes in contact with the enclosure of the device.

antenna

an aerial which sends out and receives a signal in a specific direction. There are four basic types of antenna in radar level measurement, horn, parabolic, rod, and waveguide.

attenuation

a term used to denote a decrease in signal magnitude in transmission from one point to another. Attenuation may be expressed as a scalar ratio of the input magnitude to the output magnitude or in decibels.

Auto False-Echo Suppression

a technique used to adjust the level of a TVT to avoid the reading of false echoes. (See TVT.)

Auto-False Echo Suppression Distance

defines the endpoint of the TVT distance. (See TVT.) This is used in conjunction with auto false echo suppression.

beam angle

the angle diametrically subtended by the one-half power limits (-3 dB) of the microwave beam.

beam spreading

the divergence of a beam as it travels through a medium.

blanking

a blind zone extending away from the reference point plus any additional shield length. The device is programmed to ignore this zone.

capacitance

the property of a system of conductors and dielectrics that permits the storage of electricity when potential differences exist between the conductors. Its value is expressed as the ratio of a quantity of electricity to a potential difference, and the unit is a Farad.

confidence

see Echo Confidence.

damping

term applied to the performance of a device to denote the manner in which the measurement settles to its steady indication after a change in the value of the level.

dB (decibel)

a unit used to measure the amplitude of signals.

derating

to decrease a rating suitable for normal conditions according to guidelines specified for different conditions.

dielectric

a nonconductor of direct electric current. Many conductive liquids/electrolytes exhibit dielectric properties; the relative dielectric constant of water is 80.

dielectric constant (dK)

the ability of a dielectric to store electrical potential energy under the influence of an electric field. Also known as Relative Permittivity. An increase in the

dielectric constant is directly proportional to an increase in signal amplitude. The value is usually given relative to a vacuum /dry air: the dielectric constant of air is 1.

echo

a signal that has been reflected with sufficient magnitude and delay to be perceived in some manner as a signal distinct from that directly transmitted. Echoes are frequently measured in decibels relative to the directly transmitted signal.

Echo Confidence

describes the quality of an echo. Higher values represent higher quality. Echo Threshold defines the minimum value required for an echo to be accepted as valid and evaluated.

Echo Lock Window

a window centered on an echo in order to locate and display the echo's position and true reading. Echoes outside the window are not immediately processed.

Echo Marker

a marker that points to the processed echo.

Echo Processing

the process by which the radar unit determines echoes.

Echo Profile

a graphical display of a processed echo.

Echo Strength

describes the strength of the selected echo in dB referred to 1 μ V rms.

false Echo

any echo which is not the echo from the desired target. Generally, false echoes are created by vessel obstructions.

frequency

the number of periods occurring per unit time. Frequency may be stated in cycles per second.

hertz (Hz):

unit of frequency, one cycle per second. 1 Gigahertz (GHz) is equal to 10^9 Hz.

horn antenna

a conical, horn-shaped antenna which focuses microwave signals. The larger the horn diameter, the more focused the radar beam.

inductance

the property of an electric circuit by virtue of which a varying current induces an electromotive force in that circuit or in a neighboring circuit. The unit is a Henry.

microwaves

the term for the electromagnetic frequencies occupying the portion of the radio frequency spectrum from 1 GHz to 300 GHz.

multiple echoes

secondary echoes that appear as double, triple, or quadruple echoes in the distance from the target echo.

Near Blanking

see Blanking.

nozzle

a length of pipe mounted onto a vessel that supports the flange.

parameters

in programming, variables that are given constant values for specific purposes or processes.

polarization

the property of a radiated electromagnetic wave describing the time-varying direction and amplitude of the electric field vector.

polarization error

the error arising from the transmission or reception of an electromagnetic wave having a polarization other than that intended for the system.

PROFIBUS PA

one of the PROFIBUS family of protocols, specifically tailored for the needs of process industries (PA = Process Automation).

propagation factor (pf)

where the maximum velocity is 1.0, pf is a value that represents a reduction in propagation velocity as a result of the wave travelling through a pipe or medium.

pulse radar

a radar type that directly measures distance using short microwave pulses. Distance is determined by the return transit time.

radar

radar is an acronym for RAdio Detection And Ranging. A device that radiates electromagnetic waves and utilizes the reflection of such waves from distant objects to determine their existence or position.

range

distance between a transmitter and a target.

range extension

the distance below the zero percent or empty point in a vessel.

relative permittivity

see dielectric constant.

repeatability

the closeness of agreement among repeated measurements of the same variable under the same conditions.

shot

one transmit pulse or measurement.

speed of light

the speed of electromagnetic waves (including microwave and light) in free space. Light speed is a constant 299, 792, 458 meters per second.

stilling-well

see stillpipe.

stillpipe

a pipe that is mounted inside a vessel parallel to the vessel wall, and is open to the vessel at the bottom.

TVT (Time Varying Threshold)

a time-varying curve that determines the threshold level above which echoes are determined to be valid.

two wire radar

a low-energy radar. Can be loop powered, analog, intrinsically safe 4 to 20 mA, or a digital (BUS) transmitter.

waveguide antenna

a hollow, metallic tube that transmits a microwave signal to the product target.

Index

A

- Abbreviations and identifications list, 291
- access control
 - local access, 166
 - remote access, 166
- Acknowledge Faults
 - via PDM, 93
- activating SITRANS LR250, 54
- acyclic diagnostics
 - fault codes, 282
- agitator blade detection
 - avoiding, 126
- antenna
 - replacement, 175
- antenna types
 - flanged encapsulated antenna, 205, 207
 - flanged horn antenna, 201
 - flanged horn antenna with extension, 203
 - threaded horn, 195
 - threaded PVDF antenna, 227
- Auto False Echo Suppression
 - explanation, 246
 - setup, 128
 - setup via LUI, 130
 - TVT Shaper adjustment, 86
 - via PDM, 85, 88

B

- beam angle
 - flanged encapsulated antenna, 205, 207
 - flanged horn, 201, 203
 - threaded horn, 197, 199
 - threaded PVDF antenna, 227
- blanking (see Near Range), 248
- bolting instructions, 37
- bus address (device address)
 - resetting to 126, 276
- bus termination, 276
- bypass pipe
 - see stillpipe, 32

C

- cables
 - requirements, 42
- Calibration Interval, 161
- calibration schedules via PDM, 91
- cleaning
 - instructions, 173
- CLEF (Constrained Leading Edge Fit)
 - explanation, 244
- CLEF range
 - setup, 125
- Condensed Status
 - explanation, 280
- conduits
 - requirements, 42
- configuration
 - network, 275
 - new device via PDM, 77
 - PLC with PROFIBUS PA, 44
 - Quick Start via LUI, 63
- Correct usage, (See improper device modifications)
- cyclic data
 - versus acyclic data, 278

D

- damping
 - Filter Time Constant setup, 136
- Damping
 - explanation, 249
- data logging
 - time-based echo profile storage, 86
- Device Address, 165
 - reset via LUI, 67
- device description
 - Electronic Device Description, 275
- Device Description (DD)
 - see EDD, 76
- device nameplate
 - Intrinsically Safe (FM/CSA), 47
- device nameplate
 - FM/CSA Class 1 Div. 2 28, 49

- Intrinsically Safe (ATEX/IECEX), 46
- Device Reset
 - see Master Reset, 146
- Device Status
 - icons, 180
 - view via PDM, 101
- diagnosis reply, 282
- Diagnostics
 - maintenance settings, 138
 - via PDM, 98
- dimensions
 - flanged encapsulated antenna, 205, 207
 - flanged horn, 201, 203
 - flat face flange, 234
 - raised face flange**, 229, 231
 - threaded horn with extension, 197, 199
 - threaded PVDF antenna, 227
- E**
- echo confidence
 - parameter setup, 127
- echo processing
 - Process Intelligence, 242
- Echo Profile
 - data logging, 86
 - view via LUI, 66
 - view via PDM, 85
- Echo Profile Utilities
 - Auto False Echo Suppression, 84
 - Echo Profile, 84
 - TVT Shaper, 84
- echo selection
 - Algorithm, 243
 - CLEF (Constrained Leading Edge Fit), 244
 - Position Detect, 243
 - time varying threshold (TVT), 242
- Echo Setup
 - quick access via PDM, 91
- EDD
 - updating, 77
- EDD (electronic device description), 275
- edit mode
 - handheld programmer, 59
 - key functions, 62
- Electronic Device Description (EDD)
 - required for PROFIBUS PA, 76

- updating, 77
- Empty rate
 - setup, 115
- enable/disable local operation, 166
- enable/disable remote operation, 166
- enclosure
 - opening, 43

F

- factory defaults
 - Master Reset, 146
- Factory Defaults
 - reset via PDM, 97
- Fail-safe
 - Behavior explanation, 250
 - Mode explanation, 250
 - Value explanation, 251
- Fail-safe Mode FB1
 - setup, 137
- false echo
 - see Auto False Echo Suppression, 246
- Far Range
 - explanation, 248
 - setup, 121
- fault codes
 - acyclic diagnostics, 282
 - acyclic extended diagnostics, 285
 - general fault codes, 181
- Fill Rate
 - setup, 114
- Filter Time Constant
 - explanation, 249
- flange
 - bolting instructions, 37
- flange markings
 - flat face, 234
 - raised face, 229, 232
- flange sizes**
 - flat face, 234
 - raised face**, 229, 231
- flanged encapsulated antenna
 - dimensions, 207
- flanged horn
 - dimensions, 201, 203
- Function Blocks
 - view process variables via PDM, 99

function keys
 edit mode, 62
 navigation mode, 59
Function keys
 measurement mode, 57

G

GSD file, 276

H

handheld programmer
 edit mode, 60, 62
 measurement mode, 57
 navigation, 59
 programming, 58
hazardous area installations
 instructions, 50
 wiring requirements, 45
hysteresis
 setup, 136

I

Identifications and abbreviations
 list, 291
Improper device modifications, 16
installation
 hazardous area requirements, 45
 requirements, 34
 warnings and notes, 34
internal temperature
 monitoring, 251

K

key functions
 edit mode, 62
 navigation mode, 59

L

Language, 167
LCD display

 contrast adjustment, 164
 echo profile viewing, 66
 fast mode, 164
 measurement mode, 55
lens
 replacement, 175
lid-lock set screw, 43
Limit Hysteresis
 setup, 136
Lithium batteries
 Safety, 53
Local Operation
 enable/disable, 166
Local User Interface (LUI), 55
LOE Timer
 explanation, 250
 setup, 111
loop voltage vs. loop resistance
 power supply requirements, 47
loss of echo (LOE)
 explanation, 250
Loss of Echo (LOE)
 explanation, 250
LUI (Local User Interface)
 contrast adjustment, 55

M

maintenance
 calibration schedules, 92
 repairs, 173
 replacing antenna, 175
 replacing lens, 175
 service schedules, 92
Maintenance, 174
maintenance settings
 Calibration Interval, 161
 see Diagnostics, 138
 see Remaining Sensor Lifetime, 153
 Service Interval, 156
Master Reset
 factory defaults, 146
 reset PROFIBUS address (to 126), 146
 standard defaults, 146
Measurement Response
 explanation, 249
mounting

- bypass requirements, 32
- handheld programmer access, 30
- housing construction, 24, 31
- nozzle design, 27, 253
- nozzle location, 28, 253
- on vessel with obstructions, 31
- sunshield recommended, 31

N

- nameplate
 - Intrinsically Safe (ATEX/IECEX), 46
 - Intrinsically Safe (FM/CSA), 47
- Near Range
 - explanation, 248
 - setup, 121

O

- operating principles
 - cleaning, 241
- Operation
 - level, distance, space, 108
- Output limits
 - setup, 135
- Output Scale
 - setup, 134
- overview, 19

P

- parameters
 - reset via PDM, 83
- password protection
 - via PDM, 104
- PDM
 - see SIMATIC PDM, 75
- peak values
 - electronics temperature, 102
 - sensor peak values FB1 and FB2, 103
- PED (Pressure Equipment Directive), 23, 253
- performance
 - specifications, 187
- pipe sizes**
 - flange mounting**, 229, 231
- polarization reference point, 31

- power consumption, 276
- power source
 - requirements, 41
- pressure applications, 23
 - Pressure Equipment Directive, 23, 253
- Process Intelligence, 242
- process temperature
 - maximum, 251
- Process Variables
 - view via PDM, 98
- PROFIBUS address
 - reset to 126, 146
- PROFIBUS address 145, 276
- PROFIBUS Ident Number, 165
- programmer
 - handheld, 57
- programming
 - adjust parameters via PDM, 83
 - via the handheld programmer, 58
- programming LR250
 - enter program mode, 59
 - via handheld programmer, 59
- propagation factor
 - values, 122

Q

- Qualified personnel, 17
- Quick Start Wizard
 - via LUI, 63
 - via SIMATIC PDM, 78

R

- raised face flange markings, 228, 230
- reading erratic
 - troubleshooting, 185
- reading incorrect
 - troubleshooting, 185
- reading response slow, 185
- Remote Lockout, 166
- repair
 - cautions, 175
 - excluded liability, 175
- reset
 - see Master Reset, 146
- Response Rate

explanation, 249
setup, 114

S

Scope of delivery, 11
sensor reference point
 flanged encapsulated antenna, 205, 207
 flanged horn, 201, 203
 flat faced flange, 234
 raised face flange, 228, 230
 threaded horn, 197, 199
 threaded PVDF horn, 227
Service Interval, 156
service schedules via PDM, 91
settings
 adjust parameters via LUI, 62
 adjust parameters via PDM, 58, 83
sidepipe
 see bypass pipe, 32
SIMATIC PDM
 functions and features, 75
 overview, 275
 Rev 5.2, SP1 features, 76
 Rev 6.0, SP4 features, 76
Simulate Analog Input
 via PDM, 94
Simulate Input
 via PDM, 96
Simulate Output
 via PDM, 95
Simulation
 via PDM, 93
SITRANS LR250
 operating principles, 241
startup
 transition screen, 54
status byte
 status codes, 279
status codes, 279
stillpipe
 mounting requirements, 32
Support
 contact information, 289

T

technical data, 187
 ambient temperature, 192
 antenna, 190
 enclosure, 190
 environmental, 192
 performance, 187
 pressure, 192
 process connections, 189
 process temperature, 192
 weight, 190
technical support
 contact information, 289
temperature de-Rating
 curves, 253
threaded connection markings, 227
threaded horn antenna
 dimensions, 197, 199
threaded PVDF antenna
 dimensions, 227
trend view
 via PDM, 100
troubleshooting
 communication, 179
 operation, 184
TVT (time varying threshold)
 explanation, 242
TVT Shaper
 manual adjustment via PDM, 87
 via PDM, 84

V

vessel shape
 selection, 116

W

Wear
 powered hours, 93
 poweron resets, 93
 view via PDM, 93
wiring
 cables, 42
 hazardous areas, 45
Write Locking
 via PDM, 96
Write Protection, 166

