

sitrans

LR 400

million
in one

SIEMENS

DRAFT

Safety Guidelines: Warning notices must be observed to ensure personal safety as well as that of others, and to protect the product and the connected equipment. These warning notices are accompanied by a clarification of the level of caution to be observed.

Qualified Personnel: This device/system may only be set up and operated in conjunction with this manual. Qualified personnel are only authorized to install and operate this equipment in accordance with established safety practices and standards.

Unit Repair and Excluded Liability:

- The user is responsible for all changes and repairs made to the device by the user or the user's agent.
- All new components are to be provided by Siemens Milltronics Process Instruments Inc.
- Restrict repair to faulty components only.
- Do not reuse faulty components.

Warning: This product can only function properly and safely if it is correctly transported, stored, installed, set up, operated, and maintained.

Note: Always use product in accordance with specifications.

Copyright Siemens Milltronics Process Instruments Inc. 2004. All Rights Reserved	Disclaimer of Liability
This document is available in bound version and in electronic version. We encourage users to purchase authorized bound manuals, or to view electronic versions as designed and authored by Siemens Milltronics Process Instruments Inc. Siemens Milltronics Process Instruments Inc. will not be responsible for the contents of partial or whole reproductions of either bound or electronic versions.	While we have verified the contents of this manual for agreement with the instrumentation described, variations remain possible. Thus we cannot guarantee full agreement. The contents of this manual are regularly reviewed and corrections are included in subsequent editions. We welcome all suggestions for improvement. Technical data subject to change.

MILLTRONICS® is a registered trademark of Siemens Milltronics Process Instruments Inc.

Contact SMPI Technical Publications at the following address:

Technical Publications
Siemens Milltronics Process Instruments Inc.
1954 Technology Drive, P.O. Box 4225
Peterborough, Ontario, Canada, K9J 7B1
Email: techpubs.smpi@siemens.com

- For a selection of Siemens Milltronics level measurement manuals, go to: **www.siemens.com/processautomation**. Under Process Instrumentation, select *Level Measurement* and then go to the manual archive listed under the product family.
- For a selection of Siemens Milltronics weighing manuals, go to: **www.siemens.com/processautomation**. Under Weighing Technology, select *Continuous Weighing Systems* and then go to the manual archive listed under the product family.

General Information	1
Safety Notes	1
The Manual	1
Abbreviations and Identifications	2
SITRANS LR 400	3
Structure	3
System Implementation	5
Specifications	6
SITRANS LR 400	6
Dimensions	11
Purging System	17
Installation	18
Mounting Location	18
Beam Spreading	19
Correct Installation in Mounting Nozzle	19
Installation using Easy Aimer LR	19
Electrical Connection	20
Start Up	22
Self-test	22
Multi-display	22
Local Programming	22
Auto-Setup	22
Operation	24
General Information	24
Measuring Principle	24
Operating the SITRANS LR 400	26
Selecting a Parameter	26
Structure of Parameters	27
Changing a Parameter Value	27
Disabling and Enabling Programming	29
Operating Examples	30
Parameters (HART)	32
Functional Dimensions	33
Required Parameters	33
Additional Parameters	35
Parameters (PROFIBUS PA)	63
Troubleshooting	75
Classification of Faults	75

Self-test	75
Symptoms, Causes and Their Remedy	75
Fault Messages	76
Unit Repair and Excluded Liability	77
Maintenance	78
Cleaning the Antenna	78
Glossary	79
Appendix I: Parameter List	80
Appendix II: Programming Chart	84
Appendix III	88
Ambient/Operating Temperature Specification	88
Appendix IV	90
Process Pressure/Temperature De-rating	90
Appendix V	92
HART Communications for the SITRANS LR 400	92
HART Device Descriptor (DD)	92
SIMATIC Process Device Manager (PDM):	92
HART Communicator 275:	93
Appendix VI	98
PROFIBUS PA Communications for the SITRANS LR 400	98
Device Descriptor	98
The GSD file	98
Bus address (Device Address)	98
Power Demands	99
Cyclic versus Acyclic Data	99
Cyclic Data	99
Status Word	101
Extended Diagnostics	102
Acyclic Data	102
Configuration Example:	102
Hazardous Installation	103

DRAFT

General Information

Safety Notes

Special attention must be paid to warnings and notices highlighted from the rest of the text by grey boxes.



WARNING: relates to a caution symbol on the product, and means that failure to observe the necessary precautions can result in death, serious injury, and/or considerable material damage.



WARNING: means that failure to observe the necessary precautions can result in death, serious injury, and/or considerable material damage.

CAUTION: means that failure to observe the necessary precautions can result in considerable material damage.

Note: means important information about the product or that part of the operating manual.

- These instructions do not claim to cover all details or variations in equipment, or to provide for every possible contingency that may arise during installation, operation, or maintenance.
- For further information or to resolve issues not covered in the manual, consult your Siemens Milltronics representative.

The Manual

IMPORTANT: All specifications are subject to change without notice. Please ensure that any safety-related information is confirmed with a qualified Siemens Milltronics representative.



WARNINGS:

- Changes or modifications not expressly approved by Siemens Milltronics could void the user's authority to operate the equipment.
- This equipment is intended to be used only in fully enclosed metal and concrete containers.

Note: This equipment has been tested and found to comply with the limits for a Class A digital device, pursuant to Part 15 of the FCC Rules. These limits are designed to provide reasonable protection against harmful interference when the equipment is operated in a commercial environment. This equipment generates, uses, and can radiate radio frequency energy and, if not installed and used in accordance with the instruction manual, may cause harmful interference to radio communications.

Operation of this equipment in a residential area is likely to cause harmful interference in which case the user will be required to correct the interference at his own expense.

This manual will help you set up your SITRANS LR 400 for optimal performance. We always welcome suggestions and comments about manual content, design, and accessibility.

Please direct your comments to techpubs.smpi@siemens.com. For the complete library of Siemens Milltronics manuals, go to www.siemens.com/processautomation



WARNINGS:

- Installation shall only be performed by qualified personnel and in accordance with local governing regulations.
- The SITRANS LR 400 is to be used only in the manner outlined in this manual, otherwise protection provided by equipment may be impaired.

Qualified personnel

Qualified personnel are familiar with the installation, commissioning, and operation of this equipment. In addition the person must be:

- trained and authorized to operate and service equipment/systems in accordance with established safety procedures relating to electrical circuits, high pressures and aggressive media.
- trained in the proper care and use of protective equipment in accordance with established safety practices.
- trained in rendering first aid.

Abbreviations and Identifications

Short form	Long form	Description
CE / FM / CSA	Conformité Européene / Factory Mutual / Canadian Standards Association	safety approval
ESD	Electrostatic Discharge	
HART®	Highway Addressable Remote Transducer	
IS	Intrinsically Safe	safety approval
PED	Pressure Equipment Directive	safety approval

HART is a registered trademark of the HART Communication Foundation.

SITRANS LR 400

The SITRANS LR 400 is a long-range FMCW radar level instrument. A liquids version (L) is available for use in liquids storage, performing well on low dielectric liquids or sticky materials requiring a purging unit. A solids version (S) incorporates the Easy Aimer design for use in solids, especially conditions of extreme dust. On both versions, the narrow antenna beam results in a sharp radiation cone, which makes the SITRANS LR 400 quite insensitive to vessel interferences.

Structure

Liquids Version

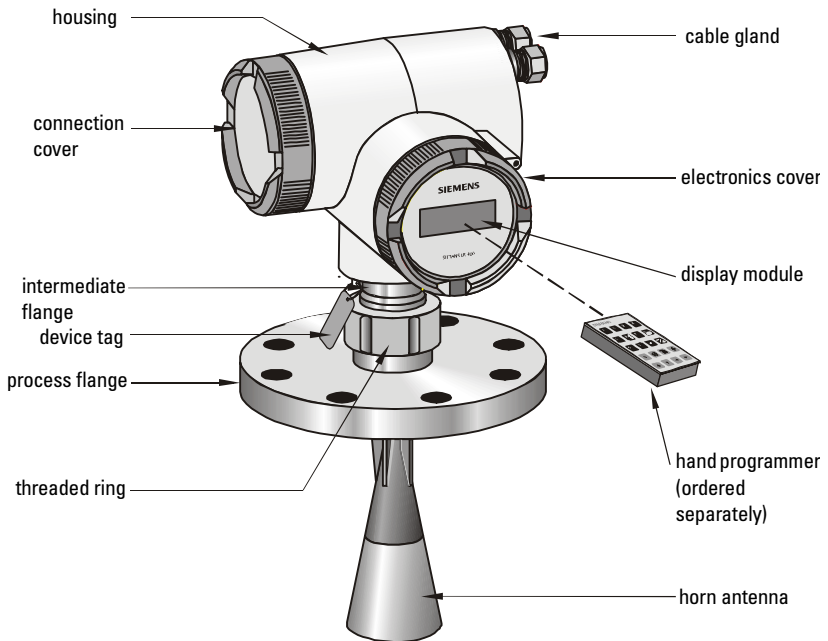

DRAFT

Solids Version

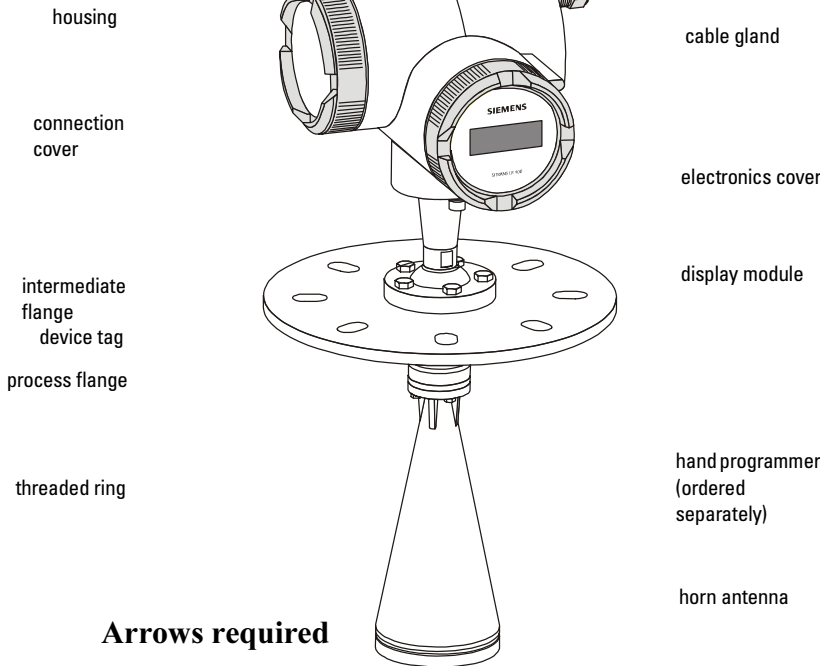

The terminals for the power cable and the signal cable are behind the connection cover on the left side of the housing. The signal cable must be fed in from the right through the cable glands.

The end of the antenna must reach inside the vessel through the vessel nozzle (see page 19).

If the device is rotated, return the orientation of the housing to its previous position with reference to the flange, to ensure similar performance.

System Implementation

SITRANS LR 400 supports HART communication protocol, and SIMATIC PDM software.

Typical PLC/mA configuration with HART

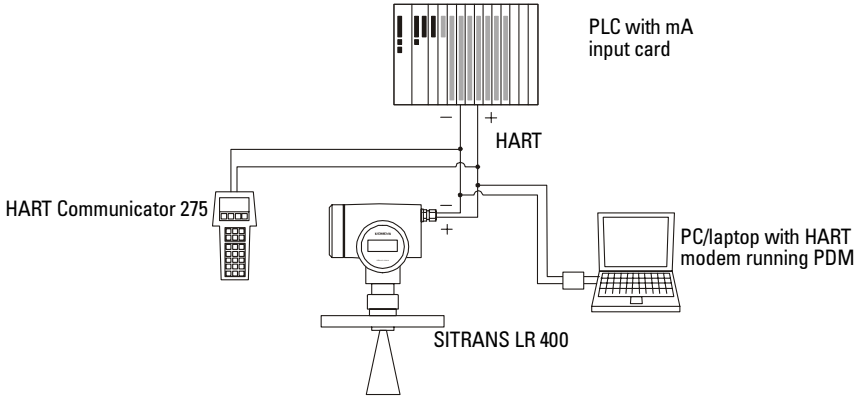

Note: A 250 ohm loop resistor may be required, depending on PLC input resistance.

Typical PLC/mA configuration with PROFIBUS PA

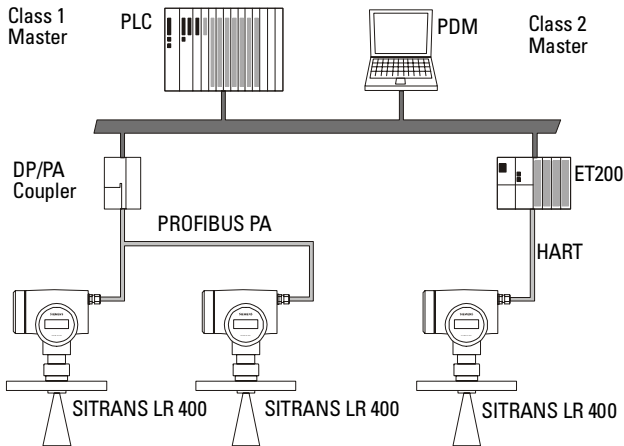

Specifications

Note: Siemens Milltronics makes every attempt to ensure the accuracy of these specifications, but reserves the right to change them at any time. Please ensure these are the most recent specifications. Contact your representative, or check our web site at www.siemens.com/milltronics for the most up-to-date information.

SITRANS LR 400

Power

- Power Supply 120 to 230 V AC, $\pm 15\%$, 50/60 Hz, 6W (12VA) or 24 V DC, +25/-20%, 6W
Power failure: bridge of at least 1 mains period (> 20 ms)

Fuse

- Fuse (both AC and DC versions)

SI1	Fast acting ceramic, 4 x 20 mm, 1A, 250 V AC
SI2	Slow-Blow, 4 x 20 mm, 0.63 A, 250 V AC

Performance

Measured value error (under reference conditions)

- Measuring error $\leq \pm 5$ mm at 1 to 10 m distance
 $\leq \pm 15$ mm at 10 to 45 m distance
- Dead zone 0 to 350 mm from bottom edge of flange
- Additional contribution of analog output $\leq 0.1\%$ of the measured value
 $\leq 0.05\%$ of full scale
- Long-term stability $\leq \pm 1$ mm/year
- Repetitive accuracy $\leq \pm 1$ mm at 0 to 45 m, damping ≥ 1 s

Interface

- Analog output (Not applicable to PROFIBUS PA option)

Signal range	4 to 20 mA
Upper Limit	20 to 22.5 mA adjustable
Fail signal	3.6 mA; 22 mA; 24 mA or last value
Load	Max. 600 Ω ; for HART [®] ¹ communication min. 230 Ω
- Digital output

Function	Configurable as a device status or limit value (level, volume, mass)
----------	--

¹ HART is a registered trademark of HART Communication Foundation.

Signal type	Relay, either NCC or NOC function max. 50 V DC, max. 200 mA, rating max. 5 W. Self-resetting fuse, $R_i = 9 \Omega$
• Electrical isolation	Outputs electrically isolated from the power supply and from each other
• Display	LCD, two lines of 16 characters each, configurable for the following displays: level, volume, mass, amplitude, digital output, temperature, validity, signal-to-noise ratio
	Multi-display: 2 freely selectable measured values are displayed simultaneously

Programmer (infrared keypad)

Siemens Milltronics Infrared IS (Intrinsically Safe) Hand Programmer for hazardous and all other locations (battery is non-replaceable)

- approval: ATEX II 1 G, EEx ia IIC T4, certificate SIRA 01ATEX2147
CSA and FM Class I, Div. 1, Gr. A, B, C, D T6 @ max. ambient temperature of 40 °C (104 °F)
- ambient temperature: –20 to 40 °C (–5 to 104 °F)
- interface: proprietary infrared pulse signal
- power: 3 V lithium battery
- weight: 150 g (0.3 lb)
- color: black

Mechanical Flange

- Process Connection Flange DIN 2527, ANSI B16.5, or JIS B2238 equivalent bolt pattern
- Materials of the wetted parts – in contact with the process Stainless steel flange and horn, PTFE emitter (or glass/PTFE, Zone 0 and Zone 20 devices)
- Pressure (vessel) Varies with connection type. Refer to Appendix IV for specifications.
Solids version (including integral Easy Aimer) is rated at 0.5 bar (7.5 psi) maximum.

Weight

- Weight of instrument and flange

Process Connection	Weight
Universal, 2" / 50 mm, flat faced, 0.5 bar maximum	5.3 kg (11.7 lbs)
Universal, 3" / 80 mm, flat faced, 0.5 bar maximum	6.1 kg (13.4 lbs)
Universal, 4" / 100 mm, flat faced, 0.5 bar maximum	6.8 kg (15.0 lbs)
Universal, 6" / 150 mm, flat faced, 0.5 bar maximum	8.5 kg (18.7 lbs)
DN80 PN16, flat faced	11.9 kg (26.1 lbs)
DN80 PN40, flat faced	12.9 kg (28.4 lbs)
DN100 PN16, flat faced	13.2 kg (34.1 lbs)
DN100 PN40, flat faced	15.5 kg (34.1 lbs)
DN150 PN16, flat faced	19.2 kg (42.1 lbs)
DN150 PN40, flat faced	24.1 kg (43.1 lbs)
3", 150 lb class, raised faced	12.2 kg (26.8 lbs)
3", 300 lb class, raised faced	14.3 kg (31.5 lbs)
4", 150 lb class, raised faced	14.8 kg (32.5 lbs)
4", 300 lb class, raised faced	20.2 kg (44.4 lbs)
6", 150 lb class, raised faced	20.1 kg (44.2 lbs)
6", 300 lb class, raised faced	31.8 kg (69.9 lbs)
JIS DN80 10K, flat faced	11.9 kg (26.1 lbs)
JIS DN100 10K, flat faced	13.2 kg (28.9 lbs)
JIS DN150 10K, flat faced	19.2 kg (42.1 lbs)
Easy Aimer with purge option	11.8 kg (26 lbs)

Note: Please ensure these are the most recent specifications. Contact your Siemens Milltronics representative, or check our web site at www.siemens.com/milltronics for the most up-to-date information.

! **WARNING:** This product is designated as a Pressure Accessory per Directive 97/23/EC and is not intended for use as a safety device.

Enclosure

- construction Die-cast aluminum, painted
- conduit 2 x M20
or 2 x 1/2" NPT
- ingress protection Type 4X/NEMA 4X, Type 6/NEMA 6, IP67¹

Environmental²

- location: indoor/outdoor
- altitude: 2000 m max
- ambient temperature: -40 to 65 °C (-40 to 149 °F)
- relative humidity: suitable for outdoor (Type / NEMA 4X, 6/ IP67)
- installation category II
- pollution degree 4
- Process Temperature -40 to 200 °C (-40 to 392 °F)
- Optional (Liquids version) -40 to 250 °C (-40 to 482 °F)

1. Use only approved, suitable sized hubs for watertight applications.
2. See Process/Ambient de-rating curves in Appendix III.

- Electromagnetic compatibility
 - Spurious emission according to EN 50 081
 - Interference strength according to EN 50 082
- Perm. ambient temperature
 - 40 to 65 °C (-40 to 149 °F) (non-hazardous version)
 - LCD: -10 to 55 °C (14 to 131 °F)
 - Observe the temperature classes in hazardous areas!



WARNING: Materials of construction are chosen based on their chemical compatibility (or inertness) for general purposes. For exposure to specific environments, check with chemical compatibility charts before installing.

Communication

- Communication: HART
 - Load 230 to 600 Ω , 230 to 500 Ω when connecting a coupling module
 - Line two-wire shielded: ≤ 3 km
multi-wire shielded: ≤ 1.5 km
 - Protocol HART, Version 5.1
- Communication: PROFIBUS PA
 - Protocol Layer 1 and 2 PROFIBUS PA, technology: IEC 61158-2, slave-functionality
 - Device Class A
 - Device Profile 3.0
- PC/Laptop requirements
 - IBM-compatible
 - RAM ≥ 64 Mbytes
 - Hard disk ≥ 100 Mbytes
 - RS 232-C interface
 - VGA graphic card ($\geq 640 \times 480$)
- Software for PC/Laptop
 - Windows 95/98/2000/XP or NT 4.0
 - SIMATIC® PDM

DRAFT

Approvals (verify against device nameplate)

- Explosion Protection (Liquids)Certificate No. PTB 00 ATEX 1024
*Refer to device nameplate II 1/2G EEx d IIC T6II 2G EEx d IIC T6
II 1/2G EEx dem IIC T6II 2G EEx dem IIC T6
II 1/2G EEx dem [ib] IIC T6II 2G EEx dem [ib] IIC T6
II 1/2G EEx dem [ia] IIC T6II 2G EEx dem [ia] IIC T6
FM/CSA Class I, Div. 1, Groups B, C, D; Class II/III, Div. 1, Groups E, F, G
- Explosion Protection (Solids)FM/CSA Class II, Div. 1, Groups B, C,D; Class II/III, Div. 1, Groups E,F and G
Certificate No. DMT 01 ATEX E 038
II 1/2 D IP 65 (dust zone 20, zone 21 approval)
- General CSAus/c, FM
- Radio FCC, Industry Canada, European Radio
- Shipping (Liquids version) Lloyd's Register of Shipping, Categories ENV1, ENV2, ENV3, and ENV5

! **WARNING:** This product is designated as a Pressure Accessory per directive 97/23/EC and is not intended for use as a safety device.

Note: Please ensure these are the most recent specifications. Contact your Siemens Milltronics representative, or check our web site at www.siemens.com/milltronics for the most up-to-date information.

Dimensions

SITRANS LR 400 Version for Liquids (without Temperature Extension)

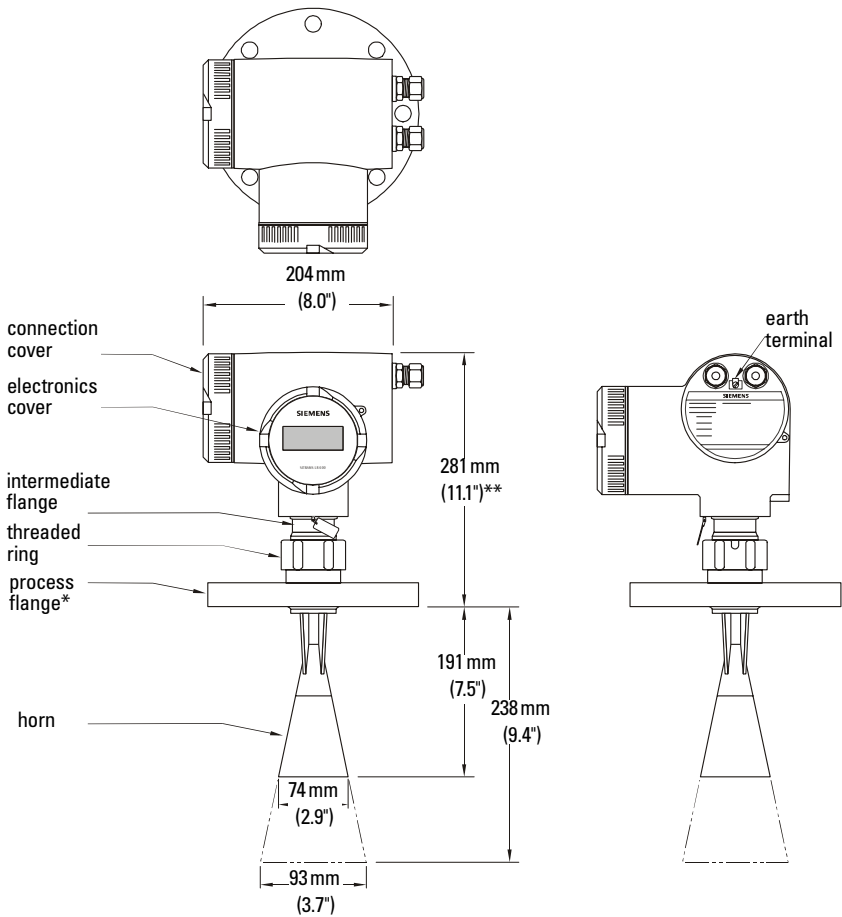

Note: Process temperature and pressure capabilities are dependent upon information on the process device tag. See Appendix IV (Process Pressure/Temperature de-Rating). Reference drawing listed on the tag is available upon request.

! **WARNING:** The user is responsible for the selection of bolting and gasket materials which will fall within the limits of the flange and its intended use and which are suitable for the service conditions.

*Flange acc. to DIN 2527 / ANSI B16.5 / JIS B2238 bolt hole pattern

**An optional purging system can be installed between the flange and the horn antenna. The system provides a 1/8" NPT inlet on the flange where cooling air or cleaning fluid passes through the universal flange and exits the inside of the horn to clean it. The customer will supply the purging medium by manual or automatic valve system. This option is only available with universal flanges.

SITRANS LR 400 Version for Liquids with optional Temperature Extension

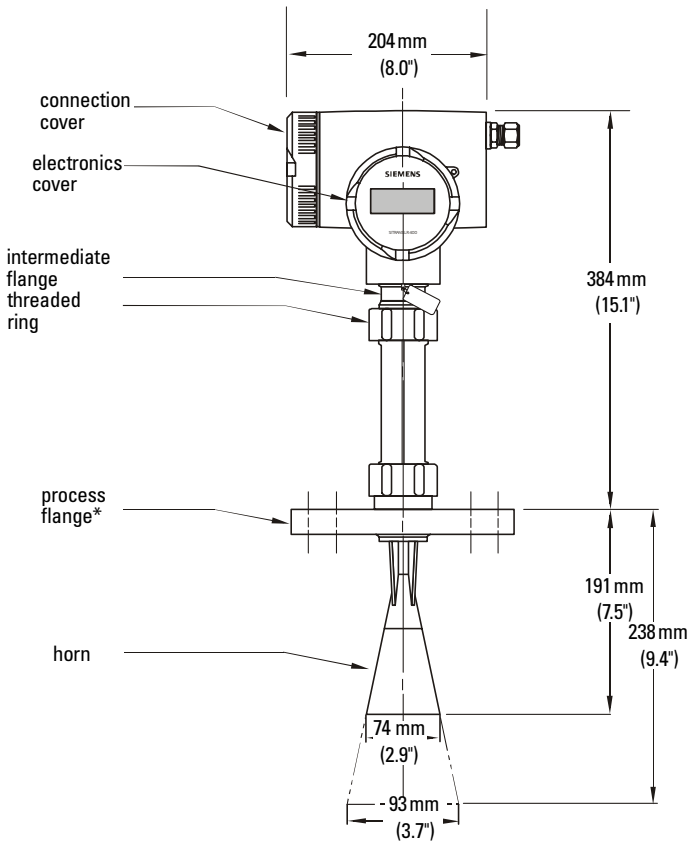

*Flange acc. to DIN 2527 / ANSI B16.5 / JIS B2238 bolt hole pattern

Note: Process temperature and pressure capabilities are dependent upon information on the process device tag. See Appendix IV (Process Pressure/Temperature de-Rating). Reference drawing listed on the tag is available upon request.

! **WARNING:** The user is responsible for the selection of bolting and gasket materials which will fall within the limits of the flange and its intended use and which are suitable for the service conditions.

SITRANS LR 400 Version for Solids

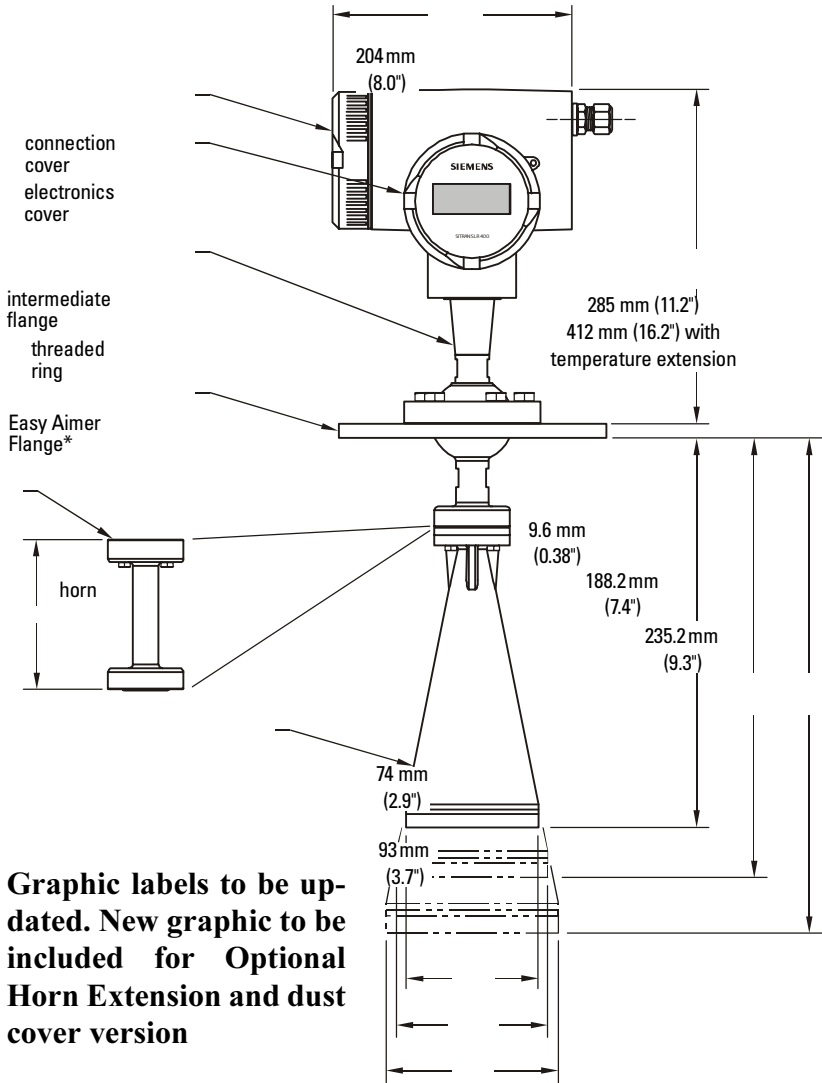

*Flange acc. to DIN 2527 / ANSI B16.5 / JIS B2238 bolt hole pattern

! **WARNING:** The user is responsible for the selection of bolting and gasket materials which will fall within the limits of the flange and its intended use and which are suitable for the service conditions.

DRAFT

DIN / JIS Flat Face Flange Diagram (for Liquids version only)

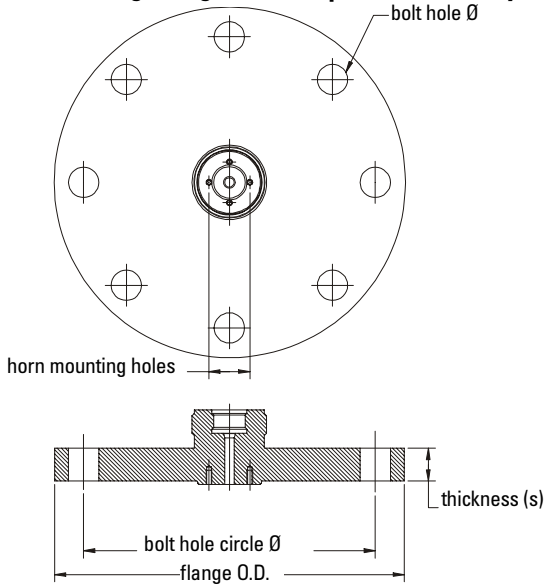

Flange according to DIN 2527 (see Flange Diagram above)

Pipe Size	Flange Size	Flange O.D.	Thickness (s)	Bolt Hole Circle Ø	Bolt Hole Ø	Number of Bolts
80 mm	PN 16	200 mm	20.0 mm	160 mm	18.0 mm	8
100 mm	PN16	220 mm	20.0 mm	180 mm	18.0 mm	8
150 mm	PN 16	285 mm	22.0 mm	240 mm	22.0 mm	8
80 mm	PN 40	200 mm	24.0 mm	160 mm	18.0 mm	8
100 mm	PN 40	235 mm	24.0 mm	190 mm	22.0 mm	8
150 mm	PN 40	300 mm	28.0 mm	250 mm	26.0 mm	8

Flange according to JIS B 2238

Pipe Size	Flange Size	Flange O.D.	Thickness (s)	Bolt Hole Circle Ø	Bolt Hole Ø	Number of Bolts
80 mm	10 K	185 mm	20.0 mm	150 mm	19.0 mm	8
100 mm	10 K	210 mm	22.0 mm	175 mm	19.0 mm	8
150 mm	10 k	280 mm	24.0 mm	240 mm	23.0 mm	8

Note: Process temperature and pressure capabilities are dependent upon information on the process device tag. See Appendix IV (Process Pressure/ Temperature de-Rating). Reference drawing listed on the tag is available upon request.

! **WARNING:** The user is responsible for the selection of bolting and gasket materials which will fall within the limits of the flange and its intended use and which are suitable for the service conditions.

ANSI Raised Face Flange Diagram (for Liquids version only)

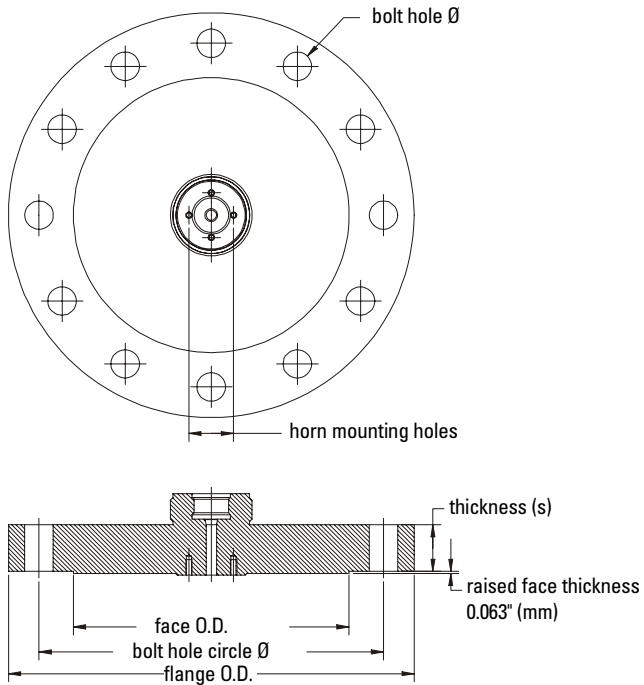

Flange according to ANSI B 16.5 (see Flange Diagram above)

Pipe Size	Flange Size	Flange O.D.	Thickness (s)	Face O.D.	Bolt Hole Circle Ø	Bolt Hole Ø	Number of Bolts
3"	150 #	7.50"	0.941"	5.0"	6.00"	0.75"	4
4"	150 #	9.00"	0.941"	6.19"	7.50"	0.75"	8
6"	150 #	11.00"	1.00"	8.5"	9.50"	0.88"	8
3"	300 #	8.25"	1.12"	5.0"	6.62"	0.88"	8
4"	300 #	10.00"	1.25"	6.19"	7.88"	0.88"	8
6"	300 #	12.51"	1.44"	8.5"	10.62"	0.88"	12

Note: Process temperature and pressure capabilities are dependent upon information on the process device tag. See Appendix IV (Process Pressure/Temperature de-Rating). Reference drawing listed on the tag is available upon request.

! **WARNING:** The user is responsible for the selection of bolting and gasket materials which will fall within the limits of the flange and its intended use and which are suitable for the service conditions.

Universal Slotted Flange Diagram

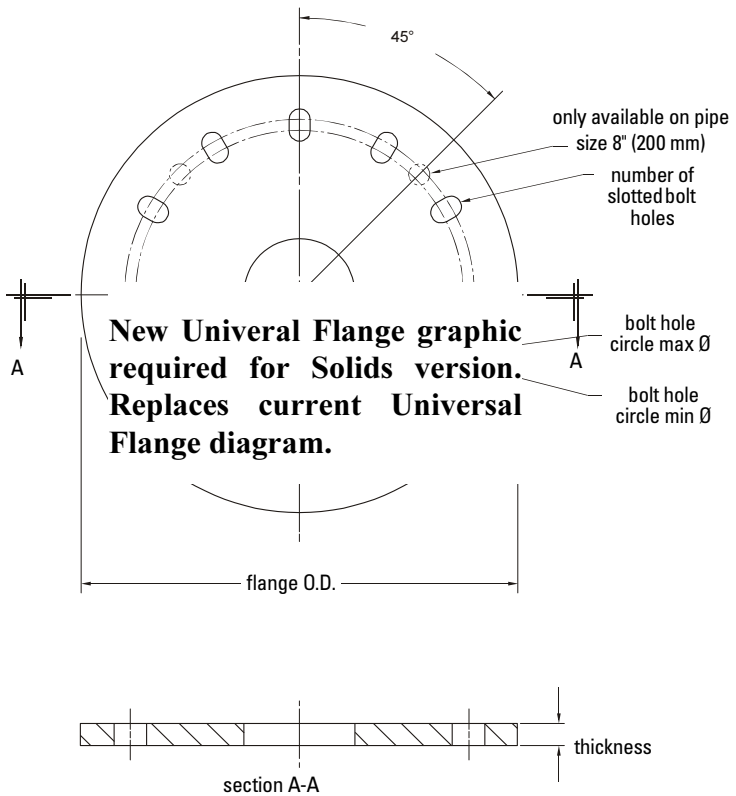

Flange according to Universal Slotted Flange (see Flange Diagram above)

Pipe Size	Flange O.D.	Thick-ness (s)	Bolt Hole Circle Max \varnothing	Bolt Hole Circle Min \varnothing	Bolt Hole radius	Number of Slotted Holes
3" or 80 mm	7.87"	0.40"	6.30"	5.90"	0.38"	8
4" or 100 mm	9.00"	0.40"	7.50"	6.89"	0.38"	8
6" or 150 mm	11.22"	0.40"	9.50"	9.44"	0.45"	8
8" or 200 mm	13.5"	0.40"	11.75"	11.4"	0.45"	12

! **WARNING:** The user is responsible for the selection of bolting and gasket materials which will fall within the limits of the flange and its intended use and which are suitable for the service conditions.

Purging System

For more frequent cleaning, a purging system can be installed between the flange and the horn antenna. The system provides an inlet on the flange where cooling air or cleaning fluid passes through the flange and exits the inside of the horn to clean it. The customer will supply the purging medium by manual or automatic valve system. This option is only available with universal flanges on the Liquids version of the SITRANS LR 400.

DRAFT

Installation

Notes:

- The SITRANS LR 400 is rated for Type 4X/NEMA 4X, Type 6/NEMA 6, IP67. Follow all installation and operating instructions to meet the requirements of this type of protection. Use only approved, suitable sized hubs for watertight applications.
- Observe all maximum permissible ambient and process temperatures. Refer to Appendix III (Ambient/Operating Temperature Specification).

Provide a warning sign and/or touch guard if the surface of the measuring instrument can become hotter than 70 °C in use.

! WARNINGS:

- This product is designated as a Pressure Accessory per directive 97/23/EC and is not intended for use as a safety device.
- Improper installation may result in loss of process pressure.

Mounting Location

- Do not mount in direct sunlight without the use of a sun shield. Refer to Appendix III (Ambient/Operating Temperature Specification) on page 88.
- Mount the unit more than 1 m away from the vessel walls, pipes and other assemblies as well as the filling stream, because all these influences will become noticeable as reflective interference. Align the antenna so that the radar cone intersects the surface of the measuring medium as vertically as possible

! **WARNING: For vessels with conical or parabolic tops, avoid mounting the unit at the center.** The concavity of the top can focus echoes into the centre, giving false readings.

Parabolic or Conical

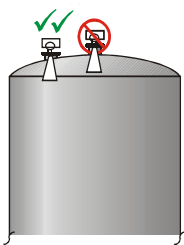

✓✓ is preferred location

Flat

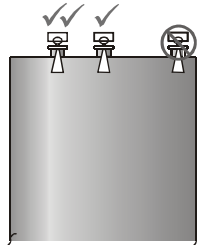

✓ is acceptable location

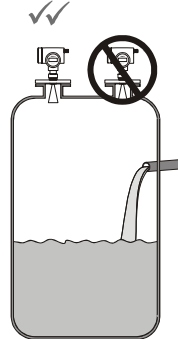

Easy Aimer

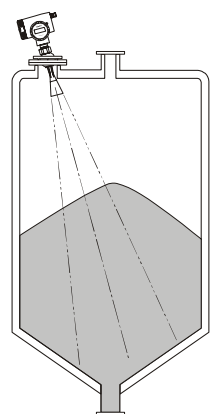

Beam Spreading

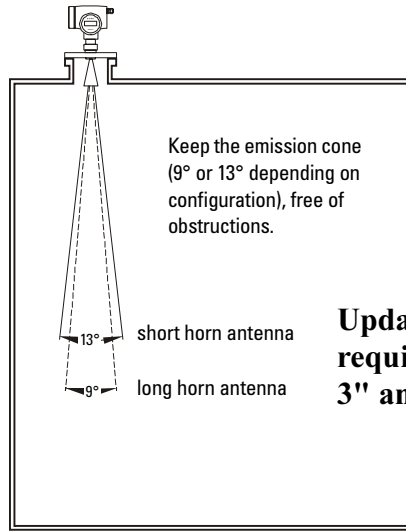

Updated graphic required showing 2", 3" and 4" horn

Correct Installation in Mounting Nozzle

The bottom edge of the antenna must project into the vessel to avoid reflective interference at the wall of the nozzle. Above flange size DN 150/6", the antenna need not project beyond the nozzle unless the radiation cone (the extension of the antenna's angle) touches the nozzle wall.

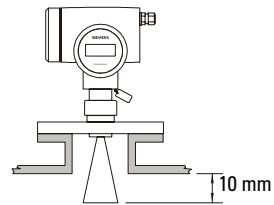

Installation using Easy Aimer LR

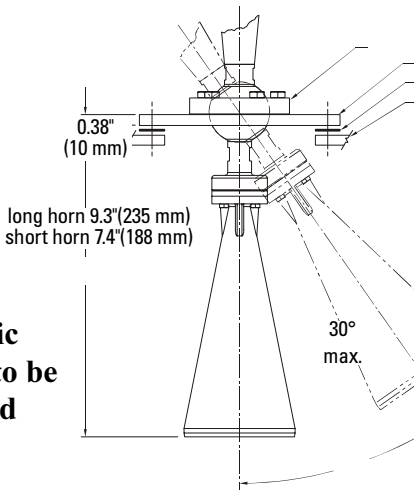

top clamping plate (upper socket)
 bottom clamping plate (lower socket)
 customer gasket [recommended thickness 1.5 to 1.8 mm (0.06 to 0.07)], as required

customer mounting plate with at least \varnothing 4" (102 mm) central opening, as required

Graphic labels to be updated

Installation

Electrical Connection

AC version:

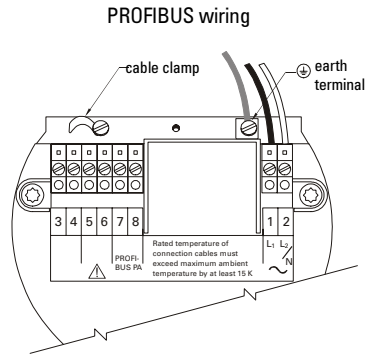
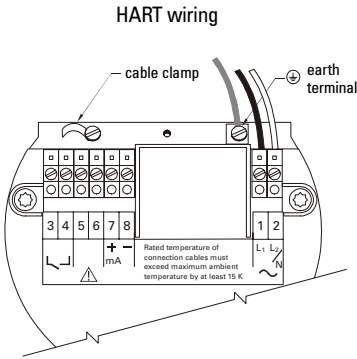

- The equipment must be protected by a 15A fuse or circuit breaker in the building installation.
- A circuit breaker or switch in the building installation, marked as the disconnect switch, shall be in close proximity to the equipment and within easy reach of the operator.



All field wiring must have insulation suitable for at least 250 V.

DC version:

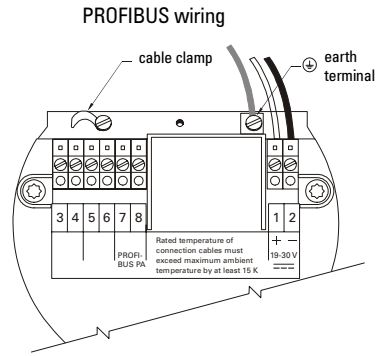
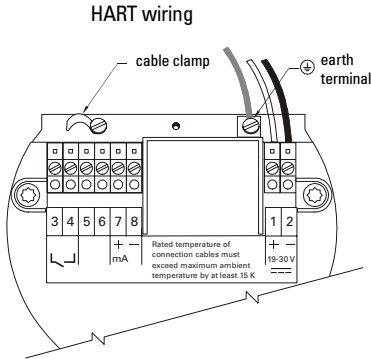

- DC input terminals shall be supplied from an SELV source in accordance with IEC 1010-1 Annex H.

Notes (AC and DC versions):

- 4-20 mA, PROFIBUS PA, DC input circuits, 14 - 20 AWG, shielded copper wire
- AC input circuit, min 14 AWG copper wire

Recommended torque on terminal clamping screws, 0.5 - 0.6 Nm.

Connecting the SITRANS LR 400:

1. Release the cover lock on the connection box with a 3 mm Allen key.
2. Unscrew the cover from the connection box.
3. Push the power cable and signal cable through the cable gland on the right of the unit, up to the terminal strip. Lay the cable in a bend before the cable gland so that moisture cannot enter the connection box.
4. Connect the earth conductor of the power supply to the earth terminal  in the connection box. Adjust the cable length so that the earth conductor will be disconnected last if you pull on the cable.
5. In devices with ignition protection types II 1/2G EEx dem [ia] IIC T6 and II 1/2G EEx dem [ib] IIC T6 or II 2G EEx dem [ia] IIC T6 and II 2G EEx dem [ib] IIC T6 (Liquids version), mount the cover for the power supply terminals.
6. Tighten the cable screw gland and check the strain relief (pull and turn).
7. In devices with ignition protection type II 1/2G EEx D IIC T6 or II 2G EEx d IIC T6 (Liquids version), replace unused screw-type cable glands with a certified dummy plug.
8. Screw the cover onto the housing and tighten it without using a tool. The sealing ring must be clean and undamaged.
9. Mount the cover lock of the connection box cover.
10. Connect the earth terminal located between the screw-type cable glands to a ground connection at your vessel by using a cable of a cross-section at least 2.5 mm².

For error-free communication via the HART protocol, a load of at least 230 Ω must be available in the signal circuit.



WARNING:

- To avoid short-circuits, do not connect a load resistance with bare wires in the connection box.
- The housing cover may not be unscrewed in a hazardous area when the device is under voltage (power supply, digital outputs on external supply).
- In devices with ignition protection types II 1/2G EEx dem [ia] IIC T6 and II 1/2G EEx dem [ib] IIC T6 or II 2G EEx dem [ia] IIC T6 and II 2G EEx dem [ib] IIC T6 (Liquids version), only the cover of the connection box may be unscrewed for test purposes. The cover on the power supply terminals may not be removed!

DRAFT

Start Up

Self-test

The device performs a self-test after power is supplied. Then, the unit is ready for programming when the multi-display appears.

Note: Frequent switching off and on of the device causes aging of the electronics (see Parameter 3.1).

Multi-display

The multi-display shows on the LCD after a successful self-test with the output of the level in the first line and the signal-to-noise ratio in the second line (factory setting):

+	1	2	.	3	0	0		m							
+	3	0		d	b										

Local Programming

When the multi-display appears on the LCD, begin local programming using the hand programmer. To access the parameter settings, press LEFT  once. Main Menu is displayed in the first line of the LCD. Then program the unit beginning with the Auto-Setup parameters.

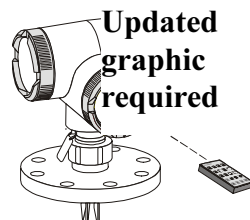

Auto-Setup

After switching on the SITRANS LR 400, and after a successful self test, press LEFT  to access the parameters. Set the Auto-Setup parameters to make the system operational: (see page 33)

- The language of the local user interface
- The unit of length of the measured level
- The nozzle height in the selected unit of length
- The vessel height in the selected unit of length
- The LRV as a distance from the bottom of the vessel
- The URV as a distance from the bottom of the vessel
- The damping of the measured level in sec
- The application type
- The bus-address by PROFIBUS PA communication (on PROFIBUS models)

Enter the necessary values as described in Parameters on page 33.

Note: It is strongly recommended that a Customer Code (Parameter 5.2) be entered after all programming is completed to secure the programmed values from changes.

If the multi-display does not appear or displays incorrect measured values after Auto-Setup, proceed as described in Troubleshooting on page 75.

Refer to the Parameter section that begins on page 32 for a list of available parameters.

Operation

General Information

You can operate the SITRANS LR 400 with:

- Hand-held infrared programmer
- HART Communicator or PROFIBUS PA
- PC/Laptop and SIMATIC PDM software (recommended)

Notes:

- The SITRANS LR 400 can be operated and programmed most comfortably with the SIMATIC PDM software. This software gives you the added possibility of saving and archiving your application-specific parameters and copying them back into the device if necessary.
- It is best to perform the operations described in the following sections directly on the device to familiarize yourself with the operation.

Measuring Principle

The SITRANS LR 400 operates according to the FMCW (Frequency Modulated Continuous Wave) method. Its antenna sends microwaves to the surface of the measuring medium. The wave frequency is modulated continuously (see Determining the Differential Frequency on page 25). A receiver registers the reflection at the surface of the measuring medium and links it with the simultaneously radiated signal.

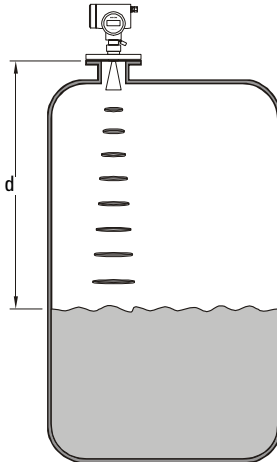

The propagation speed of microwaves in gases corresponds to the speed of light. The distance d is proportional to the propagation time t

$$d = \frac{c \cdot t}{2}$$

d = distance, t = measured time, c = speed of light

As the transmission signal has changed its frequency until the reception signal arrives, the linked signal gives a differential frequency f_d which is proportional to the distance d from the reflecting surface.

The distance d is given by the ratio of the differential frequency f_d to the frequency deviation B and the duration of a frequency modulation phase T :

$$f_d = \frac{2 \cdot B \cdot d}{T \cdot c}, d = \frac{f_d \cdot T \cdot c}{2B}$$

B = bandwidth (frequency deviation), d = distance, T = modulation duration, c = speed of light

Determining the Differential Frequency

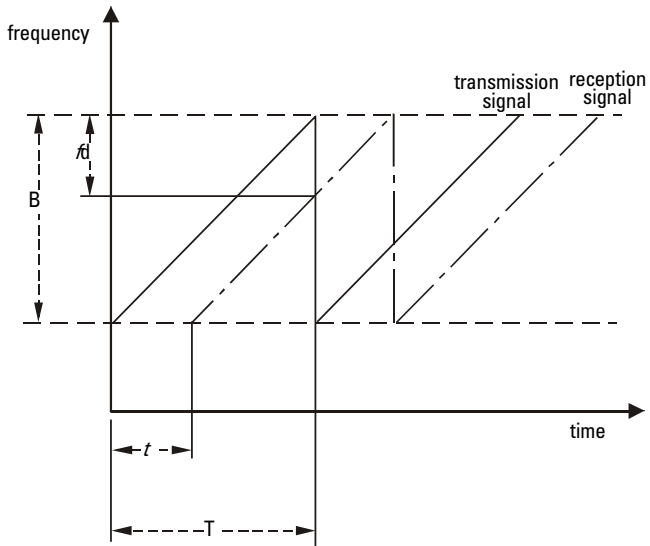

Example

The linear frequency deviation is 200 MHz at a modulation duration of 10 ms. The surface of the measuring medium is 10 m away from the transmitting antenna. The difference signal then has a frequency of:

$$f_d = \frac{2 \cdot 2 \cdot 10^8 \cdot 10}{10^{-3} \cdot 3 \cdot 10^8} = 13,333 \text{ kHz}$$

Every reflection at a surface generates a different frequency. The reception signal therefore consists of a frequency mix from which the disturbance frequencies must be filtered. These can be caused by fixed targets like struts inside the vessel.

Operating the SITRANS LR 400

Use the arrow keys at the bottom of the hand programmer to program the SITRANS LR 400. The two-line LCD displays the parameters. You can alter the setting or change to other parameters using the arrows on the hand programmer (see page 27 for information on navigating the menus using the arrow keys).

Hand Programmer

Note: The **ARROW** buttons shown below are required for programming this product. The additional buttons on the hand programmer do not apply to the SITRANS LR 400.

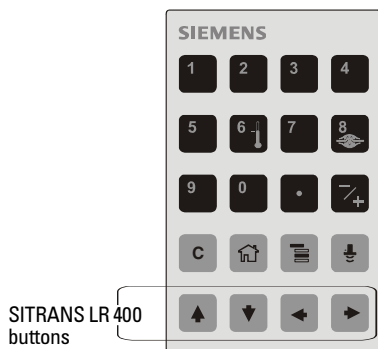

Key	Programming Mode
	Parameter scroll UP
	Parameter scroll DOWN
	LEFT Arrow (or CANCEL)
	RIGHT Arrow (or Enter)

Selecting a Parameter

After a successful self-test, the SITRANS LR 400 displays the two-line multi-display.

Press LEFT ARROW to access the parameter menus. The first line of the display tells you the current parameter menu level. The second line shows one of the parameters you can access in the current parameter group. Scroll through the parameters in the group by touching UP and DOWN . RIGHT accesses the parameter displayed on the second line. LEFT closes this parameter and moves up one level until you return to the multi-display.

When you select a parameter, its current value is displayed in the second line. When the value flashes, programming is enabled, (see Disabling and Enabling Programming on page 29) and you can change the current setting. If the parameter value cannot be changed or if programming is disabled, the value will not flash.

Note: The background illumination of the LCD switches on as soon as you use a button. It goes out about three minutes after last use of programming button.

Structure of Parameters

Operation is hierarchically structured: the parameters are arranged in groups and assigned a numerical menu identification (see example below).

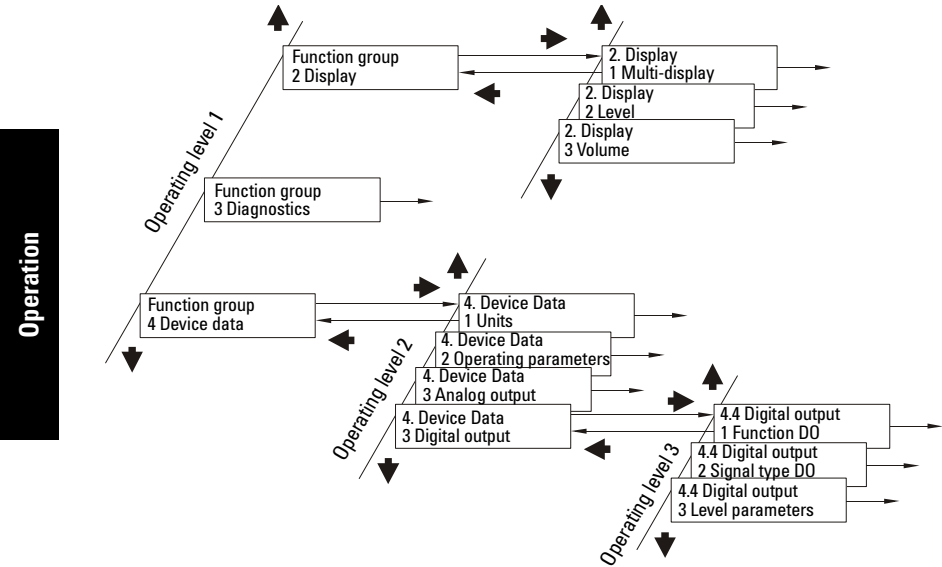





Changing a Parameter Value

Selecting a Parameter Value from a List

In many cases, you can assign a parameter a value from a list of options.

You will see a single item of the selection list in the second line of the display.







- Press UP  or DOWN  to cycle through the list and choose the desired entry. Press RIGHT  to assign the current entry to the parameter. The device accepts the new setting, closes the input and returns to the next parameter level up.
- LEFT  operates like a CANCEL key: When pressed, the device closes the parameter input but keeps the originally displayed value. It does not save a changed setting!

For an example of assigning a value from a selection list, see Operating Examples on page 30.



DRAFT

Entering a Parameter Value

The ARROW keys operate like a cursor control when entering a parameter value with the input position marked by flashing of a single character.



- Increase or decrease a character's value by using UP  and DOWN .
- Press RIGHT  to move the input position to the right. At the far right position, press RIGHT  again:  operates like an ENTER key. The device saves the changed value and closes the parameter unless the value is not within the permissible input range. Then an error message is displayed.
- Press LEFT  to move the input position to the left. At the farthest left position, press LEFT  again: it now functions as a CANCEL key. The device closes the parameter input without saving the changed value.

Top or bottom of representable range



If you press UP  when the value is at the top of the representable range, SITRANS LR 400 automatically places the value at the next highest position. If 0.9 is displayed and you press UP , the value becomes 1.0. So, 9 becomes 10, 90 or 99 become 100 (depending on whether you have set the input position to the second or first 9), etc.

This input system also works in the opposite direction: For example, when 100 is displayed and you press DOWN  on the first or second 0, the numeric value changes to 90 or 99 and the device cancels the places in front of the decimal point.

Decimal point

You can also set the cursor to the decimal point (unless an integer value is currently displayed). UP  or DOWN  then multiply or divide the displayed value by 10. The necessary additional places in front of the decimal point appear. You cannot change the number of displayed decimal places.

Display scrolling

Display text assigned to a parameter may sometimes be longer than the field of the display. An arrow pointing outward on the right or left hand side of the display line indicates that the text continues outside the display. You can move the text with RIGHT  and LEFT  by moving the pointer past the end of the line, to allow you to read the rest of the text.

See Operating Examples on page 30 for an example of manual input.

Disabling and Enabling Programming

To prevent unauthorized personnel causing programming errors through the display module, set a customer code – a personal, freely selectable code number up to 9 digits. A device protected by a customer code still displays all functions and values but it requests input of the code number before allowing a parameter to be reset.

Note: The customer code is activated 10 minutes after you have programmed Parameter 5.2 Customer Code.

Programming is enabled when you:

- enter the requested customer code for the current parameter. (Only the current parameter is enabled for reprogramming. All the others are still waiting for input of the customer code.)
or
- release the programming lock for all parameters at once using the Code Input Parameter (see Parameter 5.1 on page 62).

The programming lock will be released for approximately 10 minutes.

When you return to the multi-display or enter a number in the Code Input parameter which is different from the customer code, or do not operate the device for 10 minutes, the programming lock is enabled.

Note: If Customer Code (Parameter 5.2) is 0, programming of parameters is always enabled. We strongly recommend that a customer code be entered after all programming is completed to secure the programmed values from change.

Operating Examples

Example 1(HART)

The length unit should be changed from m to mm. The starting point is the multi-display.

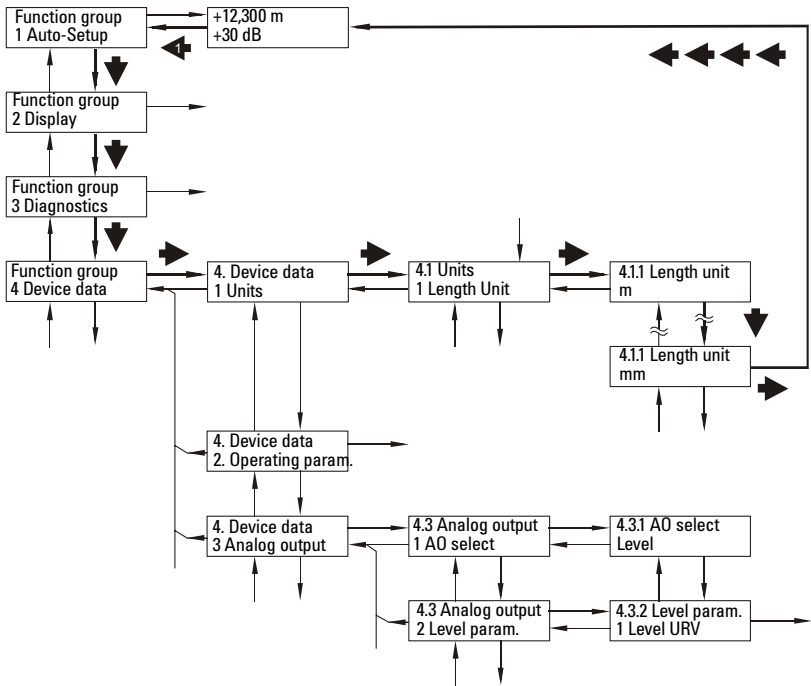

Follow the bold path in the diagram above for input. The other paths lead to other device functions and parameters which are not required in this example. Use the arrow buttons shown next to the numbered operating steps.

DRAFT

Example 2

The filling speed should be changed from 2.0 cm/min to 100 cm/min.

Access the Fill speed parameter from the multi-display according to instructions on page 27.

The default setting appears in the display.

4.	2.	2.	5.	f	i	l	l	i	n	g	s	p	e	e
+	2.	0	0	c	m	/	m	i	n					

Enable the programming.
The second segment of the second display line flashes.

4.	2.	2.	5.	f	i	l	l	i	n	g	s	p	e	e
+	2.	,	0	0	c	m	/	m	i	n				

Set the digit to 1 with DOWN  arrow.

4.	2.	2.	5.	f	i	l	l	i	n	g	s	p	e	e
+	1.	,	0	0	c	m	/	m	i	n				

Select the decimal point with RIGHT  arrow.

4.	2.	2.	5.	f	i	l	l	i	n	g	s	p	e	e
+	1.	,	0	0	c	m	/	m	i	n				

Press UP  arrow twice so that two other places appear in front of the decimal point.

4.	2.	2.	5.	f	i	l	l	i	n	g	s	p	e	e
+	1	0	0	,	0	0	c	m	/	m	i	n		

Select the last decimal place with RIGHT  arrow.

4.	2.	2.	5.	f	i	l	l	i	n	g	s	p	e	e
+	1	0	0	,	0	0	c	m	/	m	i	n		

And end the input with RIGHT  arrow (ENTER function).

4.	2.	2.	M	e	a	s	u	r	.	c	o	n	d	i	t
5	f	i	l	l	i	n	g	s	p	e	e	d			

Parameters (HART)

The parameter groups are followed by the parameters within each group. The parameter tables show the values you need to enter and are followed by additional information when necessary. Factory settings are displayed after the parameter name, where applicable.

Note: Parameter menus are dependent on selections made by the user. In some cases, parameter menus are renumbered according to the selection made at the previous menu level. See table below for an example.

When User chooses Parameter 4.2.2.1: Application Type = Liquids (Process)	When User chooses Parameter 4.2.2.1: Application Type = User tank1
4.2.2.2: Surface	(not available when 4.2.2.1 = User tank1)
4.2.2.3: Deadband	4.2.2.2: Deadband
4.2.2.4: Correction Factor	4.2.2.3: Correction Factor
4.2.2.5: Filling Speed	(not available when 4.2.2.1 = User tank1)
4.2.2.6: Reflectivity	(not available when 4.2.2.1 = User tank1)
4.2.2.7: Failsafe Level	4.2.2.4: Failsafe Level
4.2.2.8: Failsafe Timer	4.2.2.5: Failsafe Timer
4.2.2.9: Range Extension	4.2.2.6: Range Extension

Functional Dimensions

- 1. Nozzle height
- 2. Dead band
- 3. Raw value (measured)
- 4. Level (=calculated value)
- 5. Lower range value
- 6. Lower limit
- 7. Upper limit
- 8. Upper range value
- 9. Vessel height

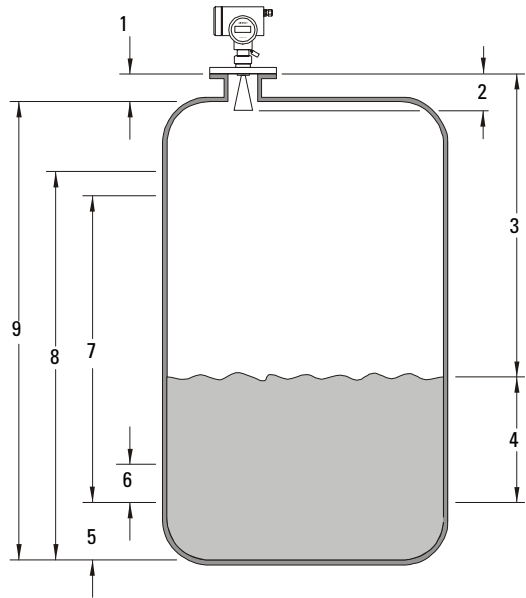

Required Parameters

Note: The following parameters are absolutely essential for proper operation of the device. They apply to all applications and are required to make the system operational.

1. Auto-Setup

1.1: Language Local (F = English)

Language of the local user interface

Value	English
	Deutsch

DRAFT

1.2: Length Unit (F = m)

Units of measurement

Value	cm
	m
	mm
	ft
	in

1.3: Nozzle Height (F = 0 m)

Length of nozzle from top of flange to top of vessel (see Functional Dimensions on page 33)

Value	numerical value
-------	-----------------

1.4: Tank Height (F = 20 m)

Height of vessel from bottom of nozzle to bottom of vessel (see Functional Dimensions on page 33)

Value	numerical value
-------	-----------------

1.5: Level URV (F = 20 m)

Full scale of level (see Functional Dimensions on page 33)

Value	numerical value
-------	-----------------

Set the URV as the level above the bottom of the vessel (see Functional Dimensions on page 33) in the units system selected with Function 4.1.1. It corresponds to an output current of 20 mA.

1.6: Level LRV (F = 0 m)

Empty scale of level (see Functional Dimensions on page 33)

Value	numerical value
-------	-----------------

Set the LRV as the level above the bottom of the vessel (see Functional Dimensions on page 33) in the units system selected with Function 4.1.1. It corresponds to an output current of 4 mA.

1.7: Level damping (F = 1 s)

Damping of level in s

Value	numerical value
-------	-----------------

Set the damping of the level value in seconds. It acts on the analog output, the limit value monitor and the local display. For damping of the sensor signal, set Parameter 4.2.3.1. For slow moving solids applications, use a value of 500.

1.8: Application Type (F - Liquid [process])

Use of the vessel

Value	Liquid (store)[Liquid]
	Liquid (process)[Liquid]
	Silo1 (solids)
	Silo2 (solids)
	User tank1
	User tank2

Select Silo1 (solids) for tall, narrow silos. Select Silo 2 (solids) for large diameter silos, typically used for cement. In most cases, you set one of the pre-specified applications. The user vessels may adopt configurations which deviate from the factory settings. These are designed for special applications loaded at the factory or by service personnel.

Note: The following parameters cannot be accessed when you set a user vessel: Parameter 4.2.2.2 (Surface), Parameter 4.2.2.5 (Filling Speed), Parameter 4.2.2.6 (Reflectivity), and Sensor Parameters 4.2.3.1 (Sensor Damping), 4.2.3.2 (Multiple Echoes), 4.2.3.3 (Echo Motion), 4.2.3.4 (Window Tracking), and 4.2.3.5 (Tank Empty Detect). However, the parameters that remain under 4.2.2.x will be renumbered. See page 32 for more information on parameter renumbering.

Additional Parameters

2. Display

2.1: Multi-display (F = level in m Signal to noise ratio in db)

Display of two measured values. Values are determined in Parameter 4.5.1.1 (Line 1 Local) and in Parameter 4.5.1.4 (Line 2 Local).

2.2: Level (F = m)

Current level of measured medium (set unit using Length Unit in Auto-Setup)

2.3: Volume ($F = m^3$)

Volume of measured medium (set unit using Parameter 4.1.2 [Volume Unit])

2.4: Mass (for qualified personnel only)

This parameter is for Factory Authorized Personnel Only.

2.5: Current Output

Value of the analog output in mA

When the device electronics are working properly, the displayed current value will correspond to the measured output current.

2.6: Digital Output

State of digital output

3. Diagnostics

3.1: Status

Here you can access current status messages of the device. Parameter 3.1.1 is always accessible; other parameters (Parameter 3.1.x) appear in the appropriate order if they contain error messages.

3.1.1: Wear

3.1.1.1: Operating Hours

Total previous operating time of the device in hours (approximate value)

3.1.1.2: Maximum Temperature ($F = 26\text{ }^{\circ}\text{C}$)

Previous maximum internal temperature of the device

Note: This temperature must not exceed $85\text{ }^{\circ}\text{C}$ ($185\text{ }^{\circ}\text{F}$) or warranty may be void.

3.1.1.3: Minimum Temperature ($F = 26\text{ }^{\circ}\text{C}$)

Previous minimum internal temperature of the device

3.1.1.4: Aging

Approximate value for the previous life of the device in % ($100\% = \text{approx. } 10\text{ years}$)

This parameter outputs a calculated percentage which estimates the wear of the device due to aging.

3.1.1.5: Hours > 85 °C

Total time the maximum permissible internal temperature was exceeded, in hours

3.1.x: Sensor, electronics, software, application, parameters, service

These parameters are only displayed if they contain an error message. The number of the menu items matches the number of defective functions and can range in extreme cases from 3.1.2 to 3.1.7.

See Troubleshooting on page 75 for the individual error messages and possible remedies.

3.1.x: Sensor

Diagnostic messages of the sensor

and/or

3.1.x: Electronics

Diagnostic messages of the electronics

and/or

3.1.x: Software

Diagnostic messages of the software

and/or

DRAFT

3.1.x: Application

Diagnostic messages to the application

and/or

3.1.x: Parameters

Display of the false parameters

and/or

3.1.x: Service

For service purposes only

3.2: Device Test

3.2.1: Self-test

Check device state

The device integrates the self-test routines in the ongoing measurements; it completes them after approximately 10 seconds. It confirms a successful self-test with the display . The display signals an error. Read out the error type according to Parameter 3.1.x.

3.2.2: Display test

Visual check of LCD

During the test of the LCD, the display first goes blank for 5 seconds and then lights up for another 5 seconds so that you can determine whether individual display points have failed.

3.3: Simulation

This parameter can support testing the correct functions of the connections during commissioning or maintenance of the device. With the two sub-parameters, you can temporarily replace the measured values at the analog and digital output with known simulated output values.

Note: The Simulation parameter influences output to the control system.

3.3.1: Simulate A0 (F = 4 mA)

Simulation of the analog output signal

Value	4 mA
	10 mA
	12 mA
	20 mA
	Error signal

When this parameter is accessed and a value is entered, the device sets the defined current value that can be validated.

Complete the parameter function by pressing LEFT so the analog output again gives the measured value.

3.3.2: Simulate DO (F = End)

Simulation of the digital output signal

Value	Relay on
	Relay off
	End

Select the applied output value (relay on or relay off).

The parameter function is completed by pressing LEFT  so that the digital output again gives an alarm/limit.

3.4: Sensor Variables

You can read out device-internal data with this parameter group. The displayed values depend on the respective application. You can access the following data:

3.4.1: Raw Value (for service purposes only)

Distance from the flange to measuring medium

The measured distance from the flange to the surface of the measuring medium.

3.4.2: Echo Amplitude

Measure of quality of reflection

This dimensionless value is an absolute measure of the strength of reflection at the measuring medium. Its display can be evaluated as follows:

- $x > 1$: very good
- $1 > x > 0.5$: good
- $0.5 > x > 0.05$: satisfactory
- $x < 0.05$: uncertain

3.4.3: S/N Ratio

Signal-to-noise ratio of the measured value in dB

S/N ratio provides a relative measure of the strength of reflection of the measuring medium in dB. Its display can be evaluated as follows:

- $x > 20$: very good
- $20 > x > 10$: good
- $x < 10$: satisfactory

3.4.4: Validity

Validity of the measured value in %

This parameter provides a percentage measure of the certainty that the displayed measured value corresponds to the real level and does not represent a multiple echo or a fixed target. Its display can be evaluated as follows:

- $x > 70$: very good
- $70 > x > 50$: good
- $50 > x > 20$: uncertain
- $x < 20$: no plausible measured value

3.4.5: Sensor Temp

Sensor temperature

4. Device Data

4.1: Units

4.1.1: Length Unit = Parameter 1.2

4.1.2: Volume unit ($F = m^3$)

Value	bbl
	yd ³
	ft ³
	in ³
	bush
	bbl (liq)
	l
	m ³
	hL
	Gal
	ImpGal

4.1.3: Mass Unit (for qualified personnel only)

This parameter is for Factory Authorized Personnel Only.

4.1.4: Temperature Unit (F = °C)

Unit of the sensor temperature

Value	°C
	°F
	K

4.1.5: Other units (F = SI)

Units system for all other units

Value	SI unit
	US/UK unit

With this function, determine whether you want to enter the operating parameters (see Parameter 4.2) in SI or in British Imperial (US/UK) units. The selected units of the measured value output and sensor temperature as well as the decimal point are not influenced by this setting.

4.2: Operating Parameters

With this parameter group, define the parameters of your vessel, the measuring medium and the calculation of the measured signal. Signal-specific default settings such as the failure signal or the upper current limit of the analog output signal are assigned to the functions of the respective outputs (see Parameters 4.3 and 4.4).

4.2.1: Tank Geometry

4.2.1.1: Nozzle Height = Parameter 1.3

4.2.1.2: Tank Height = Parameter 1.4

4.2.1.3: Stilling Pipe? (F = no) [Liquids]

Stilling pipe available?

Value	Yes
	No

By selecting yes or no, you specify whether the device is mounted on a stilling pipe. If you select yes, Parameter 4.2.1.3.2 is enabled so you can specify the internal diameter of the stilling pipe.

4.2.1.3.2: Pipe Diameter (F = 100 mm) [Liquids]

Internal diameter of the stilling pipe

Value	numerical value
-------	-----------------

4.2.2: Measuring Conditions

4.2.2.1: Application Type (F - Liquid [process])

Use of the vessel

Value	Liquid (store) [Liquids]
	Liquid (process) [Liquids]
	Silo1 (solids)
	Silo2 (solids)
	User tank1
	User tank2

Select Silo1 (solids) for tall, narrow silos. Select Silo 2 (solids) for large diameter silos typically used for cement. In most cases you set one of the pre-specified applications here. The user vessels may adopt configurations which deviate from the factory settings. These are designed for special applications loaded at the factory or by service.

Note: The following parameters cannot be accessed when you set a user vessel: Parameter 4.2.2.2 (Surface), Parameter 4.2.2.5 (Filling Speed), Parameter 4.2.2.6 (Reflectivity), and Sensor Parameters 4.2.3.1 (Sensor Damping), 4.2.3.2 (Multiple Echoes), 4.2.3.3 (Echo Motion), 4.2.3.4 (Window Tracking), and 4.2.3.5 (Tank Empty Detect). However, the parameters that remain under 4.2.2.x will be renumbered. See page 32 for more information on parameter renumbering.

4.2.2.2: Surface (F = wavy)

Surface structure of the measuring medium. Not displayed if a user vessel is selected in Parameter 4.2.2.1.

Value	Smooth
	Wavy
	Turbulent

This parameter is not displayed when a user vessel is selected in Parameter 4.2.2.1. When used with poorly reflecting measuring media, you may be able to improve measuring results by setting a different surface structure here. If your measuring medium forms waves more than 1 cm in height, you should select the wavy setting. The turbulent setting is recommended for waves greater than 10 cm.

4.2.2.3: Dead band (F = 0.4 m)

Area below the flange in which measured values are ignored

Value	numerical value, Minimum value = Length of the antenna
-------	--

Specification of a dead band in the units system selected according to Parameter 4.1.5 defines a minimum distance from the flange which the measuring medium must have for the device to accept the measured values as valid. This suppresses reflective interference generated by the nozzle, close obstacles, or the antenna. For solids applications, a dead band setting of 1 m minimum is recommended

Note: The dead band should exceed the antenna's length.

4.2.2.4: Correction Factor (F = 1.0)

Correction factor for physical measuring influences

Value	numerical value
-------	-----------------

The propagation time of the microwaves between the antenna and the measuring medium changes slightly depending on the pressure inside the vessel. If this pressure is constant, however, it can be included in the evaluation according to the equation:

$$K = \frac{1}{\sqrt{1 + (\epsilon_{r, Gas} - 1) \cdot \frac{273 \cdot p}{T_{Gas} + 273}}}$$

K = correction factor, p = pressure inside the vessel in bar, T_{gas} = gas temperature in °C, $\epsilon_{r, Gas}$ = dielectric of the overlying gas, e.g. $\epsilon_{p, air} = 1.00059$

Enter the correction factor K as a dimensionless value.

4.2.2.5: Filling Speed (F = 200 mm/min)

Typical speed of change of the level. Not displayed if user vessel is selected in Parameter 4.2.2.1 (Application Type).

Value	numerical value
-------	-----------------

This parameter is not displayed when a user vessel is selected in Parameter 4.2.2.1. When you determine that the displayed measured value does not follow the change in the height of the level in the vessel, you can enter a value for the speed with which it generally changes. This assigns a greater probability to measuring targets which move at this speed.

If the display does not follow the level height continuously but in abrupt jumps, you should choose a higher filling speed. If multiple echoes are indicated during filling/emptying a vessel, select a lower filling speed. In the case of very low filling speeds (a few mm/min) switch off Parameter 4.2.3.3. If different filling/emptying speeds occur, select the higher speed.

4.2.2.6: Reflectivity (for qualified personnel only)

This parameter is for Factory Authorized Personnel Only.

4.2.2.7: Failsafe Level (F = Hold Continuously)

Selects the default measurement in the event that the failsafe timer expires

Value	100 %
	0 %
	Hold Continuously

4.2.2.8: Failsafe Timer (F = 10 min)

Sets the time delay, in minutes, before entering failsafe level

Value	1 min
	2 min, etc.

The failsafe timer begins when there is a loss of echo condition. This loss of echo condition will occur when there is no signal available above the Auto False Echo Suppression threshold as defined in Parameter 4.2.3.9.

4.2.2.9: Range Extension (F = 3 m)

Sets the amount of range extension as measured from the tank height and extending beyond the measurement range. For vessels with conical or parabolic bottoms, you may need to increase this value to ensure an empty vessel reads empty.

Value	numerical
-------	-----------

4.2.3: Sensor Parameter

Here you can view and change the sensor parameters which you have selected according to Parameter 4.2.2 (Measuring Conditions).

Note: The factory settings for the user vessels are not editable.

4.2.3.1: Sensor Damping (F = 1 s)

Averaging of measuring signal. Not displayed if a user vessel is selected in Parameter 4.2.2.1 (Application Type).

Value	numerical
-------	-----------

Enter the damping in seconds.

This parameter is not displayed when a user vessel is selected in Parameter 4.2.2.1 (Application Type). The sensor damping influences the evaluation of the measuring signal. If the level generally only changes slowly and continuously, a time constant set here can improve the measuring accuracy and the validity in poorly reflecting measuring media or those with a restless surface. The sensor damping must always be smaller than the interval of the time of change of the level (e.g. 1 mm/10 s), because too high a value would have a negative influence on the measuring result.

Note: Specification of damping directly influences the evaluation of the measuring signal. If you only want to dampen the calculated outputs at the analog output, you should set the damping of level, volume or mass described in Function 4.2.4.4 (MinLim Level).

4.2.3.2: Multiple Echo (F = on)

Evaluate multiple echo

Value	On
	Off

The multiple echo evaluation suppresses multiple reflections by assigning them a lower probability than the measuring signal.

4.2.3.3: Echo Motion (F = off)

Evaluate echo motion

Value	On
	Off

Dynamic processes in the vessel are included in the evaluation of the measuring targets. The typical filling speed can be set in Parameter 4.2.2.5. If the measured value still does not follow the level height, switching off echo motion may improve the result.

4.2.3.4: Window Tracking (F = Off)

Value	On
	Off

A window follows the measured value which it is forced to track. The window size is calculated from the set filling speed. Switch off window tracking for applications where the SITRANS LR 400 is unable to keep up to level changes. By using SIMATIC PDM, you can display a list of all echoes in your vessel. It provides the distance between the flange and the measuring medium's surface, as well as the distances of fixed targets. These may be directly used and transferred to the fix distance list.

4.2.3.5: Tank Empty Detect (for qualified personnel only)

This parameter is for Factory Authorized Personnel Only.

4.2.3.6: Auto Fix Distance (for qualified personnel only)

This parameter is for Factory Authorized Personnel Only.

4.2.3.7: Fix Distance List (for qualified personnel only)

This parameter is for Factory Authorized Personnel Only.

4.2.3.7.1 to 4.2.3.7.9: Fix Distance Values (for qualified personnel only)

These parameters are for Factory Authorized Personnel Only

4.2.3.8: Auto False Echo Suppression (F = Use)

Learns and records the current signal up to the suppression distance setting. These signals are then ignored during operation.

Note: This function works best when the vessel is nearly empty. For best results, do not record or learn when the vessel is completely empty.

Value	Off
	Record
	Use

If all signals fall below this defined threshold, then the failsafe timer is initiated.

DRAFT

4.2.3.9: Auto False Echo Suppression Distance (F = 2/3 tank height)

Defines the end point of the auto false echo suppression distance

Value	variable
-------	----------

4.2.3.A: Hover Level (F = 40%)

Defines (in percent) how high the TVT (Time Varying Threshold) curve is placed above the profile, relative to the largest echo. When SITRANS LR 400 is located in the center of the vessel, lower this parameter to prevent multiple echo detections.

Values	Range: 0 to 100%
--------	------------------

4.2.3.B: Window Trigger (F = 80%)

Defines the position of the window on the leading edge of the selected echo, relative to the amplitude. Used only on Silo1 and Silo2 applications (see Application Type on page 35).

Values	Range: 0 to 100%
--------	------------------

4.2.4: Level Parameter

4.2.4.1: Level URV (F = 20 m)

Full scale of level (see Functional Dimensions on page 33)

Value	numerical value
-------	-----------------

Set the URV as the level above the bottom of the vessel (see Functional Dimensions on page 33) in the units system selected with Parameter 4.1.1. It corresponds to an output current of 20 mA.

Note: This parameter is also set using Parameter 1.5 (Level URV).

4.2.4.2: Level LRV (F = 0 m)

Empty scale of level (see Functional Dimensions on page 33)

Value	numerical value
-------	-----------------

Set the LRV as the level above the bottom of the vessel (see Functional Dimensions on page 33) in the units system selected with Parameter 4.1.1. It corresponds to an output current of 4 mA.

Note: This parameter is also set using Parameter 1.6 (Level LRV).

4.2.4.3: Level damping (F = 1 s)

Damping of level in s

Value	numerical value
-------	-----------------

Set the damping of the level value in seconds. It acts on the analog output, the limit value monitor and the local display. For damping of the sensor signal, set Parameter 4.2.3.1.

Note: This parameter is also set using Parameter 1.7 (Level Damping).

4.2.4.4: MinLim Level (F = 0 m)

Lower limit value of the level (see Functional Dimensions on page 33)

Value	numerical value
-------	-----------------

Set the lower limit value of the level as a height above the LRV.

4.2.4.5: MaxLim Level (F = 20 m)

Upper limit value of the level (see Functional Dimensions on page 33)

Value	numerical value
-------	-----------------

Set the upper limit value of the level as a height above the LRV.

4.2.4.6: HYST Level (F = 0.5 m)

Hysteresis of the level limit values

Value	numerical value
-------	-----------------

Set the hysteresis of the limit values in the units system selected according to Parameter 4.1.1 (see diagram below).

Limit value alarm

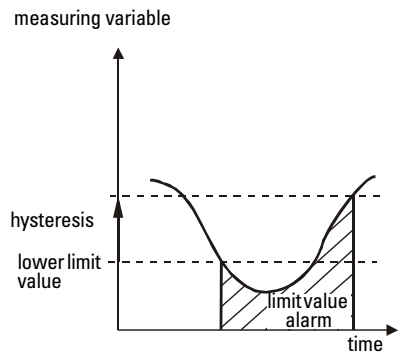
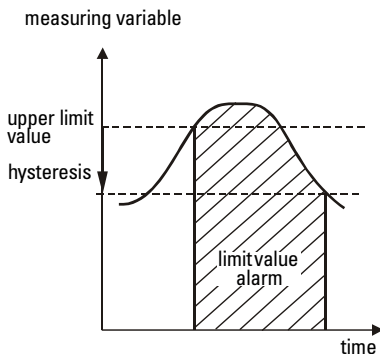

4.2.5: Volume Parameters

To calculate the volume of the measuring medium, you need the level parameters (Parameter 4.2.4) in the units selected according to Parameter 4.1.1 and additionally a tank characteristic (Parameter 4.2.5.7).

4.2.5.1: Volume URV (F = 20 m³)

Full scale of volume

Value	numerical value
-------	-----------------

4.2.5.2: Volume LRV (F = 0 m³)

Start of scale of volume

Value	numerical value
-------	-----------------

4.2.5.3: Volume Damping (F = 1 s)

Damping of volume

Value	numerical value
-------	-----------------

4.2.5.4: MinLim Volume (F = 0 m³)

Lower limit value of volume

Value	numerical value
-------	-----------------

4.2.5.5: MaxLim Volume (F = 20 m³)

Upper limit value of volume

Value	numerical value
-------	-----------------

4.2.5.6: HYST Volume (F = 0.5 m³)

Hysteresis of the volume limit values

Value	numerical value
-------	-----------------

4.2.5.7: Tank Characteristic (F = Calculate)

Determining the vessel characteristic

Value	Calibrate/table
	Calculate

Note: Select the option Calibrate/table or Calculate as required. The selection controls the display of Parameter 4.2.5.8. The possibilities of each parameter are listed below. For the values associated with Parameter 4.2.5.8: Calculate, go to page 51.

4.2.5.8: Calibrate/table

If your vessel deviates from the forms offered, the necessary data is not available or is unknown, or you need a vessel characteristic with greater accuracy, you will need to use a level/volume calibration table. You can enter reference values from a table provided by the vessel manufacturer or do the calibration manually and enter the determined reference values.



You can only enter pairs of values consisting of level and volume.

Note: Entering the vessel characteristic with the hand programmer can be a time-consuming procedure. It can be done more quickly and comfortably with the SIMATIC PDM software. There, an entered table can be edited simply – an option which is only conditionally possible with the hand programmer.

The 4.2.5.8 Calibrate/table parameter offers the following selection possibilities:

4.2.5.8.1: Calibrate

Here you can enter up to 50 reference values whose levels SITRANS LR 400 measures. Enter the appropriate volume (determined by manual calibration).

If you access this parameter, first the currently measured level is displayed. Accept it by pressing LEFT . Enter the appropriate volume: save it by pressing RIGHT  or reject it by pressing LEFT .

Then the device displays Calibrate. Access again by pressing RIGHT  to select a further reference value. The device automatically offers you the next undefined reference value.

We recommend entering a maximum of two or three reference values for the linear range of the vessel and to use the others for the non-linear portion.

If you enter a second volume value for the same level, the reference value saved earlier is overwritten.

4.2.5.8.2: Enter table

Manual entry of a table

Value	numerical value
-------	-----------------

Here you can enter up to 50 reference values provided by the vessel manufacturer in any order.

The first reference value is offered when you access the parameter. Enter the level as a distance from the floor of the vessel in the units selected according to Parameter 4.1.1 (Enter level) and the volume corresponding to the level (Enter volume).

The device then displays Enter table again. Access again to enter a further reference value. The device automatically offers you the next undefined reference value.

We recommend entering a maximum of two or three reference values for the linear range of the vessel. Use the other reference values for the non-linear section.

If you enter a second volume value for the same level, the reference value saved earlier is overwritten.

4.2.5.8.3: Show table

Display table

Value	selection
-------	-----------

Here you can display the entered reference values sorted on levels. In the second line, the level corresponding to the first reference value appears first and then the corresponding volume value when you switch further. Each switching accesses a further reference value.

4.2.5.8.4: Clear table

Delete table

Value	selection
-------	-----------

If you choose *all* in this parameter, the entire saved table is deleted. You can delete individual reference values with the selection 1st, 2nd etc. that were displayed in Parameter 4.2.5.8.3.

Note: The reference values are sorted in order of filling states and do not necessarily correspond to the order of the value pairs you have entered.

or

4.2.5.8: Calculate

Automatic calculation of a vessel characteristic is faster than manual entry by calibrating or a table. However, the calculated vessel characteristic is not as accurate as a manually calibrated characteristic – especially in the non-linear sections of the vessel when errors of $\leq 1\%$ may occur. As well, the necessary data which you can get from the design documents of your vessel must still correspond to the real conditions.

The 4.2.5.8: Calculate parameter requires the following parameters:

4.2.5.8.1: Tank Design (F = Vertical Cylinder)

Value	Linear
	Vertical cylinder
	Horizontal cylinder
	Sphere

Enter the external form of your vessel. You can choose from:

- Linear (any form with vertical walls and a flat floor)
- Vertical cylinder (vertically standing cylindrical form with curved covers)
- Horizontal cylinder (horizontal cylindrical form with curved caps)
- Sphere

4.2.5.8.2: Bottom Design (F = Dished end)

Value	Dished end
	Basket end
	Bullet bottom

Enter the form of the two vessel cover caps. You can choose from:

- Dished (according to DIN 28011)
- Basket (according to DIN 28013)
- Bullet (hemispherical shaped floor)

4.2.5.8.3: Tank volume (F = 20 m³)

Value	numerical value
-------	-----------------

4.2.5.8.4: Tank height (F = 20 m)

Value	numerical value
-------	-----------------

4.2.6: Mass Parameters (for qualified personnel only)

Mass parameters 4.2.6.1 to 4.2.6.9 are for Factory Authorized Personnel Only.

4.2.6.1: Mass URV (for qualified personnel only)

4.2.6.2: Mass LRV (for qualified personnel only)

4.2.6.3: Mass Damping (for qualified personnel only)

4.2.6.4: MinLim Mass (for qualified personnel only)

4.2.6.5: MaxLim Mass (for qualified personnel only)

4.2.6.6: HYST Mass (for qualified personnel only)

4.2.6.7 Tank Characteristic (for qualified personnel only)

4.2.6.8 Calibrate/table or Calculate (for qualified personnel only)

Note: The value of Parameter 4.2.6.8 is determined by the selection (Calibrate/table or Calculate) in Parameter 4.2.6.7.

4.2.6.8 Calibrate/table

4.2.6.8.1: Calibrate (for qualified personnel only)

4.2.6.8.2: Enter table (for qualified personnel only)

4.2.6.8.3: Show table (for qualified personnel only)

4.2.6.8.4: Clear table (for qualified personnel only)

or

4.2.6.8 Calculate

4.2.6.8.1: Tank design (for qualified personnel only)

4.2.6.8.2: Bottom design (for qualified personnel only)

4.2.6.8.3: Tank volume (for qualified personnel only)

4.2.6.8.4: Tank height (for qualified personnel only)

4.2.6.9: Density (for qualified personnel only)

4.2.7.x: User1 Parameters (for qualified personnel only)

All parameters in range 4.2.7.x are for Factory Authorized Personnel Only. Advanced echo processing parameters should only be modified by qualified personnel.

4.2.8.x: User2 Parameters (for qualified personnel only)

All parameters in range 4.2.8.x are for Factory Authorized Personnel Only. Advanced echo processing parameters should only be modified by qualified personnel.

DRAFT

4.3: Analog Output

4.3.1: Error Level (F = D: Error Signal)

Level for the error signal to alarm in Analog or Digital output

Value	D: Error Signal
	D+F: Error Signal
	D+F+W: Error Signal

When D is selected, all errors are displayed. When D+F is selected, there is special handling for failsafe. When D+F+W is selected, there is special handling for warnings.

4.3.2: AO Select (F = Level)

Assignment of a measured value to the analog output

Value	Level
	Volume
	Mass

Here you can set whether the analog output supplies the level, volume, or mass to the control system.

Note: The value of Parameter 4.3.3 is determined by the selection (Level, Volume or Mass) in Parameter 4.3.2 (AO select).

If 4.3.2 (AO Select) = Level

4.3.3: Level Parameter (= Parameter 4.2.4)

If 4.3.2 (AO Select) = Volume

4.3.3: Volume Parameter (= Parameter 4.2.5)

If 4.3.2 (AO Select) = Mass

4.3.3: Mass Parameter (= Parameter 4.2.6)

4.3.4: Current Limit (F = 20 mA)

Upper current limit

Value	20 - 22.5 mA
-------	--------------

Here you can set the upper current limit of the output signal in steps of 0.1 mA (see Current limiting diagram on next page).

Current limiting

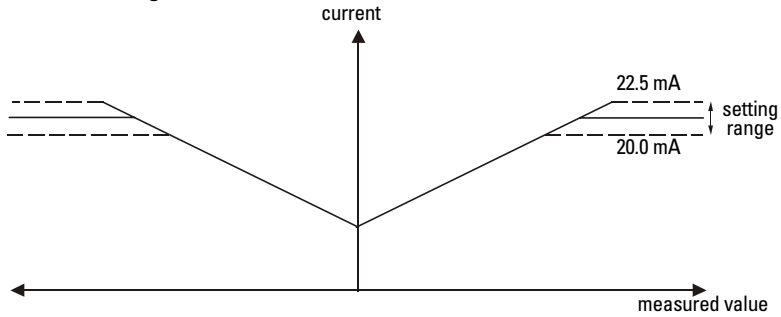

The URV is always at 20 mA. If you set the current limit to a higher value, you can have the measured values output outside the measuring range (up to approx. 115%).

4.3.5: Error Signal (F = 3.6 mA)

Current value of the error signal

Value	3.6 mA
	22.0 mA
	24.0 mA
	Hold 10 s
	Hold 1 min
	Hold 2 min
	Hold 3 min
	Hold continuously

In the event of a fault the device applies the current defined here to the analog output. You can choose between 3.6 mA, 22 mA, 24 mA, Hold 10 s, Hold 1 min, Hold 2 min, Hold 3 min and Hold continuously.

When the Hold... values are selected, the device outputs the last valid value until the set time has run out or the fault has been eliminated. If the fault persists after the set time runs out, the analog output switches to an error signal of 3.6 mA.

Note: A fault is different from a loss of echo which indicates a failsafe condition.

DRAFT

4.4 Digital Output

4.4.1: Function DO (F = Alarm)

Assignment of the digital output

Value	MaxLim level
	MinLim level
	MaxLim volume
	MinLim volume
	MaxLim mass
	MinLim mass
	Alarm
	No function

Here you can select whether the digital output supplies the upper or lower limit value of level or volume or an alarm (device error, measurement error; see Parameter 3.1) to the control system. If you select the **No function** option, the digital output is switched off.

Selection of a limit value enables Parameter 4.4.4. If you select Alarm or No function in this parameter, Parameter 4.4.4 will not be visible.

Note: The value of Parameter 4.4.4 is determined by the MaxLim or MinLim selection chosen in 4.4.1 (Function DO).

4.4.2: Error Level (F = D: Error Signal)

Level for the error signal to alarm in Analog or Digital output

Value	D: Error signal
	D+F: Error signal
	D+F+W: Error signal

When D is selected, all errors are displayed. When D+F is selected, there is special handling for failsafe. When D+F+W is selected, there is special handling for warnings.

4.4.3: Signal Type DO (F = Relay closes)

Value	Relay closes
	Relay opens

Here you can determine the behavior of the digital output. Select whether its contact closes or opens at an event.

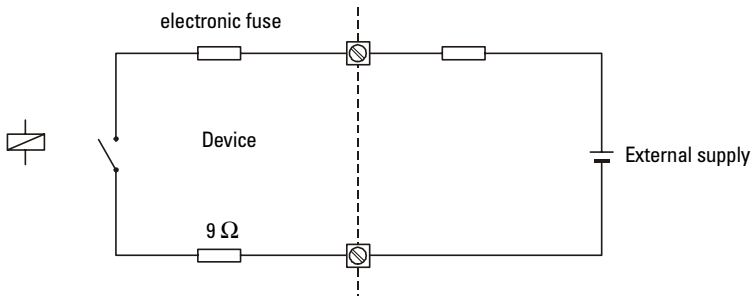

If 4.4.1 (Function DO) = MaxLim level or MinLim level

4.4.4: Level Parameter (= Parameter 4.2.4)

If 4.4.1 (Function DO) = MaxLim volume or MinLim volume

4.4.4: Volume Parameter (= Parameter 4.2.5)

If 4.4.1 (Function DO) = MaxLim mass or MinLim mass

4.4.4: Mass Parameter (= Parameter 4.2.6)

4.5: Display Parameters

4.5.1: Multi-Display

4.5.1.1: Line 1 Local (F = Level)

Choice of measured value in line 1

Value	Level
	Volume
	Mass

Note: The value of 4.5.1.3 is determined by the selection (Level, Volume or Mass) in Parameter 4.5.1.1 (Line 1 Local).

4.5.1.2: Display Local (F = Eng Unit)

Method of display in line 1

Value	Eng unit
	%
	Bar graph

If 4.5.1.1 (Line 1 Local) = Level

4.5.1.3: Level Parameter (= Parameter 4.2.4)

If 4.5.1.1 (Line 1 Local) = Volume

4.5.1.3: Volume Parameter (= Parameter 4.2.5)

If 4.5.1.1 (Line 1 Local) = Mass

4.5.1.3: Mass Parameter (= Parameter 4.2.6)

4.5.1.4: Line 2 Local (F = S/N ratio)

Display in line 2

Value	Level
	Volume
	Mass
	Temperature
	Validity
	S/N ratio
	Amplitude
	Digital output
	Analog output

Note: Parameter 4.5.1.5 is displayed if Parameter 4.5.1.4 (Line 2 Local) = Level, Volume, or Mass.

If 4.5.1.4 (Line 2 Local) = Level

4.5.1.5: Level Parameter (= Parameter 4.2.4)

If 4.5.1.4 (Line 2 Local) = Volume

4.5.1.5: Volume Parameter (= Parameter 4.2.5)

If 4.5.1.4 (Line 2 Local) = Mass

4.5.1.5: Mass Parameter (= Parameter 4.2.6)

4.5.2: Language Local (= Parameter 1.1)

4.5.3: LCD Backlight (F = off)

Background illumination of the LCD

Value	On
	Off

4.6: Device Information

4.6.1: Power Supply (according to customer specifications)

Voltage range of the built-in power supply unit

Value	non-editable
-------	--------------

4.6.2: Process Temperature (according to customer specifications)

Temperature range of the flange in °C

Value	non-editable
-------	--------------

4.6.3: Electrical Connection (according to customer specifications)

Value	non-editable
-------	--------------

4.6.4: Antenna and Flange

4.6.4.1: Flange Size (according to customer specifications)

Size of the flange

Value	DN 50, 2"
	DN 80, 3"
	DN 100, 4"
	DN 150, 6"
	Special design

4.6.4.2: Flange Type (according to customer specifications)

Type of flange

Value	DIN 2527
	ANSI
	JIS
	Special design

4.6.4.3: Pressure Stage (according to customer specifications)

Pressure range of the process connection

Value	non-editable
-------	--------------

4.6.4.4: Antenna Type (according to customer settings)

Value	Horn type 2" (51 mm)
	Horn type 3" (76 mm)
	Horn type 4" (102 mm)

4.6.4.5: Antenna Extensions (for qualified personnel only)

This parameter is for Factory Authorized Personnel Only.

4.6.4.6: Flange Material (according to customer specifications)

Value	304
	316/316L
	Special design

4.6.4.7: Seal Material (according to customer specifications)

Sealing material

Value	PTFE
	FKM

4.6.5: Tag (according to customer specifications)

Device identification

Value	up to any eight characters
-------	----------------------------

4.6.6: Descriptor (according to customer specifications)

Measuring point description

Value	up to any 16 characters
-------	-------------------------

4.6.7: Message (according to customer specifications)

Measuring point message, e.g. the date of the last check or clean

Value	Up to any 32 characters
-------	-------------------------

4.6.8: Manufacturer Identification

4.6.8.1: Serial Number (F = unique number)

Factory serial number

Value	non-editable
-------	--------------

4.6.8.2: Order Number (according to customer specifications)

Device order number (delivery state)

Value	non-editable
-------	--------------

4.6.8.3: Fld Device Revision (F = Number)

Device version

Value	non-editable
-------	--------------

4.6.8.4: Software Revision (F = Number)

Value	non-editable
-------	--------------

4.6.8.5: Hardware Revision (F = Number)

Value	non-editable
-------	--------------

4.6.8.6: Antenna Offset (F = approx. 0.5 m [calibration value])

Distance from sensor to flange

The antenna offset defines the propagation time of the measuring signal between the sensor and the flange as a distance. It is preset at the factory and cannot be changed.

4.6.8.7: Reference Difference (F = approx. 106 m [calibration value])

Internal reference distance

The length of the reference distance in the units system selected according to Parameter 4.1.5 is view-only. The device uses this value to calibrate itself so that no manual adjustment is necessary in long-term operation.

5. Options

5.1: Enter Code

Input of customer code to enable programmability

Value	Customer code
-------	---------------

The device compares a code number which you enter here with the code defined in Parameter 5.2. If your entry matches the customer code completely, it releases the programming lock for all parameters. Any other code number locks and disables programming.

5.2: Customer Code (F = 0)

Determination of customer code

Value	Up to 9-digit code
-------	--------------------

Here you define the customer code (up to nine digits), with which you can protect the device parameters against programming errors. It is strongly recommended that a customer code be entered after all programming is completed to secure the programmed values from changes.

Use of the customer code is explained in Disabling and Enabling Programming on page 29.

5.3: Factory Reset (F = no)

Reset all parameters to factory setting

Value	Yes
	No

This parameter allows you to reset all parameters to the original factory setting as described in Parameters (HART) beginning on page 32.

DRAFT

Parameters (PROFIBUS PA)

Parameters (PROFIBUS PA)

Note: For parameter descriptions, please refer to the associated HART parameters on pages 30 to 58.

Parameter, menu identification	Description	Factory Setting	Setting Possibilities
1: Auto-Setup			
Language local	Language of the local user interface	English	English Deustch
Length unit		m	cm m mm ft in
Nozzle height	Height flange to top of tank	0 m	numerical value
Tank height	Height tank bottom to top	20 m	numerical value
Level URV	Full scale of level (see Functional Dimensions Diagram on page 33)	20 m	numerical value
Level LRV	Start of scale of level (See Functional Dimensions Diagram on page 33)	0 m	numerical value
Level damping	Damping of level in s	1 s	numerical value
Application type	Use of the vessel	Liquid (process)	Liquid (store) Liquid (process) Silo1 (solids) Silo2 (solids) User tank1 User tank2
Bus address	Current bus address	126	0 to 126
2: Display			
2.1: Multi-display	Display of two measured values	Level/Signal-to-noise ratio in dB	non-editable
2.2: Level	Level of measured medium	m	non-editable
2.3: Volume	Volume of measured medium	m ³	non-editable
2.4: Mass	For qualified personnel only		

Parameters (PROFIBUS PA)

Note: For parameter descriptions, please refer to the associated HART parameters on pages 30 to 58.

Parameter, menu identification	Description	Factory Setting	Setting Possibilities
3: Diagnostics			
3.1: Status			
3.1.1: Wear			
3.1.1.1: Operating hours	Total previous operating time of the device in hours (approximate value)		non-editable
3.1.1.2: Maximum temp.	Previous maximum temperature of device	26°C	non-editable
3.1.1.3: Minimum temp.	Previous minimum temperature of the device	26°C	non-editable
3.1.1.4: Aging	Approximate value for the previous life of the device in % (100% = approx. 10 years)		non-editable
3.1.1.5: Hours > 85°C	Previous time during which the maximum permissible sensor temperature was exceeded in hours		non-editable
3.1.x: Sensor and/or	Diagnostic messages of the sensor		non-editable
3.1.x: Electronics and/or	Diagnostic messages of the electronics		non-editable
3.1.x: Software and/or	Diagnostic messages of the software		non-editable
3.1.x: Application and/or	Diagnostic messages to the application		non-editable
3.1.x: Parameters and/or	Display of the false parameters		non-editable
3.1.x: Service	For qualified personnel only		non-editable
3.2: Device test			
3.2.1: Self-test	Check device state		non-editable
3.2.2: Display test	Visual check of LCD		non-editable
3.3: Sensor variables			

Parameters (PROFIBUS PA)

Note: For parameter descriptions, please refer to the associated HART parameters on pages 30 to 58.

Parameter, menu identification	Description	Factory Setting	Setting Possibilities
3.3.1: Raw value	Distance from flange to measured medium		
3.3.2: Echo amplitude	Measure of quality of reflection		
3.3.3: S/N ratio	Signal-to-noise ratio of the measured value in dB		
3.3.4: Validity	Validity of the measured value in %		
3.3.5: Sensor temp	Sensor temperature		
4: Device data			
4.1: Units			
4.1.1 Length unit	= [1.2]		
4.1.2: Volume unit		m ³	bbl yd ³ ft ³ in ³ bush bbl (fl.) l m ³ hL Gal ImpGal
4.1.3: Mass unit	For qualified personnel only		
4.1.4: Temperature unit	Unit of the sensor temperature	°C	°C °F K
4.1.5: Other units	Units system for all other units	SI	SI unit US/UK unit
4.2: Operating parameters			
4.2.1: Tank geometry			
4.2.1.1: Nozzle height	= [1.3]		
4.2.1.2: Tank height	= [1.4]		
4.2.1.3: Stilling pipe? [Liquids]	Stilling pipe available?	no	yes no

Parameters (PROFIBUS PA)

Note: For parameter descriptions, please refer to the associated HART parameters on pages 30 to 58.

Parameter, menu identification	Description	Factory Setting	Setting Possibilities
If yes, 4.2.1.3.2: Pipe diameter [Liquids]	Diameter (internal) of the stilling pipe	100 mm	numerical value
4.2.2: Measuring conditions			
4.2.2.1: Applic. type	Use of the tank	Liquid (process)	Liquid (store) Liquid (process) Silo1 (solids-pellets) Silo2 (solids-powders) User tank1 User tank2
4.2.2.2: Surface	Surface structure of the measured medium Not displayed if a user tank is selected in [4.2.2.1].	wavy	smooth wavy turbulent
4.2.2.3: Dead band	Area beneath the flange in which measured values are ignored	0.4 m	numerical value, Minimum value = Length of the antenna
4.2.2.4: Correction factor	Correction factor for physical measuring influences	1.0	numerical value
4.2.2.5: Filling speed	Typical speed of change of the level Not displayed if a user tank is selected in [4.2.2.1].	200 mm/min	numerical value
4.2.2.6 Reflectivity	For qualified personnel only		
4.2.2.7: Failsafe level	Selects the default measurement in the event the failsafe timer expires	Hold	100 % 0 % Hold
4.2.2.8: Failsafe timer	Sets the time delay, in minutes, before going into fail-safe level	10 min	1 min 2 min etc.
4.2.2.9: Range extension	Sets the distance below the tank height included in the evaluation	3 m	1 m 2 m etc.

Parameters (PROFIBUS PA)

Note: For parameter descriptions, please refer to the associated HART parameters on pages 30 to 58.

Parameter, menu identification	Description	Factory Setting	Setting Possibilities
4.2.3: Sensor parameter			
4.2.3.1: Sensor damping	Averaging of measuring signal Not displayed if a user tank is selected in [4.2.2.1].	1 s	numerical value
4.2.3.2: Multiple echo	Evaluate multiple echo	on	on off
4.2.3.3: Echo motion	Evaluate echo motion	on	on off
4.2.3.4: Window tracking	Evaluate moving targets	off	on off
4.2.3.5: Tank empty detect	For qualified personnel only		
4.2.3.6: Auto fix distance	For qualified personnel only		
4.2.3.7: Fix Dist List	For qualified personnel only		
4.2.3.7.1 to 4.2.3.7.9: Fix Dist List values	For qualified personnel only		
4.2.3.8: Auto False Echo suppression	Learns and records the current signal up to the suppression distance setting. These signals are then ignored during operation.	use	use record off
4.2.3.9: Auto False Echo suppression distance	Defines the end point of the Auto False Echo suppression distance	2/3 tank height	variable
4.2.3.A Hover level	Defines (in %) how high the TVT curve is placed above echo profile, relative to largest echo	40%	0 to 100%
4.2.3.B Window Trigger	Defines position of window on leading edge of selected echo, relative to amplitude	80%	0 to 100%
4.2.4: Level param.			
4.2.4.1: Level URV	= [1.5]		

Parameters (PROFIBUS PA)

Note: For parameter descriptions, please refer to the associated HART parameters on pages 30 to 58.

Parameter, menu identification	Description	Factory Setting	Setting Possibilities
4.2.4.2: Level LRV	= [1.6]		
4.2.4.3: Level damping	= [1.7]		
4.2.4.4: MinWarn level	Limit before reaching lower limit value	0 m	numerical value
4.2.4.5: MinLim level	Lower limit value of the level (See Functional Dimensions Diagram)	0 m	numerical value
4.2.4.6: MaxLim level	Upper limit value of the level (See Functional Dimensions Diagram)	20 m	numerical value
4.2.4.7: MaxWarn level	Limit before reaching upper limit value	20 m	numerical value
4.2.4.8: HYST level	Hysteresis of the level limit values	0.5 m	numerical value
4.2.5: Volume param.			
4.2.5.1: Volume URV	Full scale of the volume	20 m ³	numerical value
4.2.5.2: Volume LRV	Start of scale of the volume	0 m ³	numerical value
4.2.5.3: Volume damping	Damping of the volume	1 s	numerical value
4.2.5.4: MinWarn volume	Limit before reaching lower limit value	0 m ³	numerical value
4.2.5.5: MinLim volume	Lower limit value of the volume	0 m ³	numerical value
4.2.5.6: MaxLim volume	Upper limit value of the volume	20 m ³	numerical value
4.2.5.7: MaxWarn volume	Limit before reaching upper limit value	20 m	numerical value
4.2.5.8: HYST volume	Hysteresis of the volume limit values	0.5 m ³	numerical value
4.2.5.9: Tank characteristic	Determining the tank characteristic	Calculate	Calibrate/table Calculate
4.2.5.A: Calibrate/table or 4.2.5.A: Calculate			

Parameters (PROFIBUS PA)

Note: For parameter descriptions, please refer to the associated HART parameters on pages 30 to 58.

Parameter, menu identification	Description	Factory Setting	Setting Possibilities
4.2.5.A.1: Calibrate or 4.2.5.A.1: Tank design	Automatic ltering		Confirm input
		Vertical cylinder	Linear Vertical cylinder Horizontal Cylinder Sphere
4.2.5.A.2: Enter table or 4.2.5.A.2: Bottom design	Manual entry of a table		numerical value
		Dished end	Dished end Basket end Bullet bottom
4.2.5.A.3: Show table or 4.2.5.A.3: Tank volume	Display table		Selection
		20 m ³	numerical value
4.2.5.A.4: Clear table or 4.2.5.A.4: Tank height	Delete table		Selection
	= [4.2.1.2]		
4.2.6: Mass Parameters	For qualified personnel only		
4.2.6.1: Mass URV	For qualified personnel only		
4.2.6.2: Mass LRV	For qualified personnel only		
4.2.6.3: Mass damping	For qualified personnel only		
4.2.6.4: MinWarn Mass	For qualified personnel only		
4.2.6.5: MinLim mass	For qualified personnel only		
4.2.6.6: MaxLim mass	For qualified personnel only		
4.2.6.7: MaxWarn Mass	For qualified personnel only		
4.2.6.8: HYST Mass	For qualified personnel only		
4.2.6.9: Tank Character	For qualified personnel only		
4.2.6.A: Calibrate/table or 4.2.6.A: Calculate			
4.2.6.A.1: Calibrate or 4.2.6.A.1: Tank design	For qualified personnel only		
	For qualified personnel only		

Parameters (PROFIBUS PA)

Note: For parameter descriptions, please refer to the associated HART parameters on pages 30 to 58.

Parameter, menu identification	Description	Factory Setting	Setting Possibilities
4.2.6.A.2: Enter table or 4.2.6.A.2: Bottom design	For qualified personnel only		
	For qualified personnel only		
4.2.6.A.3: Show table or 4.2.6.A.3: Tank volume	For qualified personnel only		
	For qualified personnel only		
4.2.6.A.4: Clear table or 4.2.6.A.4: Tank height	For qualified personnel only		
	For qualified personnel only		
4.2.6.B: Density	For qualified personnel only		
4.2.7.x: User Parameters 1	For qualified personnel only		
4.2.8.x: User Parameters 2	For qualified personnel only		
4.3: Output parameter			
4.3.1: BusIdentNr.			Profile specific Manufacturer specific
4.3.2: Bus address	= [1.8]		
4.4: Display param.			
4.4.1: Multi display			
4.4.1.1: Line 1 local	Choice of measured value in line 1	Level	Level Volume Mass
4.4.1.2: Display local	Method of display in line 1	Eng unit	Eng unit % Bargraph
4.4.1.3: Level param. or 4.4.1.3: Volume param. or 4.4.1.3: Mass param.	= [4.2.4]		
	= [4.2.5]		
	= [4.2.6]		

Parameters (PROFIBUS PA)

Note: For parameter descriptions, please refer to the associated HART parameters on pages 30 to 58.

Parameter, menu identification	Description	Factory Setting	Setting Possibilities
4.4.1.4: Line 2 local	Display in line 2	S/N ratio	Level Volume Mass Temperature Validity S/N ratio Amplitude Digital output Analog output
4.4.1.5: Level param. or 4.4.1.5: Volume param. or 4.4.1.5: Mass param.	= [4.2.4]		
	= [4.2.5]		
	= [4.2.6]		
4.4.2: Language local	= [1.1]		
4.4.3: LCD backlight	Background illumination of the LCD	off	on off
4.5: Device info			
4.5.1: Power supply	Voltage range of the built-in power supply unit	according to customer specifications	non-editable
4.5.2: Process temperature	Temperature range of the flange in °C	according to customer specifications	non-editable
4.5.3: Electrical connection		according to customer specifications	non-editable
4.5.4: Antenna and flange			
4.5.4.1: Flange size	Rated size of the flange	according to customer specifications	DN 50, 2" DN 80, 3" DN 100, 4" DN 150, 6" Special design

Parameters (PROFIBUS PA)

Note: For parameter descriptions, please refer to the associated HART parameters on pages 30 to 58.

Parameter, menu identification	Description	Factory Setting	Setting Possibilities
4.5.4.2: Flange type	Type of flange	according to customer specifications	DIN ANSI JIS Special design
4.5.4.3: Pressure range	Pressure range of the process connection	according to customer specifications	non-editable
4.5.4.4: Antenna type		according to customer specifications	Horn type 2" Horn type 3" Horn type 4"
4.5.4.5: Antenna extension	For qualified personnel only		
4.5.4.6: Flange material		according to customer specifications	304 316/316L
4.5.4.7: Seal material	Sealing material	according to customer specifications	PTFE FKM
4.5.5: Tag	Device identification	according to customer specifications	up to any eight characters
4.5.6: Descriptor	Measuring point description	according to customer specifications	up to any 16 characters
4.5.7: Message	Measuring point message, e.g. the date of last check or clean	according to customer specifications	up to any 32 characters
4.5.8: Manufacturer identification			
4.5.8.1: Serial no.	Factory serial number	unique number	non-editable

Parameters (PROFIBUS PA)

Note: For parameter descriptions, please refer to the associated HART parameters on pages 30 to 58.

Parameter, menu identification	Description	Factory Setting	Setting Possibilities
4.5.8.2: Order no.	Delivery order no. (delivery state)	according to customer specifications	non-editable
4.5.8.3: Device revision	Device version	Number	non-editable
4.5.8.4: Software revision		Number	non-editable
4.5.8.5: Hardware revision		Number	non-editable
4.5.8.6: Antenna offset	Distance sensor/flange	approx. 0.5 m (calibration value)	non-editable
4.5.8.7: Reference distance	Internal reference distance	approx. 106 m (calibration value)	non-editable
5: Options			
5.1: Enter code	Input of customer code to enable programmability		Customer code
5.2: Customer code	Determination of customer code	0	up to 9 digit code
5.3: Factory reset	Reset all parameters to factory setting	no	yes no

DRAFT

The SITRANS LR 400 is factory-tested. Carefully selected components and compliance with prescribed quality standards guarantee the high reliability of the SITRANS LR 400. Please review the instructions below for troubleshooting before contacting the responsible customer services.

Classification of Faults

Faults occurring in the SITRANS LR 400 can be classified in the following groups:

- faults caused by ambient influences: over- and under-temperature, moisture, contamination by the measuring medium and other substances, mains faults, vibration
- faults in the device: display, electronics, mechanics, connections

Please try to determine the fault and localize it as accurately as possible.

If the fault cannot be eliminated with the measures described below, follow the instructions in Maintenance on page 78.

Self-test

Note: The device performs a self-test every time it is switched on. It is ready for operation when the LCD displays the multi-display.

If you get fault messages after the self-test, please proceed according to Fault Messages on page 76.

If there is a malfunction in the device, you can also activate the self-test manually with Parameter 3.2.1.

Symptoms, Causes and Their Remedy

Symptom	Possible causes	Remedy
No display on the LCD	Defective or missing power supply	Check that the power supply is connected correctly.
	LCD is defective	Connect a HART Communicator or a PC/Laptop with SIMATIC PDM software. If the device can be parameterized from there, the LCD is defective.
	Electronics are defective	Measure the analog current output. If the output current is not between $3.6 \text{ mA} < x < 22 \text{ mA}$, the electronics are defective. Replace the electronics unit as described in Maintenance on page 78.
A fault message is displayed	Internal fault	Call the fault display in Function 3.1. Proceed as described in Maintenance on page 78.

Symptom	Possible causes	Remedy
An incorrect measured value appears after Auto-Setup.	The device is not parameterized correctly according to the application	Set the device parameters and functions manually.
No measured value appears after the Auto-Setup (measured value 0 and the fault display flashes)	Internal fault	Call the fault display in Parameter 3.1. Proceed as described in Maintenance on page 78.
Material movement but output remains constant	Varying signal moves out of tracking window too frequently.	Set Window Tracking (4.2.3.4) to OFF.
SITRANS LR 400 reads 100% continually.	Check antenna for material buildup.	Clean antenna or order a purge (self-cleaning) kit.
	Nozzle interference, or end of horn is not inside vessel	Shorten nozzle or lower position of SITRANS LR 400.
SITRANS LR 400 reading stays above actual level	False echo from vessel (fixed obstruction)	Use 4.2.3.8 and 4.2.3.9 Auto False Echo Suppression function
SITRANS LR 400 reads low or empty when material level is high	Multiple or indirect echo detected instead of first echo.	Set 4.2.3.2 Multiple Echo Tracking to ON. Try using Liquid Store application type 4.2.2.1.
	Highly sloped surface	Aim the SITRANS LR 400 using shims or order an Easy Aimer kit. Contact your Siemens representative for service and possible User parameter support.
SITRANS LR 400 reading is too slow.	Damping too high	Decrease 4.2.3.1 Sensor Damping
	Window Tracking was too slow.	Decrease Level Damping Set 4.2.3.4 to OFF (Window Tracking)
SITRANS LR 400 reading is drifting	Sloped material surface	Increase damping.

Fault Messages

The device indicates faults with a flashing letter on the right of the first line of the display. It has the following meaning:

- W: Warning – device is still ready for operation but faults may occur
- F: Fault – sporadic fault, device conditionally ready for operation
- D: Continuous fault – device is not ready for operation

Under Parameter 3.1.x, you will find a fault log which indicates the type of the fault(s) that occurred. It indicates the device function status in which the fault occurred and outputs a fault message in plain text.

Possible fault messages:

Function	Message	Possible causes	Remedy
Sensor	MW cable defective	Microwave cable not connected or line break	Contact your Siemens Milltronics representative
	Sensor defective	Overtemperature in device	Contact your Siemens Milltronics representative
	Check antenna	Antenna contaminated, damaged or not mounted	Check the antenna
	Sensor too hot	Sensor temperature exceeds 85 °C	Check the max. permissible ambient and process temperature
Electronics	all messages	Internal fault	Contact your Siemens Milltronics representative
Software	all messages	Internal fault	Contact your Siemens Milltronics representative
Application	No valid meas. value	fault in fixed target detection, fault in multiple echo detection, poorly reflecting measuring medium	1 (see below)
	Tank empty detected	vessel is empty (only when sensor parameter vessel empty detection active)	Deactivate vessel empty detection if necessary
	false param.	incompatible parameters entered, e. g.: URV = LRV	Correct the parameters listed in the next function
Parameters	<Parameter to be corrected>	False parameterization	Perform the correction as indicated
Service	(various)		For service personnel only

1. Make the following modifications, starting with
 - a. Check whether the fault still occurs after every step.
 - b. Check the set measuring range and the deadband (Parameter 4.2.2.3).
 - c. Check whether the filling speed has been correctly set (Parameter 4.2.2.5).
 - d. Reduce the reflectivity (Parameter 4.2.2.6).
 - e. Switch off the automatic fixed target detection (Parameter 4.2.3.6) if necessary.
 - f. Switch off the multiple echo detection (Parameter 4.2.3.2) if necessary.

Unit Repair and Excluded Liability

All changes and repairs must be done by qualified personnel and applicable safety regulations must be followed. Please note the following:

- The user is responsible for all changes and repairs made to the device.
- All new components must be provided by Siemens Milltronics Process Instruments Inc.
- Restrict repair to faulty components only
- Do not re-use faulty components.

Maintenance

Cleaning the Antenna

If the antenna is contaminated, any built-up material can be removed using air or soft brushes. Be careful not to damage the PTFE emitter cone inside the antenna.

An optional purge kit is available from Siemens Milltronics if required. Contact your local Siemens Milltronics representative for more details.

Solids Version

If the measured material is prone to build-up, you may need to clean the antenna at regular intervals to remove buildup that may affect the measuring result. To access the antenna, the flange must be removed.

1. Disconnect the electronics by turning off the connector waveguide, located directly above the Easy Aimer ball.
2. Remove the flange bolts. (position label)
3. Lift off the process section (including antenna).
4. Remove four Hex head M5 screws holding the antenna. (position label)
5. Clean the inside of the antenna with compressed air or soft brush.
6. Reattach the antenna and tighten the screws (ensure the screws are tightened according to the torque shown opposite). (position label)
7. Insert the process section into the vessel and fasten the flange bolts. (position label)
8. Reattach the electronics to the process section

Graphic showing expanded diagram of LR 400 antenna labelled with torque of appropriate screws.

DRAFT

Glossary

Term	Explanation
Antenna offset	Propagation time of the signal in the sensor, expressed as a distance
Current limit	The maximum possible value of the output signal in fault-free operation in mA. The value of the fail signal may be above the current limit with 24 mA.
Customer code	User-defined code which protects the device against accidental programming.
Dead band	Value range below the device flange declared unmeasurable.
Echo movement	Sensor parameter for a fuzzy rule which takes into account dynamic procedures in the measuring medium, for example, and therefore rules out fixed targets.
Fixed target	Permanently installed objects inside the vessel which may cause reflective interference, e.g. struts, agitators, feed pipes etc.
FMCW method	<u>F</u> requency <u>M</u> odulated <u>C</u> ontinuous <u>W</u> ave <u>m</u> ethod
Frequency deviation	Changing the transmission frequency in the FMCW method.
Level	Distance from the LRV to the surface of the measuring medium.
LRV	Lower limit of the valid measuring range as a distance from the bottom inside of the vessel.
Measuring medium	The (solid or liquid) contents of the vessel.
Multiple echo evaluation	Sensor parameter for a fuzzy rule which detects and suppresses multiple reflections of the measuring signal at the vessel walls.
Nozzle height	Distance from the top of the inside of the vessel to the bottom of the device flange.
PELV	<u>P</u> rotected <u>E</u> xtra <u>L</u> ow <u>V</u> oltage
PTFE	Polytetrafluorethylene
SELV	<u>S</u> afety <u>E</u> xtra <u>L</u> ow <u>V</u> oltage
Signal-to-noise ratio	Measure of the strength of reflection of the measuring medium in the current measuring situation in dB.
vessel height	Distance between the floor and top of the vessel.
Triple reflector	Metal instrument formed as a cubic segment with right angles.
URV	Upper limit of the valid measuring range as a distance from the bottom inside of the vessel.
Validity	Measure of the certainty of the current measured value in %.

Appendix I: Parameter List

Note: Parameter menus are dependent on selections made by the user. In some cases, parameter menus are renumbered according to the selection made at the previous menu level. Therefore, the parameter numbering shown below includes the standard parameter numbering.

Parameter Name	Menu Identification Number	Page Number
Aging	3.1.1.4	36
Analog output	4.3	54
Antenna and flange	4.6.4	59
Antenna extensions	4.6.4.5	60
Antenna offset	4.6.8.6	61
Antenna type	4.6.4.4	60
AO select	4.3.2	54
Application type	1.8	35
Application type	4.2.2.1	42
Auto False Echo Suppression	4.2.3.8	46
Auto False Echo Suppression	4.2.3.9	47
Distance		
Auto Fix Distance	4.2.3.6	46
Auto-Setup	1	33
Bottom design (volume)	4.2.5.8.2	52
Bottom design (mass)	4.2.6.8.2	53
Calculate (volume)	4.2.5.8	51
Calculate (mass)	4.2.6.8	53
Calibrate (volume)	4.2.5.8.1	50
Calibrate (mass)	4.2.6.8.1	53
Calibrate/table (volume)	4.2.5.8	50
Calibrate/table (mass)	4.2.6.8	53
Clear table (volume)	4.2.5.8.4	51
Clear table (mass)	4.2.6.8.4	53
Correction factor	4.2.2.4	43
Current limit	4.3.4	54
Current output	2.5	36
Customer code	5.2	62
Dead band	4.2.2.3	43
Descriptor	4.6.6	61
Device data	4	40
Device Information	4.6	59
Device revision	4.6.8.3	61
Device test	3.2	38
Diagnostics	3	36
Digital output	2.6	36
Digital output	4.4	56
Display	2	35

Parameter Name	Menu Identification Number	Page Number
Display local	4.5.1.2	58
Display parameter	4.5	57
Display test	3.2.2	38
Echo amplitude	3.4.2	39
Echo motion	4.2.3.3	45
Electrical connection	4.6.3	59
Enter code	5.1	62
Enter table (volume)	4.2.5.8.2	50
Enter table (mass)	4.2.6.8.2	53
Error level (analog output)	4.3.1	54
Error level (digital output)	4.4.2	56
Error signal	4.3.5	55
Factory reset	5.3	62
Failsafe level	4.2.2.7	44
Failsafe timer	4.2.2.8	44
Filling speed	4.2.2.5	43
Fix distance list	4.2.3.7	46
Fix distance values	4.2.3.7.1 to 4.2.3.7.9	46
Flange material	4.6.4.6	60
Flange size	4.6.4.1	59
Flange type	4.6.4.2	60
Function DO	4.4.1	56
Hardware revision	4.6.8.5	61
Hours > 85°C	3.1.1.5	37
Hover level	4.2.3.A	47
HYST level	4.2.4.6	48
HYST mass	4.2.6.6	52
HYST volume	4.2.5.6	49
Language local	1.1	33
Language local (display)	4.5.2	59
LCD backlight	4.5.3	59
Length unit	1.2	34
Length unit	4.1.1	40
Level	2.2	35
Level damping	1.7	35
Level damping	4.2.4.3	47
Level LRV	1.6	34
Level LRV	4.2.4.2	47
Level parameters	4.2.4	47
Level parameter (analog output)	4.3.3	54
Level parameter (digital output)	4.4.4	57
Level parameter (line 1 local)	4.5.1.3	58
Level parameter (line 2 local)	4.5.1.5	58
Level URV	1.5	34
Level URV	4.2.4.1	47
Line 1 local	4.5.1.1	57
Line 2 local	4.5.1.4	58

Parameter Name	Menu Identification Number	Page Number
Manufacturer identification	4.6.8	61
Mass	2.4	36
Mass damping	4.2.6.3	52
Mass LRV	4.2.6.2	52
Mass parameters	4.2.6	52
Mass parameter (analog output)	4.3.3	54
Mass parameter (digital output)	4.4.4	57
Mass parameter (line 1 local)	4.5.1.3	58
Mass parameter (line 2 local)	4.5.1.5	59
Mass unit	4.1.3	40
Mass URV	4.2.6.1	52
Maximum temperature	3.1.1.2	36
MaxLim level	4.2.4.5	48
MaxLim mass	4.2.6.5	52
MaxLim volume	4.2.5.5	49
Measuring conditions	4.2.2	42
Message	4.6.7	61
Minimum temperature	3.1.1.3	36
MinLim level	4.2.4.4	48
MinLim mass	4.2.6.4	52
MinLim volume	4.2.5.4	49
Multi-display	2.1	35
Multi-display	4.5.1	57
Multiple echo	4.2.3.2	45
Nozzle height	1.3	34
Nozzle height	4.2.1.1	41
Operating hours	3.1.1.1	36
Operating Parameters	4.2	41
Options	5	62
Order no.	4.6.8.2	61
Other units	4.1.5	41
Pipe diameter (if 4.2.1.3 = yes)	4.2.1.3.2	42
Power supply	4.6.1	59
Pressure stage	4.6.4.3	60
Process temperature	4.6.2	59
Range Extension	4.2.2.9	44
Raw value	3.4.1	39
Reference distance	4.6.8.7	62
Reflectivity	4.2.2.6	44
S/N ratio	3.4.3	39
Seal material	4.6.4.7	60
Self-test	3.2.1	38
Sensor damping	4.2.3.1	45
Sensor parameter	4.2.3	44
Sensor temperature	3.4.5	40
Sensor variables	3.4	39

Parameter Name	Menu Identification Number	Page Number
Sensor, electronics, software, application, parameters and or service	31.x	37
Serial no.	4.6.8.1	61
Show table (volume)	4.2.5.8.3	52
Show table (mass)	4.2.6.8.3	53
Signal type DO	4.4.3	56
Simulate AO	3.3.1	38
Simulate DO	3.3.2	39
Simulation	3.3	38
Software revision	4.6.8.4	61
Status	3.1	36
Stilling pipe?	4.2.1.3	41
Surface	4.2.2.2	42
Tag	4.6.5	60
Tank characteristic (volume)	4.2.5.7	49
Tank characteristic (mass)	4.2.6.7	52
Tank design (volume)	4.2.5.8.1	52
Tank design (mass)	4.2.6.8.1	53
Tank empty detect	4.2.3.5	46
Tank geometry	4.2.1	41
Tank height	1.4	34
Tank height	4.2.1.2	41
Tank height (volume)	4.2.5.8.4	52
Tank height (mass)	4.2.6.8.4	53
Tank volume (volume)	4.2.5.8.3	52
Tank volume (mass)	4.2.6.8.3	53
Temperature unit	4.1.4	41
Units	4.1	40
User1 parameters	4.2.7.x	53
User2 parameters	4.2.8.x	53
Validity	3.4.4	40
Volume	2.3	36
Volume damping	4.2.5.3	49
Volume LRV	4.2.5.2	49
Volume parameters	4.2.5	49
Volume parameter (analog output)	4.3.3	54
Volume parameter (digital output)	4.4.4	57
Volume parameter (line 1 local)	4.5.1.3	58
Volume parameter (line 2 local)	4.5.1.5	58
Volume unit	4.1.2	40
Volume URV	4.2.5.1	49
Wear	3.1.1	36
Window tracking	4.2.3.4	46
Window trigger	4.2.3.B	47

Appendix II: Programming Chart

Note: Parameter menus are dependent on selections made by the user. In some cases, parameter menus are renumbered according to the selection made at the previous menu level. Therefore, the parameter numbering shown below includes the standard parameter numbering.

Menu Identification Number	Parameter Name	Value
1.1	Language local	
1.2	Length unit	
1.3	Nozzle height	
1.4	Tank height	
1.5	Level URV	
1.6	Level LRV	
1.7	Level damping	
2.1	Multi-display	
2.2	Level	
2.3	Volume	
2.4	Mass	
2.5	Current output	
2.6	Digital output	
3.1.1	Operating hours	
3.1.1.2	Maximum temperature	
3.1.1.3	Minimum temperature	
3.1.1.4	Aging	
3.1.1.5	Hours > 85°C	
3.1.x	Sensor, electronics, software, application, parameters and or service	
3.2.1	Self-test	
3.2.2	Display test	
3.3.1	Simulate AO	
3.3.2	Simulate DO	
3.4.1	Raw value	
3.4.2	Echo amplitude	
3.4.3	S/N ratio	
3.4.4	Validity	
3.4.5	Sensor temperature	
4.1	Units	
4.1.1	Length unit	
4.1.2	Volume unit	
4.1.3	Mass unit	
4.1.4	Temperature unit	
4.1.5	Other units	
4.2.1.1	Nozzle height	
4.2.1.2	Tank height	
4.2.1.3	Stilling pipe?	

Menu Identification Number	Parameter Name	Value
4.2.1.3.2	Pipe diameter (if 4.2.1.3 = yes)	
4.2.2.1	Application type	
4.2.2.2	Surface	
4.2.2.3	Dead band	
4.2.2.4	Correction factor	
4.2.2.5	Filling speed	
4.2.2.6	Reflectivity	
4.2.2.7	Failsafe level	
4.2.2.8	Failsafe timer	
4.2.2.9	Range extension	
4.2.3	Sensor parameter	
4.2.3.1	Sensor damping	
4.2.3.2	Multiple echo	
4.2.3.3	Echo motion	
4.2.3.4	Window tracking	
4.2.3.5	Tank empty detect	
4.2.3.6	Auto fix distance	
4.2.3.7	Fix distance list	
4.2.3.7.x	Fix distance values (4.2.3.7.1 to 4.2.3.7.9)	
4.2.3.8	Auto False Echo suppression	
4.2.3.9	Auto False Echo suppression distance	
4.2.3.A	Hover level	
4.2.3.B	Window trigger	
4.2.4.1	Level URV	
4.2.4.2	Level LRV	
4.2.4.3	Level damping	
4.2.4.4	MinLim level	
4.2.4.5	MaxLim level	
4.2.4.6	HYST level	
4.2.5.1	Volume URV	
4.2.5.2	Volume LRV	
4.2.5.3	Volume damping	
4.2.5.4	MinLim volume	
4.2.5.5	MaxLim volume	
4.2.5.6	HYST volume	
4.2.5.7	Tank characteristic	
4.2.5.8	Calibrate/table	
4.2.5.8.1	Calibrate	
4.2.5.8.2	Enter table	
4.2.5.8.3	Show table	
4.2.5.8.4	Clear table	
4.2.5.8	Calculate	
4.2.5.8.1	Tank design	
4.2.5.8.2	Bottom design	
4.2.5.8.3	Tank volume	
4.2.5.8.4	Tank height	
4.2.6.1	Mass URV	

Menu Identification Number	Parameter Name	Value
4.2.6.2	Mass LRV	
4.2.6.3	Mass damping	
4.2.6.4	MinLim mass	
4.2.6.5	MaxLim mass	
4.2.6.6	HYST mass	
4.2.6.7	Tank characteristic	
4.2.6.8	Calibrate/table	
4.2.6.8.1	Calibrate	
4.2.6.8.2	Enter table	
4.2.6.8.3	Show table	
4.2.6.8.4	Clear table	
4.2.6.8	Calculate	
4.2.6.8.1	Tank design	
4.2.6.8.2	Bottom design	
4.2.6.8.3	Tank volume	
4.2.6.8.4	Tank height	
4.2.6.9	Density	
4.2.7.x	User1 parameters	
4.2.8.x	User2 parameters	
4.3.1	Error Level	
4.3.2	AO Select	
4.3.3	Level parameter	
4.3.3	Volume parameter	
4.3.3	Mass parameter	
4.3.4	Current limit	
4.3.5	Error signal	
4.4.1	Function DO	
4.4.2	Error Level	
4.4.3	Signal type DO	
4.4.4	Level parameter	
4.4.4	Volume parameter	
4.4.4	Mass parameter	
4.5.1.1	Line 1 local	
4.5.1.2	Display local	
4.5.1.3	Level parameter	
4.5.1.3	Volume parameter	
4.5.1.3	Mass parameter	
4.5.1.4	Line 2 local	
4.5.1.5	Level parameter	
4.5.1.5	Volume parameter	
4.5.1.5	Mass parameter	
4.5.2	Language local	
4.5.3	LCD backlight	
4.6.1	Power supply	
4.6.2	Process temperature	
4.6.3	Electrical connection	
4.6.4	Antenna and flange	

Menu Identification Number	Parameter Name	Value
4.6.4.1	Flange size	
4.6.4.2	Flange type	
4.6.4.3	Pressure stage	
4.6.4.4	Antenna type	
4.6.4.5	Antenna extensions	
4.6.4.6	Flange material	
4.6.4.7	Seal material	
4.6.5	Tag	
4.6.6	Descriptor	
4.6.7	Message	
4.6.8	Manufacturer identification	
4.6.8.1	Serial no.	
4.6.8.2	Order no.	
4.6.8.3	Device Revision	
4.6.8.4	Software revision	
4.6.8.5	Hardware revision	
4.6.8.6	Antenna offset	
4.6.8.7	Reference distance	
5	Options	
5.1	Enter code	
5.2	Customer code	
5.3	Factory reset	

DRAFT

Appendix III

Ambient/Operating Temperature Specification

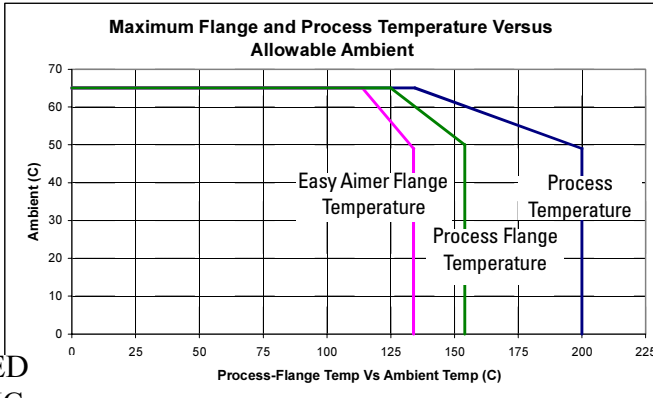

UPDATED GRAPHIC REQUIRED FOR LIQUIDS VERSION

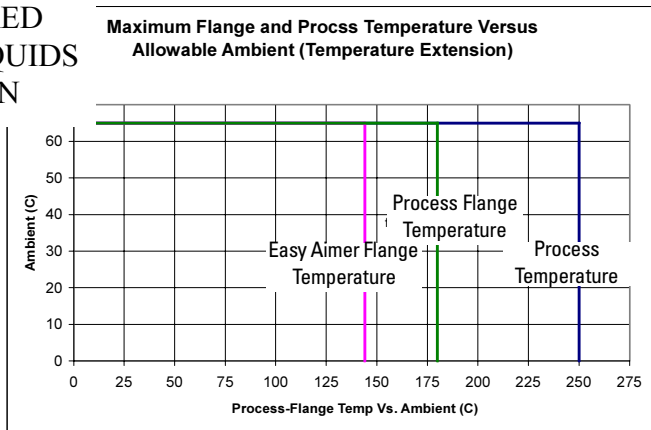

The chart above is provided for guidance only. The chart does not represent every possible process connection arrangement. The chart also does not take into consideration heating from direct sunshine exposure.

Warning: Internal temperature must not exceed 85 °C (185 °F)! Warranty may be void.

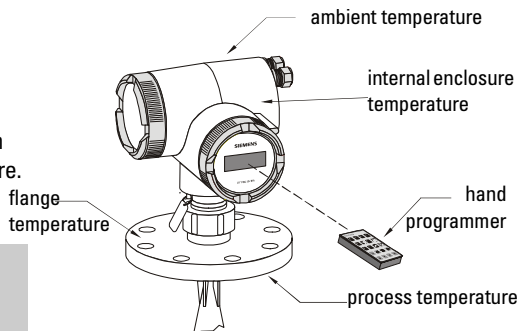

Appendix IV

IMPORTANT: The information below is not applicable to the flanges marked with serial numbers from 020102-001 to 020102-128. These flanges are intended for non-pressure applications in North America only.

! **WARNING:** Never attempt to loosen, remove, or disassemble process connection or instrument housing with vessel contents.

Process Pressure/Temperature De-rating

UPDATE
GRAPHS

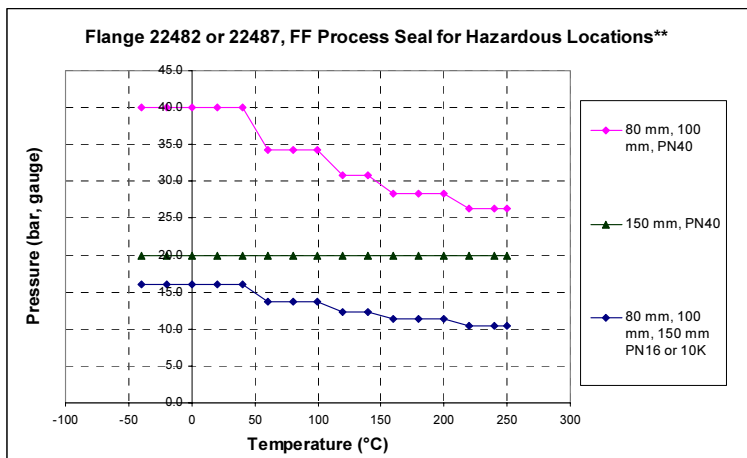
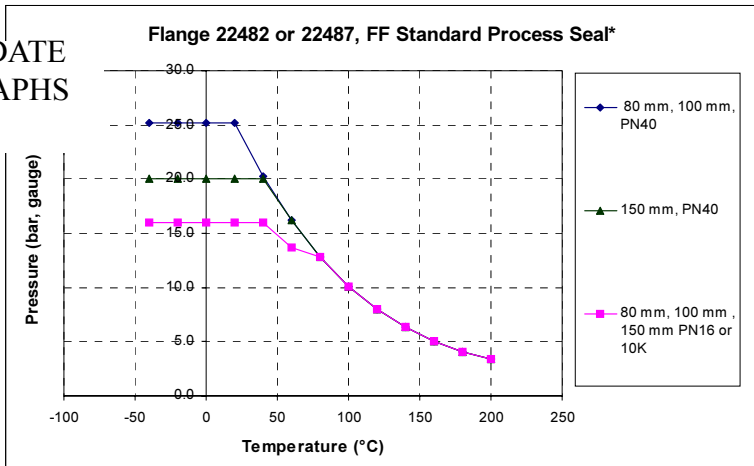

* standard process seal is rated to a max. of 200 °C of continuous duty.

**process seal for hazardous location is rated to a max. of 250 °C of continuous duty.

Appendix IV

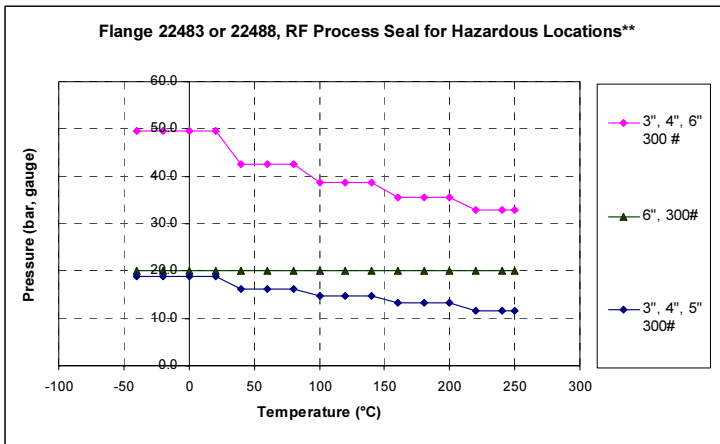
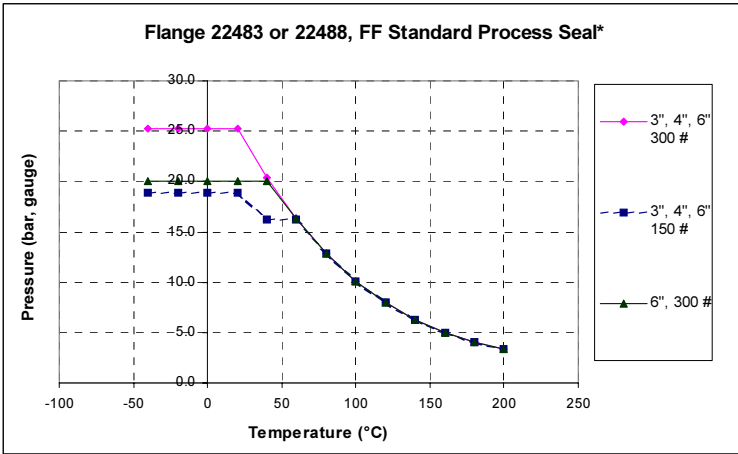

* standard process seal is rated to a max. of 200 °C of continuous duty.

** process seal for hazardous location is rated to a max. of 250 °C of continuous duty.

! WARNINGS:

- Materials of construction are chosen based on their chemical compatibility (or inertness) for general purposes. For exposure to specific environments, check with chemical compatibility charts before installing.
- The user is responsible for the selection of bolting and gasket materials which will fall within the limits of the flange and its intended use and which are suitable for the service conditions.
- Never attempt to loosen, remove, or disassemble process connection or instrument housing with vessel contents.
- Improper installation may result in loss of process pressure.

HART Communications for the SITRANS LR 400

Highway Addressable Remote Transducer, HART, is an industrial protocol that rides on top of a 4-20 mA signal. It is an open standard, and full details about HART can be obtained from the HART Communication Foundation www.hartcomm.org

The SITRANS LR 400 can be configured over the HART network using either the HART Communicator 275 by Fisher-Rosemount, or a software package. There are a number of different software packages available, and the SITRANS LR 400 should work well with any of them. The recommended software package is the SIMATIC® Process Device Manager (PDM) by Siemens.

HART Device Descriptor (DD)

In order to configure a HART device, the configurator must have the HART Device Descriptor for the unit in question. HART DDs are controlled by the HART Communications Foundation. The HART DD for the SITRANS LR 400 is available on the SITRANS LR 400 page of our website at www.siemens.com/milltronics.

Older versions of the library will have to be updated in order to use all the features in the SITRANS LR 400. If you do not see SITRANS LR 400 under Siemens Milltronics using the configurator, you will need to download an update file from our website: www.siemens.com/milltronics

SIMATIC Process Device Manager (PDM):

This software package is designed to permit easy configuration, monitoring and troubleshooting of HART and PROFIBUS PA devices. The HART DD for the SITRANS LR 400 was written with SIMATIC PDM in mind and has been extensively tested with this software. The HART DD for the SITRANS LR 400 is available on the SITRANS LR 400 page of our website at www.siemens.com/milltronics.

DRAFT

HART Communicator 275:

Chart 1

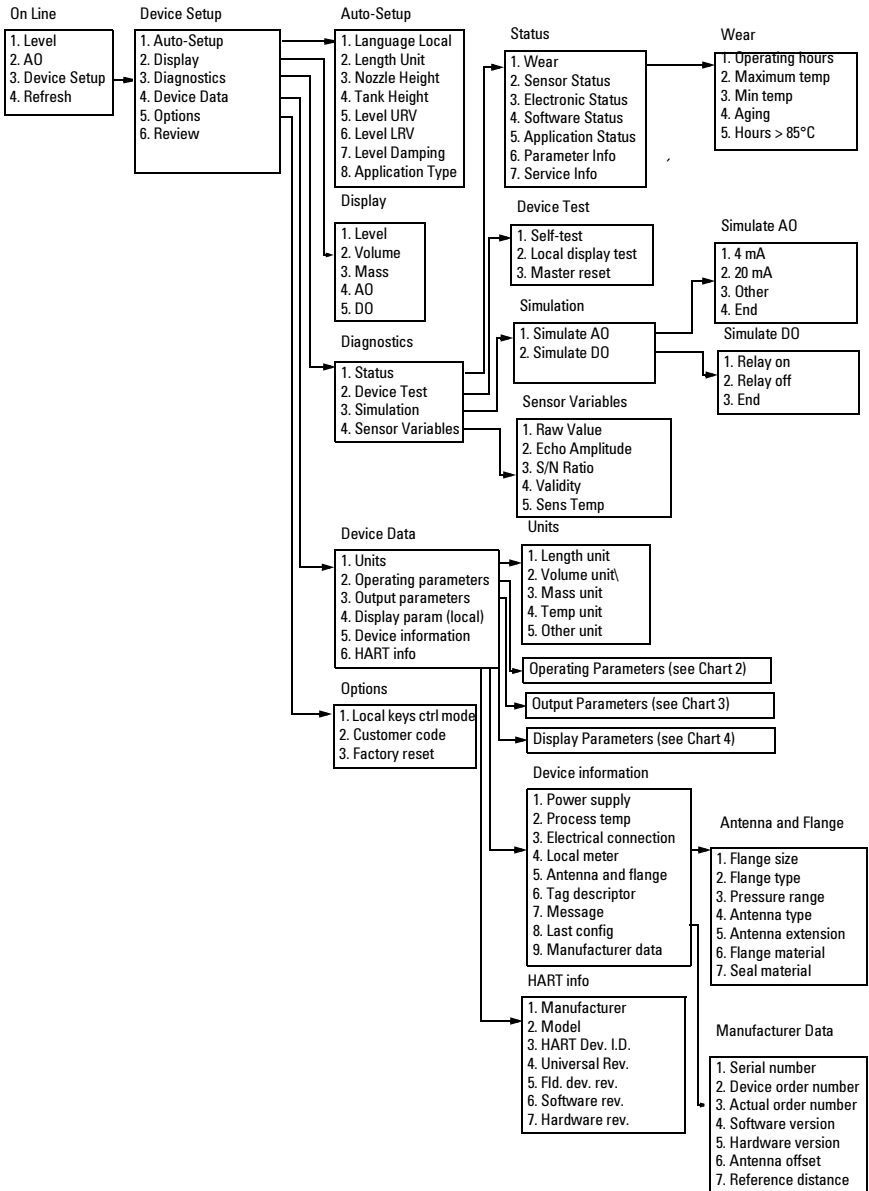

Chart 2

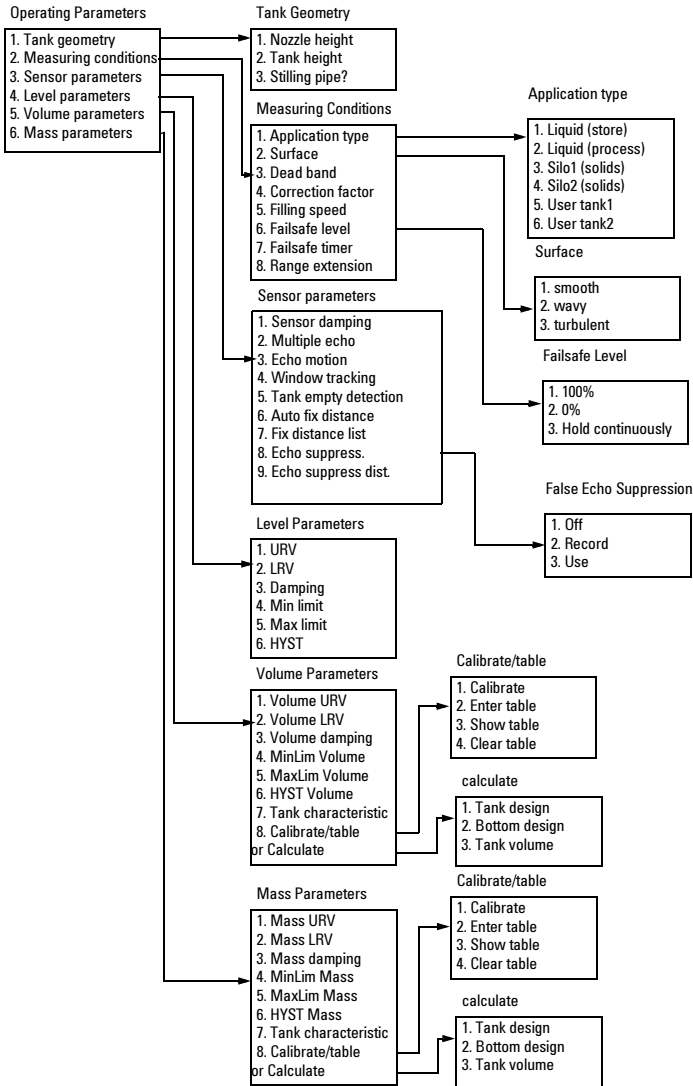

Chart 3

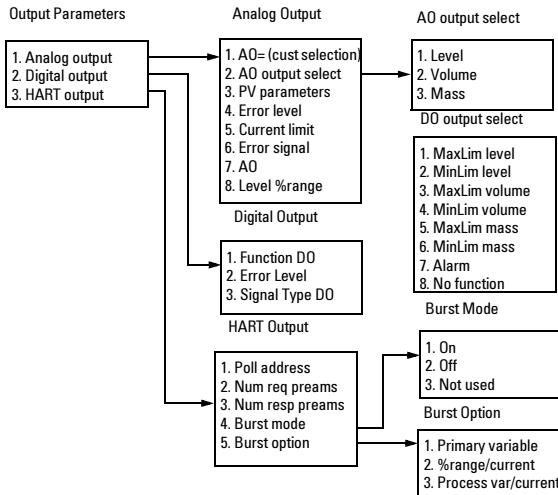
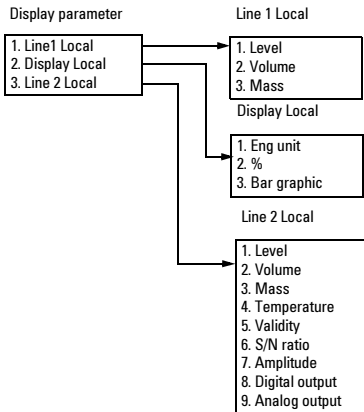

Chart 4



DRAFT

Supported HART Commands:

The SITRANS LR 400 conforms to HART rev. 5 and supports the following:

Universal Commands

0, 1, 2, 3, 6, 11, 12, 13, 14, 15, 16, 17, 18, 19

Common Practice Commands

33, 34, 35, 36, 37, 38, 40, 41, 42, 43, 44, 48, 50, 51, 53, 59, 108, 109, 110

Device Specific Commands

Command 128	Read static data material
Command 129	Write static data material
Command 130	Read dynamic variables 1
Command 131	Read dynamic variables 2
Command 132	Read tank parameters
Command 133	Write tank parameters
Command 134	Read tank design
Command 135	Write tank design
Command 136	Read calibration array
Command 137	Read calibration array
Command 138	Read stilling pipe conditions
Command 139	Write stilling pipe conditions
Command 140	Read measuring conditions
Command 141	Write measuring conditions
Command 142	Read sensor set-up 1
Command 143	Write sensor set-up 1
Command 144	Read fix distance
Command 145	Write fix distance
Command 146	Read customer code
Command 147	Write customer code
Command 148	Read sensor set-up 2
Command 149	Write sensor set-up 2
Command 150	Read analog parameters
Command 151	Write analog parameters
Command 152	Read temperature indicator
Command 154	Read trim values
Command 155	Write trim values
Command 156	Clear tank calibration
Command 157	Read device order number
Command 158	Read serial number
Command 159	Read local display select
Command 160	Write local display select
Command 161	Read display parameters
Command 162	Write display parameters
Command 163	Read digital out parameters 1
Command 164	Write digital out parameters 1
Command 165	Read digital out parameters 2
Command 166	Write digital out parameters 2
Command 167	Read lower range values
Command 168	Write lower range values

Command 169	Read upper range values
Command 170	Write upper range values
Command 171	Read damping values
Command 172	Write damping values
Command 173	Read tank characteristic set
Command 174	Write tank characteristic set
Command 175	Execute display test
Command 176	Write digital out test code
Command 177	Read digital output
Command 178	Read service information
Command 179	Read parameter information
Command 180	Read software revision
Command 181	Read hardware revision
Command 182	Write factory reset
Command 183	Read analog lost echo and range extension
Command 184	Write analog lost echo and range extension
Command 196	Read tank noise action
Command 197	Write tank noise action
Command 198	Read error level
Command 199	Write error level

The HART commands are rarely if ever used by end users. For details on the Universal and Common Practice Commands, please contact the HART Communication Foundation. For details on the Device Specific Commands, please contact Siemens Milltronics.

PROFIBUS PA Communications for the SITRANS LR 400

PROFIBUS PA is an open industrial protocol. Full details about PROFIBUS PA can be obtained from PROFIBUS International at www.profibus.com

The SITRANS LR 400 is a Class A, Profile Version 3.0, PA device. It supports Class 1 Master for Cyclic data exchange, and Class 2 for acyclic services: (See below for details).

The SITRANS LR 400 can be configured using a software package. There are a number of different software packages available and the SITRANS LR 400 should work well with any one of them. The recommended software package is the Simatic Process Device Manager (PDM) by Siemens.

Device Descriptor

In order to use Process Device Manager (PDM) with PROFIBUS PA, you will need the Device Descriptor, which will be included with new versions of PDM. Currently you can locate the Device Descriptor in Device Catalog, under Level/Echo/Siemens Milltronics. If you do not see SITRANS LR 400 under Siemens Milltronics, you will need to download an update file from the SITRANS LR 400 product page on our website: www.siemens.com/milltronics

The GSD file

The GSD file SM_062A.GSD can be obtained from Siemens Milltronics at our web site: www.siemens.com/milltronics. (There is an example on page 102, To configure and use PROFIBUS PA with an S7-300 PLC.)

Bus address (Device Address)

Values	Range: 0 to 126
	Pre-set: 126

- This value can be set via Bus Address in the Auto-setup parameters, or over the network. (After changing the value, turn the unit off and back on again in order for the change to take effect.)

DRAFT

Power Demands

The maximum number of devices that can be connected to a bus line depends on their current consumption and the respective application conditions. When operating in an area where there is no risk of explosion, the couplers/links can feed up to 400 mA into the bus.

When operating in explosion risk areas, the intrinsic safety is only guaranteed when the maximum power fed into the bus does not exceed certain voltage and current values.

These are normally:

Current $I_S < 128$ mA, voltage $U_0 < 15$ V



WARNING: Only certified supply units (DP/PA couplers or DP/PA links) may be used to feed the intrinsically safe PROFIBUS. See the EC Type Examination Certificate for requirements.

The number of devices which can be connected to a bus line is determined by finding the combined maximum current consumption of all the connected devices (10.5 mA for the SITRANS LR 400). Plan to allow a current reserve for safety.

Cyclic versus Acyclic Data

When you request data from a device via PROFIBUS PA, you have two choices. Cyclic data is provided at every bus scan: acyclic data is requested and provided as needed.

Input and output information is always requested at every bus scan and is set up as cyclic data. Configuration information is only needed periodically and is set up as acyclic data.

Cyclic Data

When you configure the SITRANS LR 400 on the PROFIBUS PA bus, there are two slots available for modules.

Note: Each of the slots has to have a module defined in it.

Slot 0 always transmits Level information and slot 1 always Volume information. Slot 2 is always Mass information. If you do not wish to have data transmitted, then you must use a Free Place module in that slot.

When you select a module, for the three values, there are two alternatives: a normal version and a short version, for example, Level (short) and Level. The difference between the two is the way each one identifies the function block used. Level uses both the identifier and the extended identifier byte to determine which function block in the unit to use. Level (short) uses only the identifier byte. In the current release of PROFIBUS PA there is no functional difference between the short and normal versions. However, the longer identifier is the preferred way to identify the function block and you should select the normal version in each case.

The 3 function blocks (Level, Volume, Mass) return 5 bytes of data each:

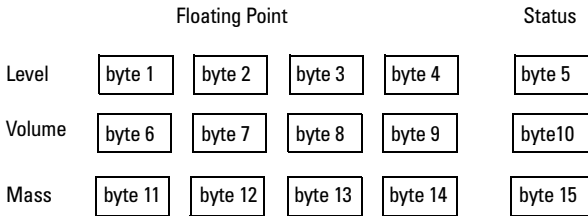

The first 4 bytes are the floating point representation (IEEE) of the variable. The variables are the outputs of the function block. The default setting for the variable level is meters. The default setting for the variable volume is m³. The default setting for the variable mass is kg. You can change the settings of the variables by changing the settings of the function block. This is typically done using PDM.

The 5th byte is the status word and the list of possible values is given in the chart on page 101.

The 5 bytes must be read consistently, in a contiguous chunk: they cannot be read byte by byte, and cannot suffer an interrupt. If you are using an S7-300/400, you will need to use SFC14 DPRD_DAT: Read Consistent Data of a Standard PD Slave.

If you select a Free Place module to fill one of the slots, this will affect the byte number.

Example 1:

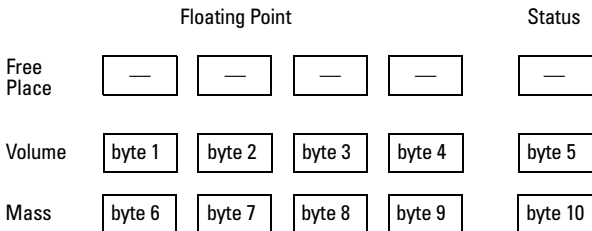

Example 2:

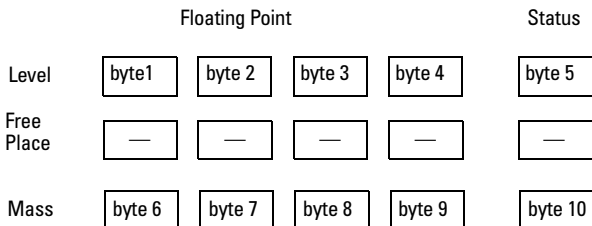

Status Word

Values in hex notation	Description
0x1F	out of service
0x0F	constant device failure
0x0C	device failure
0x13	constant sensor failure
0x12	high limited sensor failure
0x11	low limited sensor failure
0x10	sensor failure
0x07	constant configuration error
0x52	sensor conversion not accurate
0x4F	initial value
0x4C	uncertain: initial value
0x4B	substitute set
0x47	last usable value
0x42	high limited non-specific
0x41	low limited non-specific
0x40	non-specific
0x8E	high limited active critical alarm
0x8D	low limited active critical alarm
0x8A	high limited active advisory alarm
0x89	low limited active advisory alarm
0x84	active update event
0x80	ok

DRAFT

Extended Diagnostics

The last four bytes of the extended diagnostics message are as follows:

Values in hex notation	Description
0x01000000	Electronics failure
0x02000000	Mechanical failure
0x04000000	Motor Temperature
0x08000000	Electronics temperature too high
0x10000000	Memory checksum error
0x20000000	Measurement failure
0x40000000	Not initialized properly
0x80000000	Initial calibration error
0x00010000	Zero error
0x00020000	Power supply failure
0x00040000	Configuration invalid
0x00080000	Warm Start
0x00100000	Cold Start
0x00200000	Maintenance required
0x00400000	Characterization invalid
0x00000080	More information available

Acyclic Data

The SITRANS LR 400 supports up to three simultaneous connections by a class 2 Master (C2 connection). It does not support Master class 1 (C1 connection). A list of all parameters including address (slot and index), format, range of values, start value and attributes are compiled in a document which is available on request. Contact Siemens Milltronics Technical Publications at the following address: techpubs.smip@siemens.com

Configuration Example:

To configure and use PROFIBUS PA with an S7-300/400 PLC

1. Import the GSD file SM_062A.GSD from the Siemens Milltronics Web site: www.siemens.com/milltronics into Step 7 software.
2. Add the SITRANS LR 400 "rack": click and drag the SITRANS LR 400 folder from the hardware catalog.
3. Fill the rack with desired modules, by dragging and dropping them from the hardware catalog.
4. After configuring PROFIBUS PA in steps 2 and 3, download it to the PLC.
5. Add code to the PLC program to read data consistently using the SFC14.

Hazardous Installation

The necessary certificates are enclosed separately. Please refer to the SITRANS LR 400 Certificate manual 7ML19985FP82.

Certificates

DRAFT

Index

A	
analog output	54
antenna	
cleaning	78
approvals	10
auto-setup	22
B	
beam spreading	19
bus address (device address)	98
C	
certificates	103
communication	9
connection	20
PROFIBUS	5
cyclic data	99
D	
de-rating curves	90
device descriptor	98
digital output	56
dimensions	11
functional	33
display parameters	57
E	
Easy Aimer LR	13
extended diagnostics	102
F	
fault messages	76
flanges	14
FMCW	24, 79
G	
glossary	79
GSD file	98
H	
hand programmer	22, 26
HART Communications	
detailed information	92
hysteresis	48
M	
maintenance	78
mounting	
location	18
O	
operation	26
output	
analog	54
digital	56
P	
parameters	
alphabetical	80
analog output	54
auto-setup	33
digital output	56
display	57
HART	32
hysteresis	48
measuring conditions	42
PROFIBUS	63
programming chart	84
troubleshooting	37
PDM	92
PROFIBUS	63
programming	
disabling	29
enabling	29
programming chart	84
purging system	11
S	
self-test	75
SIMATIC Process Device Manager	92
specifications	6
approvals	10
communication	9
de-rating curves	90
performance	6
power	6
temperature charts	88
status word	101
structure	3
T	
troubleshooting	75

www.siemens.com/processautomation

DRAFT

Siemens Milltronics Process Instruments Inc.
1954 Technology Drive, P.O. Box 4225
Peterborough, ON, Canada K9J 7B1
Tel: (705) 745-2431 Fax: (705) 741-0466
Email: techpubs.smpi@siemens.com

© Siemens Milltronics Process Instruments Inc. 2004
Subject to change without prior notice



Printed in Canada

Rev. 5.0