



Installation Guide for:
WiN7200 Pico Base Station (pBST) Family
WiNetworks Win-Max™ 802.16e

M/N: MDOC-IG-120309

Version: 1.2

Revision: 1.0

Date: Mar 2009

Preface Material

THE SPECIFICATIONS AND INFORMATION REGARDING THE PRODUCTS IN THIS MANUAL ARE SUBJECT TO CHANGE WITHOUT NOTICE. ALL STATEMENTS, INFORMATION, AND RECOMMENDATIONS IN THIS MANUAL ARE BELIEVED TO BE ACCURATE BUT ARE PRESENTED WITHOUT WARRANTY OF ANY KIND, EXPRESSED OR IMPLIED. USERS MUST TAKE FULL RESPONSIBILITY FOR THEIR APPLICATION OF ANY PRODUCTS.

THE SOFTWARE LICENSE AND LIMITED WARRANTY FOR THE ACCOMPANYING PRODUCT ARE SET FORTH IN THE INFORMATION PACKET SHIPPED WITH THE PRODUCT AND ARE INCORPORATED HEREIN BY THIS REFERENCE. IF YOU ARE UNABLE TO LOCATE THE SOFTWARE LICENSE OR LIMITED WARRANTY, CONTACT YOUR WINETWORKS REPRESENTATIVE FOR A COPY.

NOTWITHSTANDING ANY OTHER WARRANTY HEREIN, ALL DOCUMENT FILES AND SOFTWARE OF THESE SUPPLIERS ARE PROVIDED "AS IS" WITH ALL FAULTS. WINETWORKS AND ITS SUPPLIERS DISCLAIM ALL WARRANTIES, EXPRESSED OR IMPLIED, INCLUDING, WITHOUT LIMITATION, THOSE OF MERCHANTABILITY, FITNESS FOR A PARTICULAR PURPOSE AND NONINFRINGEMENT OR ARISING FROM A COURSE OF DEALING, USAGE, OR TRADE PRACTICE.

IN NO EVENT SHALL WINETWORKS OR ITS SUPPLIERS BE LIABLE FOR ANY INDIRECT, SPECIAL, CONSEQUENTIAL, OR INCIDENTAL DAMAGES, INCLUDING, WITHOUT LIMITATION, LOST PROFITS OR LOSS OR DAMAGE TO DATA ARISING OUT OF THE USE OR INABILITY TO USE THIS MANUAL, EVEN IF WINETWORKS OR ITS SUPPLIERS HAVE BEEN ADVISED OF THE POSSIBILITY OF SUCH DAMAGES.

COPYRIGHT ©2007 WINETWORKS. ALL RIGHTS RESERVED.

WINETWORKS AND WIN-MAX™ ARE REGISTERED TRADEMARKS OF WINETWORKS AND/OR ITS AFFILIATES IN THE U.S. AND CERTAIN OTHER COUNTRIES.

Safety Information

General

Read this User Manual and follow all operating and safety instructions.

The base station and antenna must be installed by a professional installer.

The power requirements are indicated on the product-marking label. Do not exceed the described limits.

Equipment Installation

The equipment should be installed in accordance with the National Electrical Code (NEC), ANSI/NFPA 70, the Canadian Electrical Code (CEC), Part 1, CSA C22.1; and when applicable, the National Electrical Safety Code IEEE C2. And unless marked or otherwise identified, the Standard for the Protection of Electronic Computer/Data Processing Equipment, ANSI/NFPA 75.

RF Exposure

WiN7200 is compliant with the requirements set forth in CFR 47 section 1.1307, addressing RF Exposure from radio frequency devices as defined in OET Bulletin 65. The outdoor base station should be positioned more than 0.65 feet (20 cm) from humans. Lightning Protection



When Pico BST unit is installed in an outdoor location, all indoor components (Ethernet, power supply) should be connected through a lightning protector.

The purpose of the lightning protection is to protect people and equipment located indoors from lightning that might strike the Pico BST unit or its outdoor cables. Therefore, the lightning protector device should be installed indoors, as close as possible to the point where the cables enter the building. The lightning protector can also be installed outdoors, as long as the cables that go from it indoors are well protected from lightning between the box and the building entrance.

Power Cord Protection

The Win7200 should always be connected to the supplied data adapter for both power supply and data transfer purposes.

Any other type of connection/application of the WiN7200 and/or supplied data adapter is not allowed.

Route all power supply cords so that people cannot walk on them, or place objects on or against them. This can pinch or damage the cords.

Servicing

Do not open the cover of this product and attempt service unless instructed by a WiNETWORKS certified technician. Refer all repairs to qualified service personnel. Removing the covers or modifying any part of this device voids its warranty.



Keep away from electric power lines!

Carefully read and follow all instructions in this manual. By nature of the installation, you may be exposed to hazardous environments and high voltage. Use caution when installing the outdoor system.

Antenna Grounding Requirements

Verify that the antenna or cable system is grounded (earthed).

The antenna installation must be as per Article 810 of the NEC. Of particular note is the requirement that the grounding conductor not be less than 10 AWG (Cu). The scheme should be either in accordance with UL 96 and 96A. Lightning Protection Components and Installation Requirements for Lightning Protection Systems, or tested in accordance with UL 50 and UL 497.

Outdoor Grounding System



Verify that the base station is grounded.

The system must be properly grounded to protect against power surges and accumulated static electricity. It is the installer responsibility to install this device in accordance with the local electrical codes.

Safety Hazards



Warning!

- Installing Pico BST can pose a serious hazard. Be sure to take precautions to avoid the following:
- Exposure to high voltage lines during installation
- Falling when working at heights or with ladders
- Injuries from dropping tools
- Contact with AC wiring (power system connection)



Warning!

To reduce the risk of fire, only use a No. 24AWG or larger telecommunication line cord between the indoor and outdoor units.

FCC Note:

This equipment has been tested and found to comply with the limits for a Class B digital device, pursuant to Part 15 of the FCC Rules. These limits are designed to provide reasonable protection against harmful interference in a residential installation. This equipment generates, uses and can radiate radio frequency energy and, if not installed and used in accordance with the instructions, may cause harmful interference to radio communications. However, there is no guarantee that interference will not occur in a particular installation. If this equipment does cause harmful interference to radio or television reception, which can be determined by turning the equipment off and on, the user is encouraged to try to correct the interference by one or more of the following measures:

- Reorient or relocate the receiving antenna.
- Increase the separation between the equipment and receiver.
- Connect the equipment into an outlet on a circuit different from that to which the receiver is connected.
- Consult the dealer or an experienced radio/TV technician for help.



Warning!

Changes or modifications to this equipment not expressly approved by WiNetworks Ltd. could void the user's authority to operate the equipment.

About This Guide

This user guide provides essential product functionality with all the information necessary to professionally install and configure the Pico BST.

This guide is intended for experienced technicians and operators. It is assumed that the customers installing, operating and maintaining this product are familiar with WiMAX technologies and procedures.

WiN7225-2, WiN7235-2 and WiN7237-2 will be referred in this manual as WiN7200 from now on.

While some safety precautions are reviewed here, this manual assumes that installers have been trained in safe installation practices. Users, who are new to WiMAX technologies and service procedures, should not rely on this manual for comprehensive guidance.

List of Acronyms

ASN	Access Service Network
BST	Base Station
CPE	Customer Premise Equipment
FTP	File Transfer Protocol
GW	Gateway
HTTP	Hypertext Transport Protocol
IDU	Indoor Units
IEEE	Institute of Electronic and Eclectic Engineers
IP	Internet Protocol
LAN	Local Area Network
LOS	Line-of-sight
NMS	Network Management System
ODU	Outdoor Units
QoS	Quality of Service
RF	Radio Frequency
SLA	Service Level Agreements
SNMP	Simple Network Management Protocol
TCP	Transmission Control Protocol
WiMAX	Worldwide Interoperability for Microwave Access
Win-MAX™	WiNetworks WiMAX Product Family
WinMS	WiNetworks Network Management System

Table of Contents

Preface Material	II
About This Guide	VI
List of Acronyms	VII
Table of Contents	VIII
1 Introduction	10
1.1 About Pico BST	10
1.1.1 Main Features and Capabilities	11
1.2 System Architecture	11
1.3 Interfaces	12
1.3.1 Bottom Panel.....	12
1.3.2 Top Panel	13
2 Site and Installation Requirements.....	14
2.1 Pico BST Installation Location.....	14
2.1.1 Criteria for Outdoor Locations.....	14
2.1.2 Criteria for Indoor Locations.....	14
2.1.3 External GPS Antenna Installation Location	15
2.1.4 Antenna Grounding Requirements.....	15
3 Installation Procedure.....	16
3.1 Pre-Installation Safety Instructions.....	16
3.2 Unpacking	16
3.3 Required Tools and Materials.....	17
3.4 Installing the Pico BST	17
3.4.1 Overview	17
3.4.2 Cover Console Port.....	18
3.4.3 Assemble PoE Connector	18
3.4.4 Assemble Mounting Bracket	19
3.4.5 Mount the Pico BST.....	20
3.4.5.1 Wall Mount.....	20
3.4.5.2 Pole Mount	21
3.4.6 Antenna Connections.....	22

3.4.6.1 RF Connections and Grounding	22
3.4.6.2 (Optional) External GPS Antenna Connections.....	22
3.4.7 Connect the Win7200 Data Adapter	23
4 Setup.....	25
4.1 Connecting Pico BST to Web Interface.....	25
4.2 Verifying IP Connectivity	26
5 Troubleshooting.....	27
5.1 No IP connectivity	27
5.2 No Serial Connection	27
Appendix A – Specifications	28
Appendix B – IDU to ODU Cable Specifications	30
Appendix C – Console Connector	31
Appendix D - Mechanical Drawing.....	32

1 Introduction

1.1 About Pico BST

WiNetworks WiN7200 Pico WiMAX BST is a single sector station used to enhance outdoor and indoor WiMAX coverage and capacity. The unit is easily installable, powered by PoE and supports remote management.

WiN7200 provides the full base station functionality necessary for serving a single sector and is available in 2.XGHz and 3.XGHz frequency range. It supports up to 512 subscriber units and its light weight and small footprint allow it to be easily mounted by one person on poles, street lamps or walls.

The WiNETWORKS Pico BST is a member of the Win-MAX E family, a line of mobile WiMAX broadband wireless access systems based on the 802.16e mobile WiMAX standard. Win-MAX E systems are designed for robustness and simplicity, offering feature-rich services with low deployment and operation costs, for unmatched operator competitiveness and fast ROI.

WiN7200 provides all the functionality necessary to communicate with fixed and mobile subscriber units according to the service criteria and customer Service Level Agreements (SLA). The end-to-end Quality of Service (QoS) ensures the same high quality WiMAX experience is delivered to customers outside or inside his/her home or small office.

The WiN7200 is supported by WiNetworks management system – WiNMS.



Figure 1. Win7200 Pico BST

1.1.1 Main Features and Capabilities

- All outdoor, one-box Pico Base Station solution
- GPS synchronization
- NLOS
- MIMO 2x2
- Small footprint and light weight enables simple installation and deployment by a single person
- IEEE802.16e Wave2 Standard Compliance
- Backbone Ethernet connectivity via a 10/100 Base-T network interface
- Supports fixed and mobile CPEs
- Supports 5MHz,7MHz and 10MHz channel bandwidth
- Supports different RF options including 2.x, 3.x GHz bands
- Traffic classification and connection establishment initiation
- Policy-based data switching
- Quality of Service (QoS) management
- Alarms management
- An SNMP agent incorporated into the unit enables extensive In-Band (IB) management of the Base Station and all its registered CPEs
- R6 interface to ASN GW profile C

1.2 System Architecture

The Pico BST unit receives power and data over PoE.

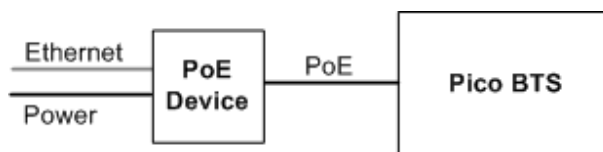

Figure 2. Block Diagram

1.3 Interfaces

The unit is installed vertically, where the integrated GPS antenna is located on the *top panel* (facing the sky). All other connections, including the optional GPS external antenna connections are located on the *bottom* panel.

1.3.1 Bottom Panel

The interface panel supports the antenna, power and Ethernet connections.



Figure 3. Pico BST Interface Panel

The following table provides a description of the Pico BST bottom panel connectors and ports.

Table 1. Bottom Panel Connectors

No.	Connector Name	Connector Type	Cable Type	Description	Connected to
1	ANT1	N type Female	RG 214/U	RF antenna connection	external antenna or Screwed-on omni-directional antenna
2	Console	RJ45	Cat5 ETH	Low level CLI for WiNetworks technical personnel. RS-232	Computer
3	DC + ETH	RJ45	Cat5 ETH	DC 1.5A + Ethernet Cat5	PoE data adaptor
4	GND	1 screw ETSI	#10 AWG bare copper wire	Grounding lug. #10 AWG bare copper wire	Central earth ground, Tower or pole chassis
5	GPS (optional)	TNC Female	RG-59	Base Station Synchronization	Optional External GPS antenna
6	ANT2	N type Female	RG 214/U	RF antenna connection	external antenna or Screwed-on omni-directional antenna

1.3.2 Top Panel

The top panel supports the built-in GPS antenna. (An external GPS antenna can be connected to the bottom panel GPS connector). See section 0 for more information on GPS antennas and installation criteria.

The figure below shows the Pico BST mounted on a pole.

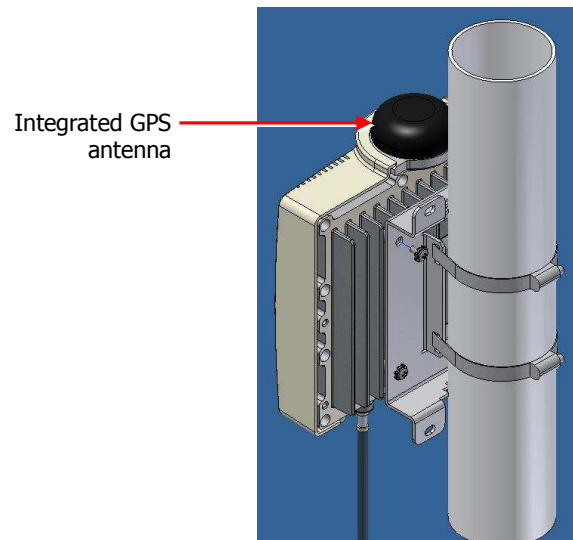

Figure 4. Top panel GPS Antenna

2 Site and Installation Requirements

2.1 Pico BST Installation Location

WARNING!

THE PICO BST UNIT MUST ALWAYS BE INSTALLED VERTICALLY AND TOP-DOWN –
WITH THE CONNECTORS ON THE UNDERSIDE FOR PROTECTION.

This section describes the criteria that should be considered when selecting the Pico BST installation location.

2.1.1 Criteria for Outdoor Locations

Take into account your site plan and local regulations that define distance from populated areas.

- The unit should be mounted in the highest possible point. Reception will increase according to the height of the antennas.
- There should be minimum obstacles between the antenna and the planned coverage area (zone) – minimum of 55% exposure to the sky.
- Take into account (according to your coverage site plan) distance from other antennas or devices that may cause interferences.
- Accessibility for maintenance (where possible).

2.1.2 Criteria for Indoor Locations

- A minimum of 55% direct LOS exposure of the external GPS antenna to sky.
- Maximum distance between external GPS antenna to WiN7200 = 22 meters.

2.1.3 External GPS Antenna Installation Location

The following criteria should be considered when selecting the GPS antenna installation site location in order to determine the optimal position for the antenna:

- Antenna visibility - The GPS antenna should be mounted in a position where at least **55%** of the antenna area is exposed to the sky.
- The distance between the GPS antenna from the Pico BSTBS should not exceed the maximum distance of **22 meters**. Otherwise, the length of the GPS antenna cable will cause interferences.

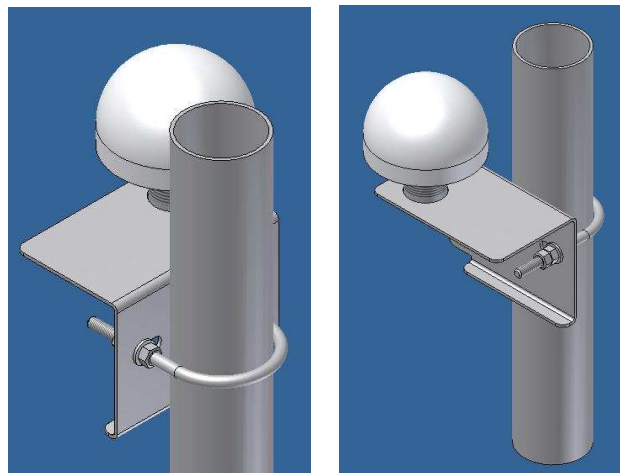

Figure 5. GPS Outer/Extension Antenna Installation

2.1.4 Antenna Grounding Requirements

The antenna installation must be as per Article 810 of the NEC. Of particular note is the requirement that the grounding conductor not be less than 10 AWG (Cu). The scheme should either correspond to UL 96 and 96A. Lightning Protection Components and Installation Requirements for Lightning Protection Systems, or tested in according to UL 50 and UL 497.

3 Installation Procedure

3.1 Pre-Installation Safety Instructions



Warning!

Before installing the Pico BST, review the following safety hazards:

- Installing Pico BST can pose a serious hazard. Be sure to take precautions to avoid the following:
- Exposure to high voltage lines during installation
- Falling when working at heights or with ladders
- Injuries from dropping tools
- Contact with AC wiring (power system connection)

3.2 Unpacking

Upon receiving the Pico BST unit, perform the following:

1. Examine the shipping container for damage before unpacking the unit.
2. Perform a visual inspection to reveal any physical damage to the equipment.

Note: In case of damage, contact the shipping company.

3. Verify that all of the equipment (listed below) is included. Otherwise contact WiNetworks.
4. The Pico BST is shipped with the following equipment:
 - WiN7200 Pico Base Station (pBST).
 - Integral 2 x omni-directional antennas (optional 65⁰ or 90⁰ single sector dual slant antenna including 2 x 1m antenna cables)
 - Data adaptor including Power Supply.
 - Internal GPS receiver and integrated GPS antenna (optional External GPS antenna with 15m cable)
 - pBST pole/wall mounting bracket.
 - Cat5 Serial cable (2m) for the console connector of the pBST (cable connectors: DB9F, RJ45)

Note: The connection between the pBST to the data adaptor is performed by a standard outdoor Cat5 Ethernet cable. The Ethernet cable is not supplied.

- Metal bands x 2 for mounting on poles
- Screws, springs and washers x 4

3.3 Required Tools and Materials

In order to install the Pico BST, a standard professional toolbox is required.

3.4 Installing the Pico BST

Note: Should be installed at highest possible point!

Important!

The equipment should be installed in compliance with the National Electrical Code (NEC), ANSI/NFPA 70, the Canadian Electrical Code (CEC), Part 1, CSA C22.1; and when applicable, the National Electrical Safety Code IEEE C2. Unless marked or otherwise identified, the Standard for the Protection of Electronic Computer/Data Processing Equipment, ANSI/NFPA 75.

There are two types of installations for the Pico BST:

- **Wall mount** - The Pico BST can be attached to any wall that can support the load of the unit.
- **Pole mount** - The unit can be attached to any pipe or pole with diameter 1.75" to 10".

3.4.1 Overview

The Pico BST installation procedure consists of the following steps:

1. Covering the Console port (only used for maintenance purposes by authorized personnel) – see 3.4.2.
2. Assembling the PoE connector – see 3.4.3.
3. Assembling the Pico BST mounting bracket – see 3.4.4.
4. Mounting the Pico BST (wall/pole mount) – See 3.4.5.
5. Antenna connections and grounding – see 3.4.6.
6. Connecting the Win7200 Data Adapter – see 3.4.7.
7. See chapter 4 for the initial Setup procedure.

3.4.2 Cover Console Port

The **Console** port is only used for maintenance operations performed by authorized service personnel and should be closed in normal conditions.

Secure the **Console** port with both of the (supplied) screws to the port panel. See figure below.



Note: See Appendix C – Console C for Console cable pin out.

3.4.3 Assemble PoE Connector

The DC/Ethernet connector that provides the PoE connection must be assembled as follows:

1. Insert the cap in to the DC/Ethernet port cover, with the as shown below.

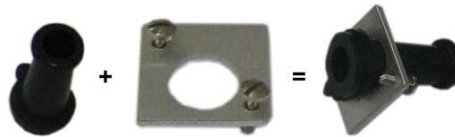

2. Insert the PoE cable (not supplied) through the cap and connect it to the supplied J45 connector.



3. Snap the J45 connector into the **DC/Ethernet** opening.

- Align the cap ridge with slot in port and insert both screws into the cover screw holes and insert in to corresponding screw holes located at the top-left and bottom-right of the **DC/Ethernet** port.

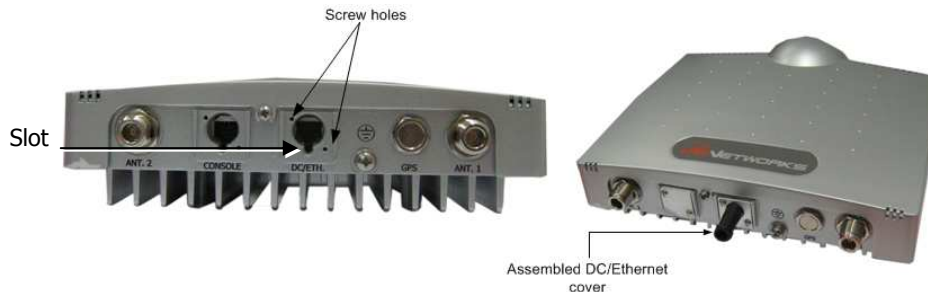

- Tighten the screws and secure cover to port.

3.4.4 Assemble Mounting Bracket

To assemble the mounting bracket on the Pico BST unit

- Align the mounting brackets' four inner holes with the Pico BST installation holes, located on the under-side of the unit (rib-side). See figure below.
- Using a Phillips screwdriver, secure the bracket to the Pico BST unit with the four screws and washers (supplied).

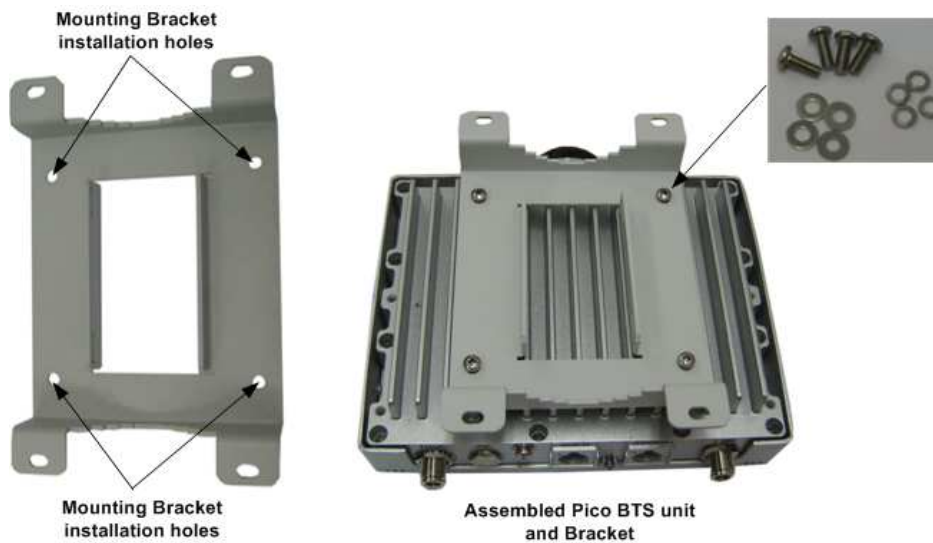

3.4.5 Mount the Pico BST

3.4.5.1 Wall Mount

Note: The Pico BST can be attached to any wall that can support the load of the unit.

To mount the unit on the wall

1. Determine the location of the Pico BST mounting bracket and mark the drilling holes on the wall surface based on the brackets' four (outer) mounting holes (two at the top and two at the bottom).

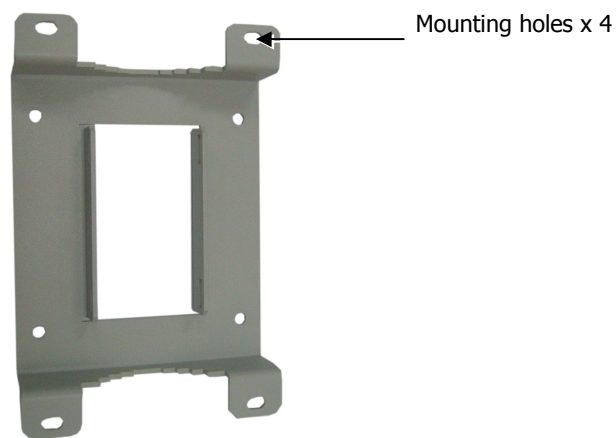

PLAN THE INSTALLATION SO THE INTERFACES FACE DOWN- PROVIDING MORE PROTECTION AGAINST THE ELEMENTS.

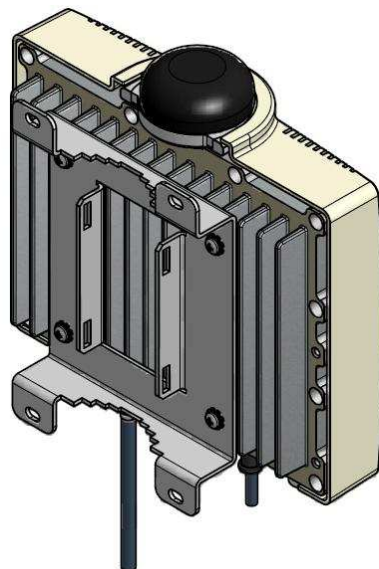

2. Drill the four holes in the wall and align the bracket installation holes with the holes in the wall. Secure with the appropriate screws and washers (not supplied).

3.4.5.2 Pole Mount

Note: The unit can be attached to any pipe or pole with a 1.75" to 10" diameter.

To mount the Pico BST on a pole

1. Assemble the wall-mounting bracket to the rear side of the unit (rib-side) – see 3.4.2.
2. Insert the metal bands in the bracket slots, as shown below.



3. Mount the unit on the pole, using the metal bands and close the bands tightly around the pole.
4. Secure the metal bands with their screws. See following figure.

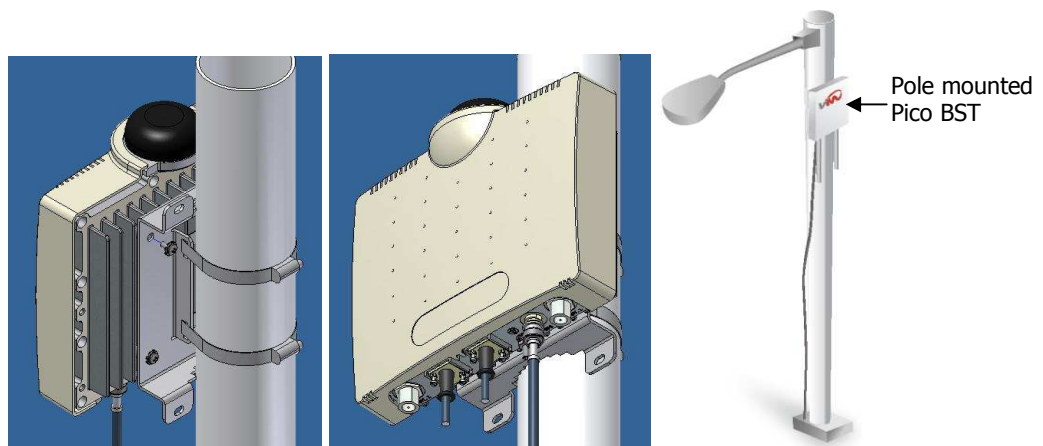

Figure 6.. Pole Mount

3.4.6 Antenna Connections

IMPORTANT!

THE PART OF THE ANTENNA THAT IS CONNECTED TO THE CENTRAL PIN OF THE ANTENNA CONNECTOR SHOULD BE COVERED BY ISOLATION MATERIAL WHICH IS SUFFICIENTLY RESISTANT TO DEGRADATION BY ULTRA-VIOLET (UV) RADIATION.

3.4.6.1 RF Connections and Grounding

Note: See 2.1.4 for antenna grounding requirements.

Connect the omni-antennas to the N-Type **ANT1** and **ANT2** connectors and connect the grounding lug to the common ground.

3.4.6.2 (Optional) External GPS Antenna Connections

Connect the **GPS** TNC connector to the external GPS antenna:

- Cable Type: RG-59
- Cable connectors: TNC
- Cable length: 15m

See figure below.

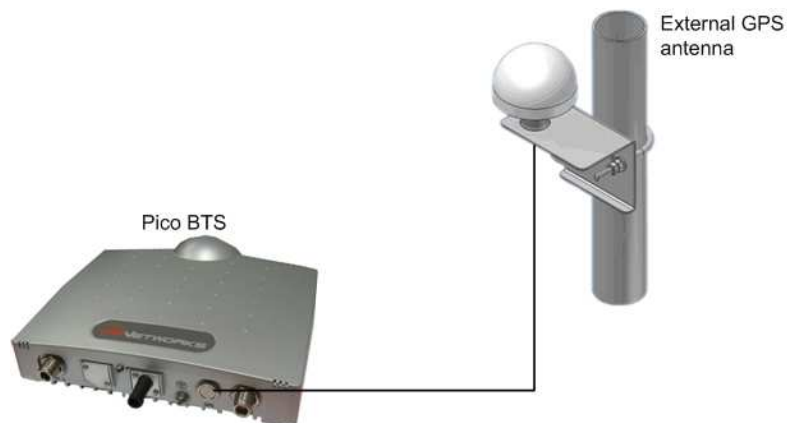

Note: The GPS port cover must be removed before interconnecting the cable between the Pico BTS and the external GPS antenna.

3.4.7 Connect the Win7200 Data Adapter

The Data Adapter is a combined data and power adapter that interfaces to the customer’s Outdoor Unit wireless device and is used to power the Win7200 and to distribute data.

The Data Adapter unit includes a single output RJ-45 connector (for connection to an IEEE802.3 compatible device) that provides bi-directional 10/100 Base-T data and power to the outdoor equipment over a Cat5e cable.

The unit receives power from 100V to 240V AC using an IEC-320-C14 industry standard connector.

Note: The AC power supply cord should be 3 wires, 18 AWG minimum, with length less than 4.5 m, safety certified according to national rules.

To connect the Win7200 Data Adapter

1. Interconnect the Win7200 Pico BST **DC/Ethernet** port and the Data Adapter **ODU IF** port, using a Cat5e cable (not supplied).

Note: The indoor to outdoor CAT5 cable max length should not exceed 100m.

Refer to the following table for the ODU I/F connector pin out.

Table 2. ODU I/F port pin-out

Pin No.	Description
1	ETH Data
2	ETH Data
3	ETH Data
4	+55V
5	+55V
6	ETH Data
7	RTN (-)
8	RTN (-)

Refer to the following figure for the Ethernet cable pin out.

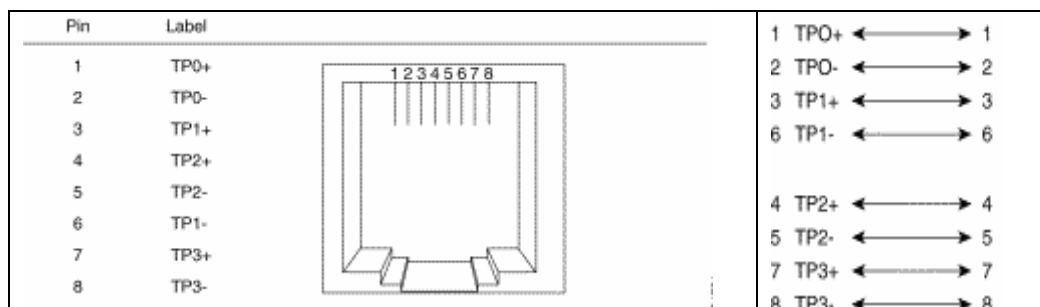

Note: The Cat5e Ethernet cable is not included. Please refer to Appendix B – IDU to ODU Cable Specifications for detailed technical specifications.

2. Connect the Data Adapter to a Switch/Router by interconnecting the Data Adapters' **Ethernet** port and the Switch/Router **10/100 Base T-port** using a Cat5e cable.
3. Connect the Data Adapter to the 110V/220V AC mains using the supplied cable.

IMPORTANT!

BEFORE CONNECTING THE DATA ADAPTER TO THE MAIN OUTLET VERIFY THAT ALL SYSTEM COMPONENTS ARE PROPERLY INSTALLED. MAKE SURE THAT ALL CABLE CONNECTORS ARE SECURELY POSITIONED IN THE APPROPRIATE PORTS.

4. Verify that the Data Adapter LEDs, located on the front panel, are *Green* indicating an OK status.

Data Adapter LED Indicators



Figure 7: Data Adapter Front Panel

The table below provides a description of the Data Adapter LED indicators.

Table 3. Data Adapter LED Description

LED	Color	Description
PWR	Green	Input power is connected
LAN	Green	LAN link/activity display
Ready	Green	System ready display

4 Setup

The initial setup procedure consists of:

- Configuring the computers' network parameters and connecting the Pico BST to the Web interface
- Verifying IP connectivity

4.1 Connecting Pico BST to Web Interface

To configure computer network parameters and connect the Pico BST unit to the Web Interface

1. Interconnect the unit and the computer Ethernet ports using the Ethernet cable.
2. Configure the computers' network parameters
 - Click the **Start** menu and choose **Control Panel**.
 - In the Control Panel, click Network and Internet Connections.
 - Click Network Connections and then double-click Local Area Connection. The Local Area Connections Properties dialog appears with the General tab displayed by default.

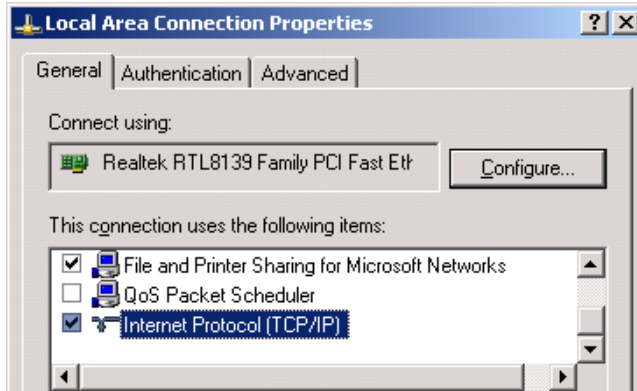

- In the Items list, select "**Internet Protocol (TCP*IP)**" and click the **Properties** button. The "Internet Protocol (TCP/IP) Properties" dialog appears.

- Assign your computer the following IP address and subnet. In the IP address area:
 - Enter the IP address **192.168.100.99**
 - Enter the subnet **255.255.255.0**

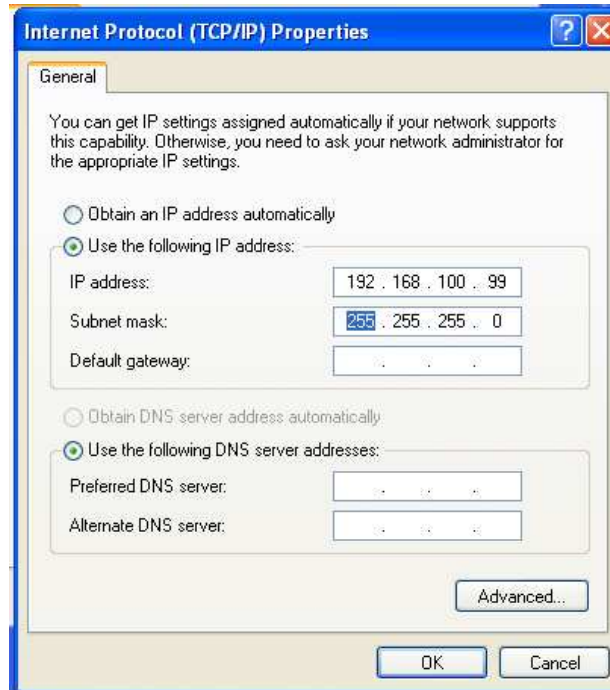

3. Open your WEB browser and enter **192.168.100.100**. The following Login window appears.

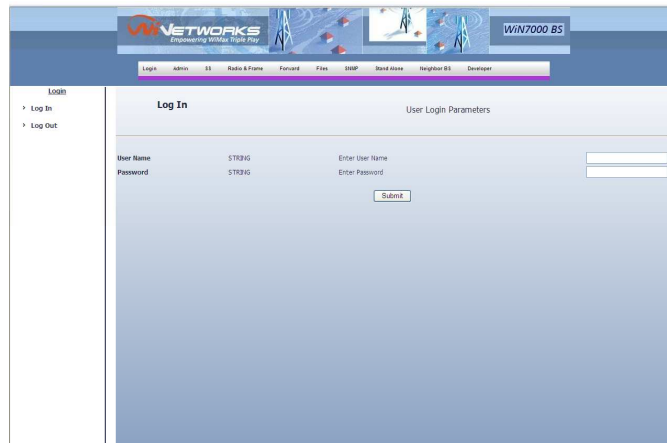

4.2 Verifying IP Connectivity

Refer to the Win7200 NMS User Manual

5 Troubleshooting

5.1 No IP connectivity

If there is no IP connectivity between the Pico BST unit and the NMS, perform the following steps:

1. Interconnect computer and Pico BST **Console** connector (serial connection), located on the units' bottom panel.
2. In the terminal type the command: **showIPAddr**. The Pico BST IP address will be displayed.
3. Try to ping the Pico BST unit address.
4. If connectivity is still not established, contact WiNETWORKS customer support

5.2 No Serial Connection

If there is no serial connection when using the serial cable perform the following:

- Verify IP connectivity using ping to the Pico BST unit IP address (see 5.1).
- If there is no IP connectivity - verify the power connections.
- If the power connections are OK, however there is still no serial connection or IP connectivity, contact WiNETWORKS customer support.

Appendix A – Specifications

Radio and Modem	
Frequency	WiN7225-2: 2496 MHz to 2690 MHz WiN7233-2: 3300 MHz to 3400 MHz WiN7235-2: 3400 MHz to 3600 MHz WiN7237-2: 3600 MHz to 3800 MHz
Radio Access Method	IEEE802.16-2005 (16e OFDMA)
Compatibility	WiMAX Forum Wave 2 Profile
Operation Mode	TDD
Channel Bandwidth	5 MHz, 7MHz, 10 MHz
Frequency Resolution	0.25 MHz
Antennas	Integral Omni (default) Attached dual slant External Sector
Number of Antennas	2
Default Antenna	Omni
Antennas Connectors	2x N-Type, 50 ohm, lightning protected
Output Power [P1dB]	2 x 5W;
Output Power (average)	26.8 dBm +/-1dB maximum
FFT/Modulation	512/1024 FFT points; QPSK, 16QAM, 64QAM
FEC	Convolution Code and Turbo Code
TPC	10dB
Synchronization	GPS or IEEE1588 (optional)
Configuration and Management	
Management	SNMP
SNMP Agent	SNMP ver 2 client: MIB II (RFC 1213), Private WiMAX MIBs
Software Upgrade	FTP
Remote Configuration	FTP
Power Interface	
Input	37-56VDC
Power Consumption	45Watt maximum
Environmental	
Operating Temperature	-40°C to +55°C
Operating Humidity	5%-95% non condensing, Weather protected
Standards and Compliances	
EMC	FCC part 15, subpart B, class B ETSI EN 301489-1/4
Safety	TUV-UL 60950-1 IEC 61950-1

Environmental	ETS 300 019: Part 2-1 T 1.2 & part 2-2 T 2.3 Part 2-4 T 4.1E
Enclosure	Type3R (IP66)
Immunity	EN61000-4-2 EN61000-4-4 EN61000-4-5
Radio	FCC Part 27 FCC Part 90 ETSI EN302 326
Ordering Information	
Part Number	WiN72XX-2-Y-ZZE-W
XX – Frequency range	See frequency table for details
Y– Sync. Interface	I – Integral GPS Antenna; G – External GPS Antenna; E – IEEE1588;
ZZ – PA peak power [W]	05
Mechanical	
Dimensions [HxWxD]	24cm x 20cm x 4cm
Weight	<4Kg

Appendix B – IDU to ODU Cable Specifications

Special 4x2x24 AWG FTP Cat. 5e Outdoor Double Jacket Data Cable UL (1581 VW 1)

Applications: Outdoor installations, Fixed or portable installations, Digital distribution frames in transmission stations, Outdoor installations in harsh environments

General Construction: Custom made cable designed specially for wireless systems, meeting the requirements of Cat. 5e per ANSI/TIA/EIA-568-B.2 and IEC 61156-5. The cable contains 4 twisted pairs, cabled, foil-tape shielded and jacketed with two special black UV resistant, flame retardant PVC compounds for direct outdoor use in harsh electrical environments. The diameter of the inner core complies with RJ45 connecting hardware allowing direct connection to equipment without patch cords.

Conductor Size: 0.52 mm

Outer Jacket Material: UV resistant FR-PVC

Outer Diameter: 7.9 mm nom.

Weight: 68.0 kg/km

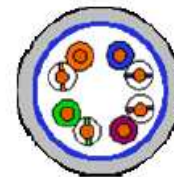

Design & Materials

Conductor Material:	Bare Copper
Conductor Size:	24 AWG
Insulation Material:	Solid PO
Insulation O.D.:	1.07 mm
Color code:	Per TIA/EIA 568-B
Overall Foil Shield:	Yes
Overall Shield Material:	Aluminum/Polyester Foil
Overall Foil Design:	100% Coverage
Overall Drain-wire Material:	Tinned Copper
Overall Drain-wire size:	24 AWG
Overall Drain-wire Construction:	Stranded
Inner Jacket Material:	UV resistant FR-PVC
Inner Jacket Diameter:	6.1 mm
Total number of wires:	8

Standards

Flamability Rating:	IEC 60332, UL 1581 VW-1
Standards:	IEC 61156, TIA/EIA-568

Performance

Frequency Range:	1 - 100 MHz
Impedance:	100 Ω
DC Resistance:	93 Ω /km nom.
Max. DC Resistance :	95 Ω /km@20°C
Capacitance Unbalance:	1.6 pF/m max.
Velocity of Propagation:	68 % nom.
Propagation Delay Skew:	35 ns/100m max.
Dielectric Strength:	700 V/minute
Dielectric Strength to Shield:	700 V/minute
Min. Bend Radius:	70 mm
Max. Operating Temperature:	+70 °C
Min. Operating Temperature:	-40 °C

Appendix C – Console Connector

Important! The Console connector should be closed in normal condition and is only intended for the use of an authorized technician.

The chassis has RJ-45 maintenance female connector, used by a technician to connect a "console".

The port is used (by maintenance personnel) to communicate with the processor when the normal management interfaces cannot be used. The console port is based on RS-232 serial standard and support a standard terminal connection.

The Console port enables the technician to configure and monitor the Pico DST unit through CLI (Command Language Interface) for low level debug.

The following table provides a description of the connector pin out.

Table 4: Maintenance connector

Pin Number	Type
1	TX
2	RX
5	GND

The serial cable used to connect the Pico BST *Console* port to the console is supplied by WiNetworks:

- **Cable Type** – Cat5
- **Cable Connectors** – DB9F; RJ45
- **Cable Length** – 2m

Appendix D - Mechanical Drawing

The following figure shows the Pico BST units' dimensions with and with the mounting bracket.

