



New York City Transit

Réf. :
Ed/Rév : 00/02
Traduction : --
Mémo :
Date : 01/28/2003

SIEMENS

Projet / Project

Arborescence / Technical number

NYL
Canarsie Line CBTC System
Contract S-32701

Type de document / *Type of document*

TITRE / TITLE

DCS RF INSTALLATION INSTRUCTIONS

Mots clés descripteurs / *Descriptors*

Rédacteur / *Author*

Nombre de pages / *Number of pages*

R. Zmudzinski

38

APPROBATION / APPROVAL

Nom / <i>Name</i>	Fonction / <i>Function</i>	Date / <i>Date</i>	Signature / <i>Signature</i>



New York City Transit

Réf. :
Trad.: --
Mémo :

Ed/Rév :00/02

Date : 01/28/2003

SIEMENS

DCS RF INSTALLATION INSTRUCTIONS

SUIVI D'EVOLUTIONS / REVISION RECORDS

<i>Edition / Révision Version number</i>	<i>Date Date</i>	<i>§ concernés Affected §</i>	<i>Modification Change</i>	<i>Justification Justification</i>
00/00DRAFT	Dec 10 th 2002	--	--	First Issue
00/01	Jan 13 th 2003			Address internal comments
00/02	Jan 28 th 2003			Additional internal comments addressed



New York City Transit

Réf. :
Trad.: --
Mémo :

DCS RF INSTALLATION INSTRUCTIONS

Ed/Rév :00/02

Date : 01/28/2003



TABLE OF CONTENTS

1. SCOPE	4
2. RELATED DOCUMENTS.....	4
3. TERMINOLOGY	4
3.1. ACRONYMS AND ABBREVIATIONS.....	4
3.2. DEFINITION	4
4. INSTALLATION INSTRUCTIONS.....	5
5. RF TEST INSTRUCTIONS (WAYSIDE).....	5
6. RF TEST INSTRUCTIONS (CARBORNE).....	9
ANNEX 1: GENRAL CONFIGURATION – PARTS LIST CONFIGURATION 1.....	11
ANNEX 2 – GENERAL CONFIGURATION – PARTS LIST CONFIGURATION 2.....	12
ANNEX 3A: GENERAL CONFIGURATION – PARTS LIST CONFIGURATION 3A	13
ANNEX 3B: GENERAL CONFIGURATION – PARTS LSIT CONFIGURATION 3B	14
ANNEX 4A: GENERAL CONFIGURATION – PARTS LIST CONFIGURATION 4A	15
ANNEX 4B: GENERAL CONFIGURATION – PARTS LIST CONFIGURATION 4B	16
13. ANNEX 5A: GENERAL CONFIGURATION – PARTS LIST CONFIGURATION 5A	17
14. ANNEX 5B: GENERAL CONFIGURATION – PARTS LIST CONFIGURATION 5B	18
15. ANNEX A: ANTENNA CONFIGURATION A	19
16. ANNEX B: ANTENNA CONFIGURATION B	20
17. ANNEX C: ANTENNA CONFIGURATION C	21
18. ANNEX D: ANTENNA CONFIGURATION D	22
19. ANNEX TR: TEST RECORD.....	23



New York City Transit

Réf. :
Trad.: --
Mémo :

DCS RF INSTALLATION INSTRUCTIONS

Ed/Rév :00/02

Date : 01/28/2003

SIEMENS

1. SCOPE

The goal of this document is to define the requirements for installation and testing of the Wayside Radio Case. It also provides the documentation procedure to insure conformance with the Radio Regulatory Authorization requirements

2. RELATED DOCUMENTS

STS Radio (WRE) User Manual
Anritsu Site Master 251C Cable Tester
FCC Interpretation Correspondence

3. TERMINOLOGY

3.1. Acronyms and abbreviations

CBTC: Communication Based Train Control
CRU: Carborne Radio Unit
EIRP: Emitted Isotropic Radiated Power
NYCT: New York City Transit
WRE: Wayside Radio Equipment, made of two WRUs
WRU: Wayside Radio Unit
WCC Wayside (radio) Cell Controller A WCC is made of two redundant WTU
WTU Wayside Transmission Unit

3.2. Definitions

Wayside Radio Unit (WRU): Chassis containing radio equipment in charge of ground-train data communications. WRUs are controlled by the Wayside Transmission Unit (WTU).

The Wayside Radio Equipment (WRE) is made of either one or two (configuration dependent) redundant WRUs and the interface board to the WTU. This is the entire equipment chassis and associated boards that are being FCC Certified. Under normal operation, only one RF Board of the WRE is active at a time.

A Wayside Cell Controller (WCC) includes two redundant WTU.



The Carborne Radio Equipment (CRE) is made of one CRU and the interface board and the subway controller. This is the entire equipment RF board chassis and associated boards that are being FCC Certified as installed in the carborne transmission unit (CTU).

Carborne Radio Unit (CRU): radio equipment in charge of train-ground data communications. CRU's are controlled by an onboard controller system.

4. INSTALLATION INSTRUCTIONS

Before installation of any WRU, the WRU will be tested at the factory to ensure each WRU is manufactured to specifications. Each WRU will be shipped with the factory test reports. Using the minimum cable path loss specified in the FCC Certification Test Report as listed in the configuration diagrams and using power measurement data collected using the following RF test instructions (power measured at WTU output connector for wayside units and at the antenna connector for carborne units) will enable the power delivered to an antenna to be calculated as needed. This technique was coordinated with the FCC and will enable compliance with the FCC requirements to be shown without the necessity of shutting down a portion of the subway to prevent endangering personnel performing measurement or maintenance tasks on the subway while the cars are in transit. The calculation will be compared to the maximum power level that may be delivered to any individual antenna whether a single antenna or one antenna in a quad array. As long as the calculated power for wayside units and measured antenna input power for carborne units is less than the maximum power permitted as listed in the TEST RECORD that was presented in the test data that formed the basis of the FCC authorization, compliance with the FCC requirements is assured.

5. RF TEST INSTRUCTIONS (WAYSIDE)

1. RF coaxial cable tests - this test will be performed using the Anritsu Site Master 251C Antenna & Cable Analyzer. The Anritsu 251C will be used to measure power output at point "A". This reading will be recorded in the WRE Power Output column of the Test Record Form in Annex TR and will use the Power Meter Function of the Anritsu 251C. The Anritsu 251C will also be used to measure reflected power in the cable system between the lightning arrester to the antenna ("B" to "C"). This reading will be recorded in the Cable Reflected Power Loss column of the Test Record Form in Annex TR. These tests will be as per Figure 5.1 & 5.2 below and are indicators of overall system quality. Shown is a dual and quad antenna array, but any configuration shown in the annexes can be used.

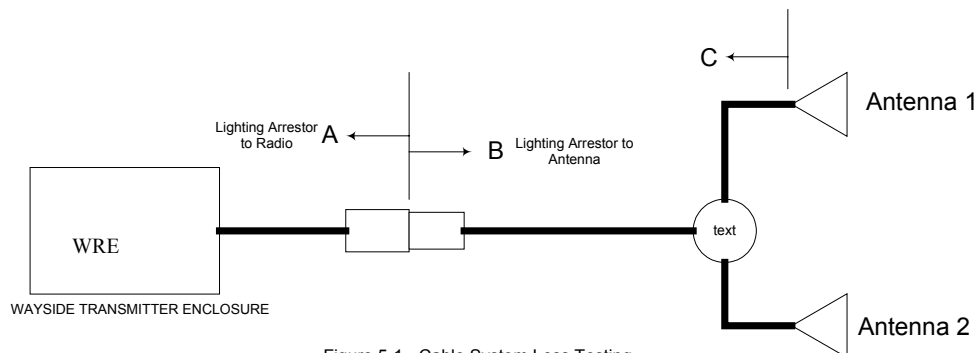

Figure 5-1 - Cable System Loss Testing



New York City Transit

Réf. :
Trad.: --
Mémo :

DCS RF INSTALLATION INSTRUCTIONS

Ed/Rév :00/02
Date : 01/28/2003

SIEMENS

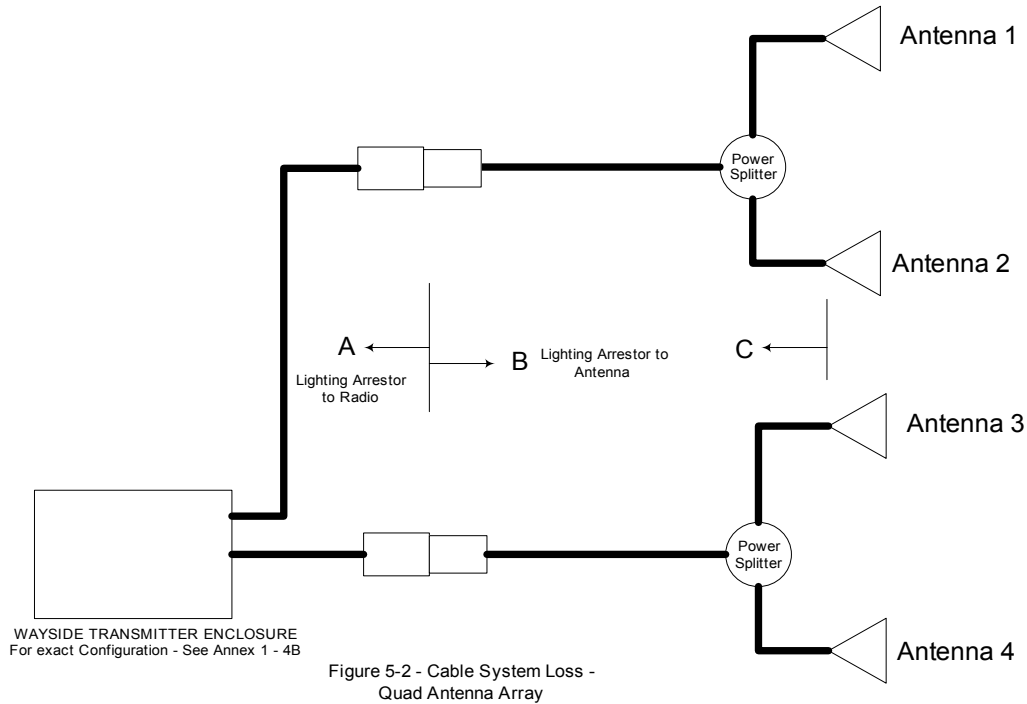

- RF measurement of the radio. This test measures the RF output of each WRE. The WRE under this test will be placed in continuous transmit mode (5 sec on/5 Sec off). Measurement will be accomplished using the RF Power Meter Option of the Anritsu Site Meter 251C. This reading will be recorded in the WRE RF Power Measurement Column of the Test Record Form in Annex TR. This value together with the minimum specified path loss for any configuration and antenna gain will be used to determine compliance with the RF output requirements. The configuration of this test is outlined in figure 5.2 below. The 1.5 meter test cable loss will be measured prior to testing and this loss will be added to the RF power output.

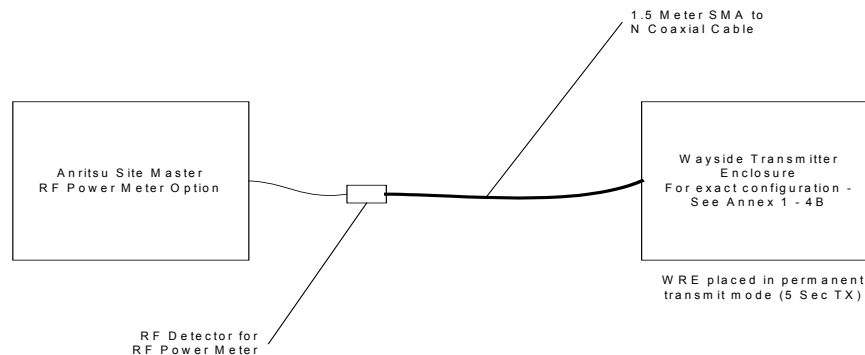

Figure 5.3 - RF Measurement of WRE



- RF measurement of system at 100 ft. This measurement will be performed using a RF Power Meter, 6 dB Horn antenna, and a 1.5 meter coaxial cable at a distance of 100 feet from the antenna (north & south). These measurements will be made with the WRE in continuous transmit mode. The measurements will be recorded in the RF Power Measurement at 100 Ft. column in the Test Record Form in Annex TR. This test is detailed in Figure 5.3 below.

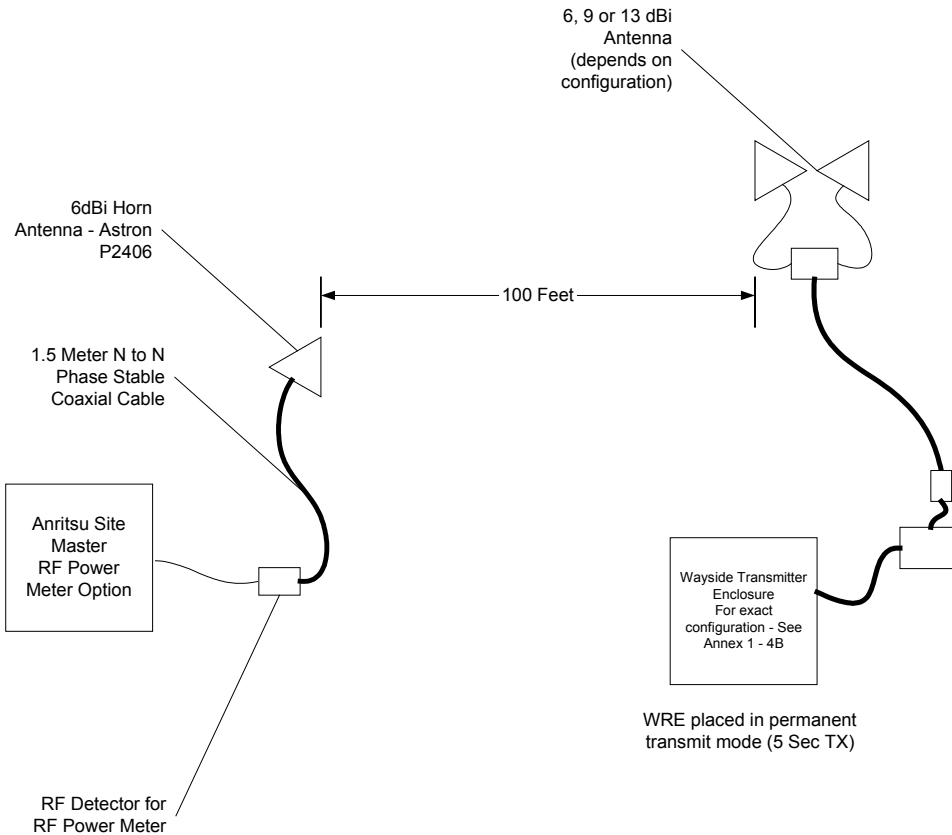

Figure 5.4 - RF Measurement of WRE w/Antenna at 100 Ft.



- RF measurement of system at 300 ft. This measurement will be performed using a RF Power Meter, 6 dB Horn antennas, and a 1.5-meter coaxial cable at a distance of 300 feet from the antenna (north & south). These measurements will be made with the WRE in continuous transmit mode. The measurements will be recorded in the RF Power Measurement Form at 300 Ft Column in Appendix F.

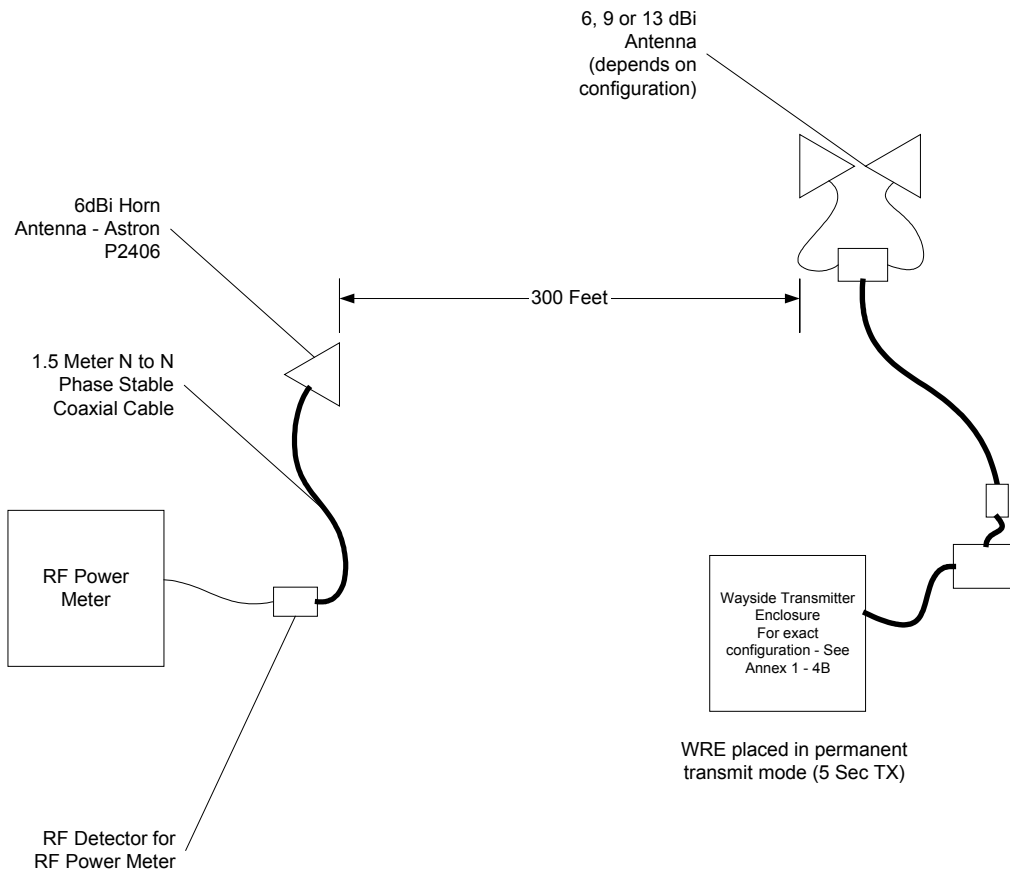

Figure 5.5 - RF Measurement of WRE w/Antenna at 300 Ft.

- During the operational life of the RF system, these tests may be conducted in any order according to maintenance activities or failure detection reports. For a specific antenna configuration, and WRE configuration, there is a minimum attenuation in the coaxial cable system between the WRE and the antenna. This is outlined in the Wayside antenna configuration guidelines.



- 6. After any maintenance activity involving a modification or change of the coaxial cable wiring or RF components, all tests will be conducted in order to check the compliance of the RF installation. The reference for all tests will be a RF configuration sheet established for each configuration. It indicates all RF characteristics of a specific configuration, and particularly the reference values used for compliance check to the FCC approval test for the specific configuration.

6. RF TEST INSTRUCTIONS (CARBORNE)

- 1. RF coaxial cable tests - this test will be performed using the Anritsu Site Master 251C Antenna & Cable Analyzer. The Anritsu 251C will be used to measure power output at point "A". This reading will be recorded in the CRE Power Output column of the Test Record Form in Annex TR and, together with antenna gain, will be used to determine compliance with the RF output power requirement. The Anritsu 251C will also be used to measure reflected power in the cable system between the lightning arrestor to the antenna ("B" to "C"). This reading will be recorded in the Cable Reflected Power Loss column of the Test Record Form in Annex TR. These tests will be as per Figure 6.1 below:

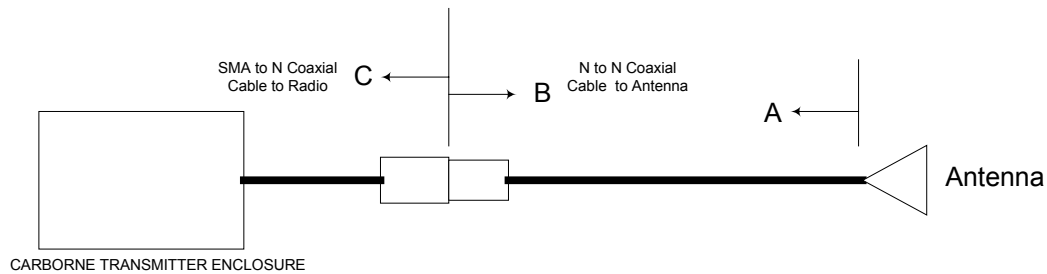

Figure 6-1 - Carborne Power Measurements

- 2. RF measurement of system at 50 ft. This measurement will be performed using a RF Power Meter, 6 dB Horn antenna, and a 1.5 meter coaxial cable at a distance of 50 feet from the antenna. These measurements will be made with the CRE in continuous transmit mode. The measurements will be recorded in the RF Power Measurement at 50-Ft. column in the Test Record Form in Annex TR. This test is detailed in Figure 6.2 below.
- 3. RF power measurement of carborne transmission unit will be made at reference point A above in continuous transmit mode. The value will be recorded in the Test Record Table for FCC compliance check.



New York City Transit

Réf. :
Trad.: --
Mémo :

DCS RF INSTALLATION INSTRUCTIONS

Ed/Rév :00/02

Date : 01/28/2003

SIEMENS

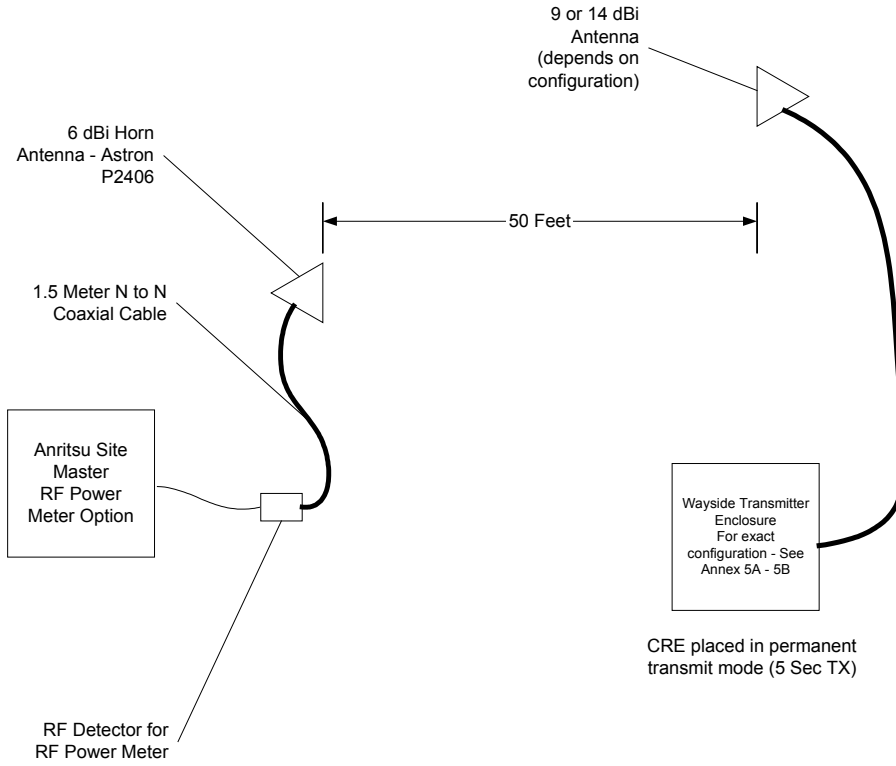

Figure 6.2 - RF Measurement of CRE w/Antenna at 50 Ft.



New York City Transit

Réf. :
Trad.: --
Mémo :

Ed/Rév :00/02
Date : 01/28/2003

SIEMENS

DCS RF INSTALLATION INSTRUCTIONS

7. ANNEX 1: GENRAL CONFIGURATION 1 – PARTS LIST

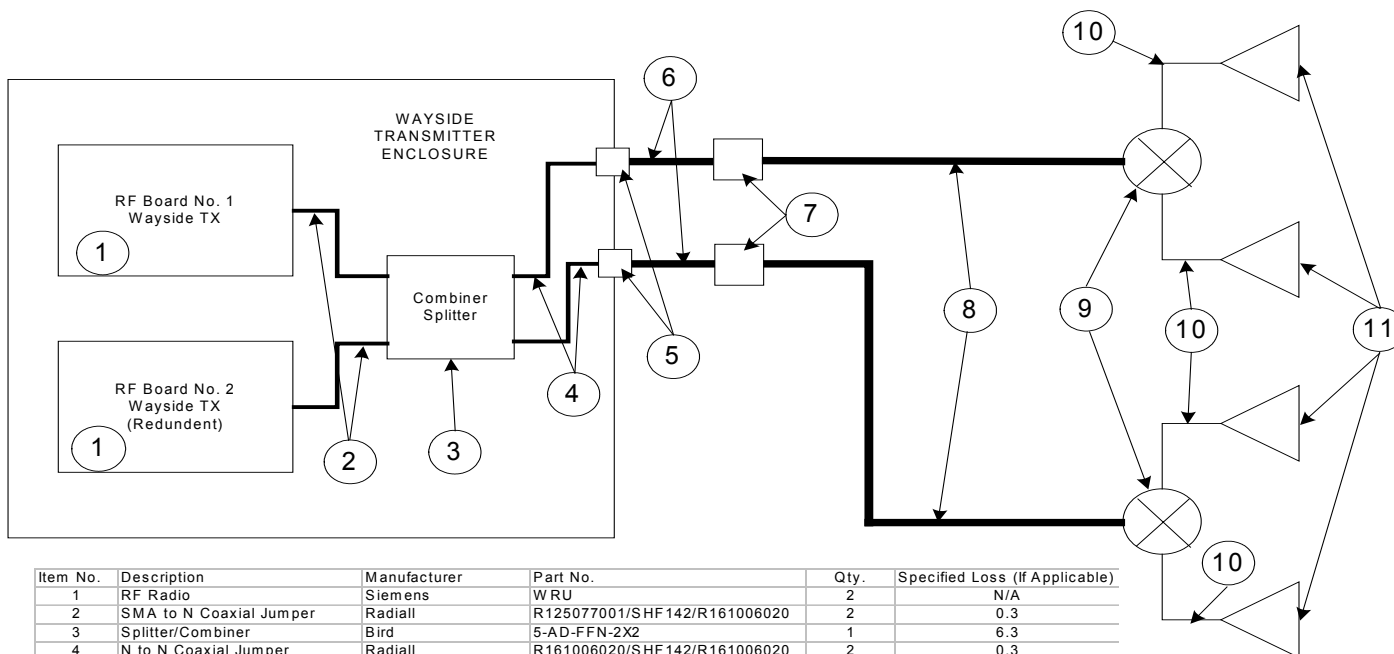

Item No.	Description	Manufacturer	Part No.	Qty.	Specified Loss (If Applicable)
1	RF Radio	Siemens	WRU	2	N/A
2	SMA to N Coaxial Jumper	Radiall	R125077001/SHF142/R161006020	2	0.3
3	Splitter/Combiner	Bird	5-AD-FFN-2X2	1	6.3
4	N to N Coaxial Jumper	Radiall	R161006020/SHF142/R161006020	2	0.3
5	N Female Bulkhead Connector	Radiall	R161 730 000	2	0.05
6	N to N Coaxial Cable (2 Feet)	Andrew	LDF4-50A	2	0.2
7	Lightning Protector	Radiall	R445Q00004	2	0.1
8	N to N Coaxial Cable (15 Feet)	Andrew	LDF4-50A	2	1.8
9	Power Splitter	Bird	2-AD-FFN-2	2	3.0
10	N to N Coaxial Jumper (3 Feet)	Times Microwave	LMR-240	4	N/A
11	Antenna	Cushcraft	PC-2415N	4	N/A
	OR				
11	Antenna	Astron	P-2409	4	N/A
	OR				
11	Antenna	Astron	P2406	4	N/A
Note:	Cable lengths are minimum		Total Loss to 1 Antenna (dB)		12.05



Réf. :
Trad.: --
Mémo :

Ed/Rév :00/02
Date : 01/28/2003

SIEMENS

DCS RF INSTALLATION INSTRUCTIONS

New York City Transit

8. ANNEX 2 – GENERAL CONFIGURATION 2 – PARTS LIST

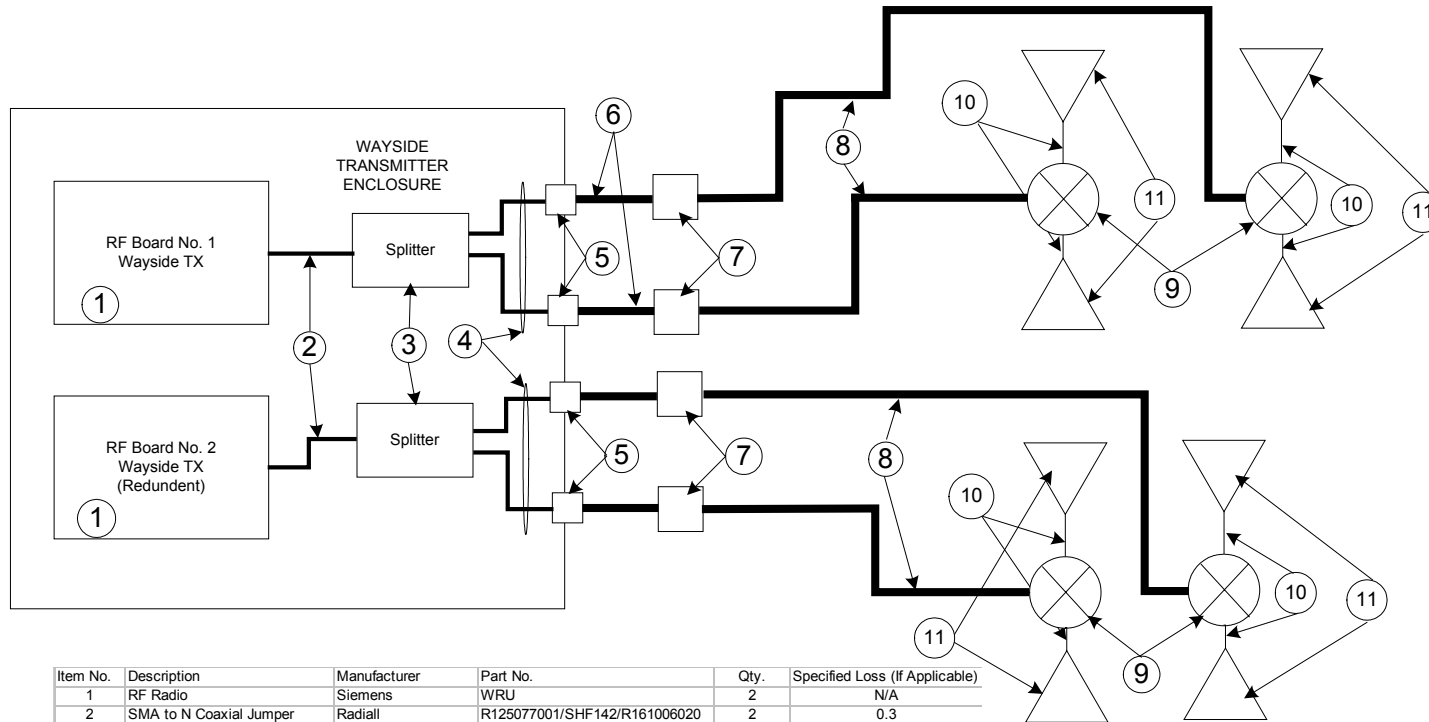

Item No.	Description	Manufacturer	Part No.	Qty.	Specified Loss (If Applicable)
1	RF Radio	Siemens	WRU	2	N/A
2	SMA to N Coaxial Jumper	Radiall	R125077001/SHF142/R161006020	2	0.3
3	Splitter/Combiner	Bird	2-AD-FFN-2	2	3.0
4	N to N Coaxial Jumper	Radiall	R161006020/SHF142/R161006020	4	0.3
5	N Female Bulkhead Connector	Radiall	R161 730 000	4	0.05
6	N to N Coaxial Cable (2 Feet)	Andrew	LDF4-50A	4	0.2
7	Lightning Protector	Radiall	R445Q00004	4	0.1
8	N to N Coaxial Cable (15 Feet)	Andrew	LDF4-50A	4	1.8
9	Power Splitter	Bird	2-AD-FFN-2	4	3.0
10	N to N Coaxial Jumper (3 Feet)	Times Microwave	LMR-240	8	N/A
11	Antenna	Cushcraft	PC-2415N	8	N/A
	OR				
11	Antenna	Astron	P-2409	8	N/A
	OR				
11	Antenna	Astron	P-2406	8	N/A
Note:	Cable lengths are minimum		Total Loss to 1 Antenna (dB)		8.75



Réf. :
 Trad.: --
 Mémo :

Ed/Rév :00/02
 Date : 01/28/2003

SIEMENS

DCS RF INSTALLATION INSTRUCTIONS

New York City Transit

9. ANNEX 3A: GENERAL CONFIGURATION 3A- PARTS LIST

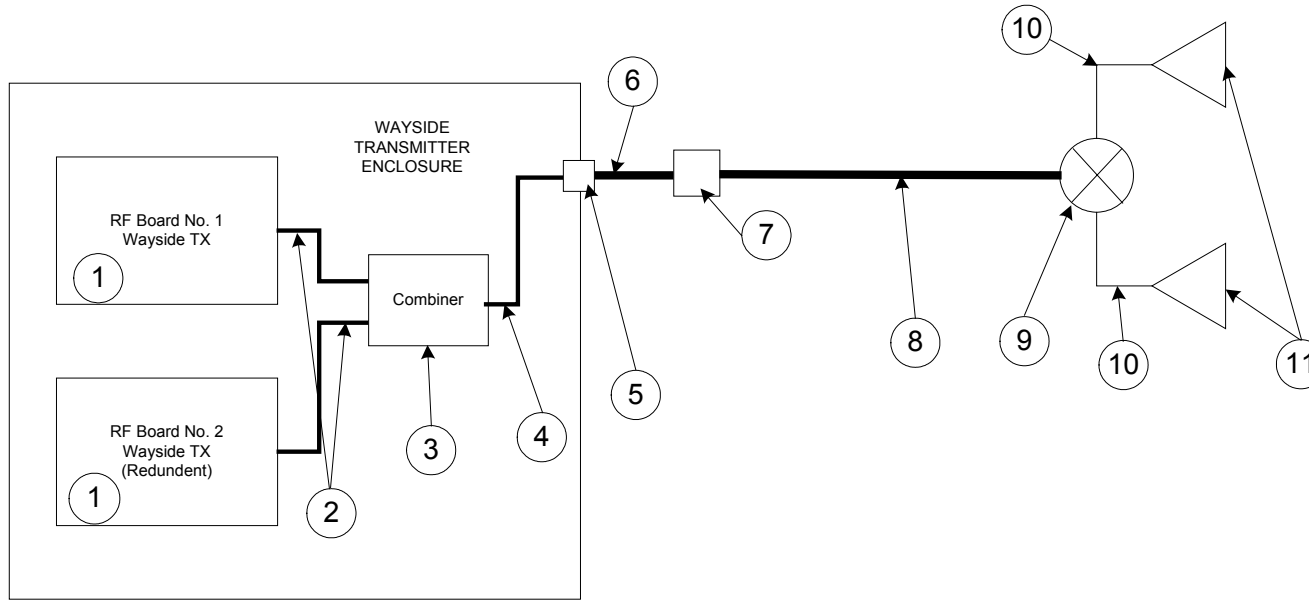

Item No.	Description	Manufacturer	Part No.	Qty.	Specified Loss (If Applicable)
1	RF Radio	Siemens	WRU	2	N/A
2	SMA to N Coaxial Jumper	Radiall	R125077001/SHF142/R161006020	2	0.3
3	Splitter/Combiner	Bird	2-AD-FFN-2	1	3.0
4	N to N Coaxial Jumper	Radiall	R161006020/SHF142/R161006020	1	0.3
5	N Female Bulkhead Connector	Radiall	R161 730 000	1	0.05
6	N to N Coaxial Cable (2 Feet)	Andrew	LDF4-50A	1	0.2
7	Lightning Protector	Radiall	R445Q00004	1	0.1
8	N to N Coaxial Cable (15 Feet)	Andrew	LDF4-50A	1	1.8
9	Power Splitter	Bird	2-AD-FFN-2	1	3.0
10	N to N Coaxial Jumper (3 Feet)	Times Microwave	LMR-240	2	N/A
11	Antenna	Cushcraft	PC-2415N	2	N/A
	OR				
11	Antenna	Astron	P-2409	2	N/A
	OR				
11	Antenna	Astron	P-2406	2	N/A
Note:	Cable lengths are minimum		Total Loss to 1 Antenna (dB)		8.75



Réf. :
 Trad.: --
 Mémo :

Ed/Rév :00/02
 Date : 01/28/2003

SIEMENS

DCS RF INSTALLATION INSTRUCTIONS

New York City Transit

10. ANNEX 3B: GENERAL CONFIGURATION 3B – PARTS LIST

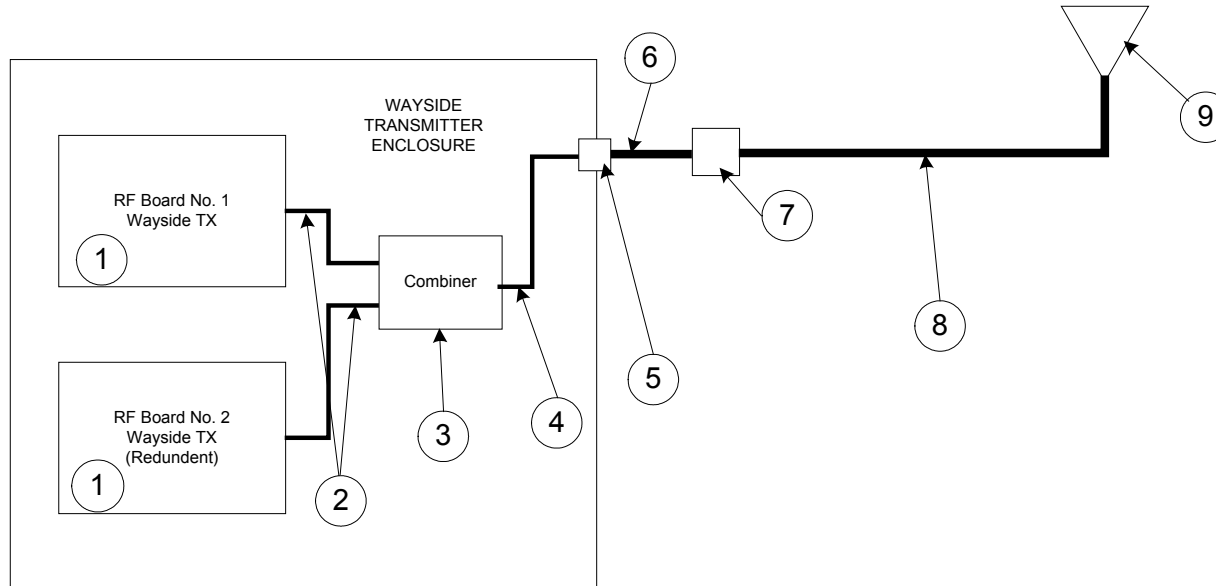

Item No.	Description	Manufacturer	Part No.	Qty.	Specified Loss (If Applicable)
1	RF Radio	Siemens	WRU	2	N/A
2	SMA to N Coaxial Jumper	Radiall	R125077001/SHF142/R161006020	2	0.3
3	Splitter/Combiner	Bird	2-AD-FFN-2	1	3.0
4	N to N Coaxial Jumper	Radiall	R161006020/SHF142/R161006020	2	0.3
5	N Female Bulkhead Connector	Radiall	R161 730 000	1	0.05
6	N to N Coaxial Cable (2 Feet)	Andrew	LDF4-50A	1	0.2
7	Lightning Protector	Radiall	R445Q00004	1	0.1
8	N to N Coaxial Cable (15 Feet)	Andrew	LDF4-50A	1	1.8
9	Antenna	Maxrad	MFB24006	1	N/A
	OR				
9	Antenna	Astron	P-2406	1	N/A
	OR				
9	Antenna	Astron	P-2409		N/A
	OR				
9	Antenna	Cushcraft	PC-2415N	1	N/A
Note:	Cable lengths are minimum		Total Loss to Antenna		5.75



Réf. :
 Trad.: --
 Mémo :

Ed/Rév :00/02
 Date : 01/28/2003



DCS RF INSTALLATION INSTRUCTIONS

New York City Transit

11. ANNEX 4A: GENERAL CONFIGURATION 4A – PARTS LIST

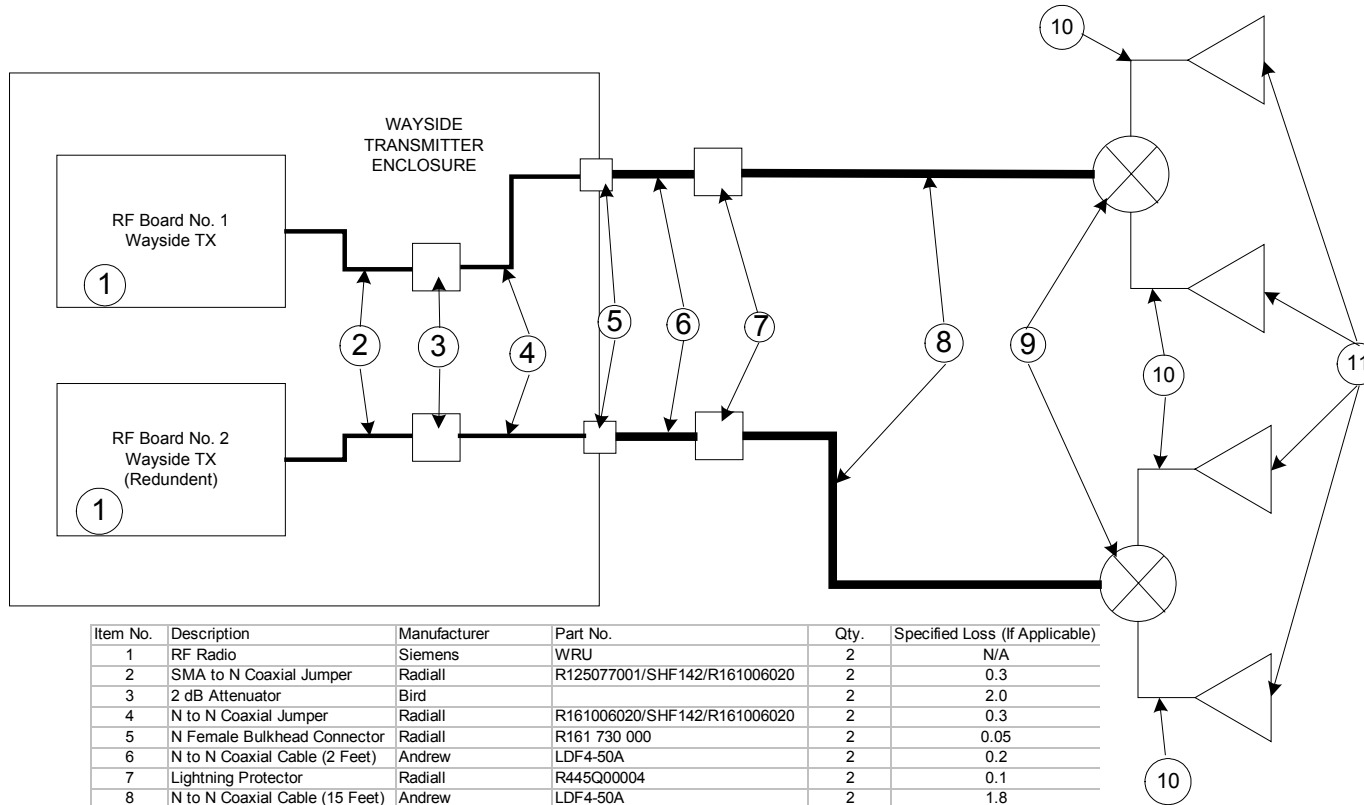

Item No.	Description	Manufacturer	Part No.	Qty.	Specified Loss (if Applicable)
1	RF Radio	Siemens	WRU	2	N/A
2	SMA to N Coaxial Jumper	Radiall	R125077001/SHF142/R161006020	2	0.3
3	2 dB Attenuator	Bird		2	2.0
4	N to N Coaxial Jumper	Radiall	R161006020/SHF142/R161006020	2	0.3
5	N Female Bulkhead Connector	Radiall	R161 730 000	2	0.05
6	N to N Coaxial Cable (2 Feet)	Andrew	LDF4-50A	2	0.2
7	Lightning Protector	Radiall	R445Q00004	2	0.1
8	N to N Coaxial Cable (15 Feet)	Andrew	LDF4-50A	2	1.8
9	Power Splitter	Bird	2-AD-FFN-2	2	3.0
10	N to N Coaxial Jumper (3 Feet)	Times Microwave	LMR-240	4	N/A
11	Antenna	Astron	P-2409	4	N/A
	OR				
11	Antenna	Astron	P-2406	4	N/A
	OR				
11	Antenna	Cushcraft	PC-2415N	4	N/A
Note:	Cable lengths are minimum		Total Loss to Antenna (dB)		7.75



Réf. :
Trad.: --
Mémo :

Ed/Rév :00/02
Date : 01/28/2003

SIEMENS

DCS RF INSTALLATION INSTRUCTIONS

New York City Transit

12. ANNEX 4B: GENERAL CONFIGURATION 4B – PARTS LIST

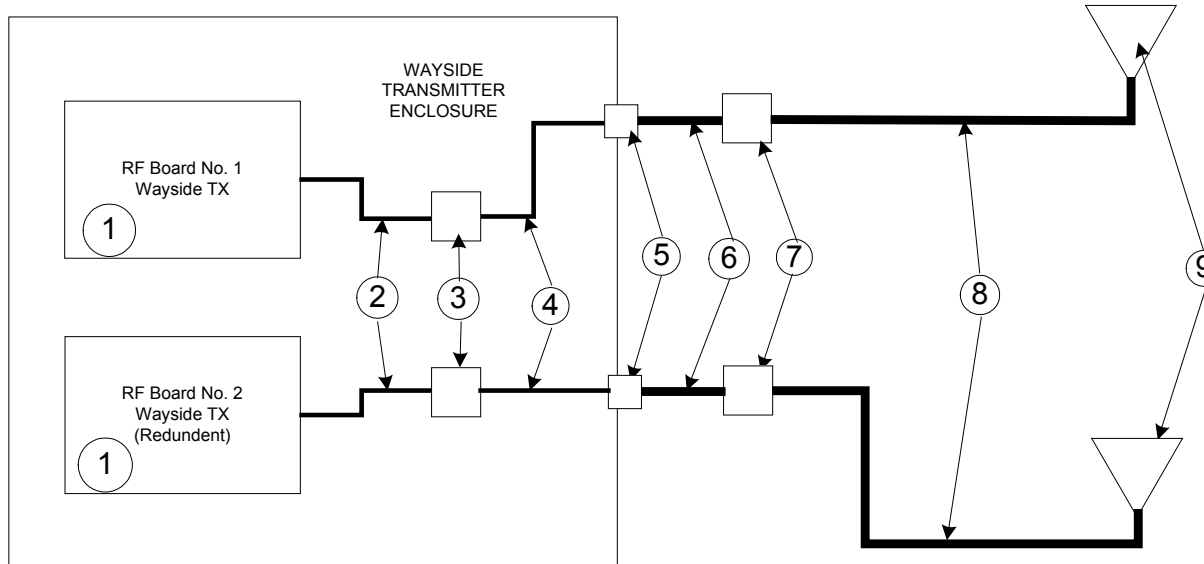

Item No.	Description	Manufacturer	Part No.	Qty.	Specified Loss (If Applicable)
1	RF Radio	Siemens	WRU	2	N/A
2	SMA to N Coaxial Jumper	Radiall	R125077001/SHF142/R161006020	2	0.3
3	2 dB Attenuator	Bird		2	2.0
4	N to N Coaxial Jumper	Radiall	R161006020/SHF142/R161006020	2	0.3
5	N Female Bulkhead Connector	Radiall	R161 730 000	2	0.05
6	N to N Coaxial Cable (2 Feet)	Andrew	LDF4-50A	2	0.2
7	Lightning Protector	Radiall	R445Q00004	2	0.1
8	N to N Coaxial Cable (15 Feet)	Andrew	LDF4-50A	2	1.8
9	Antenna	Astron	P-2409	2	N/A
	OR				
9	Antenna	Astron	P-2406	2	N/A
	OR				
9	Antenna	Maxrad	MFB24006	2	N/A
Note:	Cable lengths are minimum		Total Loss to Antenna (dB)		4.75



Réf. :
 Trad.: --
 Mémo :

Ed/Rév :00/02
 Date : 01/28/2003

SIEMENS

DCS RF INSTALLATION INSTRUCTIONS

New York City Transit

13. ANNEX 5A: GENERAL CONFIGURATION 5A – PARTS LIST

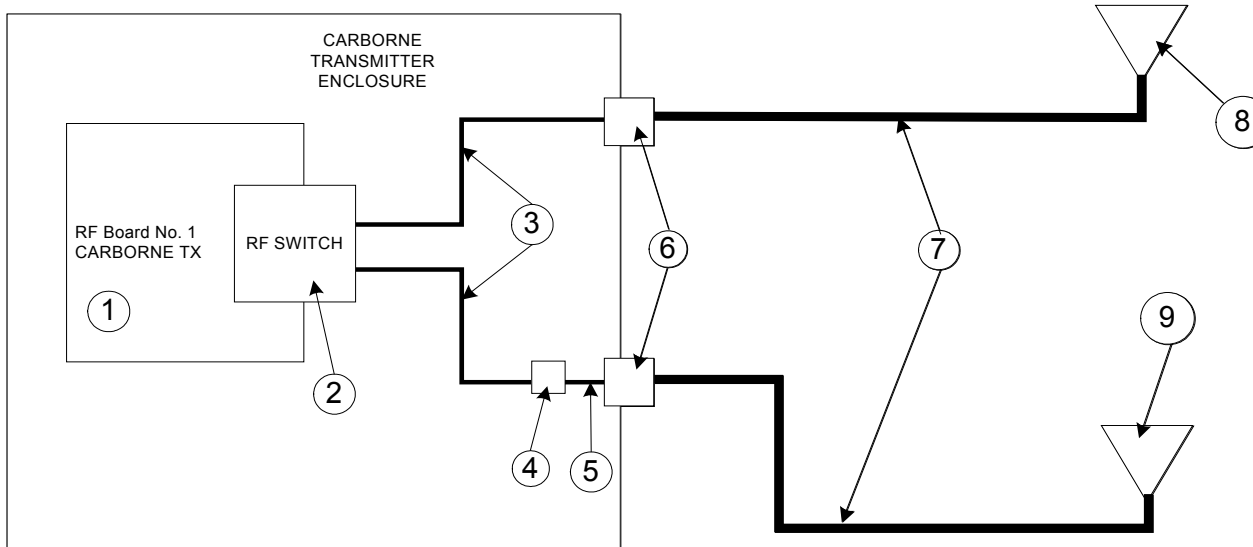

Item No.	Description	Manufacturer	Part No.	Qty.	Specified Loss Ant 1	Specified Loss Ant 2
1	RF Radio	Siemens	CRU	1	N/A	N/A
2	RF Switch (Part of RF Radio)	Siemens		1	0.5	0.5
3	SMA to N Coaxial Jumper			2	0.3	0.3
4	2 dB Attenuator	Times Microwave	LMR-240	3	N/A	2.0
5	N to N Coaxial Jumper (1 Feet)	Bird	2-A-MFN-02	1	0.0	0.1
6	Lightning Protector	Radiall	R445Q00004	2	0.1	0.1
7	N to N Coaxial Cable (15 Feet)	Times Microwave	LMR-240	2	1.5	1.5
8	Antenna 1	Radiall Larson	PA 4 14 2400	1	N/A	----
9	Antenna 2	Astron	P-2409	1	----	N/A
			Total Loss to Antenna (dB)		2.4	4.5



Réf. :
 Trad.: --
 Mémo :

Ed/Rév :00/02
 Date : 01/28/2003

SIEMENS

DCS RF INSTALLATION INSTRUCTIONS

New York City Transit

14. ANNEX 5B: GENERAL CONFIGURATION 5B – PARTS LIST

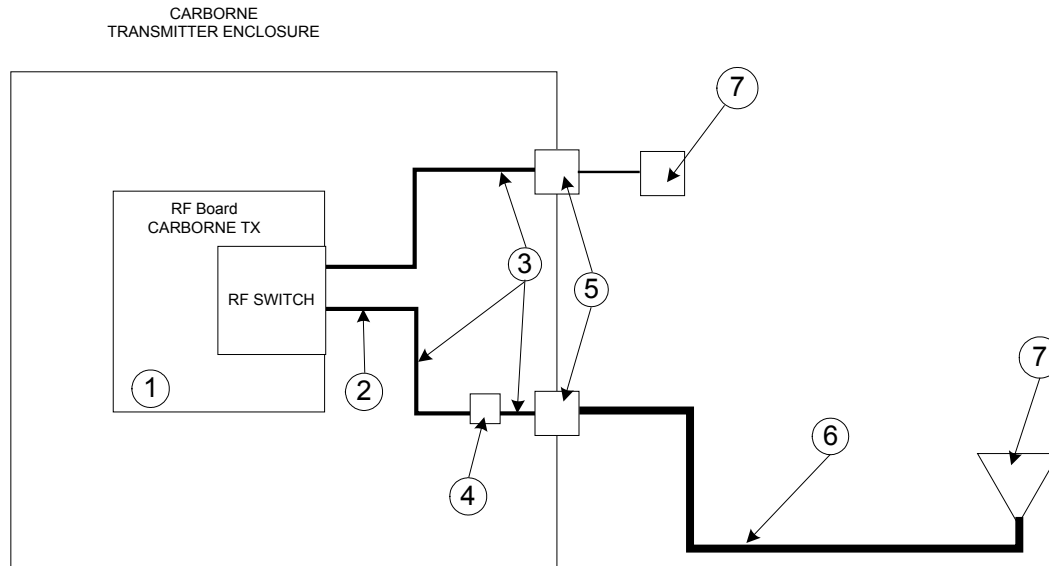

1	RF Radio w/RF Switch	Siemens	CRU	1	0.5
2	SMA to N Coaxial Jumper			1	0.1
3	N to N Coaxial Jumper (1 Feet)	Times Microwave	LMR-240	3	0.3
4	2 dB Attenuator	Bird	2-A-MFN-02	1	2.0
5	Lightning Protector	Radiall	R445Q00004	2	0.1
6	N to N Coaxial Cable (15 Feet)	Times Microwave	LMR-240	2	1.5
7	Antenna 1	Astron	P-2409	1	N/A
	OR				
7	Antenna 1		P-2406	1	N/A
8	50 Ohm Terminating Pad	Bird		1	N/A
Note:	Cable lengths are minimum		Total Loss to Antenna (dB)		4.5



New York City Transit

Réf. :
Trad.: --
Mémo :

DCS RF INSTALLATION INSTRUCTIONS

Ed/Rév :00/02

Date : 01/28/2003

SIEMENS

15.ANNEX A: ANTENNA CONFIGURATION A

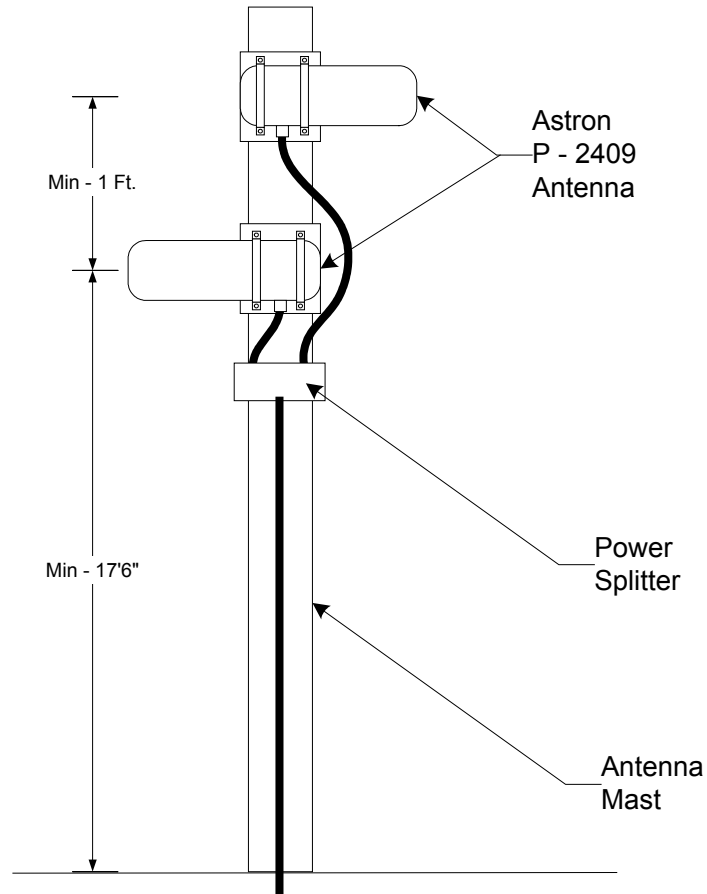

Antenna Orientation

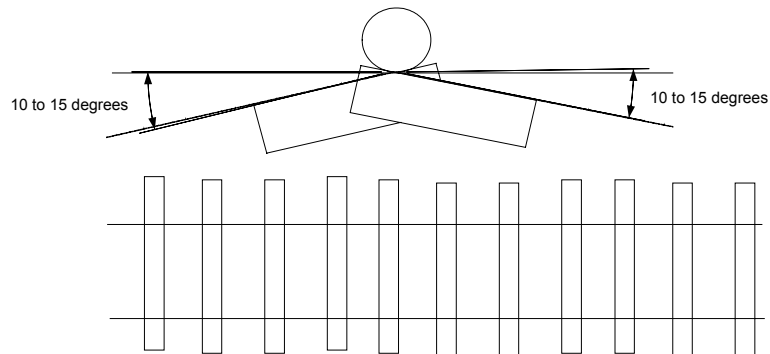



New York City Transit

Réf. :
Trad.: --
Mémo :

DCS RF INSTALLATION INSTRUCTIONS

Ed/Rév :00/02

Date : 01/28/2003

SIEMENS

16.ANNEX B: ANTENNA CONFIGURATION B

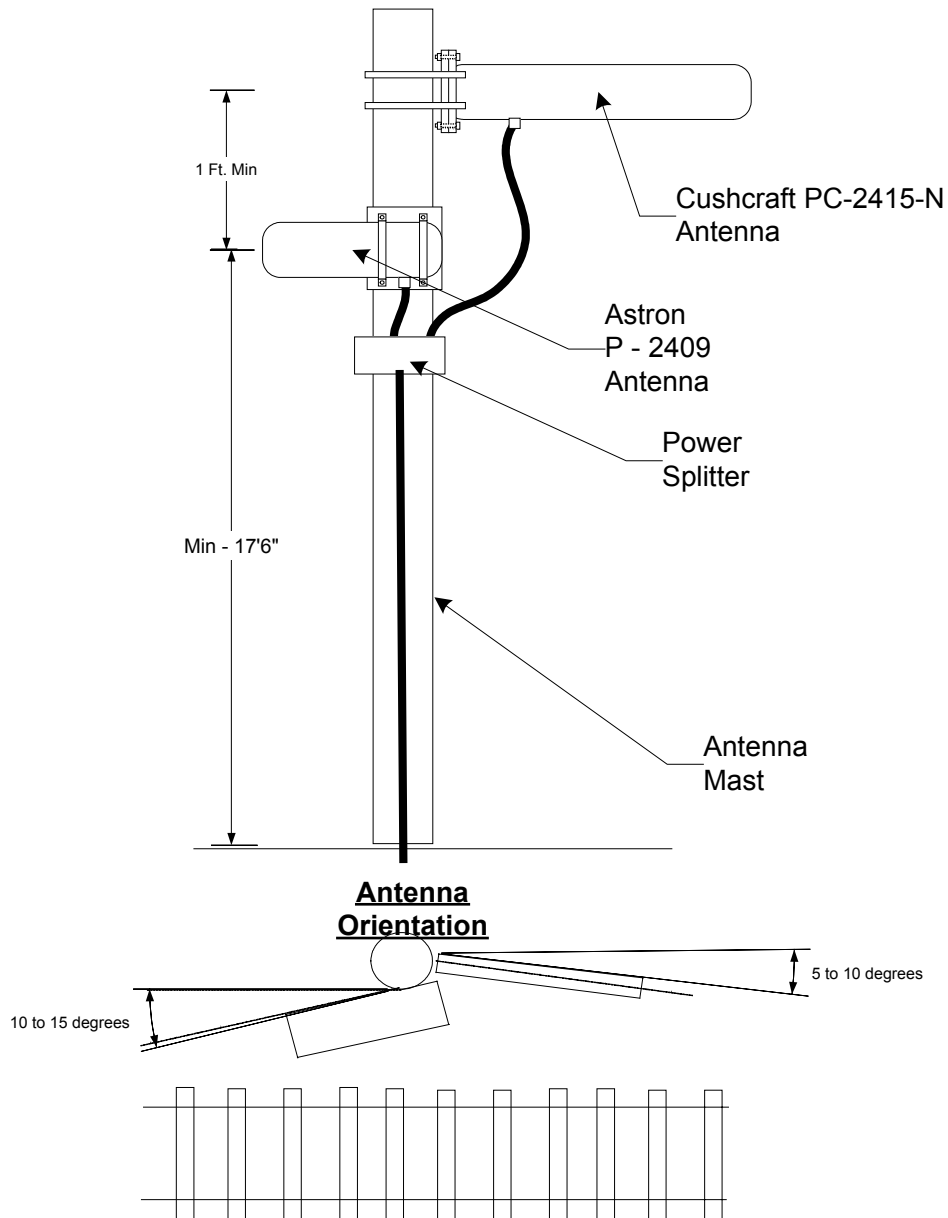



New York City Transit

Réf. :
Trad.: --
Mémo :

DCS RF INSTALLATION INSTRUCTIONS

Ed/Rév :00/02

Date : 01/28/2003

SIEMENS

17.ANNEX C: ANTENNA CONFIGURATION C

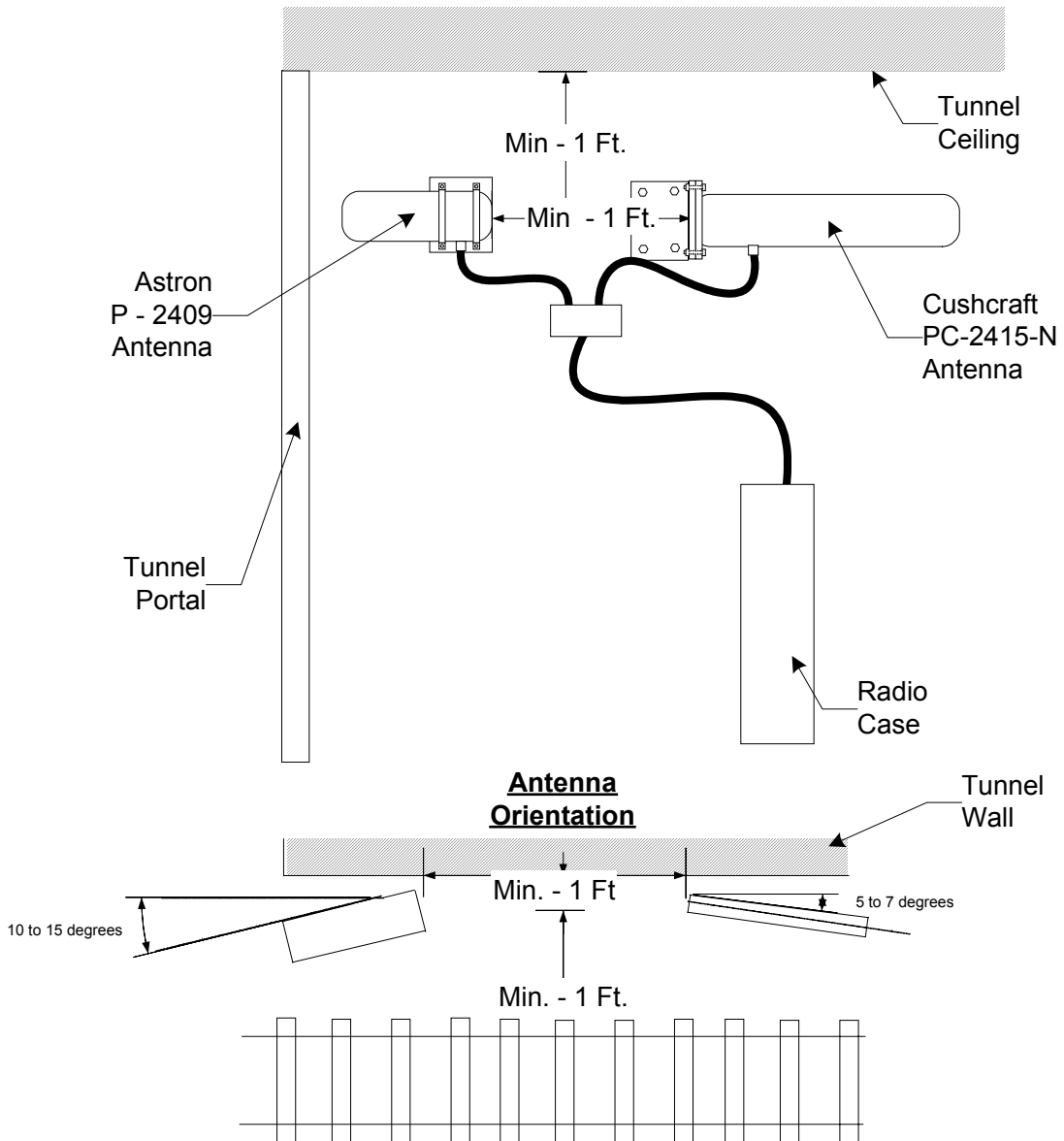



New York City Transit

Réf. :
Trad.: --
Mémo :

DCS RF INSTALLATION INSTRUCTIONS

Ed/Rév :00/02

Date : 01/28/2003

SIEMENS

18.ANNEX D: ANTENNA CONFIGURATION D

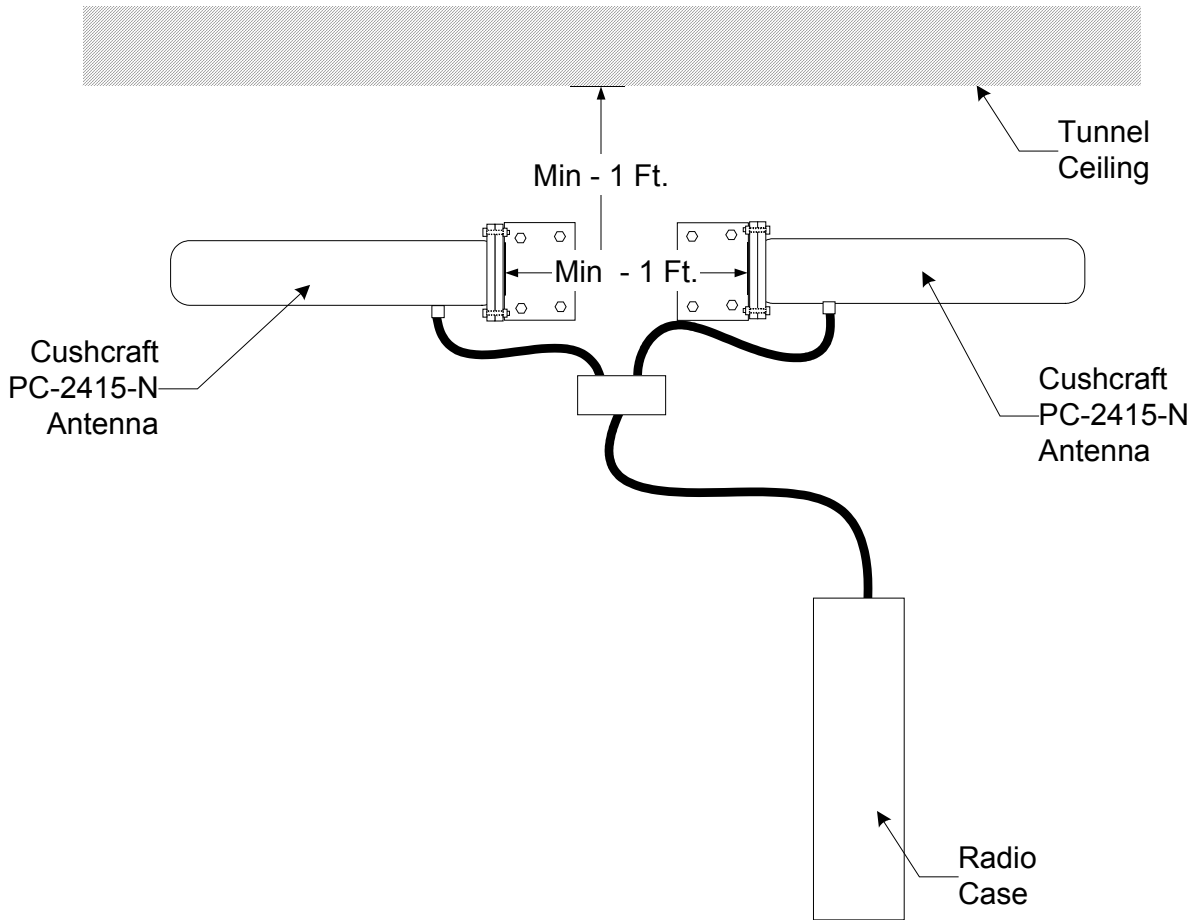

Antenna Orientation

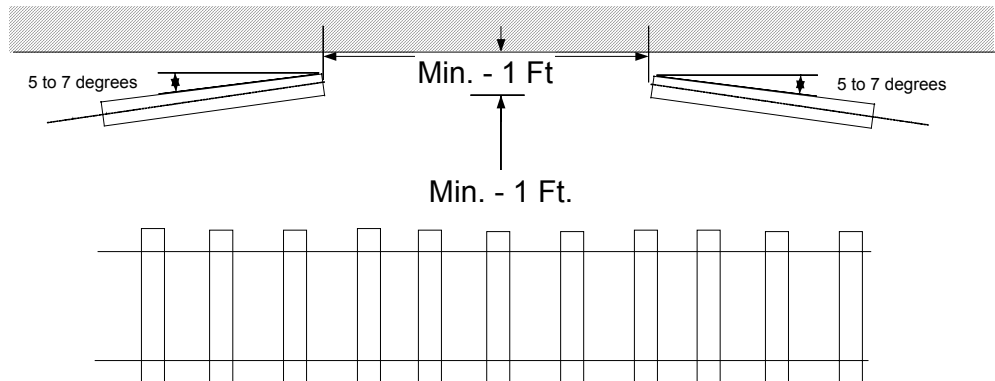



Réf. :
Trad.: --
Mémo :

Ed/Rév :00/02
Date : 01/28/2003

SIEMENS

DCS RF INSTALLATION INSTRUCTIONS

New York City Transit

19.ANEX TR: TEST RECORD

FCC Certification Compliance Checksheet - Wayside							
Location Number	Configuration Number	WRE unit	Minimum Configuration	Antenna Gain	Calculated Input Power	FCC Limit	Pass/Fail
1 - N	1 - 5(b) (from Ant Config Drawings)	Power, dBm	Cable/path Loss, dB Path loss WRE to ant	6, 9, 13.9	to Antenna, dBm Columns(C - D + E)	dBm	Cal <FCC (y/n) (See note 1)
1 - 1	1	a	5.1	13.9	a	36	
		b			b		
1 - 2	1	a	5.1	13.9	a	36	
		b			b		
1 - 3	1	a	5.1	13.9	a	36	
		b			b		
1 - 4	1	a	5.1	13.9	a	36	
		b			b		
1 - 5	1	a	5.1	13.9	a	36	
		b			b		
2 - 1	1	a	5.1	13.9	a	36	
		b			b		
2 - 2	1	a	5.1	13.9	a	36	
		b			b		
2 - 3	1	a	5.1	13.9	a	36	
		b			b		
2 - 4	1	a	5.1	13.9	a	36	
		b			b		
3 - 1 Q2	1	a	5.1	13.9	a	36	
		b			b		
3 - 2 Q2	1	a	5.1	13.9	a	36	
		b			b		
3 - 3 Q2	3A	a	5.1	13.9	a	36	



Réf. :
 Trad.: --
 Mémo :

Ed/Rév :00/02
 Date : 01/28/2003

SIEMENS

DCS RF INSTALLATION INSTRUCTIONS

New York City Transit

3 - 4 Q2	3A	a	5.1	13.9	a	36	
3 - 5 Q2	3A	a	5.1	13.9	a	36	
3 - 6 Q2	1	a b	5.1	13.9	a b	36	
3 - 3 Q1	3A	a	5.1	13.9	a	36	
3 - 4 Q1	3A	a	5.1	13.9	a	36	
3 - 5 Q1	3A	a	5.1	13.9	a	36	
4 - 1	1	a b	5.1	13.9	a b	36	
4 - 2	1	a b	5.1	13.9	a b	36	
4 - 3	1	a b	5.1	13.9	a b	36	
4 - 4	1	a b	5.1	13.9	a b	36	
5 - 1	1	a b	5.1	13.9	a b	36	
5 - 2	1	a b	5.1	13.9	a b	36	
5 - 3	1	a b	5.1	13.9	a b	36	
5 - 4	1	a b	5.1	13.9	a b	36	
5 - 5	1	a b	5.1	13.9	a b	36	
6 - 1	1	a b	5.1	13.9	a b	36	
6 - 2	1	a	5.1	13.9	a	36	



Réf. :
 Trad.: --
 Mémo :

Ed/Rév :00/02
 Date : 01/28/2003

SIEMENS

DCS RF INSTALLATION INSTRUCTIONS

New York City Transit

		b			b		
6 - 3	1	a	5.1	13.9	a	36	
		b			b		
6 - 4	1	a	5.1	13.9	a	36	
		b			b		
6 - 5	1	a	5.1	13.9	a	36	
		b			b		
6 - 6	1	a	5.1	13.9	a	36	
		b			b		
6 - 7	1	a	5.1	13.9	a	36	
		b			b		
7 - 1	1	a	5.1	13.9	a	36	
		b			b		
7 - 2	1	a	5.1	13.9	a	36	
		b			b		
7 - 3	1	a	5.1	13.9	a	36	
		b			b		
7 - 4	1	a	5.1	13.9	a	36	
		b			b		
7 - 5	1	a	5.1	13.9	a	36	
		b			b		
8 - 1	1	a	5.1	13.9	a	36	
		b			b		
8 - 2	1	a	5.1	13.9	a	36	
		b			b		
8 - 3	1	a	5.1	13.9	a	36	
		b			b		
9 - 1	1	a	5.1	13.9	a	36	
		b			b		
9 - 2	1	a	5.1	13.9	a	36	
		b			b		
9 - 3	1	a	5.1	13.9	a	36	
		b			b		



Réf. :
 Trad.: --
 Mémo :

Ed/Rév :00/02
 Date : 01/28/2003

SIEMENS

DCS RF INSTALLATION INSTRUCTIONS

New York City Transit

9 - 4	1	a	5.1	13.9	a	36	
		b			b		
9 - 5	1	a	5.1	13.9	a	36	
		b			b		
9 - 6	1	a	5.1	13.9	a	36	
		b			b		
9 - 7	1	a	5.1	13.9	a	36	
		b			b		
9 - 8	1	a	5.1	13.9	a	36	
		b			b		
10 - 1	1	a	5.1	13.9	a	36	
		b			b		
10 - 2	3A	a	5.1	9	a	36	
10 - 3	3A	a	5.1	9	a	36	
10 - 4	3A	a	5.1	9	a	36	
10 - 5	3A	a	5.1	9	a	36	
10 - 6	3A	a	5.1	9	a	36	
11 - 1	3A	a	5.1	13.9	a	36	
11 - 2	3A	a	5.1	13.9	a	36	
11 - 3	3A	a	5.1	13.9	a	36	
12 - 1	3A	a	5.1	13.9	a	36	
12 - 2	3A	a	5.1	13.9	a	36	
12 - 3	3A	a	5.1	13.9	a	36	



Réf. :
 Trad.: --
 Mémo :

Ed/Rév :00/02
 Date : 01/28/2003

SIEMENS

DCS RF INSTALLATION INSTRUCTIONS

New York City Transit

12 - 4	3A	a	5.1	13.9	a	36	
13 - 1	3A	a	5.1	13.9	a	36	
13 - 2	3A	a	5.1	13.9	a	36	
13 - 3	3A	a	5.1	13.9	a	36	
13 - 4	3A	a	5.1	13.9	a	36	
14 - 1	3A	a	5.1	9	a	36	
14 - 2	3B	a	2.1	6	a	36	
14 - 3	3A	a	5.1	9	a	36	
J-1-1	3A	a	5.1	9	a	36	
J-1-2	3A	a	5.1	9	a	36	

Note 1: FCC limit must be higher than Calculated value. If not insert attenuation in 1 dB steps at WRU output to lower the RF power output. In Column C, a and b refer to the type N output connectors on each transmitter case as applicable. Calculated value for a and b must comply.

Note 2: The above table is provided as an example for this specific Canarsie installation and is preliminary. For other applications, the table will be modified for the specific layout and will be made available.



Réf. :
 Trad.: --
 Mémo :

Ed/Rév :00/02
 Date : 01/28/2003

SIEMENS

DCS RF INSTALLATION INSTRUCTIONS

New York City Transit

FCC Certification Compliance Checksheet - Carborne

Train Number	Configuration Number	CRE Output	Minimum Configuration	Antenna Gain	Calculated/Measured Input	FCC Limit	Pass/Fail
N	1 - 5(b) (from Ant Config Drawings)	Or Ant Input Power, dBm	Cable Loss, dB Use only if CRE Meas	6, 9, 13.9 or 14	Power to Antenna, dBm (See note 2)	dBm	Cal <FCC (y/n) (See note 1)
1A	5A	a	1.6	14	a	36	
		b			b		
1B	5B	a	1.6	9	a	36	
2A	5A	a	1.6	14	a	36	
		b			b		
2B	5B	a	1.6	9	a	36	
3A	5A	a	1.6	14	a	36	
		b			b		
3B	5B	a	1.6	9	a	36	
4A	5A	a	1.6	14	a	36	
		b			b		
4B	5B	a	1.6	9	a	36	
5A	5A	a	1.6	14	a	36	
		b			b		
5B	5B	a	1.6	9	a	36	
6A	5A	a	1.6	14	a	36	
		b			b		
6B	5B	a	1.6	9	a	36	
7A	5A	a	1.6	14	a	36	
		b			b		
7B	5B	a	1.6	9	a	36	



Réf. :
 Trad.: --
 Mémo :

Ed/Rév :00/02
 Date : 01/28/2003

SIEMENS

DCS RF INSTALLATION INSTRUCTIONS

New York City Transit

8A	5A	a	1.6	14	a	36	
		b			b		
8B	5B	a	1.6	9	a	36	
9A	5A	a	1.6	14	a	36	
		b			b		
9B	5B	a	1.6	9	a	36	
10A	5A	a	1.6	14	a	36	
		b			b		
10B	5B	a	1.6	9	a	36	
11A	5A	a	1.6	14	a	36	
		b			b		
11B	5B	a	1.6	9	a	36	
12A	5A	a	1.6	14	a	36	
		b			b		
12B	5B	a	1.6	9	a	36	
13A	5A	a	1.6	14	a	36	
		b			b		
13B	5B	a	1.6	9	a	36	
14A	5A	a	1.6	14	a	36	
		b			b		
14B	5B	a	1.6	9	a	36	
15A	5A	a	1.6	13.9	a	36	
		b			b		
15B	5B	a	1.6	13.9	a	36	
16A	5A	a	1.6	13.9	a	36	



Réf. :
 Trad.: --
 Mémo :

Ed/Rév :00/02
 Date : 01/28/2003

SIEMENS

DCS RF INSTALLATION INSTRUCTIONS

New York City Transit

16B	5B	b	1.6	13.9	b	36	
		a			a		
17A	5A	a	1.6	13.9	a	36	
		b			b		
17B	5B	a	1.6	13.9	a	36	
18A	5A	a	1.6	14	a	36	
		b			b		
18B	5B	a	1.6	9	a	36	
19A	5A	a	1.6	14	a	36	
		b			b		
19B	5B	a	1.6	9	a	36	
20A	5A	a	1.6	14	a	36	
		b			b		
20B	5B	a	1.6	9	a	36	
21A	5A	a	1.6	14	a	36	
		b			b		
21B	5B	a	1.6	9	a	36	
22A	5A	a	1.6	14	a	36	
		b			b		
22B	5B	a	1.6	9	a	36	
23A	5A	a	1.6	14	a	36	
		b			b		
23B	5B	a	1.6	9	a	36	
24A	5A	a	1.6	14	a	36	
		b			b		



Réf. :
 Trad.: --
 Mémo :

Ed/Rév :00/02
 Date : 01/28/2003

SIEMENS

DCS RF INSTALLATION INSTRUCTIONS

New York City Transit

24B	5B	a	1.6	9	a	36	
25A	5A	a	1.6	14	a	36	
		b			b		
25B	5B	a	1.6	9	a	36	
26A	5A	a	1.6	14	a	36	
		b			b		
26B	5B	a	1.6	9	a	36	
27A	5A	a	1.6	14	a	36	
		b			b		
27B	5B	a	1.6	9	a	36	
28A	5A	a	1.6	14	a	36	
		b			b		
28B	5B	a	1.6	9	a	36	
29A	5A	a	1.6	14	a	36	
		b			b		
29B	5B	a	1.6	9	a	36	
30A	5A	a	1.6	14	a	36	
		b			b		
30B	5B	a	1.6	9	a	36	
31A	5A	a	1.6	14	a	36	
		b			b		
31B	5B	a	1.6	9	a	36	
32A	5A	a	1.6	14	a	36	
		b			b		
32B	5B	a	1.6	9	a	36	



Réf. :
 Trad.: --
 Mémo :

Ed/Rév :00/02
 Date : 01/28/2003

SIEMENS

DCS RF INSTALLATION INSTRUCTIONS

New York City Transit

33A	5A	a	1.6	14	a	36	
		b			b		
33B	5B	a	1.6	9	a	36	
34A	5A	a	1.6	14	a	36	
		b			b		
34B	5B	a	1.6	9	a	36	
35A	5A	a	1.6	14	a	36	
		b			b		
35B	5B	a	1.6	9	a	36	
36A	5A	a	1.6	14	a	36	
		b			b		
36B	5B	a	1.6	9	a	36	
37A	5A	a	1.6	14	a	36	
		b			b		
37B	5B	a	1.6	9	a	36	
38A	5A	a	1.6	14	a	36	
		b			b		
38B	5B	a	1.6	9	a	36	
39A	5A	a	1.6	14	a	36	
		b			b		
39B	5B	a	1.6	9	a	36	
40A	5A	a	1.6	14	a	36	
		b			b		
40B	5B	a	1.6	9	a	36	



Réf. :
 Trad.: --
 Mémo :

Ed/Rév :00/02
 Date : 01/28/2003

SIEMENS

DCS RF INSTALLATION INSTRUCTIONS

New York City Transit

41A	5A	a	1.6	14	a	36	
		b			b		
41B	5B	a	1.6	9	a	36	
42A	5A	a	1.6	14	a	36	
		b			b		
42B	5B	a	1.6	9	a	36	
43A	5A	a	1.6	14	a	36	
		b			b		
43B	5B	a	1.6	9	a	36	
44A	5A	a	1.6	14	a	36	
		b			b		
44B	5B	a	1.6	9	a	36	
45A	5A	a	1.6	14	a	36	
		b			b		
45B	5B	a	1.6	9	a	36	
46A	5A	a	1.6	14	a	36	
		b			b		
46B	5B	a	1.6	9	a	36	
47A	5A	a	1.6	14	a	36	
		b			b		
47B	5B	a	1.6	9	a	36	
48A	5A	a	1.6	14	a	36	
		b			b		
48B	5B	a	1.6	9	a	36	
49A	5A	a	1.6	14	a	36	



Réf. :
 Trad.: --
 Mémo :

Ed/Rév :00/02
 Date : 01/28/2003

SIEMENS

DCS RF INSTALLATION INSTRUCTIONS

New York City Transit

		b			b		
49B	5B	a	1.6	9	a	36	
50A	5A	a	1.6	14	a	36	
		b			b		
50B	5B	a	1.6	9	a	36	
51A	5A	a	1.6	14	a	36	
		b			b		
51B	5B	a	1.6	9	a	36	
52A	5A	a	1.6	14	a	36	
		b			b		
52B	5B	a	1.6	9	a	36	
53A	5A	a	1.6	14	a	36	
		b			b		
53B	5B	a	1.6	9	a	36	

Note 1: FCC limit must be higher than Calculated/measured value. If not insert attenuation in 1 dB steps at CTU output to lower the RF power output. If power output measurements are made at the CRE output, compliance must be determined by calculating power levels for both a and b outputs. If power output measurements are made at the antenna input port, this measured value is listed in Column C and then compared directly to the FCC limit.

Note 2: If power output of the CRE is measured, subtract the specified path loss in dB to determine to available input power to the antenna.

Note 3: The above table is provided as an example for this specific Canarsie installation and is preliminary. For other applications, the table will be modified for the specific layout and will be made available.



New York City Transit

Réf. :
Trad.: --
Mémo :

DCS RF INSTALLATION INSTRUCTIONS

Ed/Rév :00/02

Date : 01/28/2003

SIEMENS

Wayside Antenna Power levels:

Location:		Date:
Test Technician:		
Antenna (N or S)	RF Power Measurement at 100 Ft.	RF Power Measurement at 300 Ft.
1N		
2N		
3N		
4N		
1S		
2S		
3S		
4S		



New York City Transit

Réf. :
Trad.: --
Mémo :

DCS RF INSTALLATION INSTRUCTIONS

Ed/Rév :00/02

Date : 01/28/2003

SIEMENS

Carborne Antenna Power levels:

Train ID:		Date:
Test Technician:		
Antenna (N or S)	RF Power Measurement at 50 Ft.	Notes:
1		
2		



New York City Transit

Réf. :
Trad.: --
Mémo :

Ed/Rév :00/02

Date : 01/28/2003

DCS RF INSTALLATION INSTRUCTIONS

SIEMENS

END OF DOCUMENT