

**Serial Number**

**6.8L  
70kW  
Models**

**STANDBY GENERATOR  
OWNER'S MANUAL**

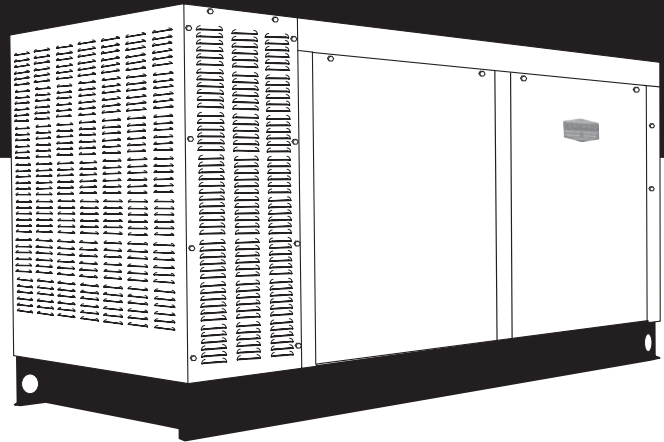

*A new standard of reliability*

**SIEMENS**

⚠ Not intended for use in critical life support applications. ⚠

— ⚠ **CAUTION** ⚠ —

**ONLY QUALIFIED ELECTRICIANS OR CONTRACTORS SHOULD ATTEMPT INSTALLATION!  
DEADLY EXHAUST FUMES. OUTDOOR INSTALLATION ONLY!**

This manual should remain with the unit.

| <b>SECTION</b>   | <b>PAGE</b> |
|--|-------------|
| <b>SAFETY RULES</b> .....  | <b>1-1</b>  |
| <b>INTRODUCTION</b> .....  | <b>1-3</b>  |
| Read this Manual Thoroughly .....  | 1-3         |
| Operation and Maintenance .....  | 1-3         |
| How to Obtain Service .....  | 1-3         |
| <b>IDENTIFICATION RECORD</b> .....   | <b>2-1</b>  |
| Data Label .....   | 2-1         |
| <b>EQUIPMENT DESCRIPTION</b> .....   | <b>3-1</b>  |
| Equipment Description .....  | 3-1         |
| Engine Oil Recommendations .....   | 3-1         |
| Coolant Recommendations .....  | 3-1         |
| <b>ENGINE PROTECTIVE DEVICES</b> .....   | <b>4-1</b>  |
| Coolant Temperature Sensing .....  | 4-1         |
| Low Coolant Level .....  | 4-1         |
| Oil Pressure Sensing .....   | 4-1         |
| Overcrank Shutdown .....   | 4-1         |
| Overspeed Shutdown .....   | 4-1         |
| RPM Sensor Loss Shutdown .....   | 4-1         |
| DC Fuse .....  | 4-1         |
| <b>FUEL SYSTEMS</b> .....  | <b>5-1</b>  |
| Fuel Requirements .....  | 5-1         |
| Natural Gas Fuel System .....  | 5-1         |
| Propane Vapor Withdrawal Fuel System .....   | 5-1         |
| LP Fuel System .....   | 5-1         |
| <b>SPECIFICATIONS</b> .....  | <b>6-1</b>  |
| Generator .....  | 6-1         |
| Engine .....   | 6-1         |
| Cooling System .....   | 6-1         |
| Fuel System .....  | 6-1         |
| Electrical System .....  | 6-1         |
| Cold Weather Kit .....   | 6-2         |
| 5.4L & 6.8L Ignition Description .....   | 6-3         |
| Ignition Power-up Input ("56 Line Input") .....                                    | 6-3         |
| Ignition Enable ("14 Line Input") .....  | 6-3         |
| Ignition Shutdown on Loss of Crank<br>or CAM Signals .....                         | 6-3         |
| Diagnostic Blink Patterns (Red LED Located<br>on the Ignition Control Board) ..... | 6-3         |
| <b>GENERAL INFORMATION</b> .....   | <b>7-1</b>  |
| Generator AC Lead Connections .....  | 7-1         |
| Four-lead, Single-phase Stator .....   | 7-1         |
| Alternator Power Winding Connections .....   | 7-1         |
| 3-phase Alternators .....  | 7-1         |
| <b>INSTALLATION</b> .....  | <b>8-1</b>  |
| Installation .....   | 8-1         |
| Preparation Before Start-up .....  | 8-1         |
| Transfer Switch .....  | 8-1         |
| Fuel System .....  | 8-1         |
| Generator Set Lubrication .....  | 8-1         |
| Prior to Initial Start-up .....  | 8-1         |
| Initial Inspection for QT Genset Start-up .....                                    | 8-2         |
| Start-up Inspection .....  | 8-2         |
| <b>OPERATION</b> .....   | <b>9-1</b>  |
| Generator Control and Operation .....  | 9-1         |
| Operating Unit with Automatic Transfer Switch .....                                | 9-1         |
| Operating Unit with Manual Transfer Switch .....                                   | 9-1         |
| Engine Start-up and Transfer .....   | 9-1         |
| Retransfer and Shutdown .....  | 9-1         |
| <b>MAINTENANCE</b> .....   | <b>10-1</b> |
| Maintenance Performed by Authorized<br>Service Facilities .....                    | 10-1        |
| Cooling System .....   | 10-1        |
| Checking Fluid Levels .....  | 10-1        |
| Check Engine Oil .....   | 10-1        |
| Battery Fluid .....  | 10-1        |
| Engine Coolant .....   | 10-2        |
| Maintenance Owner/Operator Can Perform .....                                       | 10-2        |
| Check Engine Oil Level .....   | 10-2        |
| Check Battery .....  | 10-2        |
| Exercise System .....  | 10-2        |
| Inspect Cooling System .....   | 10-2        |
| Check Engine Coolant Level .....   | 10-2        |
| Perform Visual Inspection .....  | 10-2        |
| Inspect Exhaust System .....   | 10-2        |
| Check Fan Belt .....   | 10-2        |
| Inspect Engine Governor .....  | 10-2        |
| Changing Engine Oil .....  | 10-2        |
| Changing the Engine Air Cleaner .....  | 10-3        |
| Spark Plugs .....  | 10-3        |
| Coolant Change .....   | 10-3        |
| Miscellaneous Maintenance .....  | 10-3        |
| Cleaning the Generator .....   | 10-3        |
| Battery .....  | 10-4        |
| Battery Maintenance .....  | 10-4        |
| Battery Replacement .....  | 10-4        |
| <b>SERVICE SCHEDULE</b> .....  | <b>11-1</b> |
| 30 kW - 150 kW Standby Gas Engine<br>Driven Generator Sets .....                   | 11-1        |
| <b>TROUBLESHOOTING</b> .....   | <b>12-1</b> |
| Troubleshooting Guide .....  | 12-1        |
| <b>NOTES</b>   |             |
| <b>EXPLODED VIEWS &amp; PARTS LISTS</b>  |             |
| <b>WIRING DIAGRAMS &amp; SCHEMATICS</b>  |             |
| <b>WARRANTY</b>  |             |



## Standby Generator Sets Important Safety Instructions



**⚠ SAVE THESE INSTRUCTIONS** – *The manufacturer suggests that these rules for safe operation be copied and posted in potential hazard areas. Safety should be stressed to all operators, potential operators, and service and repair technicians for this equipment.* **⚠**



### WARNING:



**The engine exhaust from this product contains chemicals known to the state of California to cause cancer, birth defects or other reproductive harm.**



### WARNING:



**This product contains or emits chemicals known to the state of California to cause cancer, birth defects or other reproductive harm.**

Study these SAFETY RULES carefully before installing, operating or servicing this equipment. Become familiar with this Owner's Manual and with the unit. The generator can operate safely, efficiently and reliably only if it is properly installed, operated and maintained. Many accidents are caused by failing to follow simple and fundamental rules or precautions.

The manufacturer cannot anticipate every possible circumstance that might involve a hazard. The warnings in this manual, and on tags and decals affixed to the unit are, therefore, not all inclusive. If a procedure, work method or operating technique is used that the manufacturer does not specifically recommend, ensure that it is safe for others. Also make sure the procedure, work method or operating technique utilized does not render the generator unsafe.

### ⚠ DANGER ⚠

- ⚠** Despite the safe design of this generator, operating this equipment imprudently, neglecting its maintenance or being careless can cause possible injury or death. Permit only responsible and capable persons to install, operate or maintain this equipment.
- ⚠** Potentially lethal voltages are generated by these machines. Ensure all steps are taken to render the machine safe before attempting to work on the generator.
- ⚠** Parts of the generator are rotating and/or hot during operation. Exercise care near running generators.

### ⚠ GENERAL HAZARDS ⚠

- For safety reasons, the manufacturer recommends that this equipment be installed, serviced and repaired by an Authorized Service Dealer or other competent, qualified electrician or installation technician who is familiar with applicable codes, standards and regulations. The operator also must comply with all such codes, standards and regulations.
- Installation, operation, servicing and repair of this (and related) equipment must always comply with applicable codes, standards, laws and regulations. Adhere strictly to local, state and national electrical and building codes. Comply with regulations the Occupational Safety and Health Administration (OSHA) has established. Also, ensure that the generator is installed, operated and serviced in accordance with the manufacturer's instructions and recommendations. Following installation, do nothing that might render the unit unsafe or in noncompliance with the aforementioned codes, standards, laws and regulations.
- The engine exhaust fumes contain carbon monoxide gas, which can be DEADLY. This dangerous gas, if breathed in sufficient concentrations, can cause unconsciousness or even death. For that reason, adequate ventilation must be provided. Exhaust gases must be piped safely away from any building or enclosure that houses the generator to an area where people, animals, etc., will not be harmed. This exhaust system must be installed properly, in strict compliance with applicable codes and standards.
- Keep hands, feet, clothing, etc., away from drive belts, fans, and other moving or hot parts. Never remove any drive belt or fan guard while the unit is operating.
- Adequate, unobstructed flow of cooling and ventilating air is critical in any room or building housing the generator to prevent buildup of explosive gases and to ensure correct generator operation. Do not alter the installation or permit even partial blockage of ventilation provisions, as this can seriously affect safe operation of the generator.
- Keep the area around the generator clean and uncluttered. Remove any materials that could become hazardous.
- When working on this equipment, remain alert at all times. Never work on the equipment when physically or mentally fatigued.
- Inspect the generator regularly, and promptly repair or replace all worn, damaged or defective parts using only factory-approved parts.



## Standby Generator Sets Important Safety Instructions



- Before performing any maintenance on the generator, disconnect its battery cables to prevent accidental start-up. Disconnect the cable from the battery post indicated by a NEGATIVE, NEG or (-) first. Reconnect that cable last.
- Never use the generator or any of its parts as a step. Stepping on the unit can stress and break parts, and may result in dangerous operating conditions from leaking exhaust gases, fuel leakage, oil leakage, etc.

### **ELECTRICAL HAZARDS**

- All generators covered by this manual produce dangerous electrical voltages and can cause fatal electrical shock. Utility power delivers extremely high and dangerous voltages to the transfer switch as well as the standby generator. Avoid contact with bare wires, terminals, connections, etc., on the generator as well as the transfer switch, if applicable. Ensure all appropriate covers, guards and barriers are in place before operating the generator. If work must be done around an operating unit, stand on an insulated, dry surface to reduce shock hazard.
- Do not handle any kind of electrical device while standing in water, while barefoot, or while hands or feet are wet. DANGEROUS ELECTRICAL SHOCK MAY RESULT.
- If personnel must stand on metal or concrete while installing, operating, servicing, adjusting or repairing this equipment, place insulative mats over a dry wooden platform. Work on the equipment only while standing on such insulative mats.
- The National Electrical Code (NEC) requires the frame and external electrically conductive parts of the generator to be connected to an approved earth ground. This grounding will help prevent dangerous electrical shock that might be caused by a ground fault condition in the generator set or by static electricity. Never disconnect the ground wire.
- Wire gauge sizes of electrical wiring, cables and cord sets must be adequate to handle the maximum electrical current (ampacity) to which they will be subjected.
- Before installing or servicing this (and related) equipment, make sure that all power voltage supplies are positively turned off at their source. Failure to do so will result in hazardous and possibly fatal electrical shock.
- Connecting this unit to an electrical system normally supplied by an electric utility shall be by means of a transfer switch so as to isolate the generator electric system from the electric utility distribution system when the generator is operating. Failure to isolate the two electric system power sources from each other by such means will result in damage to the generator and may also result in injury or death to utility power workers due to backfeed of electrical energy.

- Generators installed with an automatic transfer switch will crank and start automatically when normal (utility) source voltage is removed or is below an acceptable preset level. To prevent such automatic start-up and possible injury to personnel, disable the generator's automatic start circuit (battery cables, etc.) before working on or around the unit. Then, place a "Do Not Operate" tag on the generator control panel and on the transfer switch.
- In case of accident caused by electric shock, immediately shut down the source of electrical power. If this is not possible, attempt to free the victim from the live conductor. AVOID DIRECT CONTACT WITH THE VICTIM. Use a nonconducting implement, such as a dry rope or board, to free the victim from the live conductor. If the victim is unconscious, apply first aid and get immediate medical help.
- Never wear jewelry when working on this equipment. Jewelry can conduct electricity resulting in electric shock, or may get caught in moving components causing injury.

### **FIRE HAZARDS**

- Keep a fire extinguisher near the generator at all times. Do NOT use any carbon tetra-chloride type extinguisher. Its fumes are toxic, and the liquid can deteriorate wiring insulation. Keep the extinguisher properly charged and be familiar with its use. If there are any questions pertaining to fire extinguishers, consult the local fire department.

### **EXPLOSION HAZARDS**

- Properly ventilate any room or building housing the generator to prevent build-up of explosive gas.
- Do not smoke around the generator. Wipe up any fuel or oil spills immediately. Ensure that no combustible materials are left in the generator compartment, or on or near the generator, as FIRE or EXPLOSION may result. Keep the area surrounding the generator clean and free from debris.
- These generator sets may operate using one of several types of fuels. All fuel types are potentially FLAMMABLE and/or EXPLOSIVE and should be handled with care. Comply with all laws regulating the storage and handling of fuels. Inspect the unit's fuel system frequently and correct any leaks immediately. Fuel supply lines must be properly installed, purged and leak tested according to applicable fuel-gas codes before placing this equipment into service.
- Diesel fuels are highly FLAMMABLE. Gaseous fluids such as natural gas and liquid propane (LP) gas are extremely EXPLOSIVE. Natural gas is lighter than air, and LP gas is heavier than air; install leak detectors accordingly.



## INTRODUCTION

Thank you for purchasing this model of the standby generator set product line.

Every effort was expended to make sure that the information and instructions in this manual were both accurate and current at the time the manual was written. However, the manufacturer reserves the right to change, alter or otherwise improve this product(s) at any time without prior notice.

### ◆ READ THIS MANUAL THOROUGHLY

If any portion of this manual is not understood, contact the nearest Authorized Service Dealer for starting, operating and servicing procedures.

Throughout this publication, and on tags and decals affixed to the generator, DANGER, WARNING, CAUTION and NOTE blocks are used to alert personnel to special instructions about a particular service or operation that may be hazardous if performed incorrectly or carelessly. Observe them carefully. Their definitions are as follows:



**After this heading, read instructions that, if not strictly complied with, will result in personal injury or property damage.**



**After this heading, read instructions that, if not strictly complied with, may result in personal injury or property damage.**



**After this heading, read instructions that, if not strictly complied with, could result in damage to equipment and/or property.**

#### NOTE:

**After this heading, read explanatory statements that require special emphasis.**

These safety warnings cannot eliminate the hazards that they indicate. Common sense and strict compliance with the special instructions while performing the service are essential to preventing accidents.

Four commonly used safety symbols accompany the DANGER, WARNING and CAUTION blocks. The type of information each indicates is as follows:

 This symbol points out important safety information that, if not followed, could endanger personal safety and/or property of others.

 This symbol points out potential explosion hazard.

 This symbol points out potential fire hazard.

 This symbol points out potential electrical shock hazard.

The operator is responsible for proper and safe use of the equipment. The manufacturer strongly recommends that the operator read this Owner's Manual and thoroughly understand all instructions before using this equipment. The manufacturer also strongly recommends instructing other users to properly start and operate the unit. This prepares them if they need to operate the equipment in an emergency.

### ◆ OPERATION AND MAINTENANCE

It is the operator's responsibility to perform all safety checks, to make sure that all maintenance for safe operation is performed promptly, and to have the equipment checked periodically by an Authorized Service Dealer. Normal maintenance service and replacement of parts are the responsibility of the owner/operator and, as such, are not considered defects in materials or workmanship within the terms of the warranty. Individual operating habits and usage contribute to the need for maintenance service.

Proper maintenance and care of the generator ensure a minimum number of problems and keep operating expenses at a minimum. See an Authorized Service Dealer for service aids and accessories.

Operating instructions presented in this manual assume that the standby electric system has been installed by an Authorized Service Dealer or other competent, qualified contractor. Installation of this equipment is not a "do-it-yourself" project.

### ◆ HOW TO OBTAIN SERVICE

When the generator requires servicing or repairs, simply contact an Authorized Service Dealer for assistance. Service technicians are factory-trained and are capable of handling all service needs.

When contacting an Authorized Service Dealer or the factory about parts and service, always supply the complete model number of the unit as given on the front cover of this manual or on the DATA LABEL affixed to the unit.

#### AUTHORIZED SERVICE DEALER LOCATION

To locate the nearest AUTHORIZED SERVICE DEALER, please call this number:

**1-800-333-1322**

or locate us on the web at:

**www.generac.com**

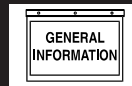
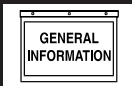

## IDENTIFICATION RECORD

### ◆ DATA LABEL

Every generator set has a DATA LABEL that contains important information pertinent to the generator. The data label, which can be found attached to the generator's lower connection box, lists the unit's serial number and its rated voltage, amps, wattage capacity, phase, frequency, rpm, power factor, etc.

### NOTE:

**For actual information related to this particular model, please refer to the Manual Drawing Listing located at the end of this manual, or to the data label affixed to the unit.**

#### ✦ Generator Model and Serial Number

This number is the key to numerous engineering and manufacturing details pertaining to your unit. Always supply this number when requesting service, ordering parts or seeking information.

### *Data Label*

| GENERATOR SET DATA                |                                | MADE IN USA   |
|-----------------------------------|--------------------------------|---|
| MODEL                             | <input type="text"/>           | SERIAL <input type="text"/>                               |
| RATED KW                          | <input type="text"/>           | RATED KVA <input type="text"/> PHASE <input type="text"/> |
| RATED VOLTAGE                     | <input type="text"/>           | RATED AMPS <input type="text"/>                           |
| POWER FACTOR                      | <input type="text"/>           | HERTZ <input type="text"/> ALT RPM <input type="text"/>   |
| ENGINE RPM                        | <input type="text"/>           | PRODUCTION DATE <input type="text"/>                      |
| ALTERNATOR SUBTRANSIENT REACTANCE |                                | <input type="text"/>                                      |
| ALTERNATOR TRANSIENT REACTANCE    |                                | <input type="text"/>                                      |
| CLASS <input type="checkbox"/>    | ROTOR <input type="checkbox"/> | STATOR WINDING INSULATION AT 25°C AMBIENT                 |

**GENERAC POWER SYSTEMS, INC.**

## EQUIPMENT DESCRIPTION

This equipment is a revolving field, alternating current generator set. It is powered by a gaseous fueled engine operating at 1800 rpm for 4-pole direct drive units, 3600 rpm for 2-pole direct drive units and 2300 - 3000 rpm for quiet drive gear units. See the Specifications section for exact numbers. The unit comes complete with a sound attenuated enclosure, internally mounted muffler, control console, main-line circuit breaker, battery charger, and protective alarms as explained in the following paragraph.

All AC connections, including the power leads from the alternator, 120 volt battery charger input and control connections to the transfer switch are available in the main connection box.

The generator incorporates the following generator features:

- Rotor and Stator insulation is Class H rated as defined by NEMA MG1-32.6, NEMA MG1-1.66. The generator is self ventilated and drip-proof constructed.
- The voltage waveform deviation, total harmonic content of the AC waveform and telephone influence factor have been evaluated and are acceptable according to NEMA MG1-32.

## ENGINE OIL RECOMMENDATIONS

The unit has been filled with 15W-40 engine oil at the factory. Use a high-quality detergent oil classified "For Service SJ or SH." Detergent oils keep the engine cleaner and reduce carbon deposits. Use oil having the following SAE viscosity rating, based on the ambient temperature range anticipated before the next oil change:

| Temperature                | Oil Grade (Recommended) |
|----------------------------|-------------------------|
| Above 80° F (27° C)        | SAE 30W or 15W-40       |
| 32° to 80° F (0° to 27° C) | SAE 20W-20 or 15W-40    |
| Below 32° F (0° C)         | See Note                |

—  CAUTION  —

-  Any attempt to crank or start the engine before it has been properly serviced with the recommended oil may result in an engine failure.

**NOTE:**

**For temperatures below 32° F, it is strongly recommended to use the optional Cold Weather Start Kit (part number listed in the Specification Section). The oil grade for temperatures below 32° F is 5W-30 synthetic oil.**



## COOLANT RECOMMENDATIONS

Use a mixture of half low silicate ethylene glycol base anti-freeze and deionized water. Cooling system capacity is listed in the specifications. Use only deionized water and only low silicate anti-freeze. If desired, add a high quality rust inhibitor to the recommended coolant mixture. When adding coolant, always add the recommended 50-50 mixture.

—  CAUTION  —

-  Do not use any chromate base rust inhibitor with ethylene glycol base anti-freeze or chromium hydroxide ("green slime") forms and will cause overheating. Engines that have been operated with a chromate base rust inhibitor must be chemically cleaned before adding ethylene glycol base anti-freeze. Using any high silicate anti-freeze boosters or additives will also cause overheating. The manufacturer also recommends that any soluble oil inhibitor is NOT used for this equipment.

—  DANGER  —

-  Do not remove the radiator pressure cap while the engine is hot or serious burns from boiling liquid or steam could result.
-  Ethylene glycol base antifreeze is poisonous. Do not use mouth to siphon coolant from the radiator, recovery bottle or any container. Wash hands thoroughly after handling. Never store used antifreeze in an open container because animals are attracted to the smell and taste of antifreeze even though it is poisonous to them.

## ENGINE PROTECTIVE DEVICES

The standby generator may be required to operate for long periods of time without an operator on hand to monitor such engine conditions as coolant temperature, oil pressure or rpm. For that reason, the engine has several devices designed to protect it against potentially damaging conditions by automatically shutting down the unit when the oil pressure is too low, the coolant temperature is too high, the coolant level is too low, or the engine is running too fast.

### NOTE:

**Engine protective switches and sensors are mentioned here for the reader's convenience. Also refer to the applicable control panel manual for additional automatic engine shutdown information.**

### ◆ COOLANT TEMPERATURE SENSING

An analog Water Temperature Sender (WTS) is located in the engine's cooling system. This sender is connected to the panel and allows the panel to monitor and display the temperature of the coolant system.

The WTS is a resistive device whose resistance changes based on coolant temperature. The resistance of the sender results in a voltage being developed across the sender. As the Coolant temperature increases, the resistance will decrease, causing the voltage to decrease. This changing voltage is converted to 4-20mA signal by a signal conditioner module. The corresponding 4-20mA signal is read by the control panel and displayed as the coolant temperature.

The control panel will monitor and display the coolant temperature anytime the DC input to the control panel is present.

If the temperature exceeds approximately 140° C (284° F), the engine shutdown will be initiated. The generator will automatically restart and the display will reset once the temperature has returned to an operating level.

### ◆ LOW COOLANT LEVEL

A Low Coolant Level (LCL) sensor is placed in the generators coolant system. This sensor allows the panel to detect a Low Coolant Level condition.

The LCL is a resistive device whose resistance changes rapidly based on the presence or absence of coolant.

The resistance of the LCL results in a voltage being developed across the LCL. This voltage changes as the resistance changes. This changing voltage is converted to 4-20mA signal by a signal conditioner module. The corresponding 4-20mA signal is read by the control panel and displayed as the low coolant level.

If the level of the engine coolant drops below the level of the low coolant level sensor, the engine shutdown will be initiated.

### ◆ OIL PRESSURE SENSING

An analog Oil Pressure Sender (OPS) is used for monitoring the engine oil pressure. This sender allows the control panel to measure and display the Engine oil pressure.

The OPS is a resistive device, whose resistance changes based on engine oil pressure. The resistance of the sender results in a voltage being developed across the sender. As the oil pressure increases, the resistance will decrease, causing the voltage to decrease. This changing voltage is converted to 4-20mA signal by a signal conditioner module. The corresponding 4-20mA signal is read by the control panel and displayed as the oil pressure.

The control panel will monitor and display oil pressure anytime the DC input to the control panel is present.

Should the oil pressure drop below the 8 psi range, the engine shutdown is initiated. The unit should not be restarted until oil is added. Turn the AUTO/OFF/MANUAL switch to the OFF position, then back to AUTO to restart.

### ◆ OVERCRANK SHUTDOWN

When the control panel receives a start signal, it initiates the programmed starting sequence. The start sequence consists of the number of crank attempts, the length of each crank attempt, and the rest time between each crank attempt. If the engine has not started by the end of the final crank attempt, an Overcrank alarm is generated, the control panel will sound the alarm and display the message "Failed to start".

### ◆ OVERSPEED SHUTDOWN

A speed circuit controls engine cranking, start-up, operation and shutdown. Engine speed signals are delivered to the circuit board whenever the unit is running. Should the engine over speed above a safe, preset value, the circuit board initiates an automatic engine shutdown. Contact the nearest Authorized Dealer if this failure occurs.

### ◆ RPM SENSOR LOSS SHUTDOWN

If the speed signal to the control panel is lost, engine shutdown will occur.

### ◆ DC FUSE

This fuse is located inside of the control panel. It protects the panel wiring and components from damaging overload. Always remove this fuse before commencing work on the generator. The unit will not start or crank if the fuse is blown. Replace the fuse with one of the same size, type, and rating. (See the exploded views and parts lists at the end of this manual for replacement part number.)



## FUEL SYSTEM

### ◆ FUEL REQUIREMENTS

The standby generator may be equipped with one of the following fuel systems:

- Natural gas fuel system
- Propane vapor (PV) fuel system
- Liquid propane (LP) fuel system

The Manual Drawing Listing that is affixed to the unit includes the "Identification Code," which may be used to identify the type of fuel system installed on the unit.

Recommended fuels should have a Btu content of at least 1,000 Btu's per cubic foot for natural gas; or at least 2,520 Btu's per cubic foot for LP gas. Ask the fuel supplier for the Btu content of the fuel.

Required fuel pressure for **natural gas is 11 inches to 14 inches water column (0.4 to 0.5 psi); and for liquid propane, 11 inches to 14 inches of water column (0.4 to 0.5 psi).**

#### NOTE:

**Any piping used to connect the generator to the fuel supply should be of adequate size to ensure the fuel pressure NEVER drops below 11 inches water column for natural gas or 11 inches water column for liquid propane for all load ranges.**

#### NOTE:

**It is the responsibility of the installer to make sure that only the correct recommended fuel is supplied to the generator fuel system. Thereafter, the owner/operator must make certain that only the proper fuel is supplied.**

### ◆ NATURAL GAS FUEL SYSTEM

Natural gas is supplied in its vapor state. In most cases, the gas distribution company provides piping from the main gas distribution line to the standby generator site. The following information applies to natural gas fuel systems.

- Gas pressure in a building is usually regulated by national, state and local codes.
- To reduce gas pressure to a safe level before the gas enters a building, a primary regulator is needed. The natural gas supplier may or may not supply such a regulator.
- It is the responsibility of the gas supplier to make sure sufficient gas pressure is available to operate the primary regulator.
- Gas pressure at the inlet to the fuel shutoff solenoid should not exceed approximately 14 inches water column (0.5 psi). Optimum pressure at the fuel shutoff solenoid is 11 inches water column (0.4 psi).

### ◆ PROPANE VAPOR WITHDRAWAL FUEL SYSTEM

This type of system utilizes the vapors formed above the liquid fuel in the supply tank. Approximately 10 to 20 percent of the tank capacity is needed for fuel expansion from the liquid to the vapor state. The vapor withdrawal system is generally best suited for smaller engines that require less fuel. The installer should be aware of the following:

- The natural gas and LP gas systems are similar. However, the natural gas system delivers gas at a pressure of approximately five inches water column to the carburetor.
- When ambient temperatures are low and engine fuel consumption is high, the vapor withdrawal system may not function efficiently.
- Ambient temperatures around the supply tank must be high enough to sustain adequate vaporization, or the system will not deliver the needed fuel volume.
- In addition to the cooling effects of ambient air, the vaporization process itself provides an additional cooling effect.

### ◆ LP FUEL SYSTEM

LP is supplied as a liquid in pressure tanks. It is usually made up of propane, butane, or a mixture of the two gases. Propane tends to vaporize readily even at temperatures as low as -20° F (-29° C). However, butane reverts to its liquid state when temperatures drop below 32° F (0° C).

LP in a liquid withdrawal system must be converted to its gaseous state before it is introduced into the engine carburetor. A vaporizer-converter is generally used to accomplish this. In such a converter, heated engine coolant is ported through the converter to provide the necessary heat for conversion of the fuel from a liquid to a gaseous state.

## SPECIFICATIONS

### ◆ GENERATOR

Type ..... Synchronous  
 Rotor Insulation ..... Class H  
 Stator Insulation ..... Class H  
 Total Harmonic Distortion ..... < 3.5%  
 Telephone Interference Factor (TIF) ..... < 50  
 Alternator Output Leads 1-phase ..... 4-wire  
 Alternator Output Leads 3-phase ..... 6-wire  
 Bearings ..... Sealed Ball  
 Coupling ..... Flexible Disc  
 Load Capacity (Standby Rating) ..... 70kW\*

\* NOTE: Generator rating and performance in accordance with ISO8528-5, BS5514, SAE J1349, ISO3046 and DIN 6271 Standards. KW rating is based on LPG fuel and may derate with natural gas.

Excitation System ..... Direct  
 Generator Output Voltage/kW - 60 Hz

|                           | kW | Amp | CB Size |
|---------------------------|----|-----|---------|
| 120/240V, 1-phase, 1.0 pf | 70 | 292 | 300     |
| 120/208V, 3-phase, 0.8 pf | 70 | 243 | 250     |
| 277/480V, 3-phase, 0.8 pf | 70 | 105 | 125     |

Generator Locked Rotor KVA Available @ Voltage Dip of 35%  
 Single-phase ..... 145 KVA  
 480V, 3-phase ..... 160 KVA  
 208V, 3-phase ..... 145 KVA

### ◆ ENGINE

Make ..... Generac  
 Model ..... V-type  
 Cylinders and Arrangement ..... 10  
 Displacement ..... 6.8 Liter  
 Bore ..... 3.55 in.  
 Stroke ..... 4.17 in.  
 Compression Ratio ..... 9-to-1  
 Air Intake System ..... Naturally Aspirated  
 Valve Seats ..... Hardened  
 Lifter Type ..... Hydraulic

#### Engine Parameters

Rated Synchronous RPM ..... 60 Hz, 1800  
 HP at rated kW ..... 60 Hz, 110.7

#### Exhaust System

Exhaust Flow at Rated Output 60 Hz ..... 557 cfm  
 Exhaust Temperature at Rated Output ..... 890° F

#### Combustion Air Requirements (Natural Gas)

Flow at rated power, 60 Hz ..... 205 cfm

#### Governor

Type ..... Electronic  
 Frequency Regulation ..... Isochronous  
 Steady State Regulation ..... ± 1/4 %  
 Adjustments:  
 Speed ..... Selectable

### Engine Lubrication System

Type of Oil Pump ..... Gear  
 Oil Filter ..... Full Flow, Cartridge  
 Crankcase Oil Capacity ..... 5 U.S. qts.

### ◆ COOLING SYSTEM

Type ..... Closed  
 Water Pump ..... Belt Driven  
 Fan Speed ..... 2030  
 Fan Diameter ..... 22 inches  
 Fan Mode ..... Pusher  
 Air Flow (inlet air including alternator and combustion air) ..... 5200 ft<sup>3</sup>/min.  
 Coolant Capacity ..... (4.5 U.S. gal.)  
 Heat Rejection to Coolant ..... 287,000 Btu/h  
 Maximum Operating Air Temp. on Radiator ..... 60° C (150° F)  
 Maximum Ambient Temperature ..... 50° C (140° F)

### ◆ FUEL SYSTEM

Type of Fuel ..... Propane or Natural Gas\*  
 Carburetor ..... Down Draft  
 Secondary Fuel Regulator ..... Standard  
 Fuel Shut-off Solenoid ..... Standard  
 Operating Fuel Pressure ..... 11 in. - 14 in. Water Column

#### Fuel Consumption - ft<sup>3</sup>/hr (Natural Gas/LPV)

| <i>Exercise Cycle</i> | <i>25% Load</i> | <i>50% Load</i> | <i>75% Load</i> | <i>100% Load</i> |
|-----------------------|-----------------|-----------------|-----------------|------------------|
| 110/44                | 260/104         | 500/200         | 696/280         | 1020/411         |

\* Engine is not field convertible between natural gas and propane. Jet size and ignition timing are factory set for the specific fuel.

### ◆ ELECTRICAL SYSTEM

Battery Charge Alternator ..... 12V, 30 Amp  
 Static Battery Charger ..... 12V, 2 Amp  
 Recommended Battery ..... 24F 525CCA  
 System Voltage ..... 12 Volts

#### Voltage Regulator

Type ..... Full Digital  
 Sensing ..... 3-phase  
 Regulation ..... ± 1/4%  
 Features ..... Built into H-100 Control Panel  
 V/F Adjustable, Adjustable Voltage and Gain

#### Power Adjustment for Ambient Conditions

Temperature Deration  
 3% for every 10° C above °C ..... 25  
 1.65% for every 10° above °F ..... 77  
 Altitude Deration  
 1% for every 100 m above m ..... 183  
 3% for every 1000 ft. above ft. .... 600

#### Controller ..... H-panel

Figure 1 — Interconnections

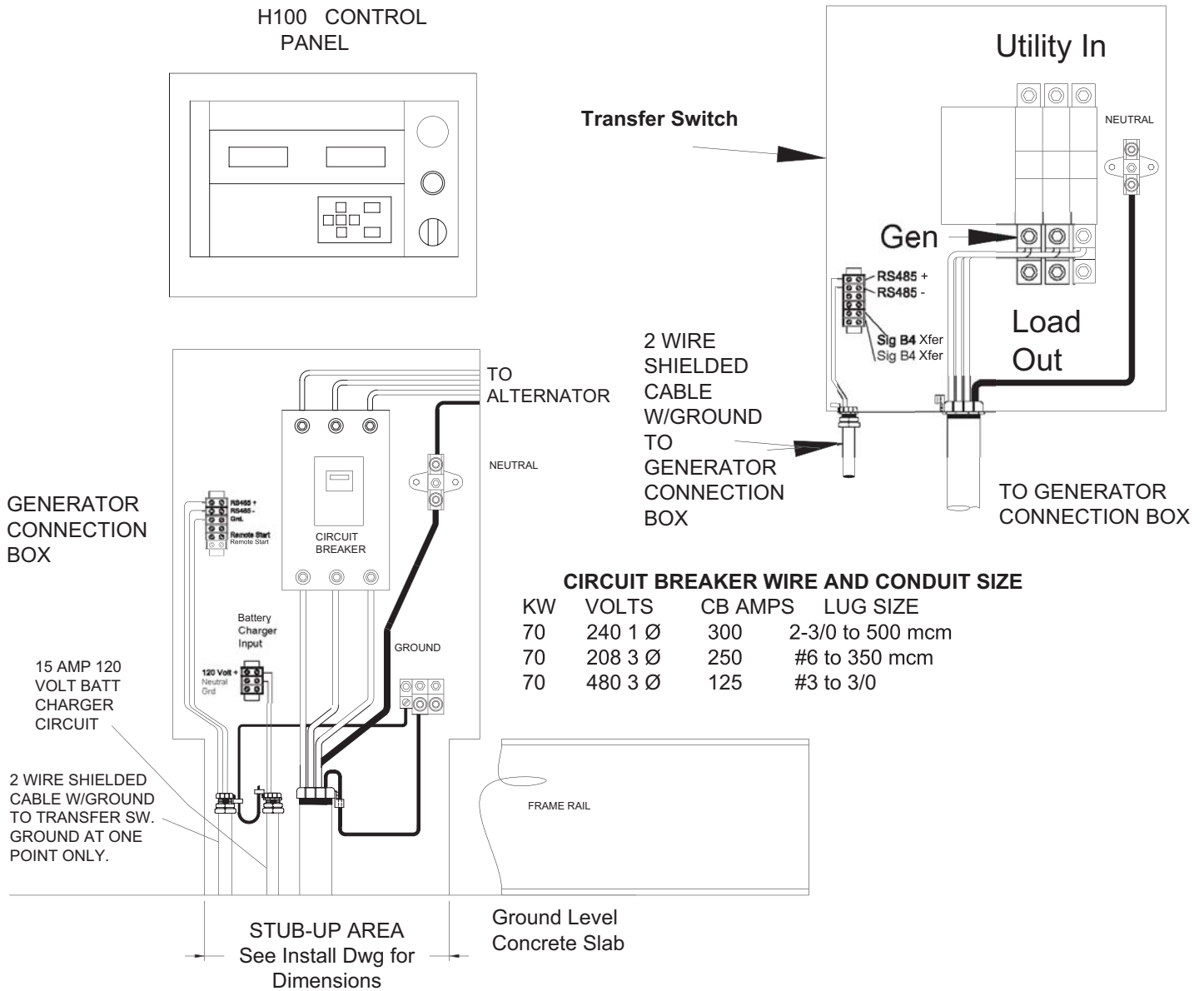

## ◆ COLD WEATHER KIT

For cold climates, optional cold weather kit (part number 0F6148A) is recommended. The kit includes:

- Battery Warmer
- 4" Junction Box with Hardware
- 6 qt. pack 5W-30 Synthetic Oil (engine)

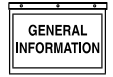

## 5.4L & 6.8L IGNITION DESCRIPTION

This single-fire Ignition is intended to operate with a 10-cylinder, 6.8L engine and an 8-cylinder, 5.4L engine.

The 6.8L engine uses a 40-1 crank sensor, a mag-pickup CAM sensor and individual coil-on-plug coils for each spark-plug.

The 5.4L engine uses a 36-1 crank sensor, a mag-pick-up CAM sensor and individual coil-on-plug coils for each spark-plug.

With a single-fire ignition, each high-voltage coil output is connected to one spark plug resulting in that spark plug being fired only during the compression cycle.

### Engine Timing versus Engine Speed for the 6.8L engine is:

| RPM      | NG/LP Engine Timing (BTDC) |
|----------|----------------------------|
| 1800 rpm | 22 degrees                 |
| 3600 rpm | 24 degrees                 |

### Engine Timing versus Engine Speed for the 5.4L engine is:

| RPM      | NG/LP Engine Timing (BTDC) |
|----------|----------------------------|
| 1800 rpm | 26 degrees                 |
| 3600 rpm | 26 degrees                 |

### ◆ IGNITION POWER-UP INPUT ("56 LINE INPUT")

When battery voltage is applied to this input the ignition will power-up. For the ignition to power itself down, battery voltage must be removed from this input.

### ◆ IGNITION ENABLE ("14 LINE INPUT")

This input must be connected to the +12V battery for the ignition to turn-on the coils. If this input is connected to battery ground the ignition will stop firing the coils and will power down within approximately 2 seconds. In the event that an ignition fault has occurred, however, the ignition will wait 60 seconds before powering down. This allows time to view the diagnostic LED located on the ignition board.

### NOTE:

**The ignition cover does not need to be removed to see the LED.**

### ◆ IGNITION SHUTDOWN ON LOSS OF CRANK OR CAM SIGNALS

The ignition will stop firing the coils immediately following the loss of the crank signal. The ignition will stop firing the coils after approx. 3 seconds following the loss of the cam signal.

### ◆ DIAGNOSTIC BLINK PATTERNS (RED LED LOCATED ON THE IGNITION CONTROL BOARD)

During normal ignition operation the RED LED flashes at a 0.5 sec ON and a 0.5 sec OFF rate. This is considered one (1) blink.

LED Fault Code with Priority as shown:

1. No Crank Signal: LED blinks 2 times, is OFF for 3.0 seconds and then repeats
2. No CAM Signal: LED blinks 3 times, is OFF for 3.0 seconds and then repeats

Only one fault is displayed at a time. If multiple faults exist then the highest priority fault must be resolved prior to a lower priority fault being displayed. In the event that an ignition fault has occurred the ignition will wait 60 seconds before powering down.

### NOTE:

**The ignition cover does not need to be removed to see the LED.**

## GENERATOR AC LEAD CONNECTIONS

See "Voltage Codes". This generator may be rated at any one of three voltages, either single-phase or three-phase. The electrical wires in the unit's AC connection (lower) panel should be installed according to the number of leads and the voltage/phase required for the application. If there are any questions regarding lead connection, refer to the wiring diagrams at the back of this manual.

Voltage codes apply to the type of stator assembly installed on a particular generator.

### ◆ FOUR-LEAD, SINGLE-PHASE STATOR

Four-lead generators (see Figure 7.1) are designed to supply electrical loads with voltage code "A" (240V, 1-phase, 60 Hz). Electrical power is produced in the stator power windings. These windings were connected at the factory to the main circuit breaker as shown in Figure 7.1.

The rated voltage between each circuit breaker terminal is 240V. The rated voltage between each circuit breaker terminal and the neutral point 00 is 120V.

Figure 7.1 — Four-lead, Single-phase Stator

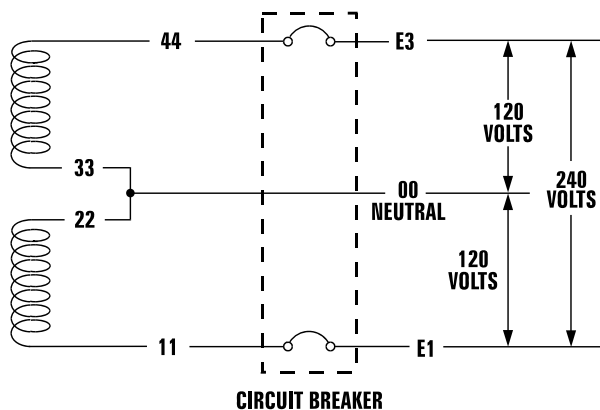

## ALTERNATOR POWER WINDING CONNECTIONS

### ◆ 3-PHASE ALTERNATORS

The generator is designed to supply 3-phase electrical loads. Electric power is produced in the alternator power windings. These windings were connected at the factory to the main circuit breaker with a "Y" configuration as shown in Figures 7.2 and 7.3.

The rated voltage between circuit breaker terminals E1-E2, E1-E3 and E2-E3 is either 480V or 208V depending on the model.

The rated voltage between each circuit breaker terminal and the neutral point 00 is either 277V or 120V depending on the model.

Figure 7.2 — Stator Power Winding Connections - 3-phase, 277/480V (6 Lead)

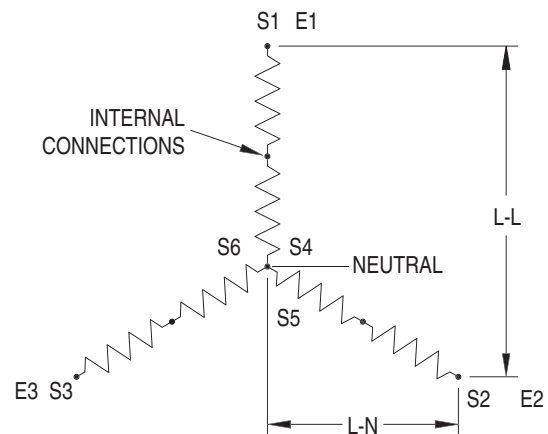
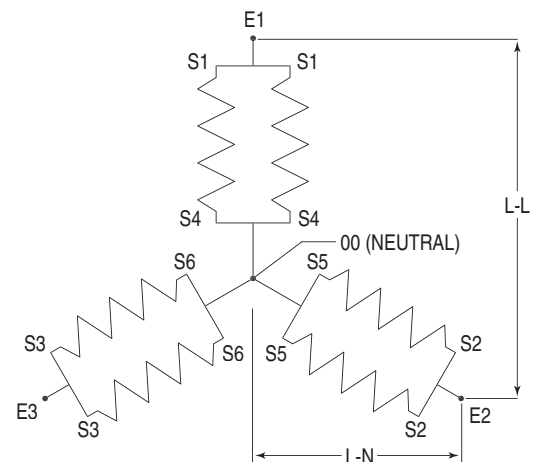

Figure 7.3 — Stator Power Winding Connections - 3-phase, 120/208V (6 Lead)





## INSTALLATION

Refer to the separate “Installation Guide” supplied with the unit.

## PREPARATION BEFORE START-UP

The instructions in this section assume that the standby generator has been properly installed, serviced, tested, adjusted and otherwise prepared for use by a competent, qualified installation contractor. Be sure to read the “Safety Rules”, as well as all other safety information in this manual, before attempting to operate this (and related) equipment.

Before starting the generator for the first time, the installer must complete the following procedures. For follow-up maintenance information and/or service intervals, please refer to the “Maintenance” section and the “Service Schedule”.

### ◆ TRANSFER SWITCH

If this generator is used to supply power to any electrical system normally powered by an electric utility, the National Electrical Code requires that a transfer switch be installed. The transfer switch prevents electrical backfeed between two different electrical systems. (For additional information, see the applicable transfer switch manual for this unit.) The transfer switch, as well as the generator and other standby components, must be properly located and mounted in strict compliance with applicable codes, standards and regulations.

### ◆ FUEL SYSTEM

Make sure the fuel supply system to the generator (a) delivers the correct fuel at the correct pressure and (b) is properly purged and leak tested according to code. No fuel leakage is permitted. See “Specifications” for more information.

### ◆ GENERATOR SET LUBRICATION

Check the engine crankcase oil level before operating and add oil to the proper level – the dipstick “FULL” mark. Never operate the engine with the oil level below the dipstick “ADD” mark. See “Specifications” and “Engine Oil Recommendations”.

#### NOTE:

**This engine is shipped from the manufacturer with “break-in” oil. This oil should be changed after 30 hours of operation.**

## ◆ PRIOR TO INITIAL START-UP



- ⚠ Prior to initially starting the generator, it must be properly prepared for use. Any attempt to crank or start the engine before it has been properly serviced with the recommended types and quantities of engine fluids (oil, coolant, fuel, etc.) may result in an engine failure.

### ◆ ENGINE COOLANT

Have the engine cooling system properly filled with the recommended coolant mixture. Check the system for leaks and other problems. See “Specifications” and “Coolant” sections.

### ◆ BELT TENSION

Check the engine-fan belt tension and condition prior to placing the unit into service and at recommended intervals. Belt tension is correct when a force of approximately 22 pounds (10 kg), applied midway between pulleys, deflects the belt about 3/8- to 5/8-inch (10 to 16 mm).

### ◆ ELECTRICAL SYSTEM

Make sure the generator is properly connected to an approved earth ground.

Make sure the generator battery is fully charged, properly installed and interconnected, and ready for use.

#### NOTE:

**Battery charger must be connected to 120 VAC, 15 amp circuit to operate.**

Check to ensure that there are no loose electrical connections. Restrain any loose wires to keep them clear of any moving generator set components.

## INITIAL INSPECTION FOR GENSET STARTUP

**Inspect for the following.**

- Freight Damage.
- Manuals present.
- Fluid Levels (Oil, coolant, battery, Gear Drive).
- Correct fuel piping.
- Adequate air flow, clearances and ventilation per installation drawings and applicable codes.
- Correct AC and DC wire size, connections and grounding. Control and communication wiring to/from the transfer switch must be run in a separate conduit from the AC power leads.



- **Battery charger connection to 120 VAC.**
- Communication wires connected between transfer switch and generator (HTS only).
- Unit secured to pad.

## START-UP CHECKLIST



### WARNING

**⚠ Before working on the generator, ensure the following:**

- **The AUTO/OFF/MANUAL switch is in the OFF position.**
- **The 120VAC supply to the battery charger is switched OFF.**

### ◆ PREPARATION FOR START-UP

- Ensure that the 120VAC circuit breaker to the battery charger is open.
- Remove the fuse from the the control panel. Open the front door of the control box and remove the 15 Amp ATO fuse in the lower left-hand corner of the control box.
- Connect the battery cables to the battery. Attach negative battery cable last.
- Close the 120VAC circuit breaker to the battery charger.
- Measure the voltage at the battery before and after the charger is turned on.
- Verify all AC electrical connections are tight at the circuit breaker and transfer switch.
- Visually inspect entire area looking for loose paper, plastic wrappings, leaves, etc.
- Check all hoses clamps fittings for leaks or damage.
- Check all electrical plugs throughout the generator. Ensure each plug is seated correctly and fully inserted into its receptacle.
- Verify the AUTO/OFF/MANUAL switch is in OFF position.
- Open the valve to the engine fuel line.
- Bleed the fuel system of air. (necessary for long fuel lines).
- Open the generator main line circuit breaker.
- Connect a manometer to the gas line and record the static pressure. It must be as listed in the Specifications.
- Insert the fuse into the control panel.
- Move the AUTO/OFF/MANUAL switch to the manual position. The engine should now crank and start.
- Check voltage at the generator terminals.
- For 3-phase units, check phase rotation at the transfer switch terminals. The generator phase rotation must match the utility phase rotation.
- Check for coolant, fuel, oil, and exhaust leaks.
- Close the generators main line circuit breaker.
- Turn the generator set off.
- Connect the UTILITY supply to the transfer switch.
- Set the AUTO/OFF/MANUAL switch to AUTO.
- Disconnect utility power before the transfer switch.
  - Engine should start, transfer to load.
  - Run at least 15 minutes on generator power. Make certain all 3-phase loads are functioning correctly (correct phase rotation).
- Reconnect Utility power
  - Transfer switch will transfer back to Utility and engine will shut down within the given time parameters set up for the specific transfer switch and controller.
- Install all covers, access plates and door panels.
- Put the Owners Manual in a safe and accessible place.
- Make certain the AUTO/OFF/MANUAL switch is in the AUTO position.

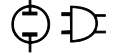
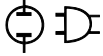

## GENERATOR CONTROL AND OPERATION

Refer to the appropriate control panel operator's manual for this unit.

## OPERATING UNIT WITH MANUAL TRANSFER SWITCH

If the generator was installed in conjunction with a transfer switch capable of manual operation only, the following procedure applies. A manually operated transfer switch is one that will not provide automatic start-up and does not include an intelligence circuit.

### ◆ ENGINE START-UP AND TRANSFER

For additional information, refer to the applicable control panel manual for this unit, as well as any literature pertaining to the specific transfer switch.



⚠ The Maintenance Disconnect Switch and the AUTO/OFF/MANUAL switches (if so equipped) must be set properly, or the generator will crank and start as soon as the utility power to the transfer switch is turned off. Refer to applicable control panel and transfer switch manuals for more information.

⚠ Do not proceed until certain that utility source voltage is available to the transfer switch and the transfer switch main contacts are set to UTILITY.

⚠ Do not attempt manual operation until all power supplies to the transfer switch have been positively turned off, or extremely dangerous - possibly lethal - electrical shock will result.

⚠ Transfer switch enclosure doors should be kept closed and locked. Only authorized personnel should be allowed access to the transfer switch interior. Extremely high and dangerous voltages are present in the transfer switch.

In order to transfer load from the utility source to the generator, follow these directions:

- Turn OFF or disconnect the utility power circuit to the transfer switch, using the means provided (such as the utility source main line circuit breaker).
- Set the transfer handle to its UTILITY (NORMAL) position with load circuits connected to the utility power supply.
- Set the standby generator's main line circuit breaker to its OFF (or OPEN) position.
- Start the generator.



⚠ Do not crank the engine continuously for longer than 30 seconds, or the heat may damage the starter motor.

- Let engine stabilize and warm up.
- Check all applicable instrument and gauge readings. When certain that all readings are correct, move the transfer switch manual handle to its STANDBY (GENERATOR) position, i.e., load circuits supplied by the generator.
- Set the standby generator's main line circuit breaker to its ON (or CLOSED) position.
- Load circuits are now powered by the standby generator.

### ◆ RETRANSFER AND SHUTDOWN

For additional information, refer to the applicable control panel manual for this unit, as well as any literature pertaining to the specific transfer switch.

To transfer the load back to the utility power source and shut down the generator, follow these directions:

- Set the standby generator's main line circuit breaker to its OFF (or OPEN) position.
- Manually move the transfer switch handle to its UTILITY (NORMAL) position, i.e., load circuits connected to the utility.
- Turn ON the utility power supply to the transfer switch, using the means provided (such as the utility power source main line circuit breaker).
- Let the generator run at no-load for a few minutes to stabilize internal temperatures.
- Shut down the generator.

## OPERATING UNIT WITH AUTOMATIC TRANSFER SWITCH

If the generator has been installed with an automatic transfer switch, such as an RTS, HTS, or GTS-type transfer switch, the engine may be started and stopped automatically or manually.

### NOTE:

**Refer to the applicable manual for your transfer switch and to "Transfer Switch Start Signal Connections". In addition, please note the dangers under "Engine Start-up and Transfer."**





## MAINTENANCE PERFORMED BY AUTHORIZED SERVICE FACILITIES

### —▲ WARNING ▲—

▲ Before working on the generator, ensure the following:

- The **AUTO/OFF/MANUAL** switch is in the **OFF** position.
- The **15A** fuse has been removed from the control box.
- The **120VAC** supply to the battery charger is switched **OFF**.

### ◆ EVERY THREE MONTHS

1. Check battery state of charge and condition.
2. Inspect and test fuel system.
3. Check transfer switch.
4. Inspect exhaust system.
5. Check engine ignition system.
6. Check fan belts.

### ◆ ONCE EVERY SIX MONTHS

1. Test Engine Safety Devices (low oil pressure, low coolant level, high coolant temperature).

### ◆ ONCE ANNUALLY

1. Test engine governor. Adjust or repair, if needed.
2. Clean, inspect generator.
3. Flush cooling system.

### ◆ FIRST 30 OPERATING HOURS

1. Change engine "break-in" oil and filter.

### ◆ FIRST 100 OPERATING HOURS

1. Change engine oil and oil filter. (After initial change, service engine oil and filter at 150 operating hours or 6 months, whichever comes first.)

### ◆ EVERY 500 OPERATING HOURS

1. Service air cleaner.
2. Check starter.
3. Check engine DC alternator.

## COOLING SYSTEM

Air intake and outlet openings in the generator compartment must be open and unobstructed for continued proper operation. This includes such obstructions as high grass, weeds, brush, leaves and snow.

Without sufficient cooling and ventilating air flow, the engine/generator quickly overheats, which causes it to shut down.

### —▲ WARNING ▲—

▲ The exhaust system parts from this product get extremely hot and remain hot after shutdown. High grass, weeds, brush, leaves, etc. must remain clear of the exhaust. Such materials may ignite and burn from the heat of the exhaust system.

## CHECKING FLUID LEVELS

### ◆ CHECK ENGINE OIL

Check engine crankcase oil level (Figure 10.1) at least every 20 hours of operation, or prior to use.

- Remove oil dipstick and wipe dry with a clean, lint-free cloth.
- Install oil dipstick, then remove again.
- Oil should be between **FULL** and **ADD** marks.
- If oil level is below the dipstick **ADD** mark, remove oil fill cap. Add the recommended oil to bring oil level up to the **FULL** mark. **DO NOT FILL ABOVE THE "FULL" MARK.** See "Engine Oil Recommendations" for recommended oils.

Figure 10.1 - Oil Dipstick and Oil Fill Cap

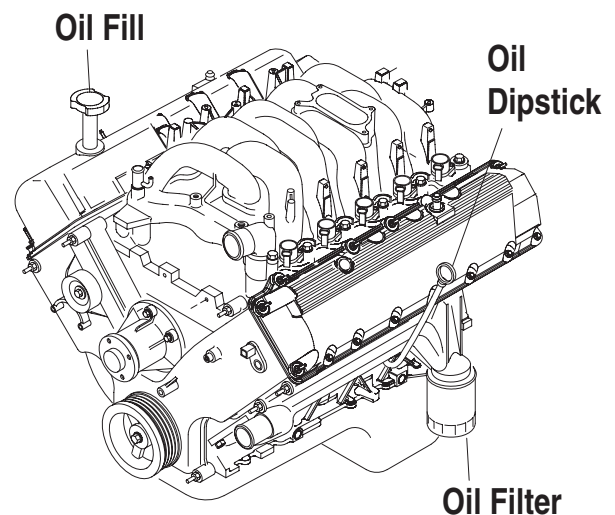

### ◆ BATTERY FLUID

Check battery electrolyte fluid at least once weekly. Fluid should cover separators in all battery cells. If fluid level is low, add distilled water to cover tops of separators. **DO NOT USE TAP WATER IN BATTERY.**



### ◆ ENGINE COOLANT

Check coolant level in coolant recovery bottle. See the “Specifications” section.

- Add recommended coolant mixture as necessary.
- Periodically remove radiator pressure cap to make sure the coolant recovery system is functioning properly. Coolant should be at bottom of radiator filler neck. If coolant level is low, inspect gasket in radiator pressure cap. Replace cap, if necessary. To have pressure cap tested, contact an Authorized Service Dealer. Inspect cooling system and coolant recovery system for leaks.

## MAINTENANCE OWNER/ OPERATOR CAN PERFORM

### ◆ CHECK ENGINE OIL LEVEL

Refer to the “Checking Fluid Levels” section.

### ◆ CHECK BATTERY

- Check battery fluid level each week as outlined under “Check Fluid Levels”.
- Check battery cables for condition, tightness, corrosion or damage. Clean, tighten or replace as necessary.

### ◆ EXERCISE SYSTEM

Start the generator engine at least once every seven days and let it run at least 20 minutes. For more detailed exercise information, see the respective sections in the Control Panel Technical Manual that is supplied with the unit.

### ◆ INSPECT COOLING SYSTEM

- Inspect engine cooling system at least once each month.
- Check hoses for damage, deterioration, leaks, etc. Correct any discrepancies found.
- Check hose clamps for tightness.

### ◆ CHECK ENGINE COOLANT LEVEL

See the “Checking Fluid Levels” section.

### ◆ PERFORM VISUAL INSPECTION

Complete a thorough visual inspection of the entire engine-generator monthly. Look for obvious damage, loose, missing or corroded nuts, bolts and other fasteners. Look for fuel, oil or coolant leaks.

### ◆ INSPECT EXHAUST SYSTEM

Inspect the exhaust system at least once every three months. Check all exhaust system pipes, mufflers, clamps, etc. for condition, tightness, leaks, security, damage.

### ◆ CHECK FAN BELT

- Inspect fan belts every three months. Replace any damaged, deteriorated, worn or otherwise defective belt.
- Check fan belt tension. Thumb pressure, exerted midway between pulleys, should deflect about 3/8 to 5/8 inch. Adjust belt tension as required.

### ◆ INSPECT ENGINE GOVERNOR

Visually inspect electronic governor.



- ⚠ Do not attempt to adjust the governor. Only qualified service facilities should adjust the governor. Excessively high operating speeds are dangerous and increase the risk of personal injury. Low speeds impose a heavy load on the engine when adequate engine power is not available and may shorten engine life. Correct rated frequency and voltage are supplied only at the proper governed speed. Some connected electrical load devices may be damaged by incorrect frequency and/or voltage. Only qualified service technicians should adjust the governed speed.

### ◆ CHANGING ENGINE OIL

Refer to maintenance performed by authorized service facilities for engine oil and filter change frequencies.

Drain the oil while the engine is still warm from running. This means warm up the engine, shut it down and drain immediately as follows:

1. Remove OIL DRAIN HOSE from its retaining clip.
2. Loosen and remove OIL DRAIN HOSE CAP. Drain oil completely into suitable container.
3. When all oil has drained, install and tighten OIL DRAIN HOSE CAP, and re-install into its retaining clip.
4. Turn OIL FILTER (Figure 10.2) counterclockwise and remove. Dispose of old filter.
5. Apply light coating of new engine oil to seal of new oil filter. Install FILTER and tighten by hand only. DO NOT OVERTIGHTEN.



- Remove OIL FILL CAP. Add recommended oil (see SPECIFICATIONS). DO NOT FILL ABOVE THE DIPSTICK "FULL" MARK. Crankcase oil capacity is 4.0 U.S. quarts (3.8 liters).

—▲ CAUTION ▲—

▲ After refilling the crankcase with oil, always check oil level on dipstick. NEVER OPERATE ENGINE WITH OIL BELOW THE DIPSTICK "ADD" MARK.

- Start engine and check for oil leaks.

**Figure 10.2 - Oil Filter**

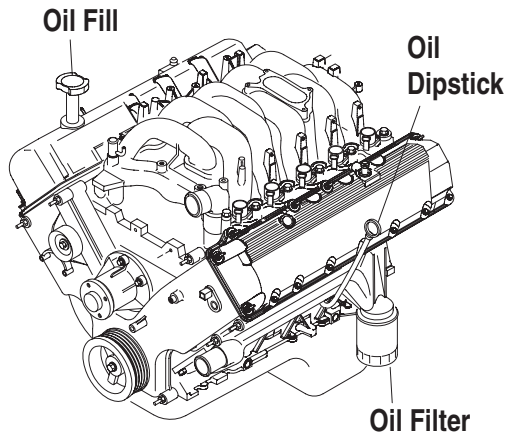

## ◆ CHANGING THE ENGINE AIR CLEANER

To replace the engine air cleaner, remove the air cleaner cover and replace the air filter making sure it is positioned properly before reattaching the cover.

**Figure 10.3 — Engine Air Filter**

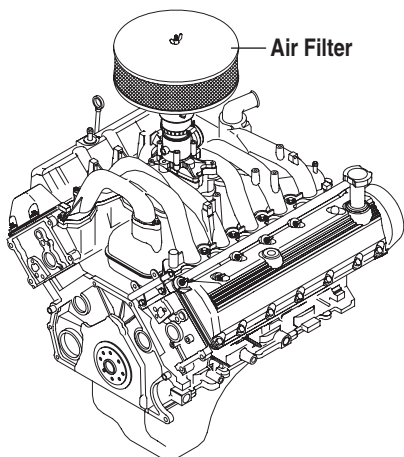

See the "Service Schedule" section for air cleaner maintenance.

## ◆ SPARK PLUGS

Reset the spark plug gap or replace the spark plugs as necessary.

- Clean the area around the base of the spark plugs to keep dirt and debris out of the engine. Clean by scraping or washing using a wire brush and commercial solvent. Do not blast the spark plugs to clean.
- Remove the spark plugs and check the condition. Replace the spark plugs if worn or if reuse is questionable. See the "Service Schedule" section for recommended inspection.
- Check the spark plug gap using a wire feeler gauge. Adjust the gap to 1.14 mm (0.045 inch) by carefully bending the ground electrode (Figure 10.4).

**Figure 10.4 – Setting the Spark Plug Gap**

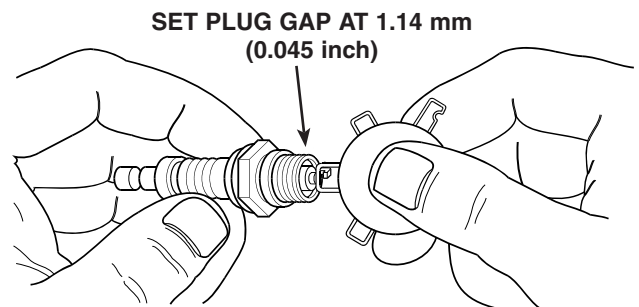

## ◆ COOLANT CHANGE

Every year, have an Authorized Service Facility drain, flush and refill the cooling system. See the "Specifications" section for cooling system recommendations.

## MISCELLANEOUS MAINTENANCE

### ◆ CLEANING THE GENERATOR

Keep the generator as clean and as dry as possible. Dirt and moisture that accumulates on internal generator windings have an adverse effect on insulation resistance.

Periodically clean generator exterior surfaces. A soft brush may be used to loosen caked on dirt. Use a vacuum system or dry, low pressure air to remove any accumulations of dirt. The generator is housed inside an all-weather enclosure, clean the enclosure with a soft, damp cloth or sponge and water.

Once each year, have the generator cleaned and inspected by an Authorized Service Dealer. That dealer will use dry, low pressure air to clean internal windings. Parts inside the control console should be cleaned and inspected at this time as well.



Finally, have the insulation resistance of stator and rotor windings checked. If insulation resistances are excessively low, the generator may require drying.

### ◆ BATTERY

All lead-acid storage batteries discharge when not in use. Refer to specific instructions and warnings that accompany the battery. If such information is not available, observe the following precautions when handling a battery:

- DO NOT use jumper cables and a booster battery to crank or start the generator engine.
- DO NOT recharge a weak battery while it is installed in the generator. Remove battery from generator and recharge in a well-ventilated area, away from fuel vapors, sparks, heat or flames.
- Battery electrolyte fluid is an extremely caustic sulfuric solution that can cause severe burns. DO NOT permit fluid to contact eyes, skin, clothing, painted surfaces, wiring insulation, etc. If any battery fluid is spilled, flush the affected area with clear water immediately.
- Always wear safety glasses, rubber apron and gloves when handling a battery.
- Batteries give off explosive hydrogen gas while charging. The gas can form an explosive mixture around the battery for several hours after charging. Any spark, heat or flames can ignite the gas and cause an explosion which can shatter the battery, causing blindness or other serious injury.

### ◆ BATTERY MAINTENANCE

The battery should be inspected per the “Service Schedule” section. The following procedure should be followed for inspection:

1. Inspect the battery posts and cables for tightness and corrosion. Tighten and clean as necessary.
2. Check the battery fluid level of unsealed batteries and, if necessary, fill with DISTILLED WATER ONLY. DO NOT USE TAP WATER IN BATTERIES.
3. Have the state of charge and condition checked. This should be done with an automotive-type battery hydrometer.

### —▲ DANGER ▲—

- ▲ Storage batteries give off explosive hydrogen gas. This gas can form an explosive mixture around the battery for several hours after charging. The slightest spark can ignite the gas and cause an explosion. Such an explosion can shatter the battery and cause blindness or other injury. Any area that houses a storage battery must be properly ventilated. Do not allow smoking, open flame, sparks or any spark producing tools or equipment near the battery.
- ▲ Battery electrolyte fluid is an extremely caustic sulfuric acid solution that can cause severe burns. Do not permit fluid to contact eyes, skin, clothing, painted surfaces, etc. Wear protective goggles, protective clothing and gloves when handling a battery. If the fluid is spilled, flush the affected area immediately with clear water.
- ▲ Do not use any jumper cables or booster battery to crank and start the generator engine. If the battery has completely discharged, remove it from the generator for recharging.

### —▲ WARNING ▲—

- ▲ Be sure the AUTO/OFF/MANUAL switch is set to the OFF position before connecting the battery cables. If the switch is set to AUTO or MANUAL, the generator can crank and start as soon as the battery cables are connected.
- ▲ Be sure the 120VAC power supply to the battery is turned OFF, or sparking may occur at the battery posts as the cables are attached and cause an explosion.

### ◆ BATTERY REPLACEMENT

When replacing batteries, use the same number and the type of battery that was supplied with the unit, and is listed in the parts list in the back of this manual.

#### NOTE:

**The BCI number should be located directly on the battery.**

### REPAIR PARTS

The latter portion of this manual consists of exploded views, parts lists and electrical data pertaining to this generator set. The parts lists consist of (a) an item number, (b) a part number, (c) the quantity required, and (d) a description of the part. The item number corresponds to an identical number on the exploded view drawing.



## Standby Generator Sets Service Schedule



### SERVICE SCHEDULE

#### 30 KW - 150 KW STANDBY GAS ENGINE DRIVEN GENERATOR SETS

The following is a recommended maintenance schedule for standby gas engine driven generator sets from 30kW to 150 kW in size. The established intervals in the schedule are the maximum recommended when the unit is used in an average service application. They will need to be decreased (performed more frequently) if the unit is used in a severe application. Use calendar time, from the previous maintenance interval to determine the next required maintenance interval.

#### Service Maintenance Interval Information:

The various service maintenance intervals are designated by interval numbers as follows:

- 1 An early inspection of the generator set to insure it is ready to operate when required and to identify any potential problem areas.

*This inspection may be performed by the end user providing the following safety steps are taken to prevent the engine from starting automatically without warning:*

**To prevent injury, perform the following steps in the order indicated before starting any maintenance:**

- **Disable the generator set from starting and/or connecting to the load by setting the control panel Auto/Off/Manual switch to the “OFF” position.**
- **Remove the 15 amp control panel fuse.**
- **Turn off the battery charger.**
- **Remove the negative battery cable.**

**The battery charger must be turned off BEFORE removing the battery cable to prevent an over current condition from burning out sensitive control panel components and circuits.**

**Following all maintenance, reverse these steps to insure the unit is returned to standby setup for normal operation when required.**

- 2 A wear-in service inspection of the generator set to insure it is ready to operate and carry the load when required, and to identify any potential problem areas.

*Performed **ONLY ONCE** following the first three months or the first 30 hours of operation after purchase of the unit.*

*This inspection contains some maintenance tasks which require special tools, equipment, and/or knowledge to accomplish and should be performed only by an Authorized Service Dealer.*

- 3 An operational inspection of the generator set to insure it is ready to operate and carry the load when required, and to identify any potential problem areas.

*Performed semi-annually or following each 50 hours of operation of the unit.*

*This inspection contains some maintenance tasks which require special tools, equipment, and/or knowledge to accomplish and should be performed only by an Authorized Service Dealer.*

- 4 A mid-level inspection of the generator set to insure it is ready to operate and carry the load when required, and to identify any potential problem areas.

*Performed annually or following each 100 hours of operation of the unit.*

*This inspection contains some maintenance tasks which require special tools, equipment, and/or knowledge to accomplish and should be performed only by an Authorized Service Dealer.*

- 5 A comprehensive inspection of the generator set to insure it is properly serviced and ready to operate and carry the load when required, and to identify any potential problem areas.

*Performed annually or following each 250 hours of operation of the unit.*

*This inspection contains some maintenance tasks which require special tools, equipment, and/or knowledge to accomplish and should be performed only by an Authorized Service Dealer.*



## Standby Generator Sets Service Schedule



| Maintenance Tasks   | Level 1                                 | Task Comp. (Date-Initials) | Level 2  | Task Comp. (Date-Initials) | Level 3                                    | Task Comp. (Date-Initials) | Level 4                                | Task Comp. (Date-Initials) | Level 5                                   | Task Comp. (Date-Initials) |
|---|---|----------------------------|--|----------------------------|--|----------------------------|--|----------------------------|---|----------------------------|
|   | Recommended to be done monthly/ 10 hrs. |                            | Required to be done 3 months/ Break-in 30 hrs. |                            | Required to be done Semi-annually/ 50 hrs. |                            | Required to be done Annually/ 100 hrs. |                            | Required to be done Bi-annually/ 250 hrs. |                            |
| 1. Disable the unit from operating per the first page warning.  | <input type="checkbox"/>                |                            | <input type="checkbox"/>                       |                            | <input type="checkbox"/>                   |                            | <input type="checkbox"/>               |                            | <input type="checkbox"/>                  |                            |
| 2. Check the engine oil level. Adjust as necessary.   | <input type="checkbox"/>                |                            | <input type="checkbox"/>                       |                            | <input type="checkbox"/>                   |                            | <input type="checkbox"/>               |                            | <input type="checkbox"/>                  |                            |
| 3. Check the engine coolant level. Adjust as necessary.   | <input type="checkbox"/>                |                            | <input type="checkbox"/>                       |                            | <input type="checkbox"/>                   |                            | <input type="checkbox"/>               |                            | <input type="checkbox"/>                  |                            |
| 4. Check the engine coolant thermal protection level. Correct as necessary.   |   |                            |  |                            |  |                            | <input type="checkbox"/>               |                            | <input type="checkbox"/>                  |                            |
| 5. Check the natural gas delivery system for leaks and correct pressure on gas engine driven units. Tighten connections as necessary. | <input type="checkbox"/>                |                            | <input type="checkbox"/>                       |                            | <input type="checkbox"/>                   |                            | <input type="checkbox"/>               |                            | <input type="checkbox"/>                  |                            |
| 6. Check the air inlets and outlets for debris. Clean as necessary.   | <input type="checkbox"/>                |                            | <input type="checkbox"/>                       |                            | <input type="checkbox"/>                   |                            | <input type="checkbox"/>               |                            | <input type="checkbox"/>                  |                            |
| 7. Check the battery electrolyte level and specific gravity if accessible. Adjust as necessary.                                       | <input type="checkbox"/>                |                            | <input type="checkbox"/>                       |                            | <input type="checkbox"/>                   |                            | <input type="checkbox"/>               |                            | <input type="checkbox"/>                  |                            |
| 8. Check the battery posts, cables, and charger for loose connections, corrosion, and proper operation. Correct as necessary.         | <input type="checkbox"/>                |                            | <input type="checkbox"/>                       |                            | <input type="checkbox"/>                   |                            | <input type="checkbox"/>               |                            | <input type="checkbox"/>                  |                            |
| 9. Check the unit wiring for loose connections, corrosion, and damage. Correct as necessary.  | <input type="checkbox"/>                |                            | <input type="checkbox"/>                       |                            | <input type="checkbox"/>                   |                            | <input type="checkbox"/>               |                            | <input type="checkbox"/>                  |                            |



## Standby Generator Sets Service Schedule



| Maintenance Tasks  | Level 1                                 | Task Comp. (Date-Initials) | Level 2  | Task Comp. (Date-Initials) | Level 3                                    | Task Comp. (Date-Initials) | Level 4                                | Task Comp. (Date-Initials) | Level 5                                   | Task Comp. (Date-Initials) |
|--|---|----------------------------|--|----------------------------|--|----------------------------|--|----------------------------|---|----------------------------|
|  | Recommended to be done monthly/ 10 hrs. |                            | Required to be done 3 months/ Break-in 30 hrs. |                            | Required to be done Semi-annually/ 50 hrs. |                            | Required to be done Annually/ 100 hrs. |                            | Required to be done Bi-annually/ 250 hrs. |                            |
| 10. Check the engine accessory drive belts and fan coupling device if equipped for correct tension, wear, weather cracking, and damage. Replace as necessary.  |   |                            | ○  |                            |  |                            | ○                                      |                            | ○   |                            |
| 11. Check the engine valve clearance/lash. Adjust as necessary.  |   |                            |  |                            |  |                            | ○                                      |                            | ○   |                            |
| 12. Visually inspect the unit looking for leaks, wear or damage, loose connections or components, and corrosion. Correct as necessary.   |   |                            |  |                            |  |                            | ○                                      |                            | ○   |                            |
| 13. Test the engine and transfer switch safety devices. Correct and/or adjust as necessary.  | ○                                       |                            | ○  |                            | ○  |                            | ○                                      |                            | ○   |                            |
| 14. Initiate an automatic start and transfer of the unit to site load and exercise it for at least 1 hour looking for leaks, loose connections or components, and abnormal operating conditions. Correct as necessary. |   |                            |  |                            |  |                            | ○                                      |                            | ○   |                            |
| 15. Replace the engine accessory drive belts.  |   |                            |  |                            |  |                            |  |                            | ○   |                            |
| 16. Check gearbox oil level (if equipped).   | ○                                       |                            | ○  |                            | ○  |                            | ○                                      |                            | ○   |                            |
| 17. Change gearbox oil (if equipped).  |   |                            |  |                            |  |                            |  |                            | ○   |                            |



## Standby Generator Sets Service Schedule



| Maintenance Tasks   | Level 1                                 | Task Comp. (Date-Initials) | Level 2  | Task Comp. (Date-Initials) | Level 3                                    | Task Comp. (Date-Initials) | Level 4                                | Task Comp. (Date-Initials) | Level 5                                   | Task Comp. (Date-Initials) |
|---|---|----------------------------|--|----------------------------|--|----------------------------|--|----------------------------|---|----------------------------|
|   | Recommended to be done monthly/ 10 hrs. |                            | Required to be done 3 months/ Break-in 30 hrs. |                            | Required to be done Semi-annually/ 50 hrs. |                            | Required to be done Annually/ 100 hrs. |                            | Required to be done Bi-annually/ 250 hrs. |                            |
| 18. Start and exercise the unit at full rated load (use a load bank if the site load is not enough) for at least 2 hours looking for leaks, loose connections or components, and abnormal operating conditions. Correct as necessary. |   |                            |  |                            |  |                            |  |                            | ●   |                            |
| 19. Perform an engine oil analysis (send a sample to a lab for results). Change the engine oil and filters if the analysis results indicate this is required.   |   |                            |  |                            |  |                            | ●                                      |                            |   |                            |
| 20. Change the engine oil.  |   |                            | ●  |                            |  |                            | ●                                      |                            | ●   |                            |
| 21. Replace the engine oil filter(s).   |   |                            | ●  |                            |  |                            | ●                                      |                            | ●   |                            |
| 22. Replace engine spark plugs. Clean and re-gap or replace as necessary.   |   |                            |  |                            |  |                            | ●                                      |                            |   |                            |
| 23. Replace the engine air filter(s).   |   |                            |  |                            |  |                            |  |                            | ●   |                            |
| 24. Perform a 5 minute no-load operational run of the unit looking for any post service problems.   |   |                            | ●  |                            |  |                            |  |                            | ●   |                            |
| 25. Return the unit to standby setup for operation when required.   | ●                                       |                            | ●  |                            | ●  |                            | ●                                      |                            | ●   |                            |





### TROUBLESHOOTING GUIDE

| PROBLEM  | CAUSE   | CORRECTION  |
|--|---|---|
| Engine won't crank.                                    | <ol style="list-style-type: none"> <li>1. 15 amp fuse blown.</li> <li>2. Loose or corroded or defective battery cables.</li> <li>3. Defective starter contactor.</li> <li>4. Defective starter motor.</li> <li>5. Dead or Defective Battery.</li> <li>6. 5 amp fuse blown.</li> </ol>   | <ol style="list-style-type: none"> <li>1. Replace fuse.</li> <li>2. Tighten, clean or replace battery cables as necessary.</li> <li>3. Replace contactor.*</li> <li>4. Replace starter motor.*</li> <li>5. Remove, change or replace battery.</li> <li>6. Replace fuse.*</li> </ol>         |
| Engine cranks but won't start                          | <ol style="list-style-type: none"> <li>1. Out of fuel.</li> <li>2. Fuel solenoid (FS) is defective</li> <li>3. Open Wire #14A from Engine Control circuit board.</li> <li>4. Spark plugs defective.</li> <li>5. Door on tank not closed.</li> </ol>   | <ol style="list-style-type: none"> <li>1. Replenish fuel.</li> <li>2. Replace solenoid.*</li> <li>3. Reconnect wire.</li> <li>4. Clean, regap or replace plugs.</li> <li>5. Close door on tank.</li> </ol>  |
| Engine starts hard, runs rough.                        | <ol style="list-style-type: none"> <li>1. Flame arrestor (air cleaner) plugged or damaged.</li> <li>2. Plugged fuel line.</li> <li>3. Defective spark plugs.</li> <li>4. Fuel pressure incorrect.</li> </ol>  | <ol style="list-style-type: none"> <li>1. Clean or replace as needed.</li> <li>2. Unclog fuel line.</li> <li>3. Clean, regap or replace plugs.</li> <li>4. Confirm fuel pressure to regulator is as recommended in SPECIFICATIONS.</li> </ol>   |
| Engine starts then shuts down.                         | <ol style="list-style-type: none"> <li>1. Engine oil level is low.</li> <li>2. Engine is overheated.</li> <li>3. Defective Low Oil Pressure Switch</li> <li>4. Defective Coolant Temperature Switch</li> <li>5. Defective Control Module circuit board.</li> <li>6. Coolant Level is Low.</li> <li>7. Defective Low Coolant Level Switch</li> </ol> | <ol style="list-style-type: none"> <li>1. Check oil and add oil as needed.</li> <li>2. Check cooling system for leaks.</li> <li>3. Replace switch.*</li> <li>4. Replace switch.*</li> <li>5. Replace board.*</li> <li>6. Repair leak - Add coolant.</li> <li>7. Replace Switch.*</li> </ol> |
| AUTO/OFF/MANUAL Switch at OFF, engine continues to run | <ol style="list-style-type: none"> <li>1. Defective AUTO/OFF/MANUAL switch</li> <li>2. Open/disconnected wire #15A between AUTO/OFF/MANUAL switch and Control Module circuit board.</li> <li>3. Defective Control Module circuit board</li> </ol>   | <ol style="list-style-type: none"> <li>1. Replace switch.*</li> <li>2. Reconnect/close wire.</li> <li>3. Replace board.*</li> </ol>   |
| No AC output from generator.                           | <ol style="list-style-type: none"> <li>1. Check main line circuit breaker.</li> <li>2. Check circuit breaker &amp; fuses.</li> <li>3. Transfer switch set to NORMAL position</li> <li>4. Generator internal failure.</li> <li>5. Thermal circuit breaker open.</li> </ol>   | <ol style="list-style-type: none"> <li>1. Reset to ON or CLOSED.</li> <li>2. Reset and replace, if necessary.</li> <li>3. Set to GENERATOR position.</li> <li>4. *</li> <li>5. Auto-reset - Wait 5 min. and attempt restart.</li> </ol>   |

**\*Contact the nearest Authorized Dealer for assistance.**





# GROUP A

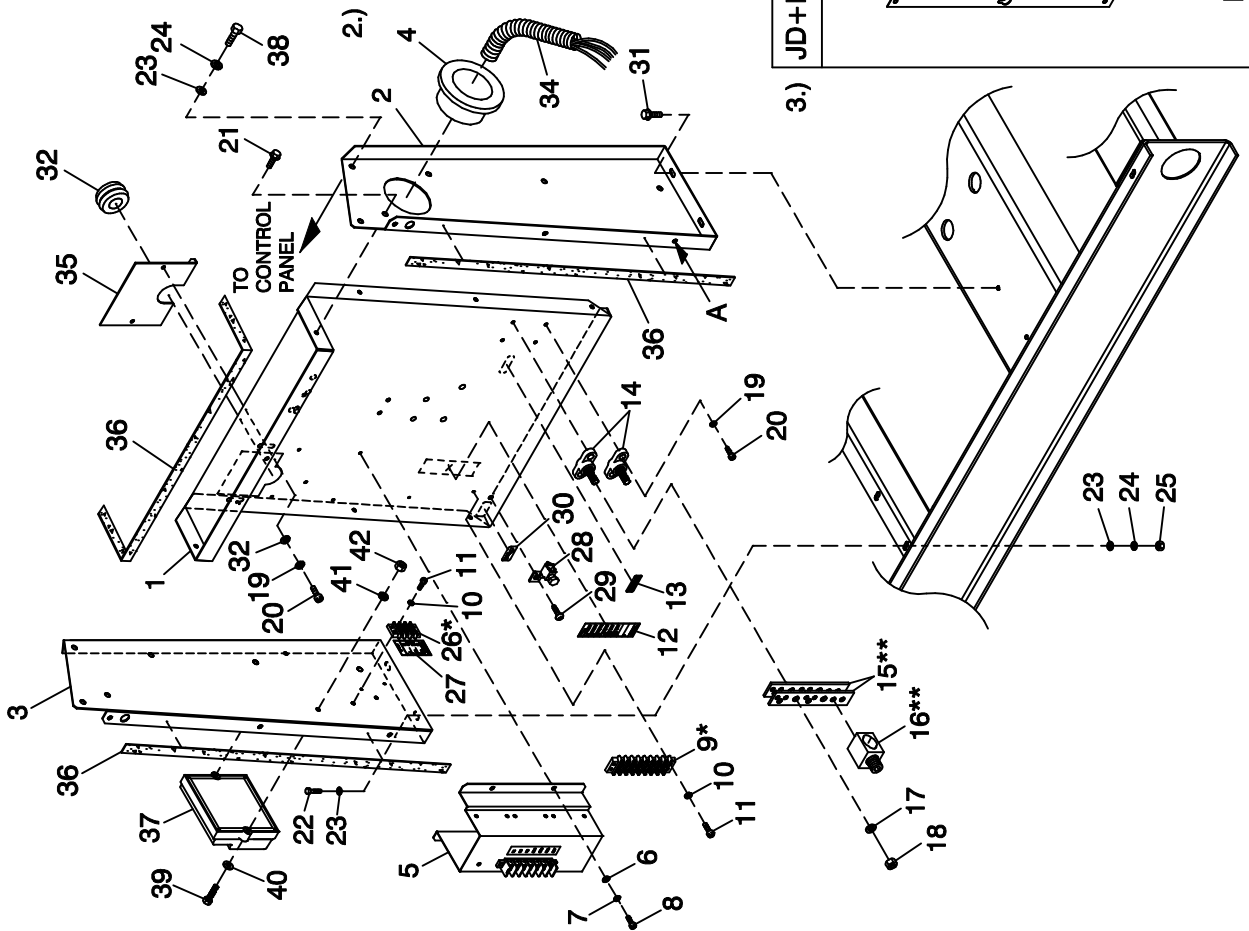
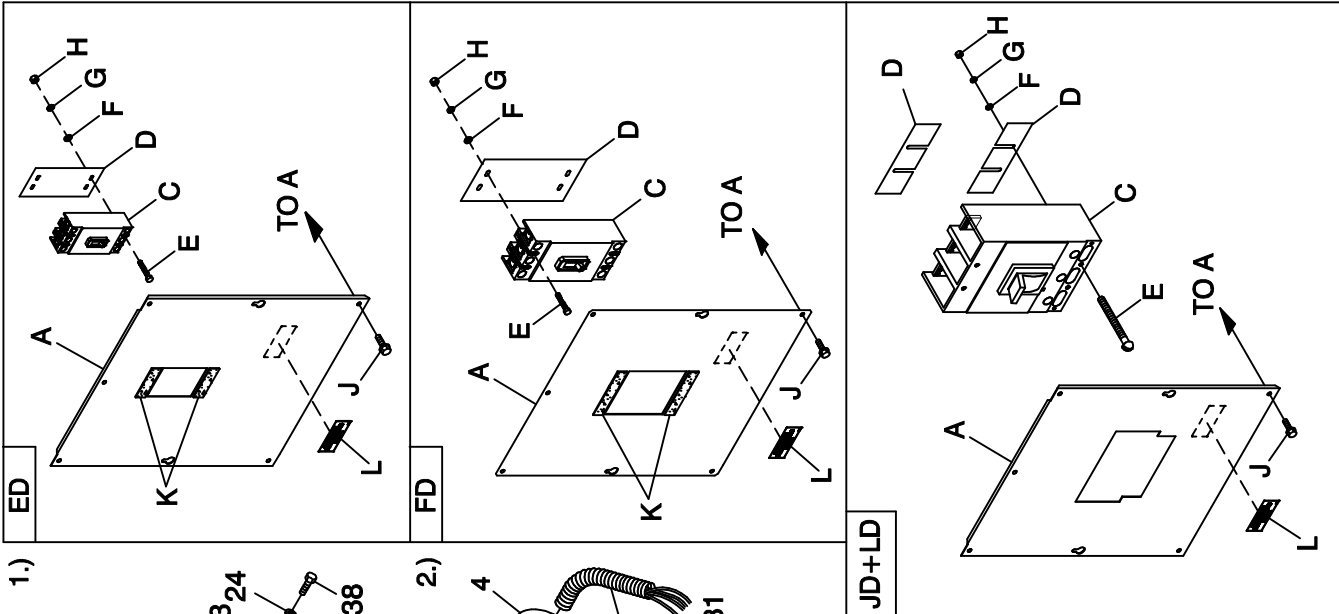

EXPLODED VIEW:  
CPL C3 H CONTROL  
DRAWING #: 0F3392D

EXPLODED VIEW: CPL C3 H CONTROL  
DRAWING #: 0F3392D

GROUP A

APPLICABLE TO:

| ITEM                       | PART #  | QTY. | DESCRIPTION                     |
|----------------------------|---------|------|---------------------------------|
| 1                          | 0F3137  | 1    | PAN CB CONN BOX                 |
| 2                          | 0F3135  | 1    | STAND RH CONTROL                |
| 3                          | 0F3136  | 1    | STAND LH CONTROL                |
| 4                          | 023484N | 1    | BUSHING SNAP SB-2.5-31          |
| 5                          | 0F4677  | 1    | ASSY PCB INTERFACE 1PH 240V     |
|                            | 0F6366B | -    | XFMR 240 TO 16V 6VA             |
|                            | 0F6366A | -    | XFMR 208 TO 16V 6VA             |
| 6                          | 043180  | 2    | WASHER FLAT M4                  |
| 7                          | 022264  | 2    | WASHER LOCK #8-M4               |
| 8                          | 0C3990  | 2    | SCREW PHTT M4-0.7 X 10 ZYC      |
| 9 (1)                      | 057701  | REF. | BLOCK TERM 20A 8 X 6 X 1100V    |
| 10                         | 022155  | 4    | WASHER LOCK #6                  |
| 11                         | 0C2428  | 4    | SCREW PHTT #6-32 X 1/2 ZYC      |
| 12                         | 0F3618  | 1    | DECAL CPL CUST CONN H CTRL      |
| 13                         | 0A9457  | 1    | DECAL NEUTRAL                   |
| 14                         | 057073  | 2    | JUNCTION BLOCK 3/8-16           |
| 15 (2)                     | 0D5466  | REF. | BUS BAR NEUTRAL BLOCK 390       |
| 16 (2)                     | 0A7822  | REF. | LUG SLDLSS 600/250-1/0 X 1/4-28 |
| 17                         | 022237  | 2    | WASHER LOCK 3/8                 |
| 18                         | 022241  | 2    | NUT HEX 3/8-16 STEEL            |
| 19                         | 049226  | 6    | WASHER LOCK M5                  |
| 20                         | 0C2266  | 6    | SCREW PHTT M5-0.8 X 16 ZYC      |
| 21                         | 0C2454  | 10   | SCREW THF M6-1 X 16 N WA Z/JS   |
| 22                         | 042568  | 4    | SCREW HHC M6-1.0 X 20 G8.8      |
| 23                         | 022473  | 12   | WASHER FLAT 1/4-M6 ZINC         |
| 24                         | 022097  | 8    | WASHER LOCK M6-1/4              |
| 25                         | 049813  | 4    | NUT HEX M6 X 1.0 G8 YEL CHR     |
| 26 (1)                     | 0D4698  | 1    | BLOCK TERM 20A 6 X 3 X 1100V    |
| 27                         | 0F4464  | 1    | DECAL CUST CONN 120V UTILITY    |
| 28                         | 025433  | 1    | LUG SLDLSS #6-14 X 13/64 CU     |
| 29                         | 024469  | 1    | SCREW HHTT #10-32 X 3/8 CZ      |
| 30                         | 067210A | 1    | DECAL GROUND LUG                |
| 31                         | 0D6029  | 4    | SCREW HHTT M6-1.0 X 16 ZYC      |
| 32                         | 051713  | 2    | WASHER FLAT M5                  |
| 33                         | 081008  | 1    | GROMMET 1.25 X .25 X .75        |
| 34                         | 077043J | 3    | CONDUIT FLEX 2.0" ID            |
| 35                         | 0F6156  | 1    | PLATE WIRE SNGL GALV            |
| 36                         | 029289  | 1    | TAPE ELEC 1/2 FOAM (AS REQ'D)   |
| 37 (3)                     | 0F3113  | REF  | ASSY PCB HSB CTRL IGN MODULE    |
| 38                         | 047411  | 4    | SCREW HHC M6-1.0 X 16 G8.8      |
| 39                         | 036943  | 2    | SCREW PPHM #10/32 X 2           |
| 40                         | 023897  | 2    | WASHER FLAT #10 ZINC            |
| 41                         | 022152  | 2    | WASHER LOCK #10                 |
| 42                         | 022158  | 2    | NUT HEX #10-32 STEEL            |
| 1) UL CIRCUIT BREAKER (ED) |         |      |                                 |
| A                          | 0F4810  | 1    | COVER ED CB STAND C3            |
| C                          | 0D5556  | 1    | CB 0090A 3P 480V S ED4 LL       |
|                            | 0D9693  | -    | CB 0125A 3P 480V S ED4 LL       |
| D                          | 0F0492  | 1    | INSULATOR CB S (ED-3P)          |
| E                          | 048927  | 4    | SCREW RHM #10-32 X 4-1/2        |
| F                          | 023897  | 4    | WASHER FLAT #10 ZINC            |
| G                          | 022152  | 4    | WASHER LOCK #10                 |
| H                          | 022158  | 4    | NUT HEX #10-32 STEEL            |
| J                          | 0C2454  | 7    | SCREW THF M6-1 X 16 N WA Z/JS   |
| K                          | 029289  | 1    | TAPE ELEC 1/2 FOAM (AS REQ'D)   |
| L                          | 0F1733  | 1    | DECAL CUSTOMER CONNECT INSIDE   |
| 2) UL CIRCUIT BREAKER (FD) |         |      |                                 |
| A                          | 0F4811  | 1    | COVER FD CB STAND C3            |
| C                          | 0D5574  | -    | CB 0200A 3P 600V S FD6 LL       |
|                            | 0D5576  | -    | CB 0250A 3P 600V S FD6 LL       |
| D                          | 0F0199  | 1    | INSULATOR CB FD FRAME 30MIL     |
| E                          | 065960  | 4    | SCREW SHC 1/4-20 X 4 G8.8 NZ    |
| F                          | 022473  | 4    | WASHER FLAT 1/4-M6 ZINC         |
| G                          | 022097  | 4    | WASHER LOCK M6-1/4              |
| H                          | 022127  | 4    | NUT HEX 1/4-20 STEEL            |
| J                          | 0C2454  | 7    | SCREW THF M6-1 X 16 N WA Z/JS   |
| K                          | 029289  | 1    | TAPE ELEC 1/2 FOAM (AS REQ'D)   |
| L                          | 0F1733  | 1    | DECAL CUSTOMER CONNECT INSIDE   |

| ITEM                          | PART # | QTY. | DESCRIPTION                   |
|-------------------------------|--------|------|-------------------------------|
| 3) UL CIRCUIT BREAKER (JD+LD) |        |      |                               |
| A                             | 0F4812 | 1    | COVER JD/LD CB STAND C3       |
| C                             | 0D5577 | 1    | CB 0300A 3P 600V S JD6 LL     |
| D                             | 0F2353 | 2    | INSULATOR CIRCUIT BR. JD/LD   |
| E                             | 022770 | 4    | SCREW RHM 1/4-20 X 3          |
| F                             | 022473 | 4    | WASHER FLAT 1/4-M6 ZINC       |
| G                             | 022097 | 4    | WASHER LOCK M6-1/4            |
| H                             | 022127 | 4    | NUT HEX 1/4-20 STEEL          |
| J                             | 0C2454 | 7    | SCREW THF M6-1 X 16 N WA Z/JS |
| K                             | 029289 | 1    | TAPE ELEC 1/2 FOAM (AS REQ'D) |
| L                             | 0F1733 | 1    | DECAL CUSTOMER CONNECT INSIDE |

(1) ITEM INCLUDED WITH HARNESS

(2) ITEM INCLUDED WITH 0D5464B

(3) ITEM IS PART OF 9R.

GROUP A

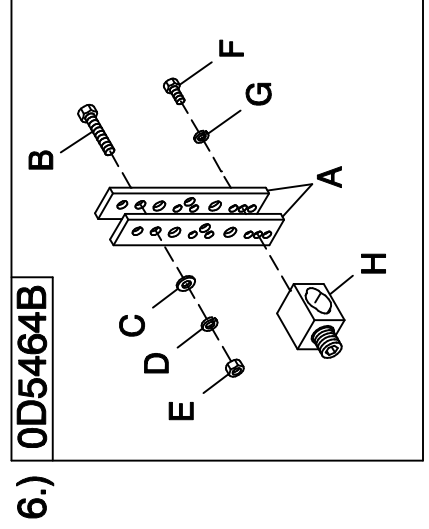
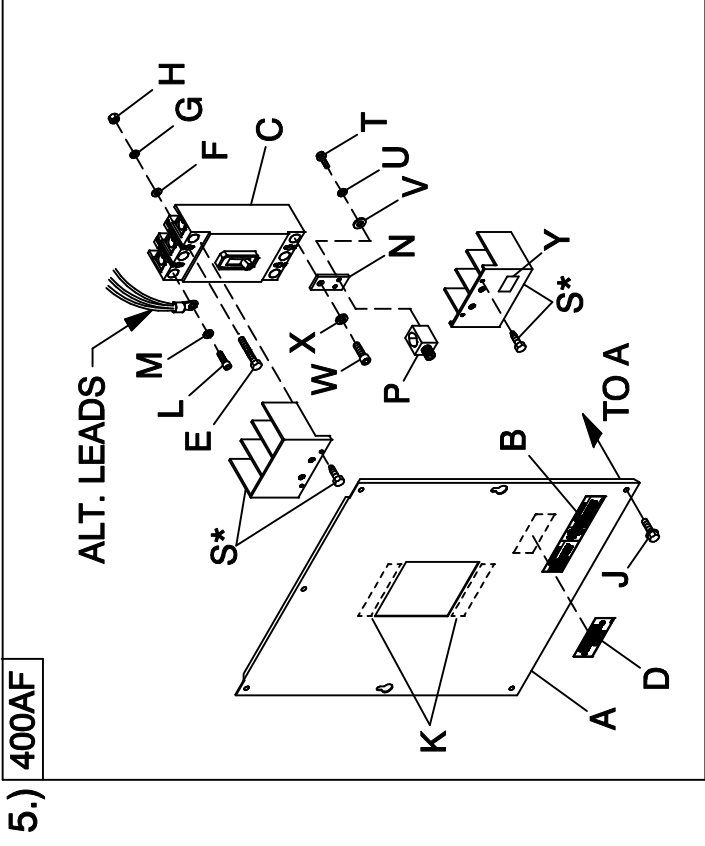
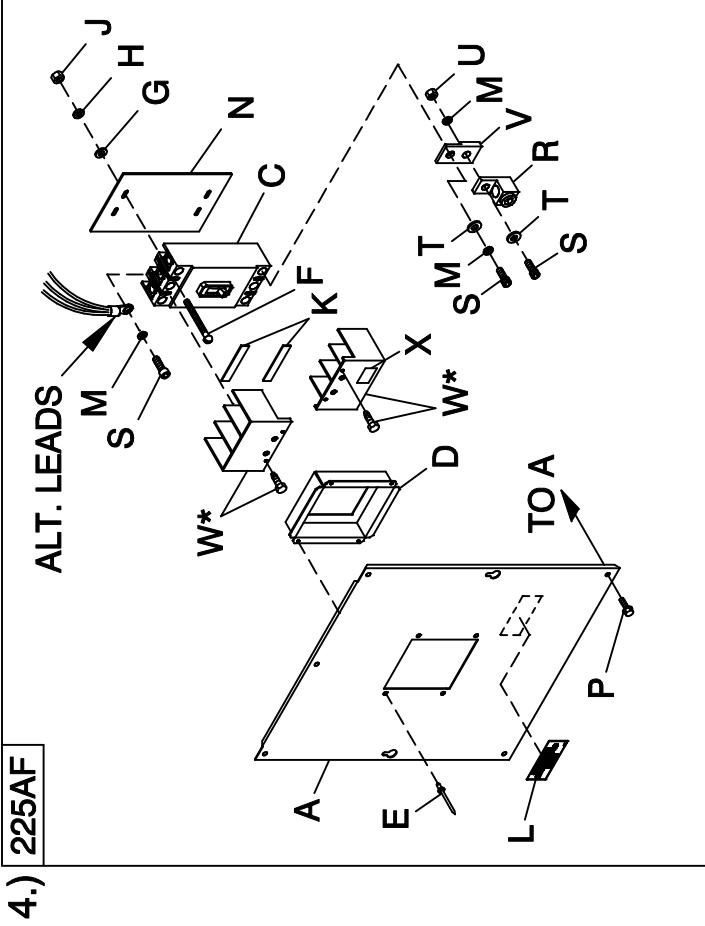

APPLICABLE TO:

| ITEM  | PART #   | QTY. | DESCRIPTION                     |
|-------|----------|------|---------------------------------|
| 4.)   |          |      | UL CIRCUIT BREAKER (225AF)      |
| A     | 0F8453   | 1    | COVER CB C3 225AF               |
| C     | 0F4165\$ | REF  | CIRCUIT BREAKERS 200A FRAME     |
| D     | 0F4186   | 1    | COVER CB DISH 225AF             |
| E     | 036261   | 4    | RIVET POP .125 X .275 SS        |
| F     | 053640   | 4    | SCREW RHM #8-32 X 3-1/4         |
| G     | 038150   | 4    | WASHER FLAT #8 ZINC             |
| H     | 022264   | 4    | WASHER LOCK #8-M4               |
| J     | 022471   | 4    | NUT HEX #8-32 STEEL             |
| K     | 029289   | 2    | TAPE ELEC 1/2 FOAM              |
| L     | 0F1733   | 1    | DECAL CUSTOMER CONNECT INSIDE   |
| M     | 022129   | 9    | WASHER LOCK M8-5/16             |
| N     | 0F8432   | 1    | INSULATOR CB 225AF              |
| P     | 0C2454   | 7    | SCREW THF M6-1 X 16 N WA Z/JS   |
| R     | 0F8451   | 3    | LUG SLDLSS 300 MCM-6 AL/CU      |
| S     | 049897   | 9    | SCREW SHC M8-1.25 X 20 G8       |
| T     | 022145   | 6    | WASHER FLAT 5/16-M8 ZINC        |
| U     | 045771   | 3    | NUT HEX M8-1.25 G8 CLEAR ZINC   |
| V     | 0F8843   | 3    | BUS BAR 200A LUG ADAPTOR        |
| W*    | W/CB     | 2    | TERMINAL COVER CB               |
| X     | 0G3259   | 1    | DECAL TERMINAL SHOCK HZD BI     |
| 5.)   |          |      | UL CIRCUIT BREAKER (400AF)      |
| A     | 0F8454   | 1    | COVER CB C3 400AF               |
| C     | 0F4166\$ | REF  | CIRCUIT BREAKERS 400A FRAME     |
| D     | 0F1733   | 1    | DECAL CUSTOMER CONNECT INSIDE   |
| E     | 042419   | 4    | SCREW RHM 10-32 X 4             |
| F     | 023897   | 4    | WASHER FLAT #10 ZINC            |
| G     | 022152   | 4    | WASHER LOCK #10                 |
| H     | 022158   | 4    | NUT HEX #10-32 STEEL            |
| J     | 0C2454   | 7    | SCREW THF M6-1 X 16 N WA Z/JS   |
| K     | 029289   | 1    | TAPE ELEC 1/2 FOAM              |
| L     | 052647   | 6    | SCREW SHC M10-1.5 X 25 G12.9    |
| M     | 046526   | 6    | WASHER LOCK M10                 |
| N     | W/CB     | 3    | BUS BAR CB ADAPTER 225-400 A    |
| P     | 0A7822   | 3    | LUG SLDLSS 600/250-1/0 X 1/4-28 |
| S (1) | W/CB     | 2    | TERM COVER CB                   |
| T     | 023334   | 6    | SCREW HHC 1/4-28 X 1/2 G5       |
| U     | 022097   | 6    | WASHER LOCK M6-1/4              |
| V     | 022473   | 6    | WASHER FLAT 1/4-M6 ZINC         |
| W     | W/CB     | 2/3  | SCREW SHC M10-1.5 x 25 G12.9    |
| X     | W/CB     | 2/3  | WASHER LOCK M10                 |
| Y     | 0G3259   | 1    | DECAL TERMINAL SHOCK HZD BI     |
| 6.)   |          |      | NEUTRAL BLOCK 390 / 200-400A    |
| A     | 0D5466   | 2    | BUS BAR NEUTRAL BLOCK 390       |
| B     | 039287   | 1    | SCREW HHC M8-1.25 X 45 G8.8 FT  |
| C     | 022145   | 1    | WASHER FLAT 5/16-M8 ZINC        |
| D     | 022129   | 1    | WASHER LOCK M8-5/16             |
| E     | 045771   | 1    | NUT HEX M8-1.25 G8 YEL CHR      |
| F     | 045335   | 2    | SCREW HHC 1/4-28 X 3/4 G5       |
| G     | 022097   | 2    | WASHER LOCK M6-1/4              |
| H     | 0A7822   | 1    | LUG SLDLSS 600/250-1/0X1/4-28   |

(1) HARDWARE FOR MTG. CB TERMINAL COVERS IS SUPPLIED WITH CIRCUIT BREAKERS.

(2) 2/3 QTY. 2 POLE &amp; 3 POLE CB.

# GROUP A

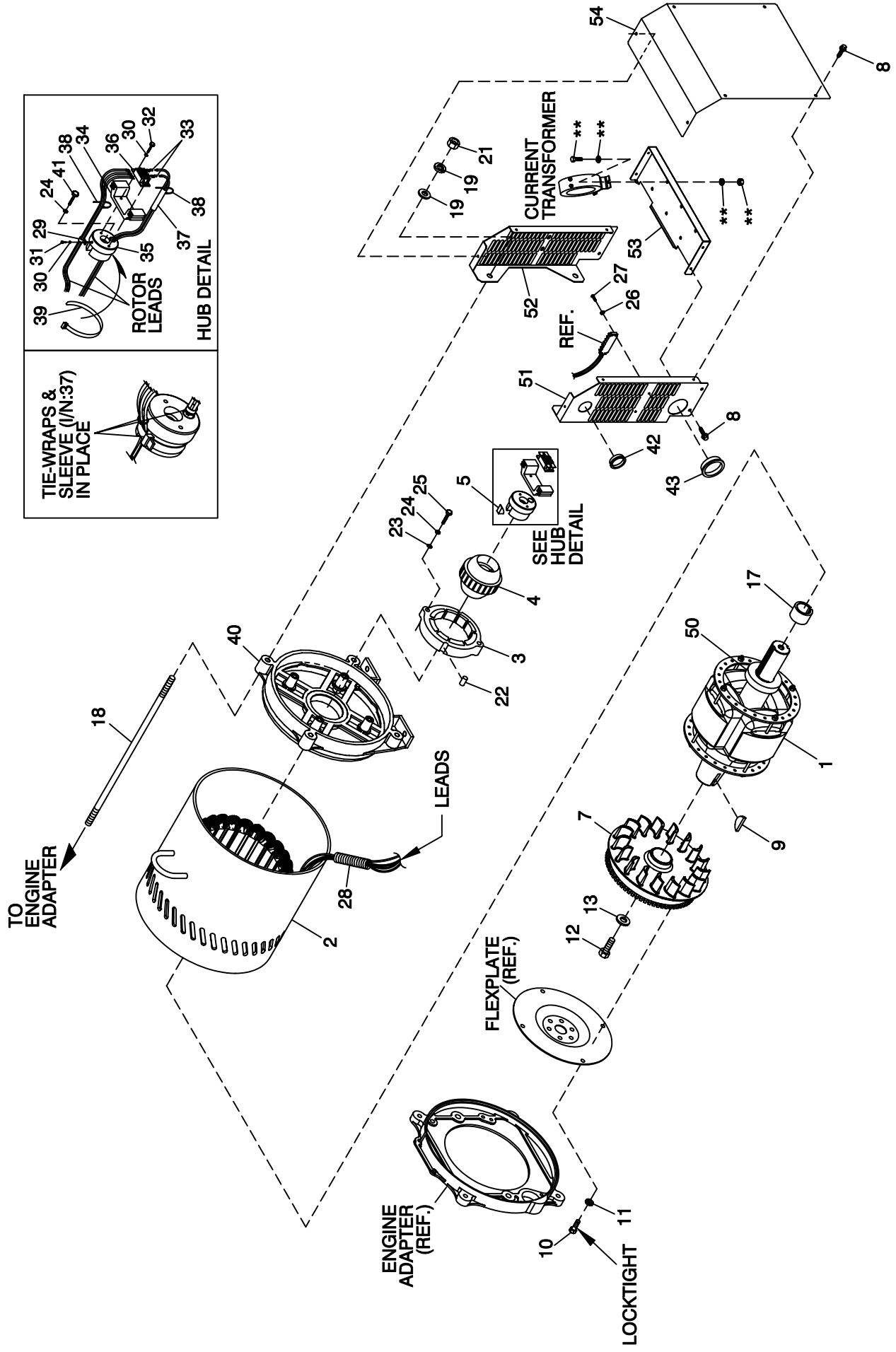



EXPLODED VIEW: CPL ALTERNATOR BRUSHLESS 70KW 4-POLE  
DRAWING #: 0F5924

GROUP A

APPLICABLE TO:

| ITEM | PART #     | QTY. | DESCRIPTION                      |
|------|------------|------|----------------------------------|
| 1    | 0F3182     | 1    | ROTOR 390 70AB3 CPL              |
|      | 0F6194     | 1    | RTR 390 70KB3 CPL                |
| 2    | 0F3183     | 1    | STATOR 390 70AB3 CPL             |
|      | 0F6195     | 1    | STR 390 70KB3 CPL                |
|      | 0F6203     | 1    | STR 390 70GB3 CPL                |
| 3    | 068405C    | 1    | EXITER FIELD 2" LG SPD CONN      |
| 4    | 087272     | 1    | ASSY EXCITER 2.00" STK           |
| 5    | 072878     | 1    | KEY SQ 3/8 X 3-1/4 STEEL         |
| 6    | 0C9708     | REF  | INSTR HYPOT TEST (NOT SHOWN)     |
| 7    | 0F3726B    | 1    | ASSY FLYWHEEL CPL                |
| 8    | 0C2454     | 10   | SCREW THF M6-1 X 16 N WA Z/JS    |
| 9    | 023454     | 1    | KEY WOODRUFF #E                  |
| 10   | 0F8408     | 4    | SCREW HHC M10-1.50 X 16 G10.9    |
| 11   | 046526     | 4    | WASHER LOCK M10                  |
| 12   | 0A2601     | 1    | SCREW HHC M16-2.0 X 45 G8.8      |
| 13   | 0A2602     | 1    | WASHER FLAT .688 ID X 3.25 OD    |
| 14   | 022473     | 9    | WASHER FLAT 1/4-M6 ZINC          |
| 15   | 022097     | 9    | WASHER LOCK M6-1/4               |
| 16   | 047411     | 9    | SCREW HHC M6-1.0 X 16 G8.8       |
| 17   | 092950     | 1    | COLLAR SLIP FIT 390 MM           |
| 18   | 04576100CJ | 4    | STUD M14-2.0 X 650 G5 ZINC       |
| 19   | 052646     | 4    | WASHER FLAT M14                  |
| 20   | 043123     | 4    | WASHER LOCK M14                  |
| 21   | 051779     | 4    | NUT HEX M14-2.0 G8 YEL CHR       |
| 22   | 022392     | 2    | PIN DOWEL 1/2 X 1-1/4            |
| 23   | 052259     | 2    | WASHER FLAT M12                  |
| 24   | 051769     | 3    | WASHER LOCK M12                  |
| 25   | 0E7230     | 3    | SCREW HHC M12-1.75 X 80 G10.9    |
| 26   | 0C2428     | 2    | SCREW PHTT #6-32 X 1/2 ZYC       |
| 27   | 022155     | 2    | WASHER LOCK #6                   |
| 28   | 077043F    | 1    | CONDUIT FLEX 1.25" ID            |
| 29   | 020151     | 1    | CLAMP VINYL .312 X .203 Z        |
| 30   | 023365     | 3    | WASHER SHAKEPROOF INT #8         |
| 31   | 033133     | 1    | SCREW HHM #8-32 X 3/8            |
| 32   | 033143     | 2    | SCREW HHM #8-32 X 7/8            |
| 33   | 086032     | 2    | LUG RT-ANG #10/10-12             |
| 34   | 090063     | 1    | BRIDGE SUPPORT DIODE 15"         |
| 35   | 090064     | 1    | CAP END ROTOR 390MM              |
| 36   | 090152     | 1    | ASSY BRIDGE RECTIFIER            |
| 37   | 022661L    | 1    | SLEEVING UL #0 .330 ID (3" LG)   |
| 38   | 028739A    | 2    | TIE WRAP UL 3.9" X .10" BLK      |
| 39   | 085662D    | 1    | TIE WRAP UL 17.7 X .35 BLK HT    |
| 40   | 068113     | 1    | CARRIER REAR BRG 15" (BRUSHLESS) |
| 41   | 068406     | 1    | SCREW HHC M12-1.75 X 60 G10.9    |
| 42   | 023484K    | 1    | BUSHING SNAP SB-1750-22          |
| 43   | 023484N    | 1    | BUSHING SNAP SB-2.5-31           |
| 50*  | 052624     | 1    | BEARING BALL 6212 SEALED         |
| 51   | 0F3518     | 1    | SIDE LH EXCITER SHIELD           |
| 52   | 0F3517     | 1    | SIDE RH EXCITER SHIELD           |
| 53   | 0F3519     | 1    | BOTTOM EXCITER SHIELD            |
| 54   | 0F3520     | 1    | REAR COVER EXCITER SHLD          |

\* ROTOR REPLACEMENT PARTS.

\*\* PARTS INCLUDED WITH TRANSFORMER.

# GROUP C

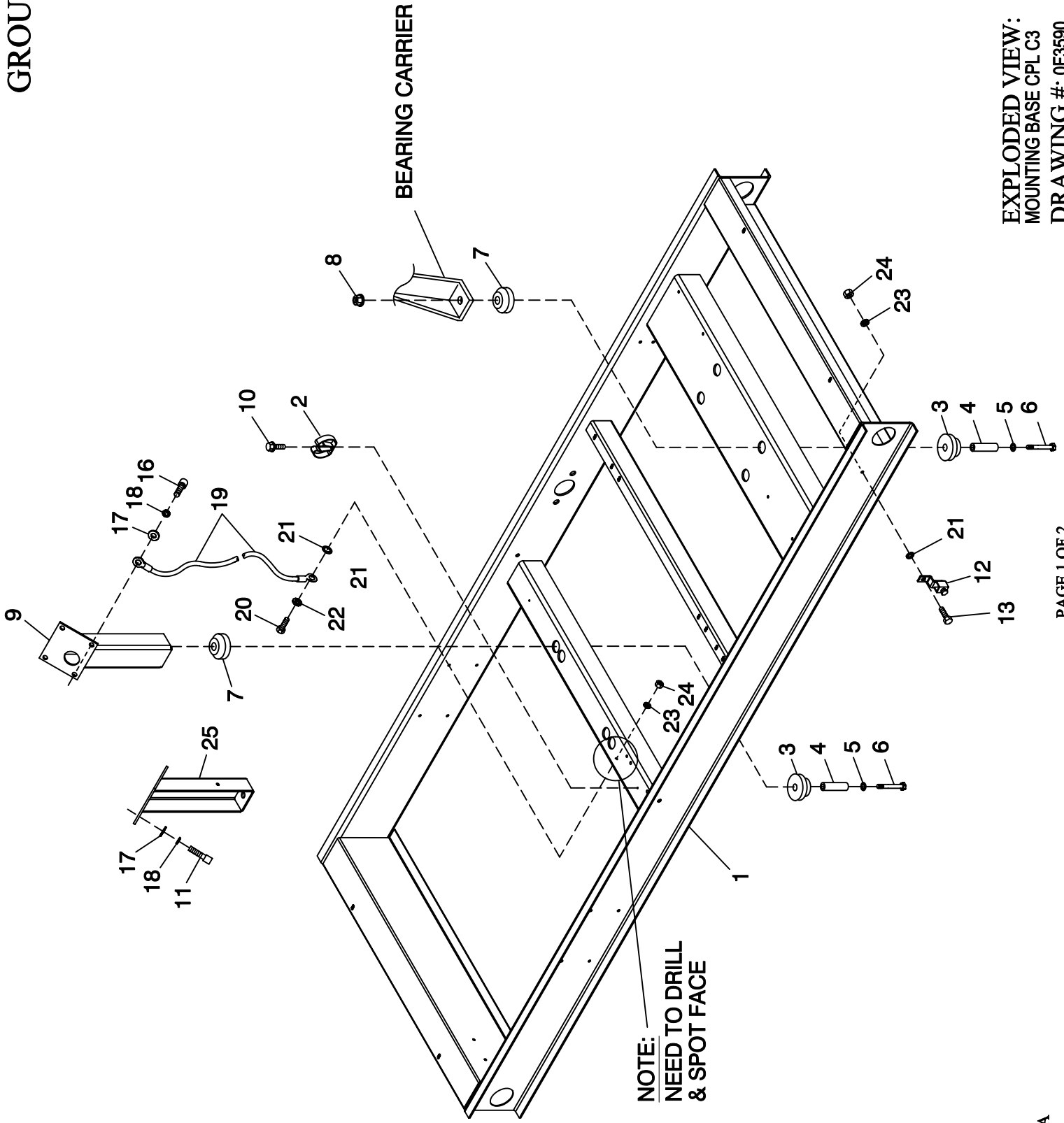

BEARING CARRIER

NOTE:  
NEED TO DRILL  
& SPOT FACE

EXPLODED VIEW:  
MOUNTING BASE CPL C3  
DRAWING #: 0F3590

REVISION: G-8018-A  
DATE: 4/27/06

## EXPLODED VIEW: MOUNTING BASE CPL C3

DRAWING #: 0F3590

GROUP C

APPLICABLE TO:

| ITEM | PART #     | QTY. | DESCRIPTION                         |
|------|------------|------|-------------------------------------|
| 1    | 0F3150     | 1    | BASE CP 6.8L70KW/5.4L 55KW DD       |
| 2    | 065852     | 1    | SPRING CLIP HOLDER .37-.62          |
| 3    | 052252     | 4    | DAMPENER VIBRATION                  |
| 4    | 052257     | 4    | SPACER .49 X .62 X 1.87 PWDR/ZINC   |
| 5    | 052259     | 4    | WASHER FLAT M12                     |
| 6    | 055597     | 4    | SCREW HHC M12-1.75 X 85 G8.8        |
| 7    | 052251A    | 4    | DAMPENER VIBRATION 50 WHITE         |
| 8    | 052860     | 4    | NUT LOCKING M12-1.75                |
| 9    | 0F2895     | 1    | SUPPORT ENG 5.4L LH/RH 6.8L RH      |
| 10   | 045764     | 1    | SCREW HHTT M4-0.7 X 8 BP            |
| 11   | 057192     | 4    | SCREW SHC M10-1.5 X 30 G12.9 (5.4L) |
|      | 090502     | 4    | SCREW SHC M10-1.5 X 60 G12.9 (6.8L) |
| 12   | 061383     | 1    | LUG SOLDERLESS 3/0-#4 X 13/32 CU    |
| 13   | 043107     | 1    | SCREW HHC M8-1.25 X 25 G8.8         |
| 16   | 057192     | 4    | SCREW SHC M10-1.5 X 30 G12.9        |
| 17   | 022131     | 8    | WASHER FLAT 3/8-M10 ZINC            |
| 18   | 046526     | 8    | WASHER LOCK M10                     |
| 19   | 0536210360 | 1    | WIRE ASSEM #4GA GRD                 |
| 20   | 042909     | 1    | SCREW HHC M8-1.25 X 30 G8.8         |
| 21   | 022261     | 2    | WASHER SHAKEPROOF INT 3/8           |
| 22   | 022129     | 1    | WASHER LOCK M8-5/16                 |
| 23   | 022145     | 2    | WASHER FLAT 5/16-M8 ZINC            |
| 24   | 045771     | 2    | NUT HEX M8-1.25 G8 YEL CHR          |
| 25   | 0F2910     | 1    | SUPPORT, ENGINE (6.8L LH SIDE)      |
|      | 0F2895     | 1    | SUPPORT ENG (5.4L LH SIDE)          |

# GROUP C

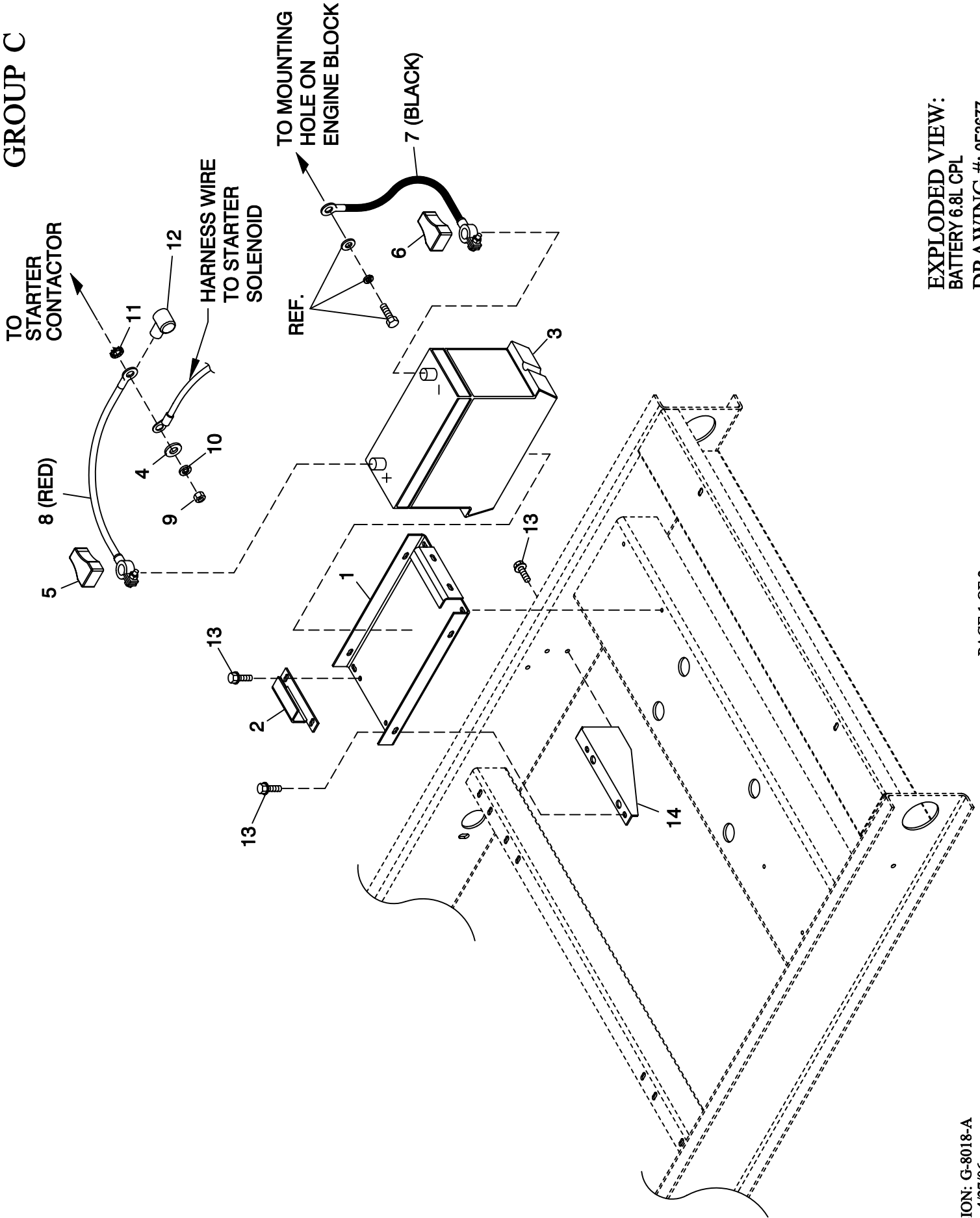

EXPLODED VIEW:  
BATTERY 6.8L CPL  
DRAWING #: 0F3677

**EXPLODED VIEW: BATTERY 6.8L CPL**

**DRAWING #: 0F3677**

**GROUP C**

**APPLICABLE TO:**

| <b>ITEM</b> | <b>PART #</b> | <b>QTY.</b> | <b>DESCRIPTION</b>             |
|-------------|---------------|-------------|--------------------------------|
| 1           | 0F3408        | 1           | TRAY BATTERY                   |
| 2           | 0F3411        | 1           | STRAP BATTERY RETAINMENT       |
| 3           | 058208        | 1           | BATT 12VDC 24F 625             |
| 4           | 022131        | 1           | WASHER FLAT 3/8-M10 ZINC       |
| 5           | 050331A       | 1           | BATT POST COVER RED +          |
| 6           | 050331        | 1           | BATT POST COVER BLK -          |
| 7           | 038805T       | 1           | CABLE BATT BLK #1 X 40.00      |
| 8           | 038804Y       | 1           | CABLE BATT RED #1 X 35.00      |
| 9           | 045771        | 1           | NUT HEX M8-1.25 G8 YEL CHR     |
| 10          | 022129        | 1           | WASHER LOCK M8-5/16            |
| 11          | 027482        | 1           | WASHER SHAKEPROOF EXT 5/16 STL |
| 12          | 075763        | 1           | BOOT BATTERY CABLE             |
| 13          | 0C2454        | 8           | SCREW THF M6-1X16 N WA Z/JS    |
| 14          | 0F3409        | 1           | SUPPORT BATTERY TRAY           |

# GROUP D

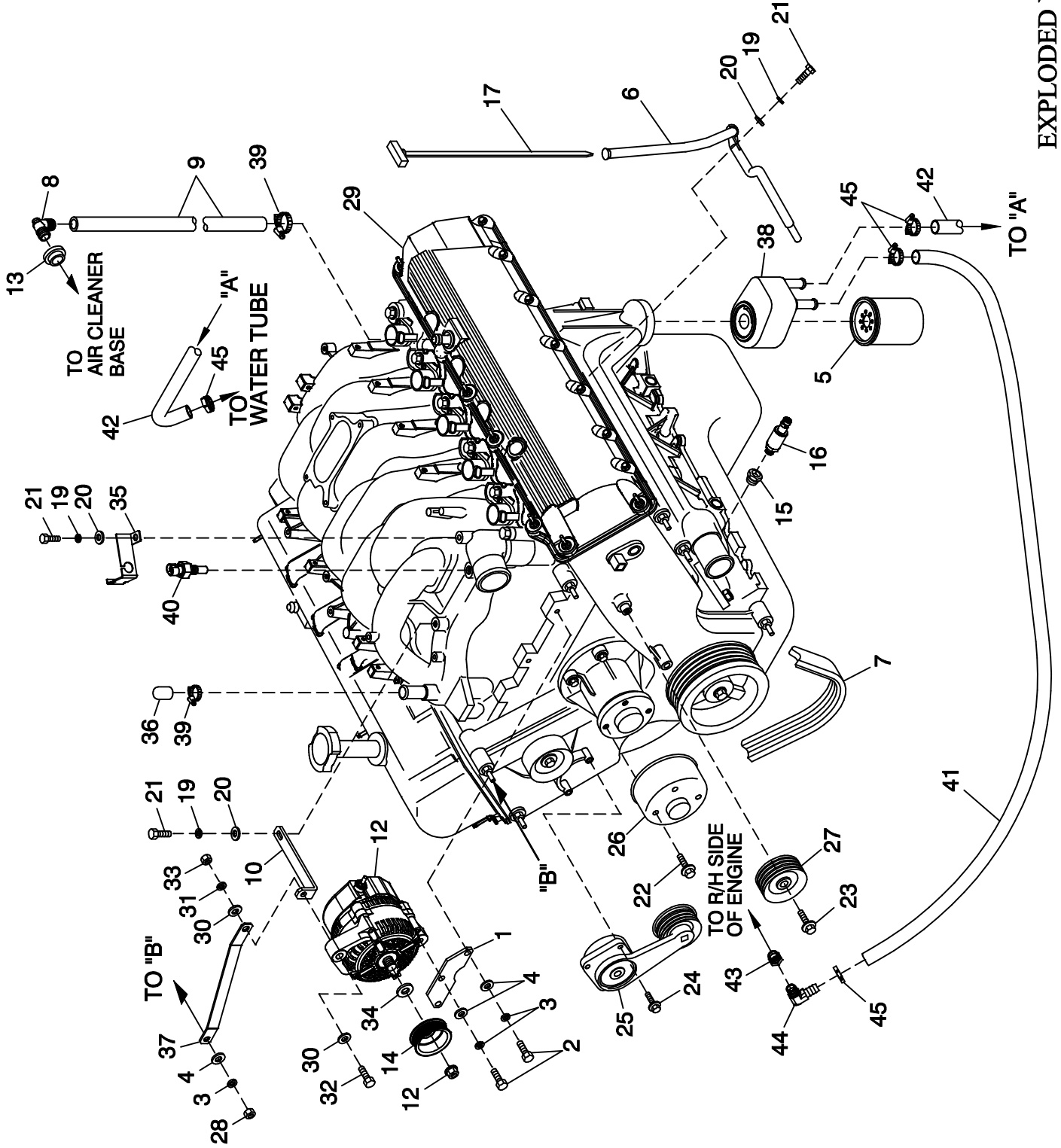

EXPLODED VIEW:  
ENGINE COMMON PARTS L/H SIDE (6.8L CPL)  
DRAWING #: 0F3016

## EXPLODED VIEW: ENGINE COMMON PARTS L/H SIDE (6.8L CPL)

DRAWING #: 0F3016

GROUP D

APPLICABLE TO:

| ITEM   | PART #  | QTY. | DESCRIPTION                                     |
|--------|---------|------|---|
| 1      | 0F3017  | 1    | BRACKET,D.C. ALTERNATOR LOWER                   |
| 2      | 039253  | 3    | SCREW HHC M8-1.25 X 20 G8.8                     |
| 3      | 022129  | 4    | WASHER LOCK M8-5/16                             |
| 4      | 022145  | 4    | WASHER FLAT 5/16-M8 ZINC                        |
| (2) 5  | 0D5419  | REF  | OIL FILTER, FORD V-10 ENGINE                    |
| 6      | 0D7055  | 1    | DIPSTICK TUBE, FORD 6.8L                        |
| 7      | 0D3488G | 1    | BELT SERPENTINE (65.0" LG) (1800 RPM)           |
|        | 0D3488J | 1    | BELT SERPENTINE (65.3" LG) (2300 RPM)           |
|        | 0D3488  | 1    | BELT SERPENTINE (67.16" LG) (3000 RPM)          |
|        | 0D3488K | 1    | SERPENTINE BELT (68.3" LG) (3600 RPM)           |
| 8      | 057795A | 1    | BARBED EL 90 3/4 PLASTIC                        |
| 9      | 059057  | 1    | HOSE 3/4 ID SAE-30R2 (16.75"LG)                 |
| 10     | 0F3287  | 1    | BRACKET DC ALTERNATOR UPPER                     |
| 11     | 0F5990  | 1    | HARN ENG 6.8L H-100 (NOT SHOWN)                 |
|        | 0F4419  | 1    | HARN ENG 6.8L G-100 (NOT SHOWN)                 |
|        | 0F9786  | 1    | HARN ENG 6.8L G-100 MQT 208V (NOT SHOWN)        |
| 12     | 0E9868A | 1    | ALTERNATOR DC W/OUT PULLEY                      |
| 13     | 057796  | 1    | GROMMET   |
| 14     | 0F3216  | 1    | PULLEY 80 OD DC ALTERNATOR (1800 RPM)           |
|        | 0F3216A | 1    | PULLEY 102 OD DC ALTERNATOR (2300 RPM)          |
|        | 0F3216C | 1    | PULLEY 132 OD DC ALTERNATOR (3000 RPM)          |
|        | 0F3216D | 1    | PULLEY 160 OD DC ALTERNATOR (3600 RPM)          |
| 15     | 055476  | 1    | BUSHING REDUCER 3/8 TO 1/8 GAL                  |
| 16     | 0F4612  | 1    | SENDER OIL PRESSURE 1/8" NPT                    |
| 17     | 0D6658  | 1    | DIPSTICK 6.8L FORD                              |
| (1) 18 | 029333A | 2    | TIE WRAP UL 7.4" X .19" BLK (NOT SHOWN)         |
| 19     | 022097  | 3    | WASHER LOCK M6-1/4                              |
| 20     | 022473  | 3    | WASHER FLAT 1/4 ZINC                            |
| 21     | 042568  | 3    | SCREW HHC M6-1.0 X 20 G8.8                      |
| 22     | 0D8027  | 4    | BOLT WATER PUMP PULLEY                          |
| 23     | 0D8025  | 1    | BOLT GROOVED IDLER PULLEY                       |
| 24     | 0D8026  | 3    | BOLT BELT TENSIONER                             |
| 25     | 0D8030  | 1    | TENSIONER ENG. AUTOMATIC BELT                   |
| 26     | 0F2846  | 1    | PULLEY WATER PUMP FORD (1800RPM UNITS)          |
|        | 0D8029  | 1    | PULLEY ENGINE WATER PUMP (2-POLE & GEAR BOX)    |
| 27     | 0D8028  | 1    | PULLEY GROOVED ENGINE IDLER                     |
| 28     | 045771  | 1    | NUT HEX M8-1.25 G8 YEL CHR                      |
| 29     | 0D3454  | 1    | ENGINE 6.8L FORD (V-10)                         |
| 30     | 022131  | 2    | WASHER FLAT 3/8-M10 ZINC                        |
| 31     | 046526  | 1    | WASHER LOCK M10                                 |
| 32     | 064416  | 1    | SCREW HHC M10-1.5 X 45 G8.8 FT                  |
| 33     | 045772  | 1    | NUT HEX M10-1.5 G8 YEL CHR                      |
| 34     | 0F3217  | 1    | SPACER DC ALTERNATOR PULLEY                     |
| 35     | 0F2776A | 1    | BRACKET SIGNAL CONDITIONER                      |
| 36     | 0F6151  | 1    | CAP RUBBER                                      |
| 37     | 0F4308  | 1    | BRACKET DC ALT STABILIZER                       |
| 38     | 0F3158  | 1    | OIL COOLER FORD (150KW 3600RPM)                 |
| 39     | 057823  | 2    | CLAMP HOSE #10 .56-1.06                         |
| 40     | 0E0502  | 1    | TEMPERATURE SENDER DELPHI                       |
| 41     | 0G0866  | 1    | HOSE OIL COOLER PREFORMED 3/4 (150KW 3600RPM)   |
| 42     | 0F4301  | 1    | HOSE OIL COOLER (150KW 3600RPM)                 |
| 43     | 0F4355  | 1    | ADAPTOR 1/2" NPT - 3/8" NPT (150KW 3600RPM)     |
| 44     | 0G0153  | 1    | BARBED EL 90 1/2 NPT X 3/4 HOSE (150KW 3600RPM) |
| 45     | 057823  | 4    | CLAMP HOSE #10 .56-1.06 (150KW 3600RPM)         |

(1) NOTE: I/N 18 IS FOR HOLDING SENSOR TO I/N 35.

(2) I/N 5 PART OF I/N 29.

# GROUP D

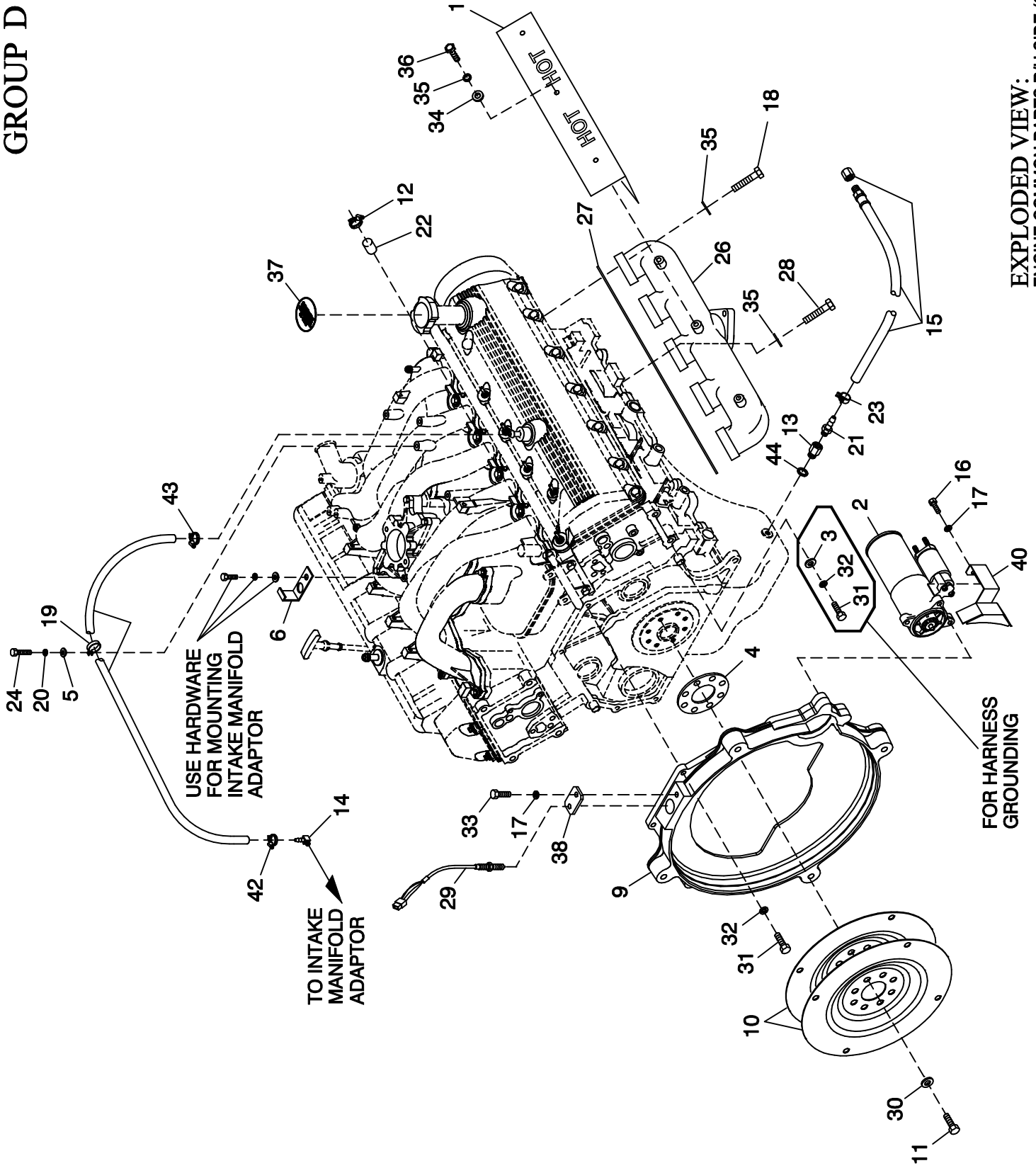

EXPLODED VIEW:  
ENGINE COMMON PARTS R/H SIDE (6.8L CPL)  
DRAWING #: 0F3058



## EXPLODED VIEW: ENGINE COMMON PARTS R/H SIDE (6.8L CPL)

DRAWING #: 0F3058

GROUP D

APPLICABLE TO:

| ITEM  | PART #  | QTY. | DESCRIPTION   |
|-------|---------|------|---|
| 1     | 0D5623  | 2    | HEAT SHIELD EXHAUST                                 |
| 2     | 0D5418  | 1    | STARTER MOTOR FORD V-10 ENGINE                      |
| 3     | 022131  | 1    | WASHER FLAT 3/8-M10 ZINC                            |
| 4     | 0F3514  | 1    | SPACER FLEXPLATE 5.4L/6.8L (1800 RPM UNITS ONLY)    |
| 5     | 022473  | 1    | WASHER FLAT 1/4-M6 ZINC                             |
| 6     | 0F2776A | 1    | BRACKET SIGNAL CONDITIONER                          |
| 7 *   | 029333A | 1    | TIE WRAP UL 7.4" X .19" BLK (NOT SHOWN)             |
| 8     | 057772  | 1    | WASHER NYLON .565                                   |
| 9     | 0F2929  | 1    | ENGINE ADAPTER 5.4L/6.8L                            |
| 10    | 0F3903C | 1    | FLEX PLATE 2 POLE 5.4L & 6.8L (1800 RPM UNITS ONLY) |
|       | 0F3903C | 2    | FLEX PLATE 2 POLE 5.4L & 6.8L (3600 RPM UNITS ONLY) |
| 11 ** | 0D5417  | REF. | SCREW HHC M10-1.0 X 25 G10.9                        |
| 12    | 057823  | 1    | CLAMP HOSE #10 .56 - 1.06 (1800 RPM UNITS ONLY)     |
| 13    | 057765  | 1    | ADAPTER M14-1.50 X 3/8 NPT                          |
| 14    | 053660  | 1    | BARBED STR 1/4 NPT X 5/8                            |
| 15    | 069860E | 1    | HOSE DRAIN ASSY 28"                                 |
| 16    | 042909  | 3    | SCREW HHC M8-1.25 X 30 G8.8                         |
| 17    | 022129  | 4    | WASHER LOCK M8-5/16                                 |
| 18    | 0D9913  | 18   | SCREW SHC M8-1.25 X 35 SS                           |
| 19    | 055934M | 1    | CLAMP VINYL .75 X .343 Z                            |
| 20    | 022097  | 1    | WASHER LOCK M6-1/4                                  |
| 21    | 055596  | 1    | BARBED STR 3/8 NPT X 3/8                            |
| 22    | 077996  | 1    | CAP HOSE (1800 RPM UNITS ONLY)                      |
| 23    | 048031J | 1    | HOSE CLAMP BAND 5/8"                                |
| 24    | 047411  | 1    | SCREW HHC M6-1.0 X 16 G8.8                          |
| 25    | 0G0321  | 1    | HOSE COOL 5/8" ID 250#WP (14")                      |
| 26    | 0D3808  | 2    | EXH MANIFOLD MACH 6.8L V-10                         |
| 27    | 0D4255  | 2    | GASKET EXHAUST MANIFOLD                             |
| 28    | 070010  | 2    | SCREW HHC M8-1.25 X 35 SS G8.8                      |
| 29    | 0D2244M | 1    | ASSY MAGPICKUP (3/8-24 MALE)                        |
| 30    | 0F3844  | 8    | WASHER FLAT .43 X 1.00                              |
| 31    | 052647  | 6    | SCREW SHC M10-1.5 X 25 G12.9                        |
| 32    | 046526  | 6    | WASHER LOCK M10                                     |
| 33    | 039253  | 1    | SCREW HHC M8-1.25 X 20 G8.8                         |
| 34    | 070008  | 10   | WASHER FLAT M8 SS                                   |
| 35    | 070006  | 30   | WASHER LOCK M8 SSTL                                 |
| 36    | 0D2608  | 10   | SCREW HHC 5/16-18 X 1/2 SSTL                        |
| 37    | 0F5114  | 1    | DECAL REFER TO OWNERS MANUAL                        |
| 38    | 0F5454  | 1    | PLATE MAG PICK-UP ADAPTOR                           |
| 40    | 0F6104  | 1    | COVER STARTER 5.4 & 6.8 FORD CPL                    |
| 43    | 057823  | 2    | CLAMP HOSE #10 .56-1.06                             |
| 44    | 046964  | 1    | ELBOW 90D 1/4 NPT F-M BRASS                         |

\* NOTE: I/N 7 IS FOR HOLDING SENSORS TO I/N 6.

\*\* NOTE: I/N 11 IS PART OF ENGINE P/N 0D3454.

# GROUP D

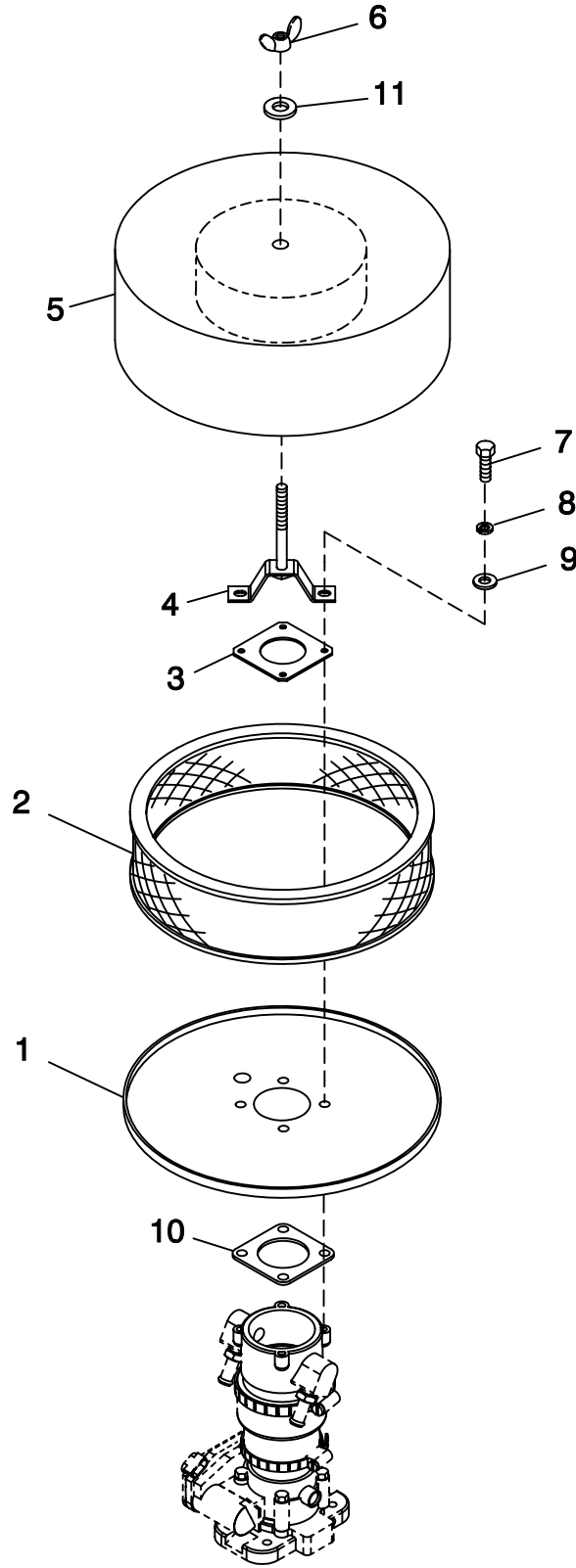

**EXPLODED VIEW: AIR CLEANER 5.4L/6.8L FORD**

**DRAWING #: 0F3569**

**GROUP D**

**APPLICABLE TO:**

| <b>ITEM</b> | <b>PART #</b> | <b>QTY.</b> | <b>DESCRIPTION</b>            |
|-------------|---------------|-------------|-------------------------------|
| 1           | 0D2513D       | 1           | AIR CLNR BTM PLT W/CPLR 8.1L  |
| 2           | 0F5419        | 1           | ELEMENT AIR FILTER            |
| 3           | 0F4268        | 1           | TOP PLATE VENTURI             |
| 4           | 0F4270A       | 1           | HOLD DOWN AIR CLEANER PLATED  |
| 5           | 0F6977        | 1           | PLATE AIR CLEAN TOP 5.4L/6.8L |
| 6           | 037561        | 1           | NUT WING 1/4-20 NYLK          |
| 7           | 047411        | 4           | SCREW HHC M6-1.0 X 16 G8.8    |
| 8           | 022097        | 4           | WASHER LOCK M6-1/4            |
| 9           | 049811        | 4           | WASHER FLAT M6                |
| 10          | 0F4269        | 1           | GASKET MIXER BODY             |
| 11          | 022473        | 1           | WASHER FLAT 1/4-M6 ZINC       |

GROUP D

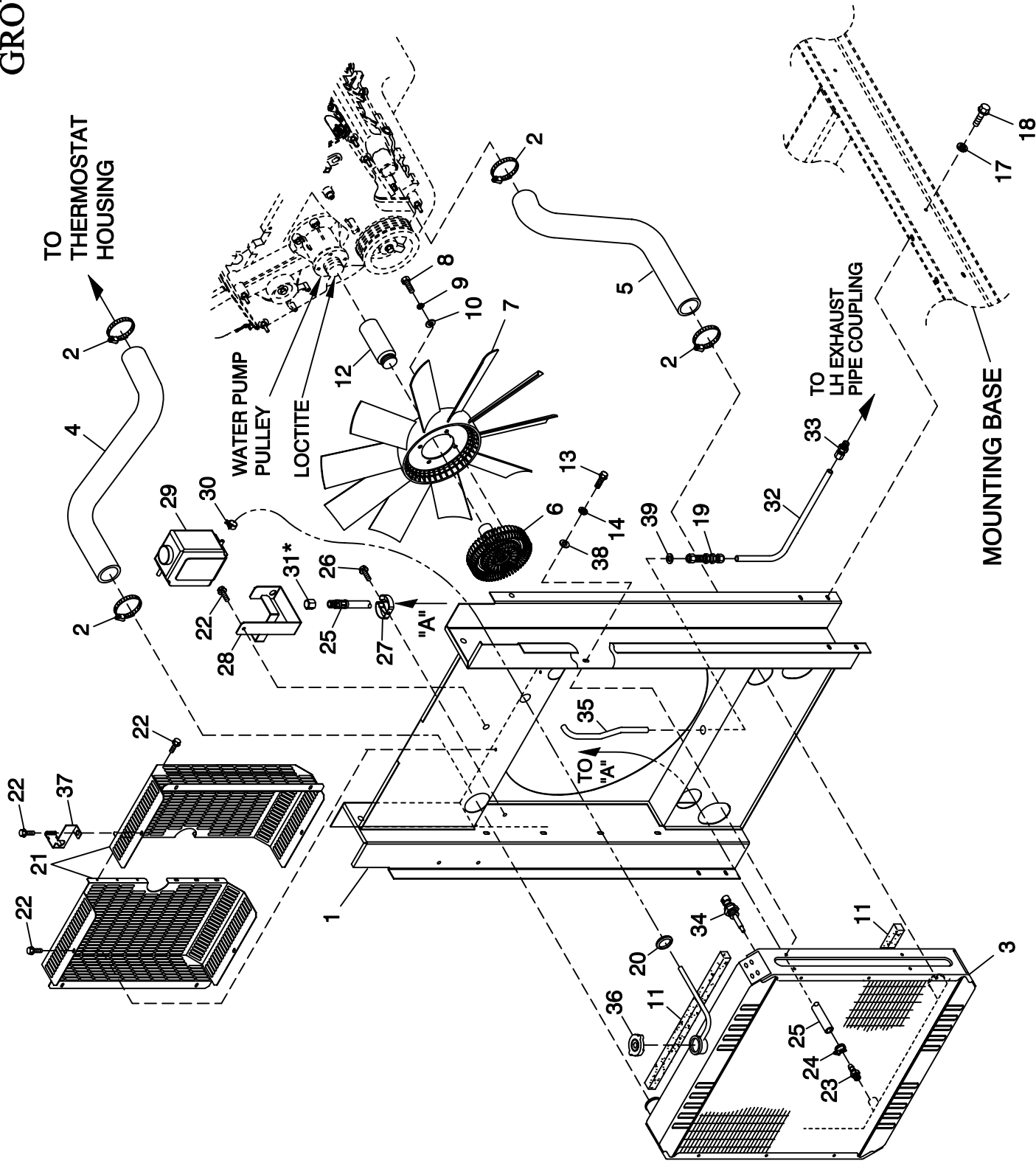

EXPLODED VIEW:  
C3 COOLING SYSTEM & FAN DRIVE  
DRAWING #: 0F3586

**EXPLODED VIEW: C3 COOLING SYSTEM & FAN DRIVE**  
**DRAWING #: 0F3586**

**GROUP D**

APPLICABLE TO:

| ITEM | PART #  | QTY. | DESCRIPTION                       |
|------|---------|------|-----------------------------------|
| 1    | 0F3144  | 1    | WELDMENT RAD SUPPORT C3 (22")     |
| 2    | 035685  | 4    | CLAMP HOSE #28 1.32-2.25          |
| 3    | 0F2857A | 1    | RADIATOR 581 X 585 X 70 CPL LH    |
| 4    | 0F4168  | 1    | HOSE UPPER RADIATOR C3            |
| 5    | 0F4169  | 1    | HOSE LOWER RADIATOR C3            |
| 6    | 0E7854  | 1    | CLUTCH COOLING FAN                |
| 7    | 0F2820  | 1    | FAN 22" DIA 10 BLADE              |
| 8    | 051756  | 4    | SCREW HHC M10-1.5 X 20 G8.8       |
| 9    | 046526  | 4    | WASHER LOCK M10                   |
| 10   | 022131  | 4    | WASHER FLAT 3/8-M10 ZINC          |
| 11   | 052250  | 2    | TAPE FOAM 1 X 1 (23" LG)          |
| 12   | 0F4412  | 1    | SPACER FAN 6.8L                   |
|      | 0F4412A | 1    | SPACER FAN 5.4L                   |
| 13   | 039253  | 8    | SCREW HHC M8-1.25 X 20 G8.8       |
| 14   | 022129  | 8    | WASHER LOCK M8-5/16               |
| 17   | 022097  | 8    | WASHER LOCK M6-1/4                |
| 18   | 0C8566  | 8    | SCREW HHFC M6-1.0 X 20 G8.8       |
| 19   | 0F4765  | 1    | FTG CMPN BLKHD 3/8" OD TUBE BRG   |
| 20   | 089685  | 1    | GROMMET .75 X .12 X .50           |
| 21   | 0F5589  | 2    | GUARD FAN C3 CPL                  |
| 22   | 0C2454  | 11   | SCREW THF M6-1 X 16 N WA Z/JS     |
| 23   | 055596  | 1    | BARBED STR 3/8 NPT X 3/8          |
| 24   | 0C7649  | 1    | CLAMP HOSE .38-.87                |
| 25   | 069860E | 1    | HOSE DRAIN ASSY 28"               |
| 26   | 045764  | 1    | SCREW HHTT M4-0.7 X 8 BP          |
| 27   | 065852  | 1    | SPRING CLIP HOLDER .37-.62        |
| 28   | 080712  | 1    | BRKT COOLANT RECOVERY TANK        |
| 29   | 076749  | 1    | TANK COOLANT RECOVERY             |
| 30   | 048031C | 1    | CLAMP HOSE BAND 1/4               |
| 31 * | 069811  | REF  | CAP HEX 1/4 NPT BRASS             |
| 32   | 0F4770  | 1    | TUBE FAN CLUTCH PREHTR LOWR C3    |
| 33   | 089514  | 1    | FTG CMPR 3/8TUBE X 3/8 NPT W/FERL |
| 34   | 0E2507  | 1    | PROBE COOLANT LEVEL 3/8 NPTF      |
| 35   | 0F4767  | 1    | TUBE FAN CLUTCH PREHTR UPPR C2    |
| 36   | 090283  | 1    | CAP RADIATOR 13 PSI               |
| 37   | 0F2776A | 1    | BRACKET SIGNAL CONDITIONER        |
| 38   | 022145  | 8    | WASHER FLAT 5/16-M8 ZINC          |
| 39   | 022132  | 1    | WASHER FLAT 9/16 ZINC             |

\* ITEM 31 IS INCLUDED WITH ITEM 25.

# GROUP D

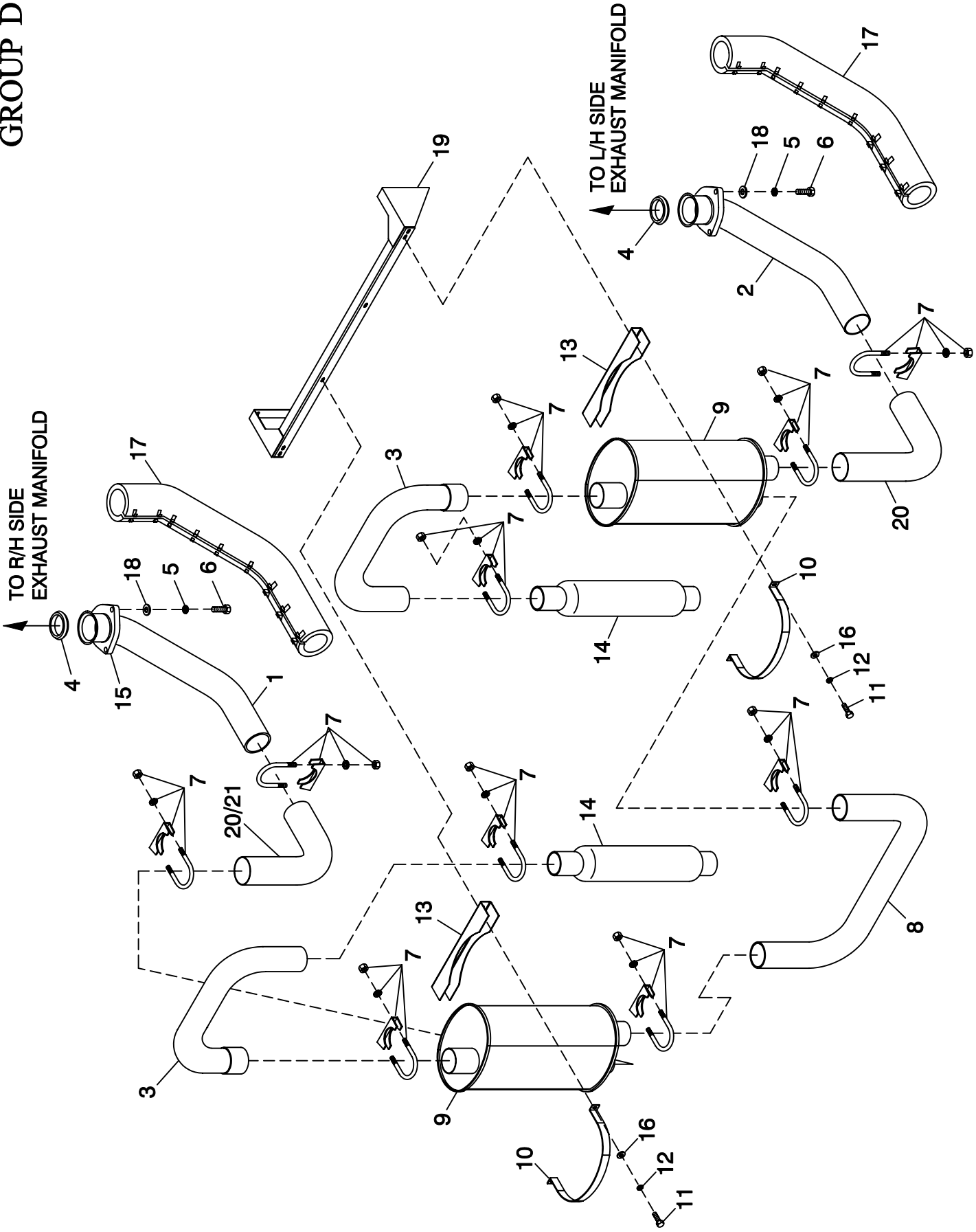

EXPLODED VIEW:  
MUFFLER 5.4L/6.8L CPL EXHAUST C3  
DRAWING #: 0F3601

**EXPLODED VIEW: MUFFLER 5.4L/6.8L CPL EXHAUST C3**  
**DRAWING #: 0F3601**

**GROUP D**

**APPLICABLE TO:**

| <b>ITEM</b> | <b>PART #</b> | <b>QTY.</b> | <b>DESCRIPTION</b>                       |
|-------------|---------------|-------------|--|
| 1           | 0F3224        | 1           | PIPE EXH MANIFOLD 6.8L C3 RH (6.8L 70KW) |
|             | 0F3224A       | 1           | PIPE EXH MANIFOLD 5.4L C3 RH (5.4L 55KW) |
| 2           | 0F3231        | 1           | PIPE EXH MANIFOLD 6.8L C3 LH (6.8L 70KW) |
|             | 0F3231A       | 1           | PIPE EXH MANIFOLD 5.4L C3 LH (5.4L 55KW) |
| 3           | 0F2808B       | 2           | PIPE EXHAUST MUFFLER OUT                 |
| 4           | 0A6765        | 2           | RING GASKET, 2.5DIA                      |
| 5           | 0F4710        | 6           | WASHER LOCK M10 SS                       |
| 6           | 0F7200        | 6           | SCREW HHC M10-1.5 X 50 SS FTH            |
| 7           | 080762        | 10          | BOLT U 3/8-16 X 2.62                     |
| 8           | 0F2809        | 1           | PIPE EXHAUST CROSSOVER                   |
| 9           | 0F2981A       | 2           | MFLR 7" X 9" X 25" (2) 2.5" IN/2.5" OUT  |
| 10          | 0F2962        | 2           | MUFFLER STRAP                            |
| 11          | 047411        | 4           | SCREW HHC M6-1.0 X 16 G8.8               |
| 12          | 022097        | 4           | WASHER LOCK M6-1/4                       |
| 13          | 0F2830        | 2           | MUFFLER BRACKET STIFFENER                |
| 14          | 0F4505        | 2           | GLASS PACK 23.5" LG 2.5" IN/OUT          |
| 15          | 0D3159        | 1           | FLANGE EXHAUST                           |
| 16          | 022473        | 4           | WASHER FLAT 1/4-M6 ZINC                  |
| 17          | 0F2773D       | 2           | EXHAUST BLANKET 800MM LG (6.8L 70KW)     |
|             | 0F2773E       | 2           | EXHAUST BLANKET 750MM LG (5.4L 55KW)     |
| 18          | 088775        | 6           | WASHER FLAT 3/8 SS                       |
| 19          | 0F5447        | 1           | BRKT MUFFLER                             |
| 20          | 0F6166 *      | 2           | PIPE LH MUFFLER SIDE                     |
|             | 0F6166 **     | 1           | PIPE LH MUFFLER SIDE                     |
| 21          | 0F6166A **    | 1           | PIPE RH MUFFLER SIDE                     |

**NOTES:**

\* 6.8L ONLY

\*\* 5.4L ONLY

# GROUP B

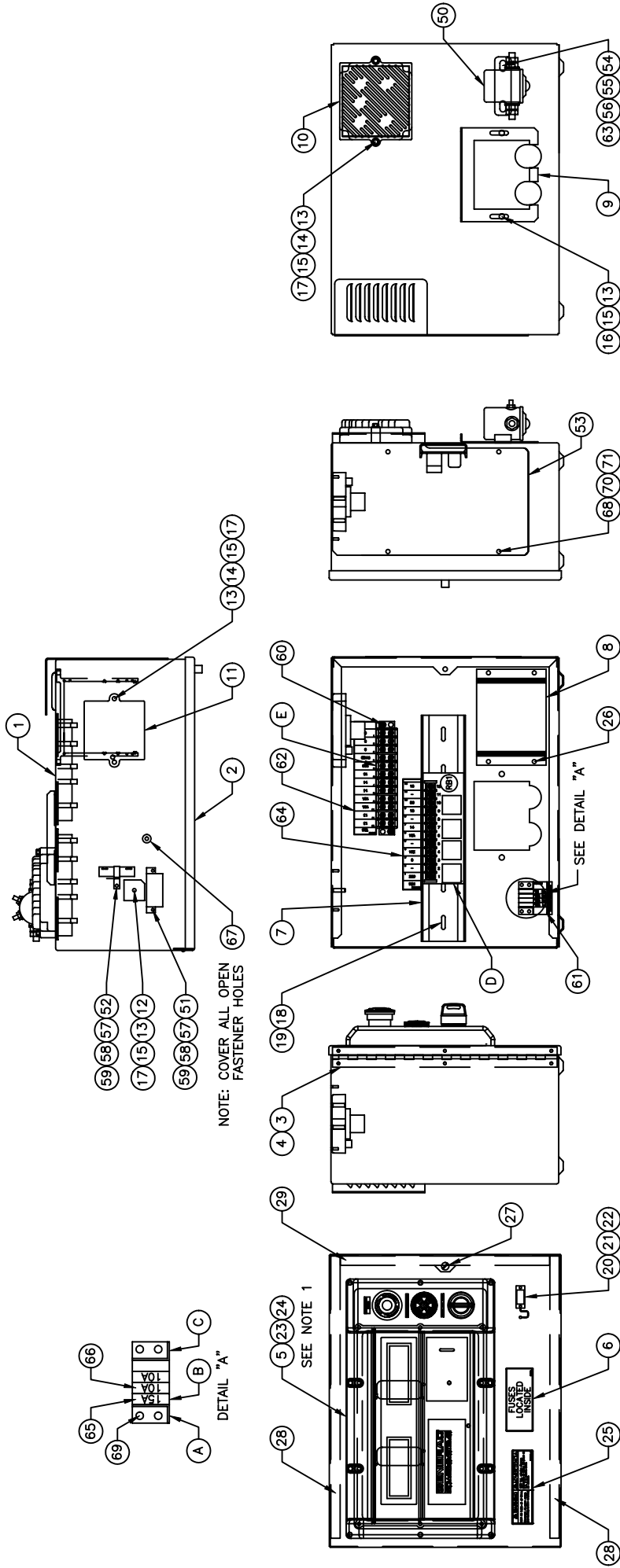

NOTE 1: ITEM 30 ATTACHES TO CONTACT ON REAR OF ITEM 5

EXPLODED VIEW:  
H PANEL 2A BATTERY CHARGER  
DRAWING #: 0G4139D

REVISION: -A-  
DATE: 12/13/06



**EXPLODED VIEW: H PANEL 2A BATTERY CHARGER**  
**DRAWING #: 0G4139D**

**GROUP B**

APPLICABLE TO:

| ITEM   | PART #      | QTY. | DESCRIPTION                             |
|--|-------------|------|---|
| COMPONENTS INCLUDED IN 0G4139E                     |             |      |   |
| 1  | 0F1823CST06 | 1    | ENCL H/G CONTROL PANEL                  |
| 2  | 0F1824AST06 | 1    | COVER CONTROL PANEL                     |
| 3  | 0F2606      | 1    | HINGE CONTINUOUS H PANEL                |
| 4  | 036261      | 6    | RIVET POP .125 X .275 SS                |
| 5  | 0F5763      | 1    | ASSY PROGRAMMED H-100                   |
| 6  | 0F1732      | 1    | DECAL FUSES LOCATED INSIDE              |
| 7  | 0E9764      | 1    | RAIL SNAPTRACK PCB HOLDER BULK (12"LG)  |
| 8  | 0F1725C     | 1    | ASSY PCB 2AMP 12V UL BATT CHGR          |
| 9  | 0F1958      | 1    | PLATE HARNESS CLAMP                     |
| 10   | 0F2256      | 1    | ASSY PCB PWR AVR W/AMP HEADER           |
| 11   | 0E3161      | 1    | ASSY PCB BOSCH GOV DRIVER               |
| 12   | 029673      | 1    | DIO BRIDGE 25A 600V                     |
| 13   | 049226      | 7    | WASHER LOCK M5                          |
| 14   | 079224      | 4    | SCREW PPHM M5-0.8 X 30 SS               |
| 15   | 051713      | 7    | WASHER FLAT M5                          |
| 16   | 0F5886      | 2    | SCREW HHPM M5-0.8 X 12                  |
| 17   | 051716      | 5    | NUT HEX M5-0.8 G8 YEL CHR               |
| 18   | 043180      | 3    | WASHER FLAT M4                          |
| 19   | 0C3990      | 3    | SCREW PHTT M4-0.7 X 10 ZYC              |
| 20   | 0F4333      | 1    | CONN DUST CAP W/CHAIN DB9               |
| 21   | 0F5883      | 1    | WASHER FLAT M3.5                        |
| 22   | 0F5884      | 1    | SCREW PHTT M3.5-0.6 X 10                |
| 23   | 055014      | 10   | SCREW PPHM M4-0.7 X 8 BLX OX            |
| 24   | 022264      | 10   | WASHER LOCK #8-M4                       |
| 25   | 0G3546      | 1    | DECAL WRN BATT CHR 12/24V BI            |
| 26   | 0C2265      | 4    | SCREW PHTT M4-0.7 X 12 ZYC              |
| 27   | 0G3648      | 1    | M5-0.8 CAPTIVE PANEL KNLD HD            |
| 28   | 0F6305      | 2    | SEAL COVER 3.18 X 12.7 X 382            |
| 29   | 0F6305A     | 1    | SEAL COVER 3.18 X 12.7 X 283            |
| 30   | 0G4329      | 1    | HARNESS H-PNL INTEGRATED SW (NOT SHOWN) |
| COMPONENTS INCLUDED IN WIRE HARNESS                |             |      |   |
| A  | 0F1263      | 1    | ADPTR RH SIDE WICKMANN 178.6191         |
| B  | 0F1262      | 4    | HOLDER FUSE WICKMANN 178.6150           |
| C  | 0F1264      | 1    | ADPTR LH SIDE WICKMANN 178.6192         |
| D  | 0E9049B     | 1    | ASSY PCB G-PANEL RELAY 12VDC            |
| E  | 055911      | 1    | BLOCK TERM 20A 12 X 6 X 1100V           |
| COMPONENTS NOT INCLUDED IN 0G4139E OR WIRE HARNESS |             |      |   |
| 50   | 056739      | 1    | RELAY CONTACTOR 12VDC                   |
| 51   | -           | 1    | DPE BREAKER SEE DRAWING 0F9280          |
| 52   | -           | 1    | BOOST RESISTOR SEE DRAWING 0F9280       |
| 53   | 0F2627A     | 1    | COVER CONTROL PANEL SIDE                |
| 54   | 022287      | 2    | SCREW HHC 1/4-20 X 3/4 G5               |
| 55   | 022473      | 4    | WASHER FLAT M6-1/4                      |
| 56   | 022097      | 2    | WASHER LOCK M6-1/4                      |
| 57   | 043182      | 3    | WASHER LOCK M3                          |
| 58   | 051714      | 3    | NUT HEX M3-0.5 G8 YEL CHR               |
| 59   | 052777      | 3    | WASHER FLAT M3                          |
| 60   | 0C2323      | 2    | SCREW PHTT #6-32 X 5/8 ZYC              |
| 61   | 0F5459      | 1    | DECAL CPL CONTROL PANEL FUSES           |
| 62   | 0F5461      | 1    | DECAL CPL 5.4/6.8L TB3                  |
| 63   | 022127      | 2    | NUT HEX 1/4-20 STEEL                    |
| 64   | 0F5460      | 1    | DECAL CPL 5.4/6.8L RELAY BOARD          |
| 65   | 0E7403C     | 1    | FUSE ATO TYPE 15 AMP (BLUE)             |
| 66   | 0E7403B     | 2    | FUSE ATO TYPE 10 AMP (RED)              |
| 67   | 0F6145      | A/R  | SEAL WEATHER .45"DIA                    |
| 68   | 091526      | 4    | SCREW PPHM M5-0.8 X 12 ZNC              |
| 69   | 0C2699      | 2    | SCREW PHTT #6-32 X 3/8 ZYC              |
| 70   | 051713      | 4    | WASHER FLAT M5                          |
| 71   | 049226      | 4    | WASHER LOCK M5                          |

# GROUP E

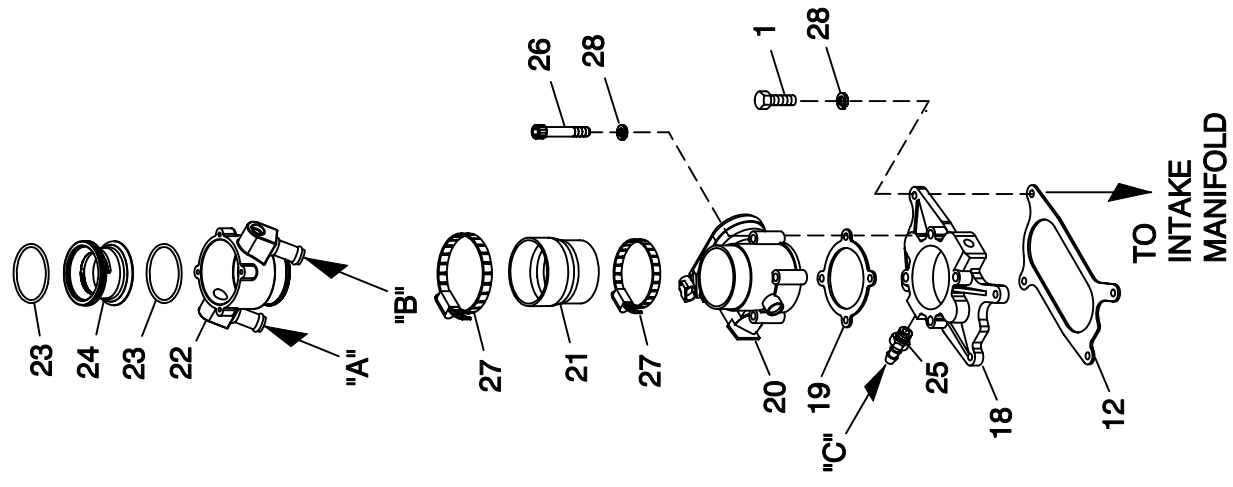

**EXPLODED VIEW:**  
**FUEL NAT. GAS & LP VAPOR 6.8L FORD - 4 POLE**  
**DRAWING #: 0F3595**

**NOTE:**  
 HOSES (I/N'S 14 & 31)  
 ROUTED TO LAY ON  
 I/N 32.

**INTAKE  
 MANIFOLD**

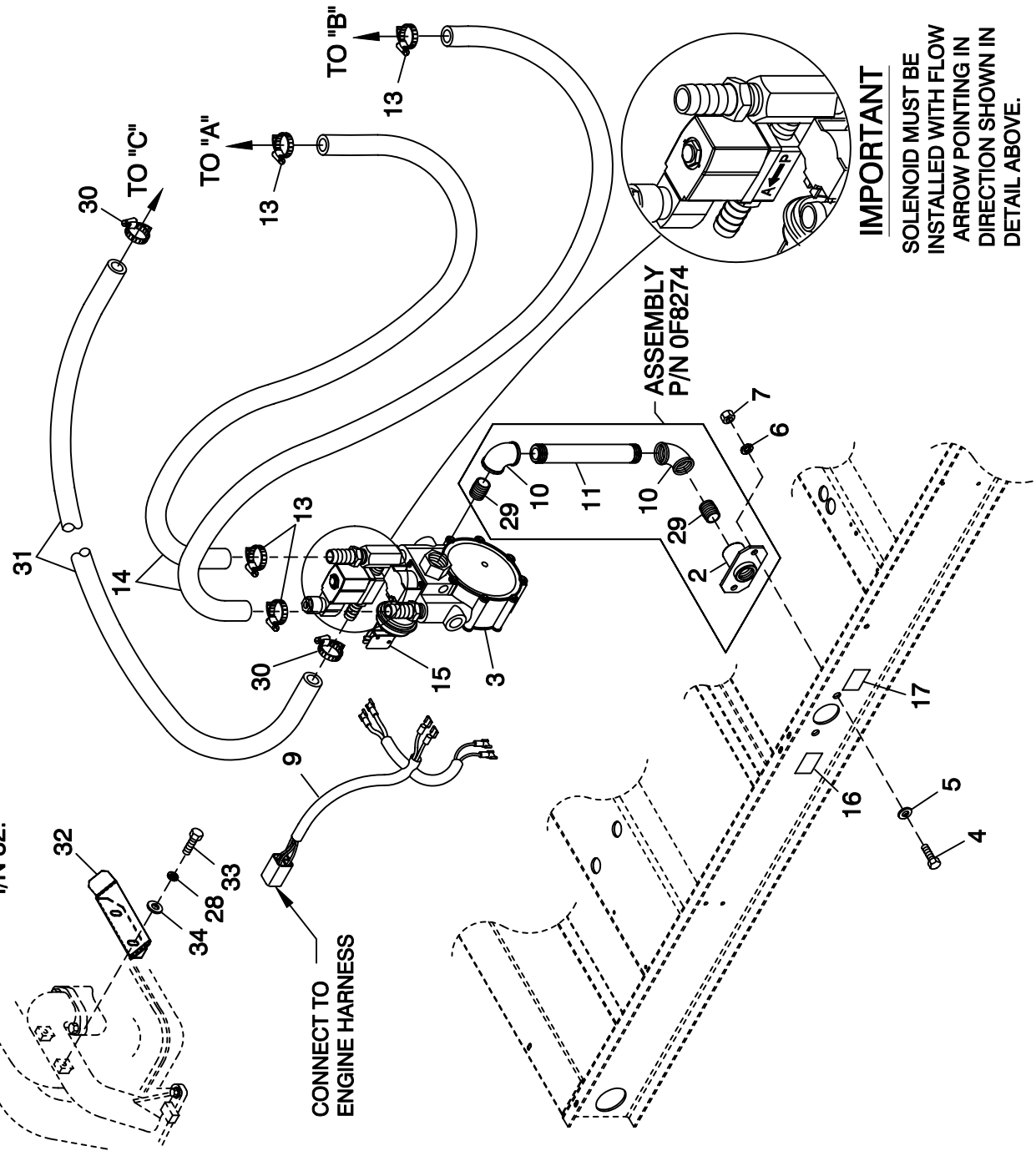

**IMPORTANT**

SOLENOID MUST BE  
 INSTALLED WITH FLOW  
 ARROW POINTING IN  
 DIRECTION SHOWN IN  
 DETAIL ABOVE.

**CONNECT TO  
 ENGINE HARNESS**

## EXPLODED VIEW: FUEL NAT. GAS &amp; LP VAPOR 6.8L FORD - 4 POLE

DRAWING #: 0F3595

GROUP E

APPLICABLE TO:

| ITEM | PART #      | QTY.    | DESCRIPTION                                   |
|------|-------------|---------|---|
| 1    | 049721      | 4       | SCREW HHC M6-1.0 X 35 G8.8 BLK                |
| 2    | 075580      | 1       | FLANGE FUEL INLET                             |
| 3    | 0F6260H     | 1       | REGULATOR ASSM 6.8L70KW NATGAS                |
|      | 0F6260D     | 1       | REGULATOR ASSM 6.8L 70KW LPV                  |
| 4    | 039253      | 2       | SCREW HHC M8-1.25 X 20 G8.8                   |
| 5    | 022145      | 2       | WASHER FLAT 5/16-M8 ZINC                      |
| 6    | 022129      | 2       | WASHER LOCK M8-5/16                           |
| 7    | 045771      | 2       | NUT HEX M8-1.25 G8 CLEAR ZINC                 |
| 9    | 0F6155      | 1       | HARNESS,FUEL JUMPER SINGLE REG                |
| 10   | 026812      | 2       | ELBOW 90D 3/4NPT                              |
| 11   | 0F8379      | 1       | NIPPLE PIPE 3/4NPT X 7                        |
| 12   | 0D2698      | 1       | GASKET ADAPTER THROT BODY                     |
| 13   | 057823      | 4       | CLAMP HOSE #10 .56-1.06                       |
| 14   | 059057      | 2       | HOSE 3/4 ID SAE-30R2 (38.5" LG)               |
| 15   | 0F3869      | 1(REF.) | SWITCH, PRESSURE GAS 5" RISE                  |
| 16   | 0D1509      | 1       | DECAL INLET PRESSURE                          |
| 17   | 050279      | 1       | DECAL FUEL INLET NG (NATURAL GAS APPLICATION) |
|      | 050280      | 1       | DECAL FUEL INLET LPG (LP VAPOR APPLICATION)   |
| 18   | 0D2696B     | 1       | ADAPTOR, THROTTLE BODY (BOSCH)                |
| 19   | 0E4390      | 1       | GASKET, GOVERNOR ACTUATOR                     |
| 20   | 0E4392      | 1       | ACTUATOR BOSCH 60, GOVERNOR                   |
| 21   | 0F0960      | 1       | REDUCER 3.0" TO 2.75" TURBO                   |
| 22   | 0F3885      | 1       | MIXER, 40/60MM ACTUATOR ASSY                  |
| 23   | 0G3167      | 2       | O-RING 2-3/4 X 3/32 X 2-15/16                 |
| 24   | 0F3691B     | 1       | VENTURI, THROTTLE 36MM                        |
| 25   | 035461      | 1       | BARBED STR 1/4NPT X 3/8                       |
| 26   | 046580      | 4       | SCREW SHC M6-1.0 X 45 G12.9                   |
| 27   | 039294      | 2       | CLAMP HOSE #44 2.31-3.25                      |
| 28   | 022097      | 10      | WASHER LOCK M6-1/4                            |
| 29   | 026915      | 2       | NIPPLE CLOSE 3/4 X 1.375                      |
| 30   | 040173      | 2       | CLAMP HOSE #5.5 .62-.62                       |
| 31   | 047290      | 1       | HOSE 3/8 ID SINGLE BRAID (36" LG)             |
| 32   | 0G46350ST03 | 1       | BRACKET, HOSE RISER                           |
| 33   | 042568      | 2       | SCREW HHC M6-1.0 X 20 G8.8                    |
| 34   | 049811      | 2       | WASHER FLAT M6                                |

# GROUP F

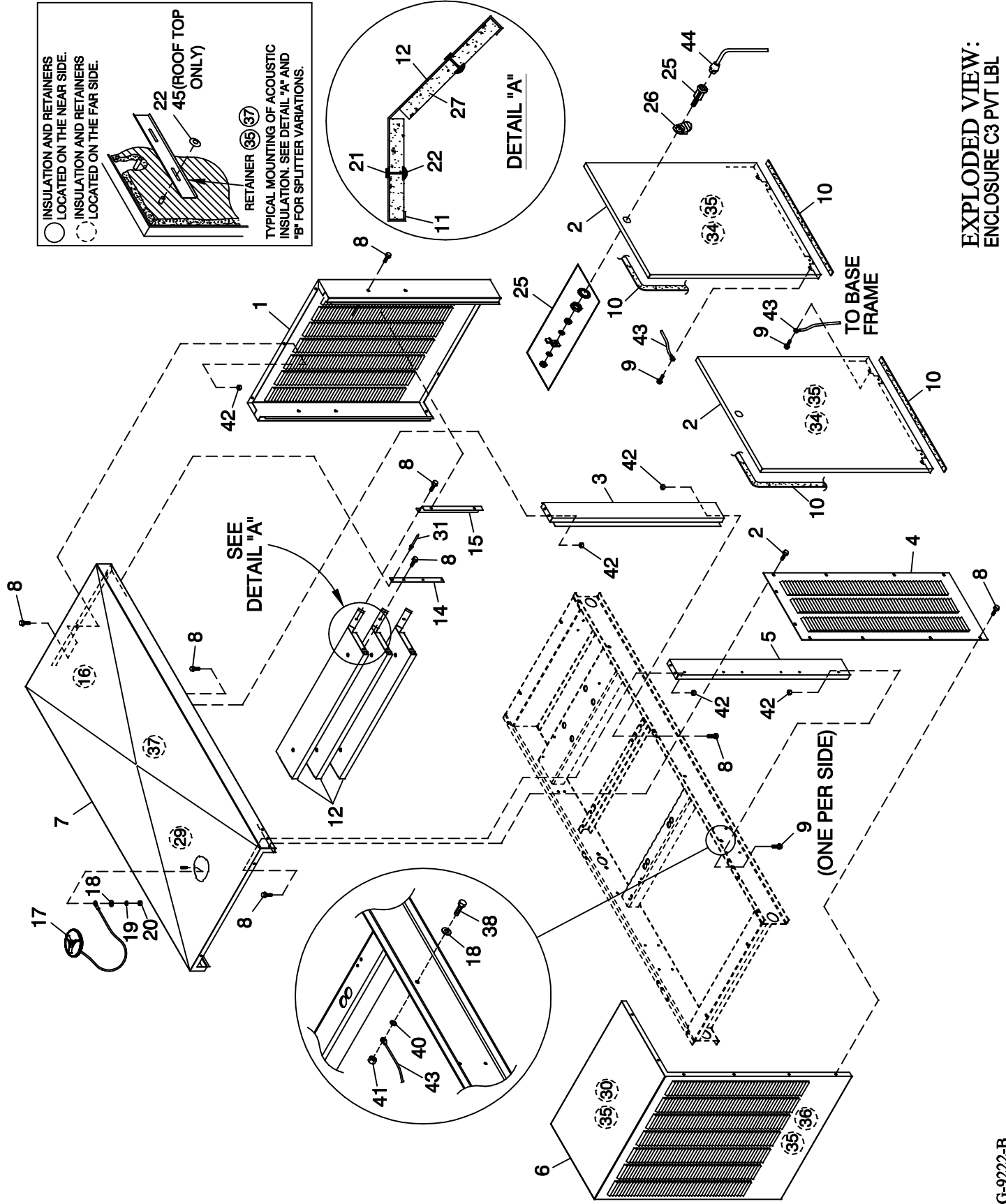

EXPLODED VIEW:  
ENCLOSURE C3 PVT LBL  
DRAWING #: 0G2898

APPLICABLE TO:

| ITEM   | PART #     | QTY. | DESCRIPTION                         |
|--------|------------|------|-------------------------------------|
| (2) 1  | 0F5866     | 1    | REAR WRAP C3                        |
| (2) 2  | 0F5861     | 4    | DOOR C3                             |
| (2) 3  | 0F5865     | 2    | CENTER SUPPORT C3                   |
| (2) 4  | 0F5864     | 2    | DISCHARGE DUCT LH & RH SIDE C3      |
| (2) 5  | 0F5862     | 2    | FRONT CORNERS C3                    |
| (2) 6  | 0F5863     | 1    | DISCHARGE CENTER DUCT C3            |
| (2) 7  | 0F5860     | 1    | ROOF C3 ALUM                        |
| 8      | 0C2454     | 40   | SCREW THF M6-1 X 16 N WA Z/JS       |
| 9      | 0E3257     | 6    | SCREW TH-FRM M6 W/CAP SHKPRF W      |
| 10     | 0E5968     | 1    | GASKET EXTRUDED TRIM (547" LG)      |
| 11     | 0F3949L    | 3    | INSULATION SPLITTER SML             |
| 12     | 0F2766     | 3    | SPLITTER                            |
| 14     | 0F3185     | 2    | STRINGER SPLITTER C3                |
| 15     | 0F3416     | 2    | SUPPORT SPLITTER C5 130KW           |
| 16     | 0F3949E    | 1    | INSULATION ROOF TOP REAR            |
| 17     | 0F4487A    | 1    | ASSEMBLY COVER ACCESS               |
| 18     | 022473     | 5    | WASHER FLAT 1/4-M6 ZINC             |
| 19     | 022097     | 1    | WASHER LOCK M6-1/4                  |
| 20     | 022127     | 1    | NUT HEX 1/4-20 STEEL                |
| 21     | 0F3072     | 12   | INSULATION RETAINMENT HANGER        |
| 22     | 078115     | 30   | WASHER SELF LOCKING DOME #4-40      |
| 25     | 0F5048D    | 4    | WISE-ACTION LATCH SLOTTED CIR       |
| 26     | 0F5049     | 4    | TAB PULL                            |
| 27     | 0F3949B    | 3    | INSULATION SPLITTER                 |
| 29     | 0F4073A    | 1    | INSULATION ROOF TOP                 |
| 30     | 0F4073F    | 1    | INSULATION DUCT TOP                 |
| 31     | 087233     | 2    | RIVET POP .1875 X .450 SS           |
| 32     | 0F3180     | 1    | SPLITTER EXTENDED LENGTH            |
| 33     | 0F3635C    | 1    | INSULATION SPLITTER EXTENDED LENGTH |
| 34     | 0F4073     | 4    | INSULATION DOOR                     |
| 35     | 0F3890B    | 11   | RETAINER INSULATION (820)           |
| 36     | 0F4073B    | 1    | INSULATION DUCT FRONT               |
| 37     | 0F3890A    | 4    | RETAINER INSULATION (740)           |
| 38     | 042568     | 4    | SCREW HHC M6-1.0 X 20 G8.8          |
| 40     | 022447     | 4    | WASHER SHAKEPROOF INT 1/4           |
| 41     | 049813     | 4    | NUT HEX M6 X 1.0 G8 YEL CHR         |
| (1) 42 | 077992     | 29   | NUT HEX LOCK M6-1.0 SS NY INS       |
| 43     | 0912970094 | 4    | ASSY WIRE 14 AWG 34.8" GRN/YEL      |
| 44     | 0F8869D    | 1    | KEY WISE-ACTION LATCH SLOT CIR      |
| 45     | 078115A    | 10   | WASHER SELF LOCKING DOME #8-32      |

(1) ALUMINUM ENCLOSURE NOTE: ALL ENCLOSURE PANELS THAT FASTEN TO THE BASE FRAME MUST BE SECURED USING ITEM 8 & 9 THREAD FORMING FASTENER AND ITEM 42 LOCK NUT. LOCK NUT IS TO BE INSTALLED AFTER THREAD FORMING FASTENER HAS PENETRATED THROUGH EXTRUSIONS IN ENCLOSURE PANELS. ALL ROOF PANELS ARE TO BE SECURED IN THE SAME MANNER.

(2) I/N'S 1 THRU 7, REFER TO CHART BELOW FOR ENCLOSURE COLOR & MATERIAL TYPE.

| SUFFIX 1 (MATL.)  | SUFFIX 2 (COLOR) |
|---|------------------|
| AL (ALUMINUM)   | 01 (TAN)         |
|   | 03 (BLACK)       |
|   | 05 (WHITE)       |
|   | 07 (G-FORCE)     |
|   | 08 (TELECOM)     |
|   | 09 (CRAFTSMAN)   |
| ST (STEEL)  | OR (CUSTOM)      |
| GENERIC EXAMPLE: SUFFIX 1      SUFFIX 2<br>OF19870AL 01 |                  |

**GD CONNECTOR**

| PIN | WIRE | TO    | FUNCTION          |
|-----|------|-------|-------------------|
| 1   | 0    | GND   | NOTE 1            |
| 4   | 14   | RB1-7 | NOTE 3            |
| 8   | 771  | GA1-1 | THROTTLE DRIVE LO |
| 9   | 770  | GA1-4 | THROTTLE DRIVE HI |
| 10  | 0    | GND   | NOTE 1            |
| 12  | 769  | J1-33 | THROTTLE PWM      |

**AVR CONNECTOR**

| PIN | WIRE | TO    | FUNCTION              |
|-----|------|-------|-----------------------|
| 1   | 1    | FIELD | - FIELD               |
| 2   | 194  | J2-31 | +12VDC                |
| 3   | 6    | PME   | PME OUTPUT            |
| 4   | 4    | R1    | + FIELD               |
| 5   | 4    | FIELD | + FIELD               |
| 6   | 403  | J2-8  | GATE TRIGGER B        |
| 7   | 404  | J2-20 | GATE TRIGGER A        |
| 10  | 406  | J2-30 | ZERO CROSSING I/P     |
| 11  | 405  | J2-19 | GROUND (ISO)          |
| 13  | 162  | CB    | PME OUTPUT (AFTER CB) |

**ICM - IGNITION MODULE CONNECTOR**

| PIN | WIRE | TO         | FUNCTION                |
|-----|------|------------|-------------------------|
| 1   | 459  | CYL9       | IGNITION COIL DRIVE 9   |
| 2   | 460  | CYL10      | IGNITION COIL DRIVE 10  |
| 3   | 457  | CYL7       | IGNITION COIL DRIVE 7   |
| 4   | 451  | CYL1       | IGNITION COIL DRIVE 1   |
| 5   | 456  | CYL6       | IGNITION COIL DRIVE 6   |
| 6   | 452  | CYL2       | IGNITION COIL DRIVE 2   |
| 7   | 453  | CYL3       | IGNITION COIL DRIVE 3   |
| 8   | 454  | CYL4       | IGNITION COIL DRIVE 4   |
| 9   | 455  | CYL5       | IGNITION COIL DRIVE 5   |
| 10  | SHLD | CUT        | CAMSHAFT SENSOR DRAIN   |
| 11  | 56   | RB1-10     | STARTER RELAY OUT       |
| 12  | 14   | RB1-7      | NOTE 3                  |
| 13  | 0    | GND        | NOTE 1                  |
| 14  | 79A  | CSS-2      | CRANKSHAFT SENSOR +     |
| 15  | 458  | CYL8       | IGNITION COIL DRIVE 8   |
| 16  | 15C  | F3         | NOTE 7                  |
| 17  | 0    | GND        | NOTE 1                  |
| 18  | 15D  | CYL1-CYL10 | IGNITION COIL PWR       |
| 19  | 806  | J1-27      | IGNITION ALARM          |
| 20  | SHLD | CUT        | CRANKSHAFT SENSOR DRAIN |
| 21  | 0A   | CSS-1      | CRANKSHAFT SENSOR -     |
| 22  | 0    | CAM-1      | CAMSHAFT SENSOR -       |
| 23  | 450  | CAM-2      | CAMSHAFT SENSOR +       |

**ENGINE CONTROL MODULE CONNECTIONS**

**J1**

| PIN | WIRE | TO         | FUNCTION                   |
|-----|------|------------|----------------------------|
| 3   | 810  | MOD-2      | EXTERNAL MODEM GROUND      |
| 4   | 805  | O2         | OXYGEN SENSOR RTN (OPTION) |
| 5   | 804  | O2         | OXYGEN SENSOR + (OPTION)   |
| 10  | R15B | RB1A-3/ES1 | OVERSPEED/WATCHDOG         |
| 11  | 256  | RB1A-5     | FUEL RELAY                 |
| 12  | 0    | GND        | NOTE 1                     |
| 14  | 811  | MOD-3      | DCD                        |
| 15  | 68V  | WTS-1      | COOLANT TEMP +             |
| 16  | 803  | BCH        | BAT CHARGER CURRENT        |
| 17  | 766R | GA-2       | THROTTLE POS RTN           |
| 18  | 766V | GA-1       | THROTTLE POS +             |
| 19  | 69R  | OPS-3      | OIL PRESS RTN              |
| 20  | 69V  | OPS-1      | OIL PRESS +                |
| 21  | 808  | AFS        | AIR/FUEL SOLENOID (OPTION) |
| 23  | 56A  | RB1A-6     | STARTER RELAY              |
| 24  | 0    | MPU1-2     | MPU1 SIGNAL (-)            |
| 25  | 79   | MPU1-3     | MPU1 SIGNAL (+)            |
| 26  | 812  | MOD-4      | ENABLE                     |
| 27  | 806  | ICM-19     | IGNITION ALARM             |
| 29  | 573R | WLS-2      | COOLANT LVL RTN            |
| 30  | 573V | WLS-1      | COOLANT LVL +              |
| 31  | 68R  | WTS-2      | COOLANT TEMP RTN           |
| 32  | 809  | MOD-1      | +12                        |
| 33  | 769  | GD-12      | THROTTLE PWM               |
| 34  | 445  | RB1A-2     | ALARM RELAY                |
| 35  | 15B  | F2         | NOTE 6                     |

**J2**

| PIN  | WIRE | TO       | FUNCTION              |
|------|------|----------|-----------------------|
| 1    | 391  | CUST CON | RS485- (XFER SW)      |
| 2    | 388  | COM-3    | RS232 TX (GENLINK)    |
| 3    | DI3  | CUST CON | LINE POWER SIGNAL     |
| 4    | 183  | CUST CON | REMOTE START          |
| 5    | 174  | SW1      | "AUTO" START          |
| 6    | 224  | IFT      | V SENSE GEN A PH      |
| 7    | 227  | IFT      | V SENSE RTN           |
| 8    | 403  | AVR-6    | AVR GATE TRIGGER B    |
| * 9  | 399C | CT3      | GEN C PH CURRENT -    |
| * 10 | 398C | CT3      | GEN C PH CURRENT +    |
| 11   | 399A | CT1      | GEN A PH CURRENT -    |
| 12   | 398A | CT1      | GEN A PH CURRENT +    |
| 13   | 390  | CUST CON | RS485+ (XFER SW)      |
| 14   | 387  | COM-2    | RS232 RX (GENLINK)    |
| 15   | 601  | LFP      | LOW FUEL PRESSURE     |
| 16   | R15  | ES1      | EMERGENCY STOP        |
| * 17 | 226  | IFT      | V SENSE GEN C PH      |
| 19   | 405  | AVR-11   | AVR GROUND            |
| 20   | 404  | AVR-7    | AVR GATE TRIGGER A    |
| 24   | SHLD | CUST CON | RS485 DRAIN (XFER SW) |
| 25   | 389  | COM-5    | RS232 COM (GENLINK)   |
| 26   | DI4  | CUST CON | GEN POWER SIGNAL      |
| 27   | 505  | BCH      | BAT CHARGER FAIL      |
| 28   | 175  | SW1      | "MANUAL" START        |
| 29   | 225  | IFT      | V SENSE GEN B PH      |
| 30   | 406  | AVR-10   | AVR ZERO CROSSING I/P |
| 31   | 194  | AVR-2    | AVR +12VDC            |
| 34   | 399B | CT2      | GEN B PH CURRENT-     |
| 35   | 398B | CT2      | GEN B PH CURRENT+     |

\* - CONNECTIONS NOT USED IN 1Ø UNITS.

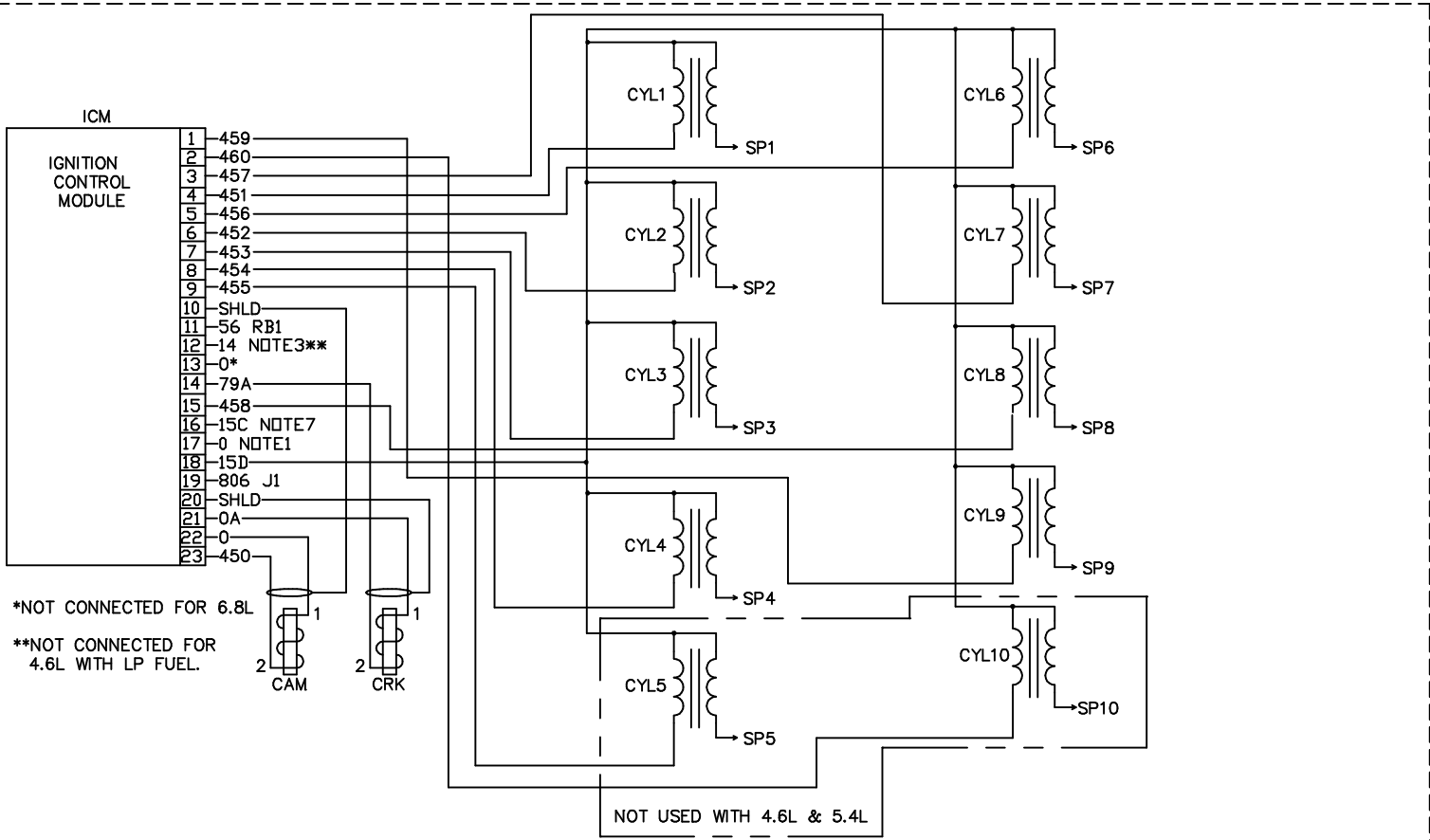

\*NOT CONNECTED FOR 6.8L

\*\*NOT CONNECTED FOR 4.6L WITH LP FUEL.

NOT USED WITH 4.6L & 5.4L

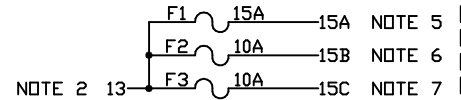
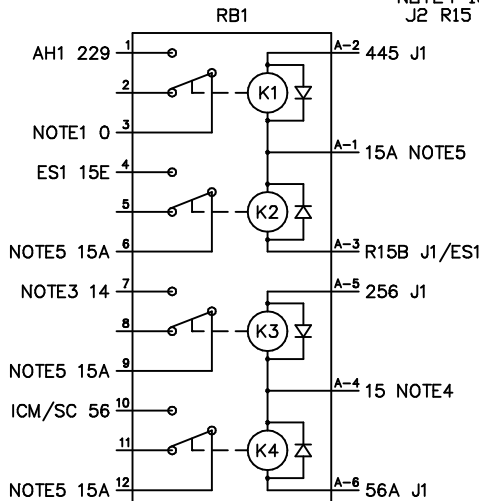
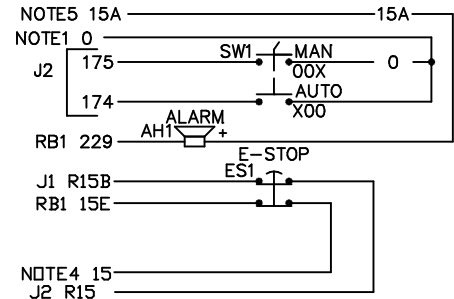
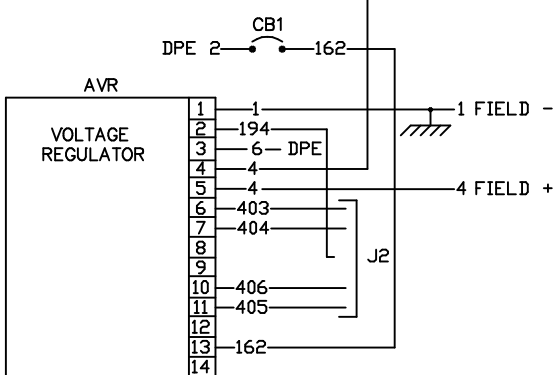
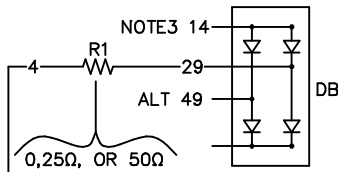
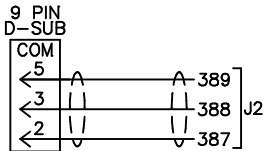

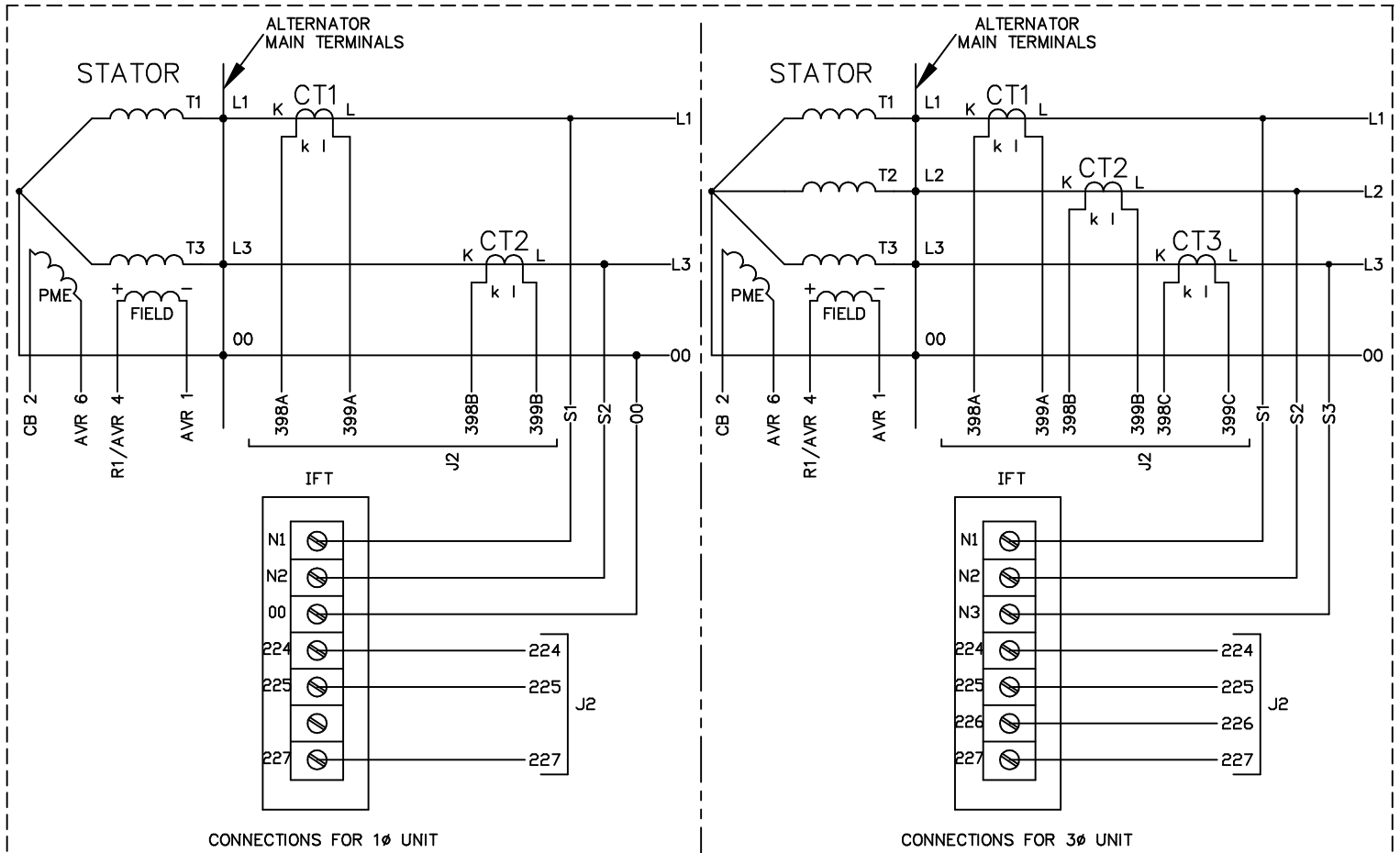

## ALTERNATOR CONNECTION BOX

### GENERATOR SET

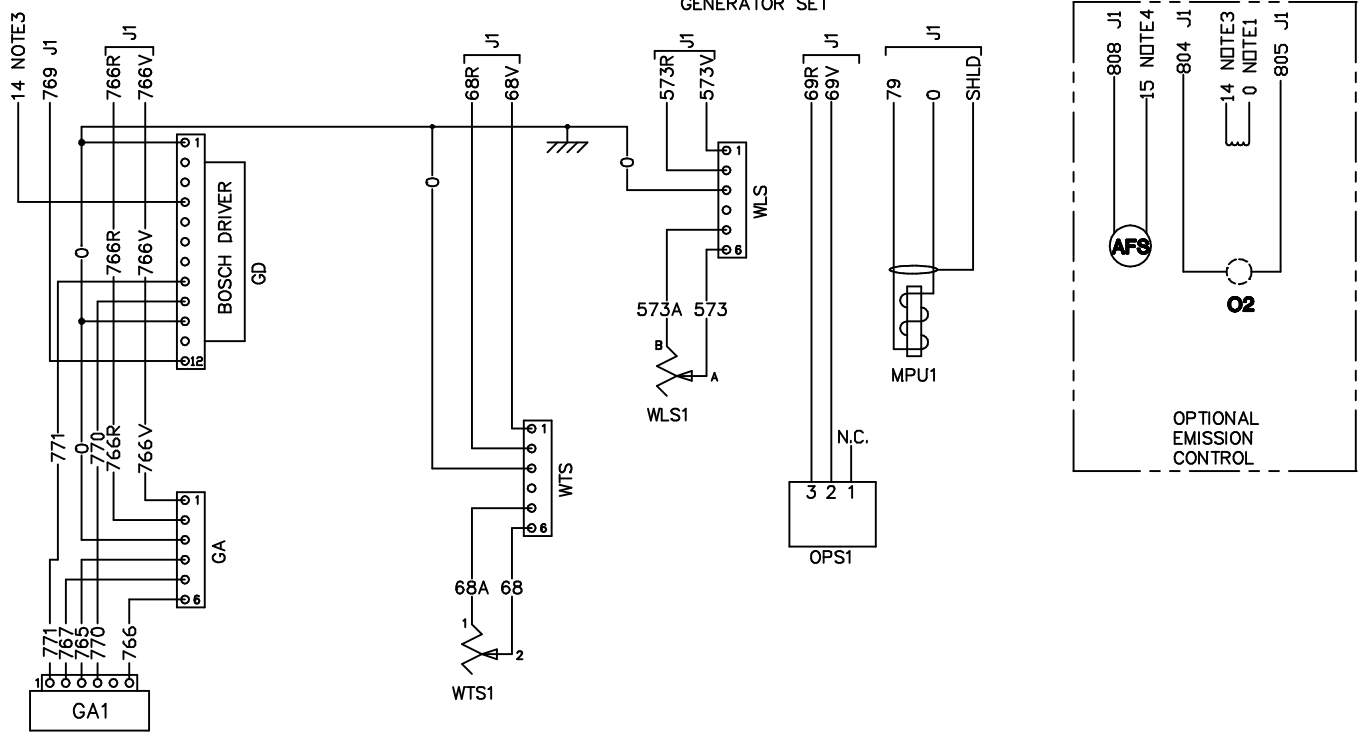



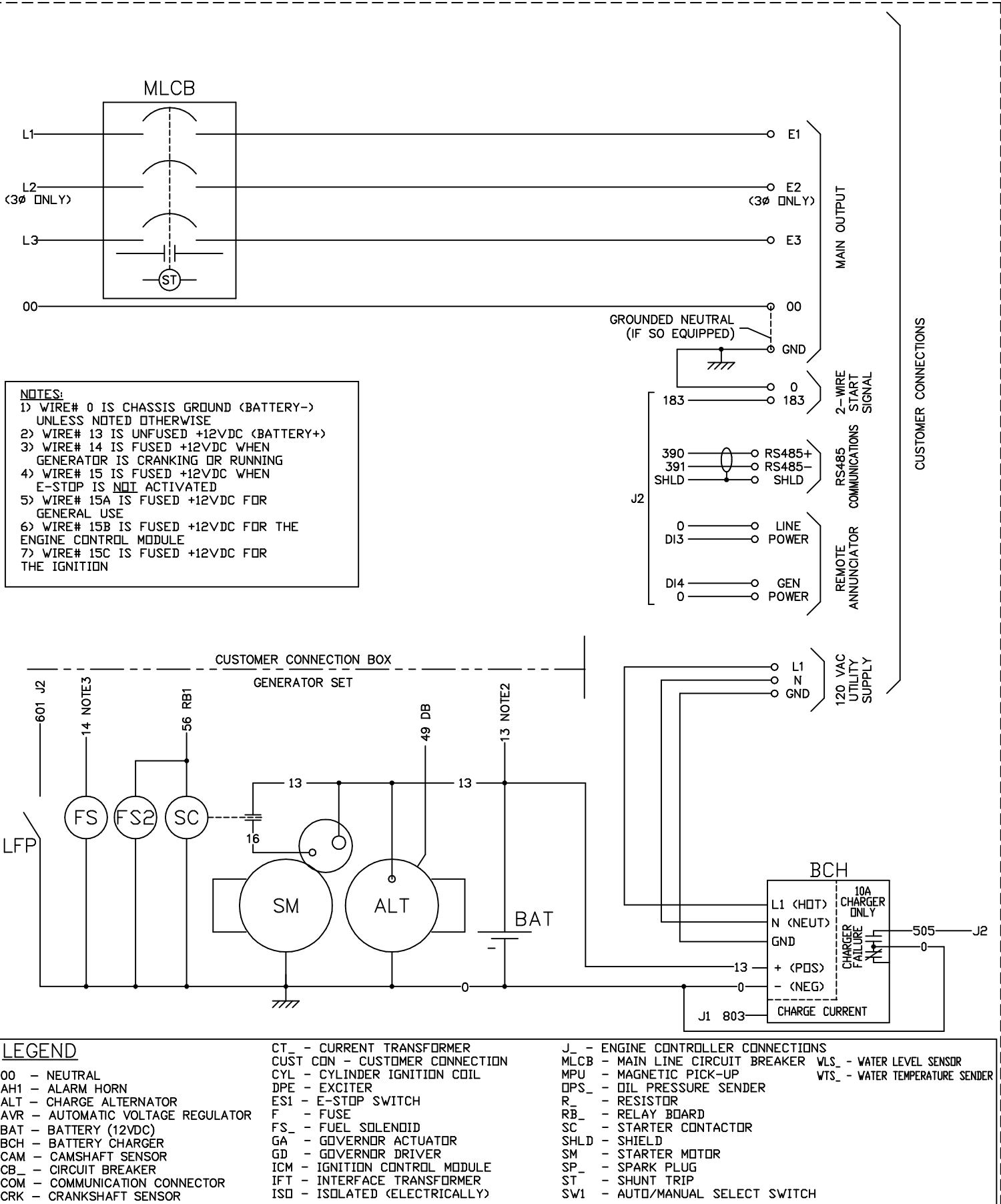

## COMPONENTS LOCATED ON ENGINE

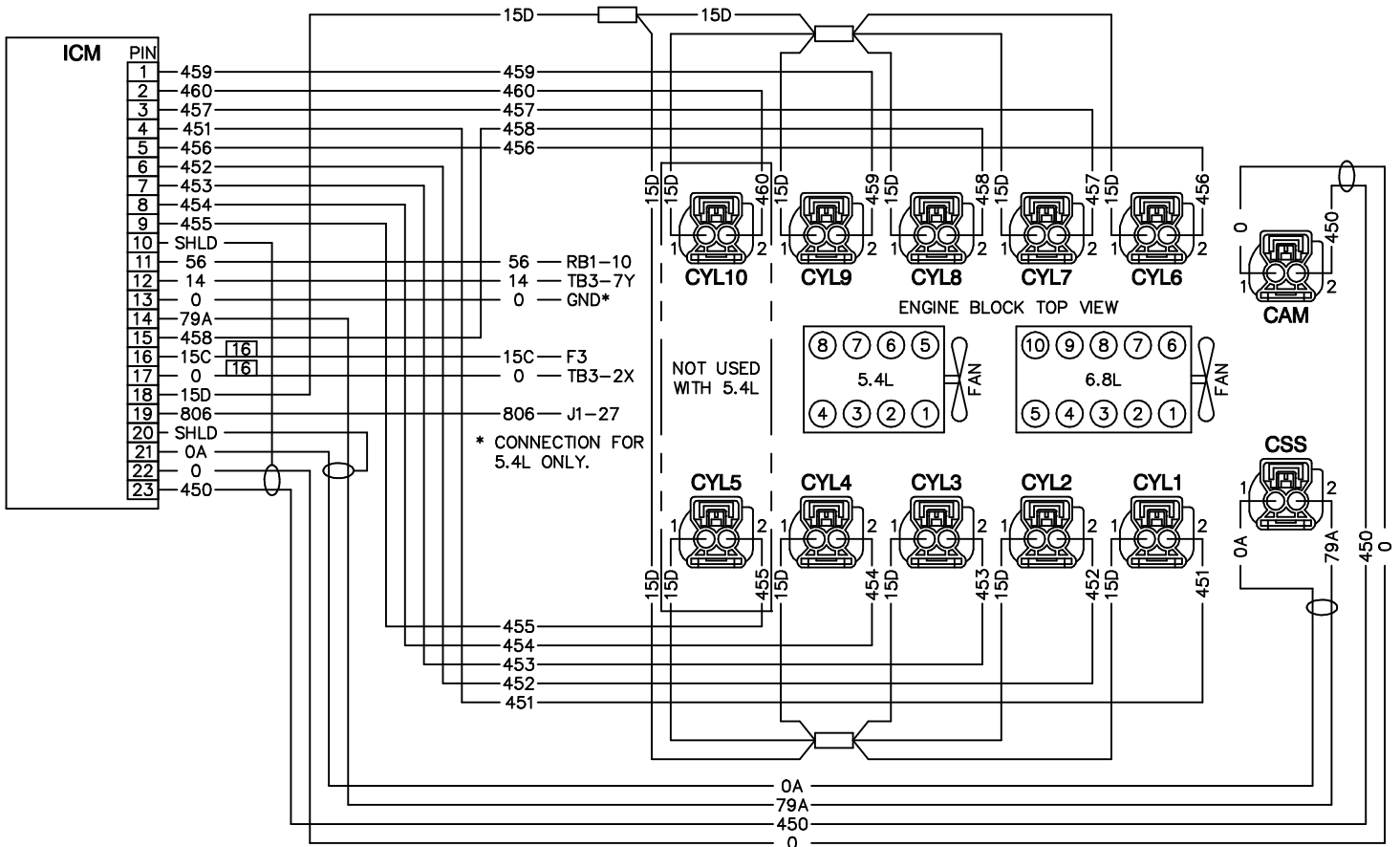

NOTE: ALL WIRES 18 AWG  
300V UL LISTED UNLESS  
SHOWN OTHERWISE

AWG SIZE

S1, S2 & S3 ARE 600V UL LISTED

OPTION NOT AVAILABLE ON CPL UNITS

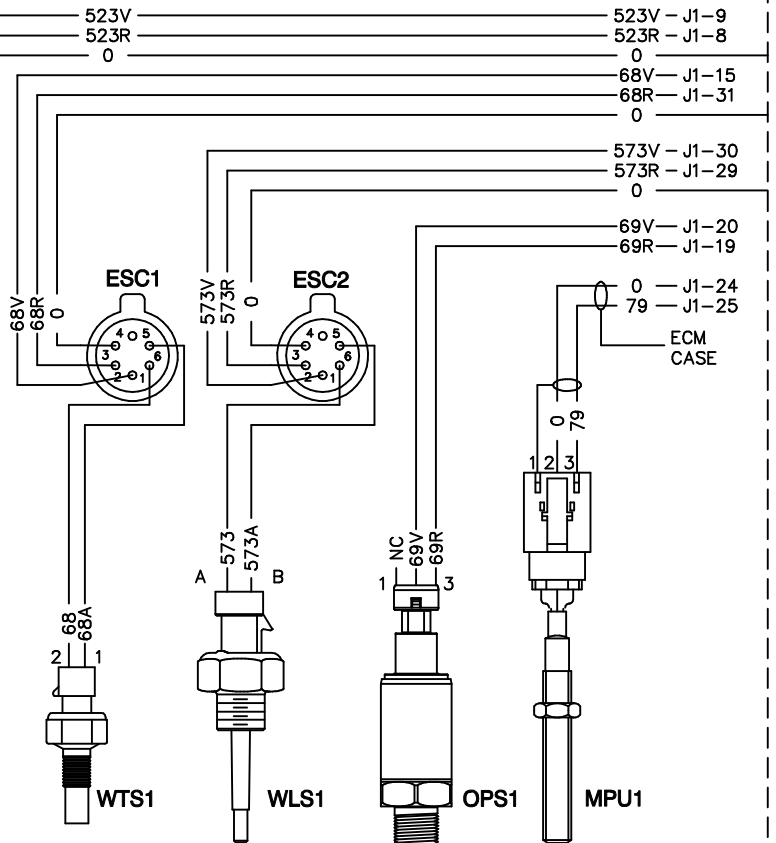
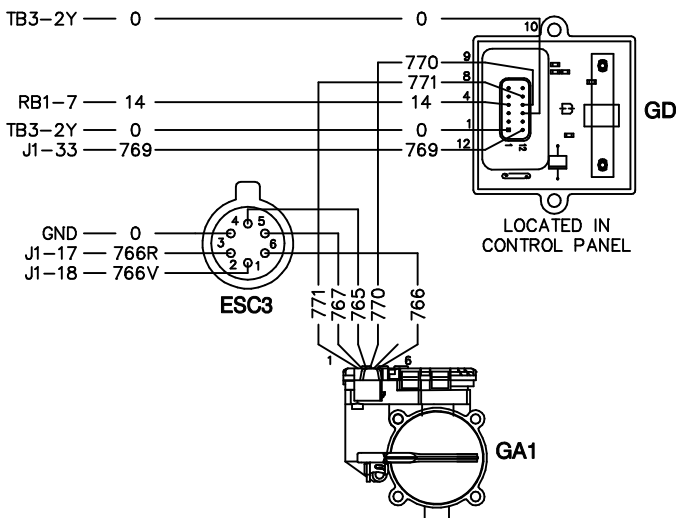

## COMPONENTS LOCATED ON ENGINE

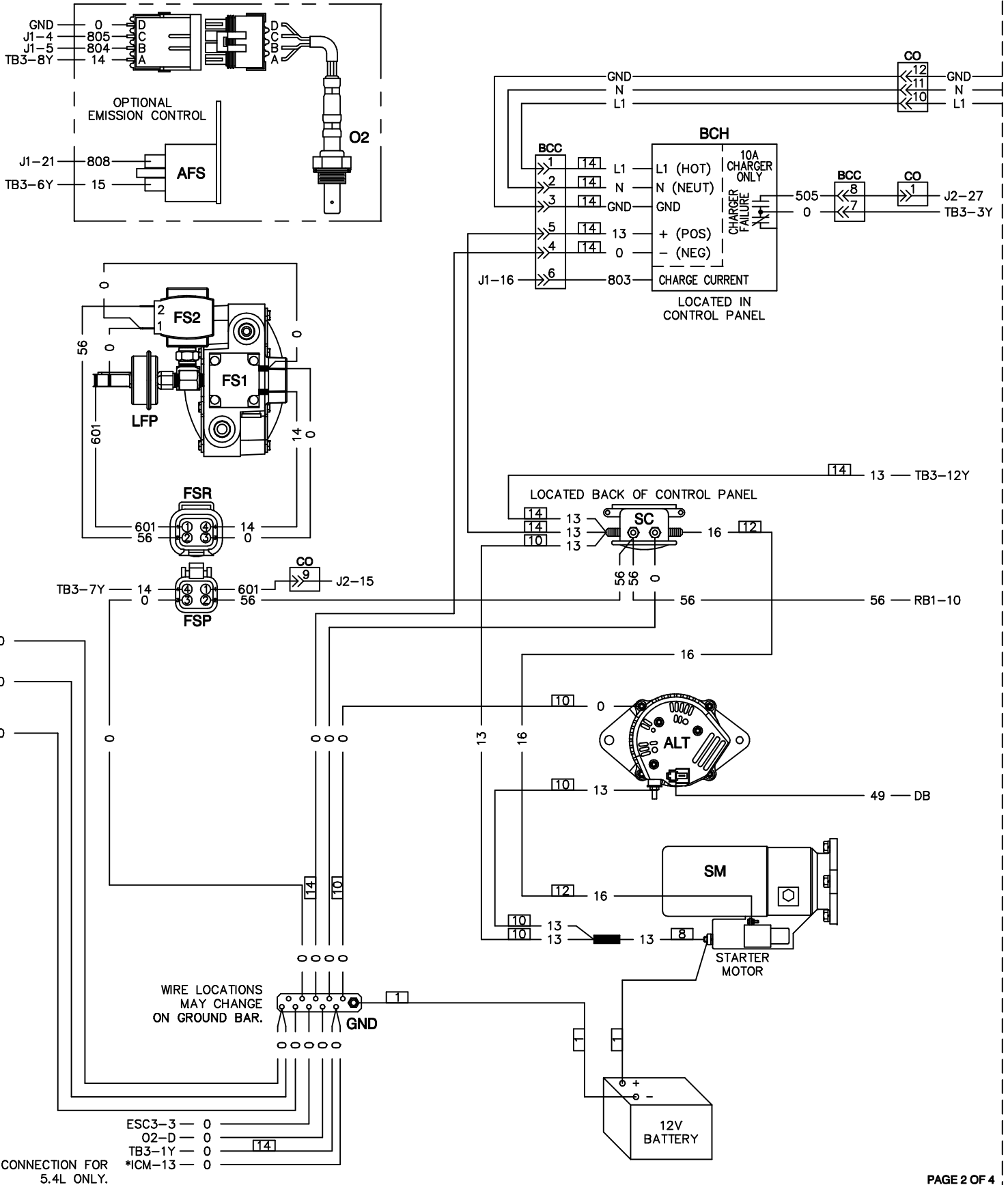

## COMPONENTS LOCATED IN ALTERNATOR CONNECTION BOX

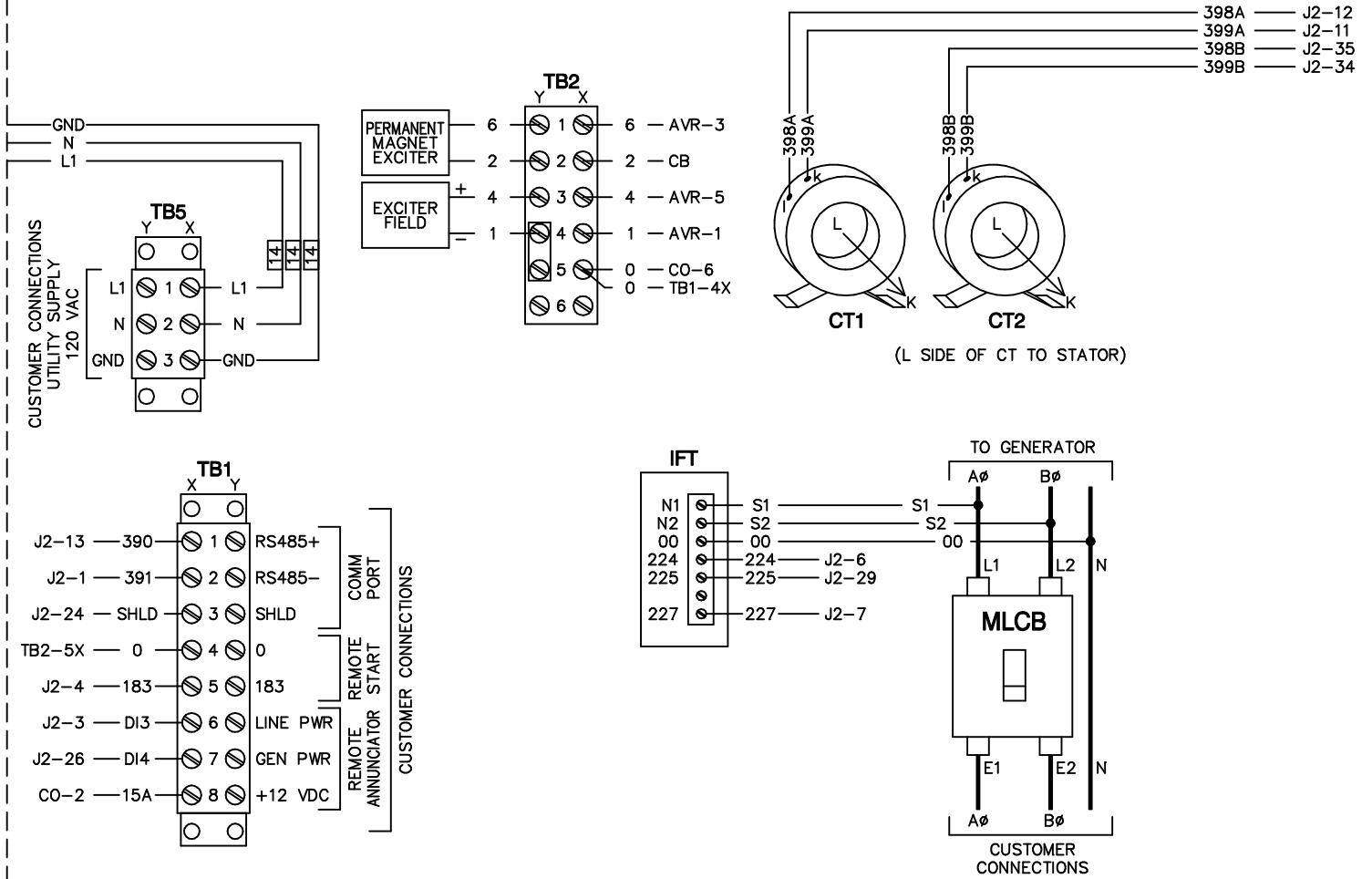

## COMPONENTS LOCATED IN CONTROL PANEL

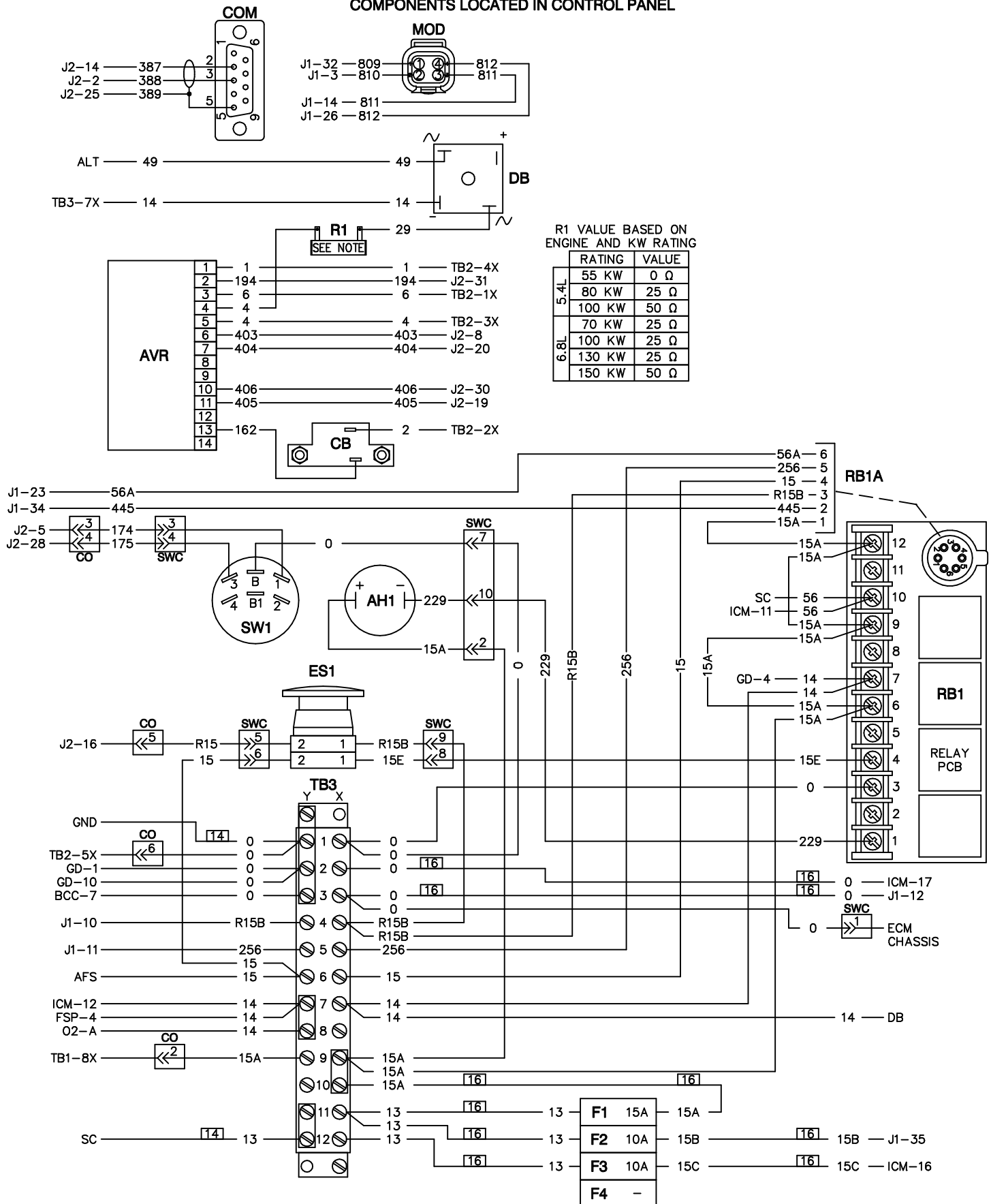

# GROUP G

| WEIGHT DATA   |                 |
|---|-----------------|
| 5. 4L 55KW -  | 895KG (1973 LB) |
| 6. 8L 70KW -  | 991KG (2185 LB) |
| WOODEN SHIPPING SKIDS INCREASE<br>OVERALL WEIGHT 79KG (175LB) |                 |

**NOTES:**

- 1) MINIMUM RECOMMENDED CONCRETE PAD SIZE: 1240 (48.8") WIDE X 2756 (108.5") LONG. REFERENCE INSTALLATION GUIDE SUPPLIED WITH UNIT FOR CONCRETE PAD GUIDELINES.
- 2) ALLOW SUFFICIENT ROOM ON ALL SIDES OF THE GENERATOR FOR MAINTENANCE AND SERVICING. THIS UNIT MUST BE INSTALLED IN ACCORDANCE WITH CURRENT APPLICABLE NFPA 37 AND NFPA 70 STANDARDS AS WELL AS ANY OTHER FEDERAL, STATE AND LOCAL CODES FOR MINIMUM DISTANCES FROM OTHER STRUCTURES.
- 3) CIRCUIT BREAKER INFORMATION:  
SEE SPECIFICATION SHEET WITHIN OWNERS MANUAL.
- 4) INSIDE STUB-UP AREA FOR AC LOAD LEAD CONDUIT CONNECTION, NEUTRAL CONNECTION, BATTERY CHARGER 120 VOLT AC (.5 AMP MAX.) CONNECTION, AND ACCESS TO TRANSFER SWITCH CONTROL WIRES. REMOVE FRONT COVER FOR ACCESS.
- 4A) FIELD CUT HOLE IS ONLY REQUIRED FOR MOUNTING OF GENERATOR ON AN EXISTING PAD.
- 5) REFERENCE OWNERS MANUAL FOR LIFTING WARNINGS.
- 6) REMOVE EITHER LEFT OR RIGHT HAND SIDE PANEL TO ACCESS EXHAUST MUFFLERS.

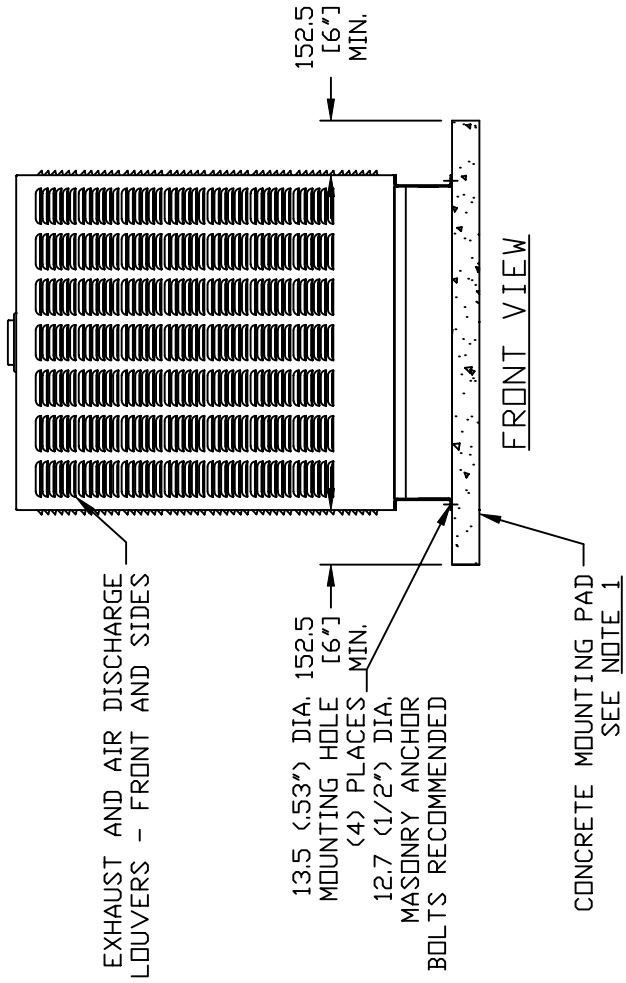



# GROUP G

## OPTION 1 - SINGLE PHASE, H-100 CONTROL PANEL

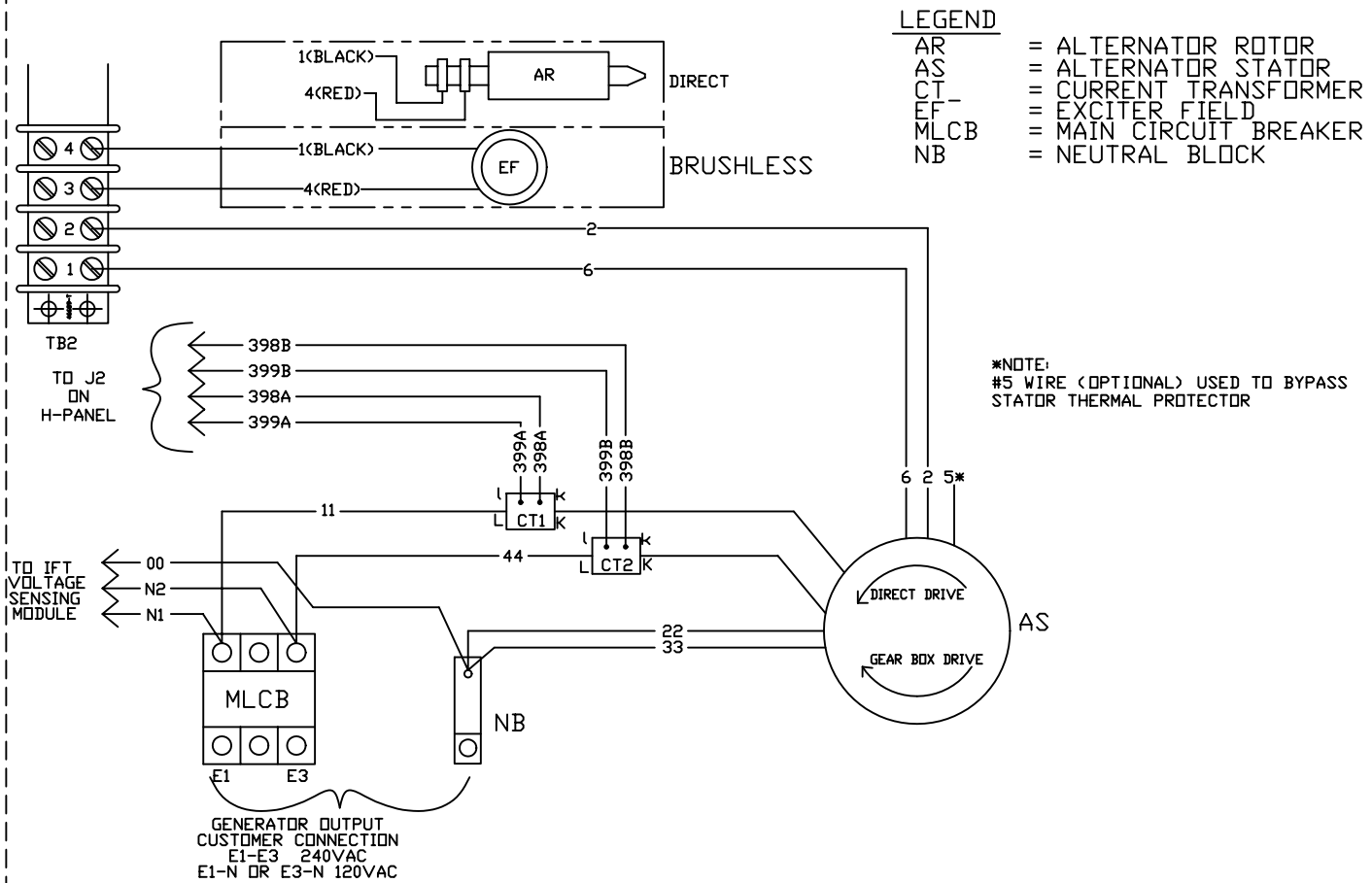



OPTION 2 - THREE PHASE, H-100 CONTROL PANEL DIRECT DRIVE, 6 LEAD

LEGEND

- AR = ALTERNATOR ROTOR
- AS = ALTERNATOR STATOR
- CT = CURRENT TRANSFORMER
- EF = EXCITER FIELD
- MLCB = MAIN CIRCUIT BREAKER
- NB = NEUTRAL BLOCK

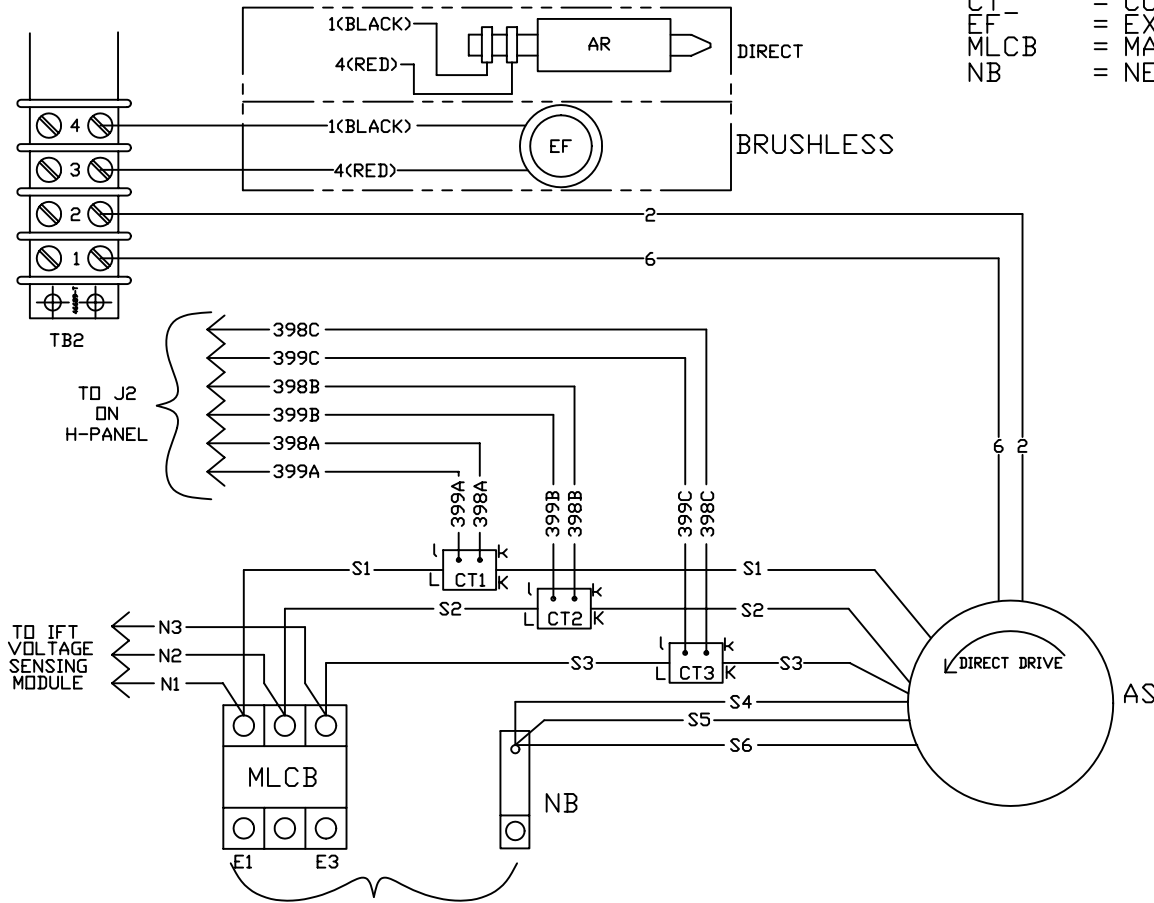

GENERATOR OUTPUT CUSTOMER CONNECTION

- E1 TO E2
- E2 TO E3 } \*208 OR 480VAC
- E1 TO E3

E1, E2, OR E3 TO NB = \* 120 OR 277VAC

\*NOTE: THE 8th DIGIT OF THE MODEL NUMBER SPECIFIES OUTPUT VOLTAGE

- \*G = 120/208VAC
- \*K = 277/480VAC

## OPTION 3 - THREE PHASE, H-100 CONTROL PANEL GEAR BOX (REVERSE ROTATION)

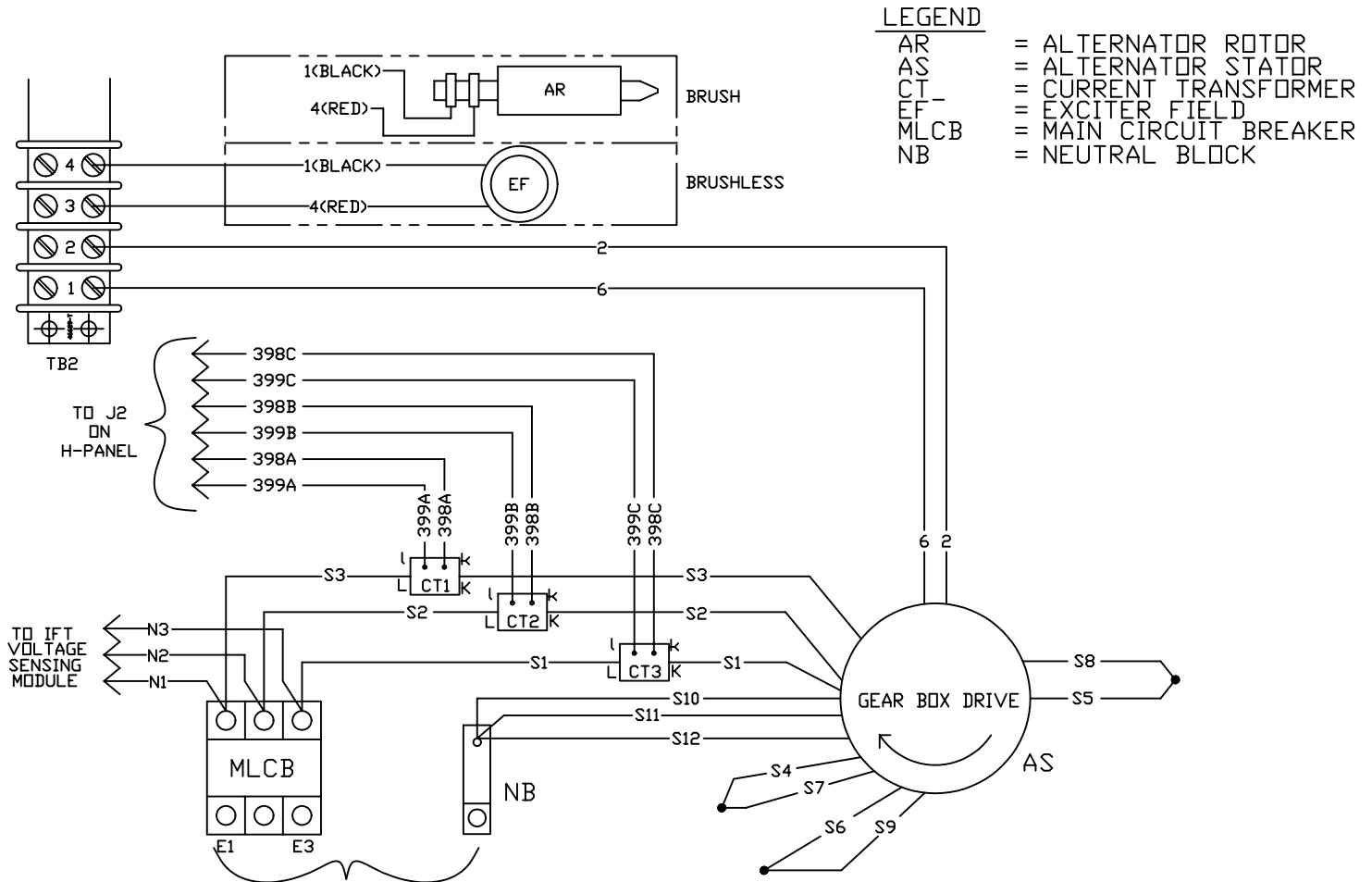

### LEGEND

- AR = ALTERNATOR ROTOR
- AS = ALTERNATOR STATOR
- CT = CURRENT TRANSFORMER
- EF = EXCITER FIELD
- MLCB = MAIN CIRCUIT BREAKER
- NB = NEUTRAL BLOCK

GENERATOR OUTPUT  
CUSTOMER CONNECTION

E1 TO E2 }  
E2 TO E3 } \*208 OR 480VAC  
E1 TO E3 }

E1, E2, OR E3 TO NB = \* 120 OR 277VAC

\*NOTE: THE 8<sup>th</sup> DIGIT OF THE MODEL NUMBER SPECIFIES OUTPUT VOLTAGE

\*G\* = 120/208VAC  
\*K\* = 277/480VAC

## OPTION 4 - THREE PHASE DELTA, H-100 CONTROL PANEL DIRECT DRIVE, 7 LEAD

### LEGEND

- AR = ALTERNATOR ROTOR
- AS = ALTERNATOR STATOR
- CT = CURRENT TRANSFORMER
- EF = EXCITER FIELD
- MLCB = MAIN CIRCUIT BREAKER
- NB = NEUTRAL BLOCK

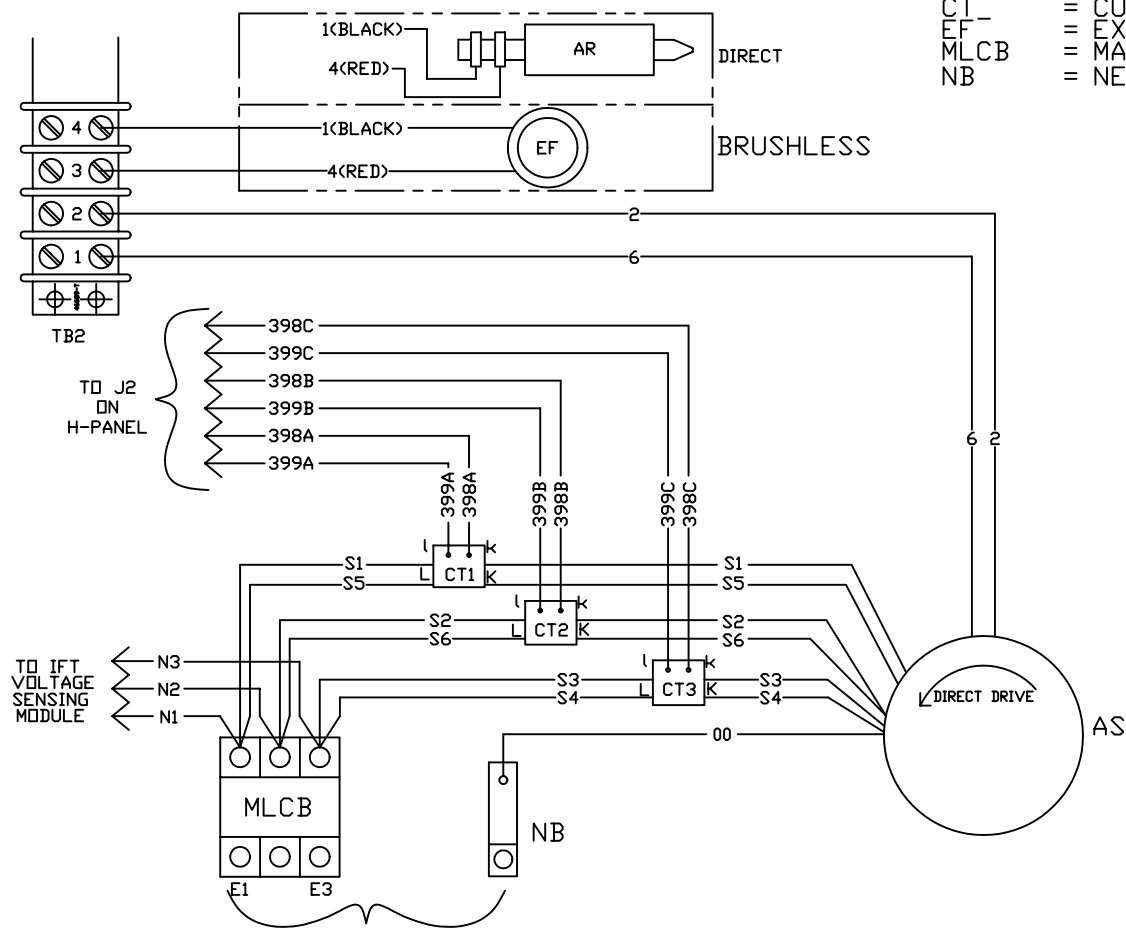

GENERATOR OUTPUT  
CUSTOMER CONNECTION  
E1 TO E2 } 240VAC  
E2 TO E3 }  
E1 TO E3 }

E1-N OR E3-N = 120VAC

\*NOTE: THE 8th DIGIT OF THE MODEL NUMBER SPECIFIES OUTPUT VOLTAGE  
\*J\* = 120/240VAC



## Standby Generator Sets Warranty



### GENERAC POWER SYSTEMS STANDARD LIMITED WARRANTY FOR COMMERCIAL PRODUCT 50kW AND ABOVE

For a period of two (2) years from the date of sale, or start-up by Authorized/Certified Generac Power Systems Dealer, or branch thereof, Generac Power Systems, Inc. will, at its option, repair or replace any part(s) which, upon examination, inspection, and testing by Generac Power Systems or an Authorized/Certified Generac Power Systems Dealer, or branch thereof, is found to be defective under normal use and service, in accordance with the warranty schedule set forth below. Any equipment that the purchaser/owner claims to be defective must be examined by the nearest Authorized/Certified Generac Power Systems Dealer, or branch thereof. This warranty applies only to Generac Power Systems Generators used in "Standby" applications, as Generac Power Systems, Inc. has defined Standby, provided said generator has been properly installed and inspected on-site by appropriate personnel. Scheduled maintenance, as outlined by the generator owner's manual, is highly recommended. This should be performed by an Authorized/ Certified Generac Power Systems Dealer, or branch thereof. This will verify service has been performed on the unit throughout the warranty period.

#### WARRANTY SCHEDULE

**YEAR ONE** — Limited comprehensive coverage on mileage, labor, and parts listed.

- - ALL COMPONENTS

**YEAR TWO** — Limited comprehensive coverage on parts listed.

- - ALL COMPONENTS

\*Start-up and/or On-line Registration, or Registration Card, along with Proof of Purchase, must be performed and/or sent in.

#### Guidelines:

- Any and all warranty repairs and/or concerns, must be performed and/or addressed by an Authorized/Certified Generac Power Systems Dealer, or branch thereof.
- A Generac Power Systems, Inc. Transfer Switch is highly recommended to be used in conjunction with the genset. If a Non - Generac Power Systems, Inc. Transfer Switch is substituted for use and directly causes damage to the genset, no warranty coverage shall apply.
- All warranty expense allowances are subject to the conditions defined in Generac Power Systems Warranty, Policies, and Procedures Flat Rate Manual.
- Units that have been resold are not covered under the Generac Power Systems Warranty, as this Warranty is not transferable.
- Unit enclosure is only covered against rust or corrosion the first year of the warranty provision.
- Use of Non-Generac replacement part(s) will void the warranty in its entirety.
- Engine coolant heaters (block-heaters), heater controls and circulating pumps are only covered during the first year of the warranty provision (If applicable).

#### THIS WARRANTY SHALL NOT APPLY TO THE FOLLOWING:

1. Any unit built/manufactured prior to March 1, 2005.
2. Costs of normal maintenance (i.e. tune-ups, associated part(s), adjustments, loose/leaking clamps, installation and start-up).
3. Any failure caused by contaminated fuels, oils, coolants/antifreeze or lack of proper fuels, oils or coolants/antifreeze.
4. Units sold, rated or used for "Prime Power", "Trailer Mounted" or "Rental Unit" applications as Generac Power Systems have defined Prime Power, Trailer Mounted or Rental Unit. Contact a Generac Power Systems Distributor for Prime Power, Trailer Mounted or Rental Unit definition and warranty.
5. Units used for prime power in place of existing utility power where utility is present or in place of utility power where utility power service does not normally exist.
6. Failures caused by any external cause or act of God such as, but not limited to, collision, fire, theft, freezing, vandalism, riot or wars, lightning, earthquake, windstorm, hail, volcanic eruption, water or flood, tornado, hurricane, terrorist acts or nuclear holocaust.
7. Products that are modified or altered in a manner not authorized by Generac Power Systems in writing.
8. Failures due, but not limited to, normal wear and tear, accident, misuse, abuse, negligence, or improper installation or sizing.
9. Any incidental, consequential or indirect damages caused by defects in materials or workmanship, or any delay in repair or replacement of the defective part(s).
10. Failure due to misapplication, misrepresentation, or bi-fuel conversion.
11. Telephone, facsimile, cell phone, satellite, internet, or any other communication expenses.
12. Rental equipment used while warranty repairs are being performed (i.e. rental generators, cranes, etc.).
13. Overtime, holiday, or emergency labor.
14. Planes, ferries, railroad, busses, helicopters, snowmobiles, snow-cats, off-road vehicle or any other mode of transportation deemed abnormal.
15. Any and all expenses incurred investigating performance complaints unless defective Generac materials and/or workmanship were the direct cause of the problem.
16. Starting batteries, fuses, light bulbs, engine fluids, and overnight freight cost for replacement part(s).

THIS WARRANTY IS IN PLACE OF ALL OTHER WARRANTIES, EXPRESSED OR IMPLIED, SPECIFICALLY, GENERAC POWER SYSTEMS MAKES NO OTHER WARRANTIES AS TO THE MERCHANTABILITY OR FITNESS FOR A PARTICULAR PURPOSE. Some states do not allow limitations on how long an implied warranty lasts, so the above limitation may not apply to purchaser/owner.

GENERAC POWER SYSTEMS ONLY LIABILITY SHALL BE THE REPAIR OR REPLACEMENT OF PART(S) AS STATED ABOVE. IN NO EVENT SHALL GENERAC POWER SYSTEMS BE LIABLE FOR ANY INCIDENTAL, OR CONSEQUENTIAL DAMAGES, EVEN IF SUCH DAMAGES ARE A DIRECT RESULT OF GENERAC POWER SYSTEMS, INC. NEGLIGENCE.

Some states do not allow the exclusion or limitation of incidental or consequential damages, so the above limitations may not apply to purchaser/owner. Purchaser/owner agrees to make no claims against Generac Power Systems, Inc. based on negligence. This warranty gives purchaser/owner specific legal rights. Purchaser/owner also may have other rights that vary from state to state

**Generac Power Systems, Inc. · P.O. Box 8 · Waukesha, WI 53187**  
**Ph: (262) 544-4811 · Fax: (262) 544-4851**

Bulletin 0171370SVE / Printed in U.S.A. 7.05