

## MOBY<sup>®</sup> I

### Configuration, Installation and Service

#### Manual

#### Table of Contents

---

General

---

**1**

Introduction to MOBY I

---

**2**

Configuration and Mounting Guidelines

---

**3**

Mobile Data Memories

---

**4**

Read/Write Devices

---

**5**

Interfaces

---

**6**

Accessories

---

**7**

Documentation

---

**A**

Error Messages

---

**B**

ASCII Table

---

**C**

Compatibility

**D**

## Safety Guidelines

This manual contains notices which you should observe to ensure your own personal safety, as well as to protect the product and connected equipment. These notices are highlighted in the manual by a warning triangle and are marked as follows according to the level of danger.

---



### Danger

indicates that death, severe personal injury or substantial property damage **will** result if proper precautions are not taken.

---



### Warning

indicates that death, severe personal injury or substantial property damage **can** result if proper precautions are not taken.

---



### Caution

indicates that minor personal injury or property damage can result if proper precautions are not taken.

---

### Note

draws your attention to particularly important information on the product, handling the product, or to a particular part of the documentation.

---

## Qualified Personnel

Only **qualified personnel** should be allowed to install and work on this equipment. For the purposes of the safety notes contained in this manual; qualified persons are defined as persons who are authorized to commission, to ground, and to tag circuits, equipment, and systems in accordance with established safety practices and standards.

## Correct Usage

Note the following.

---



### Warning

This device and its components may only be used for the applications described in the catalog or the technical description, and only in connection with devices or components from other manufacturers which have been approved or recommended by Siemens.

This product can only function correctly and safely if it is transported, stored, set up, and installed correctly, and operated and maintained as recommended.

---

## Trademarks

MOBY®, SIMATIC® and SINEC® are registered trademarks of SIEMENS AG.

Some of the other designations used in this documentation are also registered trademarks; the owner's rights may be violated if they are used by third parties for their own purposes.

### Copyright © Siemens AG 1997 All rights reserved

The reproduction, transmission or use of this document or its contents is not permitted without express written authority. Offenders will be liable for damages. All rights, including rights created by patent grant or registration of a utility model or design, are reserved.

Siemens AG  
Automation and Drives  
Systems Engineering  
Postfach 23 55, D-90713 Fuerth

### Disclaimer of Liability

We have checked the contents of this manual for agreement with the hardware and software described. Since deviations cannot be precluded entirely, we cannot guarantee full agreement. However, the data in this manual are reviewed regularly and any necessary corrections included in subsequent editions. Suggestions for improvement are welcomed.

© Siemens AG 1997, 1998, 1999, 2000, 2001, 2002  
Technical data subject to change

# Configuration and Mounting Guidelines

# 3

## 3.1 Basic Requirements



---

### Warning

Do not make changes to the devices.  
Violation will invalidate interference emission certification (BZT, FCC), CE and the manufacturer's warranty.

---

### FCC Compliance Statement

---

### Note

Any unauthorized modifications to this device could void the user's authority to operate the equipment.

---

To choose the correct MOBY I components, apply the following criteria to your particular application.

- Transmission distance (i.e., read/write distance)
- The amount of data to be transferred
- Metal-free spaces for MDS and SLG
- Static or dynamic transmission of the data
- Speed for dynamic transmission
- Tolerances of the tracking
- Environmental conditions (e.g., moisture, temperature, chemical influences and so on)

## 5.4 SLG 41/SLG 41-S

### Application area

The SLG 41 is a low-end read/write device. It is particularly suitable for use when the MDS conveyor system (e.g., pallets) can be physically positioned relatively precisely. The swivel head of the SLG 41 makes it very adaptable to the transportation system.

In dynamic operation, only a small amount of data can be read or written between SLG 41 and MDS.

In contrast to the SLG 41, the antenna of the SLG 41-S is rotated by 90° in the swivel head so that all positions of the transmission window can be implemented.

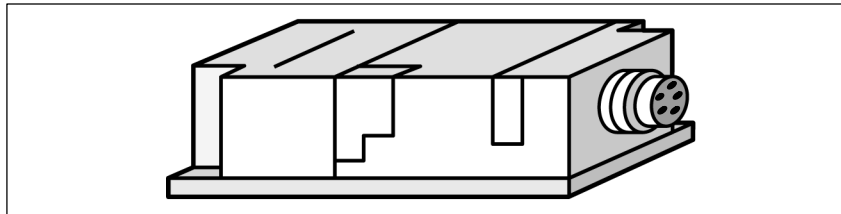

Figure 5-12 SLG 41

### Ordering data

Table 5-8 Ordering data for SLG 41/SLG 41-S

Read/write device up to 25 mm	
SLG 41	6GT2 001-0AA00
SLG 41-S (antenna turned 90°)	6GT2 001-0AA00-ZA23
SLG plug connector and stub lines	See chapter 3.10

### Technical data

Table 5-9 Technical data of SLG 41/SLG 41-S

Inductive interface to MDS	
Data transmission speed	19200 baud
Read/write distance SLG to MDS (max.)	30 mm (see field data table)
Transmission frequency	
• Power	134 kHz
• Data	1.81 MHz
Serial interface to ASM	6-pin SLG plug connector in acc. w. DIN 43651
Transmission speed	19200 baud, RS 422
Line length, ASM to SLG (max.) at 24 V DC	360 m
Supply voltage (via serial interface)	
Nominal value	24 V DC
Permissible range	20 to 30 V DC

Table 5-9 Technical data of SLG 41/SLG 41-S

Current consumption	
Idle/operation	20 mA / 90 mA
MTBF	2 x 10 <sup>6</sup>
Housing	
Dimensions in mm (W x H x D)	120 x 40 x 40
Color	Anthracite/ergo-gray
Material	Polyamide 12
Plug connection	DIN 43651
Protection rating	IP65
Shock	50 g
Vibration	20 g
Mounting of SLG	4 M5 screws
Turning moment (at room temperature)	≤ 3 Nm
Ambient temperature	
During operation	-25° to +70° C
During transportation and storage	-40° to +85° C
Weight (approx.)	210 g

**Field data**

The exact field data are dependent on the type of MDS used.

Table 5-10 Field data of SLG 41/SLG 41-S

Operating distance (S <sub>a</sub> )	0 to 15 mm
Limit distance (S <sub>g</sub> )	30 mm
Median deviation (L)	Depends on MDS
Minimum distance from SLG to SLG (D)	> 200 mm

**FCC information****Made in Germany****SIEMENS MOBY I SLG 41**

THIS DEVICE COMPLIES WITH PART 15 OF THE FCC RULES: OPERATION IS SUBJECT TO THE FOLLOWING TWO CONDITIONS:

(1) THIS DEVICE MAY NOT CAUSE HARMFUL INTERFERENCE, AND (2) THIS DEVICE MUST ACCEPT ANY INTERFERENCE THAT MAY CAUSE UNDESIRE OPERATION.

**Note**

The manufacturer is not responsible for any radio or TV interference caused by unauthorized modifications to this equipment:  
Such modifications could void the user's authority to operate the equipment.

**Transmission window**

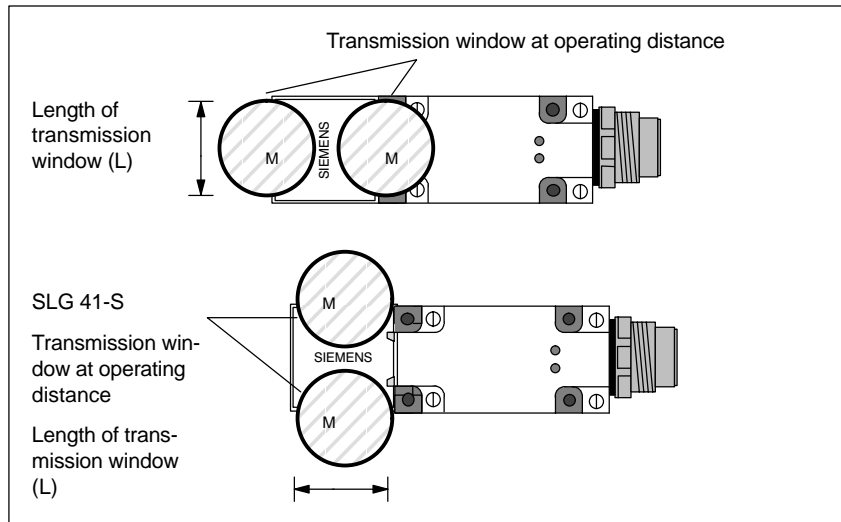

Figure 5-13 Transmission window of SLG 41/SLG 41-S

**Metal-free space**

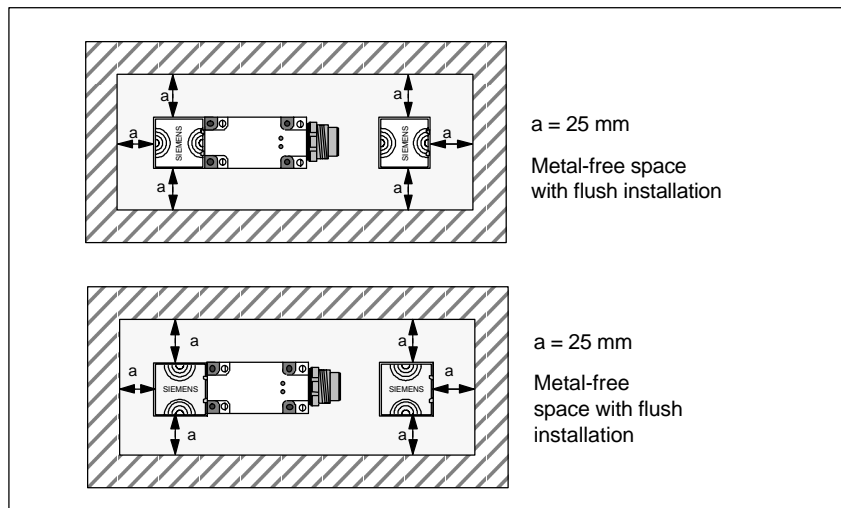

Figure 5-14 Metal-free space for SLG 41/SLG 41-S

**Definition of distance D**

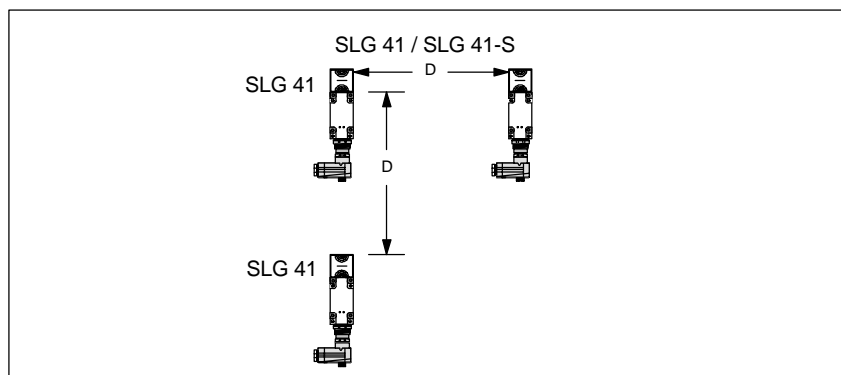

Figure 5-15 Distance D for SLG 41/SLG 41-S

**Dimensions  
(in mm)**

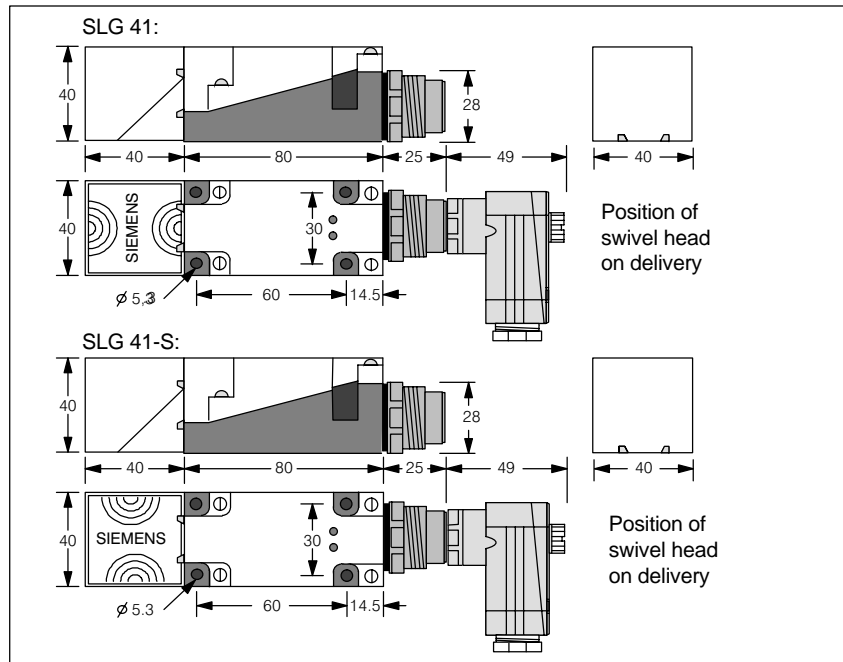

Figure 5-16 Dimensional diagram of SLG 41/SLG 41-S

**Possible read head  
changes with the  
swivel head**

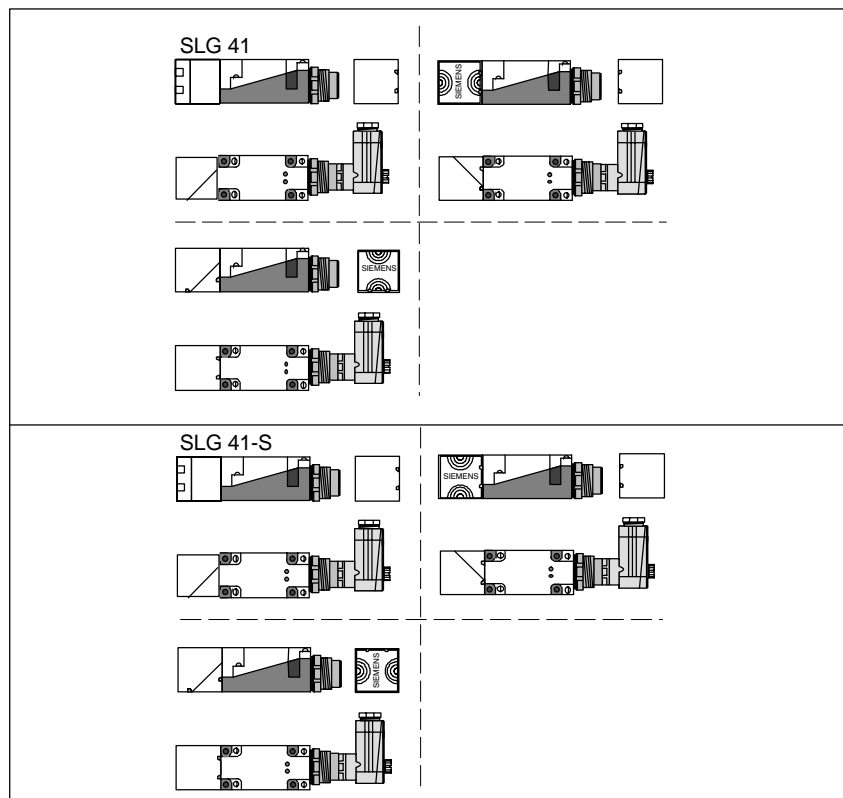

Figure 5-17 Read head changes of SLG 41/SLG 41-S



## 5.5 SLG 41C/SLG 41CC

### Application area

The SLG 41C is a low-end read/write device. It is small and compact and is excellent for use in small assembly lines.

The high protection rating and use of high-quality materials ensure that the SLG 41C can easily handle even most rugged industrial conditions.

It is connected with a 3-m cable which is equipped with core sleeves at the end. This connection line can be extended with terminals or a user-provided connection plug. This connection plug of the ASM is used for the connection to the ASM.

The cable length of the SLG 41CC is 2 m. The end of the cable is equipped with a twin M-12 plug. This can be used to connect the SLG 41CC directly to an ASM 450/452/473.

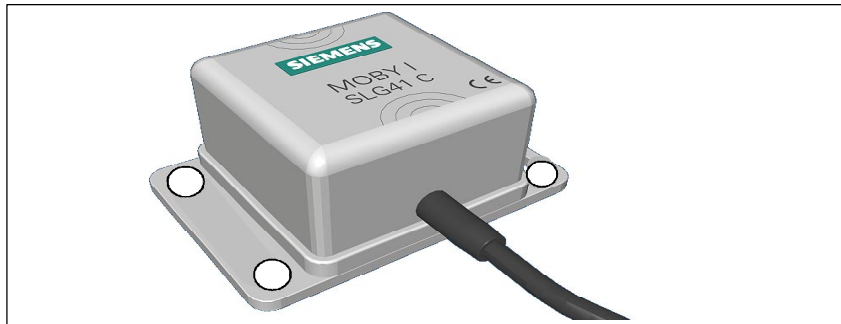

Figure 5-18 SLG 41C/41CC read/write device

### Ordering data

Table 5-11 Ordering data of SLG 41C/41CC

Read/write device SLG 41C	6GT2 001-0AC00
SLG 41CC read/write device with twin M-12 plug	6GT2 001-0AC00-0AX0
Accessories:	
Extension cable (not fabricated)	6GT2 090-0A...
Connection plug for ASM 450/473	6GT2 090-0BC00

### Technical data

Table 5-12 Technical data of SLG 41C/41CC

Inductive interface to MDS	
Read/write distance, SLG-MDS, max.	30 mm (see field data)
Transmission frequency	
Power	134 kHz
Data	1.81MHz

Table 5-12 Technical data of SLG 41C/41CC

Serial interface to evaluation unit	RS 422
Data transmission rate	19 200 Baud
Line length, ASM-SLG max. (for 24V DC)	360 m
Serial interface to user	
SLG 41C	3 m connection line; open end
SLG 41CC	2 m connection line; twin M-12 plug for ASM 450/452/473
Voltage	
Nominal value	24 V DC
Permissible range	20 V to 30 V DC
Current consumption at room temperature	
Standby	30 mA
Operation	70 mA (typical)
Housing	
Dimensions (L x W x H) in mm	55 x 75 x 30
Color	Gray
Material	Plastic (polyamide 12)
Connection	3 m connection line, cable ends with core sleeves and labels
Protection rating an acc. w. EN 60 529	IP67
Shock	50 g
Vibration	20 g
Mounting of SLG	4 M 5 screws
Tightening moment (at room temperature)	< 2 Nm
Ambient temperature	
During operation	-25° C to +70° C
During transposition and storage	-40° C to +85° C
Weight approx.	210 g

**Field data (in mm)**

Table 5-13 Field data of SLG 41C/41CC

	<b>MDS 401/402</b>	<b>MDS 403</b>	<b>MDS 404/514</b>
Working distance ( $S_a$ )	0 to 6	4 to 15	0 to 12
Limit distance ( $S_g$ )	10	30	25
Transmission window			
• L: Vertical	20	65	30
• 2L: Horizontal	40	–	60
Width of transmission window (W)	8	25	12
Minimum distance from SLG to SLG	$\geq 200$	$\geq 200$	$\geq 200$

**FCC information**

Made in Germany

SIEMENS MOBY I SLG 41C

THIS DEVICE COMPLIES WITH PART 15 OF THE FCC RULES: OPERATION IS SUBJECT TO THE FOLLOWING TWO CONDITIONS:

(1) THIS DEVICE MAY NOT CAUSE HARMFUL INTERFERENCE, AND (2) THIS DEVICE MUST ACCEPT ANY INTERFERENCE THAT MAY CAUSE UNDESIRE OPERATION.

**Note**

The manufacturer is not responsible for any radio or TV interference caused by unauthorized modifications to this equipment:  
Such modifications could void the user's authority to operate the equipment.

**Transmission window**

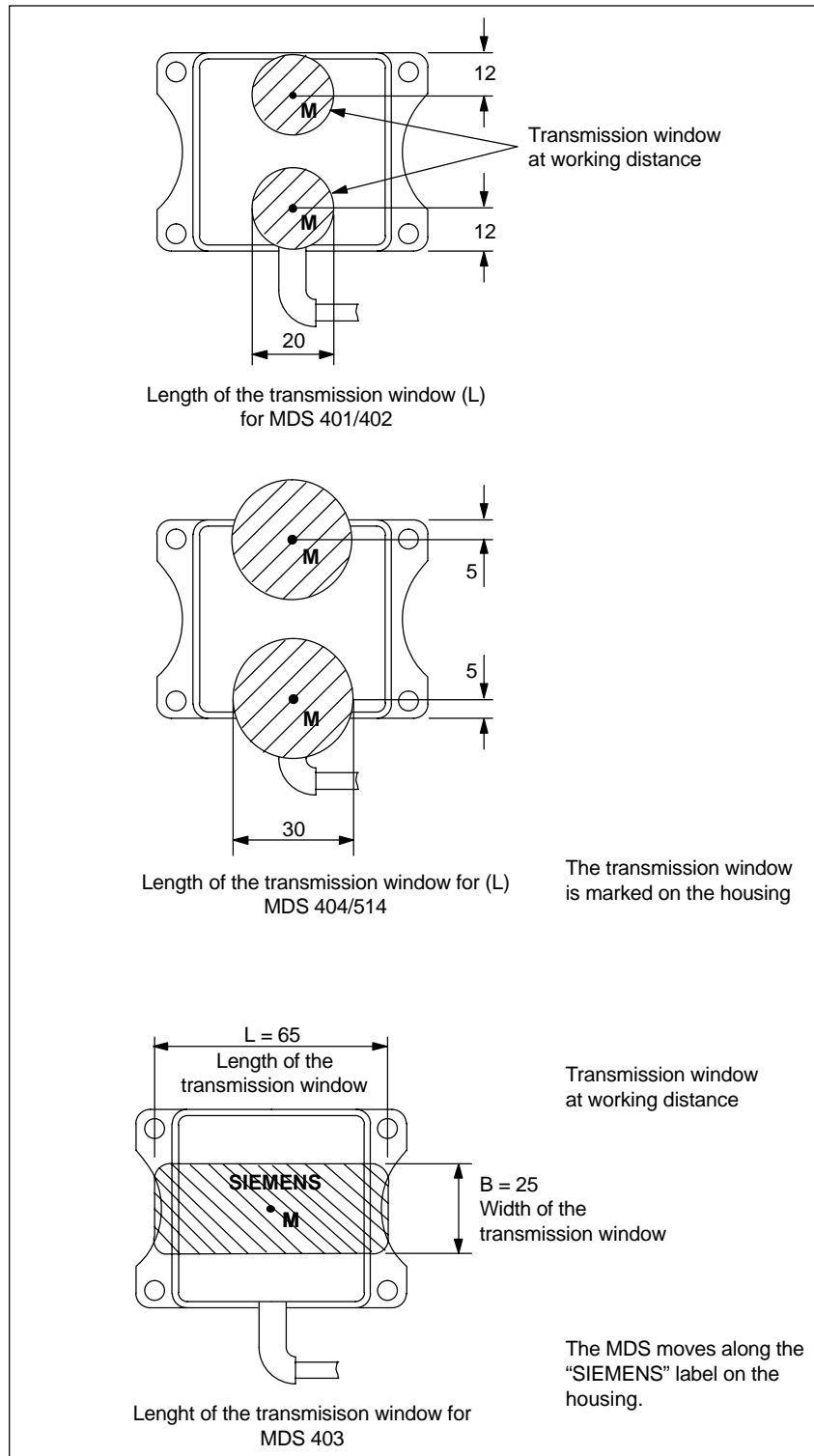

Figure 5-19 Transmission window of SLG 41C/41CC

**Metal-free space**

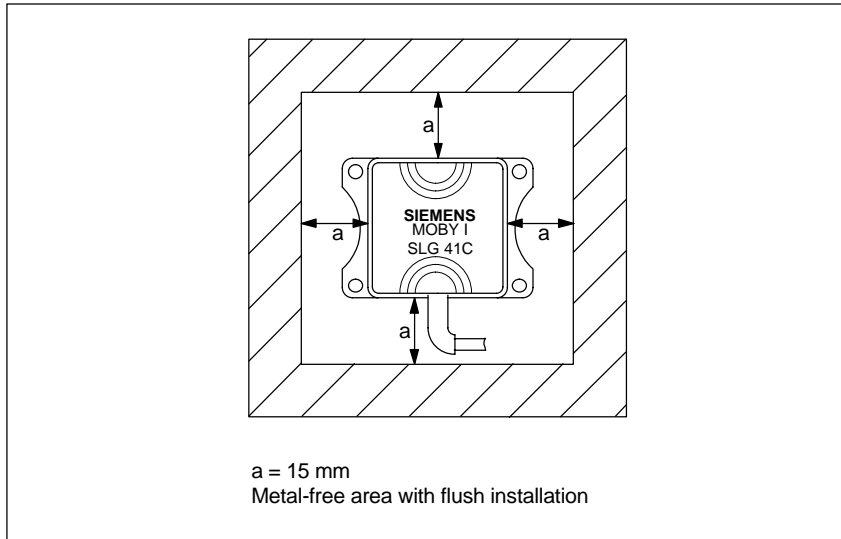

Figure 5-20 Metal-free area of SLG 41C/41CC

**Definition of distance D**

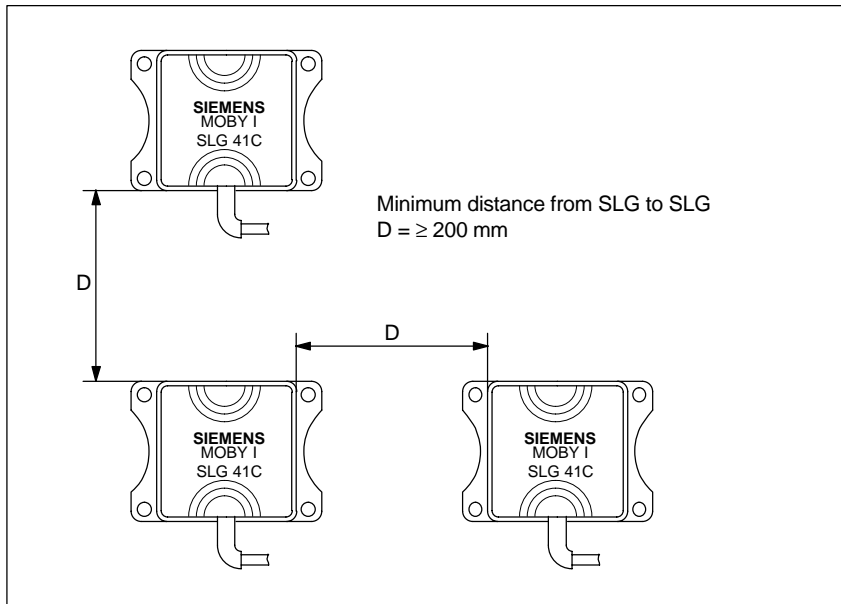

Figure 5-21 Distance D: SLG 41C/41CC

**Dimensions  
(in mm)**

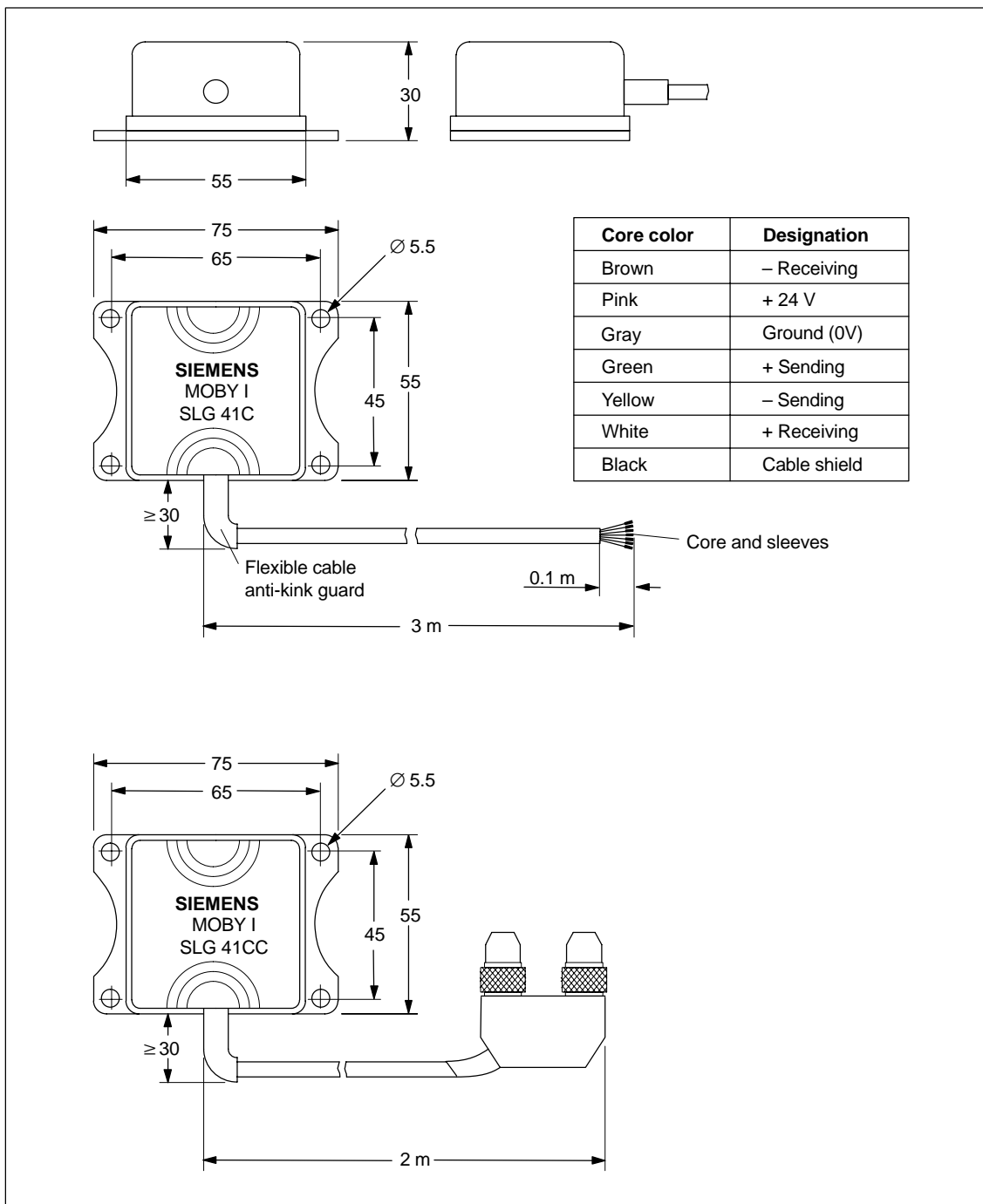

Figure 5-22 Dimensions of SLG 41C/41CC