

SIEMENS

SIMATIC Ident

RFID systems SIMATIC RF200

System Manual

<u>Introduction</u>	1
<u>Safety notes</u>	2
<u>System overview</u>	3
<u>Planning the RF200 system</u>	4
<u>Readers</u>	5
<u>Antennas</u>	6
<u>Transponder</u>	7
<u>System integration</u>	8
<u>System diagnostics</u>	9
<u>Appendix</u>	A

Legal information

Warning notice system

This manual contains notices you have to observe in order to ensure your personal safety, as well as to prevent damage to property. The notices referring to your personal safety are highlighted in the manual by a safety alert symbol, notices referring only to property damage have no safety alert symbol. These notices shown below are graded according to the degree of danger.

⚠ DANGER
indicates that death or severe personal injury will result if proper precautions are not taken.
⚠ WARNING
indicates that death or severe personal injury may result if proper precautions are not taken.
⚠ CAUTION
indicates that minor personal injury can result if proper precautions are not taken.
NOTICE
indicates that property damage can result if proper precautions are not taken.

If more than one degree of danger is present, the warning notice representing the highest degree of danger will be used. A notice warning of injury to persons with a safety alert symbol may also include a warning relating to property damage.

Qualified Personnel

The product/system described in this documentation may be operated only by **personnel qualified** for the specific task in accordance with the relevant documentation, in particular its warning notices and safety instructions. Qualified personnel are those who, based on their training and experience, are capable of identifying risks and avoiding potential hazards when working with these products/systems.

Proper use of Siemens products

Note the following:

⚠ WARNING
Siemens products may only be used for the applications described in the catalog and in the relevant technical documentation. If products and components from other manufacturers are used, these must be recommended or approved by Siemens. Proper transport, storage, installation, assembly, commissioning, operation and maintenance are required to ensure that the products operate safely and without any problems. The permissible ambient conditions must be complied with. The information in the relevant documentation must be observed.

Trademarks

All names identified by ® are registered trademarks of Siemens AG. The remaining trademarks in this publication may be trademarks whose use by third parties for their own purposes could violate the rights of the owner.

Disclaimer of Liability

We have reviewed the contents of this publication to ensure consistency with the hardware and software described. Since variance cannot be precluded entirely, we cannot guarantee full consistency. However, the information in this publication is reviewed regularly and any necessary corrections are included in subsequent editions.

Table of contents

1	Introduction	13
1.1	Abbreviations and naming conventions.....	14
2	Safety notes	15
3	System overview	19
3.1	RFID components and their function.....	20
3.2	Overview of transponders.....	23
4	Planning the RF200 system	27
4.1	Fundamentals of application planning.....	27
4.1.1	Selection criteria for SIMATIC RF200 components.....	27
4.1.2	Transmission window and read/write distance.....	27
4.1.3	Width of the transmission window.....	30
4.1.4	Impact of secondary fields.....	31
4.1.5	Permissible directions of motion of the transponder.....	34
4.1.6	Operation in static and dynamic mode.....	35
4.1.7	Dwell time of the transponder.....	36
4.1.8	Communication between communication module, reader and transponder.....	37
4.2	Field data of transponders and readers.....	38
4.2.1	Field data.....	39
4.2.2	Minimum clearances.....	48
4.3	Installation guidelines.....	50
4.3.1	Overview.....	50
4.3.2	Reduction of interference due to metal.....	51
4.3.3	Effects of metal on different transponders and readers.....	53
4.3.4	Impact of metal on the transmission window.....	54
4.3.4.1	RF210R.....	55
4.3.4.2	RF220R.....	58
4.3.4.3	RF240R.....	60
4.3.4.4	RF250R.....	63
4.3.4.5	RF260R.....	71
4.3.4.6	RF280R.....	74
4.3.4.7	RF290R.....	76
4.3.5	Installation and connection of 2 to 6 antennas with one RF290R reader.....	80
4.3.5.1	Installation options with the antenna splitter (2-4 antennas).....	80
4.3.5.2	Antenna installation.....	84
4.3.5.3	Installation options with the antenna multiplexer (2-6 antennas).....	88
4.3.6	Chemical resistance of the reader and transponders.....	89
4.3.6.1	Readers.....	89
4.3.6.2	Transponder.....	93
4.4	Further information.....	101

5	Readers	103
5.1	SIMATIC RF210R	104
5.1.1	Features	104
5.1.2	RF210R ordering data	104
5.1.3	Pin assignment RF210R with RS422 interface	105
5.1.4	LED operating display	105
5.1.5	Minimum distance between RF210R readers	106
5.1.6	Technical specifications of the RF210R reader	107
5.1.7	Approvals	108
5.1.8	Dimension drawing	109
5.2	SIMATIC RF210M	110
5.2.1	Features	110
5.2.2	Ordering data RF210M	110
5.2.3	Installing the RF210M reader	111
5.2.4	Pin assignment RF210M with RS-422 interface	112
5.2.5	LED operating display	112
5.2.6	Technical specifications of the RF210M reader	113
5.2.7	Approvals	114
5.2.8	Dimension drawing	115
5.3	SIMATIC RF220R	116
5.3.1	Features	116
5.3.2	RF220R ordering data	116
5.3.3	RF220R pin assignment with RS422 interface	117
5.3.4	LED operating display	117
5.3.5	Minimum distance between RF220R readers	118
5.3.6	Technical specifications of the RF220R reader	119
5.3.7	Approvals	120
5.3.8	Dimension drawing	121
5.4	SIMATIC RF240R	122
5.4.1	Features	122
5.4.2	RF240R ordering data	122
5.4.3	Pin assignment RF240R	123
5.4.4	LED operating display	123
5.4.5	Minimum distance between several RF240R readers	124
5.4.6	Technical specifications of the RF240R reader	125
5.4.7	Approvals	127
5.4.8	Dimension drawing	128
5.5	SIMATIC RF250R	128
5.5.1	Features	128
5.5.2	Ordering data RF250R	129
5.5.3	Pin assignment RF250R	129
5.5.4	LED operating display	129
5.5.5	Technical specifications of the RF250R reader	130
5.5.6	Approvals	131
5.5.7	Dimension drawing	133
5.6	SIMATIC RF260R	134
5.6.1	Features	134
5.6.2	Ordering data for RF260R	134
5.6.3	Pin assignment RF260R	135

5.6.4	LED operating display	135
5.6.5	Minimum distance between several RF260R	136
5.6.6	Technical data of the RF260R reader.....	137
5.6.7	Approvals	138
5.6.8	Dimension drawing	139
5.7	SIMATIC RF280R	140
5.7.1	Features	140
5.7.2	Ordering data RF280R.....	140
5.7.3	Pin assignment RF280R.....	141
5.7.4	LED operating display.....	141
5.7.5	Minimum distance between RF280R readers	142
5.7.6	Technical specifications of the RF280R reader	143
5.7.7	Approvals	144
5.7.8	Dimension drawing	146
5.8	SIMATIC RF290R	147
5.8.1	Features	147
5.8.2	Ordering data RF290R.....	147
5.8.3	Pin assignment RF290R.....	149
5.8.4	LED operating display.....	151
5.8.5	Installing the RF290R reader.....	152
5.8.5.1	Wall mounting	152
5.8.5.2	Installing on the S7-300 standard rail	153
5.8.5.3	Installation on a DIN rail.....	153
5.8.6	Technical specifications of the RF290R reader	155
5.8.7	Approvals	156
5.8.8	Note on the use of the RF290R as a replacement for SLG D10 / SLG D10S.....	158
5.8.9	Dimension drawing	159
6	Antennas	161
6.1	ANT 1	161
6.1.1	Characteristics	161
6.1.2	Ordering data	161
6.1.3	Flush-mounted in metal	162
6.1.4	Operating / limit distances	162
6.1.5	Minimum clearances.....	163
6.1.6	Technical specifications.....	164
6.1.7	Dimension drawing	165
6.2	ANT 3.....	166
6.2.1	Features.....	166
6.2.2	Ordering data	166
6.2.3	Mounting on/in metal.....	167
6.2.4	Operating / limit distances	168
6.2.5	Minimum spacing	169
6.2.6	Technical data.....	170
6.2.7	Dimension drawing	171
6.3	ANT 8.....	172
6.3.1	Features.....	172
6.3.2	Ordering data	172
6.3.3	Transmission window.....	173
6.3.4	Flush-mounted in metal	173

6.3.5	Minimum spacing	174
6.3.6	Technical data	175
6.3.7	Dimension drawing	176
6.4	ANT 12	177
6.4.1	Features	177
6.4.2	Ordering data	177
6.4.3	Transmission window.....	178
6.4.4	Flush-mounted in metal	178
6.4.5	Minimum spacing	179
6.4.6	Technical data	180
6.4.7	Dimension drawing	181
6.5	ANT 18	182
6.5.1	Features	182
6.5.2	Ordering data	182
6.5.3	Transmission window.....	183
6.5.4	Flush-mounted in metal	183
6.5.5	Minimum spacing	184
6.5.6	Technical data	185
6.5.7	Dimension drawing	186
6.6	ANT 30	187
6.6.1	Features	187
6.6.2	Ordering data	187
6.6.3	Transmission window.....	188
6.6.4	Flush-mounted in metal	189
6.6.5	Minimum spacing	189
6.6.6	Technical data	190
6.6.7	Dimension drawing	191
6.7	ANT D5	192
6.7.1	Features	192
6.7.2	Ordering data	192
6.7.3	Transmission window.....	193
6.7.4	Flush-mounted in metal	194
6.7.5	Minimum spacing	194
6.7.6	Technical data	195
6.7.7	Dimension drawing	197
6.8	ANT D6	198
6.8.1	Features	198
6.8.2	Ordering data	198
6.8.3	Transmission window.....	199
6.8.4	Metal-free area	200
6.8.5	Minimum spacing	200
6.8.6	Technical data	201
6.8.7	Dimensional diagram	202
6.9	ANT D10	203
6.9.1	Features	203
6.9.2	Ordering data	203
6.9.3	Transmission window.....	204
6.9.4	Metal-free area	205
6.9.5	Minimum spacing	206

6.9.6	Technical data.....	206
6.9.7	Dimensional diagram	208
7	Transponder	209
7.1	Memory configuration of ISO the transponders.....	209
7.2	MDS D100	210
7.2.1	Characteristics	210
7.2.2	Ordering data	210
7.2.3	Metal-free area.....	211
7.2.4	Technical data.....	212
7.2.5	Dimension drawing	214
7.3	MDS D117	215
7.3.1	Features	215
7.3.2	Ordering data	215
7.3.3	Mounting in metal.....	215
7.3.4	Technical specifications	216
7.3.5	Dimension drawing	217
7.4	MDS D124	218
7.4.1	Characteristics	218
7.4.2	Ordering data	218
7.4.3	Mounting on metal	219
7.4.4	Technical specifications	220
7.4.5	Use of the MDS D124 in hazardous area	221
7.4.6	Dimension drawing	223
7.5	MDS D126	224
7.5.1	Characteristics	224
7.5.2	Ordering data	224
7.5.3	Mounting on metal	225
7.5.4	Technical specifications	226
7.5.5	Dimension drawing	227
7.6	MDS D127	228
7.6.1	Features	228
7.6.2	Ordering data	228
7.6.3	Mounting in metal.....	229
7.6.4	Technical specifications	230
7.6.5	Dimension drawing	231
7.7	MDS D139	232
7.7.1	Characteristics	232
7.7.2	Ordering data	232
7.7.3	Metal-free area.....	233
7.7.4	Mounting in metal.....	234
7.7.5	Cleaning the transponder	234
7.7.6	Technical specifications	235
7.7.7	Use of the MDS D139 in hazardous areas	236
7.7.8	Dimension drawings.....	238
7.8	MDS D160	239
7.8.1	Characteristics	239
7.8.2	Ordering data	239
7.8.3	Mounting on metal	240

7.8.4	Technical specifications	240
7.8.5	Dimension drawings.....	242
7.9	MDS D165.....	243
7.9.1	Features	243
7.9.2	Ordering data	243
7.9.3	Technical data.....	244
7.9.4	Dimension drawing	245
7.10	MDS D200.....	246
7.10.1	Features	246
7.10.2	Ordering data	246
7.10.3	Mounting on metal	247
7.10.4	Technical data.....	248
7.10.5	Dimension drawing	250
7.11	MDS D261.....	250
7.11.1	Features	250
7.11.2	Ordering data	250
7.11.3	Technical data.....	251
7.11.4	Dimension drawing	252
7.12	MDS D324.....	253
7.12.1	Characteristics	253
7.12.2	Ordering data	253
7.12.3	Mounting on metal	254
7.12.4	Technical specifications	255
7.12.5	Dimension drawing	256
7.13	MDS D339.....	257
7.13.1	Characteristics	257
7.13.2	Ordering data	257
7.13.3	Mounting on metal	258
7.13.4	Mounting in metal.....	259
7.13.5	Cleaning the transponder.....	259
7.13.6	Technical specifications	260
7.13.7	Use of the MDS D339 in hazardous areas	261
7.13.8	Dimensional drawing.....	263
7.14	MDS D400.....	264
7.14.1	Features	264
7.14.2	Ordering data	264
7.14.3	Mounting on metal	265
7.14.4	Technical specifications	266
7.14.5	Dimension drawing	268
7.15	MDS D421.....	269
7.15.1	Characteristics	269
7.15.2	Ordering data	269
7.15.3	Mounting on metal	270
7.15.4	Technical specifications	272
7.15.5	Dimension drawing	273
7.16	MDS D422.....	274
7.16.1	Characteristics	274
7.16.2	Ordering data	274

7.16.3	Mounting in metal.....	274
7.16.4	Technical specifications	275
7.16.5	Dimension drawing	276
7.17	MDS D423	277
7.17.1	Characteristics	277
7.17.2	Ordering data	277
7.17.3	Mounting on metal	277
7.17.4	Technical specifications	279
7.17.5	Dimensional drawing.....	281
7.18	MDS D424	281
7.18.1	Characteristics	281
7.18.2	Ordering data	282
7.18.3	Mounting on metal	282
7.18.4	Technical specifications	283
7.18.5	Dimension drawing	285
7.19	MDS D425	285
7.19.1	Characteristics	285
7.19.2	Ordering data	286
7.19.3	Application example.....	286
7.19.4	Technical specifications	286
7.19.5	Dimension drawing	288
7.20	MDS D426	288
7.20.1	Characteristics	288
7.20.2	Mounting on metal	289
7.20.3	Ordering data	290
7.20.4	Technical specifications	290
7.20.5	Dimension drawing	291
7.21	MDS D428	292
7.21.1	Characteristics	292
7.21.2	Ordering data	292
7.21.3	Application example.....	293
7.21.4	Technical specifications	293
7.21.5	Dimension drawing	295
7.22	MDS D460	295
7.22.1	Characteristics	295
7.22.2	Ordering data	296
7.22.3	Mounting on metal	296
7.22.4	Technical specifications	297
7.22.5	Dimension drawings.....	298
7.23	MDS D521	299
7.23.1	Characteristics	299
7.23.2	Ordering data	299
7.23.3	Mounting on metal	299
7.23.4	Technical specifications	301
7.23.5	Dimension drawing	303
7.24	MDS D522	303
7.24.1	Characteristics	303
7.24.2	Ordering data	304

7.24.3	Mounting in metal.....	304
7.24.4	Technical specifications	305
7.24.5	Dimension drawing	306
7.25	MDS D522 special variant	307
7.25.1	Characteristics	307
7.25.2	Ordering data	307
7.25.3	Mounting in metal.....	308
7.25.4	Installation instructions.....	308
7.25.5	Technical specifications	310
7.25.6	Dimensional drawing.....	311
7.26	MDS D524.....	312
7.26.1	Characteristics	312
7.26.2	Ordering data	312
7.26.3	Mounting on metal	313
7.26.4	Technical specifications	314
7.26.5	Dimension drawing	315
7.27	MDS D526.....	316
7.27.1	Characteristics	316
7.27.2	Ordering data	316
7.27.3	Mounting on metal	317
7.27.4	Technical specifications	318
7.27.5	Dimension drawing	319
7.28	MDS D528.....	320
7.28.1	Characteristics	320
7.28.2	Ordering data	320
7.28.3	Application example.....	321
7.28.4	Technical specifications	321
7.28.5	Dimension drawing	323
8	System integration	325
9	System diagnostics	329
9.1	Error codes of the RF200 readers	329
9.2	Diagnostics functions - STEP 7	331
9.2.1	Reader diagnostics with "Reader Status" (SLG Status)	331
9.2.2	Transponder diagnostics with "Tag Status" (MDS Status)	333
A	Appendix	335
A.1	Certificates & approvals	335
A.2	Accessories.....	337
A.2.1	Antenna splitter	337
A.2.2	Antenna multiplexer SIMATIC RF260X	339
A.2.2.1	Characteristics	339
A.2.2.2	Ordering data	339
A.2.2.3	Description	340
A.2.2.4	Principle of operation	340
A.2.2.5	Connectors.....	341
A.2.2.6	Configuration.....	342
A.2.2.7	Parameterization	342
A.2.2.8	RF260X commands	344

A.2.2.9	Technical specifications	345
A.2.2.10	Dimensional drawing.....	346
A.2.3	Wide-range power supply unit for SIMATIC RF systems	347
A.2.3.1	Features	347
A.2.3.2	Scope of supply	348
A.2.3.3	Ordering data	348
A.2.3.4	Safety Information.....	348
A.2.3.5	Connecting.....	349
A.2.3.6	Technical specifications.....	350
A.2.3.7	Pin assignment of DC outputs and mains connection	352
A.2.3.8	Dimension drawing	353
A.2.3.9	Certificates and approvals	354
A.2.4	Transponder holders.....	355
A.3	Connecting cable	361
A.3.1	Reader RF2xxR (RS-422) with ASM 456 / RF160C / RF170C / RF180C / RF182C	361
A.3.2	Reader RF2xxR (RS-422) with ASM 475	363
A.3.3	Reader RF2xxR (RS-422) with RF120C.....	364
A.3.4	Reader RF240R/RF260R/RF290R (RS232) with PC.....	364
A.3.5	Reader RF290R.....	366
A.4	Ordering data	367
A.5	Service & Support.....	377
Index.....		379

Introduction

Introduction

SIMATIC RF200 is a compact RFID system in the SIMATIC RFID product family. The product range comprises cost-efficient RF readers that are ideal for use in small assembly lines or in intralogistics. SIMATIC RF200 RFID readers only support the RFID standard ISO 15693 and are therefore ideal for operation with the extensive range of ISO 15693 transponders.

The readers of the RF200 product family are available with the following interfaces:

- RS-422 for connecting to the communications modules
- RS-232 with a simple ASCII protocol for connection to PCs and third-party controllers
- IO-Link for connection to IO Link masters from Siemens and third-party controllers

Readers with an internal antenna have a particularly compact design (RF210R/RF220R/RF240R/RF260R). RF250R and RF290R are designed for operation with external antennas either to achieve longer distances or larger field sizes (RF290R with ANT D5/D6/D10) or to allow installation where there is very little space (RF250R with ANT 3/8/12/18/30).

Scope of validity of this document

This documentation is valid for all variants of the SIMATIC RF200 system and describes the devices shipped as of July 2015.

Registered trademarks

SIMATIC®, SIMATIC RF®, MOBY®, RF MANAGER® and SIMATIC Sensors® are registered trademarks of Siemens AG.

Further information

For additional information, refer to the manuals:

- Function manual "Ident profile and Ident blocks"
(<https://support.industry.siemens.com/cs/us/en/view/106368029>)
- Function manual "FB 45" (<https://support.industry.siemens.com/cs/ww/en/view/21738808>)
- Operating instructions "RF200 IO-Link"
(<https://support.industry.siemens.com/cs/ww/en/view/60641859>)
- System manual "MOBY D"
(<https://support.industry.siemens.com/cs/ww/en/view/13628689>)

- Operating instructions "RF310M"
(<https://support.industry.siemens.com/cs/us/en/view/51812642>)
- Product information "RF200 command set"
(<https://support.industry.siemens.com/cs/us/en/view/44864850>)

History

The following issues of the SIMATIC RF200 system manual have been published:

Output	Note
03/2011	First edition
05/2011	Expansion of the documentation with the addition of the device variant RF260R with RS-232 interface
09/2011	Expansion of the documentation with the device variant RF240R
03/2013	Expansion of the documentation with the device variant RF290R
09/2013	Expansion of the documentation by the following: <ul style="list-style-type: none"> • The device variant RF250R • The device variants RF240R and RF260R with ASCII interface • Antennas ANT 8, ANT 12, ANT 18 and ANT 30 • Transponder
07/2015	Expansion of the documentation by the following: <ul style="list-style-type: none"> • ANT 3 antennas • MDS D5xx transponder • Mobile reader RF210R
05/2017	Expansion of the documentation by the following: <ul style="list-style-type: none"> • Device version RF280R • Mobile Reader RF350M

1.1 Abbreviations and naming conventions

Abbreviations and naming conventions

The following terms/abbreviations are used synonymously in this document:

Reader	Write/read device (SLG)
Transponder, tag	Data carrier, mobile data storage, (MDS)
Communications module (CM)	Interface module (ASM)

Safety notes

SIMATIC RFID products comply with the salient safety specifications acc. to IEC, VDE, EN, UL and CSA. If you have questions about the permissibility of the installation in the planned environment, please contact your service representative.

 WARNING
<p>Opening the device</p> <p>Do not open the device when the power supply is on. Unauthorized opening of and improper repairs to the device may result in substantial damage to equipment or risk of personal injury to the user.</p>

NOTICE
<p>Alterations not permitted</p> <p>Alterations to the devices are not permitted.</p> <p>Failure to observe this requirement shall constitute a revocation of the radio equipment approval, CE approval and manufacturer's warranty.</p>

Installation instructions

NOTICE
<p>Switch/fuse to disconnect the reader from the power supply</p> <p>Make sure that the readers can be disconnected from the power supply with a switch or a fuse. The function of the switch or fuse must be clearly recognizable.</p>

Operating temperature

 CAUTION
<p>Danger of burns</p> <p>Note that some outer components of the reader are made of metal. Depending on the environmental conditions temperatures can occur on the device that are higher than the maximum permitted operating temperature.</p>

Repairs

 **WARNING**

Repairs only by authorized qualified personnel

Repairs may only be carried out by authorized qualified personnel. Unauthorized opening of and improper repairs to the device may result in substantial damage to equipment or risk of personal injury to the user.

System expansions

Only install system expansions intended for this system. If you install other expansions, you may damage the system or violate the safety requirements and regulations for radio frequency interference suppression. Contact Technical Support or your local sales department to find out which system expansions are suitable for installation.

NOTICE

Warranty conditions

If you cause system defects by installing or exchanging system expansion devices, the warranty becomes void.

Safety distances

 **CAUTION**

Safety distance between reader/antenna and persons

Note that for permanent exposure, the following safety distances must be adhered to:

- RF310R: ≥ 80 mm
- RF340R: ≥ 130 mm
- RF350R + ANT 1: ≥ 140 mm
- RF350R + ANT 3: ≥ 80 mm
- RF350R + ANT 12: ≥ 25 mm
- RF350R + ANT 18: ≥ 50 mm
- RF350R + ANT 30: ≥ 80 mm
- RF380R: ≥ 250 mm
- RF382R: ≥ 130 mm

Note

Safety distance with pacemakers

A safety distance between reader/antenna and persons with pacemakers is not necessary.

Security information

Siemens provides products and solutions with industrial security functions that support the secure operation of plants, systems, machines and networks.

In order to protect plants, systems, machines and networks against cyber threats, it is necessary to implement – and continuously maintain – a holistic, state-of-the-art industrial security concept. Siemens' products and solutions only form one element of such a concept.

Customer is responsible to prevent unauthorized access to its plants, systems, machines and networks. Systems, machines and components should only be connected to the enterprise network or the internet if and to the extent necessary and with appropriate security measures (e.g. use of firewalls and network segmentation) in place.

Additionally, Siemens' guidance on appropriate security measures should be taken into account. For more information about industrial security, please visit

Link: (<http://www.siemens.com/industrialsecurity>)

Siemens' products and solutions undergo continuous development to make them more secure. Siemens strongly recommends to apply product updates as soon as available and to always use the latest product versions. Use of product versions that are no longer supported, and failure to apply latest updates may increase customer's exposure to cyber threats.

To stay informed about product updates, subscribe to the Siemens Industrial Security RSS Feed under

Link: (<http://www.siemens.com/industrialsecurity>).

System overview

SIMATIC RF200 is an inductive identification system that is compatible with the ISO 15693 standard and was specially designed for use in industrial production for the control and optimization of material flows.

In contrast to SIMATIC RF300, SIMATIC RF200 is intended for RFID applications where performance requirements are not very high, for example with regard to data volume, transfer rate or diagnostics options. SIMATIC RF200 is characterized by particularly favorable prices.

3.1 RFID components and their function

RF200 system components

Figure 3-1 RF200 system overview

Table 3- 1 Reader-transponder combination options, Part 1

Transponder	RF210R/ RF210M	RF220R	RF240R	RF260R	RF280R	RF290R ⁴⁾	RF350M
MDS D100	--	○	✓	✓	✓	✓	✓
MDS D117	○	--	--	--	--	--	✓ ⁶⁾
MDS D124	✓	✓	✓	✓	✓	✓	✓
MDS D126	--	✓	✓	✓	✓	✓	✓
MDS D127	✓	--	--	--	--	--	✓ ⁶⁾
MDS D139 ¹⁾	--	○	○	✓	✓	✓	✓
MDS D160 ²⁾	✓	✓	✓	✓	✓	✓	✓
MDS D165	--	○	✓	✓	✓	✓	✓
MDS D200	--	○	✓	✓	✓	✓	✓
MDS D261	--	○	✓	✓	✓	✓	✓
MDS D324	✓	✓	✓	✓	✓	✓	✓
MDS D339	--	○	○	✓	✓	✓	✓
MDS D400	--	--	✓	✓	✓	✓	✓
MDS D421	✓	○	--	--	--	--	✓ ⁶⁾
MDS D422	✓	✓	✓	--	--	--	✓ ⁶⁾
MDS D423	✓	✓	✓	✓	✓	--	✓
MDS D424	✓	✓	✓	✓	✓	✓	✓
MDS D425	✓	✓	✓	--	✓	--	✓
MDS D426	--	✓	✓	✓	✓	✓	✓
MDS D428	✓	✓	✓	✓	✓	--	✓
MDS D460	✓	✓	✓	✓	✓	○ / ✓ ⁵⁾	✓
MDS D521	✓	○	--	--	--	--	✓ ⁶⁾
MDS D522 ³⁾	✓	✓	✓	--	--	--	✓ ⁶⁾
MDS D524	✓	✓	✓	✓	✓	✓	✓
MDS D525	✓	✓	✓	--	✓	--	--
MDS D526	--	✓	✓	✓	✓	✓	✓
MDS D528	✓	✓	✓	✓	✓	--	✓

1) only with the article number 6GT2600-0AA10

2) only with the article number 6GT2600-0AB10

3) The transponder MDS D522 special variant has the same compatibility as the transponder MDS D522.

4) in conjunction with ANT D5, D6 or D10

5) combination recommended only in conjunction with ANT D5.

6) Only in conjunction with RF350M for external antennas (6GT2803-1BA10)

- ✓ Combination possible
- Combination not possible
- Combination possible, but not recommended

3.1 RFID components and their function

Table 3-2 Reader-transponder combination options, Part 2

RF250R with						
Transponder	ANT 1	ANT 3	ANT 8	ANT 12	ANT 18	ANT 30
MDS D100	✓	○	--	--	--	○
MDS D117	--	--	✓	✓	--	--
MDS D124	✓	✓	--	--	✓	✓
MDS D126	✓	✓	--	--	--	✓
MDS D127	--	--	✓	✓	--	--
MDS D139	✓	○	--	--	--	○
MDS D160	✓	✓	--	✓	✓	✓
MDS D165	✓	○	--	--	--	○
MDS D200	✓	○	--	--	--	○
MDS D261	✓	○	--	--	--	○
MDS D324	✓	✓	--	○	✓	✓
MDS D339	✓	○	--	--	--	○
MDS D400	✓	○	--	--	--	○
MDS D421	--	--	✓	✓	✓	--
MDS D422	--	✓	--	✓	✓	✓
MDS D423	✓	✓	--	--	✓	✓
MDS D424	✓	✓	--	--	✓	✓
MDS D425	✓	✓	--	✓	✓	✓
MDS D426	✓	✓	--	--	--	✓
MDS D428	✓	✓	--	✓	✓	✓
MDS D460	✓	✓	--	✓	✓	✓
MDS D521	--	--	✓	✓	✓	--
MDS D522)	--	✓	--	✓	✓	✓
MDS D524	✓	✓	--	--	✓	✓
MDS D525	✓	✓	--	✓	✓	✓
MDS D526	✓	✓	--	--	--	✓
MDS D528	✓	✓	--	✓	✓	✓

- ✓ Combination possible
- Combination not possible
- Combination possible, but not recommended

3.2 Overview of transponders

Overview of typical areas of application of ISO transponders for RF200

Transponder	Area of application
MDS D100	From simple identification such as electronic barcode replacement or supplementation, through warehouse and distribution logistics, right up to product identification. With this transponder, the maximum ranges are achieved in combination with the SIMATIC RF260R reader.
MDS D117	Very compact data carrier that can be cemented into objects where precise positioning is necessary. e.g. tool identification.
MDS D124	Application areas in factory automation (e.g. small paintshops to 180°C).
MDS D126	Compact and rugged ISO transponder; suitable for identification of transport units in production-related logistics; can also be deployed in harsh conditions.
MDS D127	Very compact data carrier that can be screwed into areas where precise positioning is necessary. e.g. tool identification.
MDS D139 ¹⁾	Applications in production automation with high temperature demands (up to +220 °C). Typical application areas: <ul style="list-style-type: none"> • Paintshops and their preparatory treatments • Primer coat, electrolytic dip area, cataphoresis with the associated drying furnaces • Top coat area with drying furnaces • Washing areas at temperatures > 85 °C • Other applications with higher temperatures
MDS D160 ²⁾	Typical applications are, for example: <ul style="list-style-type: none"> • Rented work clothing • Hotel laundry • Surgical textiles • Hospital clothing • Dirt collection mats • Clothing for nursing homes/hostels • Assembly lines with very small workpiece holders
MDS D165	Smart label (self-adhesive label) From simple identification such as electronic barcode replacement/supplementation, through warehouse and distribution logistics, right up to product identification
MDS D200	From simple identification such as electronic barcode replacement/supplementation, through warehouse and distribution logistics, right up to product identification.
MDS D261	Smart label (self-adhesive label) The design of the transponder (self-adhesive label) permits a variety of designs in order to ensure optimum dimensioning for the widest variety of applications. From simple identification such as electronic barcode replacement/supplementation, through warehouse and distribution logistics, right up to product identification.
MDS D324	Production and distribution logistics as well as in assembly and production lines
MDS D339	Applications in production automation with high temperature demands (up to +220 °C). For typical areas of application, see "MDS D139".

3.2 Overview of transponders

Transponder	Area of application
MDS D400	Simple identification such as electronic barcode replacement/supplements, from warehouse and distribution logistics right through to product identification.
MDS D421	The MDS D421 is designed for tool coding according to DIN 69873. It can be used wherever small data carriers and exact positioning are required, e.g. tool identification, workpiece holders
MDS D422	Identification of metallic workpiece holders, workpieces or containers
MDS D423	Identification of metallic workpiece holders, workpieces or containers, production automation
MDS D424	Production and distribution logistics as well as in assembly and production lines
MDS D425	Compact and rugged ISO transponder; suitable for screw mounting. Use in assembly and production lines in the powertrain sector; ideal for mounting on motors, gearboxes, and workpiece holders
MDS D426	Compact and rugged ISO transponder; suitable for identification of transport units in production-related logistics; can also be deployed in harsh conditions
MDS D428	Compact and rugged ISO transponder; suitable for screw mounting Use in assembly and production lines in the powertrain sector
MDS D460	Assembly lines with very small workpiece holders
MDS D521	The MDS D521 is constructed for tool coding according to DIN 69873. It can be used wherever small data carriers and exact positioning are required, e.g. tool identification, workpiece holders.
MDS D522	Identification of metallic workpiece holders, workpieces or containers
MDS D522 Special variants	If Identification of metallic workpiece holders or workpieces
MDS D524	Production and distribution logistics as well as in assembly and production lines
MDS D526	Compact and rugged ISO transponder; suitable for identification of transport units in production-related logistics; can also be deployed in harsh environmental conditions
MDS D528	Compact and rugged ISO transponder; suitable for screw mounting Use in assembly and production lines in the powertrain sector

- 1) Only with the MLFB 6GT2600-0AA10
- 2) Only with the MLFB 6GT2600-0AB10

Overview of the memory sizes of the ISO transponders for RF200

Transponder	Memory size
MDS D1xx	112 bytes of EEPROM
MDS D2xx	256 bytes of EEPROM
MDS D3xx	992 bytes of EEPROM
MDS D4xx	2000 bytes FRAM
MDS D5xx	8192 bytes FRAM

Planning the RF200 system

4.1 Fundamentals of application planning

4.1.1 Selection criteria for SIMATIC RF200 components

Assess your application according to the following criteria, in order to choose the right SIMATIC RF200 components:

- Static or dynamic data transfer
- Data volume to be transferred
- Speed in case of dynamic transfer
- Ambient conditions such as relative humidity, temperature, chemical impacts, etc.

4.1.2 Transmission window and read/write distance

The reader generates an inductive alternating field. The field is strongest close to the reader; however, a read/write distance of "zero" between reader and transponder is not recommended.

The field strength of the alternating field decreases quickly in proportion to the distance from the reader. The distribution of the field depends on the structure and geometry of the antennas in the reader and transponder

A prerequisite for the function of the transponder is a minimum field strength at the transponder, which is still barely achieved at distance S_g from the reader.

The picture below shows the transmission window of the SIMATIC RF210R and SIMATIC RF220R readers between transponder and reader:

View from the side

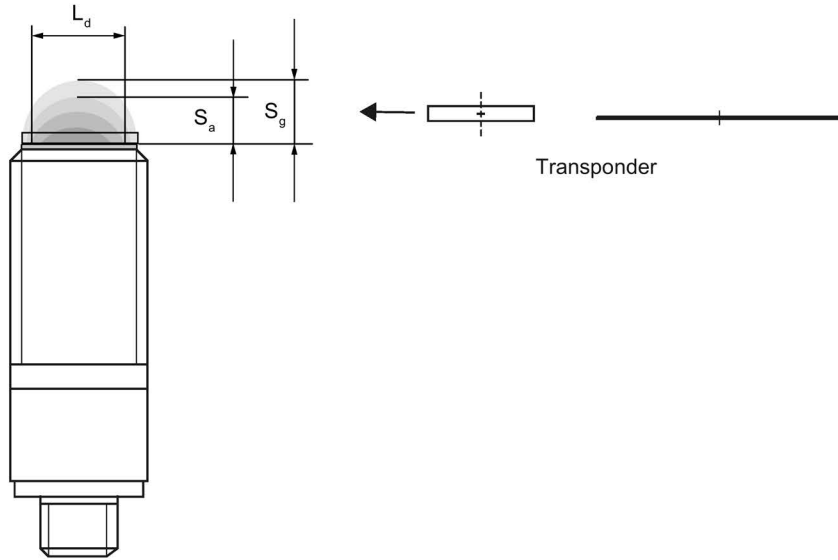

View from above

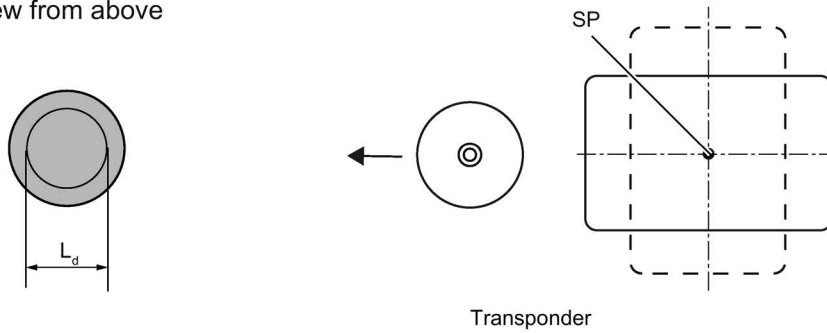

Transmission window

- S_a Operating distance between transponder and reader
- S_g Limit distance (maximum clear distance between upper surface of the reader and the transponder, at which the transmission can still function under normal conditions)
- L Diameter of a transmission window
- SP Intersection of the axes of symmetry of the transponder

Figure 4-1 RF210R/RF220R transmission window

The figure below shows the transmission window of the SIMATIC RF240R and SIMATIC RF260R readers between transponder and reader:

Front view

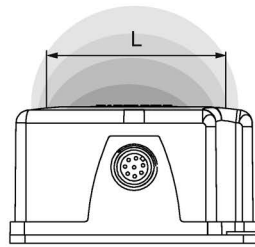

Side view

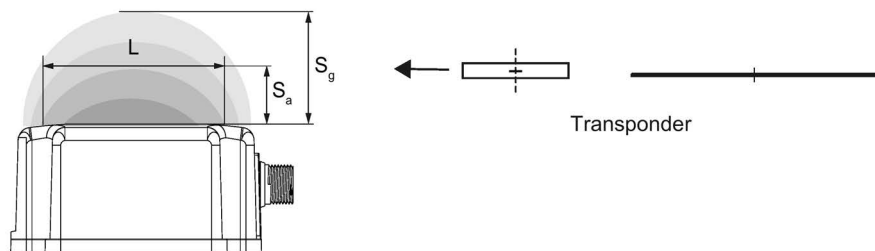

Top view

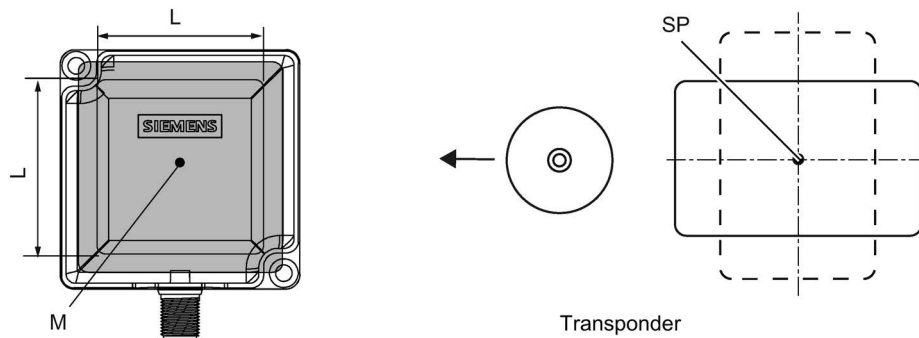

- S_a Operating distance between transponder and reader
- S_g Limit distance (maximum clear distance between upper surface of the reader and the transponder, at which the transmission can still function under normal conditions)
- L Length of a transmission window
- M Field centerpoint

Figure 4-2 RF240R/RF260R transmission window

The transponder can be used as soon as the intersection (SP) of the transponder enters the area of the transmission window.

From the diagrams above, it can also be seen that operation is possible within the area between S_a and S_g . The active operating area reduces as the distance increases, and shrinks to a single point at distance S_g . Only static mode should thus be used in the area between S_a and S_g .

4.1.3 Width of the transmission window

Determining the width of the transmission window

The following approximation formula can be used for practical applications:

$$B = 0.4 \cdot L$$

B: Width of the transmission window

L: Length of the transmission window

Tracking tolerances

The width of the transmission window (B) is particularly important for the mechanical tracking tolerance. The formula for the dwell time is valid without restriction when B is observed.

4.1.4 Impact of secondary fields

Secondary fields in the range from 0 mm to 30% of the limit distance (S_g) generally always exist.

They should, however, only be used during configuration in exceptional cases, since the read/write distances are very limited. Exact details of the secondary field geometry cannot be given, since these values depend heavily on the operating distance and the application. When working in dynamic mode, remember that during the transition from the secondary field to the main field the presence of the tag is lost temporarily. It is therefore advisable to select a distance $> 30\%$ of S_g .

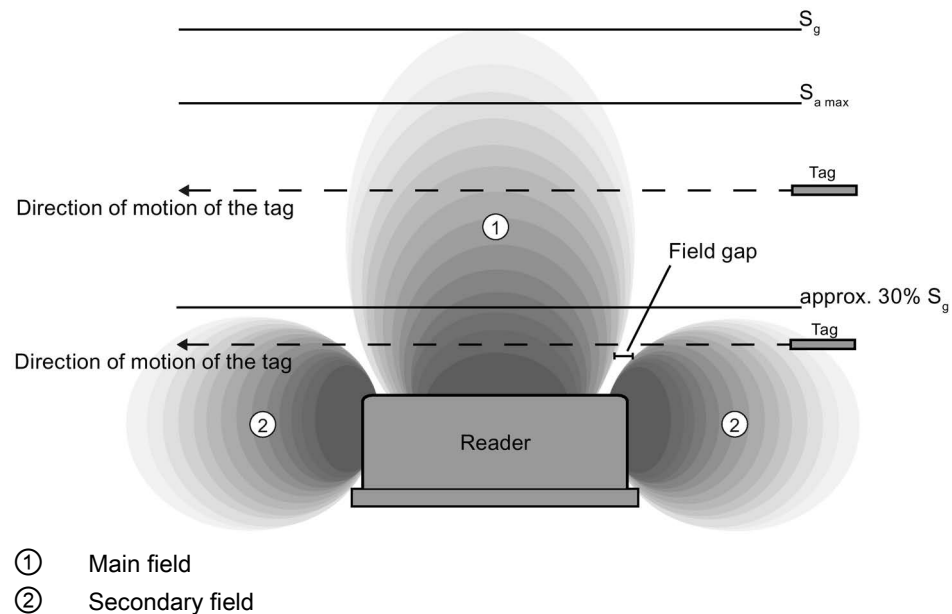
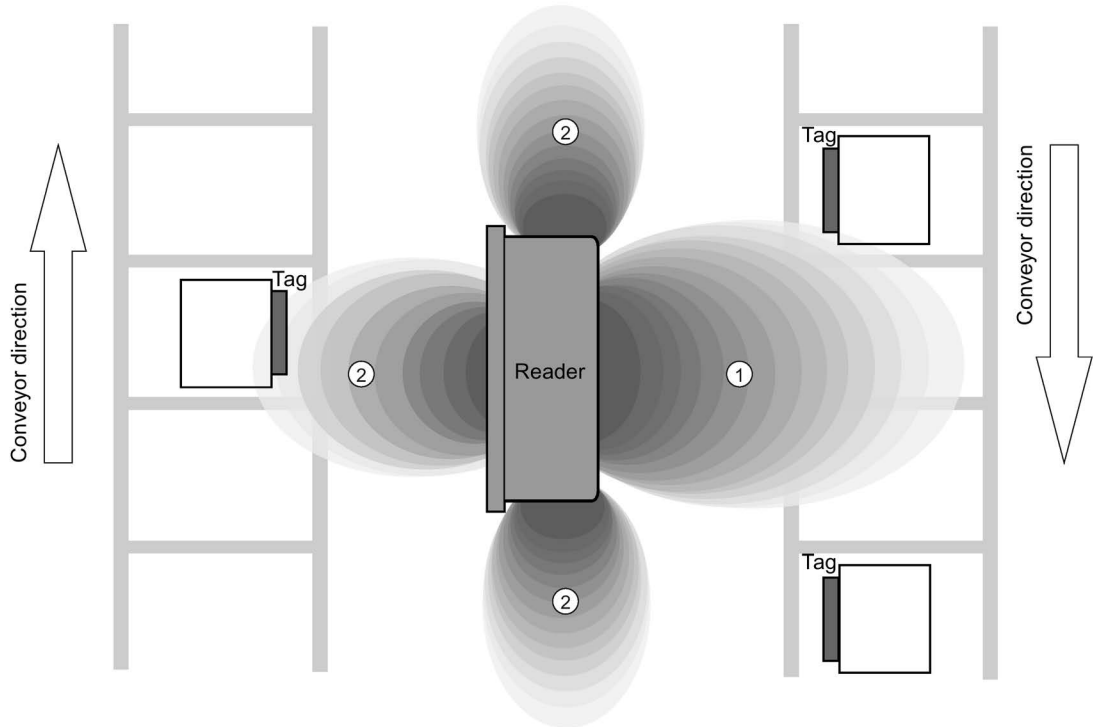

Figure 4-3 Gap in the field resulting from secondary fields

Secondary fields without shielding

The following graphic shows typical primary and secondary fields, if no shielding measures are taken.



- ① Main field
- ② Secondary field

Figure 4-4 Secondary field without shielding

In this arrangement, the reader can also read tags via the secondary field. Shielding is required in order to prevent unwanted reading via the secondary field, as shown and described in the following.

Secondary fields with shielding

The following graphic shows typical primary and secondary fields, with metal shielding this time.

The metal shielding prevents the reader from detecting tags via the secondary field.

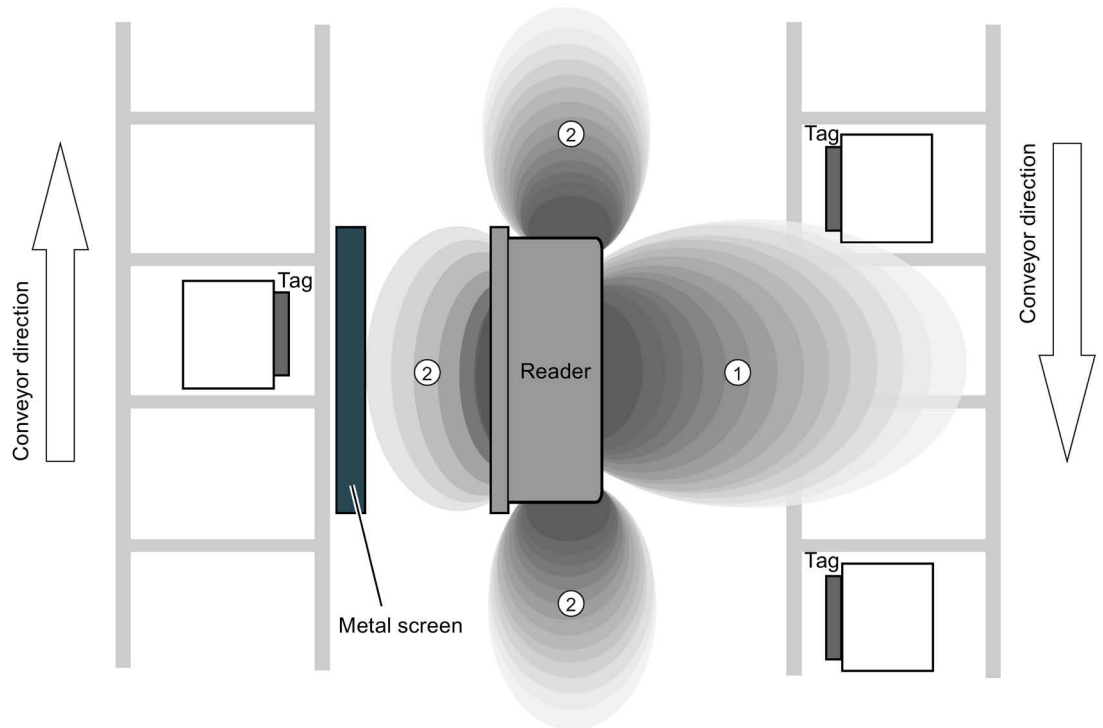

- ① Main field
- ② Secondary field

Figure 4-5 Secondary field with shielding

4.1.5 Permissible directions of motion of the transponder

Detection area and direction of motion of the transponder

The transponder and reader have no polarization axis, i.e. the transponder can come in from any direction, assume any position as parallel as possible to the reader, and cross the transmission window. The figure below shows the active area for various directions of transponder motion:

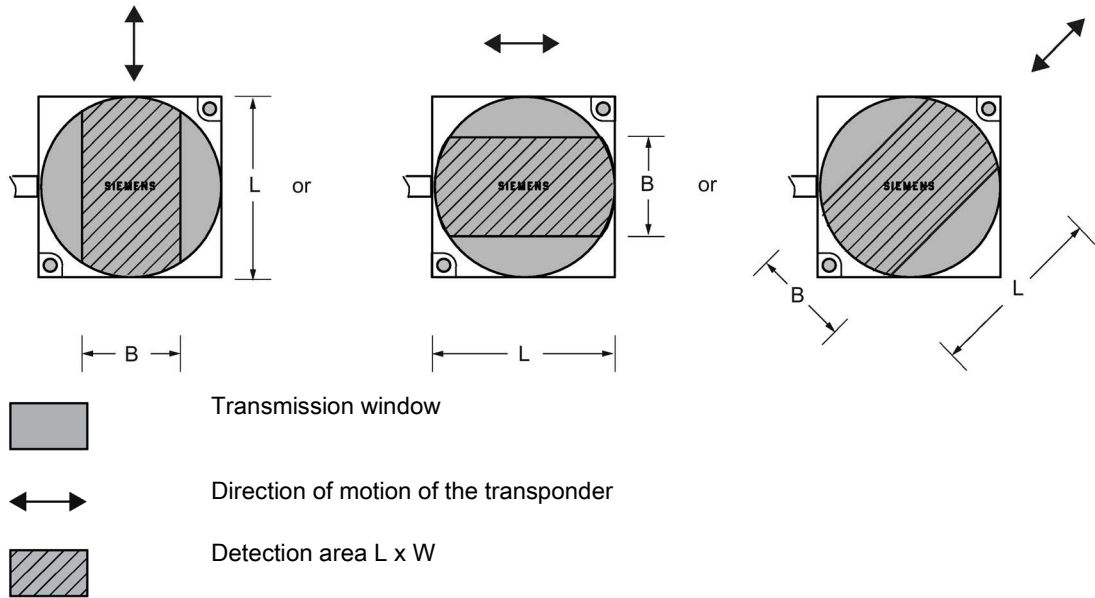

Figure 4-6 Detection areas of the reader for different directions of transponder motion

4.1.6 Operation in static and dynamic mode

Operation in static mode

If working in static mode, the transponder can be operated up to the limit distance (S_g). The transponder must then be positioned exactly over the reader:

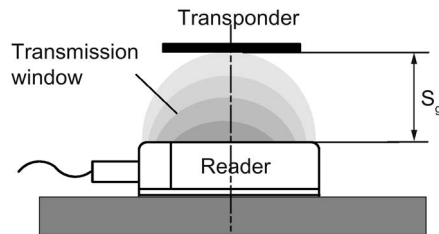

Figure 4-7 Operation in static mode

Note

Note that in a metallic environment the values for the limit distance are reduced.

Operation in dynamic mode

When working in dynamic mode, the transponder moves past the reader. The transponder can be used as soon as the intersection (SP) of the transponder enters the circle of the transmission window. In dynamic mode, the operating distance (S_a) is of primary importance. [Operating distances, see Chapter Field data of transponders and readers (Page 38)]

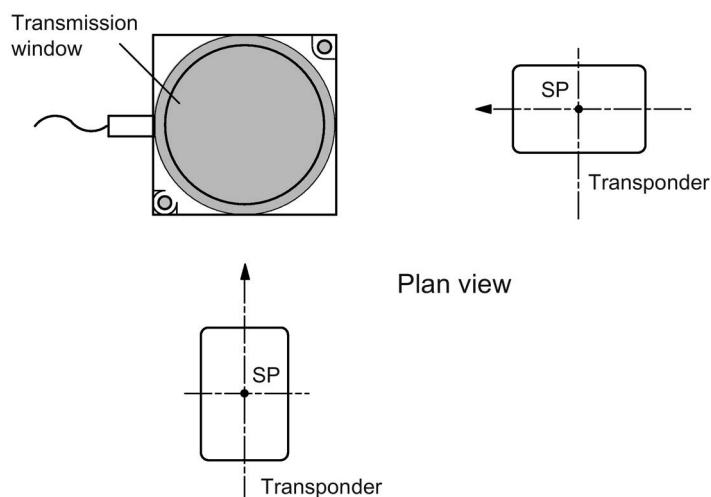

Figure 4-8 Operation in dynamic mode

4.1.7 Dwell time of the transponder

The dwell time is the time in which the transponder remains within the transmission window of the reader. The reader can exchange data with the transponder during this time.

The dwell time is calculated as follows:

$$t_v = (L * 0,8 [m]) : V_{Tag} [m/s]$$

- tv: Dwell time of the transponder
- L: Length of the transmission window
- v_{Tag}: Speed of the transponder (tag) in dynamic mode
- 0.8: Constant factor used to compensate for temperature influence and production tolerances

The dwell time can be of any duration in static mode. The dwell time must be sufficiently long to allow communication with the transponder.

The dwell time is defined by the system environment in dynamic mode. The volume of data to be transferred must be matched to the dwell time or vice versa. As a general rule:

$$t_v \geq t_k$$

- tv: Dwell time of the data memory in the field of the reader
- tk: Communication time between transponder and communication module

$$t_k = K + t_{Byte} * n$$

or Calculation of the maximum amount of user data

$$n_{max} = (t_v - K) : t_{Byte}$$

- tk: Communication time between transponder and communication module
- K Constant; the constant is an internal system time. This includes the time for power buildup on the MDS and for command transfer
- t_{Byte} Transmission time for 1 byte
- n Amount of user data in bytes
- n_{max} Maximum amount of user data in bytes in dynamic mode
- tv Dwell time of the data memory in the field of the reader

4.1.8 Communication between communication module, reader and transponder

Aids for calculating the data transmission times

User-friendly calculation tools are available for the communications modules ASM 456, RF160C, RF170C and RF180C to calculate data transfer times. The calculation tools can be found on the DVD "Ident Systems Software & Documentation", article number 6GT2080-2AA20.

ASM 456 Command Processing Time Calculation V2.2 - 01/2010

Parameter Input

CPU DP-Master

Cycle Time: 5 ms

counter_customer: 2

Transfer Time: 3 ms

Acyc for DP-cycle: 2

Acyc parallel: 4

Supply level: 40 %

Command Parameter:

Data length: 1000 Byte

Number of working readers: 1

Other PROFIBUS Slaves

Slave number: 0

Sum I/O: 0

PROFIBUS

Baud rate: 1.5 Mbaud

Profibus Cycle Time: 0.5 ms

ASM 456

Number: 1

Baudrate SLG: 115.2 kBaud

SLG / READER

HF transfer

t Byte: 0.13 ms/Byte

K: 8.5 ms

MDS / TAG

Calculation RESULTS

Processing Time (Estimation)	231 ms
Processing Time HF Field (dynamic mode)	173 ms

Figure 4-9 User interface of the calculation tool for command processing time

Aids for calculating the field data

You will also find a tool for calculating field data on the DVD "Ident Systems, Software & Documentation". Using this tool, among other things you can calculate the operating distance (S_a), limit distance (S_g) and transmission window (L).

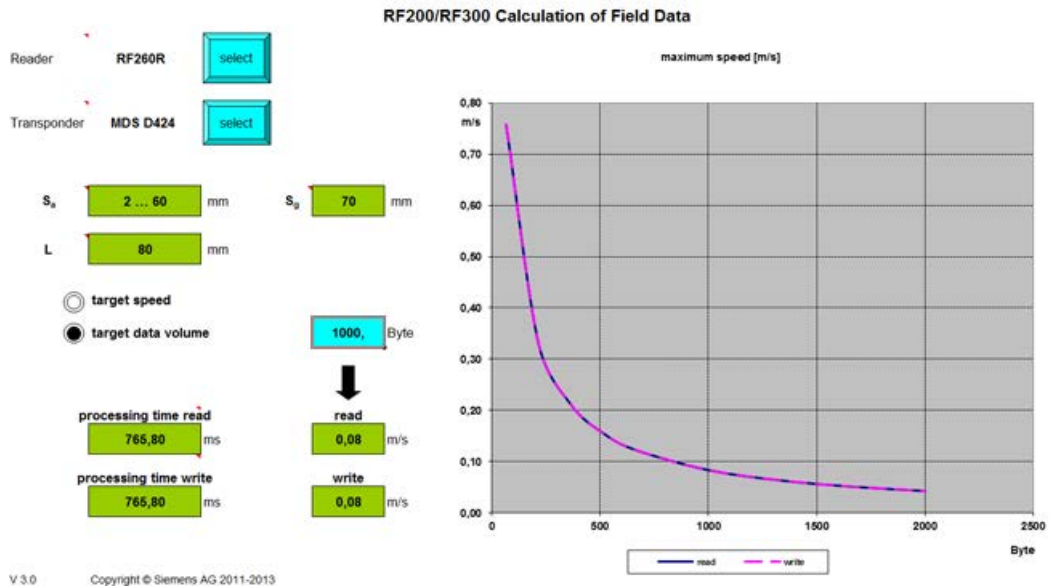

Figure 4-10 User interface of the calculation tool for field data acquisition

4.2 Field data of transponders and readers

The following tables show the field data for all SIMATIC RF200 components of transponders and readers. This makes the correct selection of a transponder and reader particularly easy.

All the technical specifications listed are typical data and are applicable for an ambient temperature between 0 °C and +50 °C, a supply voltage between 22 and 27 VDC and a metal-free environment. **Tolerances of ±20 % are permitted due to production or temperature conditions.**

If the entire voltage range at the reader of 20 VDC to 30 VDC and/or the entire temperature range of transponders and readers is used, the field data is subject to further tolerances.

Note

Transmission gaps

If the minimum operating distance (S_a) is not observed, a transmission gap can occur in the center of the field. Communication with the transponder is not possible in the transmission gap.

Note

Possible reader-transponder combinations

The tables of the following section show the possible reader-transponder combinations.

4.2.1 Field data

The limit distances (S_g) and operating distances (S_a) along with the length of the transmission window for each reader-transponder combination are listed in the tables below.

Table 4- 1 SIMATIC RF210R field data

	Length of the transmission window (L_d)	Operating distance (S_a)	Limit distance (S_g)
MDS D124	25	1 ... 18	20
MDS D127 ¹⁾	3	0 ... 2	2
MDS D160	20	1 ... 10	12
MDS D324	20	1 ... 8	9
MDS D421	5	0 ... 3	4
MDS D422	8	1 ... 9	10
MDS D423	20	2 ... 10	12
MDS D424	24	1 ... 16	18
MDS D425	12	1 ... 6	7
MDS D428	20	1 ... 10	11
MDS D460	8	1 ... 8	9
MDS D521	5	0 ... 3	4
MDS D522	8	1 ... 8	9
MDS D522 Special variants	8	1 ... 8	9
MDS D524	20	1 ... 15	17
MDS D525	12	1 ... 6	7
MDS D528	15	1 ... 10	11

¹⁾ The transponder is only suitable for static mode.

All dimensions in mm.

Table 4- 2 SIMATIC RF220R field data

	Length of the transmission window (L _d)	Operating distance (S _a)	Limit distance (S _g)
MDS D124	35	1 ... 28	31
MDS D126	45	2 ... 30	35
MDS D160	20	1 ... 20	22
MDS D324	30	2 ... 21	25
MDS D422	18	1 ... 12	14
MDS D423	30	2 ... 24	28
MDS D424	30	2 ... 25	29
MDS D425	20	1 ... 11	13
MDS D426	40	2 ... 25	30
MDS D428	25	1 ... 18	21
MDS D460	25	1 ... 18	20
MDS D522	15	1 ... 10	12
MDS D522 Special variants	15	1 ... 10	12
MDS D524	25	2 ... 22	25
MDS D525	20	1 ... 11	13
MDS D526	30	2 ... 25	30
MDS D528	20	1 ... 15	20

All dimensions in mm.

Table 4- 3 SIMATIC RF240R field data

	Length of the transmission window (L)	Operating distance (S _a)	Limit distance (S _g)
MDS D100	100	2 ... 84	95
MDS D124	65	2 ... 53	60
MDS D126	80	2 ... 57	65
MDS D160	50	1 ... 33	37
MDS D165	105	2 ... 80	94
MDS D200	90	2 ... 69	78
MDS D261	70	2 ... 60	70
MDS D324	55	1 ... 36	40
MDS D400	95	2 ... 80	90
MDS D422	25	1 ... 12	15
MDS D423	45	2 ... 35	40
MDS D424	75	1 ... 47	53
MDS D425	30	1 ... 15	17
MDS D426	65	2 ... 45	55
MDS D428	50	1 ... 30	34
MDS D460	50	1 ... 30	34

	Length of the transmission window (L)	Operating distance (S _a)	Limit distance (S _g)
MDS D522	20	1 ... 10	12
MDS D522 Special variants	20	1 ... 10	12
MDS D524	60	1 ... 45	55
MDS D525	30	1 ... 15	17
MDS D526	60	2 ... 45	55
MDS D528	40	1 ... 30	35

All dimensions in mm.

Table 4- 4 Field data SIMATIC RF250R, with ANT 1

	Length of the transmission window (L _d)	Operating distance (S _a)	Limit distance (S _g)
MDS D100	80	5 ... 95	115
MDS D124	55	2 ... 60	75
MDS D126	150	2 ... 80	95
MDS D139	75	5 ... 90	105
MDS D160	50	2 ... 35	45
MDS D165	140	5 ... 95	110
MDS D200	130	5 ... 90	100
MDS D261	100	2 ... 90	110
MDS D324	50	5 ... 60	70
MDS D339	110	2 ... 85	100
MDS D400	140	10 ... 95	110
MDS D423	50	2 ... 35	45
MDS D424	40	2 ... 70	80
MDS D425	40	2 ... 25	30
MDS D426	110	2 ... 80	95
MDS D428	40	2 ... 40	50
MDS D460	50	2 ... 30	40
MDS D524	50	2 ... 65	80
MDS D525	40	2 ... 25	30
MDS D526	110	2 ... 80	95
MDS D528	40	2 ... 40	45

All dimensions in mm.

Table 4- 5 Field data SIMATIC RF250R, with ANT 3

	Length of the transmission window (L _d)	Operating distance (S _a)	Limit distance (S _g)
MDS D124	40	1 ... 32	40
MDS D126	65	0 ... 47	60
MDS D160	24	1 ... 23	30
MDS D324	32	1 ... 22	35
MDS D422	20	0 ... 12	15
MDS D423	30	2 ... 18	26
MDS D424	37	0 ... 34	48
MDS D425	22	1 ... 12	20
MDS D426	65	0 ... 44	58
MDS D428	30	1 ... 20	32
MDS D460	24	1 ... 21	27
MDS D522	20	1 ... 12	15
MDS D522 Special variants	20	1 ... 12	15
MDS D524	35	1 ... 35	40
MDS D525	22	1 ... 12	20
MDS D526	45	2 ... 35	45
MDS D528	25	1 ... 20	25

All dimensions in mm.

Table 4- 6 Field data SIMATIC RF250R, with ANT 8

	Length of the transmission window (L _d)	Operating distance (S _a)	Limit distance (S _g)
MDS D117	2	0 ... 2	3
MDS D127	3	0 ... 3	4
MDS D421	3	0 ... 3	4
MDS D521	3	0 ... 3	4

All dimensions in mm.

Table 4- 7 Field data SIMATIC RF250R, with ANT 12

	Length of the transmission window (L_d)	Operating distance (S_a)	Limit distance (S_g)
MDS D117	3	0 ... 3	4
MDS D127	4	0 ... 4	5
MDS D160	18	0 ... 12	17
MDS D421	10	0 ... 3	4
MDS D422	22	0 ... 7	10
MDS D425	12	0 ... 8	10
MDS D428	18	1 ... 8	12
MDS D460	16	1 ... 10	14
MDS D521	5	0 ... 3	4
MDS D522	10	1 ... 7	9
MDS D522 Special variants	10	1 ... 7	9
MDS D525	12	1 ... 8	10
MDS D528	15	1 ... 8	12

All dimensions in mm.

Table 4- 8 Field data SIMATIC RF250R, with ANT 18

	Length of the transmission window (L_d)	Operating distance (S_a)	Limit distance (S_g)
MDS D124	26	0 ... 24	37
MDS D160	22	1 ... 18	26
MDS D324	30	1 ... 18	27
MDS D421	16	0 ... 3	4
MDS D422	24	1 ... 8	14
MDS D423	21	1 ... 15	18
MDS D424	26	1 ... 27	36
MDS D425	19	1 ... 11	16
MDS D428	19	1 ... 18	25
MDS D460	19	1 ... 17	21
MDS D521	6	0 ... 4	5
MDS D522	15	1 ... 10	12
MDS D522 Special variants	15	1 ... 10	12
MDS D524	30	1 ... 25	30
MDS D525	19	1 ... 11	16
MDS D528	20	1 ... 15	20

All dimensions in mm.

Table 4- 9 Field data SIMATIC RF250R, with ANT 30

	Length of the transmission window (L _d)	Operating distance (S _a)	Limit distance (S _g)
MDS D124	40	1 ... 35	48
MDS D126	65	0 ... 47	60
MDS D160	24	1 ... 23	30
MDS D324	32	1 ... 22	35
MDS D422	27	0 ... 12	15
MDS D423	30	2 ... 18	26
MDS D424	37	0 ... 34	48
MDS D425	22	1 ... 12	20
MDS D426	65	0 ... 44	58
MDS D428	30	1 ... 20	32
MDS D460	24	1 ... 21	27
MDS D522	20	1 ... 12	15
MDS D522 Special variants	20	1 ... 12	15
MDS D524	35	1 ... 35	40
MDS D525	22	1 ... 12	20
MDS D526	60	2 ... 35	45
MDS D528	25	1 ... 20	25

All dimensions in mm.

Table 4- 10 SIMATIC RF260R field data

	Length of the transmission window (L)	Operating distance (S _a)	Limit distance (S _g)
MDS D100	120	2 ... 110	130
MDS D124	80	2 ... 80	85
MDS D126	110	2 ... 75	100
MDS D139	120	2 ... 80	110
MDS D160	60	2 ... 40	45
MDS D165	120	2 ... 120	135
MDS D200	120	2 ... 100	120
MDS D261	80	2 ... 75	90
MDS D324	80	2 ... 60	70
MDS D339	110	5 ... 65	80
MDS D400	140	2 ... 110	140
MDS D423	55	2 ... 40	45
MDS D424	80	2 ... 60	70
MDS D426	75	2 ... 70	85
MDS D428	50	2 ... 40	45
MDS D460	50	2 ... 40	45

	Length of the transmission window (L)	Operating distance (S _a)	Limit distance (S _g)
MDS D524	70	2 ... 60	70
MDS D526	80	2 ... 70	85
MDS D528	50	2 ... 35	40

All dimensions in mm.

Table 4- 11 Field data SIMATIC RF280R

	Length of the transmission window (L)		Operating distance (S _a)	Limit distance (S _g)
	in the x direction (L _x)	in the y direction (L _y)		
MDS D100 ¹⁾	140	100	10 ... 160	200
MDS D124	80	80	2 ... 110	130
MDS D126	180	140	2 ... 135	160
MDS D139	140	90	5 ... 115	190
MDS D160	80	40	2 ... 55	70
MDS D165 ¹⁾	200	140	10 ... 160	190
MDS D200 ²⁾	200	160	20 ... 140	185
MDS D261 ³⁾	190	120	20 ... 110	150
MDS D324	100	60	2 ... 85	110
MDS D339	290	140	5 ... 115	170
MDS D400	240	120	10 ... 170	200
MDS D423	110	60	5 ... 60	70
MDS D424	100	70	2 ... 100	140
MDS D425	80	45	2 ... 30	40
MDS D426	220	160	2 ... 145	175
MDS D428	80	50	2 ... 60	88
MDS D460	80	70	2 ... 55	70
MDS D524	100	70	2 ... 110	130
MDS D525	80	45	2 ... 30	40
MDS D526	220	160	2 ... 135	165
MDS D528	80	50	2 ... 60	85

All dimensions in mm.

- 1) Be aware that the minimum distance must be increased 10 mm starting at 40 °C ambient temperature.
- 2) Be aware that the minimum distance of the reader to the transponder must be increased approximately 6 mm every 5 °C starting at an ambient temperature of 25 °C and approximately 15 mm starting at an ambient temperature of 50 °C.
- 3) Be aware that the minimum distance of the reader to the transponder must be increased approximately 3 mm every 5 °C starting at an ambient temperature of 25 °C and approximately 14 mm starting at an ambient temperature of 50 °C.

4.2 Field data of transponders and readers

Table 4- 12 Field data SIMATIC RF290R, with ANT D5 (at 4 W)

	Length of the transmission window (L)	Operating distance (S _a)	Limit distance (S _g)
MDS D100	320	0 ... 400	500
MDS D124	300	0 ... 200	280
MDS D126	320	0 ... 350	400
MDS D139	320	0 ... 400	500
MDS D160	300	0 ... 130	180
MDS D165	320	0 ... 350	450
MDS D200	320	0 ... 400	500
MDS D261	320	0 ... 300	400
MDS D324	300	0 ... 200	280
MDS D339	320	0 ... 300	380
MDS D400	320	0 ... 400	500
MDS D424	300	0 ... 200	280
MDS D426	320	0 ... 300	350
MDS D460	300	0 ... 120	160
MDS D524	300	0 ... 200	280
MDS D526	320	0 ... 300	350

All dimensions in mm.

Table 4- 13 Field data SIMATIC RF290R, with ANT D6 (at 4 W)

	Length of the transmission window (L)		Operating distance (S _a)	Limit distance (S _g)
	X direction	Y direction		
MDS D100	520	420	0 ... 550	650
MDS D124	500	400	0 ... 220	300
MDS D126	520	420	0 ... 400	500
MDS D139	520	420	0 ... 500	600
MDS D160	500	400	0 ... 130	180
MDS D165	520	420	0 ... 400	500
MDS D200	520	420	0 ... 500	600
MDS D261	520	420	0 ... 350	450
MDS D324	500	400	0 ... 200	280
MDS D339	520	420	0 ... 400	480
MDS D400	520	420	0 ... 500	650
MDS D424	500	400	0 ... 220	300
MDS D426	520	420	0 ... 350	400
MDS D524	500	400	0 ... 220	300
MDS D526	520	420	0 ... 350	400

All dimensions in mm.

Table 4- 14 Field data SIMATIC RF290R, with ANT D10 (at 4 W)

	Length of the transmission window (L)		Operating distance (S _a)	Limit distance (S _g)
	X direction	Y direction		
MDS D100	1050	350	0 ... 500	600
MDS D124	1000	300	0 ... 200	280
MDS D126	1050	350	0 ... 400	500
MDS D139	1050	350	0 ... 450	550
MDS D160	1000	300	0 ... 130	180
MDS D165	1050	350	0 ... 350	450
MDS D200	1050	350	0 ... 450	550
MDS D261	1050	350	0 ... 350	450
MDS D324	1000	300	0 ... 200	280
MDS D339	1050	350	0 ... 300	380
MDS D400	1050	350	0 ... 400	500
MDS D424	1000	300	0 ... 200	280
MDS D426	1050	350	0 ... 350	400
MDS D524	1000	300	0 ... 220	300
MDS D526	1050	350	0 ... 350	400

All dimensions in mm.

4.2.2 Minimum clearances

Minimum distance from transponder to transponder

The specified distances refer to a metal-free environment. For a metallic environment, the specified minimum distances must be multiplied by a factor of 1.5. The transponders designed specifically for installation in/on metal are an exception to this.

Table 4- 15 Minimum clearances for transponders

	RF210R	RF220R	RF240R	RF260R	RF280R
MDS D100	--	--	--	≥ 240	≥ 420
MDS D117	≥ 15	--	--	--	--
MDS D124	≥ 25	≥ 40	≥ 90	≥ 180	≥ 360
MDS D126	--	≥ 50	≥ 100	≥ 180	≥ 400
MDS D127	≥ 15	--	--	--	--
MDS D139	--	--	--	≥ 200	≥ 450
MDS D160	≥ 20	≥ 25	≥ 70	≥ 150	≥ 300
MDS D165	--	--	--	≥ 240	≥ 500
MDS D200	--	--	--	≥ 240	≥ 500
MDS D261	--	--	--	≥ 200	≥ 400
MDS D324	≥ 25	≥ 40	≥ 90	≥ 180	≥ 360
MDS D339	--	--	--	≥ 200	≥ 450
MDS D400	--	--	--	≥ 240	≥ 500
MDS D421	≥ 10	--	--	--	--
MDS D422	≥ 15	≥ 20	≥ 50	--	--
MDS D423	--	--	≥ 80	≥ 160	≥ 250
MDS D424	≥ 25	≥ 40	≥ 90	≥ 180	≥ 360
MDS D425	≥ 20	≥ 25	≥ 75	--	≥ 250
MDS D426	--	≥ 50	≥ 90	≥ 180	≥ 400
MDS D428	≥ 25	≥ 25	≥ 75	≥ 150	≥ 300
MDS D460	≥ 20	≥ 25	≥ 70	≥ 150	≥ 300
MDS D521	≥ 10	--	--	--	--
MDS D522	≥ 15	≥ 20	≥ 50	--	--
MDS D522 Special variants	≥ 15	≥ 20	≥ 50	--	--
MDS D524	≥ 25	≥ 40	≥ 90	≥ 180	≥ 360
MDS D526	--	≥ 50	≥ 90	≥ 180	≥ 400
MDS D528	≥ 25	≥ 25	≥ 75	≥ 150	≥ 300

All values are in mm, relative to the operating distance (S_a) between reader and transponder, and between transponder edge and transponder edge

Table 4- 16 Minimum clearances for transponders

	RF250R ¹⁾					RF290R ²⁾		
	ANT 3	ANT 8	ANT 12	ANT 18	ANT 30	ANT D5	ANT D6	ANT D10
MDS D100	--	--	--	--	--	≥ 1000	≥ 1500	≥ 2000
MDS D117	--	≥ 30	≥ 50	--	--	--	--	--
MDS D124	≥ 100	--	--	≥ 80	≥ 100	≥ 800	≥ 1200	≥ 1800
MDS D126	≥ 100	--	--	--	≥ 100	≥ 1000	≥ 1500	≥ 2000
MDS D127	--	≥ 40	≥ 60	--	--	--	--	--
MDS D139	--	--	--	--	--	≥ 1000	≥ 1500	≥ 2000
MDS D160	≥ 100	--	≥ 60	≥ 80	≥ 100	≥ 800	≥ 1200	≥ 1800
MDS D165	--	--	--	--	--	≥ 1000	≥ 1500	≥ 2000
MDS D200	--	--	--	--	--	≥ 1000	≥ 1500	≥ 2000
MDS D261	--	--	--	--	--	≥ 1000	≥ 1500	≥ 2000
MDS D324	≥ 100	--	--	≥ 80	≥ 100	≥ 800	≥ 1200	≥ 1800
MDS D339	--	--	--	--	--	≥ 1000	≥ 1500	≥ 2000
MDS D400	--	--	--	--	--	≥ 1000	≥ 1500	≥ 2000
MDS D421	--	≥ 30	≥ 40	≥ 50	--	--	--	--
MDS D422	≥ 70	--	≥ 50	≥ 60	≥ 70	--	--	--
MDS D423	≥ 100	--	--	≥ 80	≥ 100	--	--	--
MDS D424	≥ 100	--	--	≥ 80	≥ 100	≥ 800	≥ 1200	≥ 1800
MDS D425	≥ 80	--	≥ 50	≥ 60	≥ 80	--	--	--
MDS D426	≥ 100	--	--	--	≥ 100	≥ 800	≥ 1200	≥ 1800
MDS D428	≥ 80	--	≥ 50	≥ 60	≥ 80	--	--	--
MDS D460	≥ 100	--	≥ 60	≥ 80	≥ 100	≥ 800	--	--
MDS D521	--	≥ 30	≥ 40	≥ 50	--	--	--	--
MDS D522	≥ 70	--	≥ 50	≥ 60	≥ 70	--	--	--
MDS D522 Special variants	≥ 70	--	≥ 50	≥ 60	≥ 70	--	--	--
MDS D524	≥ 100	--	--	≥ 80	≥ 100	≥ 800	≥ 1200	≥ 1800
MDS D526	≥ 100	--	--	--	≥ 100	≥ 800	≥ 1200	≥ 1800
MDS D528	≥ 80	--	≥ 50	≥ 60	≥ 80	--	--	--

¹⁾ Depends on the connected antenna (ANT 3, 8, 12, 18 or 30).

²⁾ Depends on the connected antenna (ANT D5, D6 or D10).

All values are in mm, relative to the operating distance (S_a) between reader and transponder, and between transponder edge and transponder edge

Minimum distance from reader to reader

Table 4- 17 Minimum distances to readers or antennas

RF210R to RF210R	RF220R to RF220R	RF240R to RF240R	ANT x to ANT x with RF250R	RF260R to RF260R	RF280R to RF280R	ANT Dx to ANT Dx with RF290R
≥ 60	≥ 100	≥ 120	ANT 3: ≥ 100	≥ 150	with 2 readers ≥ 400 with multiple readers ≥ 500	ANT D5: ≥ 2000
			ANT 8: ≥ 50			ANT D10: ≥ 2000
			ANT 12: ≥ 60			
			ANT 18: ≥ 80			
			ANT 30: ≥ 100			

All values are in mm

Note

Effect on inductive fields by not maintaining the minimum distances of the readers

If the values fall below those specified in the "minimum distance readers or antennas", there is a risk of the function being affected by inductive fields. In this case, the data transfer time would increase unpredictably or a command would be aborted with an error.

Keeping to the values specified in the "Minimum distance readers or antennas" table is therefore essential.

If the specified minimum distance cannot be complied with due to the physical configuration, the SET-ANT command can be used to activate and deactivate the HF field of the reader. The application software must be used to ensure that only one reader is active (antenna is switched on) at a time.

4.3 Installation guidelines

4.3.1 Overview

The transponder and reader complete with their antennas are inductive devices. Any type of metal in the vicinity of these devices affects their functionality. Some points need to be considered during planning and installation if the values described in the "Field data (Page 39)" section are to retain their validity:

- Minimum spacing between two readers or their antennas
- Minimum distance between two adjacent data memories
- Metal-free area for flush-mounting of readers or their antennas and transponders in metal
- Mounting of multiple readers or their antennas on metal frames or racks

The following sections describe the impact on the operation of the RFID system when mounted in the vicinity of metal.

4.3.2 Reduction of interference due to metal

Table 4- 18 Interference due to metal rack

Representation	Description
 <p>The diagram illustrates a cross-section of an RFID system. At the top, a horizontal bar represents a 'Metal rack'. Below it, a 'Non-metallic spacer' is positioned. Underneath the spacer is a 'Transponder'. A double-headed arrow labeled 'Sa' indicates the distance between the 'Readers' (located below the transponder) and the 'Transponder'. At the bottom, a thick grey bar represents 'Metal'.</p>	<p>Problem: A metal rack is located above the transmission window of the reader. This affects the entire field. In particular, the transmission window between reader and transponder is reduced.</p>
 <p>This diagram shows a modified setup. The 'Metal rack' is now positioned further to the left, so it no longer overlaps the area between the 'Readers' and the 'Transponder'. The 'Transponder' is still above the 'Readers', and the 'Metal' sheet remains at the bottom.</p>	<p>Remedy: The transmission window is no longer affected if the transponder is mounted differently.</p>

Table 4- 19 Flush-mounting of transponders and readers

Representation	Description
	<p>Problem:</p> <p>Flush-mounting of transponders and readers is possible in principle. However, the size of the transmission window is significantly reduced. The following measures can be used to counteract the reduction of the window:</p>
	<p>Remedy:</p> <p>Enlargement of the non-metallic spacer below the transponder and/or reader.</p> <p>The transponder and/or reader are 10 to 20 mm higher than the metal surround.</p> <p>(The value $x \geq 100$ mm is valid, for example, for RF260R. It indicates that, for a distance $x \geq 100$ mm, the reader can no longer be significantly affected by metal.)</p>
	<p>Remedy:</p> <p>Increase the distances a, b to metal.</p> <p>The following rule of thumb can be used:</p> <ul style="list-style-type: none"> • Increase a, b by a factor of 2 to 3 over the values specified for metal-free areas • Increasing a, b has a greater effect for readers or transponders with a large limit distance than for readers or transponders with a small limit distance.

Mounting of several readers on metal frames or racks

Any reader mounted on metal couples part of the field to the metal frame. There is normally no interaction as long as the minimum distance D and metal-free areas a , b are maintained. However, interaction may take place if an iron frame is positioned unfavorably. Longer data transfer times or sporadic error messages at the communication module are the result.

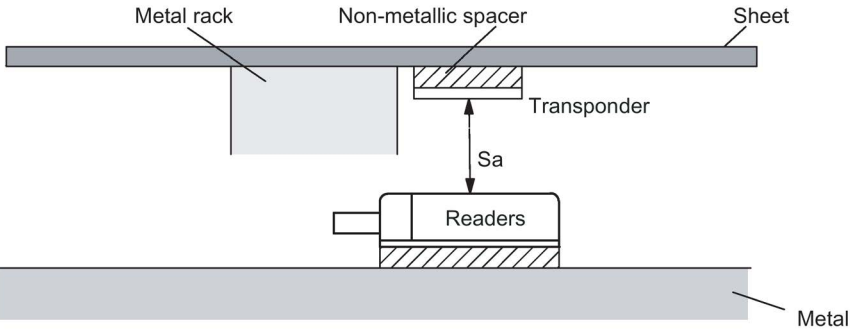
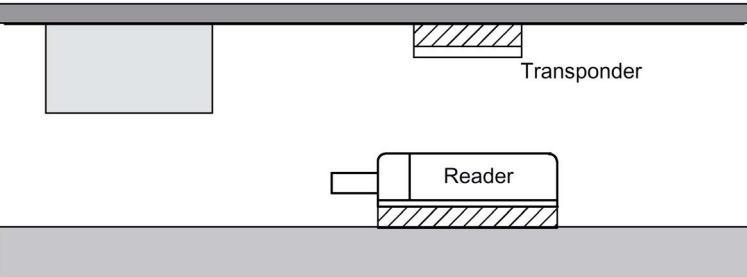
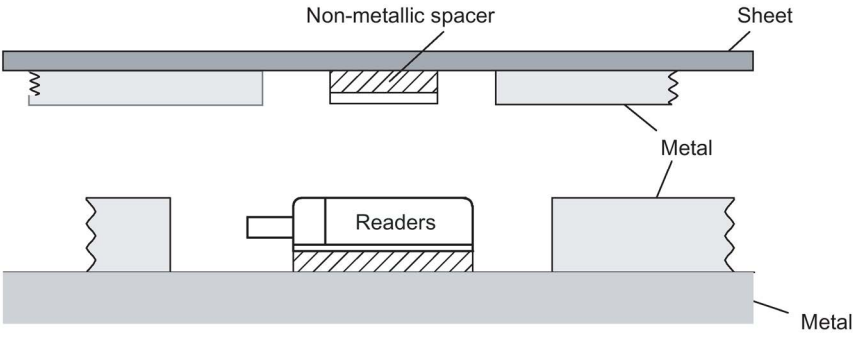
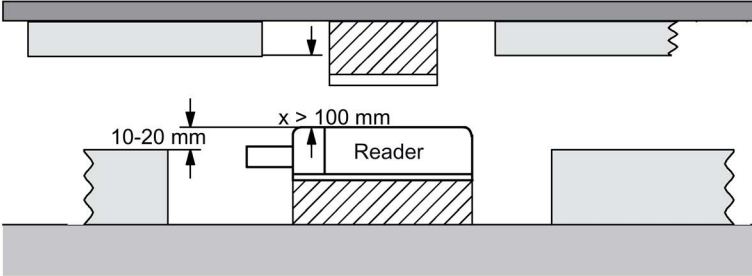
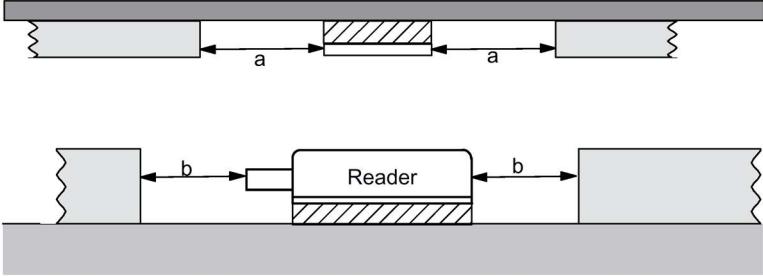
Table 4- 20 Mounting of several readers on metal frames or racks

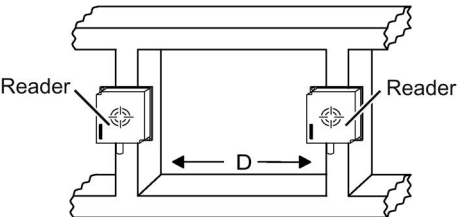
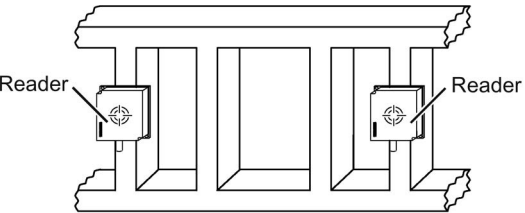
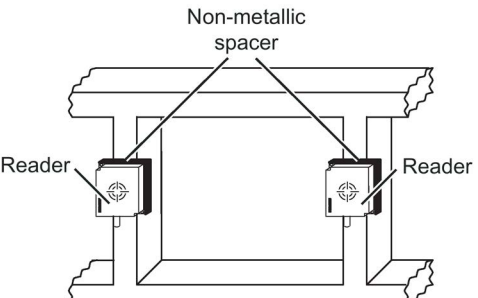
Representation	Description
 <p>The diagram shows two rectangular readers mounted on a metal frame. A double-headed arrow between the two readers is labeled 'D', representing the distance between them.</p>	<p>Problem: Interaction between readers</p> <p>Remedy: Increase the distance D between the two readers.</p>
 <p>The diagram shows two rectangular readers mounted on a metal frame. Vertical iron struts are placed between the readers to short-circuit stray fields.</p>	<p>Remedy: Introduce one or more iron struts in order to short-circuit the stray fields.</p>
 <p>The diagram shows two rectangular readers mounted on a metal frame. Non-metallic spacers are placed between the readers and the metal frame to reduce stray field induction.</p>	<p>Remedy: Insert a non-metallic spacer of 20 to 40 millimeter thickness between the reader and the iron frame. This will significantly reduce the induction of stray fields on the rack:</p>

4.3.3 Effects of metal on different transponders and readers

Mounting different transponders and readers on metal or flush-mounting

Certain conditions have to be observed when mounting the transponders and readers on metal or flush-mounting. For more information, please refer to the descriptions of the individual transponders and readers in the relevant section.

4.3.4 Impact of metal on the transmission window

In general, the following points should be considered when mounting RFID components:

- Direct mounting on metal is allowed only in the case of specially approved transponders.
- Flush-mounting of the components in metal reduces the field data; a test is recommended in critical applications.
- When working inside the transmission window, make sure that no metal rail (or similar part) intersects the transmission field.
The metal rail would affect the field data.
- With readers with a large antenna surface (e.g. RF340R) for reasons of communication reliability, when the transponders are flush-mounted in metal, a metal-free space around the transponders is recommended. This metal-free space should match the size of the antenna surface.
- The reduction of field data is also based on the minimum distance between the reader and transponder. The respective recommendations are listed in the following table.

The impact of metal on the field data (S_g , S_a , L) is shown in a table in this section. The values in the tables describe field data reduction and show the reduced range as a percentage. The range relates to use in a non-metallic environment. A value of 100% means no influence on the range.

Note

Possible reader-transponder combinations

The tables of the following section show the possible reader-transponder combinations.

4.3.4.1 RF210R

The RF210R can be flush-mounted in metal. Please allow for a possible reduction in the field data values. To avoid reduction in the case of d), the distance a should be ≥ 10 mm.

The following table shows the different arrangements for the reader with and without a metallic environment:

Case	Diagram	Description
a)		Reader metal-free
b)		Reader on metal, distance from metal ≥ 12 mm
c)		Reader in metal, flush against M18 nut
d)		Reader in metal, all around

Table 4- 21 Reduction of field data due to metal, range as %: Transponder and RF210R

Transponder		Reader without direct metal influence (Case a, b and d)	Reader flush-mounted in metal (Case c)
MDS D124 ¹⁾	Metal-free	100	82
	On metal, distance 15 mm	90	90
	Flush-mounted in metal; distance all round 15 mm	85	80
MDS D127	Flush-mounted in metal; distance all round 0 mm	100	75
MDS D160 ¹⁾	Metal-free	100	95
	On metal, distance 10 mm	100	95
MDS D324 ¹⁾	Metal-free	100	90
	On metal, distance 15 mm	90	90
	Flush-mounted in metal; distance all round 25 mm	80	90
MDS D421	Metal-free	100	90
	Flush-mounted in metal; distance all round 0 mm	75	50
MDS D422	Metal-free	100	80
	Flush-mounted in metal; distance all round 0 mm	90	40
MDS D423	Metal-free	100	90
	On metal, distance 0 mm	110 ²⁾	100 ²⁾
	Flush-mounted in metal; distance all round 10 mm	95	85
MDS D424 ¹⁾	Metal-free	100	60
	On metal, distance 15 mm	90	80
	Flush-mounted in metal; distance all round 25 mm	85	75
MDS D425	Metal-free	100	85
	On metal, distance 0 mm	100	85
MDS D428	Metal-free	100	90
	On metal, distance 0 mm	100	80
MDS D460 ¹⁾	Metal-free	100	90
	On metal, distance 25 mm	100	90
MDS D521	Metal-free	100	90
	Flush-mounted in metal; distance all round 0 mm	75	50
MDS D522	Metal-free	100	80
	Flush-mounted in metal; distance all round 0 mm	90	40
MDS D522 Special variants	Metal-free	100	80
	Flush-mounted in metal; distance all round 0 mm	90	40

Transponder		Reader without direct metal influence (Case a, b and d)	Reader flush-mounted in metal (Case c)
MDS D524 ¹⁾	Metal-free	100	60
	On metal, distance 15 mm	90	80
	Flush-mounted in metal; distance all round 25 mm	85	75
MDS D528	Metal-free	100	90
	On metal, distance 0 mm	100	80

- ¹⁾ Mounting the transponder on or in metal is only possible with the appropriate spacer or if there is adequate clearance to the metal.
- ²⁾ Values of > 100 % related to non metal surroundings can occur if transponders were developed specifically for mounting in/on metallic surroundings.

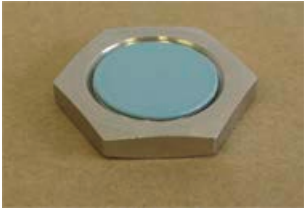
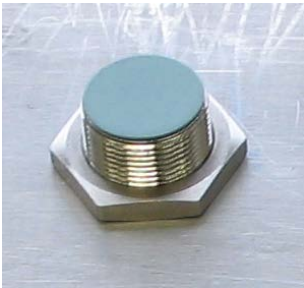
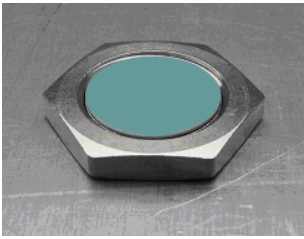
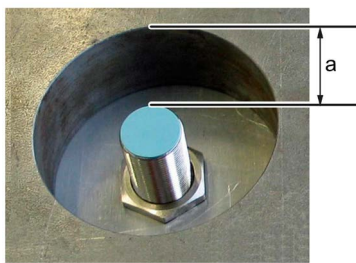
4.3.4.2 RF220R

The RF220R can be flush-mounted in metal. Please allow for a possible reduction in the field data values. To avoid reduction in the case of d), the distance a should be ≥ 15 mm.

The following table shows the different arrangements for the reader with and without a metallic environment:



Case	Diagram	Description
a)		Reader metal-free
b)		Reader on metal, distance from metal ≥ 12 mm
c)		Reader in metal, flush against M30 nut
d)		Reader in metal, all round

Table 4- 22 Reduction of field data due to metal, range as %: Transponder and RF220R

Transponder		Reader without direct metal influence (Case a, b and d)	Reader flush-mounted in metal (Case c)
MDS D124 ¹⁾	Metal-free	100	94
	On metal, distance 15 mm	97	89
	Tag flush-mounted in metal; distance all round 15 mm	86	83
MDS D126 ¹⁾	Metal-free	100	75
	On metal, distance 25 mm	85	70
	Flush-mounted in metal; distance all round 50 mm	80	65
MDS D160 ¹⁾	Metal-free	100	89
	On metal, distance 10 mm	100	89
MDS D324 ¹⁾	Metal-free	100	90
	On metal, distance 15 mm	97	86
	Flush-mounted in metal; distance all round 25 mm	93	86
MDS D422	Metal-free	100	90
	Flush-mounted in metal; distance all round 0 mm	85	85
MDS D423	Metal-free	100	90
	On metal, distance 0 mm	125 ²⁾	115 ²⁾
	Flush-mounted in metal; distance all round 10 mm	80	75
MDS D424 ¹⁾	Metal-free	100	93
	On metal, distance 15 mm	96	89
	Flush-mounted in metal; distance all round 25 mm	86	82
MDS D425	Metal-free	100	90
	Screwed onto metal	100	75
	Flush-mounted in metal; distance all round 25 mm	95	75
MDS D426 ¹⁾	Metal-free	100	90
	On metal, distance 25 mm	90	75
	Flush-mounted in metal; distance all round 50 mm	80	70
MDS D428	Metal-free	100	94
	On metal, distance 0 mm	100	94
MDS D460 ¹⁾	Metal-free	100	92
	On metal, distance 0 mm	100	92
MDS D522	Metal-free	100	90
	Flush-mounted in metal; distance all round 0 mm	85	85

Transponder		Reader without direct metal influence (Case a, b and d)	Reader flush-mounted in metal (Case c)
MDS D522 Special variants	Metal-free	100	90
	Flush-mounted in metal; distance all round 0 mm	85	85
MDS D524 ¹⁾	Metal-free	100	93
	On metal, distance 0 mm	96	89
	Flush-mounted in metal; distance all round 0 mm	86	82
MDS D526 ¹⁾	Metal-free	100	90
	On metal, distance 25 mm	90	75
	Flush-mounted in metal; distance all round 50 mm	80	70
MDS D528	Metal-free	100	94
	On metal, distance 0 mm	100	94

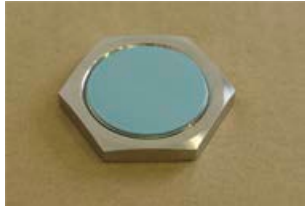
- 1) Mounting the transponder on or in metal is only possible with the appropriate spacer or if there is adequate clearance to the metal.
- 2) Values of > 100 % related to non metal surroundings can occur if transponders were developed specifically for mounting in/on metallic surroundings.

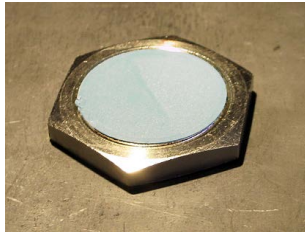
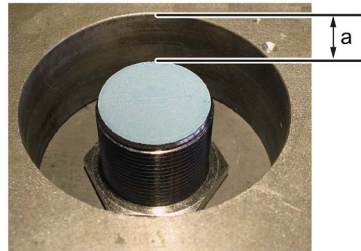
4.3.4.3 RF240R

The RF240R can be flush-mounted in metal. Please allow for a possible reduction in the field data values. To avoid reduction, the distance a should be ≥ 20 mm.

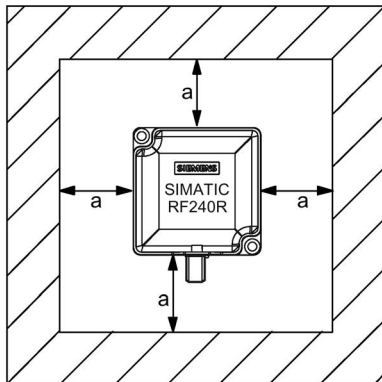

Figure 4-11 Metal-free space RF240R

Table 4- 23 Reduction of field data due to metal, range as %: Transponder and RF240R

Transponder		Reader without direct metal influence	Reader on metal (metal plate)	Reader flush-mounted in metal (all round 20 mm)
MDS D100 ¹⁾	Without metal	100	95	80
	On metal, distance 20 mm	95	90	75
	Flush-mounted in metal; distance all round 20 mm	90	75	70
MDS D124 ¹⁾	Without metal	100	85	75
	On metal, distance 15 mm	90	80	75
	Flush-mounted in metal; distance all round 25 mm	85	70	65
MDS D126 ¹⁾	Without metal	100	80	70
	On metal, distance 25 mm	80	75	60
	Flush-mounted in metal; distance all round 50 mm	70	55	55
MDS D160 ¹⁾	Without metal	100	90	80
	On metal, distance 10 mm	90	85	80
MDS D165	Without metal	100	95	75
	On metal, distance 25 mm	75	70	65
MDS D200 ¹⁾	Without metal	100	95	85
	On metal, distance 20 mm	95	80	70
	Flush-mounted in metal, distance all round 20 mm	70	60	50
MDS D261	Without metal	100	90	90
	On metal, distance 25 mm	85	80	70
MDS D324 ¹⁾	Without metal	100	90	80
	On metal, distance 15 mm	95	85	80
	Flush-mounted in metal; distance all round 25 mm	90	75	70
MDS D400 ¹⁾	Without metal	100	90	80
	On metal, distance 20 mm	80	75	55
	Flush-mounted in metal, distance all round 20 mm	75	70	50
MDS D422	Without metal	100	90	85
	Flush-mounted in metal; distance all round 0 mm	90	60	40
MDS D423	Without metal	100	95	90
	On metal, distance 0 mm	150 ²⁾	140 ²⁾	140 ²⁾
	Flush-mounted in metal; distance all round 10 mm	70	60	60
MDS D424 ¹⁾	Without metal	100	85	80
	On metal, distance 15 mm	90	80	75

Transponder		Reader without direct metal influence	Reader on metal (metal plate)	Reader flush-mounted in metal (all round 20 mm)
	Flush-mounted in metal; distance all round 25 mm	80	70	65
MDS D425	Without metal	100	90	85
	On metal, distance 0 mm	95	85	80
MDS D426 ¹⁾	Without metal	100	80	70
	On metal, distance 25 mm	90	80	70
	Flush-mounted in metal; Distance all-round 50 mm	85	65	60
MDS D428	Without metal	100	90	85
	On metal, distance 0 mm	95	85	83
MDS D460 ¹⁾	Without metal	100	90	80
	On metal, distance 0 mm	90	85	80
MDS D522	Metal-free	100	90	85
	Flush-mounted in metal; distance all round 0 mm	90	60	40
MDS D522 Special variant	Metal-free	100	90	85
	Flush-mounted in metal; distance all round 0 mm	90	60	40
MDS D524 ¹⁾	Metal-free	100	85	80
	On metal, distance 0 mm	90	80	75
	Flush-mounted in metal; distance all round 0 mm	80	70	65
MDS D526 ¹⁾	Metal-free	100	80	70
	On metal, distance 25 mm	90	80	70
	Flush-mounted in metal; distance all round 50 mm	85	65	60
MDS D528	Metal-free	100	90	85
	On metal, distance 0 mm	95	85	83

1) Mounting the transponder on or in metal is only possible with the appropriate spacer or if there is adequate clearance to the metal.

2) Values of > 100 % related to non metal surroundings can occur if transponders were developed specifically for mounting in/on metallic surroundings.

4.3.4.4 RF250R

The RF250R reader is operated with the external antennas ANT 3, 8, 12, 18 and 30. The antennas can be flush-mounted in metal. Please allow for a possible reduction in the field data values.

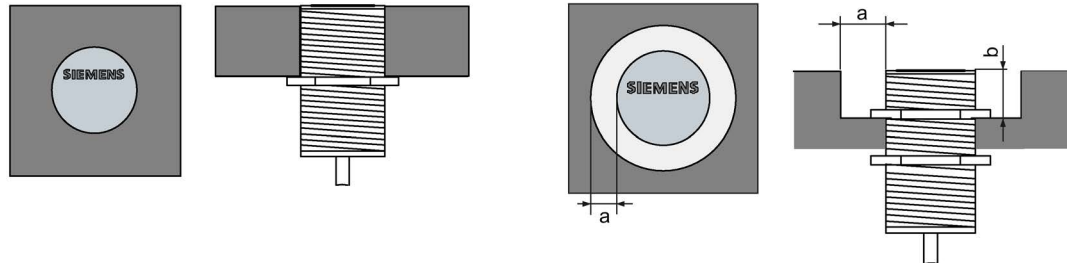

Figure 4-12 Metal-free space for ANT 8 / ANT 12 and ANT 18 / ANT 30

Table 4- 24 Reduction of field data due to metal, range as %: Transponder and RF250R with ANT 1

Transponder		ANT 1 without metal	ANT 1 on metal	ANT 1 mounted in metal (all round 40 mm)
MDS D100 ¹⁾	Without metal	100	85	80
	On metal; distance 20 mm	70	60	65
	Flush-mounted in metal; distance all round 20 mm	60	45	45
MDS D124 ¹⁾	Without metal	100	95	85
	On metal; distance 15 mm	85	85	80
	Flush-mounted in metal; distance all round 20 mm	85	80	50
MDS D126 ¹⁾	Without metal	100	85	85
	On metal; distance 25 mm	85	75	75
	Flush-mounted in metal; distance all round 50 mm	80	70	70
MDS D139 ¹⁾	Without metal	100	90	85
	On metal; distance 30 mm	95	85	85
	Flush-mounted in metal; distance all round 100 mm	95	85	85
MDS D160 ¹⁾	Without metal	100	95	90
	On metal; distance 10 mm	85	85	80
MDS D165	Without metal	100	85	85
	On metal; distance 25 mm	90	80	75
MDS D200 ¹⁾	Without metal	100	85	80
	On metal; distance 20 mm	85	75	75
	Flush-mounted in metal; distance all round 20 mm	75	65	65

Transponder		ANT 1 without metal	ANT 1 on metal	ANT 1 mounted in metal (all round 40 mm)
MDS D261	Without metal	100	90	85
	On metal; distance 25 mm	85	80	80
MDS D324¹⁾	Without metal	100	85	85
	On metal; distance 15 mm	90	80	80
	Flush-mounted in metal; distance all round 25 mm	80	75	65
MDS D339¹⁾	Without metal	100	90	85
	On metal; distance 30 mm	95	85	85
	Flush-mounted in metal; distance all round 100 mm	95	85	85
MDS D400¹⁾	Without metal	100	90	85
	On metal; distance 20 mm	80	70	65
	Flush-mounted in metal; distance all round 20 mm	65	60	60
MDS D423	Without metal	100	90	90
	On metal; distance 0 mm	115 ²⁾	115 ²⁾	115 ²⁾
	Flush-mounted in metal; distance all round 0 mm	80	65	65
MDS D424¹⁾	Without metal	100	90	75
	On metal; distance 15 mm	85	80	75
	Flush-mounted in metal; distance all round 25 mm	75	70	70
MDS D425	Without metal	100	95	95
	On metal; distance 0 mm	90	85	85
MDS D426¹⁾	Without metal	100	90	85
	On metal; distance 25 mm	85	80	75
	Flush-mounted in metal; distance all round 50 mm	80	75	70
MDS D428	Without metal	100	90	85
	On metal; distance 0 mm	85	80	80
MDS D460¹⁾	Without metal	100	90	80
	On metal; distance 10 mm	85	80	75
MDS D524¹⁾	Without metal	100	90	75
	On metal; distance 15 mm	85	80	75
	Flush-mounted in metal; distance all round 25 mm	75	70	70
MDS D525	Without metal	100	95	95
	On metal; distance 0 mm	90	85	85
MDS D526¹⁾	Without metal	100	90	85
	On metal; distance 25 mm	85	80	75

Transponder		ANT 1 without metal	ANT 1 on metal	ANT 1 mounted in metal (all round 40 mm)
	Flush-mounted in metal; distance all round 50 mm	80	75	70
MDS D528	Without metal	100	90	85
	On metal; distance 0 mm	85	80	80

- 1) Mounting the transponder on or in metal is only possible with the appropriate spacer or if there is adequate clearance to the metal.
- 2) Values of > 100 % can occur if transponders were developed specifically for mounting in/on metallic surroundings.

Table 4- 25 Reduction of field data due to metal, range as %: Transponder and RF250R with ANT 3

Transponder		RF250R with ANT 3	
		Antenna without metal	Antenna flush-mounted in metal (all round 20 mm)
MDS D124 ¹⁾	Without metal	100	80
	On metal, distance 15 mm	90	75
	Flush-mounted in metal; distance all round 25 mm	75	70
MDS D126 ¹⁾	Without metal	100	80
	On metal, distance 25 mm	85	75
	Flush-mounted in metal; distance all round 50 mm	60	50
MDS D160 ¹⁾	Without metal	100	85
	On metal, distance 10 mm	95	80
MDS D324 ¹⁾	Without metal	100	80
	On metal, distance 15 mm	95	75
	Flush-mounted in metal; distance all round 25 mm	85	70
MDS D422	Without metal	100	95
	Flush-mounted in metal; distance all round 0 mm	95	80
MDS D423	Without metal	100	90
	On metal, distance 0 mm	130 ²⁾	110 ²⁾
	Flush-mounted in metal; distance all round 10 mm	80	70
MDS D424 ¹⁾	Without metal	100	85
	On metal, distance 15 mm	90	75
	Flush-mounted in metal; distance all round 25 mm	75	70

Transponder		RF250R with ANT 3	
		Antenna without metal	Antenna flush-mounted in metal (all round 20 mm)
MDS D425	Without metal	100	90
	On metal, distance 0 mm	95	75
MDS D426 ¹⁾	Without metal	100	70
	On metal, distance 25 mm	90	65
	Flush-mounted in metal; distance all round 25 mm	55	45
MDS D428	Without metal	100	90
	On metal, distance 0 mm	100	90
MDS D460 ¹⁾	Without metal	100	85
	On metal, distance 10 mm	90	75
MDS D522	Without metal	100	95
	Flush-mounted in metal; distance all round 0 mm	95	80
MDS D522 Special variants	Without metal	100	95
	Flush-mounted in metal; distance all round 0 mm	95	80
MDS D524 ¹⁾	Without metal	100	85
	On metal, distance 15 mm	90	75
	Flush-mounted in metal; distance all round 25 mm	75	70
MDS D526 ¹⁾	Without metal	100	70
	On metal, distance 25 mm	90	65
	Flush-mounted in metal; distance all round 25 mm	55	45
MDS D528	Without metal	100	90
	On metal, distance 0 mm	100	90

- 1) Mounting the transponder on or in metal is only possible with the appropriate spacer or if there is adequate clearance to the metal.
- 2) Values of > 100 % related to non metal surroundings can occur if transponders were developed specifically for mounting in/on metallic surroundings.

Table 4- 26 Reduction of field data due to metal, range as %: Transponder and RF250R with ANT 8

Transponder		RF250R with ANT 8	
		Antenna without metal	Antenna flush-mounted in metal
MDS D117	Without metal	100	85
	Flush-mounted in metal; distance all round 0 mm	65	55
MDS D127	Without metal	100	85
	Flush-mounted in metal; distance all round 0 mm	70	60
MDS D421	Without metal	100	85
	Flush-mounted in metal; distance all round 0 mm	75	70
MDS D521	Without metal	100	85
	Flush-mounted in metal; distance all round 0 mm	75	70

Table 4- 27 Reduction of field data due to metal, range as %: Transponder and RF250R with ANT 12

Transponder		RF250R with ANT 12	
		Antenna without metal	Antenna flush-mounted in metal (all round 7 mm)
MDS D117	Without metal	100	85
	Flush-mounted in metal; distance all round 0 mm	50	40
MDS D127	Without metal	100	85
	Flush-mounted in metal; distance all round 0 mm	65	50
MDS D160 ¹⁾	Without metal	100	90
	On metal, distance 10 mm	90	85
MDS D421	Without metal	100	90
	Flush-mounted in metal; distance all round 0 mm	65	45
MDS D422	Without metal	100	90
	Flush-mounted in metal; distance all round 0 mm	90	75
MDS D425	Without metal	100	90
	On metal, distance 0 mm	115 ²⁾	100
MDS D428	Without metal	100	85
	On metal, distance 0 mm	110 ²⁾	95
MDS D460 ¹⁾	Without metal	100	95
	On metal, distance 10 mm	90	80
	Flush-mounted in metal; distance all round 0 mm	85	75

Transponder		RF250R with ANT 12	
		Antenna without metal	Antenna flush-mounted in metal (all round 7 mm)
MDS D521	Without metal	100	90
	Flush-mounted in metal; distance all round 0 mm	65	45
MDS D522	Without metal	100	90
	Flush-mounted in metal; distance all round 0 mm	90	75
MDS D528	Without metal	100	85
	On metal, distance 0 mm	110 ²⁾	95

- 1) Mounting the transponder on or in metal is only possible with the appropriate spacer or if there is adequate clearance to the metal.
- 2) Values of > 100 % related to non metal surroundings can occur if transponders were developed specifically for mounting in/on metallic surroundings.

Table 4- 28 Reduction of field data due to metal, range as %: Transponder and RF250R with ANT 18

Transponder		RF250R with ANT 18	
		Antenna without metal	Antenna flush-mounted in metal (all round 10 mm)
MDS D124 ¹⁾	Without metal	100	80
	On metal, distance 15 mm	100	80
	Flush-mounted in metal; distance all round 25 mm	95	70
MDS D160 ¹⁾	Without metal	100	90
	On metal, distance 10 mm	100	90
MDS D324 ¹⁾	Without metal	100	80
	On metal, distance 15 mm	100	80
	Flush-mounted in metal; distance all round 25 mm	95	75
MDS D421	Without metal	100	85
	Flush-mounted in metal; distance all round 0 mm	65	50
MDS D422	Without metal	100	100
	Flush-mounted in metal; distance all round 0 mm	90	90
MDS D423	Without metal	100	85
	On metal, distance 0 mm	120 ²⁾	110 ²⁾
	Flush-mounted in metal; distance all round 10 mm	90	75
MDS D424 ¹⁾	Without metal	100	75
	On metal, distance 15 mm	95	75

Transponder	RF250R with ANT 18		
	Antenna without metal	Antenna flush-mounted in metal (all round 10 mm)	
	Flush-mounted in metal; distance all round 25 mm	95	75
MDS D425	Without metal	100	90
	On metal, distance 0 mm	100	90
MDS D428	Without metal	100	85
	On metal, distance 0 mm	100	85
MDS D460 ¹⁾	Without metal	100	85
	On metal, distance 10 mm	100	85
MDS D521	Without metal	100	85
	Flush-mounted in metal; distance all round 0 mm	65	50
MDS D522	Without metal	100	100
	Flush-mounted in metal; distance all round 0 mm	90	90
MDS D522 Special variants	Without metal	100	100
	Flush-mounted in metal; distance all round 0 mm	90	90
MDS D524 ¹⁾	Without metal	100	75
	On metal, distance 15 mm	95	75
	Flush-mounted in metal; distance all round 25 mm	95	75
MDS D528	Without metal	100	85
	On metal, distance 0 mm	100	85

- ¹⁾ Mounting the transponder on or in metal is only possible with the appropriate spacer or if there is adequate clearance to the metal.
- ²⁾ Values of > 100 % related to non metal surroundings can occur if transponders were developed specifically for mounting in/on metallic surroundings.

Table 4- 29 Reduction of field data due to metal, range as %: Transponder and RF250R with ANT 30

Transponder		RF250R with ANT 30	
		Antenna without metal	Antenna flush-mounted in metal (all round 20 mm)
MDS D124 ¹⁾	Without metal	100	80
	On metal, distance 15 mm	90	75
	Flush-mounted in metal; distance all round 25 mm	75	70
MDS D126 ¹⁾	Without metal	100	80
	On metal, distance 25 mm	85	75
	Flush-mounted in metal; distance all round 50 mm	60	50
MDS D160 ¹⁾	Without metal	100	85
	On metal, distance 10 mm	95	80
MDS D324 ¹⁾	Without metal	100	80
	On metal, distance 15 mm	95	75
	Flush-mounted in metal; distance all round 25 mm	85	70
MDS D422	Without metal	100	95
	Flush-mounted in metal; distance all round 0 mm	95	80
MDS D423	Without metal	100	90
	On metal, distance 0 mm	130 ²⁾	110 ²⁾
	Flush-mounted in metal; distance all round 10 mm	80	70
MDS D424 ¹⁾	Without metal	100	85
	On metal, distance 15 mm	90	75
	Flush-mounted in metal; distance all round 25 mm	75	70
MDS D425	Without metal	100	90
	On metal, distance 0 mm	95	75
MDS D426 ¹⁾	Without metal	100	70
	On metal, distance 25 mm	90	65
	Flush-mounted in metal; distance all round 25 mm	55	45
MDS D428	Without metal	100	90
	On metal, distance 0 mm	100	90
MDS D460 ¹⁾	Without metal	100	85
	On metal, distance 10 mm	90	75
MDS D522	Without metal	100	95
	Flush-mounted in metal; distance all round 0 mm	95	80

Transponder		RF250R with ANT 30	
		Antenna without metal	Antenna flush-mounted in metal (all round 20 mm)
MDS D522 Special variants	Without metal	100	95
	Flush-mounted in metal; distance all round 0 mm	95	80
MDS D524 ¹⁾	Without metal	100	85
	On metal, distance 15 mm	90	75
	Flush-mounted in metal; distance all round 25 mm	75	70
MDS D526 ¹⁾	Without metal	100	70
	On metal, distance 25 mm	90	65
	Flush-mounted in metal; distance all round 25 mm	55	45
MDS D528	Without metal	100	90
	On metal, distance 0 mm	100	90

1) Mounting the transponder on or in metal is only possible with the appropriate spacer or if there is adequate clearance to the metal.

2) Values of > 100 % related to non metal surroundings can occur if transponders were developed specifically for mounting in/on metallic surroundings.

4.3.4.5 RF260R

The RF260R can be flush-mounted in metal. Please allow for a possible reduction in the field data values. To avoid reduction, the distance *a* should be ≥ 20 mm.

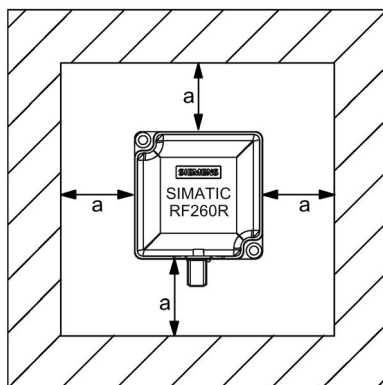

Figure 4-13 Metal-free space for RF260R

Table 4- 30 Reduction of field data due to metal, range as %: Transponder and RF260R

Transponder		Reader without metal direct metal influence	Reader on metal (metal plate)	Reader flush-mounted in metal (all round 20 mm)
MDS D100 ¹⁾	Without metal	100	85	65
	On metal, distance 20 mm	70	65	50
	Flush-mounted in metal; distance all round 20 mm ⁴⁾	65	50	40
MDS D124 ¹⁾	Without metal	100	93	75
	On metal, distance 15 mm	95	85	70
	Flush-mounted in metal; distance all round 25 mm ²⁾	78	75	65
MDS D126 ¹⁾	Without metal	100	85	73
	On metal, distance 25 mm	75	68	60
	Flush-mounted in metal; distance all round 50 mm ³⁾	55	53	40
MDS D139 ¹⁾	Without metal	100	90	75
	On metal; distance 30 mm ⁴⁾	95	90	75
MDS D160 ¹⁾	Without metal	100	90	75
	On metal, distance 10 mm	90	80	80
MDS D165	Without metal	100	85	65
	On metal; distance 25 mm ⁴⁾	65	60	45
MDS D200 ¹⁾	Without metal	100	85	70
	On metal, distance 20 mm	70	65	50
	Flush-mounted in metal, distance all round 20 mm ³⁾	55	50	45
MDS D261	Without metal	100	85	70
	On metal; distance 25 mm ³⁾	80	70	60
MDS D324 ¹⁾	Without metal	100	90	75
	On metal, distance 15 mm	90	80	70
	Flush-mounted in metal; distance all round 25 mm ²⁾	70	65	55
MDS D339 ¹⁾	Without metal	100	90	75
	On metal; distance 30 mm ⁴⁾	95	90	75
MDS D400 ¹⁾	Without metal	100	85	70
	On metal, distance 20 mm	70	65	50
	Flush-mounted in metal; distance all round 20 mm ⁴⁾	55	50	45
MDS D423	Without metal	100	95	85
	On metal, distance 0 mm	120 ⁵⁾	115 ⁵⁾	110 ⁵⁾
	Flush-mounted in metal; distance all round 10 mm ²⁾	75	65	60

Transponder		Reader without metal direct metal influence	Reader on metal (metal plate)	Reader flush-mounted in metal (all round 20 mm)
MDS D424 ¹⁾	Without metal	100	90	80
	On metal, distance 15 mm	90	80	70
	Flush-mounted in metal; distance all round 25 mm ²⁾	60	60	50
MDS D426 ¹⁾	Without metal	100	100	73
	On metal, distance 25 mm	88	85	68
	Flush-mounted in metal; distance all round 50 mm ³⁾	65	55	55
MDS D428	Without metal	100	90	90
	On metal, distance 0 mm	90	90	85
MDS D460 ¹⁾	Without metal	100	95	90
	On metal, distance 10 mm	90	85	80
MDS D524 ¹⁾	Without metal	100	90	80
	On metal, distance 15 mm	90	80	70
	Flush-mounted in metal; distance all round 25 mm ²⁾	60	60	50
MDS D526 ¹⁾	Without metal	100	100	73
	On metal, distance 25 mm	88	85	68
	Flush-mounted in metal; distance all round 50 mm ³⁾	65	55	55
MDS D528	Without metal	100	90	90
	On metal, distance 0 mm	90	90	85

¹⁾ Mounting the transponder on or in metal is only possible with the appropriate spacer or if there is adequate clearance to the metal.

²⁾ Transponder flush-mounted in metal; minimum distance to reader 5 mm

³⁾ Transponder flush-mounted in metal; minimum distance to reader 10 mm

⁴⁾ Transponder flush-mounted in metal; minimum distance to reader 15 mm

⁵⁾ Values > 100 % can occur if transponders were developed specifically for mounting in/on metallic surroundings.

4.3.4.6 RF280R

The RF280R can be flush-mounted in metal. Please allow for a possible reduction in the field data values. To avoid reduction, the distance a should be ≥ 20 mm.

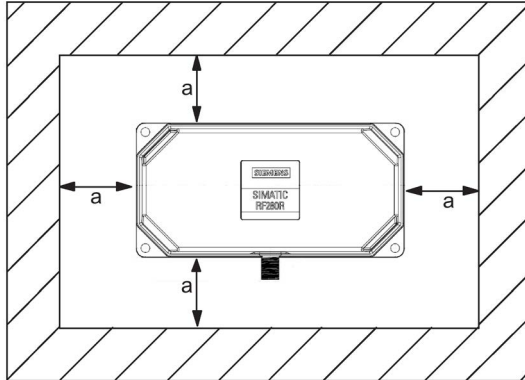

Figure 4-14 Metal-free area RF280R

Table 4- 31 Reduction of field data due to metal, range as %: Transponder and RF280R

Transponder		Reader without metal direct metal influence	Reader on metal (metal plate)	Flush-mounted in metal (20 mm all-round)
MDS D100 ¹⁾	Without metal	100	95	80
	On metal; distance 20 mm	65	60	55
	Flush-mounted in metal; distance all round 20 mm ²⁾	55	50	45
MDS D124 ¹⁾	Without metal	100	95	90
	On metal; distance 15 mm	95	90	85
	Flush-mounted in metal; distance all round 20 mm ²⁾	70	65	50
MDS D126 ¹⁾	Without metal	100	90	80
	On metal; distance 25 mm	80	75	70
	Flush-mounted in metal; distance all round 50 mm ³⁾	75	65	65
MDS D139 ¹⁾	Without metal	100	90	75
	On metal; distance 30 mm	95	85	70
	Flush-mounted in metal; distance all round 100 mm ⁴⁾	90	80	70
MDS D160 ¹⁾	Without metal	100	95	90
	On metal; distance 10 mm ²⁾	85	85	80
MDS D165	Without metal	100	90	80
	On metal; distance 25 mm ⁴⁾	80	75	70
MDS D200 ¹⁾	Without metal	100	90	80
	On metal; distance 20 mm	80	75	70

Transponder		Reader without metal direct metal influence	Reader on metal (metal plate)	Flush-mounted in metal (20 mm all-round)
	Flush-mounted in metal; distance all round 20 mm ³⁾	65	60	55
MDS D261	Without metal	100	95	85
	On metal; distance 25 mm ⁴⁾	85	80	75
MDS D324¹⁾	Without metal	100	95	85
	On metal; distance 15 mm	85	85	80
	Flush-mounted in metal; distance all round 25 mm ²⁾	70	65	60
MDS D339¹⁾	Without metal	100	90	80
	On metal; distance 30 mm	85	80	75
	Flush-mounted in metal; distance all round 100 mm ⁴⁾	80	75	70
MDS D400¹⁾	Without metal	100	90	80
	On metal; distance 20 mm	75	70	60
	Flush-mounted in metal; distance all round 20 mm ⁴⁾	60	60	55
MDS D423	Without metal	100	95	85
	On metal; distance 0 mm	100 ⁵⁾	100 ⁵⁾	90 ⁵⁾
	Flush-mounted in metal; distance all round 10 mm ²⁾	75	65	60
MDS D424¹⁾	Without metal	100	90	75
MDS D524¹⁾	On metal; distance 15 mm	75	75	60
	Flush-mounted in metal; distance all round 25 mm ²⁾	60	55	40
MDS D425	Without metal	100	70	90
MDS D525	On metal; distance 0 mm ²⁾	75	70	60
MDS D426¹⁾	Without metal	100	90	80
MDS D526¹⁾	On metal; distance 25 mm	80	75	70
	Flush-mounted in metal; distance all round 50 mm ³⁾	75	65	65
MDS D428	Without metal	100	90	80
MDS D528	On metal; distance 0 mm ²⁾	85	80	65
MDS D460¹⁾	Without metal	100	95	80
	On metal; distance 10 mm ²⁾	80	75	60

- 1) Mounting the transponder on or in metal is only possible with the appropriate spacer or if there is adequate clearance to the metal.
- 2) Transponder flush-mounted in metal; minimum distance to reader 5 mm
- 3) Transponder flush-mounted in metal; minimum distance to reader 10 mm
- 4) Transponder flush-mounted in metal; minimum distance to reader 15 mm
- 5) Values > 100 % in relation to non-metal surroundings can occur if transponders were developed specifically for mounting in/on metallic surroundings.

4.3.4.7 RF290R

The RF290R reader is operated with the external antennas ANT D5, D6 and D10. The antennas can be flush-mounted in metal. Please allow for a possible reduction in the field data values. To avoid reduction, the distance a should be ≥ 150 or 200 mm.

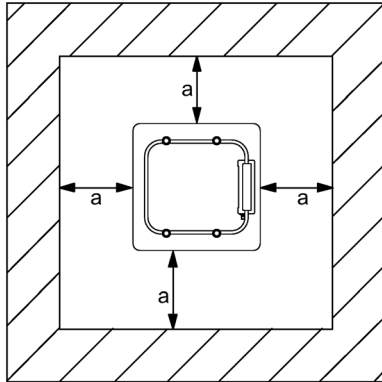

Figure 4-15 Metal-free space for ANT D5

Table 4- 32 Reduction of field data due to metal, range as %: Transponder and RF290R with ANT D5

Transponder		RF290R with ANT D5	
		Antenna on metal (metal plate)	Antenna flush-mounted in metal (all round 150 mm)
MDS D100 ¹⁾	Without metal	100	95
	On metal, distance 20 mm	65	60
	Flush-mounted in metal; distance all round 20 mm	45	40
MDS D124 ¹⁾	Without metal	100	95
	On metal, distance 15 mm	85	80
	Flush-mounted in metal; distance all round 25 mm	65	60
MDS D126 ¹⁾	Without metal	100	95
	On metal, distance 25 mm	70	65
	Flush-mounted in metal; distance all round 50 mm	55	50
MDS D139 ¹⁾	Without metal	100	95
	On metal, distance 30 mm	90	85
MDS D160 ¹⁾	Without metal	100	95
	On metal, distance 10 mm	70	65
MDS D165	Without metal	100	95
	On metal, distance 25 mm	65	60
MDS D200 ¹⁾	Without metal	100	95
	On metal, distance 20 mm	65	60

Transponder	RF290R with ANT D5		
	Antenna on metal (metal plate)	Antenna flush-mounted in metal (all round 150 mm)	
	Flush-mounted in metal; distance all round 20 mm	45	40
MDS D261	Without metal	100	95
	On metal, distance 25 mm	65	60
MDS D324 ¹⁾	Without metal	100	95
	On metal, distance 15 mm	75	70
MDS D339 ¹⁾	Without metal	100	95
	On metal, distance 30 mm	90	85
MDS D400 ¹⁾	Without metal	100	95
	On metal, distance 20 mm	65	60
	Flush-mounted in metal; distance all round 20 mm	45	40
MDS D424 ¹⁾	Without metal	100	95
	On metal, distance 15 mm	75	70
MDS D426 ¹⁾	Without metal	100	95
	On metal, distance 25 mm	70	65
	Flush-mounted in metal; distance all round 50 mm	50	45
MDS D460 ¹⁾	Without metal	100	95
	On metal, distance 10 mm	70	65

¹⁾ Mounting the transponder on or in metal is only possible with the appropriate spacer or if there is adequate clearance to the metal.

Table 4- 33 Reduction of field data due to metal, range as %: Transponder and RF290R with ANT D6

Transponder		RF290R with ANT D6	
		Antenna on metal (metal plate)	Antenna flush-mounted in metal (all round 200 mm)
MDS D100 ¹⁾	Without metal	100	95
	On metal, distance 20 mm	65	60
MDS D124 ¹⁾	Without metal	100	95
	On metal, distance 25 mm	80	75
MDS D126 ¹⁾	Without metal	100	95
	On metal, distance 25 mm	65	60
MDS D139 ¹⁾	Without metal	100	90
	On metal, distance 30 mm	80	70
MDS D160 ¹⁾	Without metal	100	90
	On metal, distance 25 mm	60	55
MDS D165	Without metal	100	95
	On metal, distance 20 mm	50	45
MDS D200 ¹⁾	Without metal	100	95
	On metal, distance 20 mm	65	60
MDS D261	Without metal	100	95
	On metal, distance 20 mm	50	45
MDS D324 ¹⁾	Without metal	100	95
	On metal, distance 25 mm	75	70
MDS D339 ¹⁾	Without metal	100	90
	On metal, distance 30 mm	80	70
MDS D400 ¹⁾	Without metal	100	95
	On metal, distance 20 mm	60	55
MDS D424 ¹⁾	Without metal	100	95
	On metal, distance 25 mm	75	70
MDS D426 ¹⁾	Without metal	100	95
	On metal, distance 25 mm	65	60

¹⁾ Mounting the transponder on or in metal is only possible with the appropriate spacer or if there is adequate clearance to the metal.

Table 4- 34 Reduction of field data due to metal, range as %: Transponder and RF290R with ANT D10

Transponder		RF290R with ANT D10	
		Antenna on metal (metal plate)	Antenna flush-mounted in metal (all round 200 mm)
MDS D100 ¹⁾	Without metal	100	95
	On metal, distance 20 mm	50	40
MDS D124 ¹⁾	Without metal	100	90
	On metal, distance 25 mm	70	60
MDS D126 ¹⁾	Without metal	100	95
	On metal, distance 25 mm	65	60
MDS D139 ¹⁾	Without metal	100	90
	On metal, distance 30 mm	80	70
MDS D160 ¹⁾	Without metal	100	90
	On metal, distance 25 mm	60	55
MDS D165	Without metal	100	90
	On metal, distance 20 mm	40	30
MDS D200 ¹⁾	Without metal	100	95
	On metal, distance 20 mm	50	40
MDS D261	Without metal	100	90
	On metal, distance 20 mm	40	30
MDS D324 ¹⁾	Without metal	100	90
	On metal, distance 25 mm	70	60
MDS D339 ¹⁾	Without metal	100	90
	On metal, distance 30 mm	80	70
MDS D400 ¹⁾	Without metal	100	95
	On metal, distance 20 mm	50	40
MDS D424 ¹⁾	Without metal	100	90
	On metal, distance 25 mm	70	60
MDS D426 ¹⁾	Without metal	100	95
	On metal, distance 25 mm	70	65
MDS D524 ¹⁾	Without metal	100	90
	On metal, distance 25 mm	70	60
MDS D526 ¹⁾	Without metal	100	95
	On metal, distance 25 mm	70	65

¹⁾ Mounting the transponder on or in metal is only possible with the appropriate spacer or if there is adequate clearance to the metal.

4.3.5 Installation and connection of 2 to 6 antennas with one RF290R reader

If several antennas need to be operated on one reader, this can be achieved by using the antenna splitter or the antenna multiplexer RF260X.

Note that the antenna splitter is a purely passive device that splits the power at the input to two outputs and therefore halves it. This is possible both in PC mode (RS-232) and CM mode (RS-422). You can cascade the antenna splitters in such a way that up to 4 antennas can be connected at the same time.

The antenna multiplexer RF260X works only in PC mode (RS-232) in time division multiplex mode. This means that each antenna operates with full power for a certain time before the device moves on automatically to the next antenna. The antenna multiplexer normally operates in scan mode or buffered read mode which with suitable parameter assignment add the information about the antenna number to the reply of the transponder. You can operate up to six antennas on one reader via the multiplexer.

4.3.5.1 Installation options with the antenna splitter (2-4 antennas)

Possible configurations of the antennas

The antenna installations described here have been designed for reading smartlabels (transponders) on goods on conveyor belts, conveyor systems or pallets.

A prerequisite is that there are no magnetically conducting materials (e.g. metal) in the vicinity of the antenna or the label.

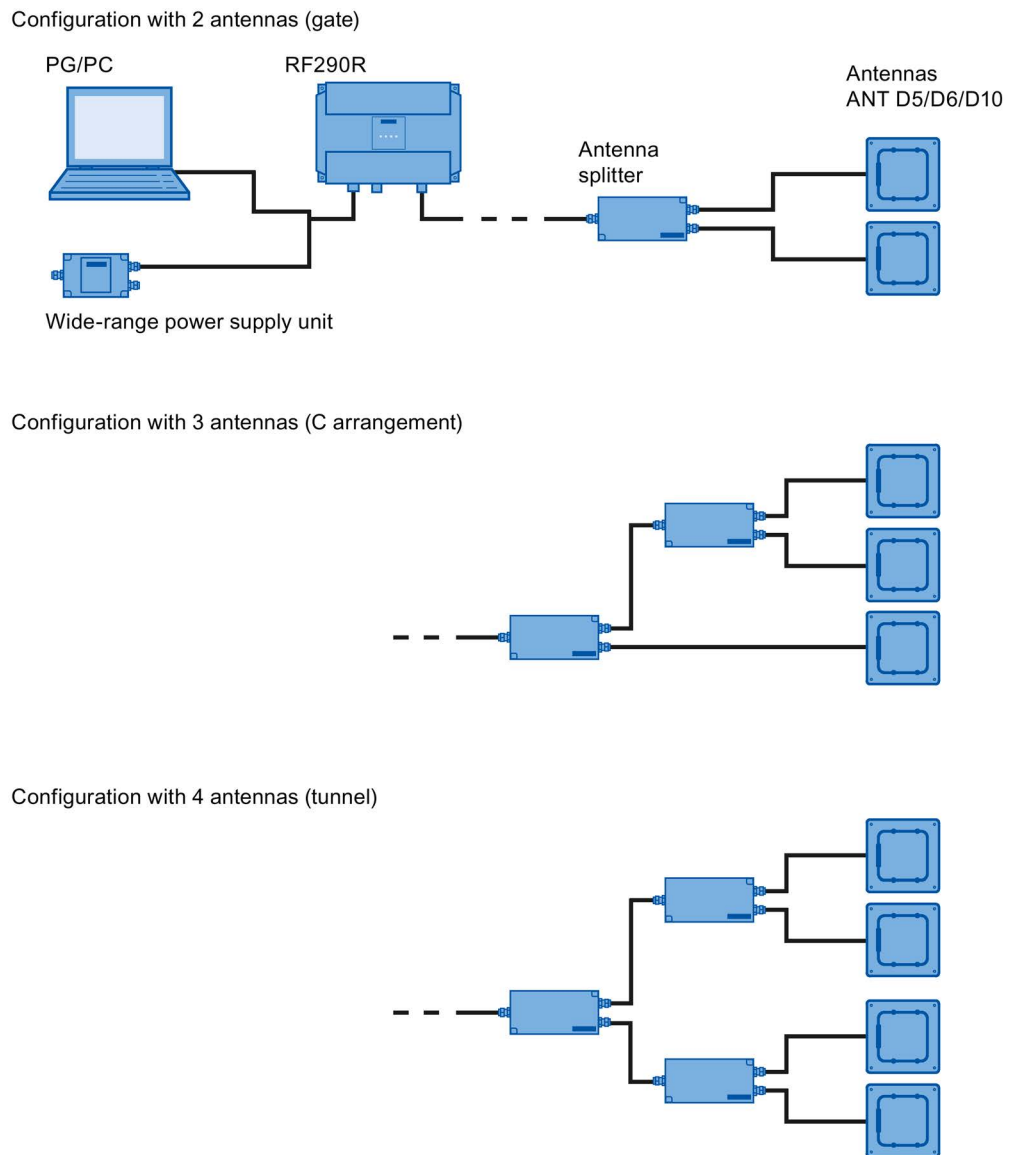

Figure 4-16 Possible configuration of RF290R with ANT D5/D6/D10

Installation examples

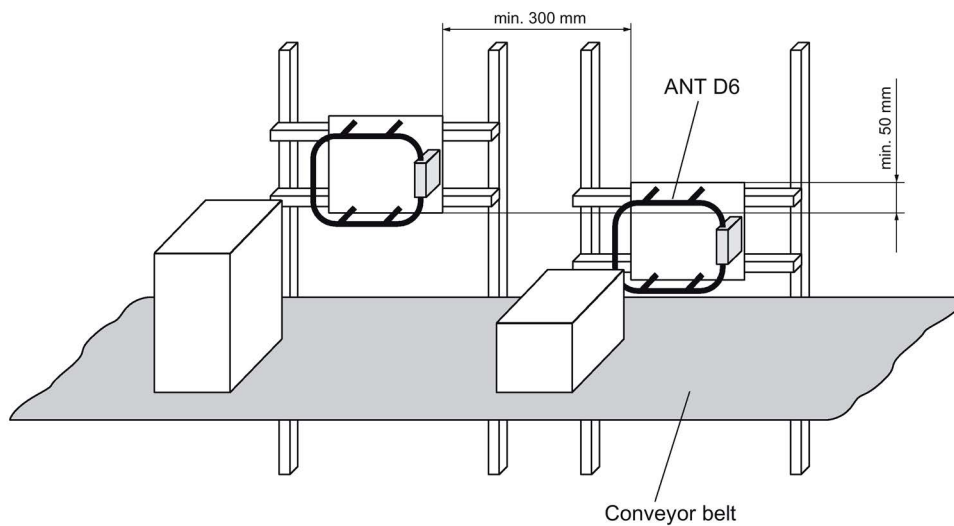

Figure 4-17 Installation example with 2 ANT D6 (portal)

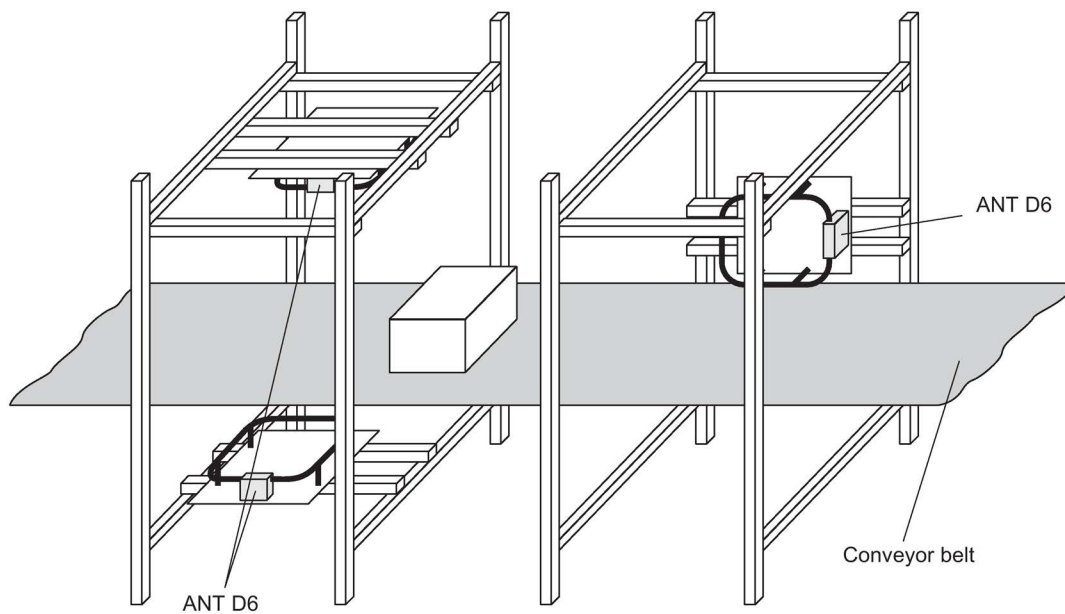

Figure 4-18 Installation example with ANT D6 (C arrangement)

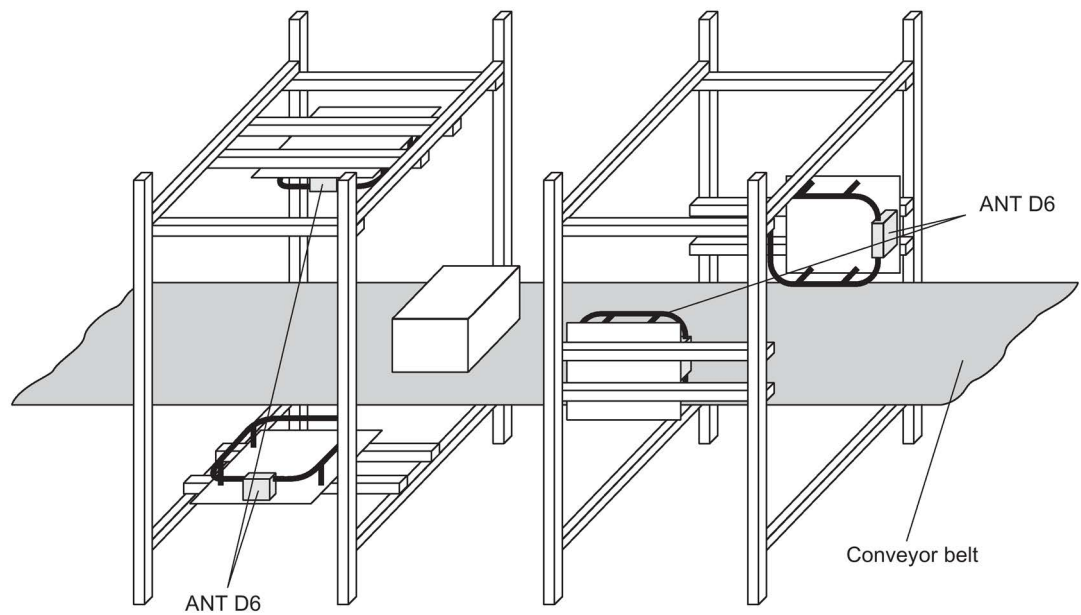

Figure 4-19 Installation example with ANT D6 (tunnel)

Note

The minimum spacings between the antennas for operation with only one reader may be less than the distances described because this configuration has the same phase.

4.3.5.2 Antenna installation

Configuring instructions

The antenna installation described below enables detection of transponders moving horizontally through the installation. Depending on the installation (antennas exactly opposite each other or offset in parallel), the label is aligned in parallel with the antennas or arbitrarily.

The size of the sensing range depends on the label alignment:

Note

Remember that the entire acquisition range of the antenna is larger than the transmission window in which the transponder is normally configured. This means there can be label alignments where even labels outside the transmission window will be identified. Labels aligned in parallel with the antennas, for example, can also be detected at larger distances beside or outside the antenna range.

For this reason, goods with labels must not be stored within a distance of up to 0.5 m from the installation. If this cannot be complied with, the antennas must be shielded.

To achieve three-dimensional detection of the labels in the sensing range, the following requirements must be met:

- The gate width must be less than or equal to 800 mm.
- The antenna size of the labels should be at least the size of an ISO card (85 mm x 54 mm).
- The distance from label to label must be greater than 100 mm. The distance from label to label can be reduced if the gate width is correspondingly reduced. This applies especially for distances under 50 mm.
- There should be no more than 16 labels within the sensing range of the antennas at the same time.
The number of labels can be increased if the gate width is correspondingly reduced and the maximum speed suitably adapted.
- The maximum speed of the labels must not exceed 1 m/s. (This depends on the number and alignment of the labels, the number of data blocks to be processed, the data protocol required and the label type).
- To the front and sides of the antenna, there must be a distance of more than 150 mm to metal parts.
- There must be no interference to the write/read device from other electrical equipment in the surrounding area.

Note

The RF290R reader is not capable of multitag operation in the CM mode.

Required components

For installation with

- 2 antennas (gate)
- 3 antennas (C arrangement)
- 4 antennas (tunnel)

the following components are required:

Table 4- 35 Components required for setting up with 2, 3 or 4 antennas

Number for installation with			Component	Article number
2 ant.	3 ant.	4 ant.		
1	1	1	Basic device: RF290R (↔ CM or PC)	RF290R: 6GT2821-0AC12 optionally: ASM 475: 6GT2002-0GA10 ASM 456: 6GT2002-0ED00 RF170C: 6GT2002-0HD00 RF180C: 6GT2002-0JD00 RF182C: 6GT2002-0JD10
2	3	4	Antenna ANT D5 / D6 / D10	optionally: ANT D5: 6GT2698-5AA10 ANT D6: 6GT2698-5AB00 ANT D10: 6GT2698-5AF00
2	3	4	With ANT D6 if required: cover	6GT2698-5AD00
1	2	3	Antenna splitter	6GT2603-0AC00
1	1	1	Wide-range power supply unit for SIMATIC RF systems (for PC mode only)	EU: 6GT2898-0AA00 UK: 6GT2898-0AA10 US: 6GT2898-0AA20
1	1	1	24 V connecting cable, length 5 m (for PC mode only)	6GT2491-1HH50
1	1	1	Connecting cable: RF290R ↔ PC or RF290R ↔ CM	6GT2891-4KH ... optionally: 6GT2891-4F ... 6GT2891-4EH ...

Installation information

The cables on the antennas and the antenna splitter are 3.3 m or 10.5 m long. The write/read device must be installed in the vicinity of the antennas. If there are greater distances between the write/read device and the antennas, the antenna cable can be increased by 7.2 m with the extension (6GT2691-0DH72). This results in shorter ranges.

Metal-free space

To guarantee perfect functioning of the individual installation versions, all larger metal parts in the vicinity of the antennas must be removed.

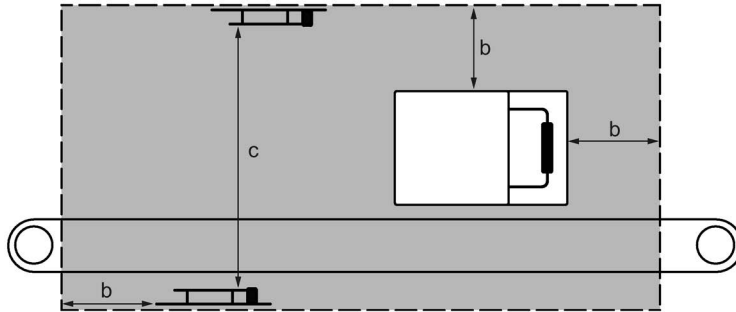
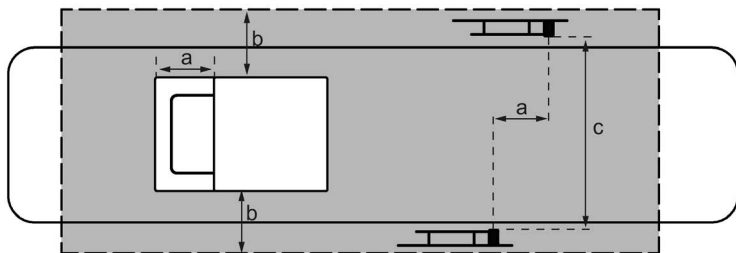

Figure 4-20 Metal-free space, side view (based on the example of a tunnel arrangement on a conveyor belt)



- a approx. half antenna length
- b min. 100 mm
- c max. 600 mm
- Metal-free space

Figure 4-21 Metal-free space, view from above (based on the example of a tunnel arrangement on a conveyor belt)

Metal in the vicinity of the antennas

If metal in the vicinity of the antennas cannot be avoided, the following must be noted:

- There must be a minimum allround gap of 100 mm between the antenna and metal. Serious loss of sensing range must be expected above 50 mm. There is no discernible influence at distances greater than 150 mm from the metal.
- The influence of the metal depends heavily on its size and shape. Thin metal rods have less influence on the magnetic field than large surfaces.
- Larger metal surfaces (edge length > 50 mm) in parallel with the antennas or labels result in a short-circuit of the magnetic lines of force. As a result, the labels cannot be read.
- Metal parts under the conveyor belt change the direction of the magnetic lines of force. Serious loss of sensing range must be expected as a result. Horizontally aligned labels cannot be read in such cases.

- **The metal parts must not form closed loops or circuits. If necessary, these must be electrically interrupted at one point.**
- The metal parts in the immediate vicinity of the antenna must be grounded in a mesh with a good HF connection.
- Since the write/read device is installed in a metal housing, and the antennas can couple into the cables to the write/read device, it must be installed at a distance of at least 500 mm from the antennas.

Notes on installing and laying the antenna cable

To suppress possible interference, an EMC hinged ferrite choke must be fitted to the antenna cables (as well as the antenna cable between the reader and the antenna splitter). The coaxial cable must be wound tightly at least four times through the EMC ring core. The maximum distance between the connecting plug for the reader or the antenna splitter and the ring core must be 100 mm.

The antenna cable must always be run vertically from the antennas. A minimum distance of 200 mm to the antennas must be observed as the cables continue. Otherwise, performance losses must be expected.

There must be a distance of at least 300 mm between antenna cables and parallel power cables.

Unrequired cable length must be secured in a bundle with a diameter of 100 to 150 mm.

If the standard antenna cable is too short, it can be increased by 7.20 m with the extension. Slight range losses must be expected here.

To achieve optimal read ranges, the antenna cable should not be shortened or lengthened.

4.3.5.3 Installation options with the antenna multiplexer (2-6 antennas)

You can operate up to six antennas on one reader via the multiplexer.

The data is processed sequentially.

Antenna switchover is performed in time-multiplex mode, so by connecting several antennas together, the processing time / activation time per antenna is lengthened accordingly.

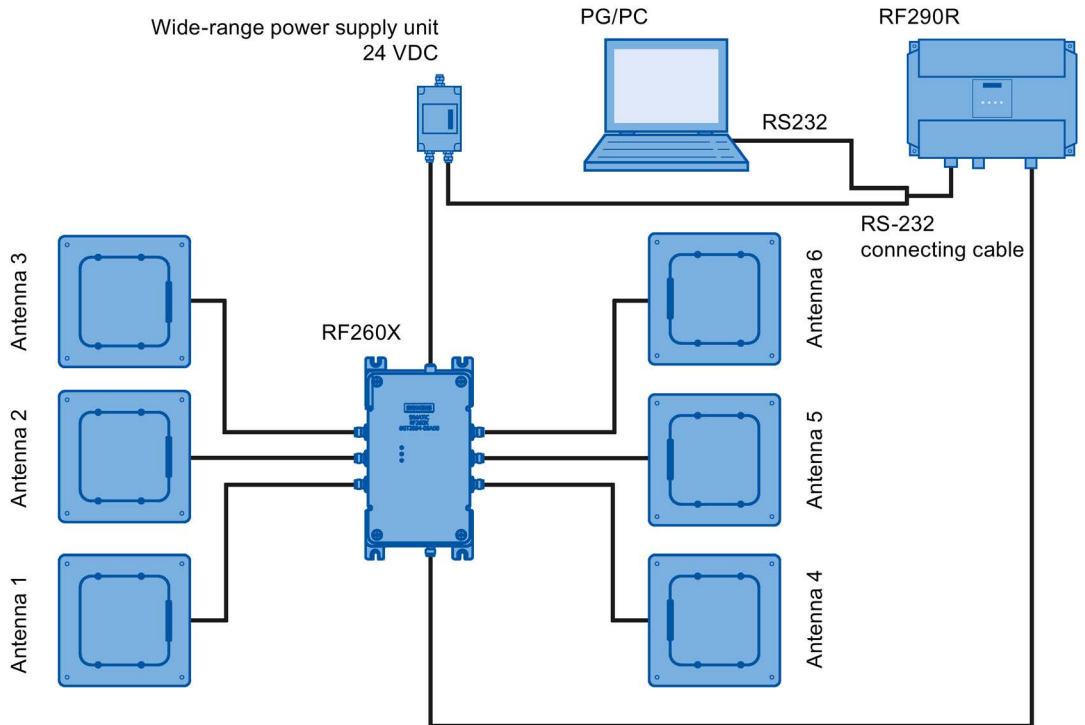

Figure 4-22 Configuration example of the antenna multiplexer with ANT D5

4.3.6 Chemical resistance of the reader and transponders

4.3.6.1 Readers

Overview of the readers and their housing materials

The following sections describe the chemical resistance of the various transponders. The chemical resistance depends on the housing materials used to manufacture the reader. The following table provides an overview of the housing materials used for the readers RF210R, RF220R, RF240R, RF250R, RF260R and RF280R:

Readers	Individual parts of the reader	Housing material of the reader
RF210R, RF220R	Sleeves	Brass (copper alloy) CuZn40Pb2
	Fiber-optic cable	Makrolon®2405
	Cap (antenna)	Thermocomp OF-1008-L-EM Valox 357
RF240R, RF250R, RF260R	Top shell and base plate	Polyamide 6.6 GF30; The chemical resistance of this plastic is listed in the section "Polyamide 6 and Polyamide 6.6 GF30 (Page 90)".
	Fiber-optic cable	Makrolon®2405
	Decorative foil ¹⁾	Autotex V200
RF280R	Top shell and base plate	Polyamide 12; The chemical resistance of this plastic is listed in the section "Polyamide 12 (Page 91)".
	Fiber-optic cable	Makrolon®2405
	Decorative foil ¹⁾	Autotex V200

¹⁾ Component irrelevant for resistance of the overall housing

Note

If you have any questions, please contact Siemens Support, see section "Service & Support (Page 377)".

Polyamide 6 and Polyamide 6.6 GF30

Table 4- 36 Chemical resistance - PA6 and PA6.6 GF30

Substance	Test conditions		Rating
	Concentration [%]	Temperature [°C]	
Mineral lubricants	-	-	++++
Aliphatic hydrocarbons	-	-	++++
Aromatic hydrocarbons	-	-	++++
Gasoline	-	-	++++
Weak mineral acids	-	-	+++
Strong mineral acids	-	-	○
Weak organic acids	-	-	++
Strong organic acids	-	-	○
Oxidizing acids	-	-	○
Weak alkaline solutions	-	-	++
Strong alkaline solutions	-	-	○
Trichloroethylene	-	-	++++
Perchloroethylene	-	-	++++
Acetone	-	-	++++
Alcohols	-	-	++++
Hot water (hydrolysis resistance)	-	-	++

Explanation of the rating	
++++	Resistant
+++	Practically resistant
++	Conditionally resistant
+	Less resistant
○	Not resistant

Polyamide 12

The resistance of the plastic housing to chemicals used in the automobile sector (e.g.: oils, greases, diesel fuel, gasoline, etc.) is not listed extra.

Table 4- 37 Chemical resistance - Polyamide 12

Substance	Test conditions		Rating
	Concentration [%]	Temperature [°C]	
Battery acid	30%	20 °C	++
Ammonia, gaseous	-	60 °C	++++
Ammonia, w.	conc.	60 °C	++++
	10%	60 °C	++++
Benzene	-	20 °C	++++
	-	60 °C	+++
Bleach solution (12.5% effective chlorine)	-	20 °C	++
Butane, gas, liquid	-	60 °C	++++
Butyl acetate (acetic acid butyl ester)	-	60 °C	++++
n(n)	-	20 °C	++++
	-	60 °C	+++
Calcium chloride, w.	-	20 °C	++++
	-	60 °C	+++
Calcium nitrate, w.	c. s.	20 °C	++++
	c. s.	60 °C	+++
Chlorine	-	20 °C	○
Chrome baths, tech.	-	20 °C	○
Iron salts, w.	c. s.	60 °C	++++
Acetic acid, w.	50%	20 °C	○
Ethyl alcohol, w., undenaturated	95%	20 °C	++++
	95%	60 °C	+++
	50%	60 °C	++++
Formaldehyde, w.	30%	20 °C	+++
	10%	20 °C	++++
	10%	60 °C	+++
Formalin	-	20 °C	+++
Glycerine	-	60 °C	++++
Isopropyl alcohol	-	20 °C	++++
	-	60 °C	+++
Potassium hydroxide, w.	50%	60 °C	++++
Lysol	-	20 °C	++
Magnesium salts, w.	c. s.	60 °C	++++
Methyl alcohol, w.	50%	60 °C	++++
Lactic acid, w.	50%	20 °C	++
	10%	20 °C	+++

Substance	Test conditions		Rating
	Concentration [%]	Temperature [°C]	
	10%	60 °C	++
Sodium carbonate, w. (soda)	c. s.	60 °C	++++
Sodium chloride, w.	c. s.	60 °C	++++
Sodium hydroxide	-	60 °C	++++
Nickel salts, w.	c. s.	60 °C	++++
Nitrobenzene	-	20 °C	+++
	-	60 °C	++
Phosphoric acid	10%	20 °C	+
Propane	-	60 °C	++++
Mercury	-	60 °C	++++
Nitric acid	10%	20 °C	+
Hydrochloric acid	10%	20 °C	+
Sulfur dioxide	low	60 °C	++++
Sulfuric acid	25%	20 °C	++
	10%	20 °C	+++
Hydrogen sulfide	low	60 °C	++++
Carbon tetrachloride	-	60 °C	++++
Toluene	-	20 °C	++++
	-	60 °C	+++
Detergent	high	60 °C	++++
Plasticizer	-	60 °C	++++

Explanation of the rating	
++++	Resistant
+++	Practically resistant
++	Conditionally resistant
+	Less resistant
o	Not resistant
w.	Water solution
c. s.	Cold saturated

4.3.6.2 Transponder

Overview of the transponders and their housing materials

The following sections describe the resistance to chemicals of the various transponders. Resistance to chemicals depends on the housing material used to manufacture the transponders.

The following table provides an overview of the housing materials of the transponders:

Table 4- 38 Overview of the housing materials of the transponders

Housing material	Transponder
Polyphenylene sulfide (PPS)	MDS D117 MDS D124 (6GT2600-0AC10) MDS D139 MDS D160 MDS D339 MDS D423
Polycarbonate (PC)	MDS D100 (6GT2600-0AD10)
Polyvinyl chloride (PVC)	MDS D100 (6GT2600-0AD00-0AX0) MDS D200 MDS D400
Epoxy resin	MDS D124 (6GT2600-0AC00) MDS D324 MDS D421 MDS D424 MDS D460 MDS D521 MDS D524
PA6	MDS D127
PA6.6 GF30	MDS D126 MDS D422 MDS D425 MDS D426 MDS D428 MDS D522 MDS D526 MDS D528

Note

Chemical substances not listed

The following sections describe the resistance of the various transponders to specific substances. If you require information about chemical substances that are not listed, contact Customer Support.

Polyphenylene sulfide (PPS)

The data memory has special chemical resistance to solutions up to a temperature of 200 °C. A reduction in the mechanical properties has been observed in aqueous solutions of hydrochloric acid (HCl) and nitric acid (HNO3) at 80 °C. The plastic housings are resistant to all types of fuel including methanol.

Table 4- 39 Chemical resistance - polyphenylene sulfide (PPS)

Substance	Test conditions		Rating
	Concentration [%]	Temperature [°C]	
Acetone	-	55 °C	++++
n-Butanol (butyl alcohol)	-	80 °C	++++
Butanone-2 (methyl ethyl ketone)	-	60 °C	++++
n-Butyl acetate	-	80 °C	++++
Brake fluid	-	80 °C	++++
Calcium chloride (saturated)	-	80 °C	++++
Diesel fuel	-	80 °C	++++
Diethyl ether	-	23 °C	++++
Frigen 113	-	23 °C	++++
Anti-freeze	-	120 °C	++++
Kerosene	-	60 °C	++++
Methanol	-	60 °C	++++
Engine oil	-	80 °C	++++
Sodium chloride (saturated)	-	80 °C	++++
Sodium hydroxide	30%	80 °C	++++
Sodium hypochlorite (30 or 180 days)	5%	80 °C	++
	5%	80 °C	-
Sodium hydroxide solution	30%	90 °C	++++
Nitric acid	10%	23 °C	++++
Hydrochloric acid	10%	80 °C	-
Sulfuric acid	10%	23 °C	++++
	10%	80 °C	++
	30%	23 °C	++++
Tested fuels	-	80 °C	++++

Substance	Test conditions		Rating
	Concentration [%]	Temperature [°C]	
FAM testing fluid acc. to DIN 51 604-A Toluene	-	80 °C	++
1, 1, 1-Trichloroethane Xylene	-	80 °C	++++
Zinc chloride (saturated)	-	80 °C	++
	-	75 °C	++++

Explanation of the rating	
++++	Resistant
+++	Practically resistant
++	Conditionally resistant
+	Less resistant
○	Not resistant

Polycarbonate (PC)

Table 4- 40 Chemical resistance - polycarbonate (PPS)

Substance	Test conditions		Rating
	Concentration [%]	Temperature [°C]	
Mineral lubricants	-	-	++
Aliphatic hydrocarbons	-	-	++++
Aromatic hydrocarbons	-	-	○
Gasoline	-	-	○
Weak mineral acids	-	-	++++
Strong mineral acids	-	-	++
Weak organic acids	-	-	++++
Strong organic acids	-	-	++
Oxidizing acids	-	-	○
Weak alkaline solutions	-	-	○
Strong alkaline solutions	-	-	○
Trichloroethylene	-	-	○
Perchloroethylene	-	-	○
Acetone	-	-	○
Alcohols	-	-	++
Hot water (hydrolysis resistance)	-	-	○

Explanation of the rating	
++++	Resistant
+++	Practically resistant
++	Conditionally resistant
+	Less resistant
○	Not resistant

Polyvinyl chloride (PVC)

Table 4- 41 Chemical resistance - polyvinyl chloride (PVC)

Substance	Test conditions		Rating
	Concentration [%]	Temperature [°C]	
Salt water	5%	-	++++
Sugared water	10%	-	++++
Acetic acid, w.	5%	-	++++
Sodium carbonate, w.	5%	-	++++
Ethyl alcohol, w.	60%	-	++++
Ethylene glycol	50%	-	++++
Fuel B (acc. to ISO 1817)	-	-	++++
Human sweat	-	-	++++

Explanation of the rating	
++++	Resistant
++++	Practically resistant
++	Conditionally resistant
+	Less resistant
○	Not resistant

Epoxy resin

Table 4- 42 Chemical Resistance - epoxy resin

Substance	Test conditions		Rating
	Concentration [%]	Temperature [°C]	
Allyl chloride	-	20 °C	++++
Formic acid	50%	20 °C	++++
	100%	20 °C	++
Ammonia, gaseous	-	20 °C	++++
Ammonia, liquid, water-free	-	20 °C	○
Ammonium hydroxide	10%	20 °C	++++
Ethanol	-	40 °C	++++
	-	60 °C	++++
Ethyl acrylate	-	20 °C	++++
Ethyl glycol	-	60 °C	++++
Gasoline, aroma-free	-	20 °C	++++
Gasoline, containing benzene	-	20 °C	++++
Benzoates (Na-, Ca- among others)	-	40 °C	++++
Benzoic acid	-	20 °C	++++

Substance	Test conditions		Rating
	Concentration [%]	Temperature [°C]	
Benzene	-	20 °C	++++
Borax	-	60 °C	++++
Boric acid	-	20 °C	++++
Bromine, liquid	-	20 °C	○
Bromides (K-, Na- among others)	-	60 °C	++++
Bromoform	100%	20 °C	++++
Bromine water	-	20 °C	○
Butadien (1.3-)	-	20 °C	++++
Butane, gaseous	-	20 °C	++++
Butanol	-	20 °C	○
Butyric acid	100%	20 °C	++
Carbonates (ammonium-, Na- among others)	-	60 °C	++++
Chlorine, liquid	-	20 °C	○
Chlorine, gaseous, dry	100%	20 °C	○
Chlorobenzene	-	20 °C	++++
Chlorides (ammonium-, Na- among others)	-	60 °C	++++
Chloroform	-	20 °C	○
Chlorophyll	-	20 °C	++++
Chlorosulfuric acid	100%	20 °C	○
Chlorine water (saturated solution)	-	20 °C	++
Chromates (K-, Na- among others)	Up to 50 %	40 °C	++++
Chromic acid	Up to 30 %	20 °C	○
Chromosulfuric acid	-	20 °C	○
Citric acid	-	20 °C	++++
Cyanamide	-	20 °C	++++
Cyanides (K-, Na- among others)	-	60 °C	++++
Dextrin, w.	-	60 °C	++++
Diethyl ether	-	20 °C	++++
Diethylene glycol	-	60 °C	++++
Dimethyl ether	-	20 °C	++++
Dioxane	-	20 °C	○
Developer	-	40 °C	++++
Acetic acid	100%	20 °C	++
Ethanol	-	60 °C	++++
Fixing bath	-	40 °C	++++
Fluorides (ammonium-, K-, Na- among others)	-	40 °C	++++
Hydrofluoric acid	Up to 40 %	20 °C	++++
Formaldehyde	50%	20 °C	++++
Formamide	100%	20 °C	++++

Substance	Test conditions		Rating
	Concentration [%]	Temperature [°C]	
Gluconic acid	-	20 °C	++++
Glycerine	-	60 °C	++++
Glycol	-	60 °C	++++
Urine	-	20 °C	++++
Uric acid	-	20 °C	++++
Hydroxides (ammonium...)	10%	20 °C	++++
Hydroxides (Na-, K-)	40%	20 °C	++++
Hydroxides (alkaline earth metal)	-	60 °C	++++
Hypochlorites (K-, Na- among others)	-	60 °C	++++
Iodides (K-, Na- among others)	-	60 °C	++++
Silicic acid	-	60 °C	++++
Cresol	Up to 90 %	20 °C	○
Methanol	100%	40 °C	++++
Methylene chloride	-	20 °C	○
Lactic acid	100%	20 °C	++
Mineral oils	-	40 °C	++++
Nitrates (ammonium..., K- among others)	-	60 °C	++++
Nitroglycerin	-	20 °C	○
Oxalic acid	-	20 °C	++++
Phenol	1%	20 °C	++++
Phosphates (ammonium..., Na- among others)		60 °C	++++
Phosphoric acid	50%	60 °C	++++
	85%	20 °C	++++
Propanol	-	20 °C	++++
Nitric acid	25%	20 °C	○
Hydrochloric acid	10%	20 °C	○
Brine	-	60 °C	○
Sulfur dioxide	100%	20 °C	++
Carbon disulfide	100%	20 °C	○
Sulfuric acid	40%	20 °C	○
Sulfurous acid	-	20 °C	++
Soap solution	-	60 °C	++++
Sulphates (ammonium..., Na- among others)	-	60 °C	++++
Sulfites (ammonium..., Na- among others)	-	60 °C	○
Tar, aroma-free	-	60 °C	++++
Turpentine	-	20 °C	++++
Trichloroethylene	-	20 °C	○

Substance	Test conditions		Rating
	Concentration [%]	Temperature [°C]	
Hydrogen peroxide	30%	20 °C	++++
Tartaric acid	-	20 °C	++++

Explanation of the rating	
++++	Resistant
+++	Practically resistant
++	Conditionally resistant
+	Less resistant
○	Not resistant

Polyamide 6 and Polyamide 6.6 GF30

Table 4- 43 Chemical resistance - PA6 and PA6.6 GF30

Substance	Test conditions		Rating
	Concentration [%]	Temperature [°C]	
Mineral lubricants	-	-	++++
Aliphatic hydrocarbons	-	-	++++
Aromatic hydrocarbons	-	-	++++
Gasoline	-	-	++++
Weak mineral acids	-	-	+++
Strong mineral acids	-	-	○
Weak organic acids	-	-	++
Strong organic acids	-	-	○
Oxidizing acids	-	-	○
Weak alkaline solutions	-	-	++
Strong alkaline solutions	-	-	○
Trichloroethylene	-	-	++++
Perchloroethylene	-	-	++++
Acetone	-	-	++++
Alcohols	-	-	++++
Hot water (hydrolysis resistance)	-	-	++

Explanation of the rating	
++++	Resistant
+++	Practically resistant
++	Conditionally resistant
+	Less resistant
○	Not resistant

4.4 Further information

Further information on "Fundamentals of application planning" and "EMC" can be found in RF300 system manual (<https://support.industry.siemens.com/cs/ww/en/view/21738946>).

NOTICE
Pulling and plugging readers
Pull or plug the reader only when the power supply is turned off
If this is not observed, under certain conditions, the reader will not start up correctly and communication with a transponder will not be possible.

Note**IO-Link variants of the RF200 readers**

The IO-Link variants of the readers are not included in the system manual. You will find these in the "SIMATIC RF200 IO-Link

(<https://support.industry.siemens.com/cs/ww/en/view/60641859>)" operating instructions.

5.1 SIMATIC RF210R

5.1.1 Features

SIMATIC RF210R	Characteristics	
	Design	<ul style="list-style-type: none"> ① RS422 interface ② Status display
	Application	Identification tasks on assembly lines in harsh industrial environments

5.1.2 RF210R ordering data

	Article number
RF210R with RS422 interface (3964R)	6GT2821-1AC10



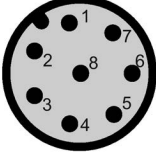

5.1.3 Pin assignment RF210R with RS422 interface

Pin	Pin Device end 8-pin M12	Assignment
	1	+ 24 V
	2	- Transmit
	3	0 V
	4	+ Transmit
	5	+ Receive
	6	- Receive
	7	Unassigned
	8	Ground (shield)

5.1.4 LED operating display

The operational statuses of the reader are displayed by the LEDs. The LED can adopt the colors green, red or yellow and the statuses off , on , flashing :

Table 5- 1 LED operating display on the reader

LED	Meaning
	The reader is turned off.
	Operating voltage present, reader not initialized or antenna switched off
	Operating voltage present, reader initialized and antenna switched on
	<ul style="list-style-type: none"> Operating mode "with presence": Transponder present Operating mode "without presence": Transponder present and command currently being executed
	There is an error. The number of flashes provides information about the current error. You can find more information on error messages in the section "Error codes of the RF200 readers (Page 329)". The optical error display is only reset if the corresponding reset parameter ("option_1 = 2") is set (see product information "SIMATIC RF200 Command Set (https://support.industry.siemens.com/cs/ww/en/view/44864850)").

5.1.5 Minimum distance between RF210R readers

RF210R side by side

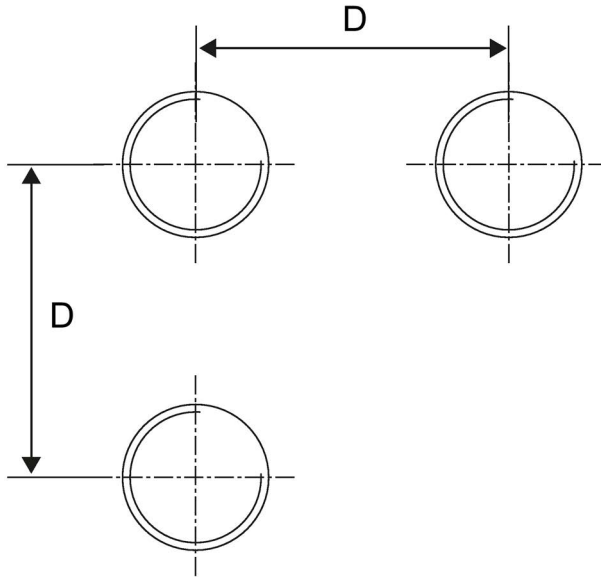

$D \geq 60 \text{ mm}$

Figure 5-1 Minimum distance between RF210R readers

RF210R face to face

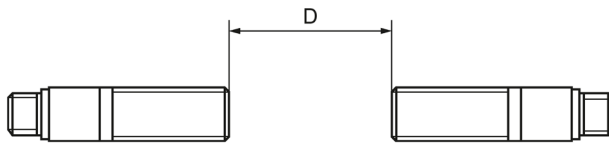

$D \geq 100 \text{ mm}$

Figure 5-2 Face-to-face distance between two RF210Rs

5.1.6 Technical specifications of the RF210R reader

Table 5- 2 Technical specifications of the RF210R reader

6GT2821-1AC10	
Product type designation	SIMATIC RF210R
Radio frequencies	
Operating frequency, rated value	13.56 MHz
Electrical data	
Maximum range	20 mm
Maximum data transmission speed reader ↔ transponder	ISO tags
• Read	• approx. 1500 bytes/s
• Write	• approx. 1500 bytes/s
Typical transmission time for user data per byte	
• for write access	• 0.6 ms
• for read access	• 0.6 ms
Transmission speed	19.2, 57.6, 115.2 kBd
Read/write distances of the reader	see section "Field data (Page 39)"
MTBF (Mean Time Between Failures)	505 years
Interfaces	
Electrical connector design	M12, 8-pin
Standard for interfaces for communication	RS-422
Antenna	integrated
Mechanical specifications	
Housing	
• Material	• Brass, nickel-plated
• Color	• Silver
Recommended distance to metal	0 mm
Supply voltage, current consumption, power loss	
Supply voltage	24 VDC
Typical current consumption	50 mA
Permitted ambient conditions	
Ambient temperature	
• During operation	• -20 ... +70 °C

6GT2821-1AC10	
• During transportation and storage	• -25 ... +85 °C
Degree of protection to EN 60529	IP67
Shock-resistant to EN 60721-3-7, Class 7 M3	500 m/s ²
Vibration-resistant to EN 60721-3-7, Class 7 M3	200 m/s ²
Torsion and bending load	Not permitted
Design, dimensions and weight	
Dimensions (Ø x thread x L)	M18 x 1 x 83 mm
Weight	65 g
Type of mounting	2x nuts M18 x 1
Cable length for RS-422 interface, maximum	1000 m
LED display design	3-color LED (operating voltage, presence, error)

5.1.7 Approvals

FCC information

Siemens SIMATIC RF210R (MLFB 6GT2821-1AC10) FCC ID NXW-RF210R

This device complies with part 15 of the FCC rules. Operation is subject to the following two conditions:

- (1) This device may not cause harmful interference, and
- (2) this device must accept any interference received, including interference that may cause undesired operation.

Caution

Any changes or modifications not expressly approved by the party responsible for compliance could void the user's authority to operate the equipment.

Note

This equipment has been tested and found to comply with the limits for a Class A digital device, pursuant to part 15 of the FCC Rules.

These limits are designed to provide reasonable protection against harmful interference when the equipment is operated in a commercial environment. This equipment generates, uses, and can radiate radio frequency energy and, if not installed and used in accordance with the instruction manual, may cause harmful interference to radio communications. Operation of this equipment in a residential area is likely to cause harmful interference in which case the user will be required to correct the interference at his own expense.

IC information

This device complies with Industry Canada licence-exempt RSS standard(s). Operation is subject to the following two conditions:

- (1) This device may not cause interference, and
- (2) this device must accept any interference, including interference that may cause undesired operation of the device.

Le présent appareil est conforme aux CNR d'Industrie Canada applicables aux appareils radio exempts de licence. L'exploitation est autorisée aux deux conditions suivantes :

- (1) L'appareil ne doit pas produire de brouillage, et
- (2) l'utilisateur de l'appareil doit accepter tout brouillage radioélectrique subi, même si le brouillage est susceptible d'en compromettre le fonctionnement.

5.1.8 Dimension drawing

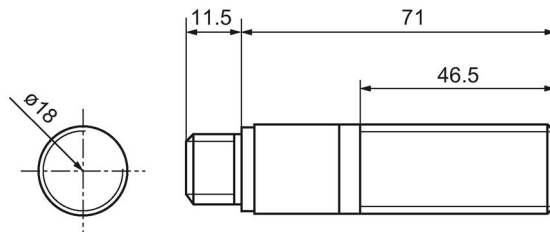



Figure 5-3 RF210R dimension drawing

Dimensions in mm

5.2 SIMATIC RF210M

5.2.1 Features

SIMATIC RF210M	Characteristics	
	Design	① RS422 interface ② Status display
	Application	Reader for hand work and rework places, picking, track and trace, tool Ident

5.2.2 Ordering data RF210M

	Article number
RF210M with RS-422 interface (3964R)	6GT2823-0AA00

5.2.3 Installing the RF210M reader

The following figure shows the completely mounted reader. Note that you can mount the suspension bracket at two different points ①. If you do not mount the handle, we recommend that you close the opening ② with the protective cap.



- ① Holes for mounting the suspension bracket
- ② Thread for mounting the handle

Figure 5-4 Installing the reader



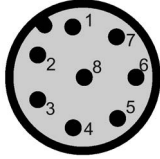

5.2.4 Pin assignment RF210M with RS-422 interface

Pin	Pin Device end 8-pin M12	Assignment
	1	+ 24 V
	2	- Transmit
	3	0 V
	4	+ Transmit
	5	+ Receive
	6	- Receive
	7	Unassigned
	8	Ground (shield)

5.2.5 LED operating display

The operational statuses of the reader are displayed by the LEDs. The LED can adopt the colors green, red or yellow and the statuses off , on , flashing :

Table 5- 3 LED operating display on the reader

LED	Meaning
	The reader is turned off.
	Operating voltage present, reader not initialized or antenna switched off
	Operating voltage present, reader initialized and antenna switched on
	<ul style="list-style-type: none"> Operating mode "with presence": Transponder present Operating mode "without presence": Transponder present and command currently being executed
	There is an error. The number of flashes provides information about the current error. You can find more information on error messages in the section "Error codes of the RF200 readers (Page 329)". The optical error display is only reset if the corresponding reset parameter ("option_1 = 2") is set (see product information "SIMATIC RF200 Command Set (https://support.industry.siemens.com/cs/ww/en/view/44864850)").

5.2.6 Technical specifications of the RF210M reader

Table 5- 4 Technical specifications of the RF210M reader

6GT2823-0AA00	
Product type designation	SIMATIC RF210M
Radio frequencies	
Operating frequency, rated value	13.56 MHz
Electrical data	
Maximum range	20 mm
Maximum data transmission speed reader ↔ transponder	ISO tags
• Read	• approx. 1500 bytes/s
• Write	• approx. 1500 bytes/s
Typical transmission time for user data per byte	
• for write access	• 0.6 ms
• for read access	• 0.6 ms
Transmission speed	19.2, 57.6, 115.2 kBd
Read/write distances of the reader	see section "Field data (Page 39)"
MTBF (Mean Time Between Failures)	505 years
Interfaces	
Electrical connector design	M12, 8-pin
Standard for interfaces for communication	RS-422
Antenna	integrated
Mechanical specifications	
Housing	
• Material	• POM
• Color	• Black
Supply voltage, current consumption, power loss	
Supply voltage	24 VDC
Typical current consumption	50 mA
Permitted ambient conditions	
Ambient temperature	
• During operation	• -20 ... +50 °C
• During transportation and storage	• -25 ... +60 °C

6GT2823-0AA00	
Degree of protection to EN 60529	IP54
Shock-resistant to EN 60721-3-7, Class 7 M3	500 m/s ²
Vibration-resistant to EN 60721-3-7, Class 7 M3	200 m/s ²
Design, dimensions and weight	
Dimensions	
• Reader with handle (L x W x H)	195 x 26 x 140 mm
• Reader without handle (L x W x H)	195 x 26 x 46 mm
• Spiral connecting cable (L)	2 m maximum working length 3.5 m
Weight	460 g
Type of mounting	Bracket for for hanging up
Cable length for RS-422 interface, maximum	1000 m
LED display design	3-color LED (operating voltage, presence, error)

5.2.7 Approvals

FCC information

Siemens SIMATIC RF210R (MLFB 6GT2821-1AC10) FCC ID NXW-RF210R

This device complies with part 15 of the FCC rules. Operation is subject to the following two conditions:

- (1) This device may not cause harmful interference, and
- (2) this device must accept any interference received, including interference that may cause undesired operation.

Caution

Any changes or modifications not expressly approved by the party responsible for compliance could void the user's authority to operate the equipment.

Note

This equipment has been tested and found to comply with the limits for a Class A digital device, pursuant to part 15 of the FCC Rules.

These limits are designed to provide reasonable protection against harmful interference when the equipment is operated in a commercial environment. This equipment generates, uses, and can radiate radio frequency energy and, if not installed and used in accordance with the instruction manual, may cause harmful interference to radio communications. Operation of this equipment in a residential area is likely to cause harmful interference in which case the user will be required to correct the interference at his own expense.

IC information

This device complies with Industry Canada licence-exempt RSS standard(s). Operation is subject to the following two conditions:

- (1) This device may not cause interference, and
- (2) this device must accept any interference, including interference that may cause undesired operation of the device.

Le présent appareil est conforme aux CNR d'Industrie Canada applicables aux appareils radio exempts de licence. L'exploitation est autorisée aux deux conditions suivantes :

- (1) L'appareil ne doit pas produire de brouillage, et
- (2) l'utilisateur de l'appareil doit accepter tout brouillage radioélectrique subi, même si le brouillage est susceptible d'en compromettre le fonctionnement.

5.2.8 Dimension drawing

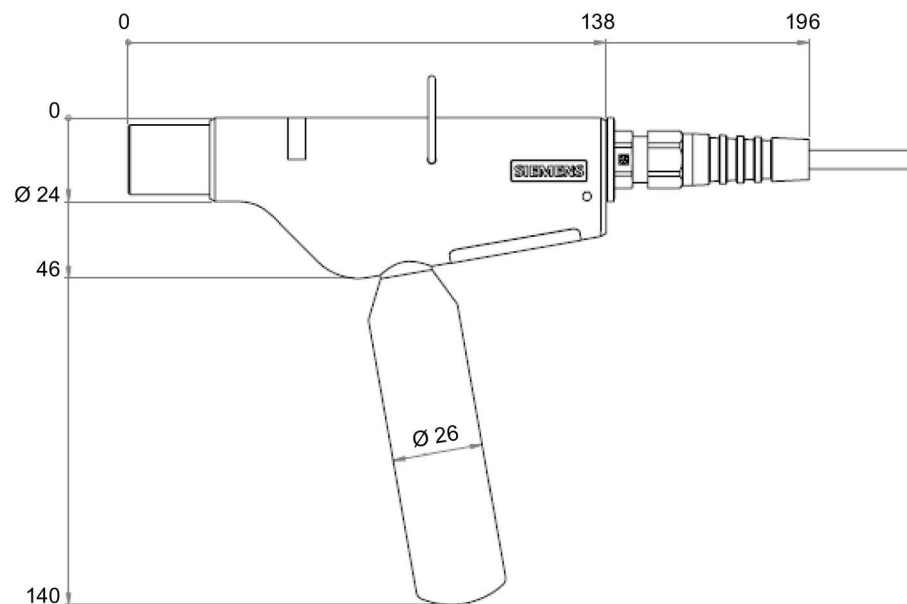



Figure 5-5 Dimension drawing RF210M

All dimensions in mm, tolerances ± 1 mm

5.3 SIMATIC RF220R

5.3.1 Features

SIMATIC RF220R	Characteristics	
	Design	<ul style="list-style-type: none"> ① RS422 interface ② Status display
	Application	Identification tasks on assembly lines in harsh industrial environments

5.3.2 RF220R ordering data

	Article number
RF220R with RS-422 interface (3964R)	6GT2821-2AC10



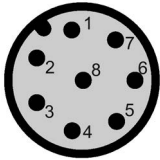

5.3.3 RF220R pin assignment with RS422 interface

Pin	Pin Device end 8- pin M12	Assignment
	1	+ 24 V
	2	- Transmit
	3	0 V
	4	+ Transmit
	5	+ Receive
	6	- Receive
	7	Unassigned
	8	Ground (shield)

5.3.4 LED operating display

The operational statuses of the reader are displayed by the LEDs. The LED can adopt the colors green, red or yellow and the statuses off , on , flashing :

Table 5- 5 LED operating display on the reader

LED	Meaning
	The reader is turned off.
	Operating voltage present, reader not initialized or antenna switched off
	Operating voltage present, reader initialized and antenna switched on
	<ul style="list-style-type: none"> Operating mode "with presence": Transponder present Operating mode "without presence": Transponder present and command currently being executed
	There is an error. The number of flashes provides information about the current error. You can find more information on error messages in the section "Error codes of the RF200 readers (Page 329)". The optical error display is only reset if the corresponding reset parameter ("option_1 = 2") is set (see product information "SIMATIC RF200 Command Set (https://support.industry.siemens.com/cs/ww/en/view/44864850)").

5.3.5 Minimum distance between RF220R readers

RF220R side by side

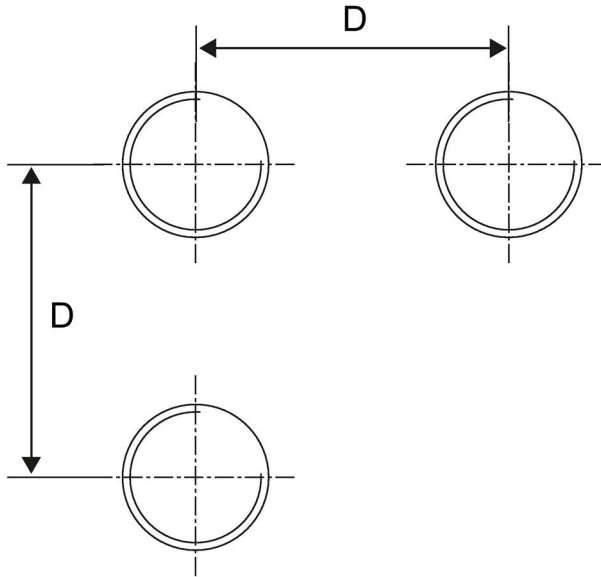

$D \geq 100 \text{ mm}$

Figure 5-6 Minimum distance between RF220R readers

RF220R face to face

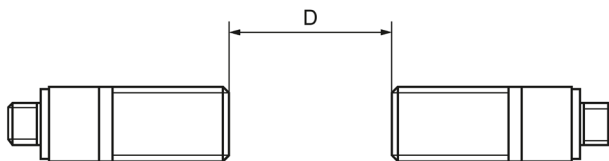

$D \geq 150 \text{ mm}$

Figure 5-7 Face-to-face distance between two RF220Rs

5.3.6 Technical specifications of the RF220R reader

Table 5- 6 Technical specifications of the RF220R reader

6GT2821-2AC10	
Product type designation	SIMATIC RF220R
Radio frequencies	
Operating frequency, rated value	13.56 MHz
Electrical data	
Maximum range	35 mm
Maximum data transmission speed reader ↔ transponder	ISO tags
• Read	• approx. 1500 bytes/s
• Write	• approx. 1500 bytes/s
Typical transmission time for user data per byte	
• for write access	• 0.6 ms
• for read access	• 0.6 ms
Transmission speed	19.2, 57.6, 115.2 kBd
Read/write distances of the reader	see section "Field data (Page 39)"
MTBF (Mean Time Between Failures)	501 years
Interfaces	
Electrical connector design	M12, 8-pin
Standard for interfaces for communication	RS-422
Antenna	integrated
Mechanical specifications	
Housing	
• Material	• Brass, nickel-plated
• Color	• Silver
Recommended distance to metal	0 mm
Supply voltage, current consumption, power loss	
Supply voltage	24 VDC
Typical current consumption	50 mA
Permitted ambient conditions	
Ambient temperature	
• During operation	• -20 ... +70 °C

6GT2821-2AC10	
• During transportation and storage	• -25 ... +85 °C
Degree of protection to EN 60529	IP67
Shock-resistant to EN 60721-3-7, Class 7 M3	500 m/s ²
Vibration-resistant to EN 60721-3-7, Class 7 M3	200 m/s ²
Torsion and bending load	Not permitted
Design, dimensions and weight	
Dimensions (Ø x thread x L)	M30 x 1.5 x 83 mm
Weight	140 g
Type of mounting	2x nuts M30 x 1.5
Cable length for RS-422 interface, maximum	1000 m
LED display design	3-color LED (operating voltage, presence, error)

5.3.7 Approvals

FCC information

Siemens SIMATIC RF220R (MLFB 6GT2821-2AC10) FCC ID NXW-RF220R

This device complies with part 15 of the FCC rules. Operation is subject to the following two conditions:

- (1) This device may not cause harmful interference, and
- (2) this device must accept any interference received, including interference that may cause undesired operation.

Caution

Any changes or modifications not expressly approved by the party responsible for compliance could void the user's authority to operate the equipment.

Note

This equipment has been tested and found to comply with the limits for a Class A digital device, pursuant to part 15 of the FCC Rules.

These limits are designed to provide reasonable protection against harmful interference when the equipment is operated in a commercial environment. This equipment generates, uses, and can radiate radio frequency energy and, if not installed and used in accordance with the instruction manual, may cause harmful interference to radio communications. Operation of this equipment in a residential area is likely to cause harmful interference in which case the user will be required to correct the interference at his own expense.

IC information

This device complies with Industry Canada licence-exempt RSS standard(s). Operation is subject to the following two conditions:

- (1) This device may not cause interference, and
- (2) this device must accept any interference, including interference that may cause undesired operation of the device.

Le présent appareil est conforme aux CNR d'Industrie Canada applicables aux appareils radio exempts de licence. L'exploitation est autorisée aux deux conditions suivantes :

- (1) L'appareil ne doit pas produire de brouillage, et
- (2) l'utilisateur de l'appareil doit accepter tout brouillage radioélectrique subi, même si le brouillage est susceptible d'en compromettre le fonctionnement.

5.3.8 Dimension drawing

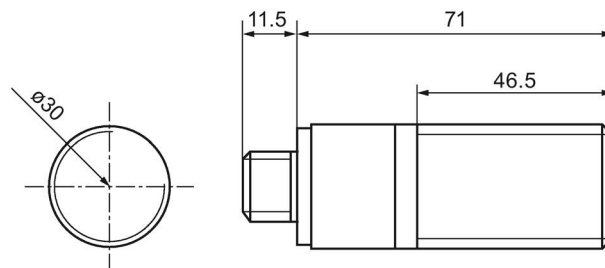



Figure 5-8 RF220R dimension drawing

Dimensions in mm

5.4 SIMATIC RF240R

5.4.1 Features

SIMATIC RF240R	Characteristics	
	Structure	① RS-422 or RS-232 interface ② Operating indicator
	Field of application	Identification tasks on assembly lines in harsh industrial environments

5.4.2 RF240R ordering data

	Article number
RF240R with RS-422 interface (3964R)	6GT2821-4AC10
RF240R with RS-232 interface (3964R)	6GT2821-4AC11
RF240R with RS-232 interface (ASCII)	6GT2821-4AC40



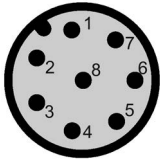

5.4.3 Pin assignment RF240R

Pin	Pin Device end 8- pin M12	Interface assignment	
		RS-422	RS-232
	1	+24 V	+24 V
	2	- Transmit	RXD
	3	0 V	0 V
	4	+ Transmit	TXD
	5	+ Receive	Unassigned
	6	- Receive	Unassigned
	7	Unassigned	Unassigned
	8	Ground (shield)	Ground (shield)

5.4.4 LED operating display

The operational statuses of the reader are displayed by the LEDs. The LED can adopt the colors green, red or yellow and the statuses off , on , flashing :

Table 5- 7 LED operating display on the reader

LED	Meaning
	The reader is turned off.
	Operating voltage present, reader not initialized or antenna switched off
	Operating voltage present, reader initialized and antenna switched on
	<ul style="list-style-type: none"> Operating mode "with presence": Transponder present Operating mode "without presence": Transponder present and command currently being executed
	There is an error. The number of flashes provides information about the current error. You can find more information on error messages in the section "Error codes of the RF200 readers (Page 329)". The optical error display is only reset if the corresponding reset parameter ("option_1 = 2") is set (see product information "SIMATIC RF200 Command Set (https://support.industry.siemens.com/cs/ww/en/view/44864850)").

5.4.5 Minimum distance between several RF240R readers

RF240R readers side by side

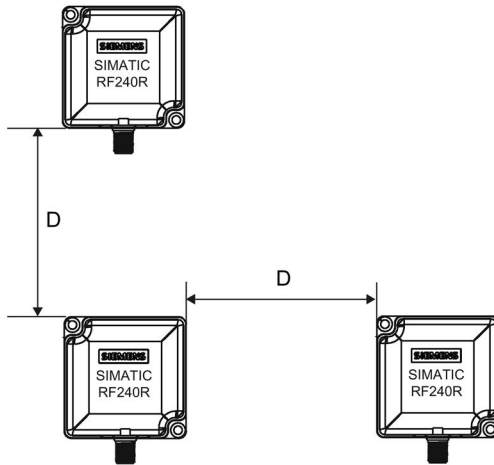

- D ≥ 120 mm (with 2 readers)
- D ≥ 200 mm (with more than 2 readers)

Figure 5-9 Minimum distance between several RF240R readers

RF240R face-to-face

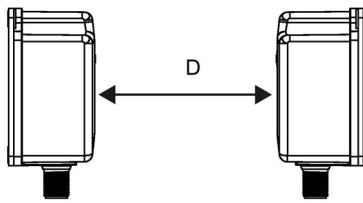

- D ≥ 400 mm

Figure 5-10 Face-of-face distance between two RF240R readers

5.4.6 Technical specifications of the RF240R reader

Table 5- 8 Technical specifications of the RF240R reader

	6GT2821-4AC10 6GT2821-4AC11 6GT2821-4AC40
Product type designation	SIMATIC RF240R
Radio frequencies	
Operating frequency, rated value	13.56 MHz
Electrical data	
Maximum range	65 mm
Maximum data transmission speed reader ↔ transponder	ISO tags
• Read	• approx. 1500 bytes/s
• Write	• approx. 1500 bytes/s
Typical transmission time for user data per byte	
• for write access	• 0.6 ms
• for read access	• 0.6 ms
Transmission speed	19.2, 57.6, 115.2 kBd
Read/write distances of the reader	see section "Field data (Page 39)"
MTBF (Mean Time Between Failures)	430 years
Interfaces	
Electrical connector design	M12, 8-pin
Standard for interfaces for communication	
• 6GT2821-4AC10	• RS-422 (3964R protocol)
• 6GT2821-4AC11	• RS-232 (3964R protocol)
• 6GT2821-4AC40	• RS-232 (ASCII protocol)
Antenna	integrated
Mechanical specifications	
Housing	
• Material	• Plastic PA 6.6
• Color	• Anthracite
Recommended distance to metal	0 mm

6GT2821-4AC10
6GT2821-4AC11
6GT2821-4AC40

Supply voltage, current consumption, power loss

Supply voltage	24 VDC
Typical current consumption	25 mA

Permitted ambient conditions

Ambient temperature

- | | |
|-------------------------------------|------------------|
| • During operation | • -20 ... +70 °C |
| • During transportation and storage | • -25 ... +85 °C |

Degree of protection to EN 60529	IP67
----------------------------------	------

Shock-resistant to EN 60721-3-7, Class 7 M3	500 m/s ²
---	----------------------

Vibration-resistant to EN 60721-3-7, Class 7 M3	200 m/s ²
---	----------------------

Torsion and bending load	Not permitted
--------------------------	---------------

Design, dimensions and weight

Dimensions (L x W x H)	50 × 50 × 30 mm
------------------------	-----------------

Weight	60 g
--------	------

Type of mounting	2 x M5 screw 1.5 Nm
------------------	------------------------

Cable length, maximum	• RS-422: max. 1000 m • RS-232: max. 30 m
-----------------------	--

LED display design	3-color LED (operating voltage, presence, error)
--------------------	---

5.4.7 Approvals

FCC information

Siemens SIMATIC RF240R (MLFB 6GT2821-4AC10) FCC ID NXW-RF240R

Siemens SIMATIC RF240R (MLFB 6GT2821-4AC11) FCC ID NXW-RF240R

Siemens SIMATIC RF240R (MLFB 6GT2821-4AC40) FCC ID NXW-RF240R

This device complies with part 15 of the FCC rules. Operation is subject to the following two conditions:

- (1) This device may not cause harmful interference, and
- (2) this device must accept any interference received, including interference that may cause undesired operation.

Caution

Any changes or modifications not expressly approved by the party responsible for compliance could void the user's authority to operate the equipment.

Note

This equipment has been tested and found to comply with the limits for a Class A digital device, pursuant to part 15 of the FCC Rules.

These limits are designed to provide reasonable protection against harmful interference when the equipment is operated in a commercial environment. This equipment generates, uses, and can radiate radio frequency energy and, if not installed and used in accordance with the instruction manual, may cause harmful interference to radio communications. Operation of this equipment in a residential area is likely to cause harmful interference in which case the user will be required to correct the interference at his own expense.

IC information

This device complies with Industry Canada licence-exempt RSS standard(s). Operation is subject to the following two conditions:

- (1) This device may not cause interference, and
- (2) this device must accept any interference, including interference that may cause undesired operation of the device.

Le présent appareil est conforme aux CNR d'Industrie Canada applicables aux appareils radio exempts de licence. L'exploitation est autorisée aux deux conditions suivantes :

- (1) L'appareil ne doit pas produire de brouillage, et
- (2) l'utilisateur de l'appareil doit accepter tout brouillage radioélectrique subi, même si le brouillage est susceptible d'en compromettre le fonctionnement.

5.4.8 Dimension drawing

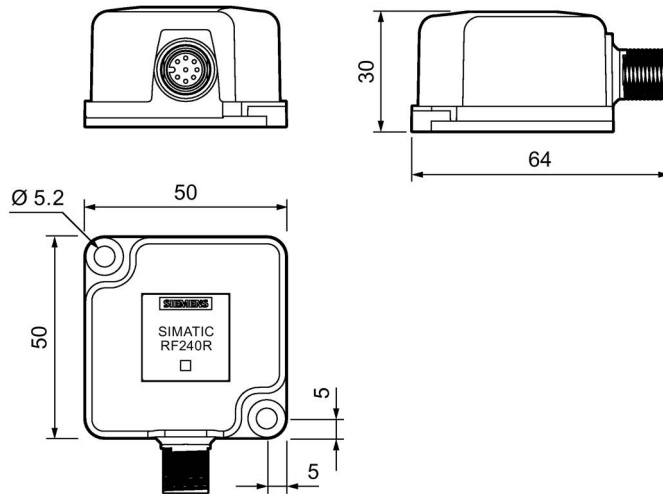

Figure 5-11 Dimension drawing RF240R

Dimensions in mm

5.5 SIMATIC RF250R

5.5.1 Features

SIMATIC RF250R	Characteristics	
	Structure	<ul style="list-style-type: none"> ① RS-422 or RS-232 interface ② Operating indicator ③ Antenna connector, M8
	Area of application	Identification tasks on assembly lines in harsh industrial environments

Note

Reader requires external antennas

Note that the RF250R reader is designed only for operation with external antennas and can only be operated in conjunction with the antennas ANT 3, ANT 8, ANT 12, ANT 18 or ANT 30.

5.5.2 Ordering data RF250R

	Article number
RF250R with RS-422 interface (3964R)	6GT2821-5AC10
RF250R with RS-232 interface (ASCII)	6GT2821-5AC40

5.5.3 Pin assignment RF250R

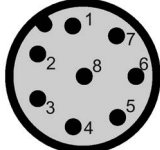

Pin	Pin Device end 8- pin M12	Interface assignment	
		RS-422	RS-232
	1	+24 V	+24 V
	2	- Transmit	RXD
	3	0 V	0 V
	4	+ Transmit	TXD
	5	+ Receive	Unassigned
	6	- Receive	Unassigned
	7	Unassigned	Unassigned
	8	Ground (shield)	Ground (shield)

5.5.4 LED operating display

The operational statuses of the reader are displayed by the LEDs. The LED can adopt the colors green, red or yellow and the statuses off □, on ■, flashing ■:

Table 5- 9 LED operating display on the reader

LED	Meaning
□	The reader is turned off.
■	Operating voltage present, reader not initialized or antenna switched off
■	Operating voltage present, reader initialized and antenna switched on

LED	Meaning
	<ul style="list-style-type: none"> Operating mode "with presence": Transponder present Operating mode "without presence": Transponder present and command currently being executed
	<p>There is an error. The number of flashes provides information about the current error. You can find more information on error messages in the section "Error codes of the RF200 readers (Page 329)". The optical error display is only reset if the corresponding reset parameter ("option_1 = 2") is set (see product information "SIMATIC RF200 Command Set (https://support.industry.siemens.com/cs/ww/en/view/44864850)").</p>

5.5.5 Technical specifications of the RF250R reader

Table 5- 10 Technical specifications of the RF250R reader

	6GT2821-5AC10
	6GT2821-5AC40
Product type designation	SIMATIC RF250R
Radio frequencies	
Operating frequency, rated value	13.56 MHz
Electrical data	
Maximum range	35 mm
Maximum data transmission speed reader ↔ transponder	ISO tags
• Read	• approx. 1500 bytes/s
• Write	• approx. 1500 bytes/s
Typical transmission time for user data per byte	
• for write access	• 0.6 or 1.2 ms
• for read access	• 0.6 or 1.2 ms
Transmission speed	19.2, 57.6, 115.2 kBd
Read/write distances of the reader	see section "Field data (Page 39)"
MTBF (Mean Time Between Failures)	430 years
Interfaces	
Electrical connector design	M8, 4-pin
Standard for interfaces for communication	
• RS-422	• 3964R protocol
• RS-232	• ASCII protocol

6GT2821-5AC10	
6GT2821-5AC40	
Antenna	external, ANT 8, ANT 12, ANT 18, ANT 30 can be connected
Mechanical specifications	
Housing	
• Material	• Plastic PA 6.6
• Color	• Anthracite
Recommended distance to metal	0 mm
Supply voltage, current consumption, power loss	
Supply voltage	24 VDC
Typical current consumption	50 mA
Permitted ambient conditions	
Ambient temperature	
• During operation	• -20 ... +70 °C
• During transportation and storage	• -25 ... +85 °C
Degree of protection to EN 60529	IP65
Shock-resistant to EN 60721-3-7, Class 7 M3	500 m/s ²
Vibration-resistant to EN 60721-3-7, Class 7 M3	200 m/s ²
Torsion and bending load	Not permitted
Design, dimensions and weight	
Dimensions (L x W x H)	50 × 50 × 30 mm
Weight	60 g
Type of mounting	2 x M5 screw 1.5 Nm
Cable length, maximum	• RS-422: max. 1000 m • RS-232: max. 30 m
LED display design	3-color LED

5.5.6 Approvals

FCC information

Siemens SIMATIC RF250R (MLFB 6GT2821-5AC10) FCC ID NXW-RF250R

Siemens SIMATIC RF250R (MLFB 6GT2821-5AC40) FCC ID NXW-RF250R

This device complies with part 15 of the FCC rules. Operation is subject to the following two conditions:

- (1) This device may not cause harmful interference, and
- (2) this device must accept any interference received, including interference that may cause undesired operation.

Caution

Any changes or modifications not expressly approved by the party responsible for compliance could void the user's authority to operate the equipment.

Note

This equipment has been tested and found to comply with the limits for a Class A digital device, pursuant to part 15 of the FCC Rules.

These limits are designed to provide reasonable protection against harmful interference when the equipment is operated in a commercial environment. This equipment generates, uses, and can radiate radio frequency energy and, if not installed and used in accordance with the instruction manual, may cause harmful interference to radio communications. Operation of this equipment in a residential area is likely to cause harmful interference in which case the user will be required to correct the interference at his own expense.

IC information

This device complies with Industry Canada licence-exempt RSS standard(s). Operation is subject to the following two conditions:

- (1) This device may not cause interference, and
- (2) this device must accept any interference, including interference that may cause undesired operation of the device.

Le présent appareil est conforme aux CNR d'Industrie Canada applicables aux appareils radio exempts de licence. L'exploitation est autorisée aux deux conditions suivantes :

- (1) L'appareil ne doit pas produire de brouillage, et
- (2) l'utilisateur de l'appareil doit accepter tout brouillage radioélectrique subi, même si le brouillage est susceptible d'en compromettre le fonctionnement.

If the antenna is detachable, require the following two conditions:

- (1) To reduce potential radio interference to other users, the antenna type should be chosen that the radiated power is not more than that permitted for successful communication.
- (2) This device has been designed to operate with the antennas listed below. Antennas not included in this list are strictly prohibited for use with this device. The required antenna impedance is 50 Ω .

Si l'antenne est amovible, demandez les deux conditions suivantes :

- (1) Afin de réduire le risque d'interférence aux autres utilisateurs, il faut choisir le type d'antenne et son gain de façon à ce que la puissance rayonnée ne soit pas supérieure au niveau requis pour l'obtention d'une communication satisfaisante.

(2) Ce dispositif a été conçu pour fonctionner avec les antennes énumérées ci-dessous. Les antennes non incluses dans cette liste sont strictement interdites pour l'exploitation de ce dispositif. L'impédance d'antenne requise est 50Ω .

5.5.7 Dimension drawing

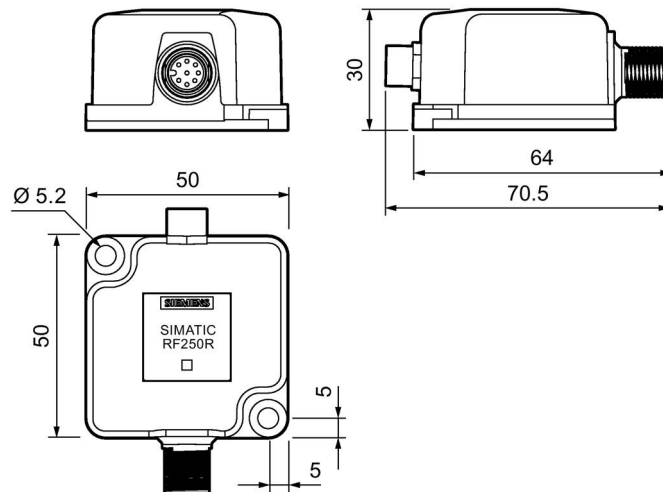



Figure 5-12 Dimension drawing RF250R

Dimensions in mm

5.6 SIMATIC RF260R

5.6.1 Features

SIMATIC RF260R	Characteristics	
	Structure	① RS-422 or RS-232 interface ② Operating indicator
	Field of application	Identification tasks on assembly lines in harsh industrial environments

5.6.2 Ordering data for RF260R

	Article number
RF260R with RS-422 interface (3964R)	6GT2821-6AC10
RF260R with RS-232 interface (3964R)	6GT2821-6AC11
RF260R with RS-232 interface (ASCII)	6GT2821-6AC40



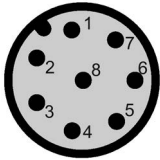

5.6.3 Pin assignment RF260R

Pin	Pin Device end 8- pin M12	Interface assignment	
		RS-422	RS-232
	1	+24 V	+24 V
	2	- Transmit	RXD
	3	0 V	0 V
	4	+ Transmit	TXD
	5	+ Receive	Unassigned
	6	- Receive	Unassigned
	7	Unassigned	Unassigned
	8	Ground (shield)	Ground (shield)

5.6.4 LED operating display

The operational statuses of the reader are displayed by the LEDs. The LED can adopt the colors green, red or yellow and the statuses off , on , flashing :

Table 5- 11 LED operating display on the reader

LED	Meaning
	The reader is turned off.
	Operating voltage present, reader not initialized or antenna switched off
	Operating voltage present, reader initialized and antenna switched on
	<ul style="list-style-type: none"> Operating mode "with presence": Transponder present Operating mode "without presence": Transponder present and command currently being executed
	There is an error. The number of flashes provides information about the current error. You can find more information on error messages in the section "Error codes of the RF200 readers (Page 329)". The optical error display is only reset if the corresponding reset parameter ("option_1 = 2") is set (see product information "SIMATIC RF200 Command Set (https://support.industry.siemens.com/cs/ww/en/view/44864850)").

5.6.5 Minimum distance between several RF260R

RF260R side by side

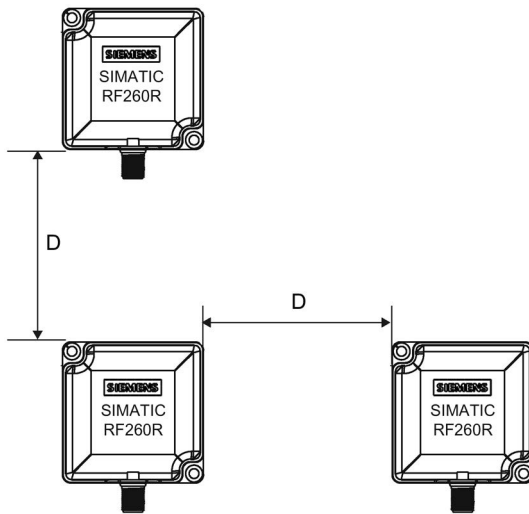

- D ≥ 150 mm (with 2 readers)
- D ≥ 250 mm (with more than 2 readers)

Figure 5-13 Minimum distance between several RF260R

RF260R face to face

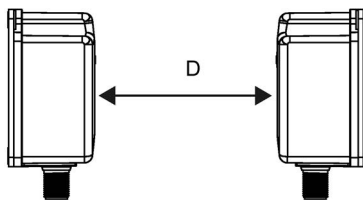

- D ≥ 500 mm

Figure 5-14 Face-to-face distance between two RF260R

5.6.6 Technical data of the RF260R reader

Table 5- 12 Technical specifications of the RF260R reader

	6GT2821-6AC10 6GT2821-6AC11 6GT2821-6AC40
Product type designation	SIMATIC RF260R
Radio frequencies	
Operating frequency, rated value	13.56 MHz
Electrical data	
Maximum range	135 mm
Maximum data transmission speed reader ↔ transponder	ISO tags
• Read	• approx. 1500 bytes/s
• Write	• approx. 1500 bytes/s
Typical transmission time for user data per byte	
• for write access	• 0.6 ms
• for read access	• 0.6 ms
Transmission speed	19.2, 57.6, 115.2 kBd
Read/write distances of the reader	see section "Field data (Page 39)"
MTBF (Mean Time Between Failures)	480 years
Interfaces	
Electrical connector design	M12, 8-pin
Standard for interfaces for communication	
• 6GT2821-6AC10	• RS-422 (3964R protocol)
• 6GT2821-6AC11	• RS-232 (3964R protocol)
• 6GT2821-6AC40	• RS-232 (ASCII protocol)
Antenna	integrated
Mechanical specifications	
Housing	
• Material	• Plastic PA 6.6
• Color	• Anthracite
Recommended distance to metal	0 mm
Supply voltage, current consumption, power loss	

	6GT2821-6AC10
	6GT2821-6AC11
	6GT2821-6AC40
Supply voltage	24 VDC
Typical current consumption	50 mA
Permitted ambient conditions	
Ambient temperature	
• During operation	• -20 ... +70 °C
• During transportation and storage	• -25 ... +80 °C
Degree of protection to EN 60529	IP67
Shock-resistant to EN 60721-3-7, Class 7 M3	500 m/s ²
Vibration-resistant to EN 60721-3-7, Class 7 M3	200 m/s ²
Torsion and bending load	Not permitted
Design, dimensions and weight	
Dimensions (L x W x H)	75 × 75 × 41 mm
Weight	200 g
Type of mounting	2 x M5 screw 1.5 Nm
Cable length, maximum	• RS-422: max. 1000 m • RS-232: max. 30 m
LED display design	3-color LED (operating voltage, presence, error)

5.6.7 Approvals

FCC information

Siemens SIMATIC RF260R (MLFB 6GT2821-6AC10) FCC ID NXW-RF260R

Siemens SIMATIC RF260R (MLFB 6GT2821-6AC11) FCC ID NXW-RF260R

Siemens SIMATIC RF260R (MLFB 6GT2821-6AC40) FCC ID NXW-RF260R

This device complies with part 15 of the FCC rules. Operation is subject to the following two conditions:

- (1) This device may not cause harmful interference, and
- (2) this device must accept any interference received, including interference that may cause undesired operation.

Caution

Any changes or modifications not expressly approved by the party responsible for compliance could void the user's authority to operate the equipment.

Note

This equipment has been tested and found to comply with the limits for a Class A digital device, pursuant to part 15 of the FCC Rules.

These limits are designed to provide reasonable protection against harmful interference when the equipment is operated in a commercial environment. This equipment generates, uses, and can radiate radio frequency energy and, if not installed and used in accordance with the instruction manual, may cause harmful interference to radio communications. Operation of this equipment in a residential area is likely to cause harmful interference in which case the user will be required to correct the interference at his own expense.

IC information

This device complies with Industry Canada licence-exempt RSS standard(s). Operation is subject to the following two conditions:

- (1) This device may not cause interference, and
- (2) this device must accept any interference, including interference that may cause undesired operation of the device.

Le présent appareil est conforme aux CNR d'Industrie Canada applicables aux appareils radio exempts de licence. L'exploitation est autorisée aux deux conditions suivantes :

- (1) L'appareil ne doit pas produire de brouillage, et
- (2) l'utilisateur de l'appareil doit accepter tout brouillage radioélectrique subi, même si le brouillage est susceptible d'en compromettre le fonctionnement.



5.6.8 Dimension drawing

Figure 5-15 Dimension drawing RF260R

Dimensions in mm

5.7 SIMATIC RF280R

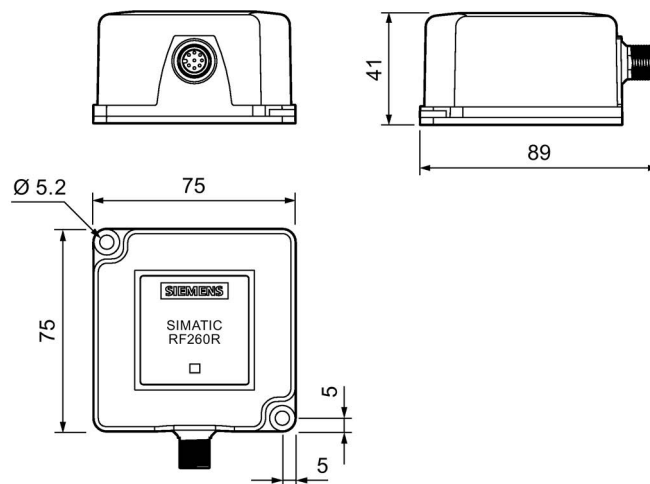
5.7.1 Features

SIMATIC RF280R	Characteristics	
	Structure	① RS-422 or RS-232 interface ② Operating indicator
	Field of application	Identification tasks on assembly lines in harsh industrial environments

5.7.2 Ordering data RF280R

	Article number
RF280R with RS422 interface (3964R)	6GT2821-8AC10
RF280R with RS232 interface (ASCII)	6GT2821-8AC40



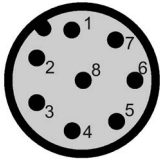

5.7.3 Pin assignment RF280R

Pin	Pin Device end 8- pin M12	Interface assignment	
		RS-422	RS-232
	1	+24 V	+24 V
	2	- Transmit	RXD
	3	0 V	0 V
	4	+ Transmit	TXD
	5	+ Receive	Unassigned
	6	- Receive	Unassigned
	7	Unassigned	Unassigned
	8	Ground (shield)	Ground (shield)

5.7.4 LED operating display

The operational statuses of the reader are displayed by the LEDs. The LED can adopt the colors green, red or yellow and the statuses off , on , flashing :

Table 5- 13 LED operating display on the reader

LED	Meaning
	The reader is turned off.
	Operating voltage present, reader not initialized or antenna switched off
	Operating voltage present, reader initialized and antenna switched on
	<ul style="list-style-type: none"> Operating mode "with presence": Transponder present Operating mode "without presence": Transponder present and command currently being executed
	There is an error. The number of flashes provides information about the current error. You can find more information on error messages in the section "Error codes of the RF200 readers (Page 329)". The optical error display is only reset if the corresponding reset parameter ("option_1 = 2") is set (see product information "SIMATIC RF200 Command Set (https://support.industry.siemens.com/cs/ww/en/view/44864850)").

5.7.5 Minimum distance between RF280R readers

RF280R side-by-side

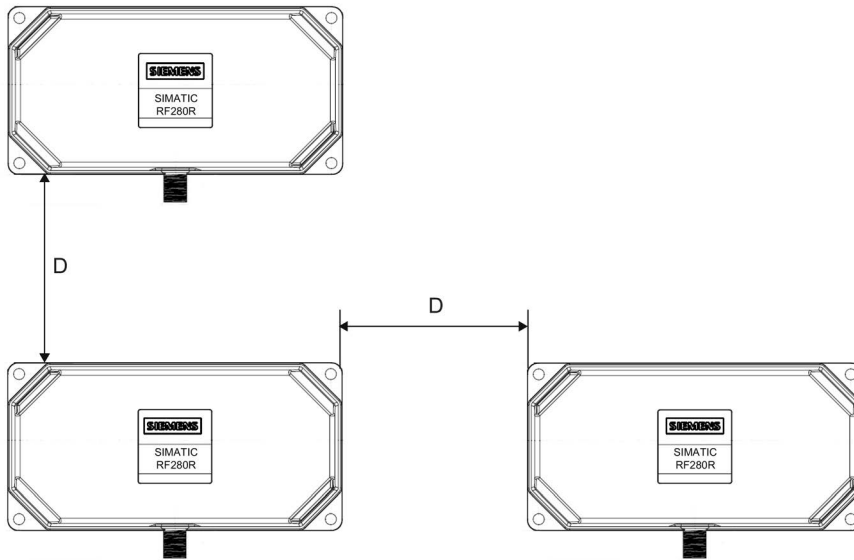

- D ≥ 150 mm (with 2 readers)
- D ≥ 250 mm (with more than 2 readers)

Figure 5-16 Minimum distance between RF280R readers

RF280R Face-to-Face

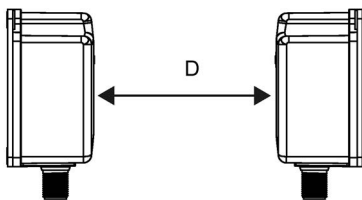

- D ≥ 800 mm

Figure 5-17 Face-to-face distance between two RF280R

5.7.6 Technical specifications of the RF280R reader

Table 5- 14 Technical specifications of the RF280R reader

	6GT2821-8AC10 6GT2821-8AC40
Product type designation	SIMATIC RF280R
Radio frequencies	
Operating frequency, rated value	13.56 MHz
Electrical data	
Maximum range	200 mm
Maximum data transmission speed reader ↔ transponder	ISO transponder
• Read	• approx. 1500 bytes/s
• Write	• approx. 1500 bytes/s
Typical transmission time for user data per byte	
• for write access	• 0.6 ms
• for read access	• 0.6 ms
Transmission speed	19.2, 57.6, 115.2 kBd
Read/write distances of the reader	see section "Field data (Page 39)"
MTBF (Mean Time Between Failures)	172.6 years
Interfaces	
Electrical connector design	M12, 8-pin
Standard for interfaces for communication	
• 6GT2821-6AC10	• RS-422 (3964R protocol)
• 6GT2821-6AC40	• RS-232 (ASCII protocol)
Antenna	integrated
Mechanical specifications	
Housing	
• Material	• Plastic PA 12
• Color	• TI grey
Recommended distance to metal	0 mm
Supply voltage, current consumption, power loss	
Supply voltage	24 VDC
Typical current consumption	130 mA

	6GT2821-8AC10
	6GT2821-8AC40
Permitted ambient conditions	
Ambient temperature	
• During operation	• -25 ... +70 °C
• During transportation and storage	• -40 ... +85 °C
Degree of protection to EN 60529	IP67
Shock-resistant to EN 60721-3-7, Class 7 M3	500 m/s ²
Vibration-resistant to EN 60721-3-7, Class 7 M3	200 m/s ²
Torsion and bending load	Not permitted
Design, dimensions and weight	
Dimensions (L x W x H)	160 x 80 x 41 mm
Weight	470 g
Type of mounting	4x screws M5 ≤ 1.5 Nm
Cable length, maximum	• RS-422: max. 1000 m • RS-232: max. 30 m
LED display design	3-color LED (operating voltage, presence, error)
Standards, specifications, approvals	
Proof of suitability	Radio according to R&TTE directives EN 300330, EN 301489, CE, FCC, UL/CSA

5.7.7 Approvals

FCC information

Siemens SIMATIC RF280R (MLFB 6GT2821-8AC10) FCC ID NXW-RF280R

Siemens SIMATIC RF280R (MLFB 6GT2821-8AC40) FCC ID NXW-RF280R

This device complies with part 15 of the FCC rules. Operation is subject to the following two conditions:

- (1) This device may not cause harmful interference, and
- (2) this device must accept any interference received, including interference that may cause undesired operation.

Caution

Any changes or modifications not expressly approved by the party responsible for compliance could void the user's authority to operate the equipment.

Note

This equipment has been tested and found to comply with the limits for a Class A digital device, pursuant to part 15 of the FCC Rules.

These limits are designed to provide reasonable protection against harmful interference when the equipment is operated in a commercial environment. This equipment generates, uses, and can radiate radio frequency energy and, if not installed and used in accordance with the instruction manual, may cause harmful interference to radio communications. Operation of this equipment in a residential area is likely to cause harmful interference in which case the user will be required to correct the interference at his own expense.

IC information

This device complies with Industry Canada licence-exempt RSS standard(s). Operation is subject to the following two conditions:

- (1) This device may not cause interference, and
- (2) this device must accept any interference, including interference that may cause undesired operation of the device.

Le présent appareil est conforme aux CNR d'Industrie Canada applicables aux appareils radio exempts de licence. L'exploitation est autorisée aux deux conditions suivantes :

- (1) L'appareil ne doit pas produire de brouillage, et
- (2) l'utilisateur de l'appareil doit accepter tout brouillage radioélectrique subi, même si le brouillage est susceptible d'en compromettre le fonctionnement.

5.7.8 Dimension drawing

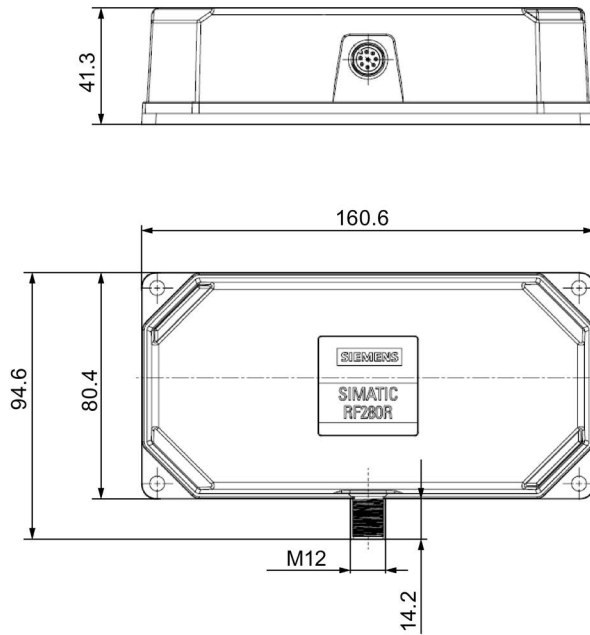



Figure 5-18 Dimensional drawing of RF280R

Dimensions in mm

5.8 SIMATIC RF290R

5.8.1 Features

SIMATIC RF290R	Characteristics	
	Design	<ul style="list-style-type: none"> ① RS-422/RS-232 interface, 24 V power supply ② Digital I/O ③ External antenna ④ Operating display, 4 LEDs: <ul style="list-style-type: none"> • Power (PWR) • Active (ACT) • Present (PRE) • Error (ERR)
	Application	Identification tasks in production control and in intra-logistics, e.g. skid identification, container management, HF gates (F&B) When connected via a PC multitag operation is possible.

Note

Reader requires external antennas

Note that the RF290R reader is designed only for operation with external antennas and can only be operated in conjunction with the antennas ANT D5, D6 or D10.

Note

Note on operating the reader with ANT D6 / D10

When operating with a power ≥ 3 W, the limits are adhered to according to 2004/40/EC (minimum requirements concerning the protection of workers). Note that the antennas may only be used in an "industrial environment" and not in buildings used by the public.

5.8.2 Ordering data RF290R

Table 5- 15 Ordering data RF290R

	Article number
RF290R with RS-232 interface for PC mode and RS-422 interface for CM mode	6GT2821-0AC12

Table 5- 16 Ordering data - accessories - RF290R

		Article number
24 V connecting cable	5 m	6GT2491-1HH50
RS-232 connecting cable, with 4-pin M12 connector for 24 V for connection to the wide-range power supply unit	5 m	6GT2891-4KH50
RS-232 connecting cable with open cable ends for 24 V	5 m	6GT2891-4KH50-0AX0
Adapter for mounting on a DIN rail (pack of 3)		6GK5798-8ML00-0AB3
Wide-range power supply unit for SIMATIC RF-systems (100 - 240 VAC / 24 VDC / 3 A) with 2 m connecting cable with country-specific plug		EU: 6GT2898-0AA00 UK: 6GT2898-0AA10 US: 6GT2898-0AA20
Connecting cables		
Reader ↔ ASM 475	2 m	6GT2891-4EH20
	5 m	6GT2891-4EH50
Connecting / extension cable		
Reader ↔ CM/ASM for RF200 / RF300 / RF600 / MV400 or extension cable MOBY U/D	2 m	6GT2891-4FH20
	5 m	6GT2891-4FH50
	10 m	6GT2891-4FN10
	20 m	6GT2891-4FN20
	50 m	6GT2891-4FN50
Antennas		
Antenna ANT D5		6GT2698-5AA10
Antenna ANT D6		6GT2698-5AB00
Covering hood for ANT D6		6GT2690-0AD00
Antenna ANT D10		6GT2698-5AF00
Accessories for connecting multiple antennas to SIMATIC RF290R		
Antenna multiplexer incl. one antenna connecting cable 0.4 m		6GT2894-0EA00
Antenna splitter incl. one antenna connecting cable 3.3 m		6GT2690-0AC00
Antenna cables		
Antenna cable	3.3 m	6GT2691-0CH33
	10.5 m	6GT2691-0CN10
Antenna cable extension	7.2 m	6GT2691-0DH72

5.8.3 Pin assignment RF290R

RS422/RS232

Table 5- 17 Pin assignment of the RS-422/RS 232 interface

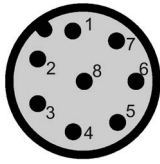
Pin	Pin Device end 8- pin M12	Interface assignment	
		RS-422	RS-232
	1	+24 V	+24 V
	2	- Transmit	RXD
	3	0 V	0 V
	4	+ Transmit	TXD
	5	+ Receive	not used
	6	- Receive	not used
	7	not used	not used
	8	Ground (shield)	Ground (shield)

Digital I/O

only possible in PC mode (RS-232)

Table 5- 18 Pin assignment of the digital I/O interface

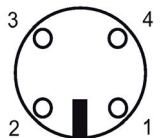
Pin	Pin Device end 4- pin M12	Socket assignment
	1	DO - relay contact COM (Common)
	2	DO - relay contact NO (Normaly Open, NO contact)
	3	DI - switched input, +24 V
	4	DI - ground, 0 V

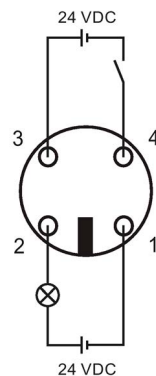

Figure 5-19 Pin assignment of the power supply connector

Digital input (DI):

The opto-coupler input is electrically isolated from the reader electronics. The external 24 V must be connected to the DI according to the circuit diagram. Make sure that the polarity of the 24 V is correct. The current is limited to < 10 mA by the integrated resistor.

NOTICE
Reader may be damaged If you exceed the maximum permitted supply voltage, the reader may be damaged. Make sure that the input voltage does not exceed the maximum permitted supply voltage of the reader.

Digital output (DO):







At the relay output, a NO contact is available. The output is electrically isolated from the reader electronics and therefore needs to be supplied externally.

NOTICE
Reader may be damaged If you exceed the maximum permitted voltage of 24 V / 1 A at the relay output, the reader may be damaged. Make sure that the voltage does not exceed 24 V. The output is intended only for switching resistive loads. If it is used to switch inductive loads, the reader may be damaged. Make sure that if inductive loads occur, the relay contacts are protected by an external suppressor circuit.

5.8.4 LED operating display

The operational statuses of the reader are displayed by the LEDs. The LED can adopt the colors green, red or yellow and the statuses off , on , flashing :

Table 5- 19 LED operating display on the reader

Labeling	LED	Meaning
-		The reader is turned off.
PWR		CM mode: Operating voltage present, reader not initialized or antenna switched off
		CM mode: Operating voltage present, reader initialized and antenna switched on PC mode: Supply voltage is on
ACT		Communication on the data line
PRE		<ul style="list-style-type: none"> Operating mode "with presence": Transponder present Operating mode "without presence": Transponder present and command currently being executed
ERR		CM mode: There is an error. The number of flashes provides information about the current error. You can find more information on error messages in the section "Error codes of the RF200 readers (Page 329)". The optical error display is only reset if the corresponding reset parameter ("option_1 = 2") is set (see Product Information " Product information "SIMATIC RF200 command set" (https://support.industry.siemens.com/cs/ww/en/view/44864850)).
		PC mode: Error when connecting the antenna or the interference level in the antenna environment is too high

5.8.5 Installing the RF290R reader

5.8.5.1 Wall mounting

Use the holes in the housing to screw the device to the wall or onto a horizontal surface. The position of the drill holes is shown in the following figure:

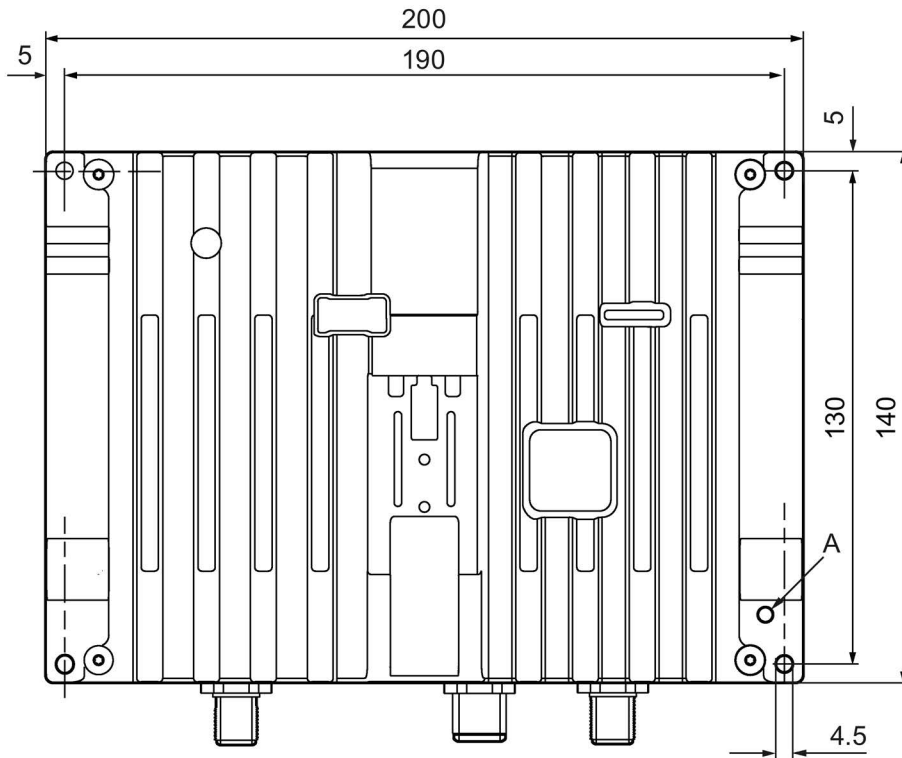

Figure 5-20 Drilling pattern for the RF290R (dimensions in mm)

A: M4 threaded socket for potential connection of the reader. You will find further information on the potential connection in the section "Further information (Page 101)".

5.8.5.2 Installing on the S7-300 standard rail

Follow the steps below to mount the RF290R reader on a vertical S7-300 standard rail:

1. Place the device on the upper edge of the S7-300 standard rail (position A).
2. Screw the device to the mounting rail (position B).

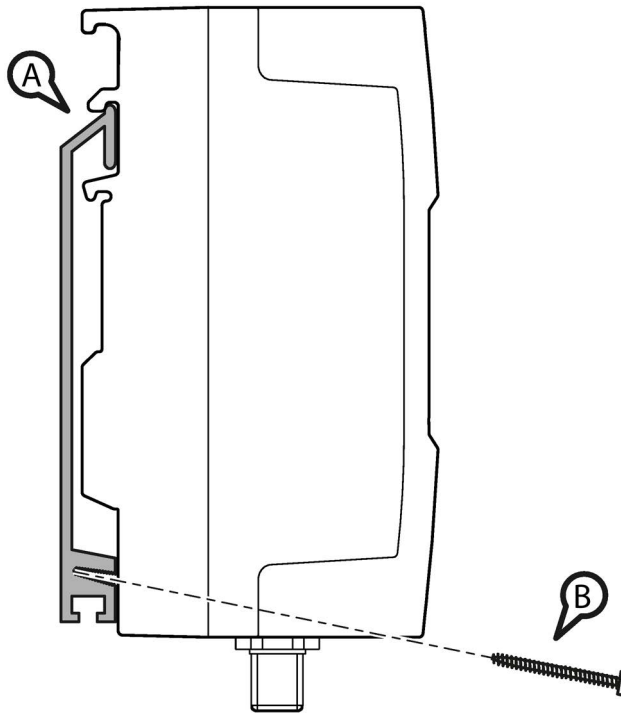

Figure 5-21 Installing the RF290R reader on the S7-300 standard rail

5.8.5.3 Installation on a DIN rail

The RF290R reader is suitable for installation on 35 mm rails that comply with DIN EN 50022.

Note

The adapter for mounting on a DIN rail does not ship with the RF290R

The adapter for mounting on a DIN rail does not ship with the product. You can obtain a pack of three with the following article number: 6GK5798-8ML00-0AB3.

The mounting fittings consist of the following parts:

- 1 DIN rail slider
 - 1 spring
 - 2 screws
-

Fit the adapter to the rear of the device as shown in the following figure:

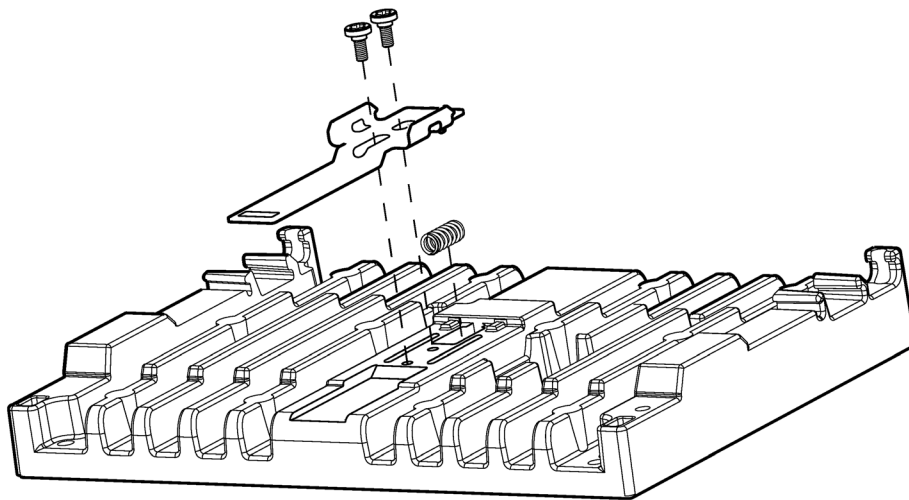

Figure 5-22 Mounting the DIN rail adapter

Follow the steps below to mount the RF290R reader on a DIN rail:

1. Place the device on the upper edge of the DIN rail (position A).
2. Pull the spring-mounted DIN rail slider (position B) down and press the device against the DIN rail until it locks in place.

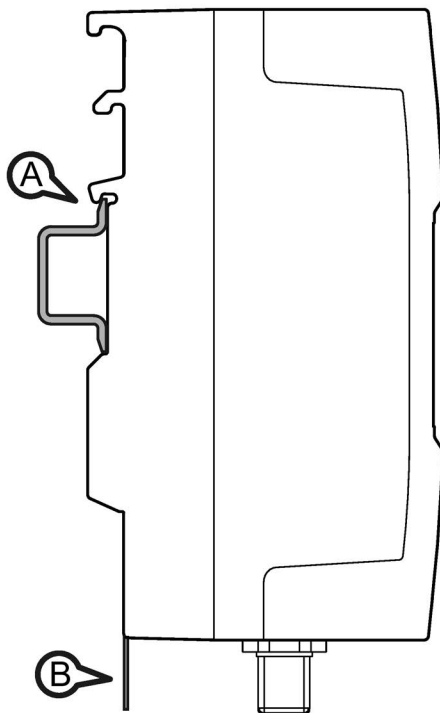

Figure 5-23 Mounting the RF290R reader on a DIN rail

5.8.6 Technical specifications of the RF290R reader

Table 5- 20 Technical specifications of the RF290R reader

6GT2821-0AC12	
Product type designation	SIMATIC RF290R
Radio frequencies	
Operating frequency, rated value	13.56 MHz
Electrical data	
Maximum range	65 mm
Maximum data transmission speed reader ↔ transponder	ISO tags
• Read	• approx. 1500 bytes/s
• Write	• approx. 1500 bytes/s
Typical transmission time for user data per byte	
• for write access	• 0.6 ms
• for read access	• 0.6 ms
Multitag capability	When connected via a PC
Transmission speed	19.2, 57.6, 115.2 kBd
Read/write distances of the reader	see section "Field data (Page 39)"
MTBF (Mean Time Between Failures)	18 years
Interfaces	
Electrical connector design	TNC
Standard for interfaces for communication	<ul style="list-style-type: none"> • RS-422 • RS-232
Antenna	external, ANT D5, D6 or D10 can be connected
Mechanical specifications	
Housing	
• Material	• Aluminum die-casting
• Color	• Silver/anthracite
Recommended distance to metal	0 mm
Supply voltage, current consumption, power loss	
Supply voltage	24 VDC (± 10%)
Typical current consumption	400 mA (at 24 V and 5 W)

6GT2821-0AC12

Permitted ambient conditions

Ambient temperature

- | | |
|-------------------------------------|------------------|
| • During operation | • -20 ... +55 °C |
| • During transportation and storage | • -25 ... +85 °C |

Degree of protection to EN 60529 IP65

Shock-resistant to EN 60721-3-7, Class 7 M3 300 m/s²Vibration-resistant to EN 60721-3-7, Class 7 M3 20 m/s²

Torsion and bending load Not permitted

Design, dimensions and weight

Dimensions (W x H x D) 200 × 80 × 140 mm

Weight 1.8 kg

Type of mounting 2 x M5 screw
1.5 NmCable length, maximum

- RS-422: max. 1000 m
- RS-232: max. 30 m

LED display design 4 LEDs

5.8.7 Approvals**FCC information****Siemens SIMATIC RF290R (MLFB 6GT2821-0AC12) FCC ID NXW-RF290R**

This device complies with part 15 of the FCC rules. Operation is subject to the following two conditions:

- (1) This device may not cause harmful interference, and
- (2) this device must accept any interference received, including interference that may cause undesired operation.

Caution

Any changes or modifications not expressly approved by the party responsible for compliance could void the user's authority to operate the equipment.

Note

This equipment has been tested and found to comply with the limits for a Class A digital device, pursuant to part 15 of the FCC Rules.

These limits are designed to provide reasonable protection against harmful interference when the equipment is operated in a commercial environment. This equipment generates, uses, and can radiate radio frequency energy and, if not installed and used in accordance with the instruction manual, may cause harmful interference to radio communications. Operation of this equipment in a residential area is likely to cause harmful interference in which case the user will be required to correct the interference at his own expense.

IC information

This device complies with Industry Canada licence-exempt RSS standard(s). Operation is subject to the following two conditions:

- (1) This device may not cause interference, and
- (2) this device must accept any interference, including interference that may cause undesired operation of the device.

Le présent appareil est conforme aux CNR d'Industrie Canada applicables aux appareils radio exempts de licence. L'exploitation est autorisée aux deux conditions suivantes :

- (1) L'appareil ne doit pas produire de brouillage, et
- (2) l'utilisateur de l'appareil doit accepter tout brouillage radioélectrique subi, même si le brouillage est susceptible d'en compromettre le fonctionnement.

If the antenna is detachable, require the following two conditions:

- (1) To reduce potential radio interference to other users, the antenna type should be chosen that the radiated power is not more than that permitted for successful communication.
- (2) This device has been designed to operate with the antennas listed below. Antennas not included in this list are strictly prohibited for use with this device. The required antenna impedance is 50 Ω .

Si l'antenne est amovible, demandez les deux conditions suivantes :

- (1) Afin de réduire le risque d'interférence aux autres utilisateurs, il faut choisir le type d'antenne et son gain de façon à ce que la puissance rayonnée ne soit pas supérieure au niveau requis pour l'obtention d'une communication satisfaisante.
- (2) Ce dispositif a été conçu pour fonctionner avec les antennes énumérées ci-dessous. Les antennes non incluses dans cette liste sont strictement interdites pour l'exploitation de ce dispositif. L'impédance d'antenne requise est 50 Ω .

5.8.8 Note on the use of the RF290R as a replacement for SLG D10 / SLG D10S

The RF290R reader is the successor to the MOBY D readers SLG D10 / SLG D10S rounding off the RF200 family; it is operated with external antennas. The following features distinguish the RF290R from the SLG models:

Table 5- 21 Differences between the RF290R readers and SLG D10 / SLG D10S

Properties SLG D10/SLG D10S	Properties RF290R
Two devices with different interfaces	RS-232/RS-422 interface and PC/CM functionality in one device
M 12, 4-pin male connector for the power supply 9-pin D-sub male connector for connection to the various communications modules	M12, 8-pin male connector for the power supply and for direct connection to the various communications modules ¹⁾
no digital I/O	M12, 4-pin female connector for digital I/O (can only be used in PC mode)
no operating display via LEDs	operating display by four LEDs
Maximum transmit power of 10 W	Maximum transmit power of 5 W
One securing option	Different securing options
Standard protocol in ISO host mode (in PC mode)	Advanced protocol in ISO host mode (in PC mode) ²⁾
Amplitude Shift Keying (ASK) and Frequency Shift Keying (FSK) modes possible	Amplitude Shift Keying (ASK) mode possible
Support of "ICode1" and "TagIt" and ISO 15693-compatible transponders	Support of ISO 15693-compatible transponders
The total memory for "repeat_command" is limited to 32 kB	The total memory for "repeat_command" is limited to 16 kB

¹⁾ The RF290R reader connectors are compatible with the SLG D10 if a Y connecting cable is used (6GT2891-4KH50, 6GT2891-4KH50-0AX0).

²⁾ In ISO host mode (in PC mode), a program adaptation is necessary

5.8.9 Dimension drawing

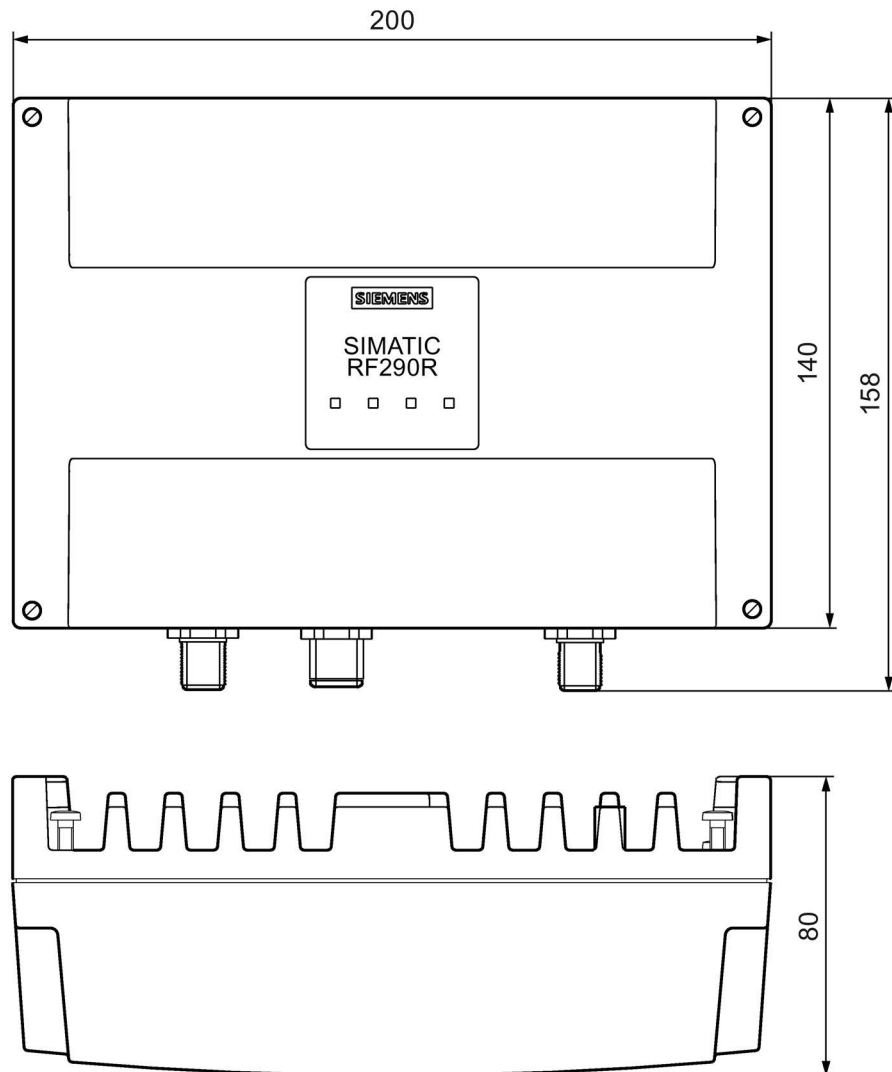

Figure 5-24 Dimensional drawing RF290R (dimensions in mm)

Antennas

Note

The RF250R and RF290R readers require external antennas

Note that the RF250R and RF290R readers are designed for operation with external antennas.

The RF250R reader can only be used in conjunction with the antennas ANT 3, 8, 12, 18 or 30. The RF290R reader can only be used in conjunction with the antennas ANT D5, D6 or D10.

6.1 ANT 1

6.1.1 Characteristics

ANT 1	Characteristics	
	Area of application	Small assembly lines
	Read/write distance	up to 140 mm (depending on the transponder)
	Connecting cable	3 m (plug-in antenna cable)
	Connectable readers	RF250R
	Degree of protection	IP67

6.1.2 Ordering data

Table 6- 1 Ordering data ANT 1

Antenna	Article number
ANT 1 (including one plug-in antenna cable 3 m)	6GT2398-1CB00

Table 6- 2 Ordering data ANT 1 accessories

Accessories	Article number
Antenna cable, 3 m	6GT2398-0AH30

6.1.3 Flush-mounted in metal

The tuning of the ANT 1 antenna is optimized for mounting in metal.

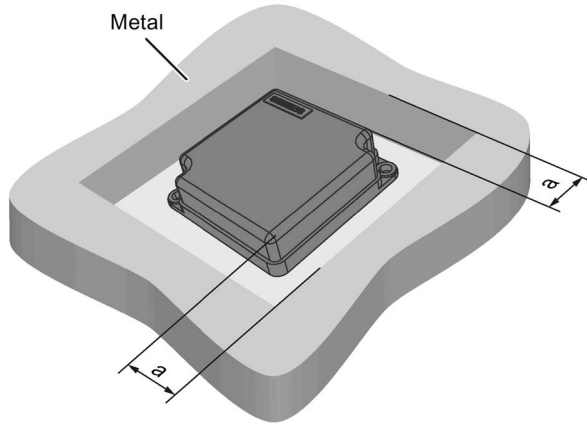

a = 40 mm

Figure 6-1 ANT 1 flush-mounted in metal

6.1.4 Operating / limit distances

The operating / limit distances listed in the following table relate to an ANT 1 mounted in metal.

Table 6-3 Operating / limit distances of the transponders

	RF250R with ANT 1 Operating distance (S _a)	RF250R with ANT 1 Limit distance (S _g)
MDS D100	5...110	140
MDS D124	2...65	85
MDS D126	2...90	120
MDS D139	5...85	115
MDS D160	2...35	60
MDS D165	5...100	120
MDS D200	5...95	115
MDS D261	5...80	95
MDS D324	2...66	78
MDS D339	5...90	105
MDS D400	2...110	135
MDS D423	10...40	50
MDS D424	2...75	88
MDS D425	2...25	35
MDS D426	2...85	95
MDS D428	2...40	50

	RF250R with ANT 1 Operating distance (S _a)	RF250R with ANT 1 Limit distance (S _g)
MDS D460	2...32	38
MDS D524	2...65	85
MDS D525	2...25	35
MDS D526	2...85	105
MDS D528	2...35	50

All values are in mm

6.1.5 Minimum clearances

Note

Extension of the data transmission time if distance values are undershot

If the distance values specified in the tables are undershot, it is possible that the inductive fields will be affected. In this case, the data transmission time can increase unpredictably or a command is aborted with an error.

For this reason, please observe the values in the tables.

Minimum distances from transponder to transponder (without multitag mode)

Table 6- 4 Minimum distances transponder edge to transponder edge

	MDS D423 / MDS D425	MDS D126 / MDS D160 / MDS D165 / MDS D200 / MDS D339 / MDS D426 / MDS D428 / MDS D460	MDS D100 / MDS D124 / MDS D139 / MDS D 261 / MDS D400 / MDS D424
RF250R with ANT 1	≥ 120 mm	≥ 150 mm	≥ 240 mm

Minimum distances from antenna to antenna

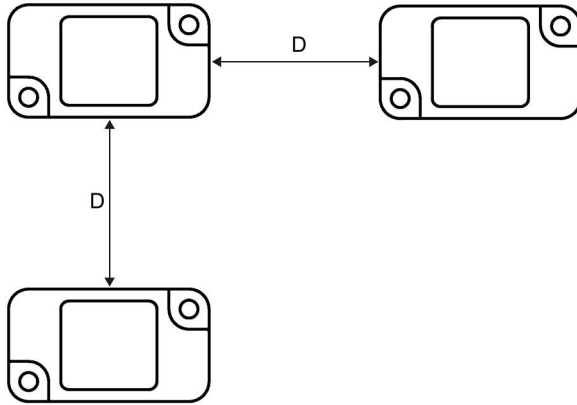

$D \geq 300 \text{ mm}$

Figure 6-2 Minimum distance ANT 1

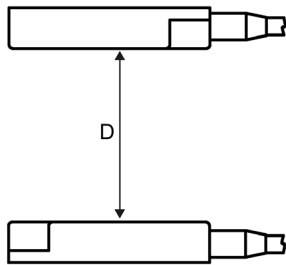

$D \geq 500 \text{ mm}$

Figure 6-3 Face-to-face minimum distance ANT 1

6.1.6 Technical specifications

6GT2398-1CB00	
Product type designation	ANT 1
Electrical data	
Maximum write/read distance ANT ↔ Transponder (S _g)	140 mm
Interfaces	
Plug connection	M8, 4-pin; pins on antenna side

6GT2398-1CB00

Mechanical specifications

Housing

• Material	• Plastic PA 12
• Color	• Anthracite
MTBF	13698 years

Permitted ambient conditions

Ambient temperature

• During operation	• -25 °C ... +70 °C
• During transportation and storage	• -40 °C ... +85 °C

Degree of protection to EN 60529	IP67
----------------------------------	------

Shock according to EN 60721-3-7 Class 7 M3 ¹⁾	500 m/s ²
--	----------------------

Vibration according to EN 60721-3-7 Class 7 M3 ¹⁾	200 m/s ²
--	----------------------

Design, dimensions and weight

Dimensions (L × W × H)	75 x 75 x 20 mm
------------------------	-----------------

Weight	225 g
--------	-------

Type of mounting	2 x M5 screws
------------------	---------------

Cable length	3 m (plug-in antenna cable)
--------------	-----------------------------

¹⁾ Warning: The values for shock and vibration are maximum values and must not be applied continuously.

6.1.7 Dimension drawing

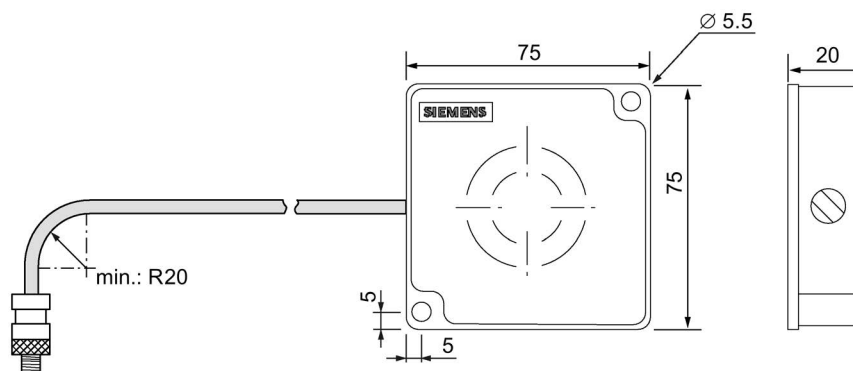



Figure 6-4 Dimensional drawing of ANT 1 (all values in mm)

6.2 ANT 3

6.2.1 Features

ANT 3	Characteristics	
	Area of application	Small assembly lines
	Writing/reading distance	up to 50 mm (depending on the transponder)
	Connecting cable	3 m (plug-in antenna cable)
	Connectable readers	RF250R
	Degree of protection	IP67

6.2.2 Ordering data

Table 6- 5 Ordering data ANT 3

Antenna	Article number
ANT 3 (without antenna cable)	6GT2398-1CD30-0AX0
ANT 3 (incl. one plug-in antenna cable 3 m)	6GT2398-1CD40-0AX0

Table 6- 6 Ordering data ANT 3 accessories

Accessories	Article number
Antenna cable, 3 m	6GT2398-0AH30

6.2.3 Mounting on/in metal

The tuning of the ANT 3 antenna is optimized for mounting on metal.

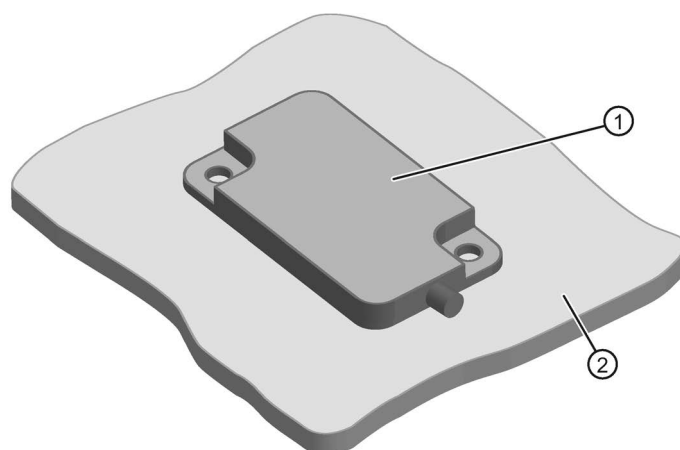

- ① ANT 3
- ② Metal

Figure 6-5 ANT 3 mounted on metal

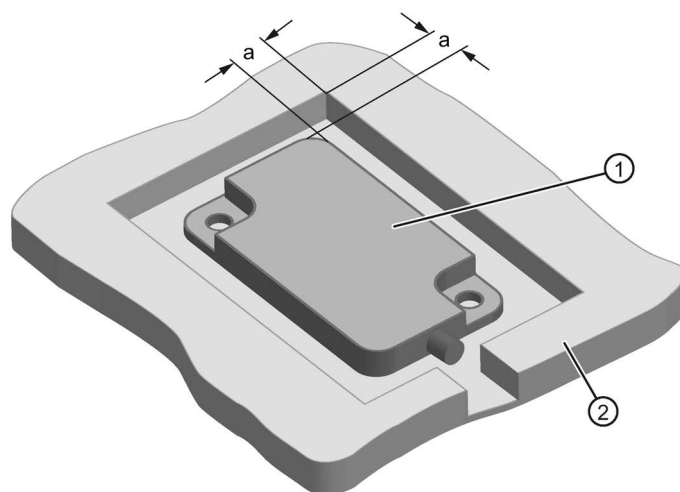

- ① ANT 3
- ② Metal
- a = 10 mm

Figure 6-6 ANT 3 flush-mounted in metal

6.2.4 Operating / limit distances

The operating / limit distances listed in the following table relate to an ANT 3 mounted on metal.

Table 6- 7 Operating / limit distances of the transponders

	RF250R with ANT 3 Operating distance (S _a)	RF250R with ANT 3 Limit distance (S _g)
MDS D124	2 ... 32	40
MDS D160	1 ... 16	20
MDS D324	2 ... 32	40
MDS D422	1 ... 12	15
MDS D423 (without metal)	0 ... 20	25
MDS D423 (on metal)	0 ... 24	30
MDS D423 (in metal - 10 mm clearance all round)	0 ... 24	30
MDS D423 (in metal - 0 mm clearance all round)	0 ... 16	20
MDS D424	0 ... 45	50
MDS D425	0 ... 16	20
MDS D428	0 ... 25	32
MDS D460	0 ... 18	25
MDS D522	1 ... 12	15
MDS D522 Special variant	1 ... 12	15
MDS D524	1 ... 30	40
MDS D528	1 ... 20	25

All values are in mm

6.2.5 Minimum spacing

Note

Extension of the data transmission time if distance values are undershot

If the distance values specified in the tables are undershot, it is possible that the inductive fields will be affected. In this case, the data transmission time can increase unpredictably or a command is aborted with an error.

For this reason, please observe the values in the tables.

Minimum distances from transponder to transponder (without multitag mode)

Table 6- 8 Minimum distances transponder edge to transponder edge

	MDS D124 / MDS D160 / MDS D324 / MDS D423 / MDS D424 / MDS D428 / MDS D460 / MDS D524 / MDS D528	MDS D422 / MDS D425 / MDS D522
RF250R with ANT 3	> 80 mm	> 60 mm

Minimum distances from antenna to antenna

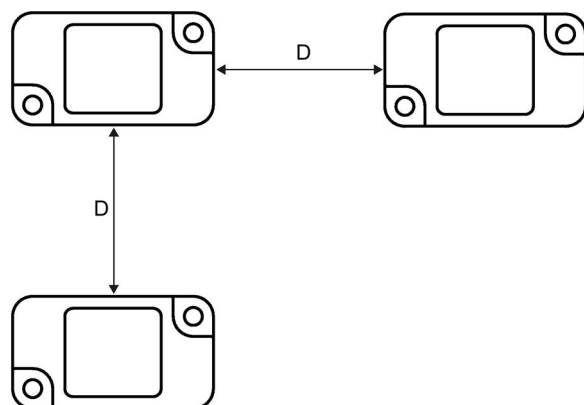

$$D \geq 150 \text{ mm}$$

Figure 6-7 Minimum distance for ANT 3

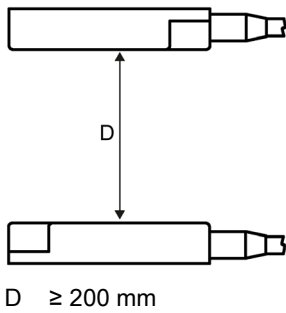

Figure 6-8 Face-to-face distance between two ANT 3s

6.2.6 Technical data

	6GT2398-1CD30-0AX0 6GT2398-1CD40-0AX0
Product type designation	ANT 3
Electrical data	
Maximum write/read distance ANT ↔ Transponder (S _g)	50 mm
Interfaces	
Plug connection	M8, 4-pin socket on antenna side (with antenna connecting cable: pin cable end)
Mechanical specifications	
Housing	
• Material	• Plastic PA6-V0
• Color	• Black
MTBF	13698 years
Permitted ambient conditions	
Ambient temperature	
• During operation	• -25 °C ... +70 °C
• During transportation and storage	• -40 °C ... +85 °C
Degree of protection to EN 60529	IP67
Shock according to EN 60721-3-7 Class 7 M3 ¹⁾	500 m/s ²
Vibration according to EN 60721-3-7 Class 7 M3 ¹⁾	200 m/s ²
Design, dimensions and weight	
Dimensions (L × W × H)	

6GT2398-1CD30-0AX0	
6GT2398-1CD40-0AX0	
• Housing without antenna connector	• 50 × 28 × 10 mm
• Housing with antenna connector	• 240 × 28 × 10 mm
Weight	
• Housing with antenna connector	• Approx. 35 g
• Housing with antenna connector and antenna cable	• Approx. 160 g
Type of mounting	2 x M4 screws
Cable length	3 m (plug-in antenna cable)

1) Warning: The values for shock and vibration are maximum values and must not be applied continuously.

6.2.7 Dimension drawing

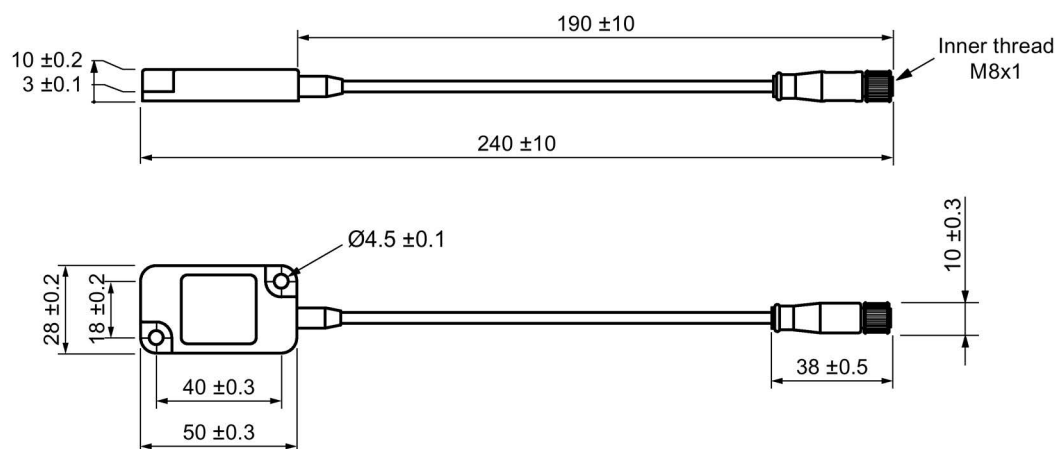



Figure 6-9 Dimension drawing ANT 3 (all values in mm)

6.3 ANT 8

6.3.1 Features

ANT 8	Characteristics	
	Area of application	Tool identification
	Writing/reading distance	up to 4 mm (depending on the transponder)
	Connecting cable	3 m
	Connectable readers	RF250R
	Degree of protection	IP67

6.3.2 Ordering data

Table 6- 9 Ordering data ANT 8

Antenna	Article number
ANT 8 (without antenna cable)	6GT2398-1CF00
ANT 8 (including one plug-in antenna cable 3 m)	6GT2398-1CF10

Table 6- 10 Ordering data ANT 8 accessories

Accessories	Article number
Antenna cable, 3 m	6GT2398-0AH30