

7.3 ASM 452

7.3.1 Features

Area of application

The ASM 452 interface module is a MOBY module for operating MOBY and RF300 components with RS422 over PROFIBUS DP-V1 on

- Any computers and PCs
- Any PLCs

When operating the interface module on a SIMATIC S7, function blocks are made available to the user.



Figure 7-6 Interface module ASM 452

The ASM 452 is the result of consistent development of the familiar ASM 450/451 interface modules. Optimal data throughput can be achieved even in large-scale PROFIBUS configurations thanks to the use of acyclic data traffic on PROFIBUS DP V1. The minimum cyclic data load of the ASM 452 on the PROFIBUS provides the user with the guarantee that other PROFIBUS nodes (e.g. DI/DO) can still be processed at great speed.

The ASM 452 is an interface module for communication between PROFIBUS and the RF310R with RS422 interface. Through the ASM 452, the data on the RF300 transponder can be physically addressed ("Normal" addressing). In SIMATIC S7, FC 45 is available for this purpose.

7.3.2 Pin assignment and display elements

Pin assignments

The figure below illustrates the pin assignments of ASM 452.

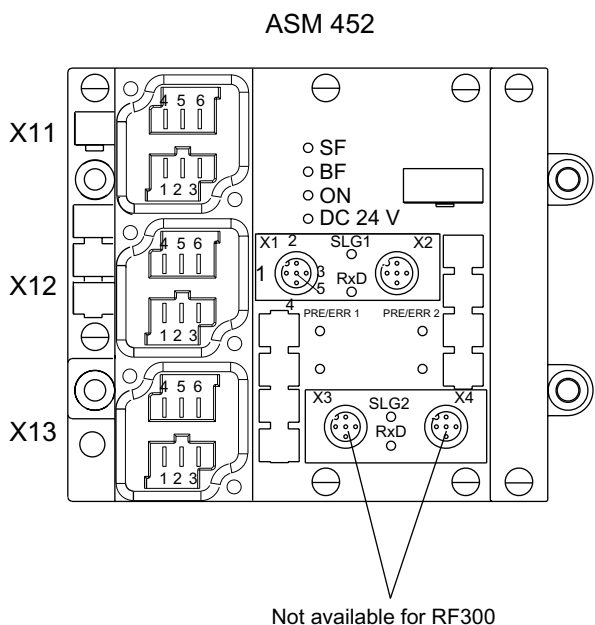

LEDs for PROFIBUS DP

SF: System Fault
 BF: Bus Fault

ON: Lights up when there is ASM (is generated by the 24 V supply voltage).
 24 V DC: Lights up when the 24 V supply voltage is connected to the ASM.

LEDs for RF300 and ASM 452

RxD: Reader active with
 PRE/ERR 1 Transponder present or error display
 (PRE/ERR 2) for reader
 (The "transponder present" display always takes priority. The error is only indicated when a transponder is not present.)

Transponder present: The LED is permanently ON. If more than one transponder is in the field, the number of transponders is indicated by short interruptions. A fault is not output.

Error display:

The LED is permanently OFF. The last error number is indicated by brief light pulses.

Reader 1: Reader 1 is selected
 (Reader 2) (Reader 2 is selected.)
 Only reader 1 can be selected.

Socket	Pin assignment
X11 and X12 (PROFIBUS DP)	1 Signal
	2 PE
	3* PE
	4 Signal
	5* L+
	6* M
X13 (Supply voltage)	1 PE
	2 L+
	3 M
	4 PE
	5 L+
	6 M

* Not connected

Socket	Pin assignment (reader)
X1 (X3) (green)	1 +RxD
	2 +TxD
	3 -TxD
	4 -RxD
	5 PE
X2 (X4)	X2 X4
	1 +24 V +24 V
	2 DA1 DE 1
	3 0 V 0 V
	4 DA0 DE 0
5 PE PE	

Figure 7-7 Pin assignment and LEDs of ASM 452

7.3.3 Configuration

Configuration

Hardware description

The ASM 452 has the same housing as the distributed I/O system ET 200X. General information on ASM 452 (e.g. assembly, operation and wiring; general technical data) is available in the ET200X manual (Order No. 6ES7 198-8FA00-8AA0). Descriptions of accessories and network components can also be found in this manual.

Configuration

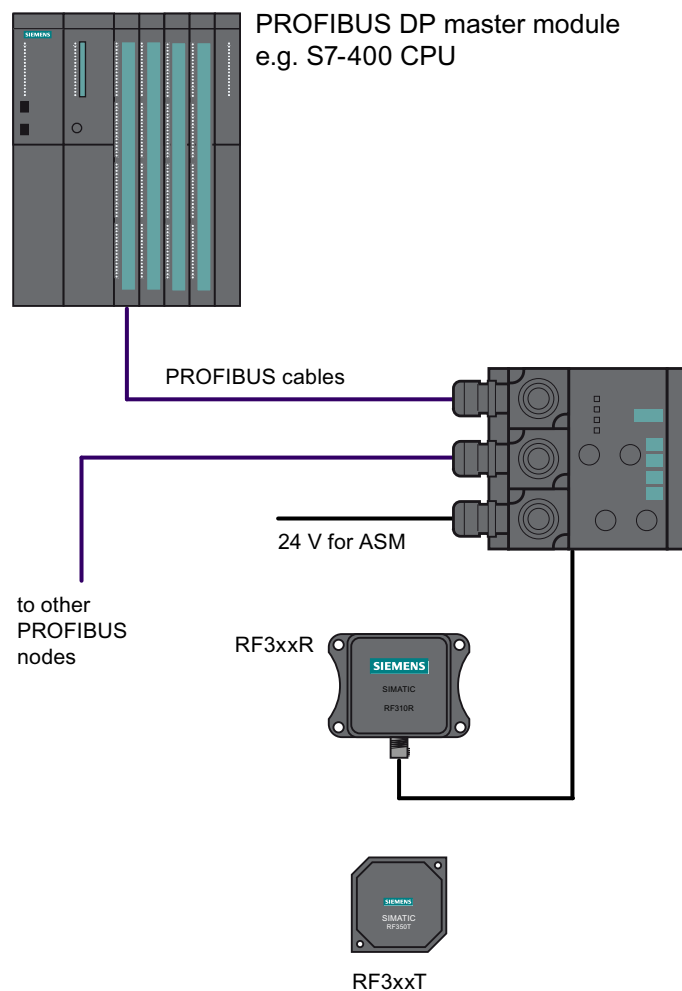

Figure 7-8 ASM 452 configurator

PROFIBUS configuration

The ASM 452 is integrated into the hardware configuration by means of a GSD file. The ASM can then be configured using the HW Config of SIMATIC Manager or another PROFIBUS tool.
 A GSD file is provided for ASM 452 on the CD "RFID Systems Software & Documentation".

Operating mode of the ASM 452

The approved operating modes of ASM 452 are described in the GSD file. It is set using the hardware configuration tool (e.g. STEP 7 HW Config).

Reader connection system

A reader always occupies two M12 connector sockets on the ASM 452.
 A pre-assembled cable therefore ensures easy connection of the reader (see figure below).
 The connecting cable is available in lengths of 2 m (standard) and 5 m. Extensions are possible up to 1000 m using connecting cables 6GT2891-... .

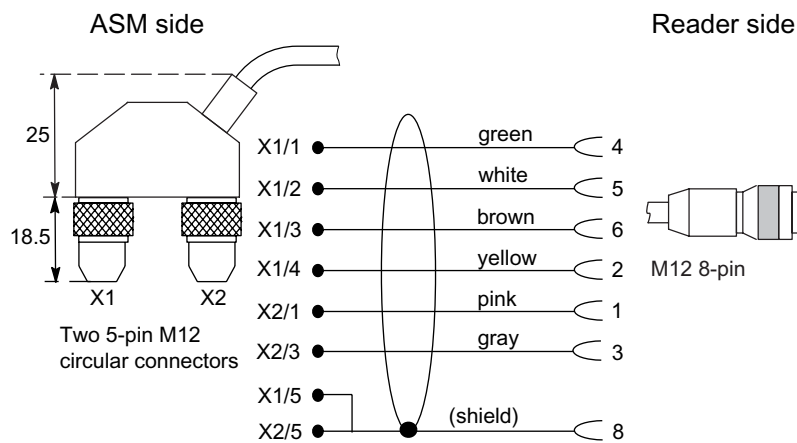

Figure 7-9 Connecting cable (2 m) ASM 452/473 ↔ RF3xxR reader with RS422 (6GT2891-1CH20)

Cable installation

Signal	M12 (reader side)	Cable	X1 / Data	X2
24 V DC	1	Pink	-	1
TX -	2	Yellow	4	-
GND	3	Gray	-	3
TX +	4	Green	1	-
RX +	5	white	2	-
RX -	6	brown	3	-
-			-	-
Shield	8 + terminal piece	Shield	5	5

Cable assignment ASM 452/473 ↔ RF3xxR reader with RS422 (6GT2891-1CH20)

A reader cable connector with screw-type terminals is provided for users who want to individually pre-assemble their own cables (see figure below). Cables and reader cable connectors can be ordered from the MOBY catalog.

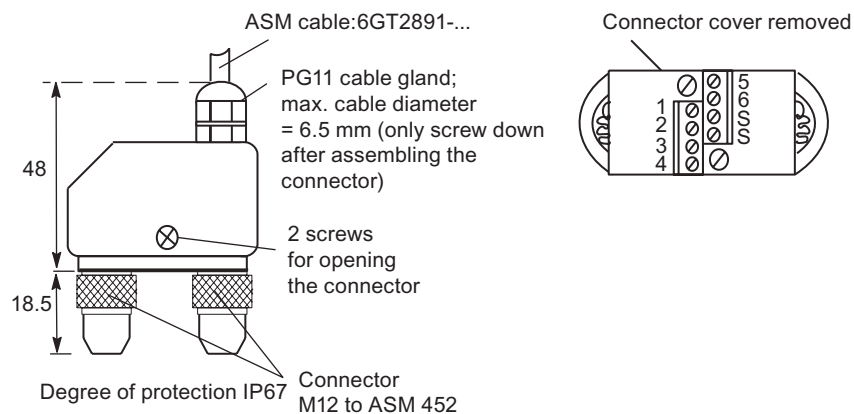

Figure 7-10 Cable connector ASM 452/473 ↔ RF3xx reader with RS422 (6GT2090-0BC00)

Pin assignment for ASM 452/473 cable connector

Connector pin	Connection to pin of the reader	Wire color
1	4	Note data sheet provided by the manufacturer
2	5	
3	6	
4	2	
5	3	
6	1	
	-	
S	8 + terminal piece	
Pin 7 must not be connected.		

PROFIBUS cable with 24 V supply

The ASM 452 can also be operated with the "green" PROFIBUS cable. It is important to ensure that a 24 V cable is connected from X12 to X13. The 24 V cable can be connected to pins 5 and 6 in plug X12.

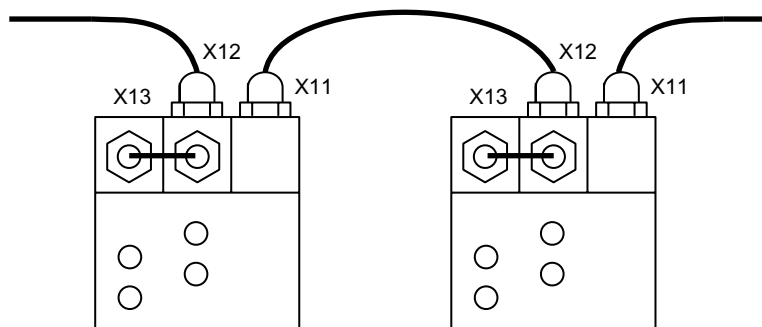

Figure 7-11 PROFIBUS cable with 24 V supply

PROFIBUS address and terminating resistor

You must remove the connector plate from the ASM before you set the PROFIBUS address or connect the terminating resistor. The connector plate covers the DIL switch. The position of the DIL switch in ASM is shown in the figure below with one setting example for each case.

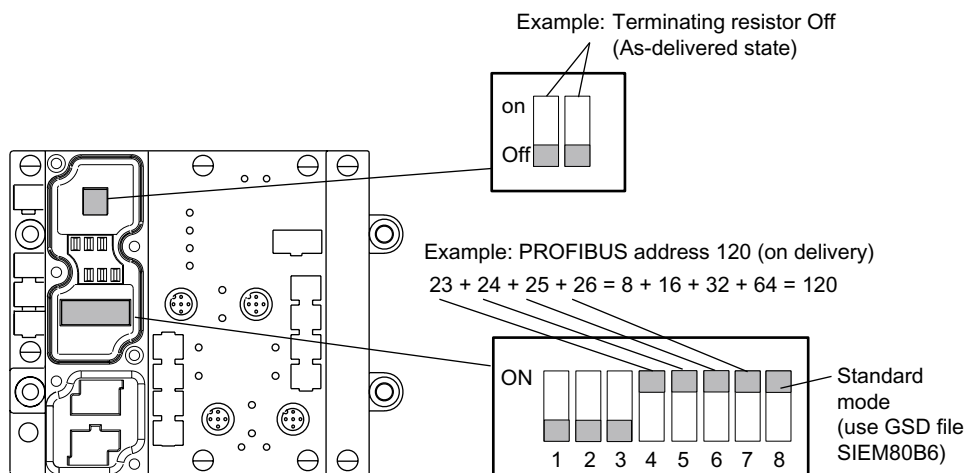

Figure 7-12 Setting the PROFIBUS address/connecting the terminating resistor

Note

- The PROFIBUS address in ASM 452 must always match the PROFIBUS address defined in the configuring software for this ASM.
- To ensure that the terminating resistor functions correctly, you must always switch **both** DIL switches of the terminating resistor to "on" or "off".

7.3.4 Technical data

Table 7-3 Technical data for ASM 452

ASM 452 with FC 45	
Serial interface to the user	PROFIBUS DP-V1
Procedure after connection	EN 50170 Vol. 2 PROFIBUS PG 11 cable gland PROFIBUS and power supply connectors are not included in the scope of delivery
Transmission rate	9600 baud to 12 Mbaud (automatic detection)
Max. block length	2 words cyclic/240 bytes acyclic
Serial interface to the RF3xxR	
Connector	2 x M12 coupler plug
Max. cable length	2 m = Standard length, 5 m, 10 m, 20 m and 50 m, (up to 1000 m on request)
Readers that can be connected	1x RF3xxR with RS422 interface
Software functions	
Programming	Depending on the PROFIBUS DP master
Function blocks for SIMATIC S7	FC 45
Transponder addressing	Direct access via addresses
Commands	Initialize transponder, read data from transponder, write data to transponder
Multi-tag capability	No
S7 data structures via UDTs	Yes
Power supply	
Rated value	24 V DC
Permissible range	20 V to 30 V DC
Current consumption	Max. 180 mA; typ. 130 mA (without reader)
Digital inputs	none
Digital outputs	None
Ambient temperature	
During operation	0 °C to +55 °C
Storage and transport	-40 °C to +70 °C
Dimensions (W x H x D) in mm	134 x 110 x 55 (without bus connector)
Fixing	4 M5 screws; for mounting on any plate or wall
Weight, approx.	0,5 kg
Degree of protection	IP67
MTBF (at 40 °C)	30 • 104 hours = 34 years

7.3.5 PROFIBUS Diagnosis

The following table lists possible error indications with their meanings and provides remedies.

Table 7-4 LED indication for PROFIBUS diagnosis

"BF" LED	"SF"LED	Cause of error	Error correction
ON	*	<ul style="list-style-type: none"> ASM 452 is in start-up mode. 	-
		<ul style="list-style-type: none"> The connection to the DP master has failed. ASM 452 not detecting a baud rate. 	<ul style="list-style-type: none"> Check the PROFIBUS DP connection. Check the DP master.
		<ul style="list-style-type: none"> Bus interrupt DP Master not functioning 	<ul style="list-style-type: none"> Check all cables on your PROFIBUS DP network. Check whether the connector plugs for PROFIBUS DP are securely plugged into the ASM 452.
flashes	on	<ul style="list-style-type: none"> The configuration data sent to the ASM 452 by the DP master do not match the configuration of the ASM 452. 	<ul style="list-style-type: none"> Check the configuration of the ASM 452 (input/output, PROFIBUS address). Correct GSD file being used? <ul style="list-style-type: none"> – SIEM80B6.GSD for ASM 452
Flashes	Off	<ul style="list-style-type: none"> ASM 452 has detected the baud rate, but is not being addressed by the DP Master. ASM 452 has not been configured. 	<ul style="list-style-type: none"> Check the PROFIBUS address set on the ASM 452 or in the configuration software. Check the configuration of the ASM 452 (station type).
on	Flashes	<ul style="list-style-type: none"> There is a hardware defect in the ASM 452. 	<ul style="list-style-type: none"> Replace the ASM 452.

7.3.6 Dimension drawing

The following figure shows the dimensional drawing of an ASM 452 with bus connectors. You must add the length of the PG cable gland and the radius of the cable used to the measured overall width and depth.

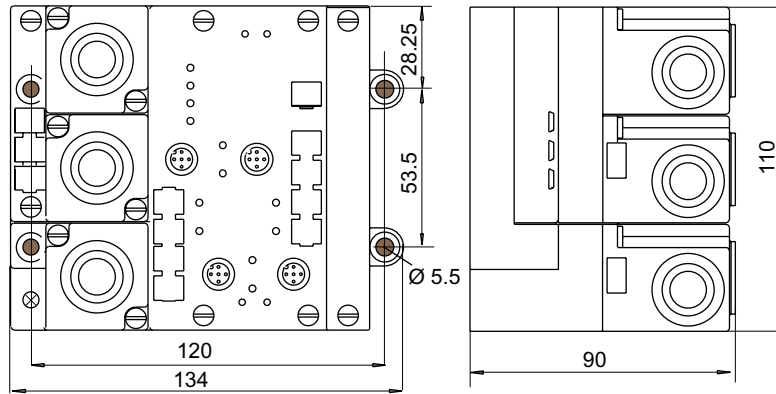

Figure 7-13 Dimensional drawing of ASM 452

Example of stripped lengths

The following diagram shows an example of stripped lengths. The lengths apply to all cables which can be connected to the connector plugs. You must twist any shield braid present, plug into a core end sleeve and cut off any excess.

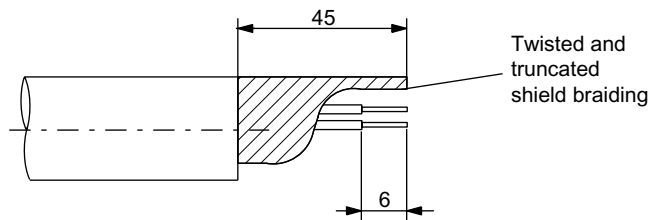

Figure 7-14 Length of stripped insulation for PROFIBUS cables

7.3.7 Ordering data

Table 7-5 Ordering data for ASM 452 and accessories

Product description	Order No.
ASM 452 interface module for PROFIBUS DP-V1, 1x RF3xxR with RS422 interface, without connector for 24 V DC and PROFIBUS	6GT2002-0EB20
Accessories:	
Connector for PROFIBUS DP and 24 V supply	6ES7194-1AA00-0XA0
Connecting cable RF3xxR ↔ ASM 452	
Plug-in cable, pre-assembled, length: 2 m (standard length)	6GT2891-1CH20
Plug-in cable, pre-assembled, length: 5 m	6GT2891-1CH50
Opt. Cable connector without read/write device cable (for cable lengths > 20 m) ASM 452 ↔ reader	6GT2090-0BC00
M12 blanking cap for unused RF310R connection (1 pack = 10 pieces)	3RX9802-0AA00
CD "RFID Systems Software & Documentation" with FC 45, GSD file	6GT2080-2AA10
Replacement part:	
Connector plate; T functionality for PROFIBUS connection	6ES7194-1FC00-0XA0
FC 45 Reference Manual German English French	Available in electronic form on the CD "RFID Systems Software & Documentation"

The ASM 456 plug-in cables 6GT2891-0Fxxx can be used as extension cables.

7.4 ASM 456

7.4.1 Description

Field of application

The ASM 456 interface modules are slave modules for operating RF300 components via the PROFIBUS DP/DP-V1 on any control systems.



Figure 7-15 Interface module ASM 456 with ECOFAST connection block or M12, 7/8"

When operating the interface module on a SIMATIC S7, convenient function blocks are made available to the user.

Features

The ASM 456 replaces the ASM 452 in terms of functionality and provides a simplified connection system. You can continue to use the user software from ASM 452. Optimum data throughput can be achieved through acyclic data traffic on the PROFIBUS DP V1 even when using large PROFIBUS configurations. The minimum cyclic data load of the ASM 456 on the PROFIBUS provides the user with the guarantee that other PROFIBUS consumers (e.g. DI/DO) can still be processed at great speed.

Up to 2 readers can be operated in parallel on the ASM 456. The user can start a command in parallel on 2 readers (via the corresponding FB/FC).

The transponder data are accessed by means of physical addressing of the reader. In SIMATIC S7, the FC 45 is available for this purpose. The FC 45 provides the S7 user with a simple-to-use interface with powerful commands (processing one complete transponder with one command; command linking; S7 data structures via UDTs).

Other features

- Degree of protection IP67
- System integration with ECOFAST or M12, 7/8" concept
- T functionality, that is, a component can be replaced without adversely affecting other modules with regard to bus communication and voltage supply
- Standardized PROFIBUS user interface for identification systems with PIB (Proxy Ident Function Block; with later firmware version).
- Firmware update
- PROFIBUS interface module up to 12 Mbaud with automatic baud rate detection
- Parameterizable device-related diagnostics data with text display
- Support for I&M functionality (a mechanism for reading out information via the module and saving system information such as function, installation date, installation location, and comments.)

Design

The ASM 456 has the same housing as the distributed I/O system ET 200eco.

The ASM has a connection block for connecting up to the PROFIBUS DP which is available as an option and the ECOFAST version or M12, 7/8".

The following figure shows the basic design of the ASM 456.

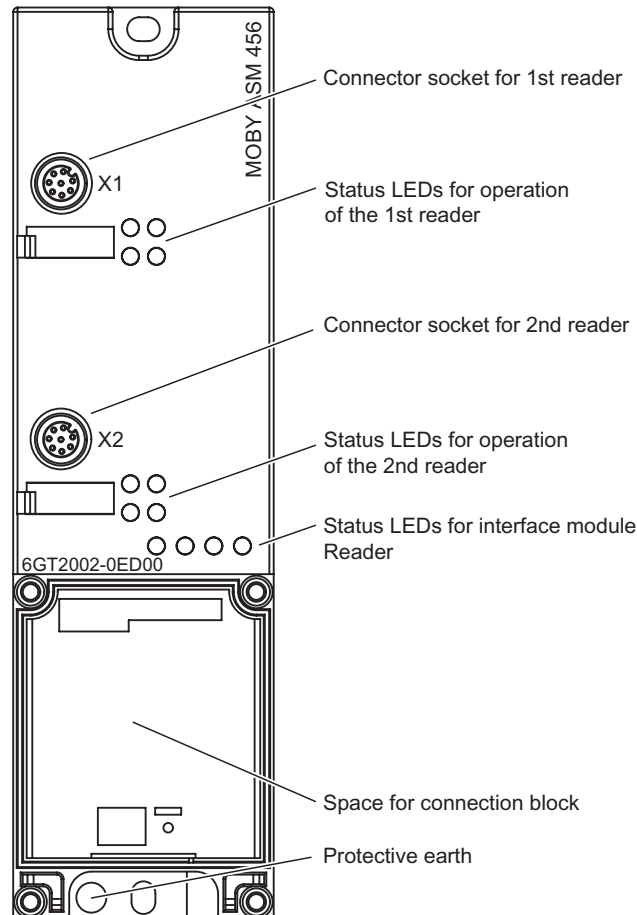

Figure 7-16 Basic design of the ASM 456

Configuration

The following figure shows how the ASM 456 is integrated in an automation system.

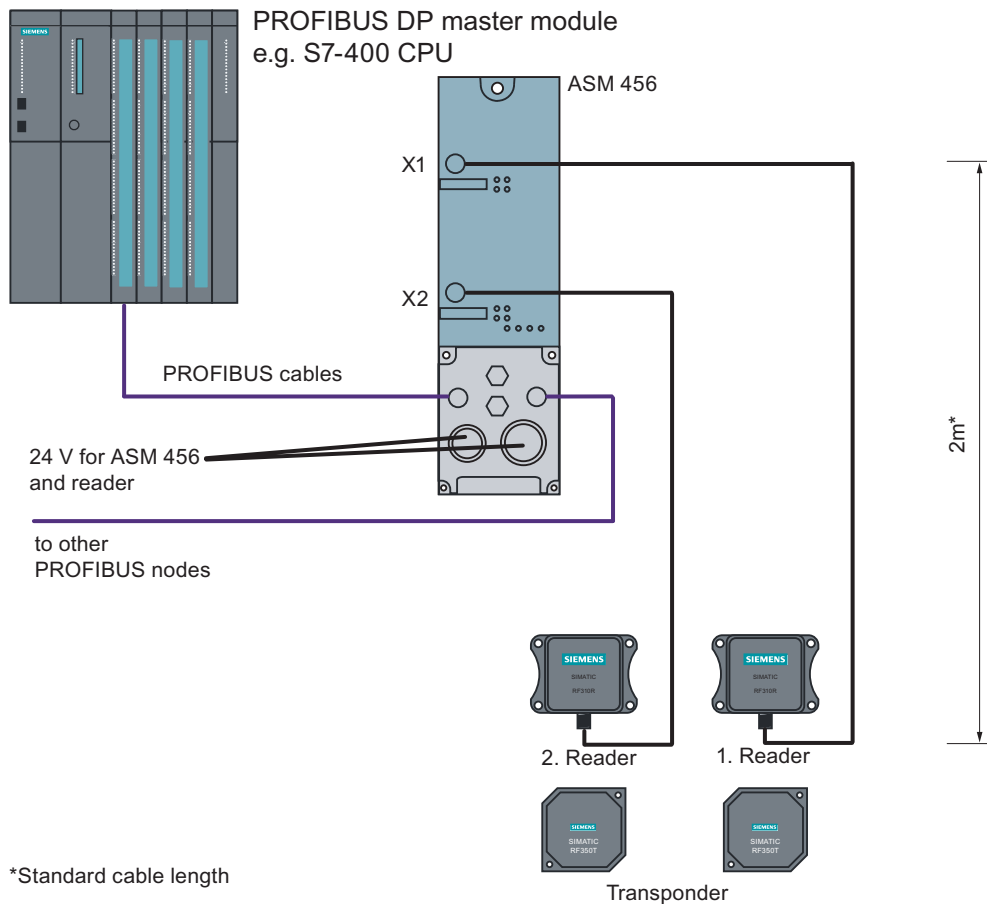

Figure 7-17 ASM 456 configurator

The ASM 456 is integrated into the hardware configuration by means of a GSD file. The ASM can then be configured using HW Config of SIMATIC Manager or another PROFIBUS tool (e.g. operating mode). The GSD file can be found on the "RFID Systems Software & Documentation" CD or on the Internet.

7.4.2 Setting the PROFIBUS address

Features

The PROFIBUS address defines the address at which the ASM 456 distributed I/O system is found on the PROFIBUS DP.

Requirements

- The PROFIBUS DP address for the ASM 456 is set on the connection block.
- Each address can be assigned only once on the PROFIBUS DP.
- The PROFIBUS address set must match the PROFIBUS address defined in the configuring software (for the ASM 456).
- Changes to the PROFIBUS DP address only take effect once the mains have been switched ON on the ASM 456.

Tools required for M12, 7/8" connection block

- Socket wrench 14 mm
- Screwdriver with 2.5 mm blade

Setting PROFIBUS DP addresses on connection block M12, 7/8"

Valid PROFIBUS DP addresses are 1 to 99.

1. Remove the two seal caps from the rotary switches (if necessary, use a 14 mm socket wrench).
2. Set the required PROFIBUS address on the rotary switches using a screwdriver.
 - Lower rotary switch: 1st position
 - Upper rotary switch: 10th position
3. Screw the two seal caps back onto the rotary switches (torque: 0.5 Nm to 0.8 Nm.)

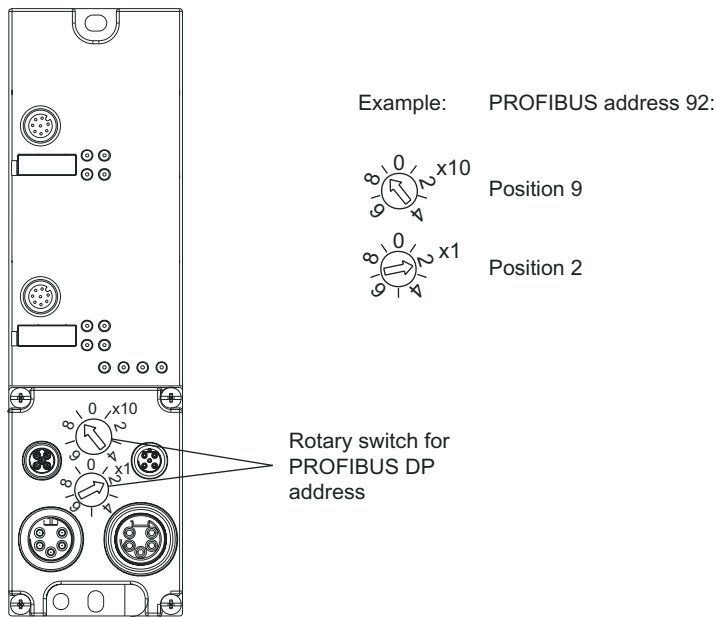

Figure 7-18 Setting PROFIBUS addresses on connection block M12, 7/8"

Setting PROFIBUS DP addresses on connection block ECOFAST

Valid PROFIBUS DP addresses are 1 to 99.

1. Loosen the screw connection of the configuration plug with the ECOFAST connection block and remove the plug.

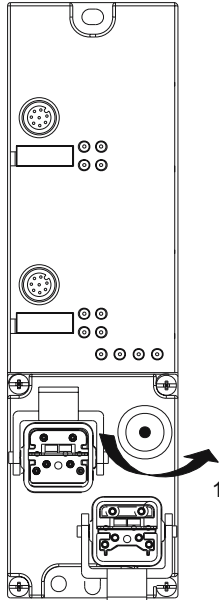

Figure 7-19 Loosening the configuration plug's screw connection

2. Loosen the screw connection for the cover cap on the configuration plug and remove the latter.
3. Set the PROFIBUS address using the DIL switches.

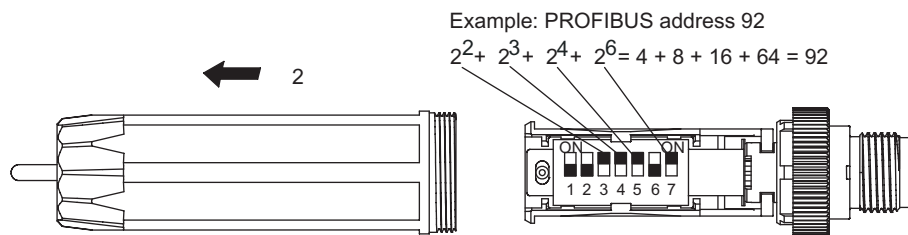

Figure 7-20 Setting PROFIBUS address on configuration plug

4. Screw the cover cap back down, plug the configuration plug onto the connection block and screw the configuration plug to the connection block.

7.4.3 Wiring up ASM 456

Wiring ECOFAST connector plugs

The table below contains the connector assignment for the ECOFAST connector plugs

Table 7-6 Connection assignment for ECOFAST connector plugs

Pin	Assignment	View of ECOFAST connector plug (wiring end for supply and loop-through connection)
A	PROFIBUS DP signal A	
B	PROFIBUS DP signal B	
1	Electronics / encoder supply (1L+) (voltage supply for ASM 456 and reader)	
2	Ground for electronic / encoder supply (1M)	
3	Ground for load voltage supply (2M)	
4	Load voltage supply (2L+) (unused on ASM 456)	
<p>*) You will find the assembly instructions in the packaging of the Han Brid Cu cable connector and/or Han Brid Cu cable socket.</p>		

Wiring M12, 7/8" connector

The tables below contain the connector assignment for the M12, 7/8" connector:

Table 7-7 Connection assignment for M12 connector (PROFIBUS DP)

Pin	Assignment	View of M12 connector (wiring side)
1	Supply positive (P5V2) *	
2	Data line A (RxD / TxD-N)	
3	Data reference potential (M5V2) *	
4	Data line B (RxD / TxD-P)	
5	Shield	
Thread	Shield	
*) Can only be used for the M12 terminating resistor. Looping the voltage through to the next connector via a 5-core cable is not permitted.		

Table 7-8 Terminal assignment of the 7/8" connector (supply voltages)

Pin	Assignment	View of 7/8" connector (wiring side)
1	Ground for load voltage supply (2M)	
2	Electronics/sensor supply ground (1M)	
3	PE	
4	Electronics / encoder supply (1L+) (voltage supply for ASM 456 and reader)	
5	Load voltage supply (2L+) (unused on ASM 456)	

Note

When connecting up the supply voltage, we recommend that the cable 6XV1 822-5B... (5 x 1.5 mm² pre-assembled with 7/8" connectors) is used.

If you want to assemble the cable yourself, then the conductor cross-section should be 1.5 mm².

Connecting the ASM 456 up to protective earth

1. Isolate the grounding cable and secure the cable lug.
2. Screw the cable lug down to the ASM 456 (M5 retaining bolt). The torque is 3 Nm.

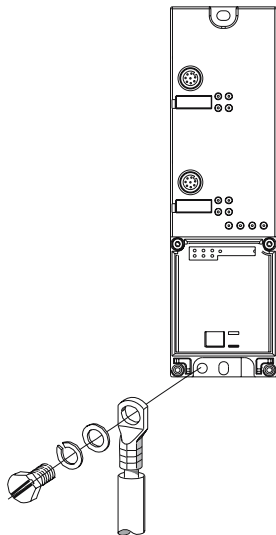

Figure 7-21 Connecting the ASM 456 up to protective earth

Connecting RF310 reader to ASM 456

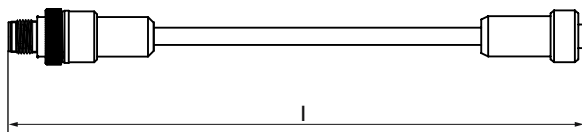

Figure 7-22 Connecting cable, l = 2 m, 5 m, 10 m, 20 m, 50m (6GT2891-0Fxxx)

Maximum cable length

The ASM 456 can be operated with any SLG configuration with a maximum cable length of 50 m.

Longer connecting cables of up to 1000 m are possible in some instances. The current consumption of the connected reader must however be taken into account. A number of cables must not be joined together to form a long cable due to the additional contact resistances.

Cable assembly by the customer

A reader connection plug with screw-type terminals is available for users who want to make their own cables.

Cables and reader cable connectors can be ordered according to the MOBY catalog.

For self-assembled cables, you will need cable to the following specifications:

7 x 0.25 mm²

LiYC11Y 7 x 0.25

M12 connectors can be purchased from appropriate electrical retailers (e.g. Binder in Germany).

The pin assignment is listed in the following table.

Table 7-9 Pin assignment

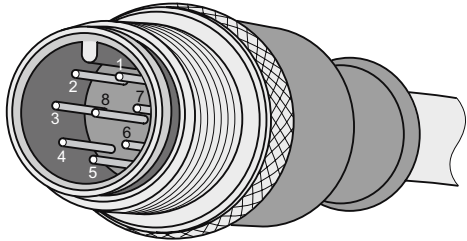
M12 connector (male)	Pin	Signal	Wire color
	1	+24 V	Note data sheet provided by cable manufacturer
	2	-RxD	
	3	0 V	
	4	RxD	
	5	TxD	
	6	-TxD	
	7	Free	
	8	PE / shield	

7.4.4 Diagnosis using LEDs

The following figure shows details of the LEDs of the ASM 456.

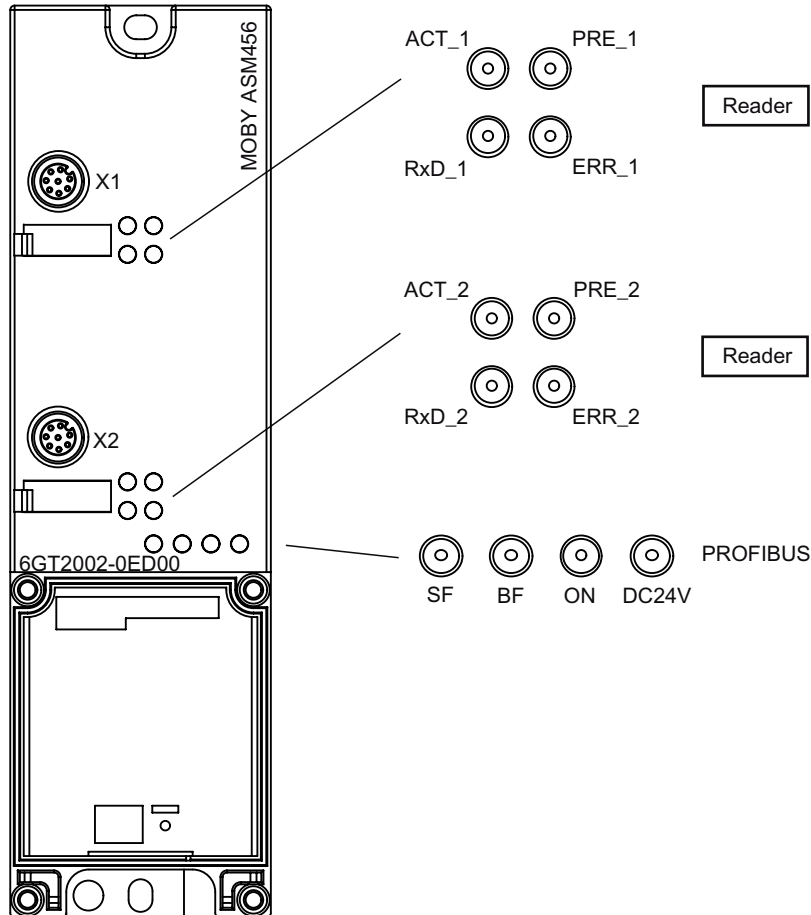

Figure 7-23 LEDs of the ASM 456

Table 7-10 Status LEDs for ASM 456

LEDs	Meaning*
ON	Lights up when there is logic voltage at the ASM (is generated by the 24 V supply voltage.)
24 V DC	Lights up when the 24 V supply voltage is connected to the ASM.
ACT_1, ACT_2	The corresponding reader is active in processing a user command.
ERR_1, ERR_2 *	A flashing pattern indicates the last error to occur.
PRE_1, PRE_2 **	Indicates the presence of a transponder.
RxD_1, RxD_2	Indicates live communication with the reader. May also indicate malfunctions on the transponder.
<p>*) The meaning of the individual flash patterns and the associated fault descriptions can be found in the relevant FB and FC documentation.</p> <p>**) In multitag mode, this LED uses a flash interval to indicate the number of data media currently within the range of influence of the reader.</p>	

Table 7-11 LED display for PROFIBUS diagnosis

BF	SF	Cause of error	Error handling
On	–	<ul style="list-style-type: none"> • ASM is in start-up mode. 	–
		<ul style="list-style-type: none"> • Connection to DP Master failed. • ASM not detecting a baud rate 	<ul style="list-style-type: none"> • Check the PROFIBUS DP connection. • Check the DP Master
		<ul style="list-style-type: none"> • Bus interrupt • DP Master not functioning 	<ul style="list-style-type: none"> • Check all cables on your PROFIBUS DP network. • Check whether the connector plugs for the PROFIBUS DP are securely plugged into the ASM.
flashes	On	<ul style="list-style-type: none"> • The project data sent to the ASM by the DP Master do not match the configuration of the ASM. 	<ul style="list-style-type: none"> • Check the project for the ASM (input/output, PROFIBUS address). • Correct GSD file being used?
flashes	–	<ul style="list-style-type: none"> • ASM has detected the baud rate, but is not activated by the DP Master. • ASM has not been assigned project plans. 	<ul style="list-style-type: none"> • Check the PROFIBUS address set in ASM and/or in the project software. • Check the project for the ASM (station type).
On	flashes	<ul style="list-style-type: none"> • There is a hardware defect in the ASM. 	<ul style="list-style-type: none"> • Replace the ASM.
Off	On	<ul style="list-style-type: none"> • Diagnosis available 	<ul style="list-style-type: none"> • Evaluate the diagnostic information.
On	Off	<ul style="list-style-type: none"> • The set PROFIBUS address is incorrect or greater than 99. 	<ul style="list-style-type: none"> • Set the address in the range 1 to 99 and carry out new ramp-up.
– = Status not relevant			

Other ASM operating modes are indicated by the PRE, ERR, ACT, SF and ON LEDs:

ON	SF	PRE_1	ERR_1	ACT_1	PRE_2	ERR_2	ACT_2	Description
On	Off	Off	Off	On	Off	Off	Off	Ramp-up active
Off	On	Off	On	Off	Off	Off	Off	Checksum error at ramp-up
Off	On	Off	Off	Off	Off	On	Off	Firmware invalid
On	On	On	On	On	On	On	On	LED test for approximately 4 seconds; otherwise firmware fault
Off	On	Off	On	On	Off	On	On	Checksum error at ramp-up
Off	On	On	On	On	Off	On	On	Checksum error of the firmware
Off	On	On	On	On	On	On	On	External RAM defective
Off	On	On	Off	On	On	On	On	DPC-RAM defective
Off	On	Off	On	On	On	On	On	ID error firmware
On	–	Off	1 x flash every 3 s	Off	Off	1 x flash every 3 s	Off	ASM successfully ramped up, waiting for reset command
On	–	–	Flashing	Rapid flashing	–	Flashing	Rapid flashing	Firmware update; alternate flashing of the error LEDs at approximately 1 Hz
– = not relevant								

7.4.5 Technical data

Table 7-12 Technical data for ASM 456

Serial interface to the user	PROFIBUS DP-V1
Procedure after connection	EN 50170 Vol. 2 PROFIBUS M12 and 7/8" technology / ECOFAST
Transmission rate	9600 baud to 12 Mbaud (automatic detection)
Max. block length	2 words cyclic/240 bytes acyclic
Serial interface to the reader	
• Connector	2 x M12 coupler plug
• Max. cable length	1000m, reader dependent; 2 m = Standard length; (up to 1000 m on request) Extension cable = 2 m, 5 m, 10 m, 20 m and 50 m
• Readers that can be connected	2 x reader
Software functions	
Programming	Depending on the PROFIBUS DP master
Function blocks:	
• SIMATIC S5	–
• SIMATIC S7	FC 45 (normal addressing without multitag)
Transponder addressing	Direct access via addresses
Commands	Initialize transponder, read data from transponder, write data to transponder, etc.
Supply voltage: ²	
• Rated value	24 V DC
• Permissible range	20 V to 30 V DC
Current consumption ¹	Max. 800 mA; typ. 80 mA (without reader)
Galvanic isolation	Yes
Ambient temperature	
• During operation	0 °C to +55 °C
• Storage and transport	–40 to +70 °C
Dimensions (W x H x D) in mm	
• ASM 456 only	60 x 210 x 30
• ASM 456 with ECOFAST connection block	60 x 210 x 60
Weight, approx.	210 g
Degree of protection	IP67
MTBF (at 40 °C)	122 years
1) The power supply must deliver the required current of up to 800 mA for brief power failures ≤ 20 ms.	
2) All supply voltages and signal voltages must be protective low level voltage (SELV/PELV acc. to EN 60950)	
24V DC supply: Safety (electrical) isolation of low voltage (SELV / PELV acc. to EN 60950)	

7.4.6 Dimension drawing

The following figure shows the dimensional drawing of an ASM 456 with bus connection block.

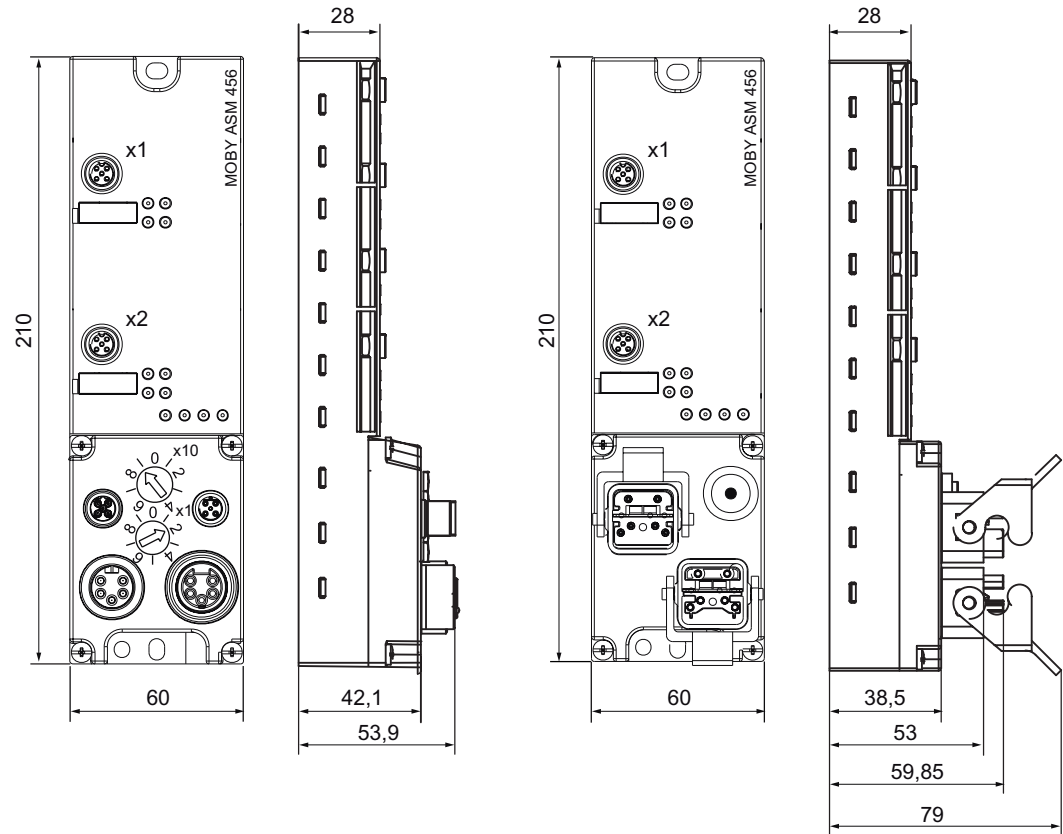

With connection block M12, 7/8"

With connection block ECOFAST

Figure 7-24 Dimensional drawing of ASM 456 (in mm)

7.4.7 Ordering data

Table 7-13 Ordering data for ASM 456 and accessories

Product description	Order No.
ASM 456 interface module for PROFIBUS DP V1 max. 2 readers can be connected	6GT2002-0ED00
Accessories for ECOFAST connection:	
Connection block ECOFAST	6ES7194-3AA00-0AA0
PROFIBUS ECOFAST hybrid plug 180	
with pin insert (5 per pack)	6GK1905-0CA00
with socket insert (5 per pack)	6GK1905-0CB00
PROFIBUS ECOFAST termination plug with terminating resistor	6GK1905-0DA10
ECOFAST hybrid cable, pre-assembled	6XV1830-7B... ¹⁾
ECOFAST hybrid cable, not pre-assembled, sold by the meter	6XV1830-7AH10
Accessories for M12 7/8" connection:	
Connection block M12	6ES7194-3AA00-0BA0
M12 terminal resistor for PROFIBUS (5 per pack)	6GK1905-0EC00
PROFIBUS cable with M12 connectors, pre-assembled	6XV1830-3D... ¹⁾
Cable for supply voltage with pre-assembled 7/8" connectors	6XV1822-5B... ¹⁾
PROFIBUS FC standard non-pre-assembled cable; max. length 1000 m	6XV1830-0EH10
PROFIBUS M12 connector plug (5 per pack)	
with pin insert	6GK1905-0EA00
with socket insert	6GK1905-0EB00
Connector plug 7/8" for voltage (5 per pack)	
with pin insert	6GK1905-0FA00
with socket insert	6GK1905-0FB00
Cable accessories:	
Plug-in cable, pre-assembled, length 2 m (standard length)	6GT2891-0FH20
Plug-in cable, pre-assembled, length 5 m	6GT2891-0FH50
Plug-in cable, pre-assembled, length 10 m	6GT2891-0FN10
Plug-in cable, pre-assembled, length 20 m	6GT2891-0FN20
Plug-in cable, pre-assembled, length 50 m	6GT2891-0FN50
Angled extension for direct connection of reader to ASM 456 or for extending any plug-in cables	6GT2891-0JH20
CD "RFID Systems Software & Documentation" with FC 45, GSD file	6GT2080-2AA10
Other accessories for ASM 456 (network components)	ET 200eco manual 6ES7198-8GA00-8AA0
Description of FC 45 (for ASM 456) German English French	Available in electronic form on the CD "RFID Systems Software & Documentation"

¹⁾ These cables are available in different lengths. See Catalog IK PI for more details

7.5 ASM 473

7.5.1 Features

Field of application

The ASM 473 interface module is an RF300 module for SIMATIC S7. It can be plugged into the ET 200X distributed I/O station and DESINA. ET 200X is operated by the user over PROFIBUS DP V1. An S7-300 or S7-400 with integrated PROFIBUS connection can be used as the controller.

ASM 473 supplements the SIMATIC S7 interface module ASM 475. The IP67 degree of protection means that it can be installed and operated in the process without the need for an additional protective housing.

To operate the ASM 473, an ET 200X basic module BM 141/142 with the order number 6ES7141-1BF11-0XB0 or 6ES7142-1BD21-0XB0 or a BM 143 is required.

The transponder data are accessed by means of physical addressing of the transponder.

For operation in a SIMATIC S7, the function FC 45 is available. The hardware of the ASM 473 is configured with an object manager (OM) that is integrated in the SIMATIC Manager.



Figure 7-25 Interface module ASM 473

Other features:

- Up to 7 ASM 473 interface modules can be operated simultaneously in an ET 200X station.
- Any other I/O modules from the ET 200X spectrum can be operated with the ASM 473.

7.5.2 Pin assignment and display elements

Pin assignments

The figure below illustrates the pin assignment for the read/write device and the display elements.

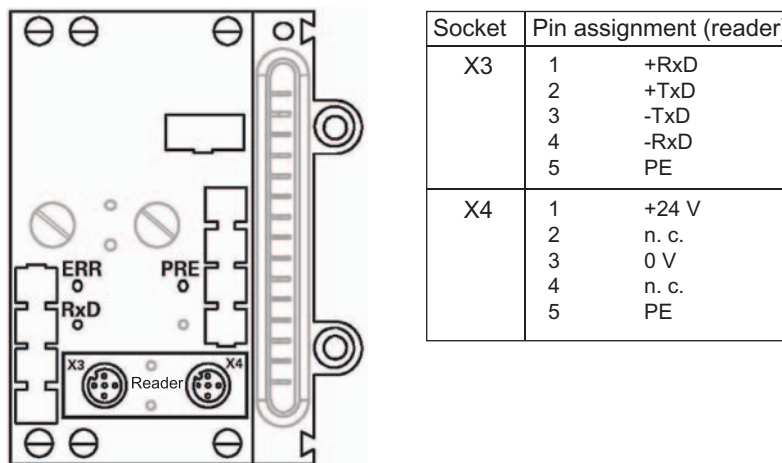

LEDs for PROFIBUS DP

General indicators (SF, BF, ON, 24VDC) are located on the basic module of the ET 200X.

LEDs for MOBY

- RxD: Reader active with command
- PRE: Indicates the presence of a transponder
- ERR: Error indicated by flashing sequence

The following ASM states are also indicated with the LEDs "PRE" and "ERR":

PRE	ERR	Description, Causes, Remedy
OFF/ON	ON (perm.)	Hardware is defective (RAM, flash,...)
ON	OFF	Charger is defective (can only be repaired in the factory).
2 Hz	OFF	Firmware loading is active or no firmware detected → Load firmware → ASM must not be switched off until loaded
2 Hz	2 Hz	Firmware loading terminated with errors → Restart required → Load firmware again → Check update files
5 Hz	5 Hz	Operating system error → Switch ASM or ET 200X base station OFF/ON
OFF	1 x flash every 2 s	ASM has booted and is waiting for a RESET (init_run) from the user

Figure 7-26 Interfaces and indicators of the ASM 473 for RF300

7.5.3 Configuration

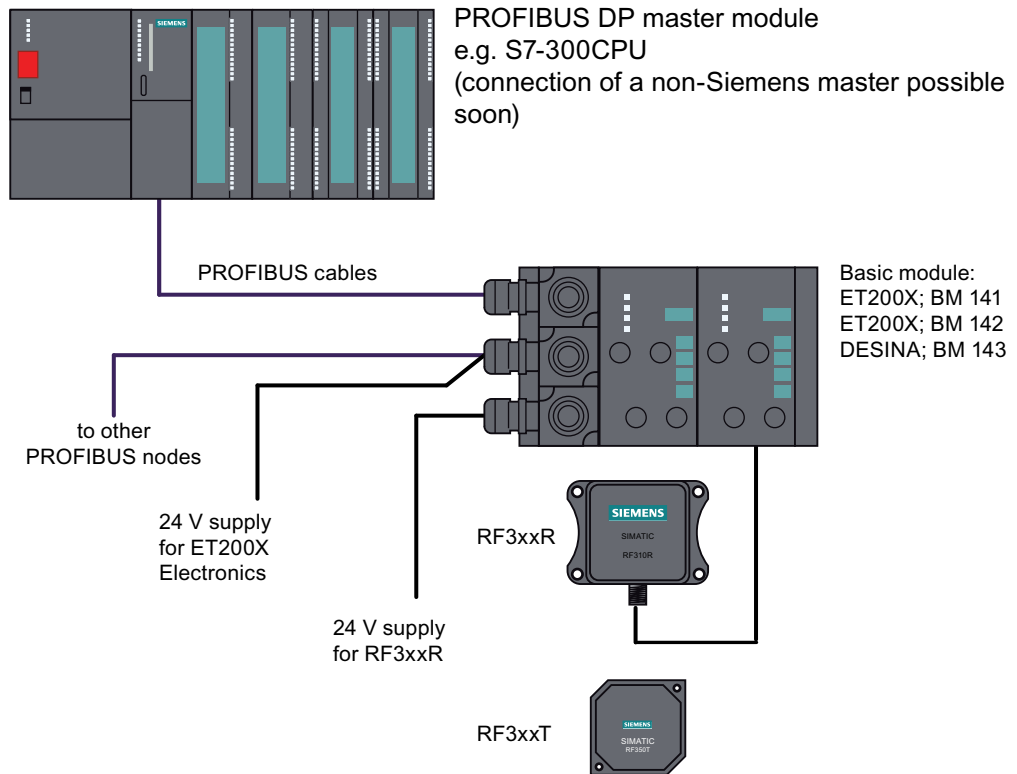

Figure 7-27 Example - Configurator for ASM 473

Note

It differs from ASM 452 in that for ET 200X the 24 V supply must be connected to the PROFIBUS connector **and** on the load voltage connector (see the ET 200X manual).

Basic module - Requirements for operation of ASM 473

The following table indicates the status of the ET 200X basic module of 10/2002. The functionality of new basic modules is stored in HW Config of the SIMATIC Manager.

Table 7-14 Requirements for operation of ASM 473

Order number of the ET 200X basic module	For operation with ASM 473 (6GT2002-0HA00)*	For operation with ASM 473 PARAM (6GT2002-0HA10)
6ES7141-1BF00-0XB0	No	No
6ES7141-1BF00-0AB0	Yes	Yes
6ES7141-1BF01-0XB0	No	No
6ES7141-1BF10-0XB0	No	No
6ES7141-1BF11-0XB0	Yes	Yes
6ES7141-1BF40-0AB0	Yes	Yes
6ES7142-1BD10-0XB0	No	No
6ES7142-1BD11-0XB0	No	No
6ES7142-1BD20-0XB0	No	No
6ES7142-1BD21-0XB0	Yes	Yes
6ES7142-1BD22-0XB0	No	Yes**
6ES7143-1BF00-0AB0	Yes	Yes
6ES7143-1BF00-0XB0	Yes	Yes
6ES7147-1AA00-0XB0	No	No
6ES7147-1AA01-0XB0	No	Yes
* Discontinued		
** Notes on operation: In HW Config, please parameterize the module 6ES7142-1BD21-0XB0.		

Example for a maximum configuration of ASM-473 on an ET 200X

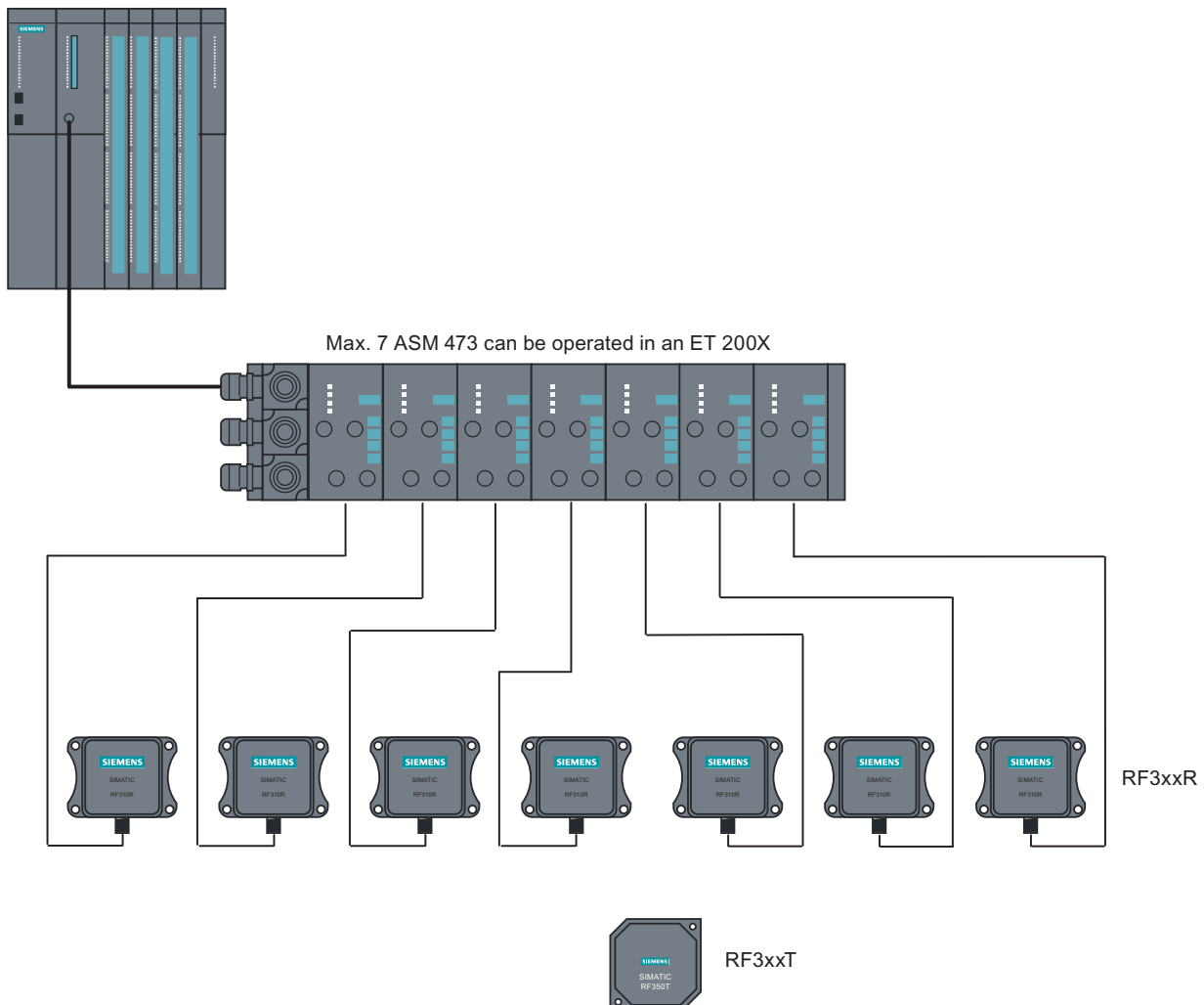

Figure 7-28 Example for a maximum configuration of ASM 473 on an ET 200X

Depending on the PROFIBUS master, up to 123 ET 200X modules can be run on one PROFIBUS branch.

Hardware configuration

The ASM 473 is integrated in the hardware configuration of the SIMATIC Manager by calling Setup.exe in the directory daten\S7_OM on the "RFID Systems Software & Documentation" CD. Currently, the ASM 473 cannot be integrated in masters of other manufacturers.

Reader connection system

A reader always occupies the two M12 connection sockets X3 and X4 on the ASM 473. A prefabricated cable makes it easy to connect the reader. The standard version of the connecting cable is 2 m in length. Other cable lengths are available on request. For customers who want to assemble their own cables, an ASM cable connector with screw-type terminals is available. Cables and ASM cable connectors can be ordered from the MOBY catalog.

7.5.4 Technical data

Table 7-15 Technical specifications for ASM 473

Interface for ET 200X	SIMATIC S7 I/O bus cyclic/acyclic services
Communication	2 words cyclic/238 bytes acyclic
Command buffer in ASM	142 x 238 bytes
Serial interface to the reader	
<ul style="list-style-type: none"> • Connector 	2 x M12 coupler plug
<ul style="list-style-type: none"> • Max. cable length 	2 m = standard length; other pre-assembled cables = 5 m, (up to 1000 m on request)
<ul style="list-style-type: none"> • Readers that can be connected 	1 x RF3xxR reader with RS422
Software functions	
Programming	Depending on the PROFIBUS DP master
Function blocks for SIMATIC S7	FC 45
MDS addressing	Direct access via addresses
Commands	Initialize transponder, read data from transponder, write data to transponder, etc.
PROFIBUS Diagnosis	Yes; in accordance with ET 200X basic station
S7 diagnostics	Yes, can be called up via S7 OM
Reloadable firmware	Yes, via S7 OEM
Power supply ¹	
<ul style="list-style-type: none"> • Rated value 	24 V DC
<ul style="list-style-type: none"> • Permissible range 	20.4 V to 28.8 V DC
Current consumption	Typ. 75 mA; max. 500 mA (or see Technical specifications of the connected reader)
Power dissipation of the module	Typically 1.6 W
Digital outputs/inputs	Via expansion modules from the ET 200X spectrum
Ambient temperature	
<ul style="list-style-type: none"> • During operation 	0 °C to +55 °C
<ul style="list-style-type: none"> • During transport and storage 	-40 °C to +70 °C
Dimensions (W x H x D) in mm	
<ul style="list-style-type: none"> • Single unit 	87 x 110 x 55
<ul style="list-style-type: none"> • Width module 	60 x 110 x 55
Fixing	2 M5 screws (customer side) 2 M3 screws (product side)
Degree of protection	IP67
Weight, approx.	0.275 kg

For installation instructions and general technical data, see the ET 200X manual.

7.5.5 Dimensional drawings

Dimension drawing for mounting holes

The figure below shows the dimensions for the position of the holes for the fixing screws for a basic module and an ASM 473 expansion module.

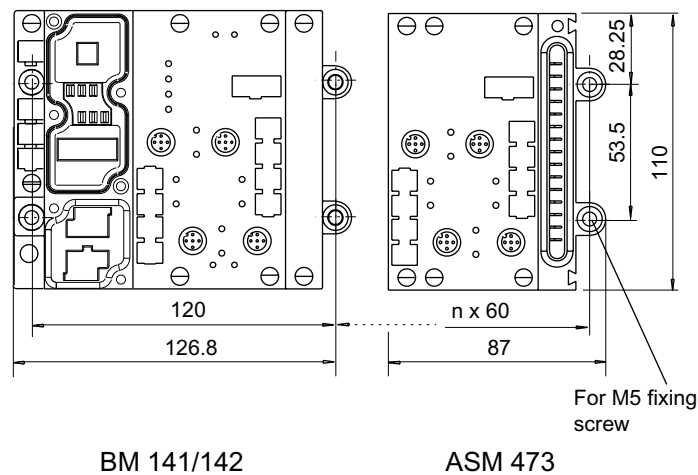

n = Number of expansion modules

Figure 7-29 Dimensions for fixing holes for basic modules and expansion modules

Example of stripped lengths

The following diagram shows an example of stripped lengths. The lengths apply to all cables which can be connected to the connector plugs. You must twist any shield braid present, plug into a core end sleeve and cut off any excess.

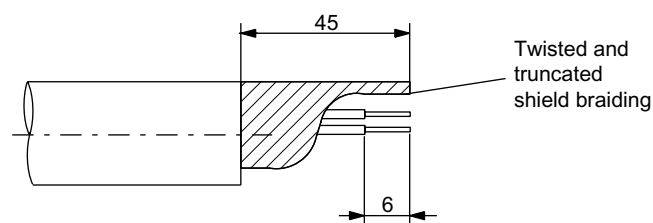

Figure 7-30 Length of stripped insulation for PROFIBUS cables

7.5.6 Ordering data

Table 7-16 Ordering data for ASM 473 and accessories

Product description	Order No.
Interface module ASM 473 1x RF3xxR reader with RS422 interface	6GT2002-0HA10
Accessories:	
Connecting cable ASM 473 ↔ Reader RF3xxR	
Plug-in cable, pre-assembled, length 2 m (standard length)	6GT2891-1CH20
Plug-in cable, pre-assembled, length 5 m	6GT2891-1CH50
Opt. Cable connector without reader cable (for cable lengths > 20 m) ASM 473 ↔ Reader	6GT2090-0BC00
CD "RFID Systems Software & Documentation" with FC 45, GSD file	6GT2080-2AA10
FC 45 Reference Manual German English French	Available in electronic form on the CD "RFID Systems Software & Documentation"

7.6 ASM 475

7.6.1 Features

Area of application

The ASM 475 interface module acting as the link between all RF300 systems and SIMATIC S7-300 performs the functions of a communication module. It can be operated centrally in the S7-300 or decentrally in an ET200M.

As many as eight ASM 475 interface modules can be plugged into one SIMATIC S7-300 rack and operated. In a configuration with several racks (max. four), the ASM 475 can be plugged into and operated on any rack. This means that as many as 32 ASMs can be operated in the maximum configuration of a SIMATIC S7-300. The ASM can also be operated in the ET 200M distributed I/O on PROFIBUS. Operation in an S7-400 environment is therefore problem-free. Up to 8 ASMs can be operated on each ET200M.

Error messages and operating states are indicated by LEDs.

A configuration that is resistant to interference is possible due to electrical isolation between the read/write device and the SIMATIC S7-300 bus.

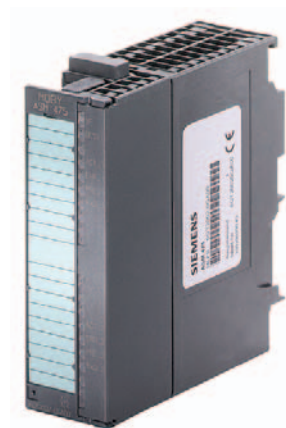

Figure 7-31 Interface module ASM 475

The ASM 475 with the order number 6GT2002-0GA10 is a parameterizable module. The basic functions of the module are then already specified when the module is configured in HW Config (e.g. standard addressing).

The data in the MDS is accessed direct by means of physical addresses using the ASM 475. Operation in a SIMATIC S7 is controlled by the function FC 45.

ASM 475 and FC 45 form a unit that is used for reading the data of the MDS easily and at optimal speed.

7.6.2 Indicators

Bezel and indicator elements

The figure below illustrates the bezel of the ASM 475 and the inside of the front door complete with the associated connection diagram. The read/write devices must be connected to the ASM in accordance with the connection diagram.

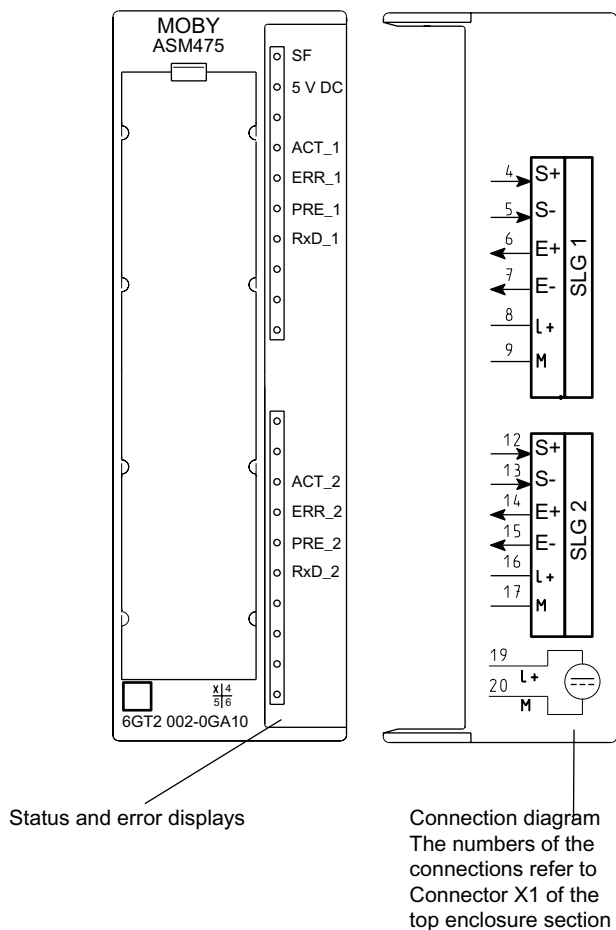

Figure 7-32 Bezel and inside of the front door of the ASM 475

Display elements on the ASM

Table 7-17 Function of the LEDs on the ASM 475

Light emitting diode	Meaning
SF	System fault (hardware error on ASM)
DC 5V	24 V are connected to ASM and the 5 V voltage on ASM is OK.
ACT_1, ACT_2	The corresponding reader is active in processing a user command.
ERR_1, ERR_2	A flashing pattern indicates the last error to occur. This display can be reset using the parameter Option 1.
PRE_1, PRE_2	Indicates the presence of a transponder.
RxD_1, RxD_2	Indicates live communication with the reader. In the event of a fault on the reader, this display may also be lit.

On the ASM 475, further operating states are indicated with the LEDs PRE, ERR and SF:

Table 7-18 Operating status display on ASM 475 via LEDs

SF	PRE_1	ERR_1	PRE_2	ERR_2	Meaning
ON	OFF/ON	ON (perm.)	OFF/ON	ON (perm.)	Hardware is defective (RAM, Flash, etc.)
ON	OFF	ON	OFF	OFF	Charger is defective (can only be repaired in the factory).
OFF	2 Hz	OFF	2 Hz	OFF	Firmware loading is active or no firmware detected <ul style="list-style-type: none"> Firmware download ASM must not be switched off
OFF	2 Hz	2 Hz	2 Hz	2 Hz	Firmware loading terminated with errors <ul style="list-style-type: none"> Restart required Load firmware again Check update files
Any value	5 Hz	5 Hz	5 Hz	5 Hz	Operating system error <ul style="list-style-type: none"> Switch ASM off/on
OFF	OFF	1 flash every 2 s	OFF	1 flash every 2 s	ASM has booted and is waiting for a RESET (init_run) from the user.

7.6.3 Configuration

Centralized configuration with SIMATIC S7-300

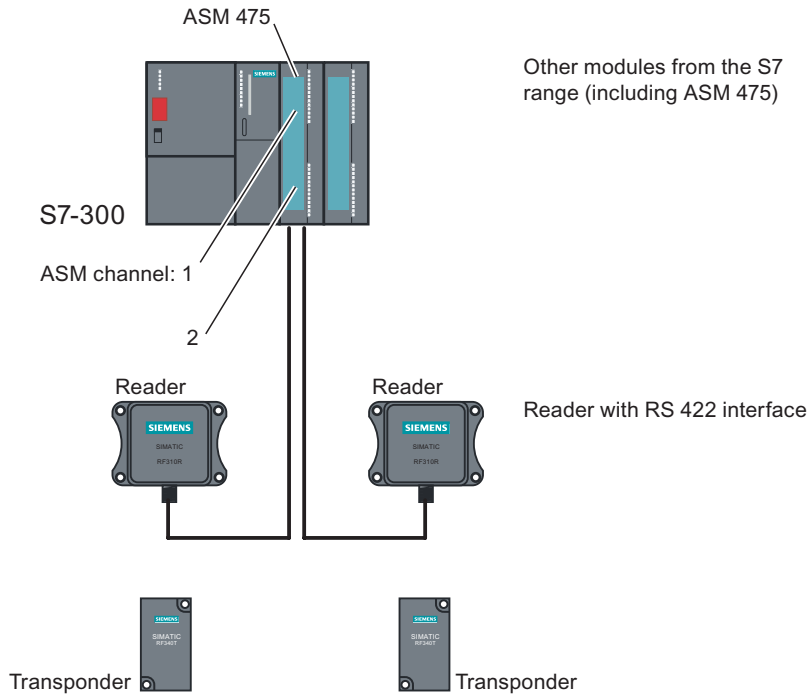

Figure 7-33 Configurator for ASM 475 with RF310R reader (centralized configuration)

Distributed configuration with ET200M

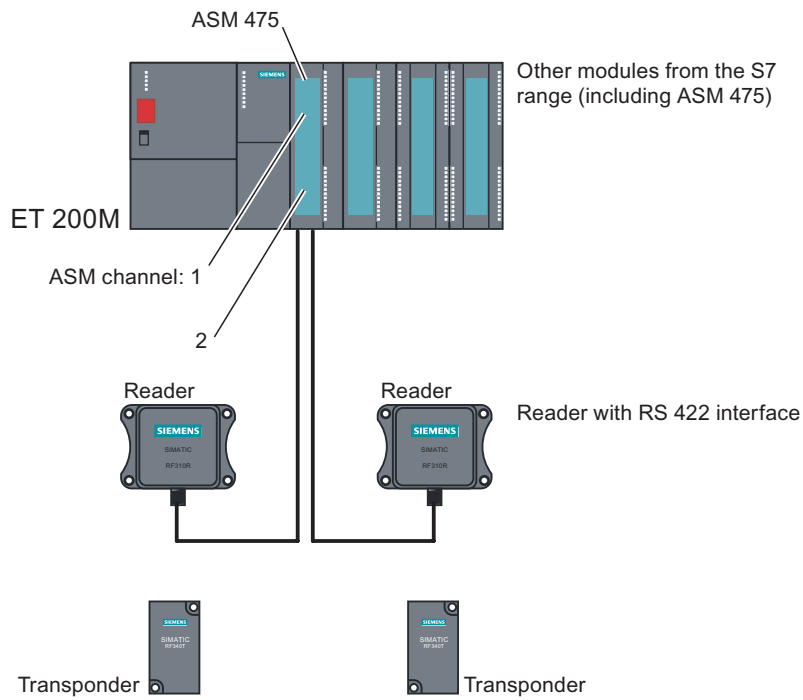
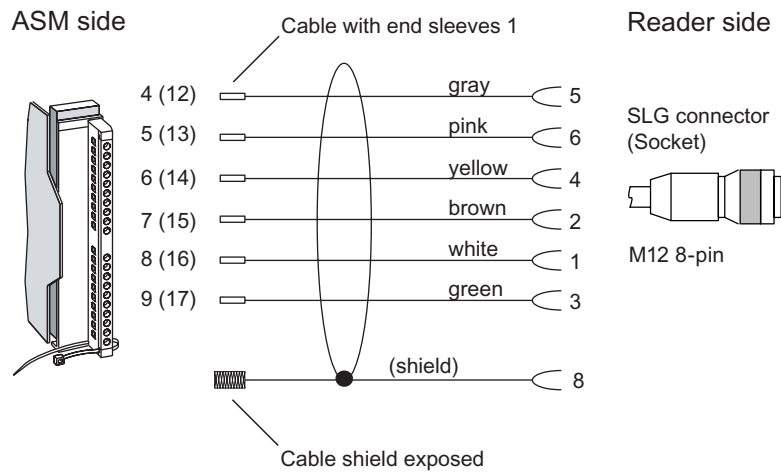

Figure 7-34 Configurator for ASM 475 with RF310R reader (distributed configuration)

Reader connection system



¹ 6GT2891-0E... with straight SLG connector (standard)

Figure 7-35 Installation of connecting cable between ASM 475 and RF300 reader with RS 422

Cable installation

Signal	Pin on M12 connector	Cable	Labeling
24 V DC	1	white	1 Reader 2 8 -16
TX -	2	brown	1 Reader 2 7-15
GND	3	Green	1 Reader 2 9-17
TX +	4	Yellow	1 Reader 2 6-14
RX +	5	Gray	1 Reader 2 4-12
RX -	6	Pink	1 Reader 2 5-13
Shielding	8 + terminal piece	-	

Cable assignment for connection of an RF300 reader to ASM 475

7.6.4 Technical data

Table 7-19 Technical data for ASM 475

ASM 475 with FC 45	
Serial interface for SIMATIC S7-300 or ET200M	I/O bus; cyclic and acyclic services
Communication	2 words cyclic/238 bytes acyclic
Command buffer in ASM 475	70 x 238 bytes per RF310R reader
Serial interface to the reader	
Connector	Via screw-type terminal on front connector The front connector is not included in the scope of supply.
Max. cable length	Pre-assembled cables = 2 m, 5 m, (up to 1000 m on request)
Readers that can be connected	2 x RF3xxR reader with RS422 parallel mode
Software functions	
Programming	Depending on the PROFIBUS DP master
Function blocks for SIMATIC S7	FC 45
Transponder addressing	Access directly via addresses
Commands	Initialize transponder, read data from transponder, write data to transponder
Multitag mode	No
S7 data structures via UDTs	Yes
Power supply	
Rated value	24 V DC
Permissible range	20.4 V to 28.8 V DC
Current consumption	
Without reader for U = 24 V DC, max.	350 mA
With reader connected, max.	500 mA, per connected reader
Power dissipation of the module, typ.	2 Watts
Current consumption from I/O bus, max.	80 mA
Electrical isolation between S7-300 and RF300	Yes
V24 fuse to reader	Yes, electronic
Ambient temperature	
During operation	
Horizontal installation of SIMATIC	0 to +60 °C
Vertical installation of SIMATIC	0 to +40 °C
Transport and storage	-40 up to +70 °C
Dimensions (W x H x D) in mm	40 x 125 x 120
Weight, approx.	0,2 kg

7.6.5 Ordering data

Table 7-20 Ordering data for ASM 475 and accessories

Product description	Order No.
ASM 475 interface module for SIMATIC S7 2 x RF3xxR reader with RS422 can be connected in parallel, without front connector	6GT2002-0GA10
Accessories:	
Front connector (1 x per ASM)	6ES7392-1AJ00-0AA0
Connecting cable ASM 475 ↔ RF3xxR	
Plug-in cable, pre-assembled, length: 2 m (standard length)	6GT2891-0EH20
Plug-in cable, pre-assembled, length: 5 m	6GT2891-0EH50
Terminal element (1 x per reader cable)	6ES7390-5BA00-0AA0
Shield connecting element	6ES7390-5AA00-0AA0
CD "RFID Systems Software & Documentation" with FC 45, S7 object manager	6GT2080-2AA10
FC 45 Reference Manual German English French	Available in electronic form on the CD "RFID Systems Software & Documentation"

The ASM 456 plug-in cables 6GT2891-0Fxxx can be used as extension cables.

7.7 RF170C

7.7.1 Description

Area of application

The RF170C communication module is a SIMATIC S7 module. It can be plugged into the ET 200pro distributed I/O device. The ET 200pro is operated by the user over PROFIBUS DP-V1 or PROFINET IO. An S7-300 or S7-400 with integrated PROFIBUS/PROFINET connection can be used as the controller.

The ET 200pro with RF170C can communicate with all DP masters compliant with the IEC 61784-1:2002 Ed1 CP 3/1 standard. The DP master must support DP-V1 (acyclic services).

RF170C can be used as a central I/O in an ET 200pro with IM 154-8 CPU. Thanks to its degree of protection IP67, the RF170C can be installed and operated direct at the process without any additional protective housing.



Figure 7-36 RF170C communication module

When operating the communication module on a SIMATIC S7, convenient function blocks are made available to the user.

The following RFID systems can be operated with the RF170C:

- MOBY D
- MOBY U
- RF300
- MOBY E
- MOBY I

Features

Operation of the RF170C requires an ET 200pro interface module (IM 154-1 DP, IM 154-2 DP High Feature, IM 154-4 PN High Feature, IM 154-8 CPU).

Via the RF170C: the data on the transponders can be

- physically addressed (normal addressing) or
- addressed by means of a DOS-like file management system (filehandler).

Functions are available in SIMATIC S7 for both access methods:

- FC 45/FB 45 and FC 55 for normal addressing
- FC 56/FB 56 for filehandler

The functions provide the S7 user with an interface with powerful commands that is easy to operate. In addition, the functions offer command chaining and S7 data structures via UDTs.

The hardware of the RF170C is configured with an object manager (OM) integrated into the SIMATIC Manager, or with the GSD file.

Other features

- Up to 9 RF170Cs can be operated simultaneously in one ET 200pro station.
- Any other I/O modules from the ET 200pro spectrum can be operated with the RF170C.
- Degree of protection IP67
- Integration into the plant with standard cables or user-assembled cables using ECOFAST, M12, 7/8" or direct connection (heavy-gauge threaded joint)
- T functionality, that is, a component can be replaced without adversely affecting the bus communication and voltage supply of the other modules
- Standardized PROFIBUS user interface for identification systems with RFID standard profile (available soon)
- Firmware update of the RF170C is
 - possible via PROFIBUS DP
 - possible via IM 154-8 CPU
 - not currently possible via PROFINET IO
 - not possible via GSD file
- Parameterizable diagnostics data
- Support for I&M functionality

(I&M is a mechanism for reading out information via the module and saving system information such as function, installation date, installation location, and comments).

Design

The ET 200pro is designed for rack mounting and always features

- an interface module which transfers data to the DP master or IO controller,
- or a CPU,
- up to 9 RF170C modules,
- connection modules in various designs for
 - interface modules (PROFIBUS DP, PROFINET IO, power supply)
 - Communication modules

You can thus set the focus of your configuration on local requirements.

The comfortable handling features of ET 200pro ensure quick commissioning and easy maintenance.

Note

A tool called *SIMATIC ET 200 Configurator* is available for configuring the ET 200pro.

You will find the tool on the Internet at:

<http://www.siemens.com/automation/service&support>

Search for the entry with the number 22614936.

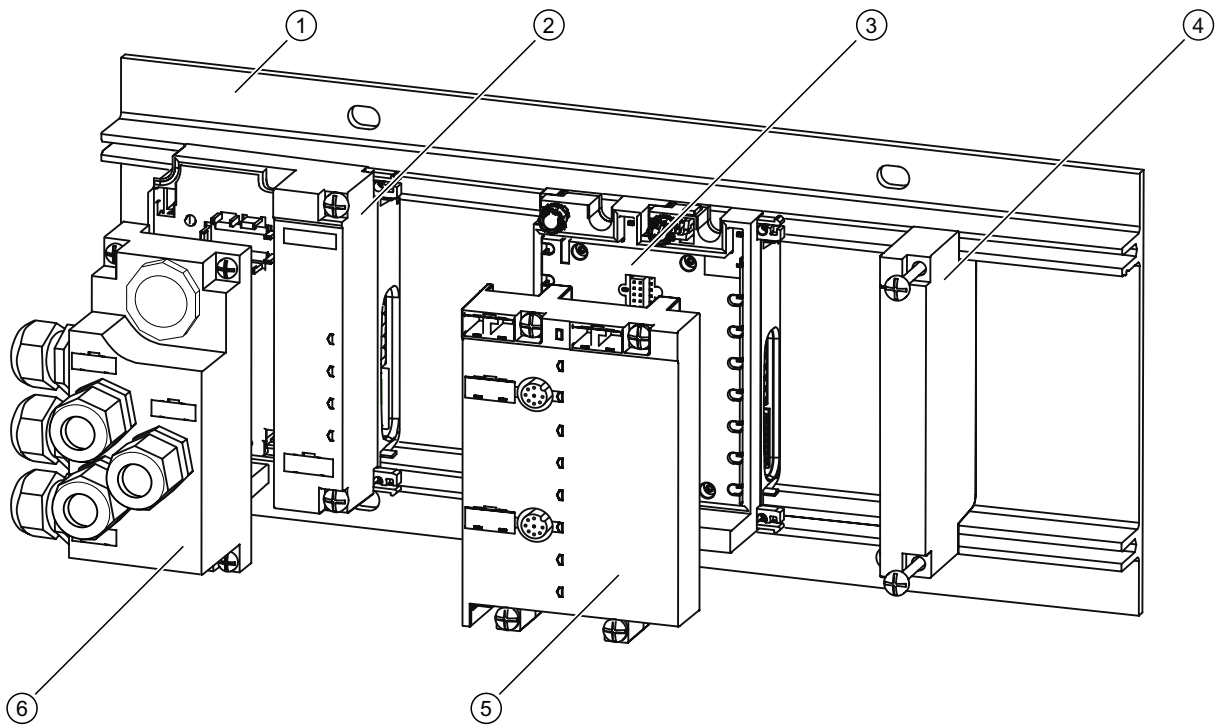

Figure 7-37 ET 200pro with RF170C

- ① Rack
- ② Interface module with bus module
- ③ RF170C communication module (comprising electronic module and bus module)
- ④ Terminating module
- ⑤ RF170C connection module
- ⑥ Connection module for interface module

An IM 154-8 CPU can also be inserted as interface module.

Configuration

Note

In the figures below, the ET 200pro with the CM IM DP Direct connection module represents an example for the interface module.

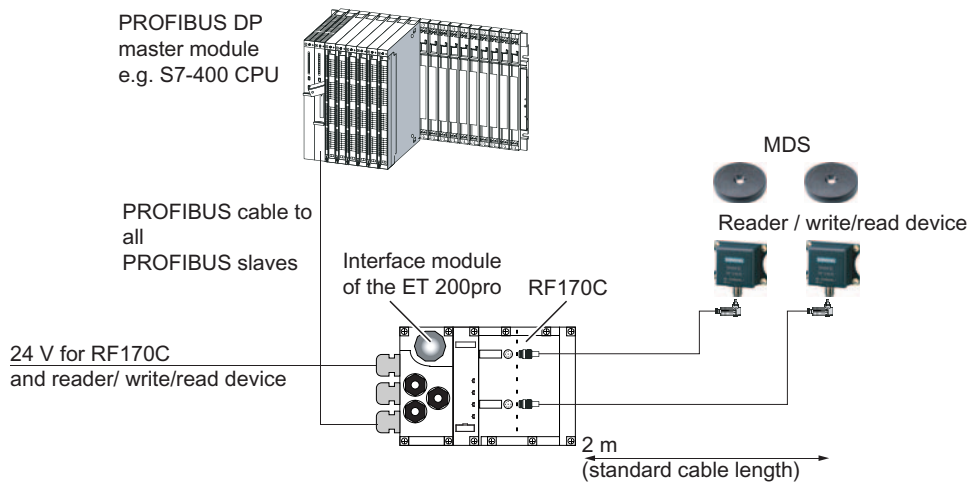

Figure 7-38 Configurator for an RF170C

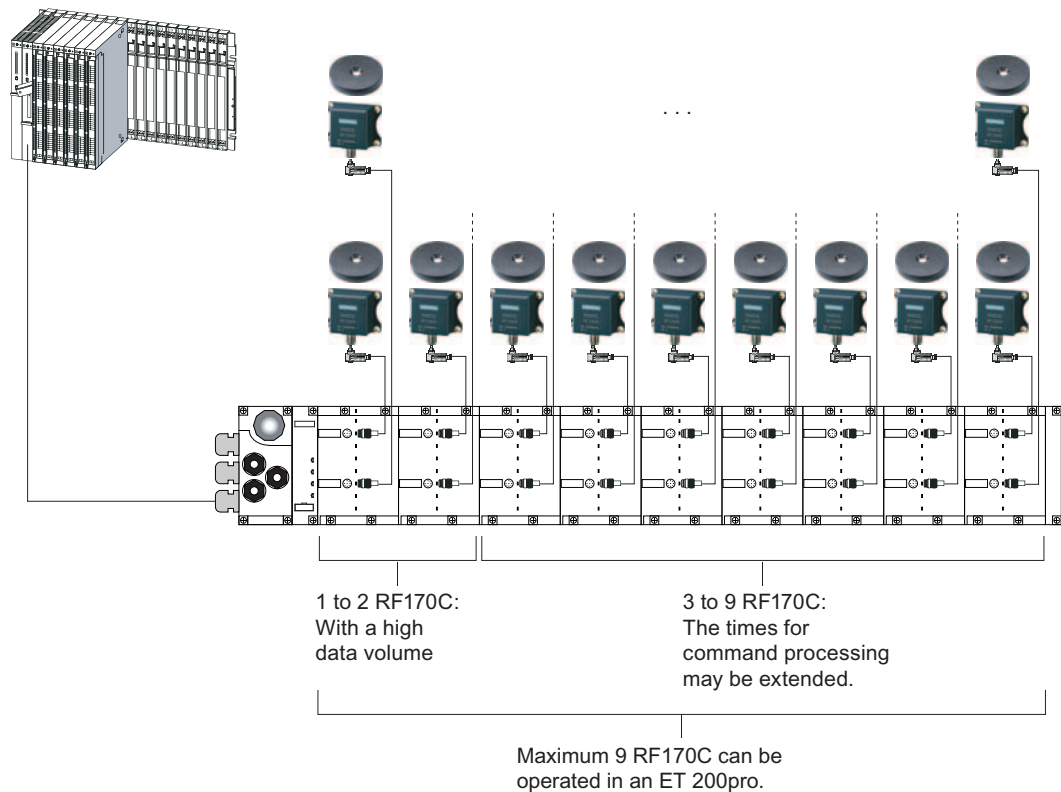

Figure 7-39 Maximum configuration of RF170C on an ET 200pro

7.7.2 Connect the RF170C with the connection module

Introduction

On the RF170C connection module, you connect the cable to the readers / write/read devices using 8-pin round sockets. Use an 8-pin M12 connector and a corresponding cable if you prefer to produce a customized cable. In doing so, please comply with the cable configurator in the system manuals of the RFID families.

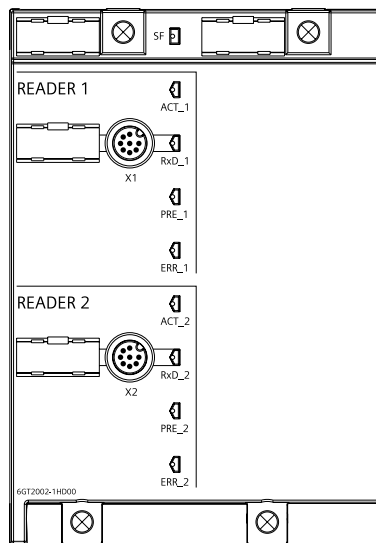

Figure 7-40 Sockets and LEDs of the RF170C connection module

Requirements

Before you start to wire the RF170C connection module, switch off the supply voltage, or de-install the connection module.

Note

It is easier to wire the RF170C connection module after you have removed it from the communication module.

Accessories required for the RF170C

- Patch cable with 8-pin M12 connector
- Alternatively: Shielded 7-core Cu cable, flexible, conductor cross-section $\leq 0.75 \text{ mm}^2$ and 8-pin M12 connector

Connecting M12 connectors

1. Plug the connector into the relevant socket of the RF170C connection module. Make sure the connector and socket are properly interlocked (groove and spring).
2. Tighten the knurled screws of the connector (torque = 1.5 Nm.)

Connect RF170C connection module

1. Insert the RF170C connection module into the communication module.
2. Screw the connection module onto the rack (4 cross-head screws on the front: top and bottom, tightening torque 1.5 Nm)

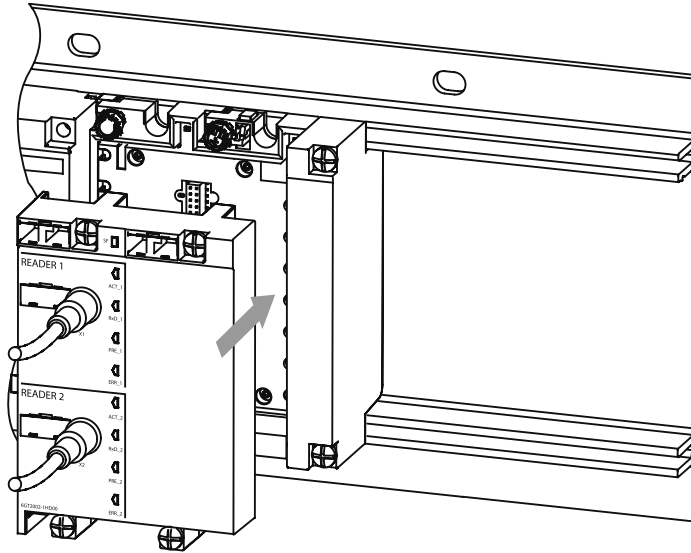

Figure 7-41 Connect RF170C connection module

Sealing unused sockets

Always close all unused sockets using M12 caps in order to achieve the degree of protection IP65, IP66 or IP67.

Reference

ET 200pro Distributed I/O device operating instructions, Section Electrical configuration of ET 200pro

7.7.3 LED displays on the RF170C communication module

LED display

The figure below shows the position and layout of the LED display on the the RF170C connection module.

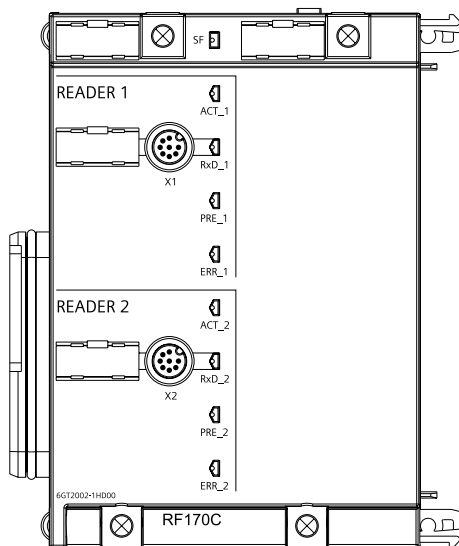

Figure 7-42 LED display on the RF170C communication module

Status and error LEDs on the RF170C connection module

Table 7-21 Status and error LEDs for RF170C

LEDs	Meaning*
SF	Group errors
ACT_1, ACT_2	The corresponding reader / (write/read device) is active in processing a user command. (MOBY I only)
ERR_1, ERR_2 *	A flashing pattern indicates the last error to occur.
PRE_1, PRE_2 **	Indicates the presence of a transponder/MDS.
RxD_1, RxD_2	Indicates live communication with the reader / write/read device. May also indicate malfunctions on the reader / write/read device.
<p>* The meaning of the individual flashing pattern is described in the relevant FB and FC documentation. That documentation also includes the associated error descriptions.</p> <p>** In the case of multitag operation, this LED uses a flashing interval to indicate the number of data carriers currently within the range of the reader / write/read device.</p>	