

System integration

The communication modules (interface modules) are links between the RFID components (reader and transponder) and the higher-level controllers (e.g. SIMATIC S7), or PCs or computers.

8.2 Introduction

RF310R, RF340R, RF350R and RF380R readers are connected to the controller via the following interface/communication modules:

- ASM 452
- ASM 456
- ASM 473
- ASM 475
- RF170C
- RF180C
- RF182C
- 8xIQ-Sense

Function blocks, interface modules/communication modules and readers

Function blocks are used for integration into the SIMATIC. Using these, the input parameters are transferred to the reader using the "init_run"(RESET) command.

You can find more detailed information on the software parameterization in Product Information "FB 45 and FC 45 input parameters for RF300 and ISO transponders" (<http://support.automation.siemens.com/WW/view/en/33315697>) or the Function Manual FB 45 (<http://support.automation.siemens.com/WW/view/en/21738808>) from edition A3 onwards.

Interface modules/communication modules and function blocks

The following table shows the most important features of the interface modules/communication modules, as well as the compatible function blocks.

Table 8- 1 Overview of interface modules/communication modules

ASM/ communication module	Interfaces to the application (PLC)	Interfaces to the reader	Function blocks	Reader connections	Dimensions (W x H x D) in mm	Temperature range	Degree of protection
ASM 452	PROFIBUS DP-V1	2 x 8-pin socket, M12	FC 45	1	134 x 110 x 55	0 °C to +55 °C	IP67
ASM 456	PROFIBUS DP-V1	2 x 8-pin socket, M12	FB 45 FC 55 FC 56	2 (parallel) *	60 x 210 x 54 or 79	0 °C to +55 °C	IP67
ASM 473	PROFIBUS DP-V1	2 x 8-pin socket, M12	FC 45 FB 45 FC 55	1	87 x 110 x 55	0 °C to +55 °C	IP67
ASM 475	S7-300 (central), ET200M (PROFIBUS)	Via screw terminals in front connector	FC 45 FB 45 FC 55	2	40 x 125 x 120	0 °C to +60 °C	IP20
SIMATIC RF170C	PROFIBUS DP-V1 PROFINET IO	2 x 8-pin socket, M12	FB 45 FC 55	2 (parallel) *	90 x 130 x 60	-25 °C to +55° C	IP67
SIMATIC RF180C	PROFINET IO	2 x 8-pin socket, M12	FB 45	2 (parallel) *	60 x 210 54	0 °C to +60° C	IP67
SIMATIC RF182C	PROFINET IO	2 x 8-pin socket, M12	—	2 (parallel) *	60 x 210 x 30	0 to +60 °C	IP67
8xIQ-Sense	8xIQ-Sense	Via screw terminals in front connector	FC 35	2 (parallel) *	40 x 125 x 120	0 °C to +60 °C	IP20
<p>*) If 2 readers are used on one ASM, the following restrictions apply:</p> <ul style="list-style-type: none"> • The maximum operating temperature is 35 °C • The input voltage is 24 V ±10% <p>Current consumption ≤ 425 mA per reader</p>							

8.3 ASM 452

8.3.1 Features

Area of application

The ASM 452 interface module is a MOBY module for operating MOBY and RF300 components with RS422 over PROFIBUS DP-V1 on

- Any computers and PCs
- Any PLCs

When operating the interface module on a SIMATIC S7, function blocks are made available to the user.



Figure 8-1 Interface module ASM 452

The ASM 452 is the result of consistent development of the familiar ASM 450/451 interface modules. Optimal data throughput can be achieved even in large-scale PROFIBUS configurations thanks to the use of acyclic data traffic on PROFIBUS DP V1. The minimum cyclic data load of the ASM 452 on the PROFIBUS provides the user with the guarantee that other PROFIBUS nodes (e.g. DI/DO) can still be processed at great speed.

The ASM 452 is an interface module for communication between PROFIBUS and the RF310R with RS422 interface. Through the ASM 452, the data on the RF300 transponder can be physically addressed ("Normal" addressing). In SIMATIC S7, FC 45 is available for this purpose.

8.3.2 Ordering data

Table 8-2 Ordering data for ASM 452 and accessories

Product description	Order No.
ASM 452 interface module for PROFIBUS DP-V1, 1x RF3xxR with RS422 interface, without connector for 24 V DC and PROFIBUS	6GT2002-0EB20
Accessories:	
Connector for PROFIBUS DP and 24 V supply	6ES7194-1AA00-0XA0
Connecting cable RF3xxR ↔ ASM 452	

Product description	Order No.
Plug-in cable, pre-assembled, length: 2 m (standard length)	6GT2891-1CH20
Plug-in cable, pre-assembled, length: 5 m	6GT2891-1CH50
Opt. Cable connector without read/write device cable (for cable lengths > 20 m) ASM 452 ↔ reader	6GT2090-0BC00
M12 blanking cap for unused RF310R connection (1 pack = 10 pieces)	3RX9802-0AA00
CD "RFID Systems Software & Documentation" with FC 45, GSD file	6GT2080-2AA10
Replacement part: Connector plate; T functionality for PROFIBUS connection	6ES7194-1FC00-0XA0
FC 45 Reference Manual German English French	Available in electronic form on the CD "RFID Systems Software & Documentation"

The ASM 456 plug-in cables 6GT2891-0Fxxx can be used as extension cables.

8.3.3 Pin assignment and display elements

Pin assignments

The figure below illustrates the pin assignments of ASM 452.

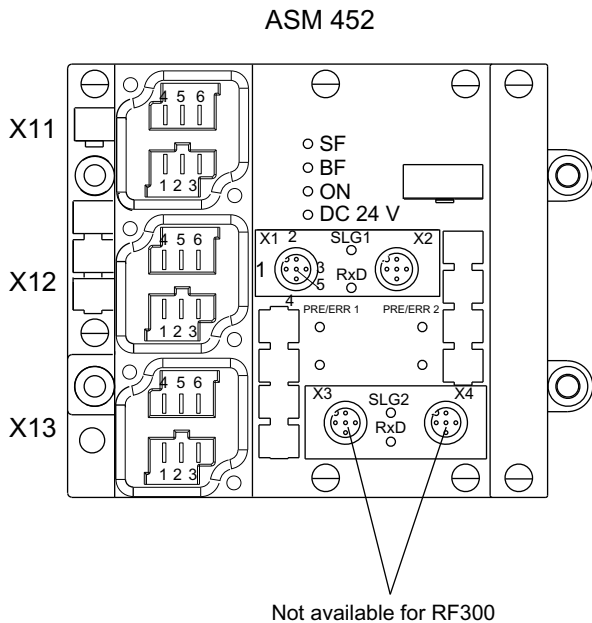

LEDs for PROFIBUS DP

SF: System Fault
BF: Bus Fault

ON: Lights up when there is ASM (is generated by the 24 V supply voltage).
24 V DC: Lights up when the 24 V supply voltage is connected to the ASM.

LEDs for RF300 and ASM 452

RxD: Reader active with
PRE/ERR 1 Transponder present or error display
(PRE/ERR 2) for reader
(The "transponder present" display always takes priority. The error is only indicated when a transponder is not present.)

Transponder present: The LED is permanently ON. If more than one transponder is in the field, the number of transponders is indicated by short interruptions. A fault is not output.

Error display:

The LED is permanently OFF. The last error number is indicated by brief light pulses.

Reader 1: Reader 1 is selected
(Reader 2) (Reader 2 is selected.)

Only reader 1 can be selected.

Socket	Pin assignment
X11 and X12 (PROFIBUS DP)	1 Signal
	2 PE
	3* PE
	4 Signal
	5* L+
	6* M
X13 (Supply voltage)	1 PE
	2 L+
	3 M
	4 PE
	5 L+
	6 M

* Not connected

Socket	Pin assignment (reader)
X1 (X3) (green)	1 +RxD
	2 +TxD
	3 -TxD
	4 -RxD
	5 PE
X2 (X4)	X2 X4
	1 +24 V +24 V
	2 DA1 DE 1
	3 0 V 0 V
	4 DA0 DE 0
5 PE PE	

Figure 8-2 Pin assignment and LEDs of ASM 452

8.3.4 Configuration

Configuration

Hardware description

The ASM 452 has the same housing as the distributed I/O system ET 200X. General information on ASM 452 (e.g.: assembly, operation and wiring; general technical data) is available in the ET200X manual (Order No. 6ES7 198-8FA00-8AA0). Descriptions of accessories and network components can also be found in this manual.

Configuration

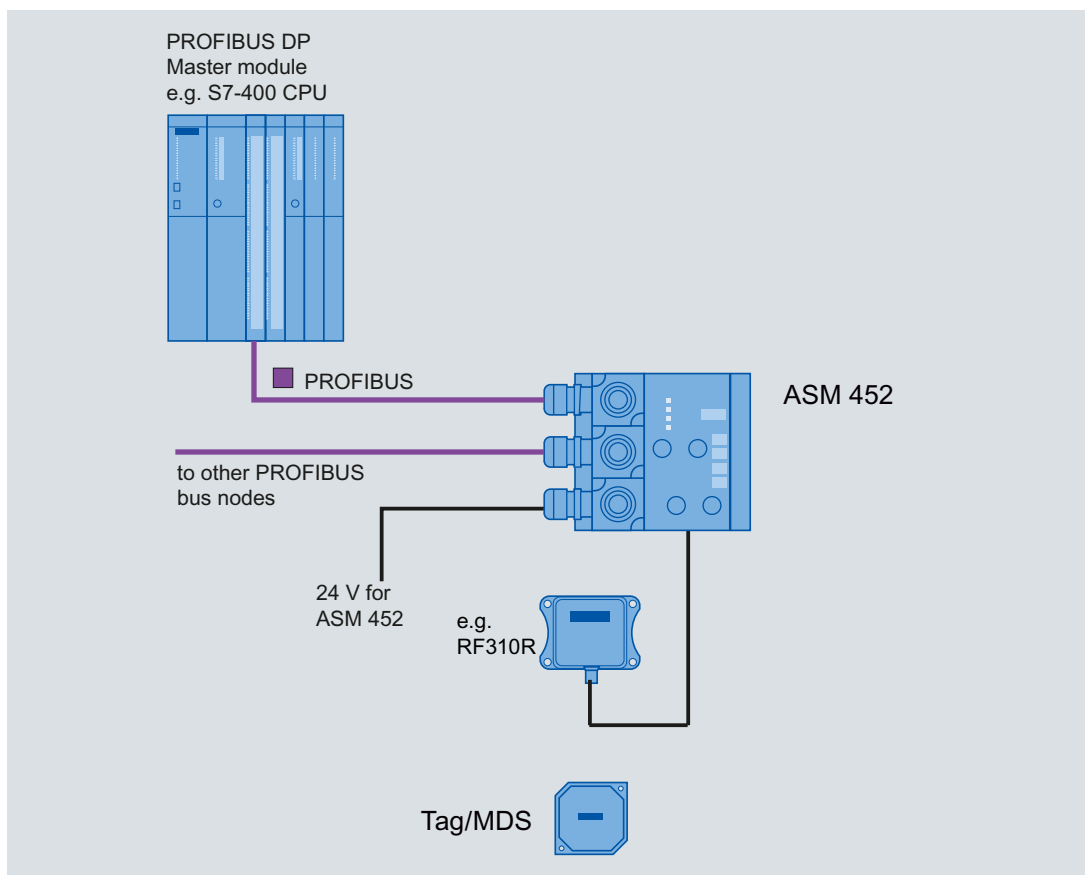

Figure 8-3 Configuration of ASM 452

PROFIBUS configuration

The ASM 452 is integrated into the hardware configuration by means of a GSD file. The ASM can then be configured using the HW Config of SIMATIC Manager or another PROFIBUS tool. A GSD file is provided for ASM 452 on the CD "RFID Systems Software & Documentation".

Operating mode of the ASM 452

The approved operating modes of ASM 452 are described in the GSD file. It is set using the hardware configuration tool (e.g. STEP 7 HW Config).

Reader connection system

A reader always occupies two M12 connector sockets on the ASM 452.

A pre-assembled cable therefore ensures easy connection of the reader (see figure below).

The connecting cable is available in lengths of 2 m (standard) and 5 m. Extensions are possible up to 1000 m using connecting cables 6GT2891-...

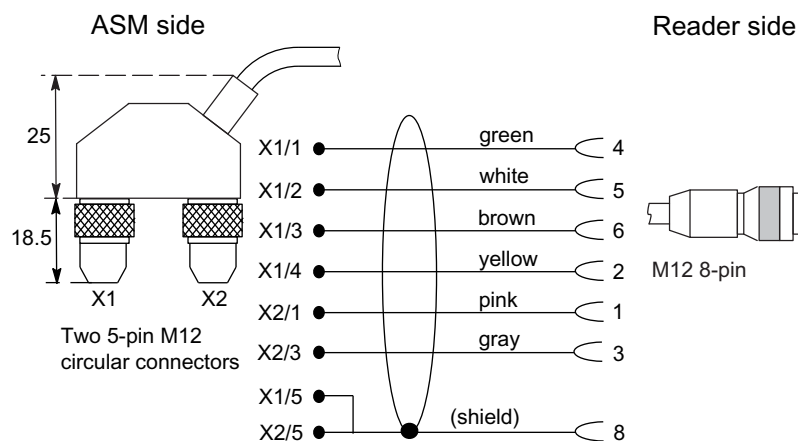

Figure 8-4 Connecting cable (2 m) ASM 452/473 ↔ RF3xxR reader with RS422 (6GT2891-1CH20)

Cable installation

Signal	M12 (reader side)	Cable	X1 / Data	X2
24 V DC	1	Pink	-	1
TX -	2	Yellow	4	-
GND	3	Gray	-	3
TX +	4	Green	1	-
RX +	5	white	2	-
RX -	6	brown	3	-
-			-	-
Shield	8 + terminal piece	Shield	5	5

Cable assignment ASM 452/473 ↔ RF3xxR reader with RS422 (6GT2891-1CH20)

A reader cable connector with screw-type terminals is provided for users who want to individually pre-assemble their own cables (see figure below). Cables and reader cable connectors can be ordered from the MOBY catalog.

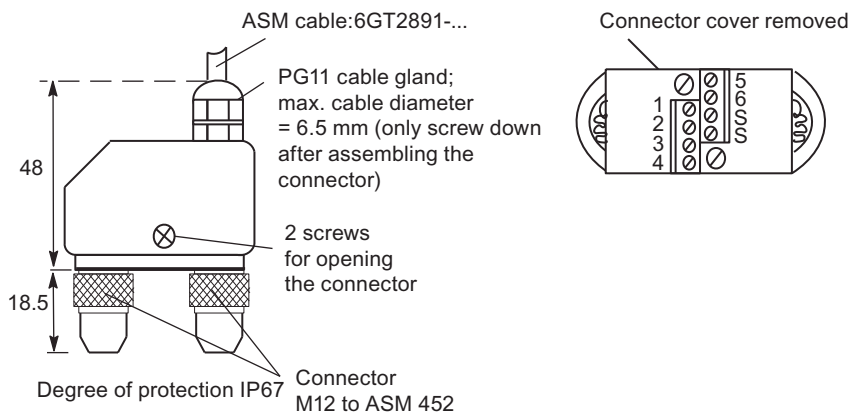

Figure 8-5 Cable connector ASM 452/473 ↔ RF3xx reader with RS422 (6GT2090-0BC00)

Pin assignment for ASM 452/473 cable connector

Connector pin	Connection to pin of the reader	Wire color
1	4	Note data sheet provided by the manufacturer
2	5	
3	6	
4	2	
5	3	
6	1	
S	-	
	8 + terminal piece	

Pin 7 must not be connected.

PROFIBUS cable with 24 V supply

The ASM 452 can also be operated with the "green" PROFIBUS cable. It is important to ensure that a 24 V cable is connected from X12 to X13. The 24 V cable can be connected to pins 5 and 6 in plug X12.

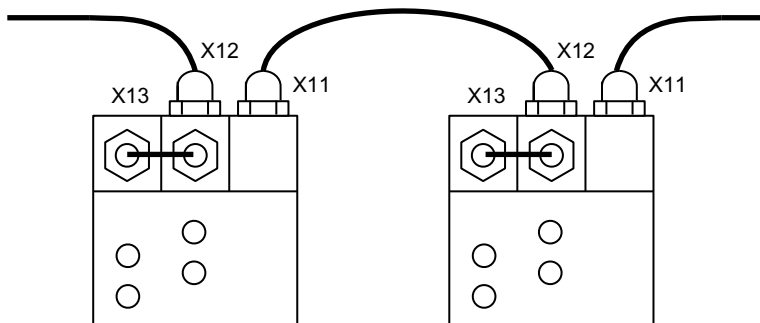

Figure 8-6 PROFIBUS cable with 24 V supply

PROFIBUS address and terminating resistor

You must remove the connector plate from the ASM before you set the PROFIBUS address or connect the terminating resistor. The connector plate covers the DIL switch. The position of the DIL switch in ASM is shown in the figure below with one setting example for each case.

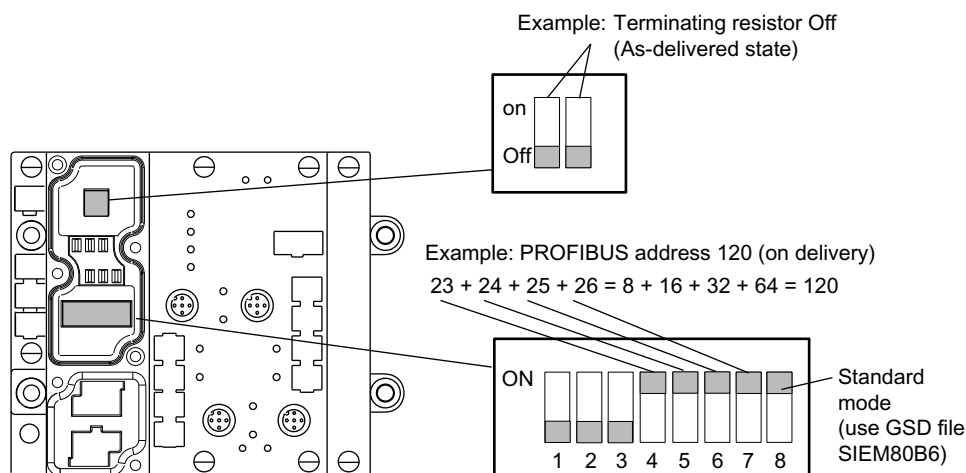

Figure 8-7 Setting the PROFIBUS address/connecting the terminating resistor

Note

- The PROFIBUS address in ASM 452 must always match the PROFIBUS address defined in the configuring software for this ASM.
- To ensure that the terminating resistor functions correctly, you must always switch **both** DIL switches of the terminating resistor to "on" or "off".

8.3.5 Technical data

Table 8-3 Technical data for ASM 452

Serial interface to the user	PROFIBUS DP-V1
Procedure after connection	EN 50170 Vol. 2 PROFIBUS PG 11 cable gland PROFIBUS and power supply connectors are not included in the scope of delivery
Transmission rate	9600 baud to 12 Mbaud (automatic detection)
Max. block length	2 words cyclic/240 bytes acyclic
Serial interface to the RF3xxR	
Connector	2 x M12 coupler plug
Max. cable length	2 m = Standard length, 5 m, 10 m, 20 m and 50 m, (up to 1000 m on request)
Readers that can be connected	1x RF3xxR with RS422 interface

Software functions	
Programming	Depending on the PROFIBUS DP master
Function blocks for SIMATIC S7	FC 45
Transponder addressing	Direct access via addresses
Commands	Initialize transponder, read data from transponder, write data to transponder
Multi-tag capability	No
S7 data structures via UDTs	Yes
Power supply	
Rated value	24 V DC
Permissible range	20 V to 30 V DC
Current consumption	Max. 180 mA; typ. 130 mA (without reader)
Digital inputs	none
Digital outputs	none
Ambient temperature	
Operation	0 °C to +55 °C
Storage and transport	-40 °C to +70 °C
Dimensions (W x H x D) in mm	134 x 110 x 55 (without bus connector)
Fixing	4 M5 screws; for mounting on any plate or wall
Weight, approx.	0,5 kg
Degree of protection	IP67
MTBF (at 40 °C)	30 • 10 ⁴ hours = 34 years

8.3.6 PROFIBUS Diagnosis

The following table lists possible error indications with their meanings and provides remedies.

Table 8- 4 LED indication for PROFIBUS diagnosis

"BF" LED	"SF"LED	Cause of error	Error correction
ON	*	<ul style="list-style-type: none"> • ASM 452 is in start-up mode. 	-
		<ul style="list-style-type: none"> • The connection to the DP master has failed. • ASM 452 not detecting a baud rate. 	<ul style="list-style-type: none"> • Check the PROFIBUS DP connection. • Check the DP master.
		<ul style="list-style-type: none"> • Bus interrupt • DP Master not functioning 	<ul style="list-style-type: none"> • Check all cables on your PROFIBUS DP network. • Check whether the connector plugs for PROFIBUS DP are securely plugged into the ASM 452.

"BF" LED	"SF"LED	Cause of error	Error correction
flashes	on	<ul style="list-style-type: none"> The configuration data sent to the ASM 452 by the DP master do not match the configuration of the ASM 452. 	<ul style="list-style-type: none"> Check the configuration of the ASM 452 (input/output, PROFIBUS address). Correct GSD file being used? <ul style="list-style-type: none"> SIEM80B6.GSD for ASM 452
Flashes	Off	<ul style="list-style-type: none"> ASM 452 has detected the baud rate, but is not being addressed by the DP Master. ASM 452 has not been configured. 	<ul style="list-style-type: none"> Check the PROFIBUS address set on the ASM 452 or in the configuration software. Check the configuration of the ASM 452 (station type).
on	Flashes	<ul style="list-style-type: none"> There is a hardware defect in the ASM 452. 	<ul style="list-style-type: none"> Replace the ASM 452.

8.3.7 Dimension drawing

The following figure shows the dimensional drawing of an ASM 452 with bus connectors. You must add the length of the PG cable gland and the radius of the cable used to the measured overall width and depth.

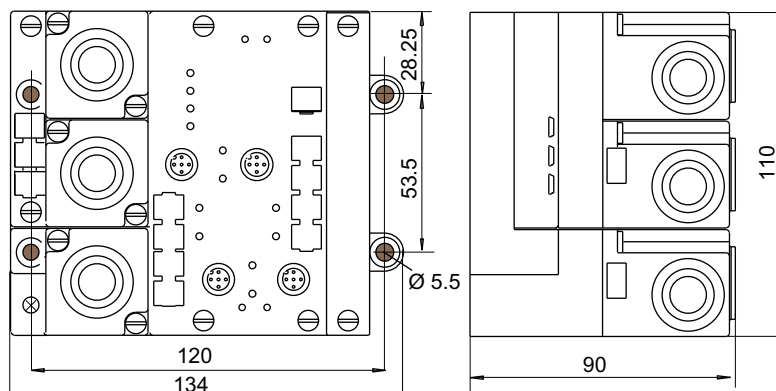

Figure 8-8 Dimensional drawing of ASM 452

Example of stripped lengths

The following diagram shows an example of stripped lengths. The lengths apply to all cables which can be connected to the connector plugs. You must twist any shield braid present, plug into a core end sleeve and cut off any excess.

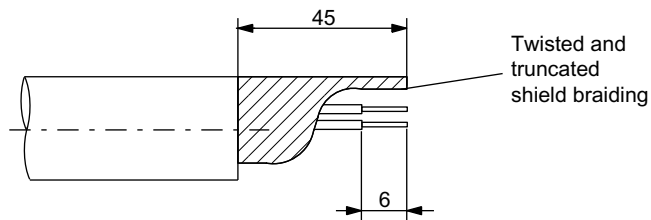

Figure 8-9 Length of stripped insulation for PROFIBUS cables

8.4 ASM 456

Configured with ASM 456

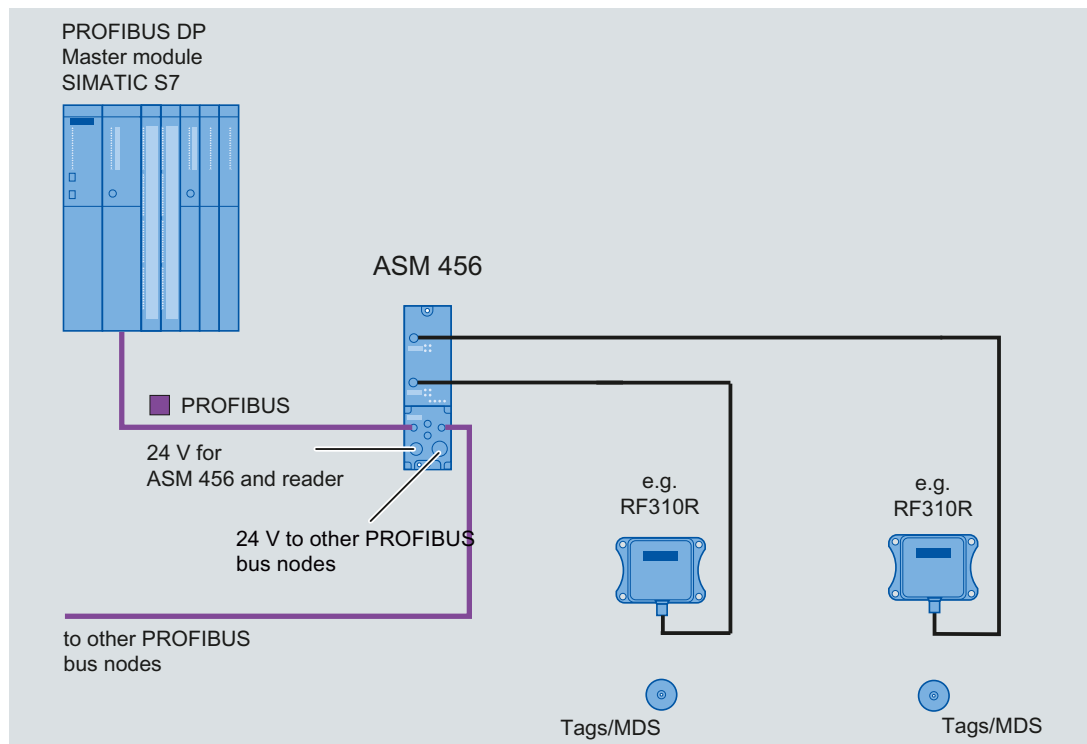

Figure 8-10 Configuration of ASM 456

For more detailed information, please refer to ASM 456 Operating Instructions (<http://support.automation.siemens.com/WW/view/en/32629442>).

8.5 ASM 473

8.5.1 Features

Field of application

The ASM 473 interface module is an RF300 module for SIMATIC S7. It can be plugged into the ET 200X distributed I/O station and DESINA. ET 200X is operated by the user over PROFIBUS DP V1. An S7-300 or S7-400 with integrated PROFIBUS connection can be used as the controller.

ASM 473 supplements the SIMATIC S7 interface module ASM 475. The IP67 degree of protection means that it can be installed and operated in the process without the need for an additional protective housing.

To operate the ASM 473, an ET 200X basic module BM 141/142 with the order number 6ES7141-1BF11-0XB0 or 6ES7142-1BD21-0XB0 or a BM 143 is required.

The transponder data are accessed by means of physical addressing of the transponder.

For operation in a SIMATIC S7, the function FC 45 is available. The hardware of the ASM 473 is configured with an object manager (OM) that is integrated in the SIMATIC Manager.



Figure 8-11 Interface module ASM 473

Other features:

- Up to 7 ASM 473 interface modules can be operated simultaneously in an ET 200X station.
- Any other I/O modules from the ET 200X spectrum can be operated with the ASM 473.

8.5.2 Ordering data

Table 8- 5 Ordering data for ASM 473 and accessories

Product description	Order No.
Interface module ASM 473 1x RF3xxR reader with RS422 interface	6GT2002-0HA10
Accessories:	

Product description	Order No.
Connecting cable ASM 473 ↔ Reader RF3xxR	
Plug-in cable, pre-assembled, length 2 m (standard length)	6GT2891-1CH20
Plug-in cable, pre-assembled, length 5 m	6GT2891-1CH50
Opt. Cable connector without reader cable (for cable lengths > 20 m) ASM 473 ↔ Reader	6GT2090-0BC00
CD "RFID Systems Software & Documentation" with FC 45, GSD file	6GT2080-2AA10
FC 45 Reference Manual German English French	Available in electronic form on the CD "RFID Systems Software & Documentation"

8.5.3 Pin assignment and display elements

Pin assignments

The figure below illustrates the pin assignment for the read/write device and the display elements.

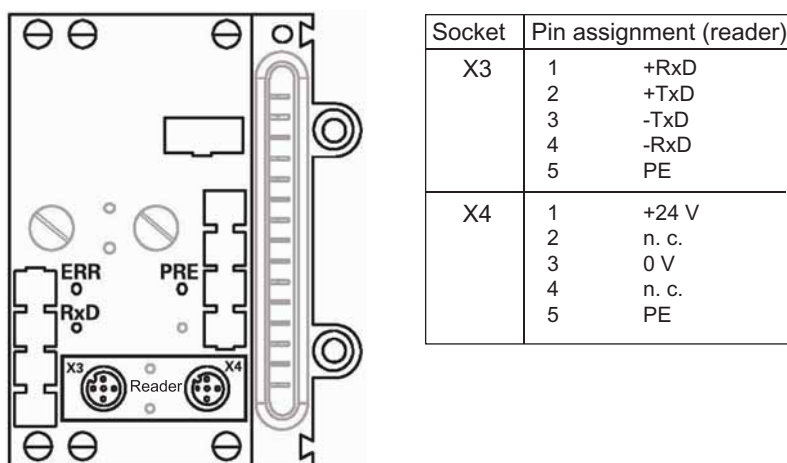

LEDs for PROFIBUS DP

General indicators (SF, BF, ON, 24VDC) are located on the basic module of the ET 200X.

LEDs for MOBY

RxD: Reader active with command
 PRE: Indicates the presence of a transponder
 ERR: Error indicated by flashing sequence

The following ASM states are also indicated with the LEDs "PRE" and "ERR":

PRE	ERR	Description, Causes, Remedy
OFF/ON	ON (perm.)	Hardware is defective (RAM, flash,...)
ON	OFF	Charger is defective (can only be repaired in the factory).
2 Hz	OFF	Firmware loading is active or no firmware detected → Load firmware → ASM must not be switched off until loaded
2 Hz	2 Hz	Firmware loading terminated with errors → Restart required → Load firmware again → Check update files
5 Hz	5 Hz	Operating system error → Switch ASM or ET 200X base station OFF/ON
OFF	1 x flash every 2 s	ASM has booted and is waiting for a RESET (init_run) from the user

Figure 8-12 Interfaces and indicators of the ASM 473 for RF300

8.5.4 Configuration

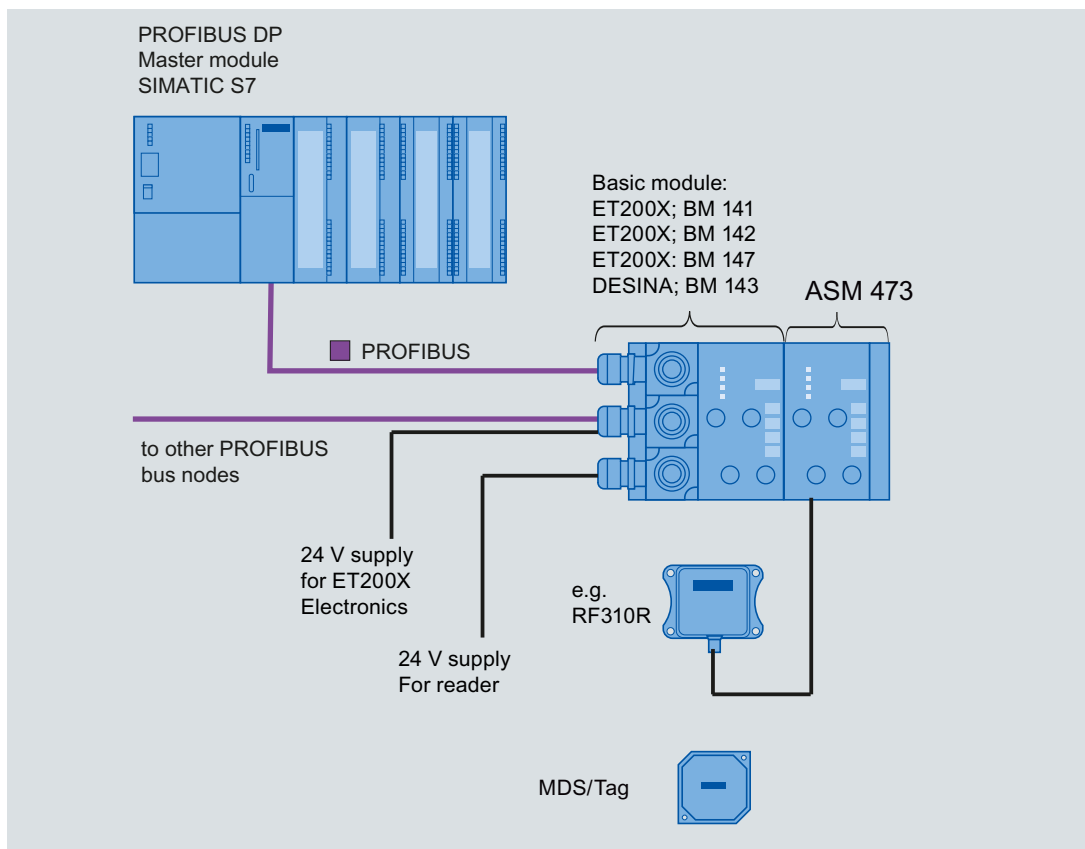

Figure 8-13 Configuration of ASM 473

Note

It differs from ASM 452 in that for ET 200X the 24 V supply must be connected to the PROFIBUS connector **and** on the load voltage connector (see the ET 200X manual).

Basic module - Requirements for operation of ASM 473

The following table indicates the status of the ET 200X basic module of 10/2002. The functionality of new basic modules is stored in HW Config of the SIMATIC Manager.

Table 8-6 Requirements for operation of ASM 473

Order number of the ET 200X basic module	For operation with ASM 473 (6GT2002-0HA00)*	For operation with ASM 473 PARAM (6GT2002-0HA10)
6ES7141-1BF00-0XB0	No	No
6ES7141-1BF00-0AB0	Yes	Yes
6ES7141-1BF01-0XB0	No	No
6ES7141-1BF10-0XB0	No	No

Order number of the ET 200X basic module	For operation with ASM 473 (6GT2002-0HA00)*	For operation with ASM 473 PARAM (6GT2002-0HA10)
6ES7141-1BF11-0XB0	Yes	Yes
6ES7141-1BF40-0AB0	Yes	Yes
6ES7142-1BD10-0XB0	No	No
6ES7142-1BD11-0XB0	No	No
6ES7142-1BD20-0XB0	No	No
6ES7142-1BD21-0XB0	Yes	Yes
6ES7142-1BD22-0XB0	No	Yes**
6ES7143-1BF00-0AB0	Yes	Yes
6ES7143-1BF00-0XB0	Yes	Yes
6ES7147-1AA00-0XB0	No	No
6ES7147-1AA01-0XB0	No	Yes
* Discontinued		
** Notes on operation: In HW Config, please parameterize the module 6ES7142-1BD21-0XB0.		

Example for a maximum configuration of ASM 473 on an ET 200X

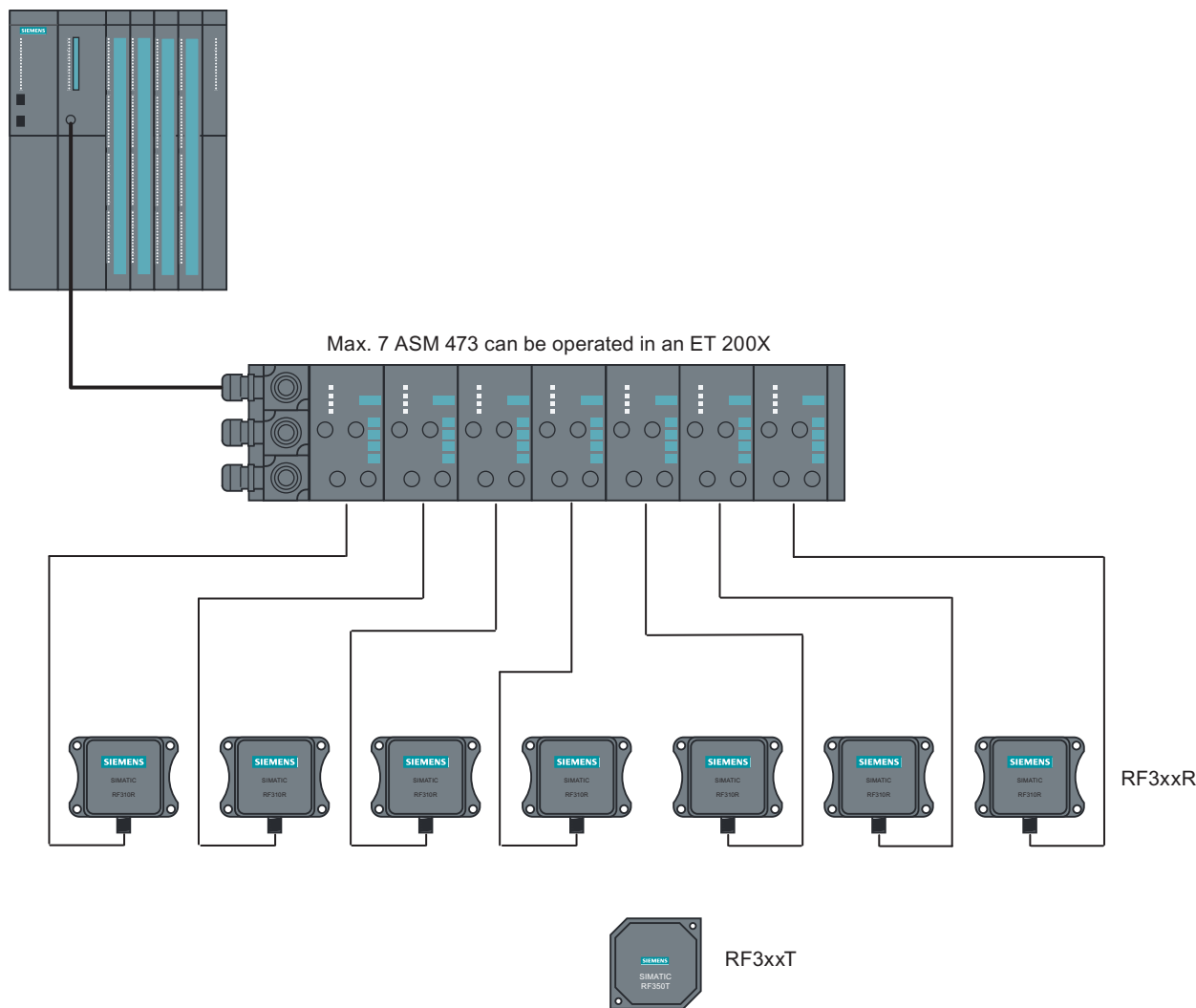

Figure 8-14 Example for a maximum configuration of ASM 473 on an ET 200X

Depending on the PROFIBUS master, up to 123 ET 200X modules can be run on one PROFIBUS branch.

Hardware configuration

The ASM 473 is integrated in the hardware configuration of the SIMATIC Manager by calling Setup.exe in the directory daten\S7_OM on the "RFID Systems Software & Documentation" CD. Currently, the ASM 473 cannot be integrated in masters of other manufacturers.

Reader connection system

A reader always occupies the two M12 connection sockets X3 and X4 on the ASM 473. A prefabricated cable makes it easy to connect the reader. The standard version of the connecting cable is 2 m in length. Other cable lengths are available on request. For customers who want to assemble their own cables, an ASM cable connector with screw-

type terminals is available. Cables and ASM cable connectors can be ordered from the MOBY catalog.

8.5.5 Technical data

Table 8- 7 Technical specifications for ASM 473

Interface for ET 200X	SIMATIC S7 I/O bus cyclic/acyclic services
Communication	2 words cyclic/238 bytes acyclic
Command buffer in ASM	142 x 238 bytes
Serial interface to the reader	
• Connector	2 x M12 coupler plug
• Max. cable length	2 m = standard length; other pre-assembled cables = 5 m, (up to 1000 m on request)
• Readers that can be connected	1 x RF3xxR reader with RS422
Software functions	
Programming	Depending on the PROFIBUS DP master
Function blocks for SIMATIC S7	FC 45, FB 45, FC 55
MDS addressing	Direct access via addresses
Commands	Initialize transponder, read data from transponder, write data to transponder, etc.
PROFIBUS Diagnosis	Yes; in accordance with ET 200X basic station
S7 diagnostics	Yes, can be called up via S7 OM
Reloadable firmware	Yes, via S7 OEM
Power supply ¹	
• Rated value	24 V DC
• Permissible range	20.4 V to 28.8 V DC
Current consumption	Typ. 75 mA; max. 500 mA (or see Technical specifications of the connected reader)
Power dissipation of the module	Typically 1.6 W
Digital outputs/inputs	Via expansion modules from the ET 200X spectrum
Ambient temperature	
• Operation	0 °C to +55 °C
• Transport and storage	-40 °C to +70 °C
Dimensions (W x H x D) in mm	
• Single unit	87 x 110 x 55
• Width module	60 x 110 x 55

Fixing	2 M5 screws (customer side) 2 M3 screws (product side)
Degree of protection	IP67
Weight, approx.	0.275 kg

For installation instructions and general technical data, see the ET 200X manual.

8.5.6 Dimensional drawings

Dimension drawing for mounting holes

The figure below shows the dimensions for the position of the holes for the fixing screws for a basic module and an ASM 473 expansion module.

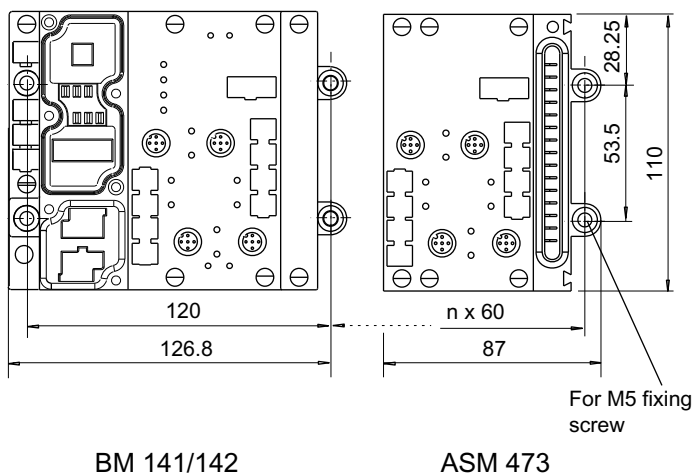

n = Number of expansion modules

Figure 8-15 Dimensions for fixing holes for basic modules and expansion modules

Example of stripped lengths

The following diagram shows an example of stripped lengths. The lengths apply to all cables which can be connected to the connector plugs. You must twist any shield braid present, plug into a core end sleeve and cut off any excess.

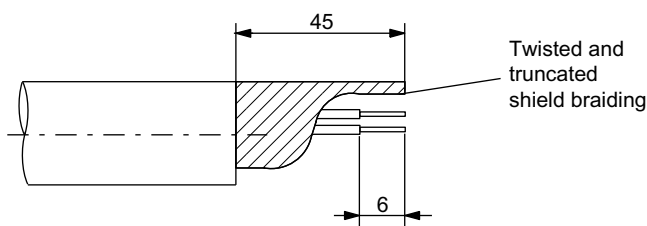

Figure 8-16 Length of stripped insulation for PROFIBUS cables

8.6 ASM 475

8.6.1 Features

Area of application

The ASM 475 interface module acting as the link between all RF300 systems and SIMATIC S7-300 performs the functions of a communication module. It can be operated centrally in the S7-300 or decentrally in an ET200M.

As many as eight ASM 475 interface modules can be plugged into one SIMATIC S7-300 rack and operated. In a configuration with several racks (max. four), the ASM 475 can be plugged into and operated on any rack. This means that as many as 32 ASMs can be operated in the maximum configuration of a SIMATIC S7-300. The ASM can also be operated in the ET 200M distributed I/O on PROFIBUS. Operation in an S7-400 environment is therefore problem-free. Up to 8 ASMs can be operated on each ET200M.

Error messages and operating states are indicated by LEDs.

A configuration that is resistant to interference is possible due to electrical isolation between the read/write device and the SIMATIC S7-300 bus.



Figure 8-17 Interface module ASM 475

The ASM 475 with the order number 6GT2002-0GA10 is a parameterizable module. The basic functions of the module are then already specified when the module is configured in HW Config (e.g. standard addressing).

The data in the MDS is accessed direct by means of physical addresses using the ASM 475. Operation in a SIMATIC S7 is controlled by the function FC 45.

ASM 475 and FC 45 form a unit that is used for reading the data of the MDS easily and at optimal speed.

8.6.2 Ordering data

Table 8- 8 Ordering data for ASM 475 and accessories

Product description	Order No.
ASM 475 interface module for SIMATIC S7 2 x RF3xxR reader with RS422 can be connected in parallel, without front connector	6GT2002-0GA10
Accessories:	
Front connector (1 x per ASM)	6ES7392-1AJ00-0AA0
Connecting cable ASM 475 ↔ RF3xxR	
Plug-in cable, pre-assembled, length: 2 m (standard length)	6GT2891-0EH20
Plug-in cable, pre-assembled, length: 5 m	6GT2891-0EH50
Terminal element (1 x per reader cable)	6ES7390-5BA00-0AA0
Shield connecting element	6ES7390-5AA00-0AA0
CD "RFID Systems Software & Documentation" with FC 45, S7 object manager	6GT2080-2AA10
FC 45 Reference Manual German English French	Available in electronic form on the CD "RFID Systems Software & Documentation"

The ASM 456 plug-in cables 6GT2891-0Fxxx can be used as extension cables.

8.6.3 Indicators

Bezel and indicator elements

The figure below illustrates the bezel of the ASM 475 and the inside of the front door complete with the associated connection diagram. The read/write devices must be connected to the ASM in accordance with the connection diagram.

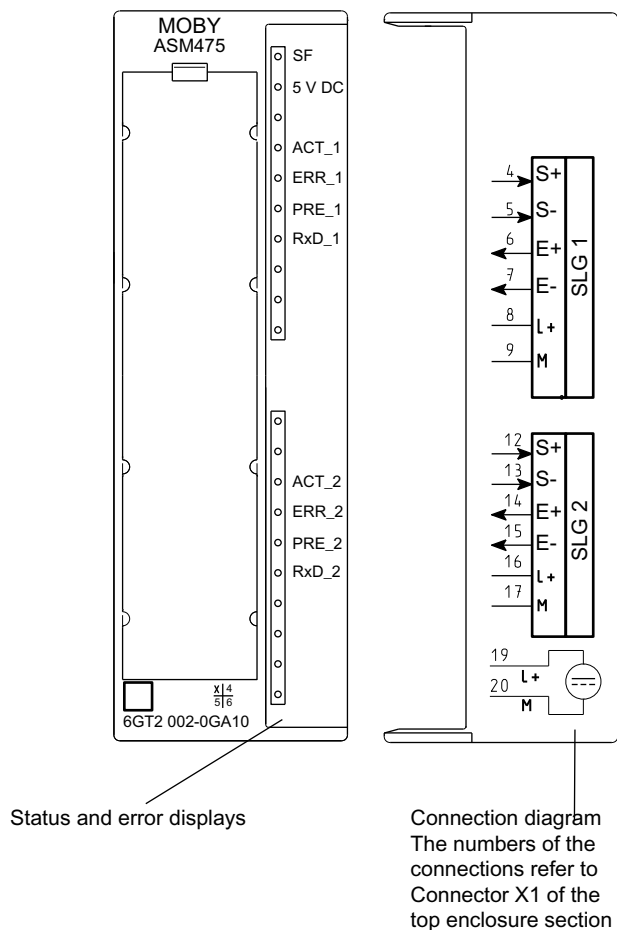

Figure 8-18 Bezel and inside of the front door of the ASM 475

Display elements on the ASM

Table 8- 9 Function of the LEDs on the ASM 475

Light emitting diode	Meaning
SF	System fault (hardware error on ASM)
DC 5V	24 V are connected to ASM and the 5 V voltage on ASM is OK.
ACT_1, ACT_2	The corresponding reader is active in processing a user command.
ERR_1, ERR_2	A flashing pattern indicates the last error to occur. This display can be reset using the parameter Option 1.

Light emitting diode	Meaning
PRE_1, PRE_2	Indicates the presence of a transponder.
RxD_1, RxD_2	Indicates live communication with the reader. In the event of a fault on the reader, this display may also be lit.

On the ASM 475, further operating states are indicated with the LEDs PRE, ERR and SF:

Table 8- 10 Operating status display on ASM 475 via LEDs

SF	PRE_1	ERR_1	PRE_2	ERR_2	Meaning
ON	OFF/ON	ON (perm.)	OFF/ON	ON (perm.)	Hardware is defective (RAM, Flash, etc.)
ON	OFF	ON	OFF	OFF	Charger is defective (can only be repaired in the factory).
OFF	2 Hz	OFF	2 Hz	OFF	Firmware loading is active or no firmware detected <ul style="list-style-type: none"> • Firmware download • ASM must not be switched off
OFF	2 Hz	2 Hz	2 Hz	2 Hz	Firmware loading terminated with errors <ul style="list-style-type: none"> • Restart required • Load firmware again • Check update files
Any value	5 Hz	5 Hz	5 Hz	5 Hz	Operating system error <ul style="list-style-type: none"> • Switch ASM off/on
OFF	OFF	1 flash every 2 s	OFF	1 flash every 2 s	ASM has booted and is waiting for a RESET (init_run) from the user.

8.6.4 Configuration

Centralized configuration with SIMATIC S7-300

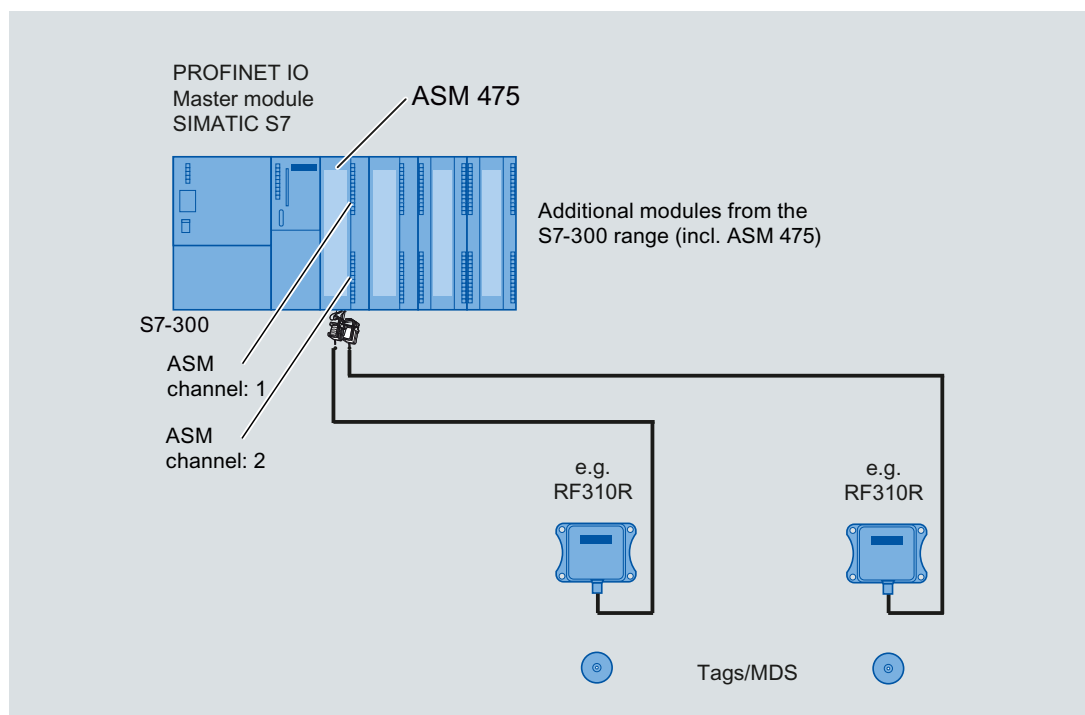

Figure 8-19 Configuration of ASM 475 central

Distributed configuration with ET200M

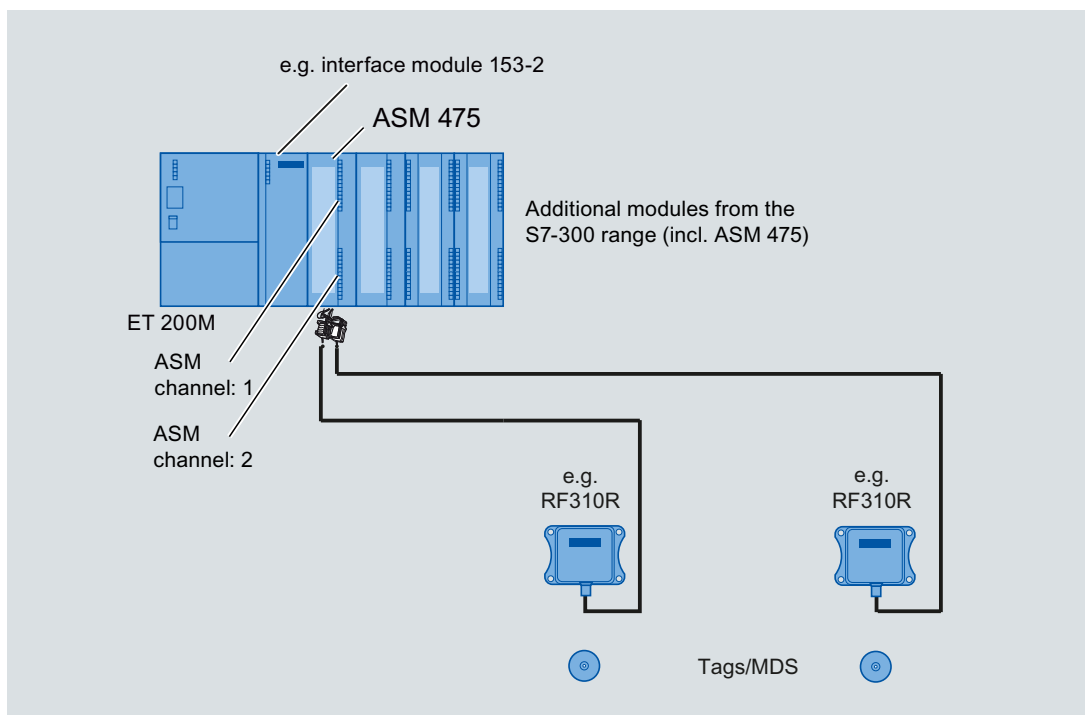
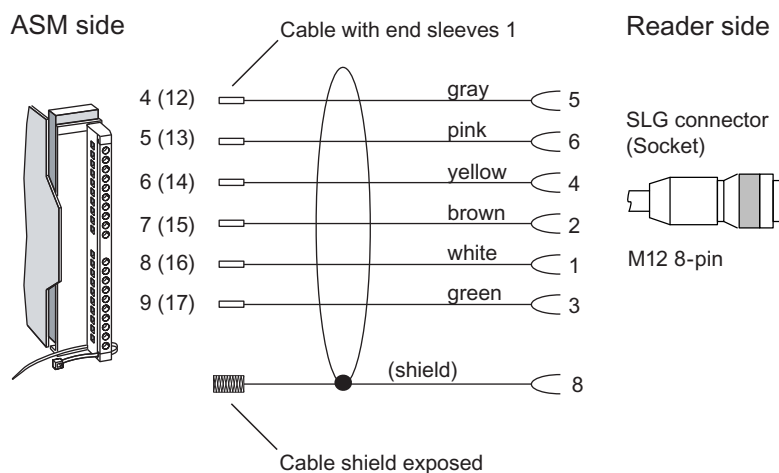

Figure 8-20 Configuration of ASM 475 distributed

Reader connection system

The connecting cable has a length of 2 m (standard) and 5 m. Extensions up to 1000 m are possible with the 6GT2891-0F plug-in cables.



¹ 6GT2891-0E... with straight SLG connector (standard)

Figure 8-21 Installation of connecting cable between ASM 475 and RF300 reader with RS 422

Cable installation

Signal	Pin on M12 connector	Cable	Labeling
24 V DC	1	white	1 Reader 2 8 -16
TX -	2	brown	1 Reader 2 7-15
GND	3	Green	1 Reader 2 9-17
TX +	4	Yellow	1 Reader 2 6-14
RX +	5	Gray	1 Reader 2 4-12
RX -	6	Pink	1 Reader 2 5-13
Shield	8 + terminal piece	-	

Cable assignment for connection of an RF300 reader to ASM 475

8.6.5 Technical data

Table 8- 11 Technical data for ASM 475

Serial interface for SIMATIC S7-300 or ET200M	I/O bus; cyclic and acyclic services
Communication	2 words cyclic/238 bytes acyclic
Command buffer in ASM 475	70 x 238 bytes per RF310R reader
Serial interface to the reader	
Connector	Via screw-type terminal on front connector The front connector is not included in the scope of supply.
Max. cable length	Pre-assembled cables = 2 m, 5 m, (up to 1000 m on request)
Readers that can be connected	2 x RF3xxR reader with RS422 parallel mode
Software functions	
Programming	Depending on the PROFIBUS DP master
Function blocks for SIMATIC S7	FC 45; FB 45; FC 55
Transponder addressing	Direct access via addresses
Commands	Initialize transponder, read data from transponder, write data to transponder

Multitag mode	No
S7 data structures via UDTs	Yes
Power supply	
Rated value	24 V DC
Permissible range	20.4 V to 28.8 V DC
Current consumption	
Without reader for U = 24 V DC, max.	350 mA
With reader connected, max.	500 mA, per connected reader
Power dissipation of the module, typ.	2 Watts
Current consumption from I/O bus, max.	80 mA
Electrical isolation between S7-300 and RF300	Yes
Fuse 24 V for the reader	Yes, electronic
Ambient temperature	
During operation	
Horizontal installation of SIMATIC	0 to +60 °C
Vertical installation of SIMATIC	0 to +40 °C
Transport and storage	-40 to +70 °C
Dimensions (W x H x D) in mm	40 x 125 x 120
Weight, approx.	0.2 kg

8.7 RF170C

Configured with RF170C

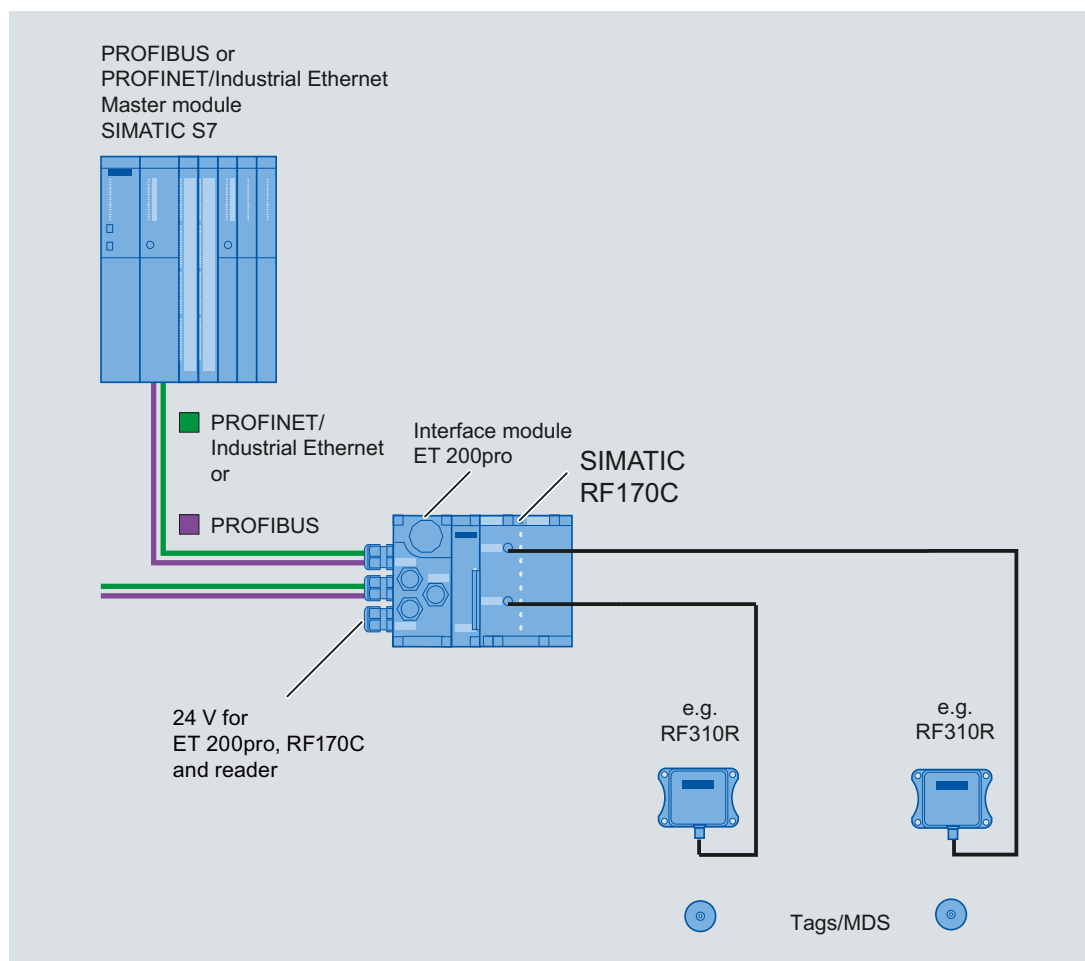

Figure 8-22 Configuration of RF170C

For more detailed information, refer to SIMATIC RF170C Operating Instructions (<http://support.automation.siemens.com/WW/view/en/32622825>).

8.8 RF180C

Configured with RF180C

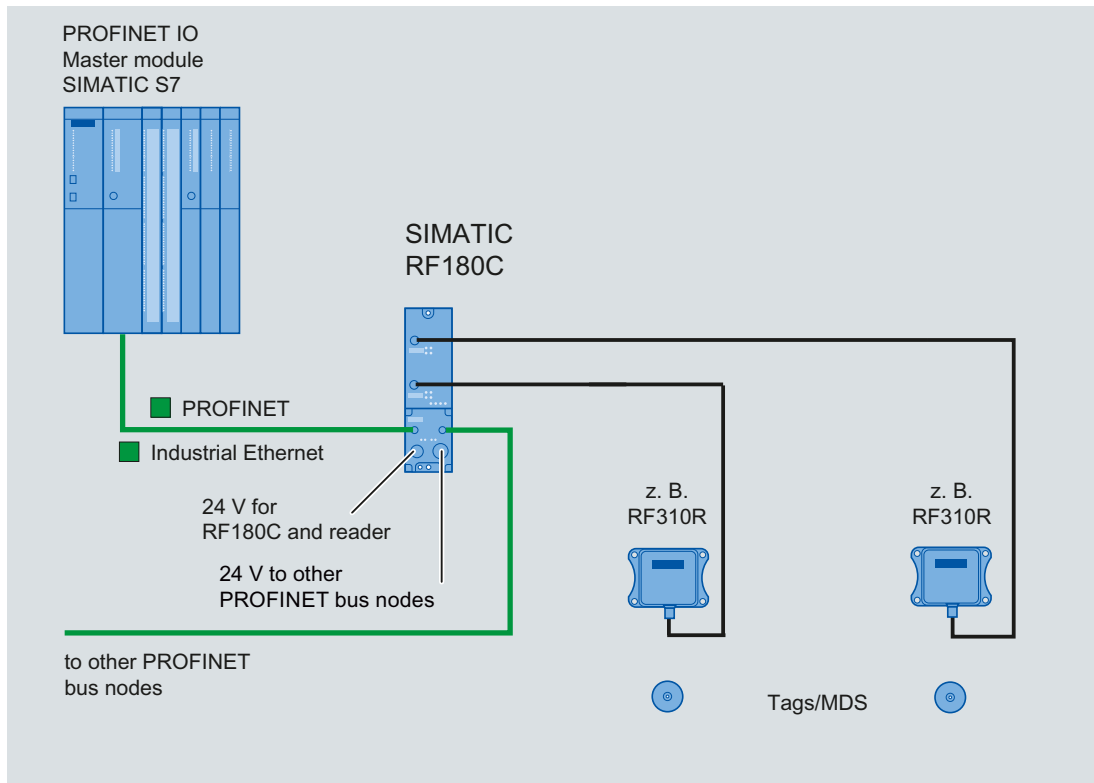

Figure 8-23 Configuration of RF180C

For more detailed information, refer to SIMATIC RF180C Operating Instructions (<http://support.automation.siemens.com/WW/view/en/30012157>).

8.9 RF182C

Configuration with RF182C

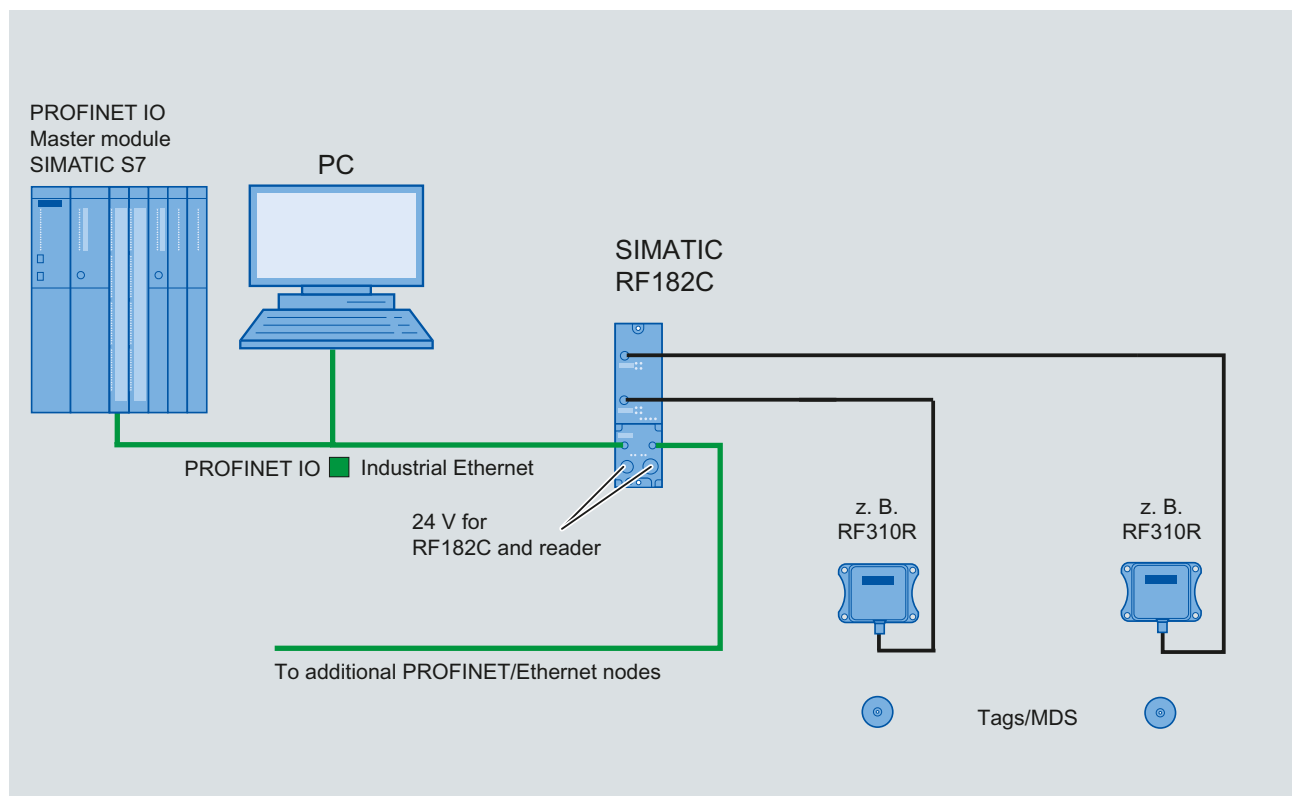

Figure 8-24 Configuration with RF182C

For more detailed information, refer to SIMATIC RF182C Operating Instructions (<http://support.automation.siemens.com/WW/view/en/38507897>).

8.10 8xIQ-Sense

8.10.1 Features

Field of application

The 8xIQ-Sense module is the link between the RF310R with 8xIQ-Sense interface and SIEMENS S7-300 and functions in the same manner as the communication module (interface module). It can be operated centrally in an S7-300 or decentrally in an ET200M.



Figure 8-25 8xIQ-Sense interface module

8.10.2 Ordering data

Table 8- 12 Ordering data for 8xIQ-Sense and accessories

	Order number
<ul style="list-style-type: none"> • IQ-Sense SM338 for S7-300 and ET200M for the connection of up to 8xIQ-Sense sensors • Optical sensors, ultrasonic sensors and RF identification systems can be connected. 	6ES7 3387XF000AB0

Table 8- 13 Ordering data for 8xIQ-Sense accessories

	Order number
M12 cable plug, 4-pole, with 5 m black PUR cable, 4 x 0.34 mm ²	3RX8000-0CB42-1AF0
M12 cable plug, 4-pole, with 10 m black PUR cable, 4 x 0.34 mm ²	3RX8000-0CB42-1AL0

8.10.3 Indicators

Status displays

The 8xIQ-Sense module has the following LEDs:
A green LED, which has no function for RFID devices, and a red SF LED (system fault LED), which indicates the diagnostic state of the module.

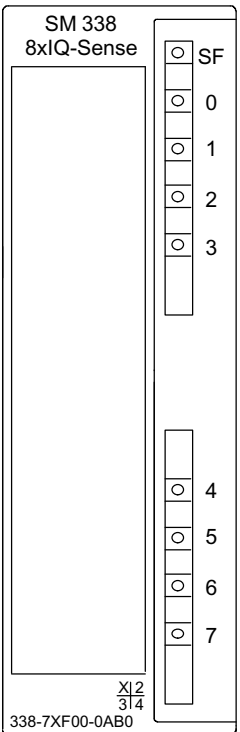
	LEDs	Labeling	LED status	Meaning
 <p>SM 338 8xIQ-Sense</p> <p>XI2 314</p> <p>338-7XF00-0AB0</p>	Green LED per channel	0...7	Has no function here	
	Red	SF	Illuminated Not illuminated	Module fault, sensor fault, active teach-in operation, external auxiliary voltage missing No fault or no active teach-in operation

8.10.4 Configuration

Centralized configuration with SIMATIC S7-300

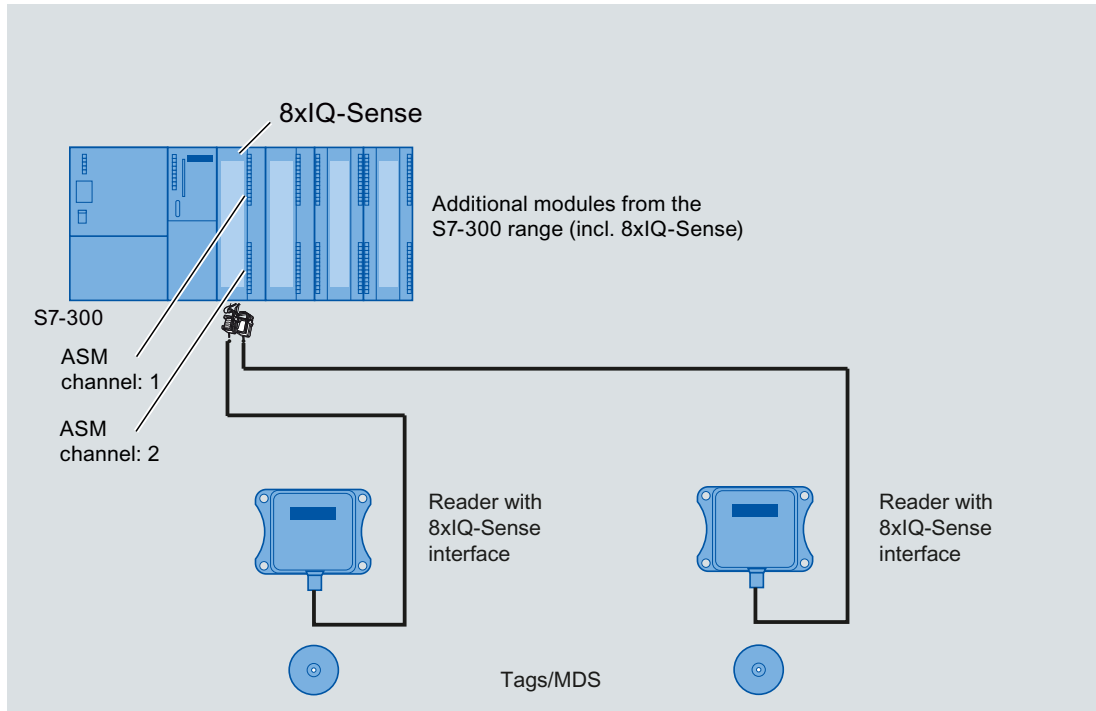

Figure 8-26 Configuration of 8xIQ-Sense central

Distributed configuration with ET 200M

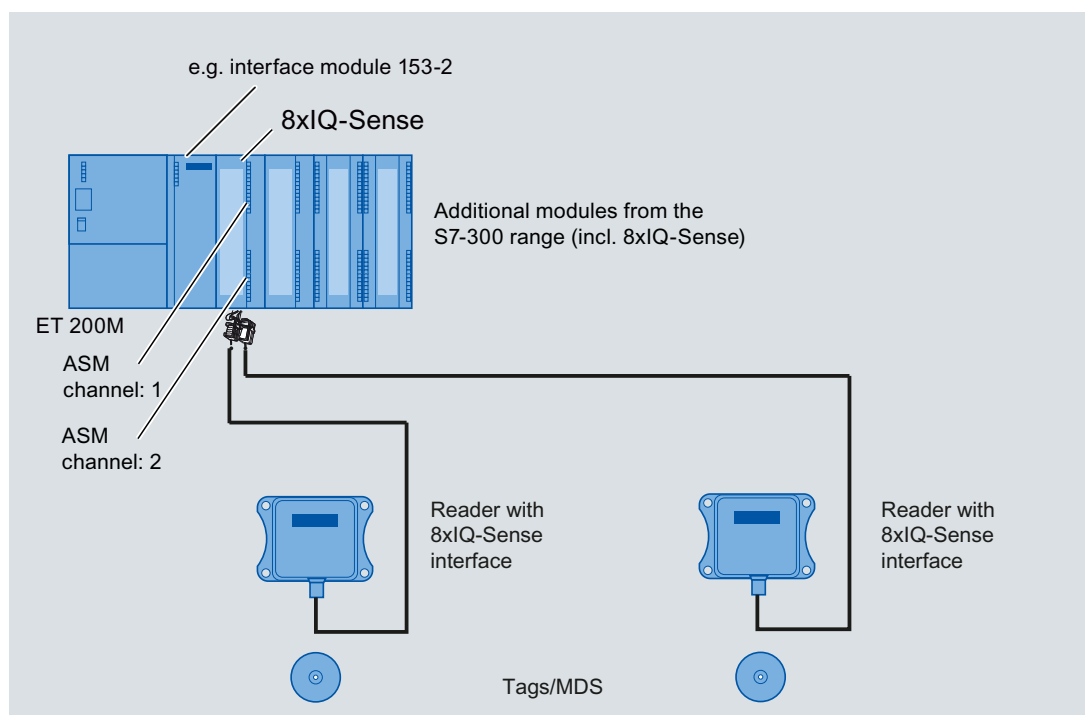

Figure 8-27 Configuration of 8xIQ-Sense distributed

Table 8- 14 Pin assignment of RF310R with IQ-Sense interface

Pin	Pin, device end, 4-pin M12	Assignment
	1	IQ-Sense
	2	Not used
	3	IQ-Sense
	4	Not used

Configuration of connecting cable from 8xIQ-Sense to RF310R

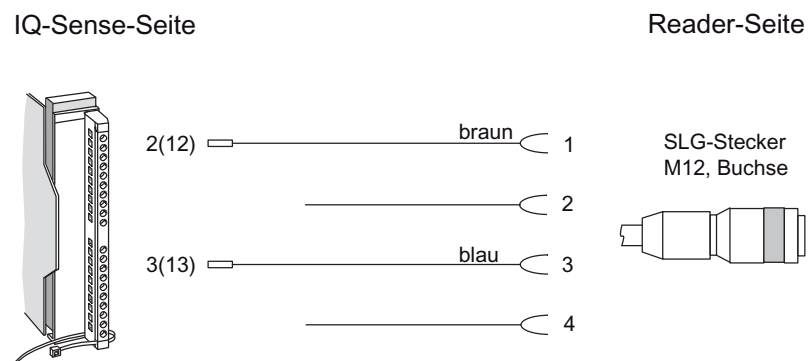

Figure 8-28 Cable and pin assignment of RF300 with IQ-Sense

8.10.5 Addressing

The address range of the 8xIQ-Sense module is 16 bytes I/O.

This is independent of the choice of channel profiles on the connected device (i.e. the IQ profile IDs in HW Config).

Access to memory areas

A direct association exists between the number of the channel to which the IQ-Sense device is connected (terminal) and the input and output data area of the module. Based on the address range, the following addresses can be used to access the memory areas:

$$\text{Address} = \text{module initial address} + (\text{channel no.} \times 2)$$

Example

Module initial address = 280

I/O address for channel 3: 286

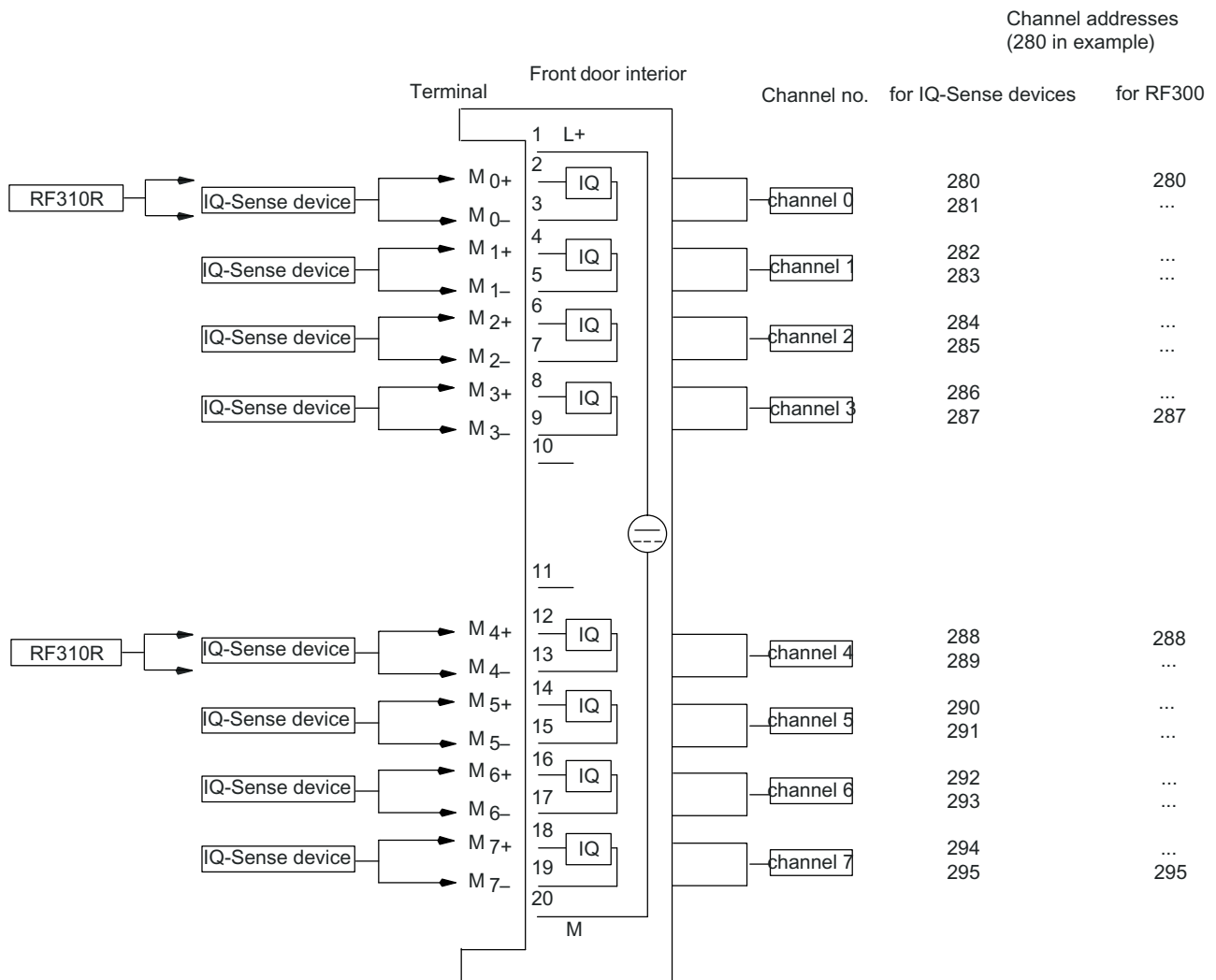

Figure 8-29 8xIQ-Sense module: Assignment of terminal pair to memory area

Note

A maximum of two read/write devices can be operated!

Each read/write device uses channel numbers 0 to 3 or 4 to 7.

8.10.6 Technical data

Voltages and currents	
Rated supply voltage	24 V DC
Reverse polarity protection	yes
Galvanic isolation	
<ul style="list-style-type: none"> • Between the channels • Between channels and backplane bus 	<p>no</p> <p>yes</p>
Permissible potential difference	
Between different circuits	75 V DC / 60 V AC
Insulation tested at	500 V DC
Current input	
<ul style="list-style-type: none"> • from the backplane bus • from L+ power supply 	<p>120 mA typical</p> <p>500 mA max.</p>
Module power loss	2.5 W typical
Module-specific data	
Number of channels	8
Channels for RFID systems	2
Cable length, unshielded	50 m max.
Dimensions and weight	
Dimensions w x h x d (mm)	40 x 125 x 120
Weight	Approx. 235 g

System diagnostics

9.1 Error codes

Error codes of the RF300 readers

Flashing of red LED on reader	Error code (hexadecimal)	Description
00	00	no error
02	01	Presence error, possible causes: <ul style="list-style-type: none"> • The active command was not carried out completely • The tag has left the field while the command is being processed • Communication fault between reader and tag
05	05	Parameterization error, possible causes: <ul style="list-style-type: none"> • Unknown command • Incorrect parameter • Function not allowed
06	06	Air interface faulty
12	0C	The tag memory cannot be written, possible causes: <ul style="list-style-type: none"> • Hardware fault (memory faulty) • Memory write-protected (corresponding OTP area has already been written)
13	0D	Error in the specified memory address (access attempted to non-existent or non-accessible memory areas).
19	13	Buffer overflow: Insufficient buffer available in the reader for saving the command
20	14	Major system fault (hardware fault)
21	15	Parameter assignment error: faulty parameter in RESET command
25	19	Previous command is still active
28	1C	Antenna is already switched off/Antenna is already switched on
30	1E	Incorrect number of characters in frame
31	1F	Running command cancelled by "RESET" command

9.2 Diagnostics functions

9.2.1 Overview

Extended diagnostic functions with SIMATIC RF300 @ FB 45-Tabellen müssen noch hier reinverlinkt werden

With SIMATIC RF300, extended diagnostic functions are available which simplify commissioning and maintenance.

This diagnostics data is accessed using the SIMATIC function blocks via the SLG Status and MDS Status commands. These two commands can each be called in various modes (subcommands) for which corresponding data structures (UDTs) are defined.

Table 9- 1 In RF300 mode

Command	Mode (subcommand)	Meaning
SLG status	01	Hardware and firmware configuration, parameterization status
	06	Communication error counter, current command status
MDS status	01	Serial number of the tag (UID), memory configuration EEPROM write-protection status
	02	Serial number of the tag (UID), HF field strength value, communication error counter, presence counter (duration)

Overview of the diagnostic functions

Table 9- 2 In ISO mode

Command	Mode (subcommand)	Meaning
SLG status	01	Hardware and firmware configuration, parameterization status
MDS status	03	Serial number of the tag (UID), recognized tag type in the field (number = tag - type, see reset parameter "ftim"), memory configuration, write protect status (OTP), size and number of blocks in the user memory

9.2.2 Reader diagnostics with SLG Status

The SLG STATUS command can be used to scan the status and diagnostics data of the reader.

SLG STATUS (mode 01), corresponds to UDT 110

Name	Type	Possible values	Comment
hardware	char	(31 to 38 hex)	Type of hardware
hardware_version	word	0 to FF hex 0 to FF hex	HW version = Version (high byte): Unused = Version (low byte)
loader_version	word	0 to FF hex 0 to FF hex	Version of loader = Version (high byte) = Version (low byte)
firmware	char	0 to FF hex	Type of firmware
firmware_version	word	0 to FF hex 0 to FF hex	Firmware version = Version (high byte) = Version (low byte)
driver	char	31 hex	Type of driver 3964R
driver_version	word	0 to FF hex 0 to FF hex	Version of driver = Version (high byte) = Version (low byte)
interface	byte	01 hex 02 hex	Interface type = RS422 = RS232 (only RF380R)
baud	byte	01 hex 03 hex 05 hex	Baud rate = 19.2 Kbaud = 57.6 Kbaud = 115,2 Kbaud
distance_limiting_SLG	byte	This variable is only provided for the RF380R. Users are therefore able to check the output power actually set. An incorrect value in the parameter "distance_limiting" of the RESET message frame results in the default setting "05".	
			Transmit power
		02 hex	0.5 W
		03 hex	0.75 W
		04 hex	1,0
		05 hex	1.25 W (default)
		06 hex	1.5 W
		07 hex	1.75 W
multitag_SLG	byte		Number of MDSes (Multitag/Bulk) that can be processed in the antenna field
		01 hex	= Single tag mode

Name	Type	Possible values	Comment
field_ON_time_SLG	byte	00 hex 01 hex 03 hex 04 hex 05 hex 06 hex 07 hex	RF300 transponder ISO transponder (non-specific) ISO my-d (Infineon SRF 55V10P) ISO (Fujitsu MB89R118) ISO I-Code SLI (Philips SL2 ICS20) Tag-it HFI (Texas Instruments) ISO (ST LRI2K)
status_ant	byte	01 hex 02 hex	Status of antenna = Antenna On = Antenna Off
MDS_control	byte	00 hex 01 hex	Presence mode = Operation without presence message = Operation with presence message

SLG STATUS (mode 06), corresponds to UDT 280

Name	Type	Possible values	Comment
FZP	byte	0 to FF hex	= Error counter, passive (errors during idle time)
ABZ	byte	0 to FF hex	= Abort counter
CFZ	byte	0 to FF hex	= Code error counter
SFZ	byte	0 to FF hex	= Signature error counter
CRCFZ	byte	0 to FF hex	= CRC error counter
BSTAT	byte	0 to FF hex	= Current command status
ASMFZ	byte	0 to FF hex	= Interface problems to host (ASM/PC) parity, BCC, frame error

Note

All counter values are reset after reading (= SLG STATUS command executed).

Explanations:

- "FZP": Counts interference pulses when communication is not taking place with a transponder. (e.g. EMC interference caused by contactors, motors, etc.). However, counter values can also be generated when a tag is located at the edge of the field even when there is no external interference.
- "ABZ", "CFZ", "SFZ" and "CRCFZ" are counters for protocol errors which may occur during reader-tag communication. This can be caused by unsuitable reader/tag positioning (e.g. tag on field boundary, several data carriers in the field) or an external electromagnetic interference.

To ensure clear diagnosis of the quality of communication, it is recommended that an SLG STATUS command (mode 06) is executed following receipt of the presence command to reset the error counter.

The protocol error counters are not mutually independent. If a code error (CFZ) occurs, this will cause a signature (SFZ) or CRC- (CRCFZ) error.

- "BSTAT" is the status for the most recently executed command. A value other than 0 means that the previous command was repeated by the reader due to faults (see above).
- "ASMFZ" signals line-conducted communication interference between the communication module (ASM) and the reader. Faults of this type can be caused by contact problems on the connector or the cable connection.

9.2.3 Transponder diagnostics with MDS Status

The MDS STATUS command can be used to scan the status and diagnostics data of the transponder that is located within the antenna field.

MDS Status (mode 01), corresponds to UDT 260, only for RF300 tags

Name	Type	Possible values	Comment
UID	array[1...8] byte	0000000055555555 hex to 00000000 FFFFFFFF hex	Unique identifier = b0-31: 4 byte TAG ID, b32-63: 0
MDS_type	byte	01 hex 02 hex 03 hex 04 hex	Tag memory configuration = Transponder without FRAM = Transponder with FRAM 8 KB = Transponder with FRAM 32 KB = Transponder with FRAM 32 KB
Lock_state	byte	0 to FF hex	EEPROM write protection status (use graphic from UDT260 here)

MDS Status (mode 02), corresponds to UDT 270, only for RF300 tags

Name	Type	Possible values	Comment
UID	array[1...8] byte	0000000055555555 hex to 00000000FFFFFFFF hex	Unique identifier = b0-31: 4 byte TAG ID, b32-63: 0
LFD	byte	0 to FF hex	= Value for field strength determined in the tag
FZP	byte	0 to FF hex	= Error counter (passive) → errors during idle time
FZA	byte	0 to FF hex	= Error counter (active)
ANWZ	byte	0 to FF hex	= Presence counter

Note

All counter values are reset when the tag exits the field or when the antenna is switched off.

Explanations:

- "LFD" is a value for the field strength that is determined in the transponder. The lower the value, the higher the field strength.
- "FZP" counts fault pulses when communication with a transponder is not taking place (e.g. electromagnetic interference caused by contactors, motors, etc.). Counter values can also be generated when a transponder is located at the edge of the field even when there is no external interference.
- "FZA" counts errors that can occur during reader-to-transponder communication. This can be caused by unsuitable reader/transponder positioning (e.g. transponder on field boundary, several data carriers in the field) or external electromagnetic interference.
- "ANWZ" is the value for the time that the transponder remains in the field before the MDS STATUS command (mode 02) is executed. A time step is 10 ms. The maximum time that can be recorded is therefore 2.5 s.

MDS STATUS for ISO mode (mode 03) corresponds to UDT 230

Table 9- 3 MDS STATUS for ISO mode

Name	Type	Possible values	Comment
UID	array[1...8] byte	00000000 00000000 hex to FFFFFFFF FFFFFFFF hex	Unique identifier =8 byte UID, MSB first
MDS_type	byte	01 hex 03 hex 04 hex 05 hex 06 hex 07 hex	Tag type (vendor, identification) = ISO general (non-specific or unknown) = my-d (Infineon) = MB89R118 (Fujitsu) = I-Code SLI (NXP) = Tag-it HFI (Texas Instruments) = LRI2K (ST)
IC_version	byte	0 to FF hex	Chip version
size	byte	0 to FF hex	Memory size in bytes Depending on tag type, e.g. my-d: 992 bytes

Name	Type	Possible values	Comment
lock_state	byte	0 to FF hex	Lock status, OTP information: one bit is used per block (4 x 4 bytes or 2 x 8 bytes) (bit = 1: block is locked) e.g. 01 = Block 1 of address FF80 - FF83 is locked or 03 = Block 1 and 2 of address FF80 - FF87 are locked, e.g. for the Philips SL2 ICS20 (MDS D124, D160 or D100). This chip provides a usable memory (112 bytes EEPROM) from address 0000 - 006F (total OTP area 0060 - 006F). In this memory, the locked area corresponds to the addresses 0060 - 0063 or 0060 - 0067
block_size	byte	0 to FF hex	Block size of the transponder Depending on tag type, e.g. my-d: 4 bytes
nr_of_blocks	byte	0 to FF hex	Number of blocks Depending on tag type, e.g. my-d: 248

Appendix

A.1 Certificates and approvals

Certificate	Description
	CE Approval to R&TTE

Notes on CE marking

The following applies to the system described in this documentation:
The CE marking on a device is indicative of the corresponding approval:

DIN ISO 9001 certificate





The quality assurance system for the entire product process (development, production, and marketing) at Siemens fulfills the requirements of ISO 9001 (corresponds to EN29001: 1987).



This has been certified by DQS (the German society for the certification of quality management systems).

EQ-Net certificate no.: 1323-01

Certifications for the United States, Canada, and Australia

Safety

One of the following markings on a device is indicative of the corresponding approval:	
	Underwriters Laboratories (UL) per UL 60950 (I.T.E) or per UL 508 (IND.CONT.EQ)
	Underwriters Laboratories (UL) according to Canadian standard C22.2 No. 60950 (I.T.E) or C22.2 No. 142 (IND.CONT.EQ)
	Underwriters Laboratories (UL) according to standard UL 60950, Report E11 5352 and Canadian standard C22.2 No. 60950 (I.T.E) or UL508 and C22.2 No. 142 (IND.CONT.EQ)
	UL recognition mark

One of the following markings on a device is indicative of the corresponding approval:	
	Canadian Standard Association (CSA) per Standard C22.2. No. 60950 (LR 81690) or per C22.2 No. 142 (LR 63533)
	Canadian Standard Association (CSA) per American Standard UL 60950 (LR 81690) or per UL 508 (LR 63533)

EMC

USA	
Federal Communications Commission Radio Frequency Interference Statement	This equipment has been tested and found to comply with the limits for a Class A digital device, pursuant to Part 15 of the FCC Rules. These limits are designed to provide reasonable protection against harmful interference when the equipment is operated in a commercial environment. This equipment generates, uses, and can radiate radio frequency energy and, if not installed and used in accordance with the instruction manual, may cause harmful interference to radio communications. Operation of this equipment in a residential area is likely to cause harmful interference in which case the user will be required to correct the interference at his own expense.
Shielded Cables	Shielded cables must be used with this equipment to maintain compliance with FCC regulations.
Modifications	Changes or modifications not expressly approved by the manufacturer could void the user's authority to operate the equipment.
Conditions of Operations	This device complies with Part 15 of the FCC Rules. Operation is subject to the following two conditions: (1) this device may not cause harmful interference, and (2) this device must accept any interference received, including interference that may cause undesired operation.

CANADA	
Canadian Notice	This Class A digital apparatus complies with Canadian ICES-003.

AUSTRALIA	
	This product meets the requirements of the AS/NZS 3548 Norm.

A.2 Accessories

CD "RFID Systems Software & Documentation"

The CD contains:

- FB/FC for SIMATIC, 3964R
- Driver for DOS/Windows 95/NT/2000/XP
- C libraries
- PC demonstration program
- RFID documentation in PDF format, especially RFID system manuals, programming instructions and operating instructions

The "RFID Systems Software & Documentation" CD has a user-friendly interface based on HTML. After Start.exe has been called, a window for selecting the RFID system appears:

- RF300
- RF600
- RF-MANAGER
- MOBY
- CM/ASM

After selecting the RFID system, you can navigate to the required information.

Product	Order number
CD "RFID Systems Software & Documentation"	6GT2 080-2AA10

Note

Notes on "RFID system software" and licensing

When purchasing a communication module or an interface module, no software or documentation is supplied. The "RFID Systems Software & Documentation" CD-ROM contains all available FBs/FCs for the SIMATIC, C libraries, demo programs, etc. and needs to be ordered separately. In addition, the CD-ROM contains the complete RFID documentation (German, English and French) in PDF format.

The purchase of a communication module or an interface module includes a payment for the use of the software, including documentation, on the "RFID Systems Software & Documentation" CD-ROM and the purchaser acquires the right to make copies (copy license) insofar as they are required as part of the customer-specific application or development for the plant.

The enclosed contract pertaining to the use of software products against a one-off payment shall apply in addition.

A.3 Connecting cable

In the following chapter, you will find an overview of the connecting cables between the readers and communication modules or PCs.

A.3.1 Reader RF3xxR (RS422) with ASM 452/ASM 473

A reader always occupies two M12 connection sockets on the ASM 452/ASM 473
 A pre-assembled cable therefore ensures easy connection of the reader (see figure below).
 The connecting cable has a length of 2 m (standard) and 5 m. Extensions up to 1000 m are possible with the 6GT2891-0F plug-in cables.

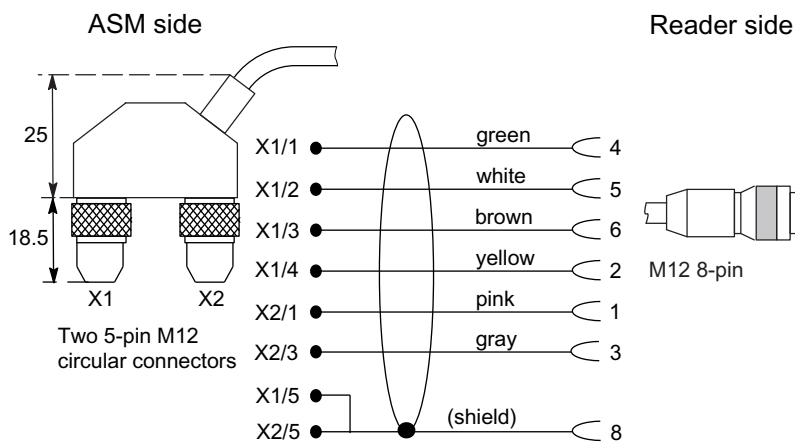

Figure A-1 Connecting cable between ASM 452/473 and RF3xxR reader with RS422 (6GT2891-1CH20)

A.3.2 Reader RF3xxR (RS422) with ASM 456/RF170C/RF180C

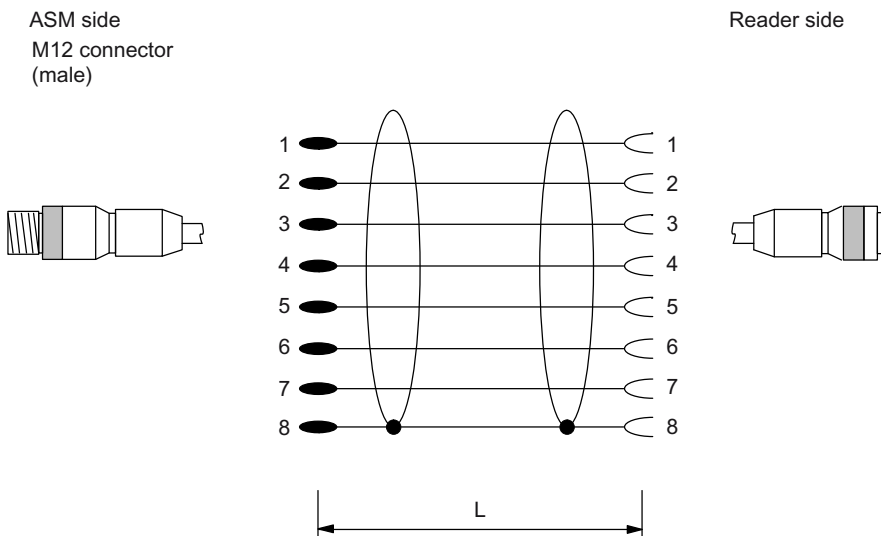

Figure A-2 Connecting cable between ASM 456, RF170C, RF180C and reader RF3xxR (RS422)

Table A- 1 Ordering data

Length L	Order number
2 m	6GT2891-0FH20
5 m	6GT2891-0FH50
10 m	6GT2891-0FN10
20 m	6GT2891-0FN20
50 m	6GT2891-0FN50

A.3.3 Reader RF3xxR (RS422) with ASM 475

Reader connection system

The connecting cable has a length of 2 m (standard) and 5 m. Extensions up to 1000 m are possible with the 6GT2891-0F plug-in cables.

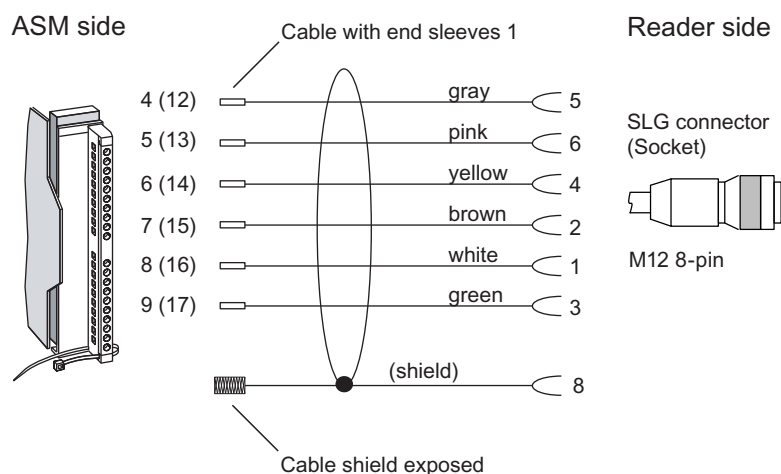

¹ 6GT2891-0E... with straight SLG connector (standard)

Figure A-3 Installation of connecting cable between ASM 475 and RF300 reader with RS 422

A.3.4 RF310R and IQ-Sense

The connecting cable is available in lengths of 5 m (standard) and 10 m.

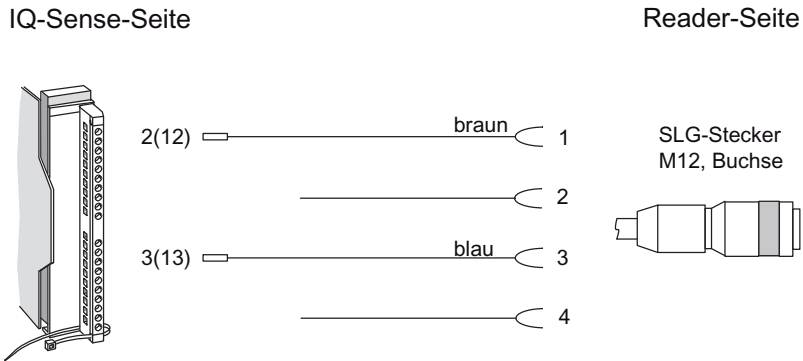

Figure A-4 Configuration of connecting cable from 8xIQ-Sense to RF310R

Length	Order number
5 m	3RX8000-0CB42-1AF0
10 m	3RX8000-0CB42-1AL0

A.3.5 Reader RF380R (RS232) - PC

The connecting cable (6GT2891-0KH50) is 5 m long.

Special feature of the cable: additional branch for the power supply.

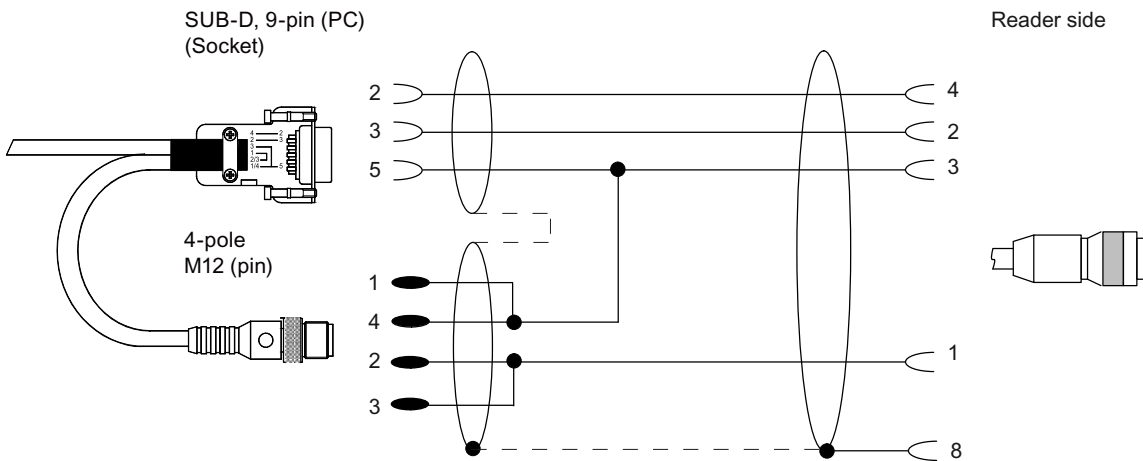

Figure A-5 Connecting cable RF380R (RS232) to the PC

Suitable power supply unit: e.g. wide-range power supply unit

Table A- 2 Ordering data for wide-range power supply unit

Wide-range power supply unit for SIMATIC RF-systems (100 - 240 V AC / 24 V DC / 3 A) with 2 m connecting cable with country-specific plug	EU: 6GT2898-0AA00 UK: 6GT2898-0AA10 US: 6GT2898-0AA20
---	---

A.4 Ordering data

RF300 components

Table A- 3 RF300 reader

Readers	Description	Order number
RF310R (IQ-Sense)	<ul style="list-style-type: none"> • With IQ-Sense interface • IP 67 • Operating temperature: -25 °C to +70 °C • Dimensions: 55 x 75 x 30 (L x W x H, in mm) • with integrated antenna 	6GT2801-0AA00
RF310R (RS422)	<ul style="list-style-type: none"> • With RS422 interface (3964R) • IP 67 • Operating temperature: -25 °C to +70 °C • Dimensions: 55 x 75 x 30 (L x W x H, in mm) • with integrated antenna • ISO 15693 compatible 	6GT2801-1AB10
RF340R	<ul style="list-style-type: none"> • With RS422 interface (3964R) • IP 67 • Operating temperature -25 °C ... +70 °C • Dimensions 75 x 91 x 41 (L x W x H in mm) • with integrated antenna 	6GT2801-2AB10
RF350R	<ul style="list-style-type: none"> • With RS422 interface (3964R) • IP 65 • Operating temperature: -25 °C ... +70 °C • Dimensions: 75 x 96 x 41 (L x W x H, in mm) • For pluggable antennas ANT 1, ANT 12, ANT 18, ANT 30 	6GT2801-4AB10
RF380R	<ul style="list-style-type: none"> • With RS422 interface (3964R) • IP 67 • Operating temperature: -25 °C ... +70 °C • Dimensions: 160 x 96 x 40 (L x W x H, in mm) • with integrated antenna • ISO 15693 compatible 	6GT2801-3AB10

Table A- 4 Antennae

Antenna	Description	Order number
ANT 1	<ul style="list-style-type: none"> IP67 Operating temperature: -25 °C to +70 °C Dimensions: 75 x 75 x 20 (L x W x H, in mm) 	6GT2398-1CB00
ANT 12	<ul style="list-style-type: none"> IP67 Operating temperature: -25 °C to +70 °C Dimensions: M18 x 1.0 x 55 	6GT2 398-1CC00
ANT 18	<ul style="list-style-type: none"> IP67 (front) Operating temperature -25 °C to +70 °C Dimensions: M18 x 50 (Ø x L in mm) 	6GT2398-1CA00
ANT 30	<ul style="list-style-type: none"> IP67 (front) Operating temperature -25 °C to +70 °C Dimensions: M30 x 58 (Ø x L in mm) 	6GT2398-1CD00

Table A- 5 RF300 transponder

RF300 transponder	Description	Order number
RF320T	<ul style="list-style-type: none"> IP67 Memory size: 20 byte EEPROM Operating temperature: -25 °C to +85 °C Dimensions: 27 mm x 4 mm (Ø x H in mm) 	6GT2800-1CA00
RF340T	<ul style="list-style-type: none"> IP68 Memory size: 8 KB FRAM Operating temperature: -25 °C to +85 °C Dimensions: 48 x 25 x 15 (L x W x H, in mm) 	6GT2800-4BB00
RF350T	<ul style="list-style-type: none"> IP68 Memory size: 32 KB FRAM (read/write) and 4 byte EEPROM (read only) Operating temperature: -25 °C ... +85 °C Dimensions: 50 x 50 x 20 (L x W x H, in mm) 	6GT2800-5BD00
RF360T	<ul style="list-style-type: none"> IP67 Memory size: 8 KB FRAM (read/write) and 4 byte EEPROM (read only) Operating temperature: -25 °C ... +75 °C Dimensions: 85.8 x 54.8 x 2.5 (L x W x H, in mm) 	6GT2800-4AC00
RF370T (32 KB FRAM)	<ul style="list-style-type: none"> IP68 Memory size: 32 KB FRAM Operating temperature: -25 to +85 °C Dimensions: 75 x 75 x 40 (L x W x H, in mm) 	6GT2800-5BE00

RF300 transponder	Description	Order number
RF370T (64 KB FRAM)	<ul style="list-style-type: none"> • IP68 • Memory size: 64 KB FRAM • Operating temperature: -25 °C to +85 °C • Dimensions: 75 x 75 x 40 (L x W x H, in mm) 	6GT2800-6BE00
RF380T	<ul style="list-style-type: none"> • IP68 • Memory size 32 KB FRAM (read/write) and 4 byte EEPROM • Operating temperature -25 ... +200 °C (cyclic) • Dimensions: 114 x 83 (Ø x H in mm) 	6GT2800-5DA00

Table A- 6 ISO transponder

ISO transponder	Description	Order number
MDS D100	<ul style="list-style-type: none"> • IP68 • Memory size: 112 byte EEPROM • Operating temperature: -25 ... +80 °C • Dimensions: 85.6 x 54 x 0.9 (L x W x H, in mm) • ISO card 	6GT2600-0AD10
MDS D124	<ul style="list-style-type: none"> • IP67 • Memory size: 112 byte EEPROM user memory • Operating temperature: -25 ... +125 °C • Dimensions: 27 mm x 4 mm (Ø x H in mm) 	6GT2600-0AC00
MDS D139	<ul style="list-style-type: none"> • IP68 • Memory size: 112-byte user memory • Operating temperature: up to +200 °C/+220 °C [heat-resistant (r/w)] • Dimensions: 85 x 15 (Ø x H in mm) 	6GT2600-0AA10
MDS D160	<ul style="list-style-type: none"> • IP68 (24 hours, 2 m, +20 °C) • Memory size: 112 byte user memory • Operating temperature: -25 °C...+70 °C • Dimensions: 16 x 3 ±0.1 (Ø x H in mm) • Laundry tag for cyclical applications (r/w) 	6GT2600-0AB10
MDS D324	<ul style="list-style-type: none"> • IP67 • Memory size: 992 byte EEPROM user memory • Operating temperature: -25 °C...+125 °C • Dimensions: 27 x 4 (Ø x H in mm) 	6GT2600-3AC00
MDS D421	<ul style="list-style-type: none"> • IP67/x9K • Memory size: 2000 byte user memory • Operating temperature: -25 °C to +85 °C • Dimensions: 10 x 4.5 (Ø x H in mm) 	6GT2600-4AE00
MDS D424	<ul style="list-style-type: none"> • IP67 • Memory size: 992 byte EEPROM user memory • Operating temperature: -25 °C ...+125 °C • Dimensions: 27 x 4 (Ø x H in mm) 	6GT2600-4AC00

ISO transponder	Description	Order number
MDS D428	<ul style="list-style-type: none"> IP68; IP x9K Memory size: 2000 byte FRAM user memory Operating temperature: -25 °C ...+85 °C Dimensions (D x H): 18 mm x 20 mm (without thread), tolerance 1 mm; M8 thread 	6GT2600-4AK00
MDS D460	<ul style="list-style-type: none"> IP68 Memory size: 2000 byte FRAM user memory Operating temperature: -25 °C ...+85 °C Dimensions: 16 x 3 ±0.1 (Ø x H in mm) 	6GT2600-4AB00

Table A-7 Communication modules/interface modules

ASM/ communication module	Description	Order number
ASM 452	<ul style="list-style-type: none"> for PROFIBUS DP-V1, 1x RF3xxR with RS422 interface without connector for 24 V DC and PROFIBUS 	6GT2002-0EB20
ASM 456	<ul style="list-style-type: none"> for PROFIBUS DP-V1 For connecting as many as 2 readers 	6GT2002-0ED00
ASM 473	1x RF3xxR reader with RS422 can be connected	6GT2002-0HA10
ASM 475	<ul style="list-style-type: none"> For SIMATIC S7 2 x readers RF3xxR with RS422 can be connected in parallel without a front connector 	6GT2002-0GA10
RF170C	Communication module, 1 unit	6GT2002-0HD00
	Connection module, 1 unit	6GT2002-1HD00
RF180C	RF180C communication module max. 2 SLGs or readers can be connected	6GT2002-0JD00
	Connection block M12, 7/8" PN	6GT2002-1JD00
	Push-pull connection block, RJ45	6GT2002-2JD00
RF182C	RF182C communication module Max. 2 SLGs or readers can be connected	6GT2002-0JD10
	Connection block M12, 7/8" (5-pole)	6GT2002-1JD00
	Connection block M12, 7/8" (4-pole)	6GT2002-4JD00
	Push-pull connection block, RJ45	6GT2002-2JD00
8xIQ-Sense	<ul style="list-style-type: none"> IQ-Sense SM338 for S7-300 and ET200M for the connection of up to 8xIQ-Sense sensors Optical sensors, ultrasonic sensors and RF identification systems can be connected. 	6ES7 3387XF000AB0

Accessories

Table A- 8 Accessories for RF300 reader

Readers	Accessories	Order number
RF380R	Connecting cable RS232 to PC	6GT2891-0KH50

Table A- 9 Accessories for RF300 tags

Tag	Accessories	Order number
RF360T	Spacers	6GT2190-0AA00
	Fixing pocket	6GT2190-0AB00
RF380T	Holder (short version)	6GT2090-0QA00
	Holder (long version)	6GT2090-0QA00-0AX3
	Covering hood	6GT2090-0QB00
	Universal holder	6GT2590-0QA00

Table A- 10 Accessories for ISO tags

MDS	Accessories	Order number
MDS D100	Spacers	6GT2190-0AA00
	Fixing pocket	6GT2190-0AB00
	Fixing pocket (cannot be mounted directly on metal)	6GT2390-0AA00
MDS D139	Spacer [85 mm x 30 mm (Ø x H in mm)]	6GT2690-0AA00

Table A- 11 Connecting cable accessory - ASM/communication module to reader

ASM - Reader	Description	Order number
ASM 452/ ASM 473 and reader RF3xxR with RS422	Length	
	2 m	6GT2891-1CH20
	5 m	6GT2891-1CH50
ASM 456/RF170C/ RF180C and reader RF3xxR (RS422)	Length	
	2 m	6GT2891-0FH20
	5 m	6GT2891-0FH50
	10 m	6GT2891-0FN10
	20 m	6GT2891-0FN20
ASM 475 and reader	Length	
	2 m	6GT2891-0EH20

ASM - Reader	Description	Order number
RF3xxR (RS422)	5 m	6GT2891-0EH50
8xIQ-Sense and RF310R	Length	
	5 m	3RX8000-0CB42-1AF0
	10 m	3RX8000-0CB42-1AL0

Table A- 12 RFID accessories, general

RFID accessories, general	Order number
CD "RFID Systems Software & Documentation"	6GT2 080-2AA10
Wide-range power supply unit for SIMATIC RF systems (100 - 240 V AC/24 V DC/3 A) with 2 m plug-in cable with country-specific connector	EU: 6GT2898 0AA00 UK: 6GT2898 0AA10 US: 6GT2898 0AA20

A.5 Service & Support

Contact partner

If you have any further questions on the use of our products, please contact one of our representatives at your local Siemens office.

The addresses are found on the following pages:

- On the Internet (www.siemens.com/automation/partner)
- In Catalog CA 01
- In Catalog FS 10 specially for factory automation sensors

Technical Support

You can access technical support for all IA/DT projects via the following:

- Phone: + 49 (0) 180 5050 222
(€ 0.14 /min. from the German landline network, deviating mobile communications prices are possible)
- E-mail (<mailto:support.automation@siemens.com>)
- Internet: Online support request form: (www.siemens.com/automation/support-request)

Service & support for industrial automation and drive technologies

You can find various services on the Support homepage (www.siemens.com/automation/service&support) of IA/DT on the Internet.

There you will find the following information, for example:

- Our newsletter containing up-to-date information on your products.
- Relevant documentation for your application, which you can access via the search function in "Product Support".
- A forum for global information exchange by users and specialists.
- Your local contact for IA/DT on site.
- Information about on-site service, repairs, and spare parts. Much more can be found under "Our service offer".

RFID homepage

For general information about our identification systems, visit RFID homepage (www.siemens.com/simatic-sensors/rf).

Technical documentation on the Internet

A guide to the technical documentation for the various products and systems is available on the Internet:

SIMATIC Guide manuals (www.siemens.com/simatic-tech-doku-portal)

Online catalog and ordering system

The online catalog and the online ordering system can also be found on the A&D Mall homepage. (www.siemens.com/automation/mall)

Training center

We offer appropriate courses to get you started. Please contact your local training center or the central training center in

D-90327 Nuremberg.

Phone: +49 (0) 180 523 56 11

(€ 0.14 /min. from the German landline network, deviating mobile communications prices are possible)

For information about courses, see the SITRAIN homepage (www.sitrain.com).

Glossary

Index

8

- 8xIQ-Sense module
 - Addressing, 244
 - Indicators, 241
 - Ordering data, 241

A

- Antennae
 - Minimum clearances, 121
- Application Planning
 - SIMATIC RF300, 27
- Approvals, 255
- ASM 452
 - Configuration, 214
 - Indicators, 213
 - Operating mode, 215
 - Ordering data, 212
 - Pin assignments, 213
 - PROFIBUS address and terminating resistor, 217
 - PROFIBUS configuration, 214
 - Reader connection system, 215
- ASM 473
 - Design and function, 221
 - Dimensions, 228
 - Features, 221
 - Hardware configuration, 226
 - Maximum configuration of an ET 200X, 226
 - Notes on operation, 224
 - Ordering data, 222
 - Pin assignments, 223
 - Reader connection system, 226
 - Technical specifications, 227
- ASM 475
 - Assignment for connecting cable, 234, 259
 - Cable installation, 235
 - Design and function, 229
 - Function of the LEDs, 231
 - Indicators, 231
 - Ordering data, 230
 - Pin assignment, 234, 259
 - Status display with LEDs, 232

C

- Cabinet configuration, 92
- Cable, 258
 - Reader - ASM, 258
 - Shielding, 96
- Calculation example, 39
- Certificates, 255
- Chemical resistance of the MDS
 - MDS D139, 83
 - MDS D160, 86
- Combinations
 - Reader-tag, 18
- Communication modules, 17, 209
- Communication time
 - Calculating, 37
- Connecting cable
 - Reader-communication module/ASM/PC, 258
- Contact partner, 266
- Conventions, 12, 20
- Coupling paths, 91
- Courses, 267
- Customer benefits, 21

D

- Data transmission rate
 - MDS D100, 55
 - MDS D124, 56
 - MDS D139, 57
 - MDS D160, 58
 - MDS D324, 59, 60, 61, 62
 - RF320T, 49
 - RF340T, 50
 - RF350T, 51
 - RF360T, 52
 - RF370T, 53
 - RF380T, 54
- Design
 - System Manual, 11
- Detection area, 35
- Diagnostic functions
 - Transponder, 251
- Direction of motion
 - Transponder, 35
- Display elements

- RF310R reader with IQ-Sense interface, 101
- RF310R reader with RS422 interface, 105, 110, 115, 126
- RF340R reader, 110
- Dwell time
 - Transponder, 36
- Dynamic mode, 36
 - Dwell time of the transponder, 36

E

- Electromagnetic compatibility
 - Coupling paths, 91
- Electromagnetic interference, 89
- EMC Directives
 - Propagation of electromagnetic interference, 89
- EMC Guidelines, 256
 - Avoiding interference, 94
 - Basic Rules, 88
 - Cabinet configuration, 92
 - Cable shielding, 97
 - Definition, 87
 - Equipotential bonding, 95
 - Overview, 86
- Equipotential bonding, 95
- Error codes
 - Readers, 247

F

- FC 45, 248
- Features of ASM 452 interface module
 - Area of application, 211
- Field data
 - RF310R reader, 44
- Fields of application, 20
- Fixing pocket
 - for MDS D100, 174
- Flush-mounting
 - of transponders and readers, 64

H

- High-performance, 16

I

- Inductive alternating field, 27
- Input parameter, 209
- Installation

- Several readers, 64
- Installation guidelines, 62
- Interface modules, 209
- Interference sources
 - Electromagnetic, 90
- IQ-Sense interface
 - Pin assignment, 100, 243
- ISO functionality, 99

L

- LEDs
 - For MOBY, 223
 - for PROFIBUS DP, 223
- Low-performance, 16

M

- Main applications, 20
- MDS STATUS, 248
- Medium-performance, 16
- Memory configuration of the RF300 tags, 134
- Metal
 - Influence on the transmission window, 66
- Metal-free area
 - Reader RF310R, 101, 106
 - Reader RF340R, 110, 127
 - Transponder RF320T, 136
 - Transponder RF340T, 140
 - Transponder RF350T, 143
 - Transponder RF360T, 147
 - Transponder RF370T, 152
 - Transponder RF380T, 159
- Minimum clearances
 - Antenna to antenna, 121
- Minimum distance
 - Antenna to antenna, 48
 - Reader to reader, 48
 - Transponder to transponder, 47

O

- Ordering data, 261
 - 8xIQ-Sense module, 241
 - Antennae, 262
 - Interface modules/communication Modules, 264
 - Overview, 261
 - Readers, 261
 - RF300 transponder, 262
 - RF310R with IQ-Sense, 100

P

- Parameterization
 - Function blocks, 209
- PROFIBUS cable
 - Stripped lengths, 228

R

- Read/write distance, 27
- Reader RF310R
 - Display elements, 101
 - Metal-free area, 101, 106
 - Pin assignment of IQ-Sense interface, 100
- Reader RF340R
 - Metal-free area, 110, 127
- Readers, 99
 - Mounting, 64
- Reducing interference due to metal, 63
- Reduction of field data by metal
 - RF340R, 68, 69
 - RF350R with ANT 1, 70, 71, 72
 - RF350R with ANT 18, 72, 73
 - RF350R with ANT 30, 74
 - RF380R, 67, 75, 76
- Resistance to chemicals
 - Transponder, 77
- RF310R reader, 100, 104, 113, 125
 - Characteristics, 100, 104, 113, 125
 - Minimum distance, 102, 106
 - Pin assignment of IQ-Sense interface, 243
- RF340R reader, 109
 - Characteristics, 109
- RF370T transponder/32 KB FRAM
 - Technical specifications, 154
- RFID systems
 - Overview, 15

S

- Selection criteria
 - SIMATIC RF300 components, 27
- Shielding, 97
- SIMATIC RF300
 - Diagnostic functions, 248
- SLG STATUS, 248
- Spacers, 175
- Static mode, 35
 - Dwell time of the transponder, 36
- System diagnostics
 - MDS status, 251
 - Overview, 248

- System overview
 - RFID systems, 15

T

- Technical documentation
 - On the Internet, 267
- Technical specifications
 - RF370T transponder/32 KB FRAM, 154
 - Transponder RF320T, 138
 - Transponder RF340T, 141
 - Transponder RF350T, 144, 150
 - Transponder RF360T, 150
- Technical Support, 266
- Time constants, 38, 39
- Tolerance of pallet side transport, 40
- Tolerance of pallet transport height, 39
- Tracking
 - Tolerance, 32
- Tracking tolerances, 32
- Training, 267
- Transmission gaps, 41
- Transmission window
 - ANT18 and ANT30 (RF350R), 30
 - Impact of metal, 66
 - RF310R reader and ANT1 (RF350R), 28
 - RF340R reader, 29
 - RF380R reader, 31
 - Width, 32
- Transponder
 - Detection area, 35
 - Directions of motion, 35
 - Dwell time, 36
 - Mounting on metal, 65
 - Resistance to chemicals, 77
- Transponder RF320T
 - Characteristics, 136
 - Metal-free area, 136
 - Technical specifications, 138
- Transponder RF340T
 - Characteristics, 139
 - Metal-free area, 140
 - Technical specifications, 141
- Transponder RF350T
 - Characteristics, 142
 - Metal-free area, 143
 - Technical specifications, 144
- Transponder RF360T
 - Characteristics, 147
 - Metal-free area, 147
 - Technical specifications, 150
- Transponder RF370T

Characteristics, 151
Metal-free area, 152
Transponder RF380T
Metal-free area, 159

U

User data
Calculate maximum number, 37
Calculating, 37

