

8.13 MDS D339

8.13.1 Characteristics

MDS D339	Characteristics	
	Area of application	<p>Applications in production automation with high temperature demands (up to +220 °C)</p> <p>Typical application areas:</p> <ul style="list-style-type: none"> • Paintshops and their preparatory treatments • Primer coat, electrolytic dip area, cataphoresis with the associated drying furnaces • Top coat area with drying furnaces • Washing areas at temperatures > 85 °C • Other applications with higher temperatures
	Memory size	992 bytes of EEPROM user memory
	Write/read range	See section Field data of ISO transponders (MDS D) (Page 52).
	Mounting on metal	Yes, with spacer
	ISO standard	ISO 15693
	Degree of protection	IP68/IPx9K

8.13.2 Ordering data

Table 8- 31 Ordering data for MDS D339

	Article number
MDS D339	6GT2600-3AA10

Table 8- 32 Ordering data for MDS D339 accessories

	Article number
Spacer	6GT2690-0AA00
Quick change holder (Ø x H): 22 x 60 mm	6GT2690-0AH00
Quick change holder (Ø x H): 22 x 47 mm	6GT2690-0AH10

8.13.3 Mounting on metal

Direct mounting of the MDS D139/D339 on metal is not allowed. A distance of ≥ 30 mm is recommended. This can be achieved using spacers (see "Ordering data (Page 303)").

Mounting on metal

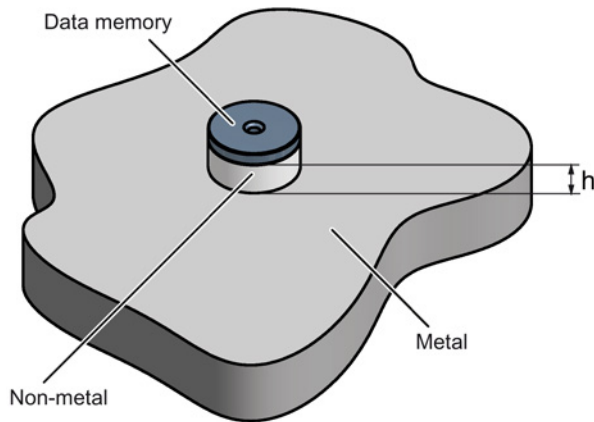

$h \geq 30$ mm

Figure 8-28 Mounting the MDS D139/D339 on metal with spacer

Flush-mounting

It is possible to mount the MDS D139/D339 in metal. With large antennas, for example ANT D5, this leads to a reduction of ranges.

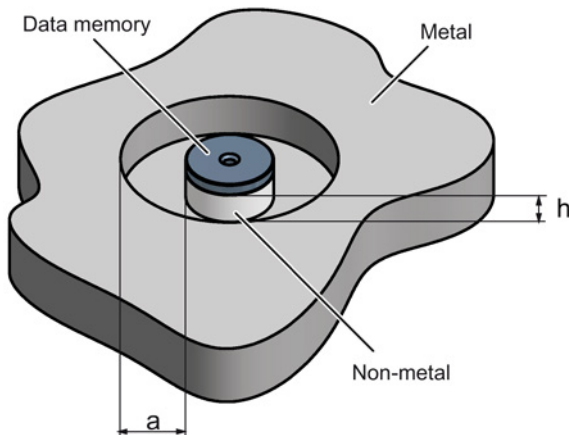

$h \geq 30$ mm

$a \geq 100$ mm

Figure 8-29 Flush-mounting of the MDS D139/D339 in metal with spacer

Note**Going below the distances**

If the distances (a and h) are not observed, a reduction of the field data results. It is possible to mount the MDS with metal screws (M5). This has no tangible impact on the range. It is recommended that a test is performed in critical applications.

8.13.4 Cleaning the mobile data memory

Note

Do not clean the transponder with mechanical tools, sand-blasting or pressure hose. These cleaning methods result in damage to the transponder.

Clean the transponder only with the cleaning agents listed in the section "Chemical resistance of the MDS".

8.13.5 Technical specifications

Table 8- 33 Technical specifications of MDS D339

6GT2600-3AA10	
Product type designation	SIMATIC MDS D339
Memory	
Memory configuration	
• UID	• 8 bytes
• User memory	• 992 bytes EEPROM
• OPT memory	• 16 bytes (EEPROM)
Read cycles (at < 40 °C)	> 10 ¹⁴
Write cycles (at < 40 °C)	> 10 ⁶
Data retention time (at < 40 °C)	> 10 years
Write/read distance (S ₉)	Dependent on the reader used, see section "Field data of ISO transponders (MDS D) (Page 52)"
MTBF (Mean Time Between Failures)	228 years

6GT2600-3AA10

Mechanical specifications**Housing**

• Material	• PPS
• Color	• Black
Recommended distance to metal	≥ 30 mm
Power supply	Inductive, without battery

Permitted ambient conditions**Ambient temperature**

• During operation	• -25 to +220 °C
	• from +125 °C: 20% reduction in the limit distance
	• from +140 °C: No processing possible
	• at +200 °C: Tested up to 5000 hours or 6000 cycles
	• at +220 °C: Tested up to 2000 hours or 2000 cycles
• During transportation and storage	• -40 to +100 °C
Degree of protection to EN 60529	• IP68 2 hours, 2 bar, +20 °C
	• IPx9K steam jet: 150 mm; 10 to 15 l/min; 100 bar; 75 °C
Shock-resistant to EN 60721-3-7 class 7M3	50 g ¹⁾
Vibration-resistant to EN 60721-3-7, class 7M3	20 g ¹⁾
Torsion and bending load	Not permitted

Design, dimensions and weight

Dimensions (Ø x H)	85 x 15 mm
Weight	50 g
Type of mounting	1 x M5 screw ²⁾ 1.5 Nm

¹⁾ The values for shock and vibration are maximum values and must not be applied continuously.

²⁾ For mounting with the spacer (6GT2690-0AA00), use a stainless steel M5 screw to avoid damaging the MDS in high temperatures (expansion coefficient).

8.13.6 Use of the MDS D339 in hazardous areas

The MDS D339 mobile data memory is classed as a piece of simple, electrical equipment and can be operated in Protection Zone 2, Device Group II, Category 3G.

The following requirements of the 94/9/EC directive are met:

- EN 60079-0:2006
- EN 60079-15:2005
- EN 61241-0:2006
- EN 61241-1:2004

Identification



II 3 G Ex nA II T6

li 3 D Ex tD A22 IP68 T 210°C

KEMA 09 ATEX 0133 X



WARNING

Gefahr durch elektrostatische Entladungen

Potential electrostatic charging hazard

Danger potentiel de charges électrostatiques

Note

Installations- und Betriebsbedingungen für den Ex-Schutzbereich:

- a) Der Einsatz des Gerätes in der Nähe von stark ladungserzeugenden Prozessen ist untersagt.
- b) Das Gerät ist mechanisch geschützt zu montieren.
- c) Die Montage muss auf einem geerdeten, leitenden Untergrund erfolgen.
- d) Die Reinigung darf nur mit feuchtem Tuch erfolgen.

Installation and operating conditions for hazardous areas:

- a) Use of the equipment in the vicinity of processes generating high charges is not allowed.
- b) The equipment must be mechanically protected when installed.
- c) Installation must be performed on a grounded and conductive mounting surface.
- d) Cleaning only with a wet cloth

Conditions d'installation et de mise en oeuvre pour la zone de protection Ex :

- a) L'utilisation de l'appareil près de processus générant de fortes charges est interdite.
 - b) L'appareil doit être monté de manière à être protégé mécaniquement.
 - c) Le montage doit être effectué sur un socle conducteur mis à la terre.
 - d) Nettoyage uniquement avec un chiffon humide
-

8.13.7 Dimensional drawing

MDS D339

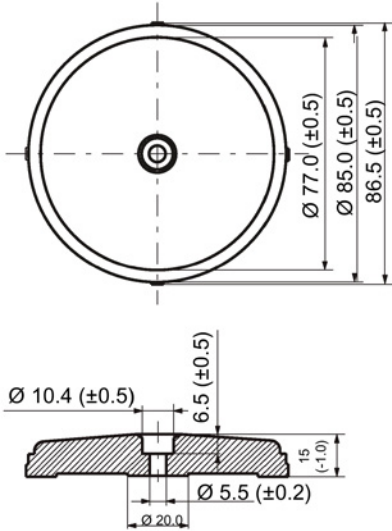



Figure 8-30 Dimension drawing of the MDS D339

Dimensions in mm

8.14 MDS D400

8.14.1 Features

	Characteristics	
	Area of application	Simple identification such as electronic barcode replacement/supplements, from warehouse and distribution logistics right through to product identification.
	Memory size	2000 bytes of FRAM user memory
	Write/read range	See section "Field data of ISO transponders (MDS D) (Page 52)"
	Mounting on metal	Yes, with spacer
	ISO standard	ISO 15693
	Degree of protection	IP67

8.14.2 Ordering data

Table 8- 34 Ordering data of MDS D400

	Article number
MDS D400	6GT2600-4AD00

Table 8- 35 Ordering data of MDS D400 accessories

	Article number
Spacer (in conjunction with fixing pocket 6GT2190-0AB00)	6GT2190-0AA00
Fixing pocket (in conjunction with spacer 6GT2190-0AA00)	6GT2190-0AB00
Fixing pocket (not suitable for fixing directly onto metal)	6GT2390-0AA00

8.14.3 Mounting on metal

Mounting on metal

It is possible to mount the MDS D400 on metal.

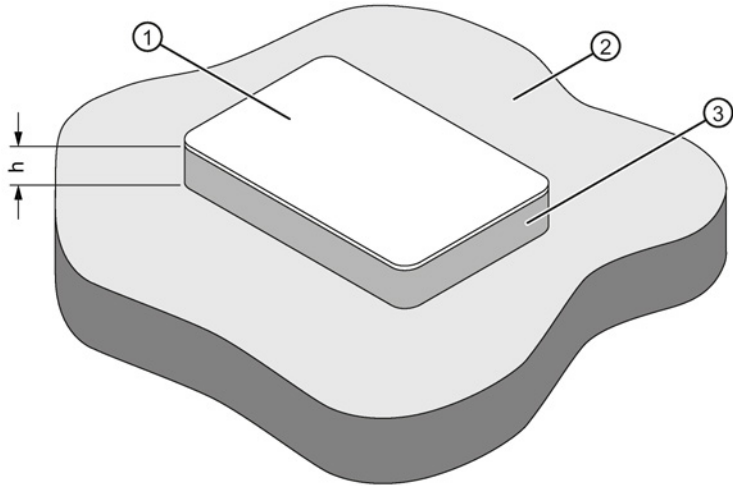

- h \geq 20 mm
- ① Transponder
- ② Metal
- ③ Non-metal

Figure 8-31 Mounting of the MDS D400 on metal with spacer

Flush-mounted in metal

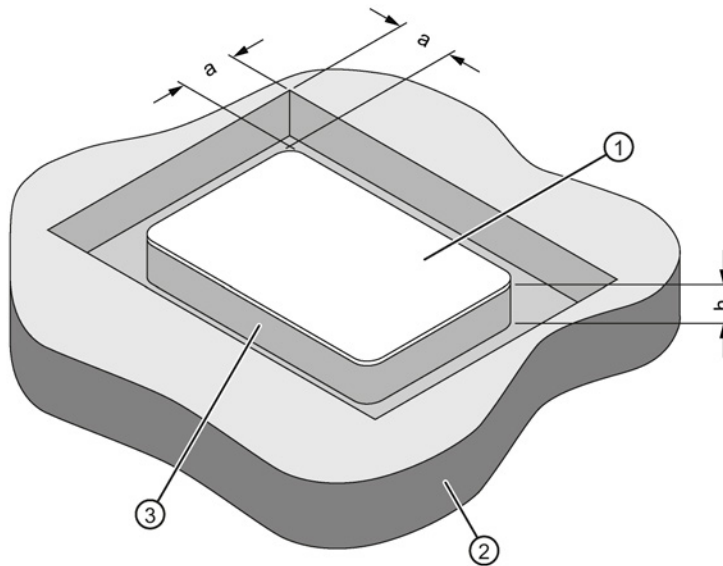

- a ≥ 20 mm
- h ≥ 20 mm
- ① Transponder
- ② Metal
- ③ Non-metal

Figure 8-32 Flush-mounting of MDS D400 in metal with spacer

Note

If the minimum guide values (h) are not observed, this will result in a reduction of the field data.

8.14.4 Technical specifications

Table 8- 36 Technical specifications for MDS D400

6GT2600-1AD00-0AX0	
Product type designation	SIMATIC MDS D400
Memory	
Memory configuration	
• UID	• 8 bytes
• User memory	• 256 bytes FRAM
• OPT memory	• 16 bytes FRAM

6GT2600-1AD00-0AX0	
Read cycles (at < 25 °C)	> 10 ¹²
Write cycles (at < 25 °C)	> 10 ¹²
Data retention time (at < 25 °C)	> 10 years
Write/read distance (S _g)	Dependent on the reader used, see section "Field data of ISO transponders (MDS D) (Page 52)"
MTBF (Mean Time Between Failures)	228 years
Mechanical specifications	
Housing	
• Material	• PVC
• Color	• White
Recommended distance to metal	≥ 20 mm
Power supply	Inductive, without battery
Permitted ambient conditions	
Ambient temperature	
• During operation	• -20 to +60 °C
• During transportation and storage	• -20 to +60 °C
Degree of protection to EN 60529	IP67
Vibration-resistant to EN 60721-3-7, class 7M3	ISO 10373 / ISO 7810 ¹⁾
Torsion and bending load	ISO 10373/ISO 7816-1
Design, dimensions and weight	
Dimensions (L x W x H)	85 x 54 x 0.8 mm
Weight	5 g
Type of mounting	<ul style="list-style-type: none"> • Fixing lug • Glued

¹⁾ The values for vibration are maximum values and must not be applied continuously.

8.14.5 Dimension drawing

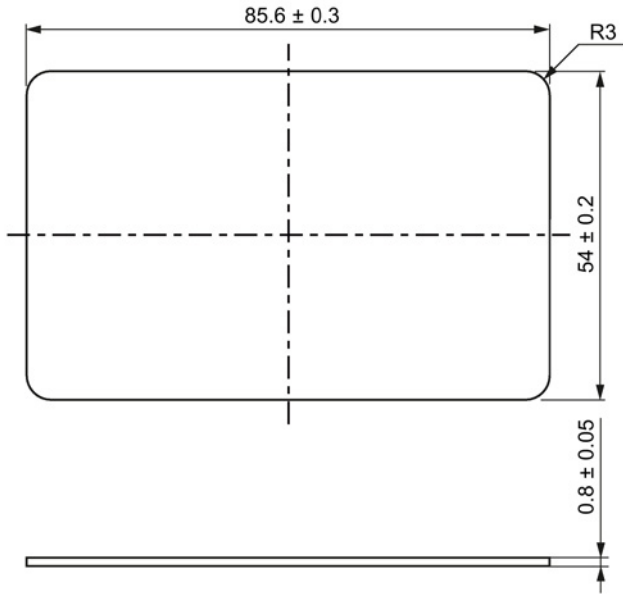



Figure 8-33 Dimensional drawing MDS D400 (dimensions in mm)

DRAFT

8.15 MDS D421

8.15.1 Characteristics

MDS D421	Characteristics	
	Area of application	The MDS D421 is designed for tool coding in accordance with DIN 69873. It can be used wherever small data carriers and exact positioning are required, e.g. tool identification, workpiece holders. The rugged housing of the MDS D421 means that it can also be used in a harsh industrial environment without problems.
	Memory size	2000 bytes of FRAM user memory
	Write/read range	See section "Field data of ISO transponders (MDS D) (Page 52)"
	Mounting on metal	Yes, flush-mounted in metal
	ISO standard	ISO 15693
Degree of protection	IP67/IPx9K	

8.15.2 Ordering data

Table 8- 37 Ordering data of MDS D421

	Article number
MDS D421	6GT2600-4AE00

8.15.3 Mounting on metal

Mounting on metal

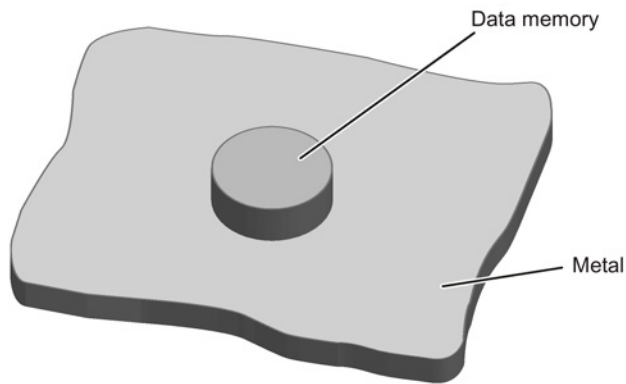

Figure 8-34 Mounting of MDS D421/D521/E623 on metal

Flush-mounting

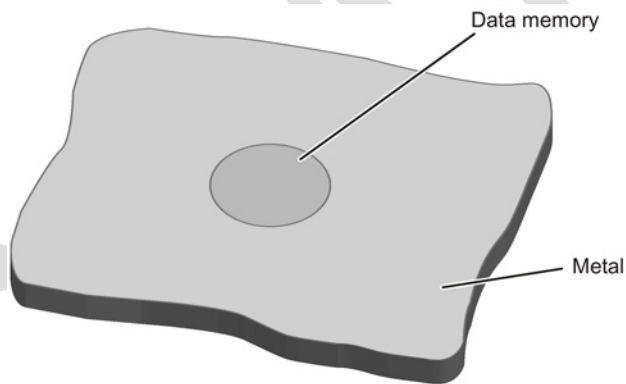

Figure 8-35 Mounting of MDS D421/D521/E623 in metal

Flush-mounting of the MDS in metal with tools

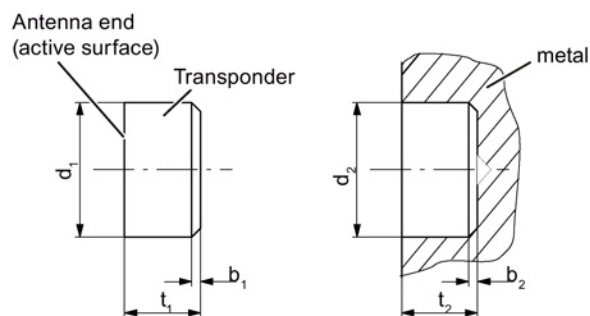

Figure 8-36 Flush-mounting of MDS D421/D521/E623 in metal with tools

b ₁	0.5 x 45°	b ₂	0.3 x 45° or R0.3
d ₁	10 (-0.04... -0.13)	d ₂	10 (+0.09... 0)
t ₁	4.5 (-0 ... -0.1)	t ₂	4.6 (+0.2 ... 0)

All dimensions in mm

Note

Installation instruction

The MDS should not protrude out of the locating hole; it must be flush with the outside contour.

The mounting instructions of the MDS and the conditions associated with the application (e.g. peripheral speed, temperature, and use of coolant) must be observed during the installation.

Mounting information for adhesion

- Drill installation hole
- The adhesive surfaces must be dry, free from dust, oil, stripping agents and other impurities
- Apply adhesive according to the manufacturer's processing instructions
- Press in transponder using your fingers; with antenna side to the outside (see figure above)
- Remove residues of adhesive
- Allow to cure according to the manufacturer's instructions
- Flush-mounting of the transponder in metal with tools

Installation examples

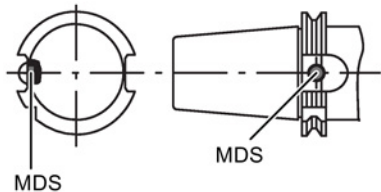

Figure 8-37 Installation example of MDS D421/D521/E623 in a steep cone

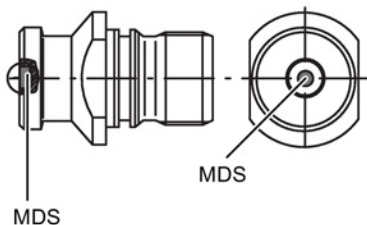

Figure 8-38 Installation example of MDS D421/D521/E623 in a stud bolt

8.15.4 Technical specifications

Table 8- 38 Technical specifications for the MDS D421

6GT2600-4AE00	
Product type designation	SIMATIC MDS D421
Memory	
Memory configuration	
• UID	• 8 bytes
• User memory	• 2000 bytes FRAM
• OPT memory	• 16 bytes FRAM
Read cycles (at < 40 °C)	> 10 ¹²
Write cycles (at < 40 °C)	> 10 ¹²
Data retention time (at < 40 °C)	> 10 years
Write/read distance (S ₉)	Dependent on the reader used, see section "Field data of ISO transponders (MDS D) (Page 52)"
MTBF (Mean Time Between Failures)	228 years

6GT2600-4AE00

Mechanical specifications**Housing**

• Material	• Epoxy resin
• Color	• Black
Recommended distance to metal	≥ 0 mm
Power supply	Inductive, without battery

Permitted ambient conditions**Ambient temperature**

• During operation	• -25 to +85 °C
• During transportation and storage	• -40 to +100 °C

Degree of protection to EN 60529

- IP67
- IPx9K
steam jet: 150 mm; 10 to 15 l/min; 100 bar; 75 °C

Shock-resistant to EN 60721-3-7 class 7M3 100 g ¹⁾Vibration-resistant to EN 60721-3-7, class 7M3 20 g ¹⁾

Torsion and bending load Not permitted

Design, dimensions and weight

Dimensions (Ø x H) 10 x 4.5 mm

Weight Approx. 1 g

Type of mounting Glued²⁾

¹⁾ The values for shock and vibration are maximum values and must not be applied continuously.

²⁾ The manufacturer's processing instructions must be observed.

8.15.5 Dimension drawing

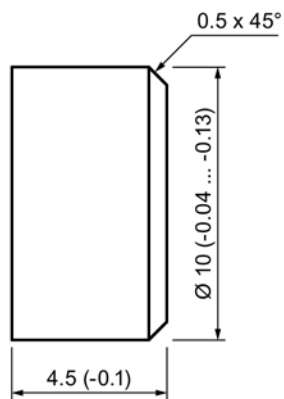



Figure 8-39 Dimension drawing of MDS D421

All dimensions in mm

8.16 MDS D422

8.16.1 Characteristics

MDS D422	Characteristics	
	Area of application	Identification of metallic workpiece holders, workpieces or containers
	Memory size	2000 bytes of FRAM user memory
	Write/read range	See section "Field data of ISO transponders (MDS D) (Page 52).
	Mounting on metal	Yes
	ISO standard	ISO 15693
	Degree of protection	IP68

8.16.2 Ordering data

Table 8- 39 Ordering data of MDS D422

	Article number
MDS D422 A screw-in aid is included in the scope of supply per packaging unit	6GT2600-4AF00

8.16.3 Mounting in metal

Flush-mounting

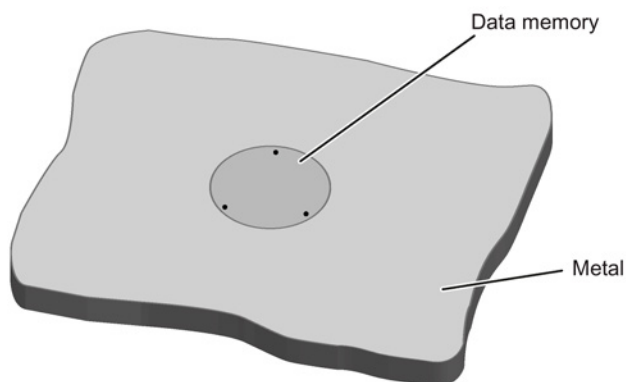

Figure 8-40 Mounting of MDS D422 in metal

Mounting information for screws

You can screw the transponder into a pre-drilled threaded hole using the screw-in aid.

Mounting information for adhesion

- Drill installation hole
- The adhesive surfaces must be dry, free from dust, oil, stripping agents and other impurities
- Apply adhesive according to the manufacturer's processing instructions
- Press in MDS D422 using your fingers; with antenna to the outside
- Remove residues of adhesive
- Allow to cure according to the manufacturer's instructions
- Flush-mounting of MDS D422 in metal with tools

8.16.4 Technical specifications

Table 8- 40 Technical specifications for the MDS D422

6GT2600-4AF00	
Product type designation	SIMATIC MDS D422
Memory	
Memory configuration	
• UID	• 8 bytes
• User memory	• 2000 bytes FRAM
• OPT memory	• 16 bytes FRAM
Read cycles (at < 40 °C)	> 10 ¹²
Write cycles (at < 40 °C)	> 10 ¹²
Data retention time (at < 40 °C)	> 10 years
Write/read distance (S _g)	Dependent on the reader used, see section "Field data of ISO transponders (MDS D) (Page 52)"
MTBF (Mean Time Between Failures)	285 years
Mechanical specifications	
Housing	
• Material	• Plastic PA 6.6 GF; brass nickel plated
• Color	• Black/silver
Recommended distance to metal	≥ 0 mm
Power supply	Inductive, without battery
Permitted ambient conditions	
Ambient temperature	
• During operation	• -25 to +85 °C
• During transportation and storage	• -40 to +100 °C
Degree of protection to EN 60529	• IP68 2 hours, 2 bar, +20 °C
Shock-resistant to EN 60721-3-7 class 7M3	50 g ¹⁾
Vibration-resistant to EN 60721-3-7, class 7M3	20 g ¹⁾
Torsion and bending load	Not permitted

6GT2600-4AF00

Design, dimensions and weight

Dimensions (Ø x H)	20 x 6 mm
Weight	13 g
Type of mounting	<ul style="list-style-type: none">• Glued• 1 x transponder thread M20 ≤ 1 Nm

1) The values for shock and vibration are maximum values and must not be applied continuously.

8.16.5 Dimension drawing

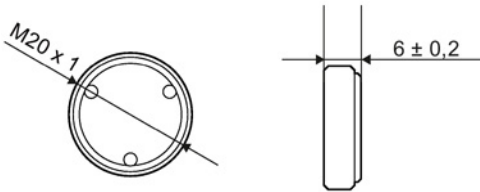

Dimensions in mm

Figure 8-41 Dimensional drawing of MDS D422

8.17 MDS D423

8.17.1 Characteristics

	MDS D423	
	Characteristics	
	Area of application	Identification of metallic workpiece holders, workpieces or containers, production automation
	Memory size	2000 bytes of FRAM user memory
	Write/read range	See section "Field data of ISO transponders (MDS D) (Page 52)"
	Mounting on metal	Yes, flush-mounted in metal
	ISO standard	ISO 15693
Degree of protection	IP68/IPx9K	

8.17.2 Ordering data

Table 8- 41 Ordering data of MDS D423

	Article number
MDS D423	6GT2600-4AA00

Table 8- 42 Ordering data of MDS D423 accessories

	Article number
Fixing hood RF330T / MDS D423	6GT2690-0EA00

8.17.3 Mounting on metal

Mounting on metal

Direct mounting of the MDS D423 on metal is possible.

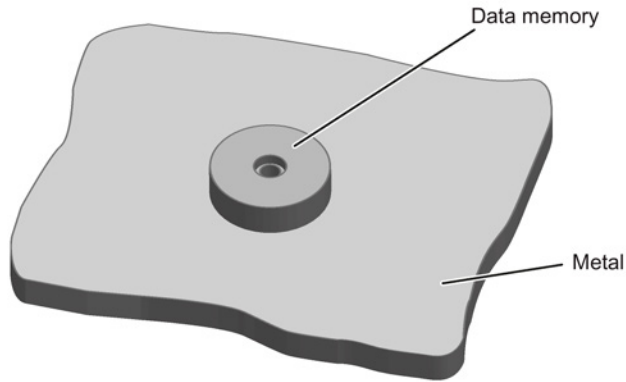

Figure 8-42 Mounting the MDS D423 on metal

Flush-mounted in metal

It is possible to mount the MDS D423 in metal.

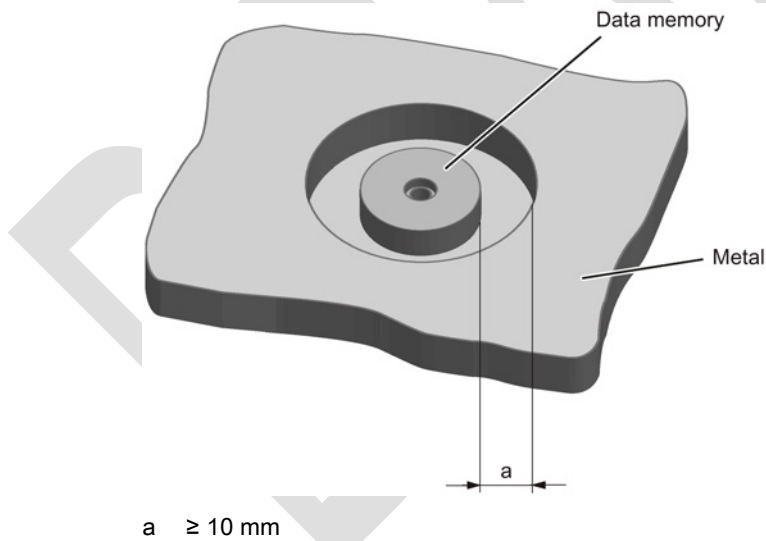

Figure 8-43 Flush-mounting of the MDS D423 in metal with 10 mm clearance

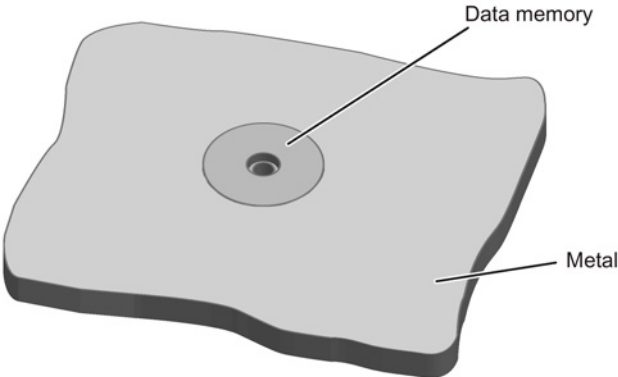

Figure 8-44 Flush-mounting of the MDS D423 in metal without clearance

Note

Reduction of the write/read range

Note that when the device is flush-mounted in metal without a surrounding clearance ≥ 10 mm, the write/read range is significantly reduced.

8.17.4 Technical specifications

Table 8- 43 Technical specifications of MDS D423

	6GT2600-4AA00
Product type designation	SIMATIC MDS D423
Memory	
Memory configuration	
• UID	• 8 bytes
• User memory	• 2000 bytes FRAM
• OPT memory	• 16 bytes FRAM
Read cycles (at < 40 °C)	> 10 ¹²
Write cycles (at < 40 °C)	> 10 ¹²
Data retention time (at < 40 °C)	> 10 years
Write/read distance (S _g)	Dependent on the reader used, see section "Field data of ISO transponders (MDS D) (Page 52)"
MTBF (Mean Time Between Failures)	228 years

6GT2600-4AA00

Mechanical specifications**Housing**

• Material	• Plastic PPS
• Color	• Black
Recommended distance to metal	≥ 0 mm
Power supply	Inductive, without battery

Permitted ambient conditions**Ambient temperature**

• During operation	• -25 to +85 °C
• During transportation and storage	• -40 to +100 °C

Degree of protection to EN 60529

- IP68
2 hours, 2 bar, +20 °C
- IPx9K
steam jet: 150 mm; 10 to 15 l/min; 100 bar; 75 °C

Shock-resistant to EN 60721-3-7 class 7M3 50 g ¹⁾Vibration-resistant to EN 60721-3-7, class 7M3 20 g ¹⁾**Pressure resistance**

- Low pressure resistant
vacuum dryer: up to 20 mbar
- High pressure resistant
(see degree of protection IPx9K)

Torsion and bending load

Not permitted

Design, dimensions and weight

Dimensions (Ø x H) 30 x 8 mm

Weight 15 g

Type of mounting 1 x M4 screw ²⁾
≤ 1 Nm

¹⁾ The values for shock and vibration are maximum values and must not be applied continuously.

²⁾) To prevent it loosening during operation, secure the screw with screw locking varnish.

8.17.5 Dimensional drawing

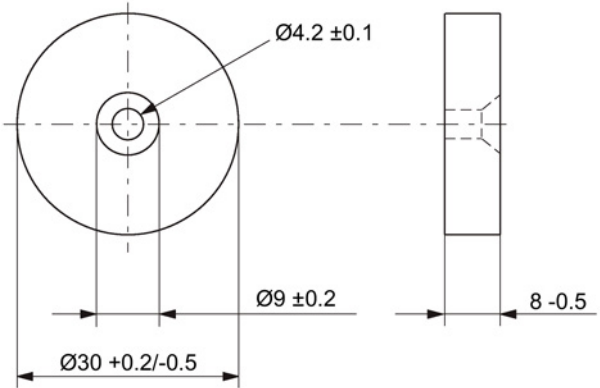

Dimensions in mm
Figure 8-45 Dimension drawing for MDS D423

DRAFT

8.18 MDS D424

8.18.1 Characteristics

MDS D424	Characteristics	
	Area of application	Production and distribution logistics as well as in assembly and production lines, can also be used in a harsh industrial environment without problem
	Memory size	2000 bytes of FRAM user memory
	Write/read range	See section "Field data of ISO transponders (MDS D) (Page 52)."
	Mounting on metal	Yes, with spacer
	ISO standard	ISO 15693
	Degree of protection	IP67; IPx9K

8.18.2 Ordering data

Table 8- 44 Ordering data of MDS D424

	Article number
MDS D424	6GT2600-4AC00

Table 8- 45 Ordering data of MDS D424 accessories

	Article number
Spacer	6GT2690-0AK00

8.18.3 Mounting on metal

Mounting on metal

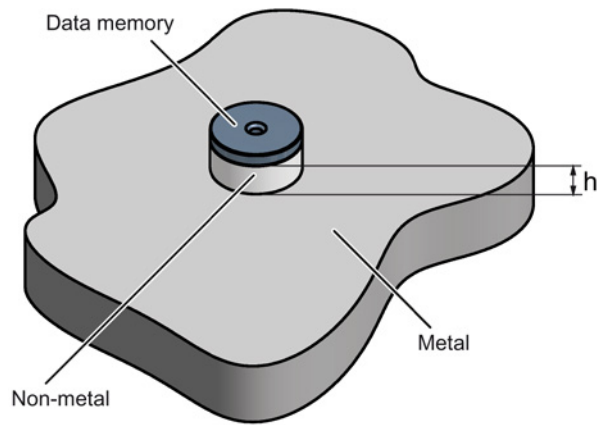

$$h \geq 15 \text{ mm}$$

Figure 8-46 Mounting the MDS D124/D324/D424/D524/E624 and RF320T on metal with spacer

Flush-mounting

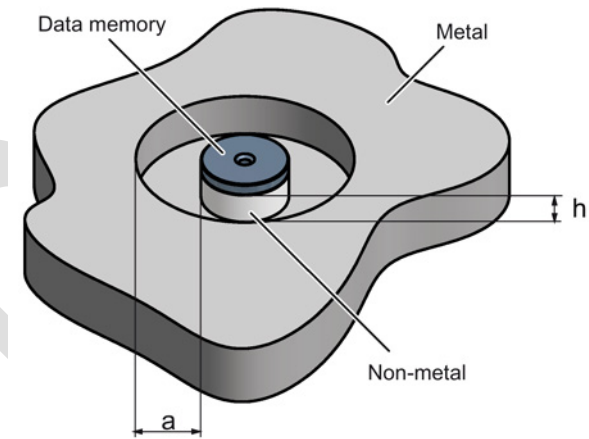

$$h \geq 15 \text{ mm}$$

$$a \geq 25 \text{ mm}$$

Figure 8-47 Flush-mounting of the MDS D124/D324/D424/D524/E624 and RF320T in metal with spacer

Note

Going below the distances

If the distances (a and h) are not observed, a reduction of the field data results. It is possible to mount the MDS with metal screws (M3 countersunk head screws). This has no tangible impact on the range.

8.18.4 Technical specifications

Table 8- 46 Technical specifications for the MDS D424

6GT2600-4AC00	
Product type designation	SIMATIC MDS D424
Memory	
Memory configuration	
• UID	• 8 bytes
• User memory	• 2000 bytes FRAM
• OPT memory	• 16 bytes FRAM
Read cycles (at < 40 °C)	> 10 ¹²
Write cycles (at < 40 °C)	> 10 ¹²
Data retention time (at < 40 °C)	> 10 years
Write/read distance (S ₉)	Dependent on the reader used, see section "Field data of ISO transponders (MDS D) (Page 52)"
MTBF (Mean Time Between Failures)	228 years
Mechanical specifications	
Housing	
• Material	• Epoxy resin
• Color	• Black
Recommended distance to metal	≥ 15 mm
Power supply	Inductive, without battery

6GT2600-4AC00

Permitted ambient conditions

Ambient temperature

- | | |
|-------------------------------------|------------------|
| • During operation | • -25 to +85 °C |
| • During transportation and storage | • -40 to +100 °C |

Degree of protection to EN 60529

- IP67
- IPx9K

Shock-resistant to EN 60721-3-7 class 7M3 100 g ¹⁾

Vibration-resistant to EN 60721-3-7, class 7M3 20 g ¹⁾

Torsion and bending load Not permitted

Design, dimensions and weight

Dimensions (Ø x H) 27 x 4 mm

Weight 5 g

- Type of mounting
- Glued
 - 1 x M3 screw ²⁾ ≤ 1 Nm

¹⁾ The values for shock and vibration are maximum values and must not be applied continuously.

²⁾) To prevent it loosening during operation, secure the screw with screw locking varnish.

8.18.5 Dimension drawing

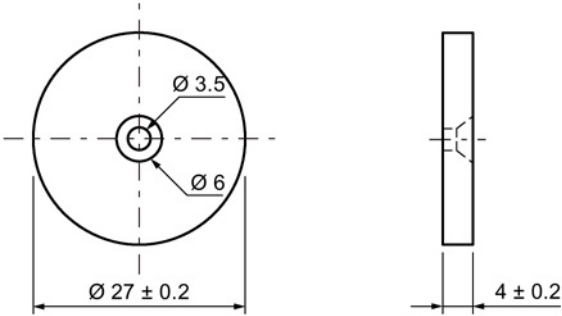



Figure 8-48 Dimension drawing of MDS D424

All dimensions in mm

8.19 MDS D425

8.19.1 Characteristics

MDS D425	Characteristics	
	Area of application	Compact and rugged ISO transponder; suitable for screw mounting Use in assembly and production lines in the powertrain sector; ideal for mounting on motors, gearboxes, and work-piece holders Rugged packaging of the MDS D425; can therefore also be used under extreme environmental conditions without problem
	Memory size	2000 bytes of FRAM user memory
	Write/read range	See section "Field data of ISO transponders (MDS D) (Page 52)".
	Mounting on metal	Yes
	ISO standard	ISO 15693
	Degree of protection	IP68/IPx9K

8.19.2 Ordering data

Table 8- 47 Ordering data of MDS D425

	Article number
MDS D425	6GT2600-4AG00

8.19.3 Application example

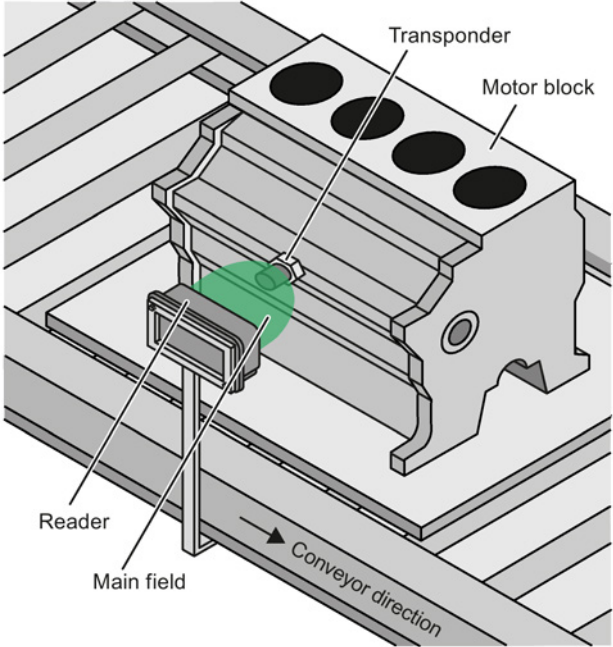

Figure 8-49 Application example

8.19.4 Technical specifications

Table 8- 48 Technical specifications for the MDS D425

	6GT2600-4AG00
Product type designation	SIMATIC MDS D425
Memory	
Memory configuration	
• UID	• 8 bytes
• User memory	• 2000 bytes FRAM
• OPT memory	• 16 bytes FRAM
Read cycles (at < 40 °C)	> 10 ¹²
Write cycles (at < 40 °C)	> 10 ¹²
Data retention time (at < 40 °C)	> 10 years
Write/read distance (S _g)	Dependent on the reader used, see section "Field data of ISO transponders (MDS D) (Page 52)"
MTBF (Mean Time Between Failures)	228 years

6GT2600-4AG00

Mechanical specifications

Housing

• Material	• Plastic PA 6.6 GF
• Color	• Black
Recommended distance to metal	≥ 0 mm
Power supply	Inductive, without battery

Permitted ambient conditions

Ambient temperature

• During operation	• -25 to +85 °C
• During transportation and storage	• -40 to +125 °C

Degree of protection to EN 60529

- IP68
2 hours, 2 bar, +20 °C
- IPx9K
steam jet: 150 mm; 10 to 15 l/min; 100 bar; 75 °C

Shock-resistant to IEC 68-2-27	50 g ¹⁾
--------------------------------	--------------------

Vibration-resistant to IEC 68-2-6	20 g ¹⁾
-----------------------------------	--------------------

Torsion and bending load	Not permitted
--------------------------	---------------

Design, dimensions and weight

Dimensions (Ø x H)	24 x 10 mm (without set screw)
--------------------	--------------------------------

Weight	35 g
--------	------

Type of mounting	1x transponder set screw M6 SW 22; ≤ 6 Nm
------------------	--

¹⁾ The values for shock and vibration are maximum values and must not be applied continuously.

8.19.5 Dimension drawing

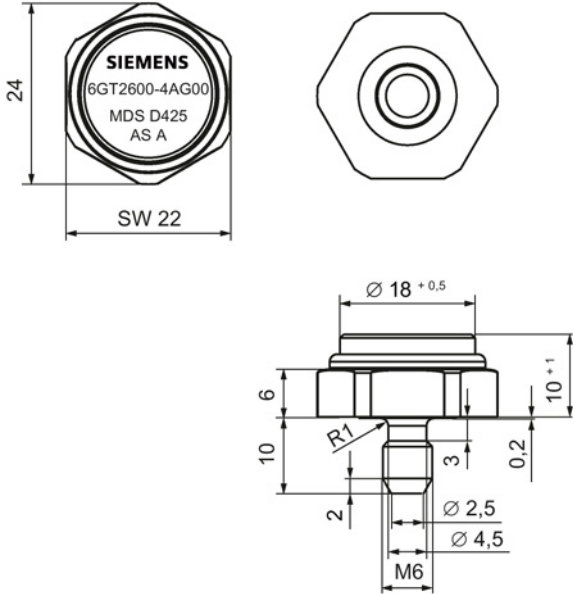

Dimensions in mm
Figure 8-50 Dimension drawing of MDS D425

8.20 MDS D426

8.20.1 Characteristics

MDS D426	Characteristics	
 <p>SIEMENS 6GT2600-4AH00 MDS D426 MOBY D AS: A</p>	Area of application	Compact and rugged ISO transponder; suitable for identification of transport units in production-related logistics; can also be deployed in harsh conditions
	Memory size	2000 bytes of FRAM user memory
	Write/read range	See section Field data of ISO transponders (MDS D) (Page 52)
	Mounting on metal	Yes, with spacer
	ISO standard	ISO 15693
	Degree of protection	IP68

8.20.2 Ordering data

Table 8- 49 Ordering data of MDS D426

	Article number
MDS D426	6GT2600-4AH00

Table 8- 50 Ordering data of MDS D426 accessories

	Article number
Spacer	6GT2690-0AL00

8.20.3 Mounting on metal

Mounting on metal

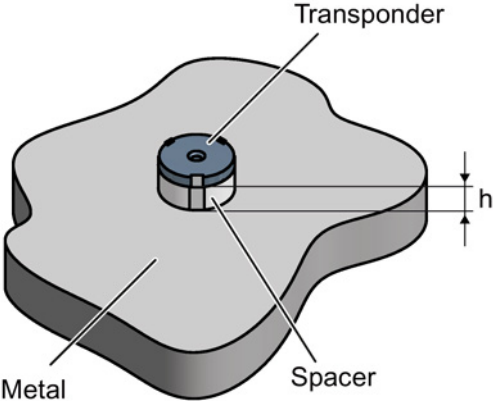

$h \geq 25 \text{ mm}$

Figure 8-51 Mounting the MDS D126 / D426 / D526 on metal with spacer

Flush-mounted in metal

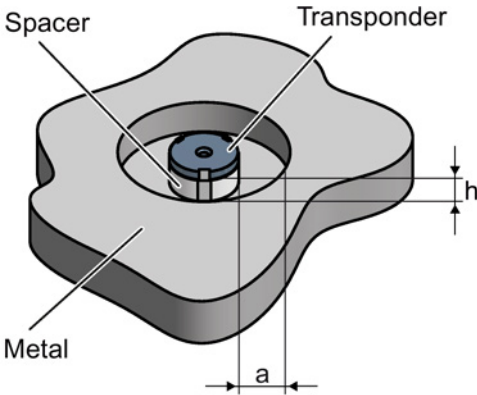

$h \geq 25 \text{ mm}$
 $a \geq 50 \text{ mm}$

Figure 8-52 Flush installation of the MDS D126 / D426 / D526 in metal with spacer

8.20.4 Technical specifications

Table 8- 51 Technical specifications for the MDS D426

6GT2600-4AH00	
Product type designation	SIMATIC MDS D426
Memory	
Memory configuration	
• UID	• 8 bytes
• User memory	• 2000 bytes FRAM
• OPT memory	• 16 bytes FRAM
Read cycles (at < 40 °C)	> 10 ¹²
Write cycles (at < 40 °C)	> 10 ¹²
Data retention time (at < 40 °C)	> 10 years
Write/read distance (S ₉)	Dependent on the reader used, see section "Field data of ISO transponders (MDS D) (Page 52)"
MTBF (Mean Time Between Failures)	228 years
Mechanical specifications	
Housing	
• Material	• Plastic PA 6.6 GF
• Color	• Black
Recommended distance to metal	≥ 25 mm
Power supply	Inductive, without battery
Permitted ambient conditions	
Ambient temperature	
• During operation	• -25 to +85 °C
• During transportation and storage	• -40 to +100 °C
Degree of protection to EN 60529	IP68 2 hours, 2 bar, +20 °C
Shock-resistant to IEC 68-2-27	50 g ¹⁾
Vibration-resistant to IEC 68-2-6	20 g ¹⁾
Torsion and bending load	Not permitted

6GT2600-4AH00

Design, dimensions and weight

Dimensions (Ø x H)	50 x 3.6 mm
Weight	13 g
Type of mounting	1 x M4 screw ²⁾ ≤ 1 Nm

1) The values for shock and vibration are maximum values and must not be applied continuously.
2)) To prevent it loosening during operation, secure the screw with screw locking varnish.

8.20.5 Dimension drawing

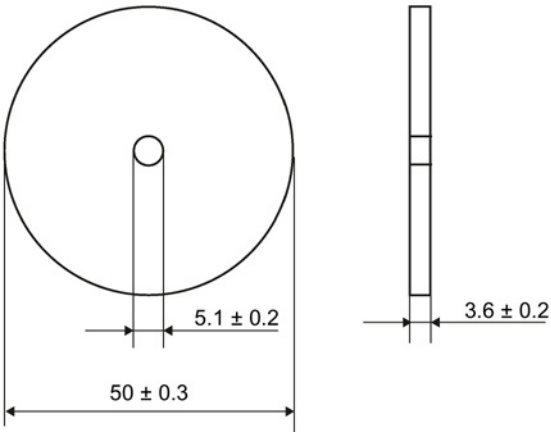

Dimensions in mm

Figure 8-53 Dimension drawing of MDS D426

8.21 MDS D428

8.21.1 Characteristics

<p>MDS D428</p> 	<p>Characteristics</p>	
<p>Area of application</p>	<p>Compact and rugged ISO transponder; suitable for screw mounting. Use in assembly and production lines in the powertrain sector. The rugged housing of the MDS D428 means that it can also be used in extreme environmental conditions without problems.</p>	
<p>Memory size</p>	<p>2000 bytes of FRAM user memory</p>	
<p>Write/read range</p>	<p>See section "Field data of ISO transponders (MDS D) (Page 52)"</p>	
<p>Mounting on metal</p>	<p>Yes</p>	
<p>ISO standard</p>	<p>ISO 15693</p>	
<p>Degree of protection</p>	<p>IP68/IPx9K</p>	

8.21.2 Ordering data

Table 8- 52 Ordering data of MDS D428

	Article number
MDS D428	6GT2600-4AK00-0AX0

8.21.3 Application example

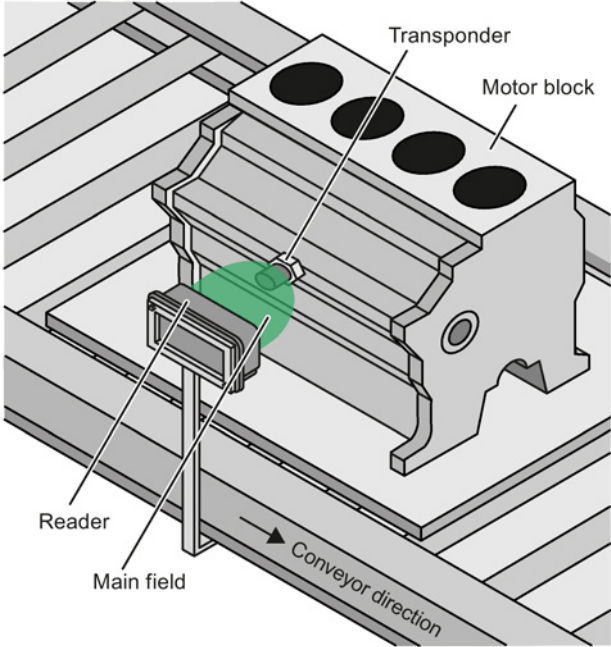

Figure 8-54 Application example

8.21.4 Technical specifications

Table 8- 53 Technical specifications for the MDS D428

	6GT2600-4AK00
Product type designation	SIMATIC MDS D428
Memory	
Memory configuration	
• UID	• 8 bytes
• User memory	• 2000 bytes FRAM
• OPT memory	• 16 bytes FRAM
Read cycles (at < 40 °C)	> 10 ¹²
Write cycles (at < 40 °C)	> 10 ¹²
Data retention time (at < 40 °C)	> 10 years
Write/read distance (S _g)	Dependent on the reader used, see section "Field data of ISO transponders (MDS D) (Page 52)"
MTBF (Mean Time Between Failures)	228 years

6GT2600-4AK00

Mechanical specifications**Housing**

• Material	• Plastic PA 6.6 GF
• Color	• Black
Recommended distance to metal	≥ 0 mm
Power supply	Inductive, without battery

Permitted ambient conditions**Ambient temperature**

• During operation	• -25 to +85 °C
• During transportation and storage	• -40 to +125 °C

Degree of protection to EN 60529

- IP68
2 hours, 2 bar, +20 °C
- IPx9K
steam jet: 150 mm; 10 to 15 l/min; 100 bar; 75 °C

Shock-resistant to IEC 68-2-27	50 g ¹⁾
--------------------------------	--------------------

Vibration-resistant to IEC 68-2-6	20 g ¹⁾
-----------------------------------	--------------------

Torsion and bending load	Not permitted
--------------------------	---------------

Design, dimensions and weight

Dimensions (Ø x H)	24 x 20 mm (without set screw)
--------------------	--------------------------------

Weight	35 g
--------	------

Type of mounting	1x transponder set screw M8 SW 22; ≤ 8 Nm
------------------	--

¹⁾ The values for shock and vibration are maximum values and must not be applied continuously.

8.21.5 Dimension drawing

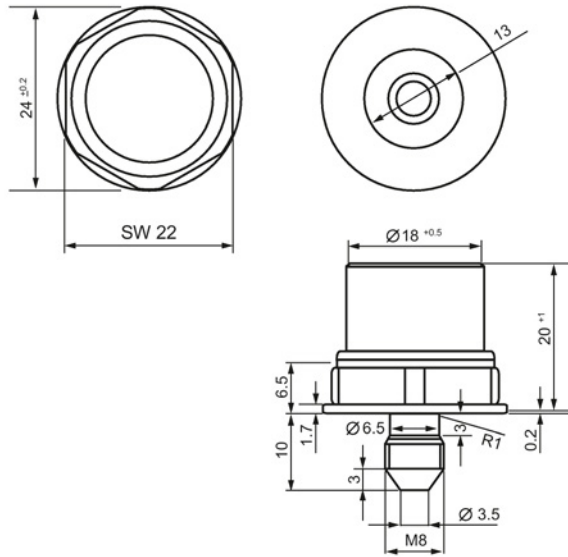

Dimensions in mm

Figure 8-55 Dimension drawing of MDS D428

8.22 MDS D460

8.22.1 Characteristics

MDS D460	Characteristics	
 <p>SIEMENS 6GT2600-4AB00 MDS D460 MOBY D</p>	Area of application	Identification in small assembly lines; can also be used in a harsh industrial environment
	Memory size	2000 bytes of FRAM user memory
	Write/read range	See section "Field data of ISO transponders (MDS D) (Page 52).
	Mounting on metal	Yes, with spacer
	ISO standard	ISO 15693
	Degree of protection	IP67/IPx9K

8.22.2 Ordering data

Table 8- 54 Ordering data of MDS D460

	Article number
MDS D460	6GT2600-4AB00

Table 8- 55 Ordering data of MDS D460 accessories

	Article number
Spacer	6GT2690-0AG00

8.22.3 Mounting on metal

Mounting option on metal with spacer

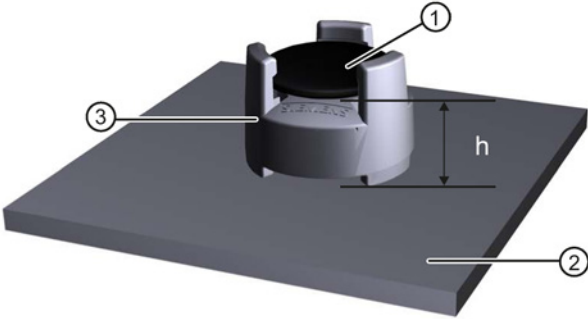

- ① Transponder
- ② Metal
- ③ Spacer
- h ≥ 10 mm

Figure 8-56 Mounting the MDS D460 on metal with spacer

Note

If the minimum guide values (h) are not observed, a reduction of the field data results. In critical applications, it is recommended that a test is performed.

Flush-mounting

Flush-mounting of the MDS D460 in metal is not permitted!

8.22.4 Technical specifications

Table 8- 56 Technical specifications for MDS D460

6GT2600-4AB00	
Product type designation	SIMATIC MDS D460
Memory	
Memory configuration	
• UID	• 8 bytes
• User memory	• 2000 bytes FRAM
• OPT memory	• 16 bytes FRAM

6GT2600-4AB00	
Read cycles (at < 40 °C)	> 10 ¹²
Write cycles (at < 40 °C)	> 10 ¹²
Data retention time (at < 40 °C)	> 10 years
Write/read distance (S _g)	Dependent on the reader used, see section "Field data of ISO transponders (MDS D) (Page 52)"
MTBF (Mean Time Between Failures)	228 years
Mechanical specifications	
Housing	
• Material	• Epoxy resin
• Color	• Black
Recommended distance to metal	≥ 10 mm
Power supply	Inductive, without battery
Permitted ambient conditions	
Ambient temperature	
• During operation	• -25 to +85 °C
• During transportation and storage	• -40 to +100 °C
Degree of protection to EN 60529	• IP67 • IPx9K steam jet: 150 mm; 10 to 15 l/min; 100 bar; 75 °C
Shock-resistant to IEC 68-2-27	50 g ¹⁾
Vibration-resistant to IEC 68-2-6	20 g ¹⁾
Torsion and bending load	Not permitted
Design, dimensions and weight	
Dimensions (Ø x H)	16 x 3 mm
Weight	3 g
Type of mounting	• Glued • With spacer

¹⁾ The values for shock and vibration are maximum values and must not be applied continuously.

8.22.5 Dimension drawings

Dimensional drawing of MDS D460

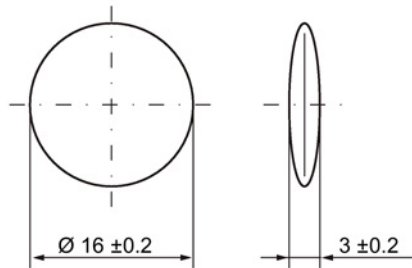

Dimensions in mm

Figure 8-57 Dimensional drawing of MDS D460

Dimensional drawing of spacer

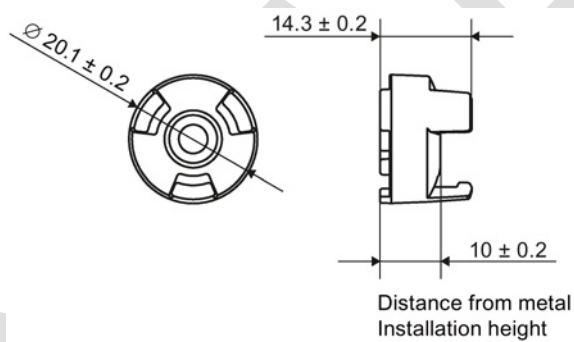

Dimensions in mm

Figure 8-58 Dimensional drawing of spacer

8.23 MDS D521

8.23.1 Characteristics

MDS D521	Characteristics	
	Area of application	<p>The MDS D521 is designed for tool coding according to DIN 69873.</p> <p>It can be used wherever small data carriers and exact positioning are required, e.g. tool identification, workpiece holders.</p> <p>The rugged housing of the MDS D521 means that it can also be used in a harsh industrial environment without problems.</p>
	Memory size	8192 bytes of FRAM user memory
	Write/read range	See section "Field data of ISO transponders (MDS D) (Page 52)"
	Mounting on metal	Yes, flush-mounted in metal
	ISO standard	ISO 15693
	Degree of protection	IP67/IPx9K

8.23.2 Ordering data

Table 8- 57 Ordering data for MDS D521

	Article number
MDS D521	6GT2600-5AE00

8.23.3 Mounting on metal

Mounting on metal

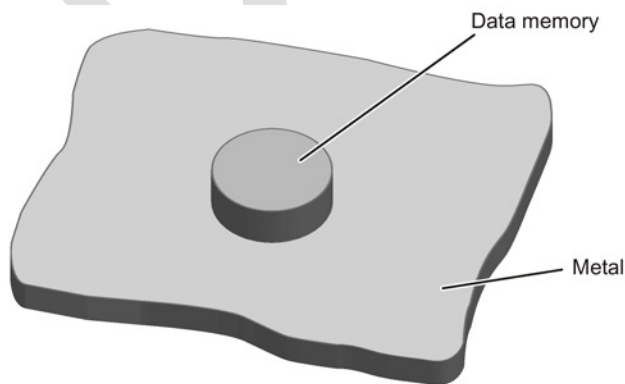

Figure 8-59 Mounting of MDS D421/D521/E623 on metal

Flush-mounting

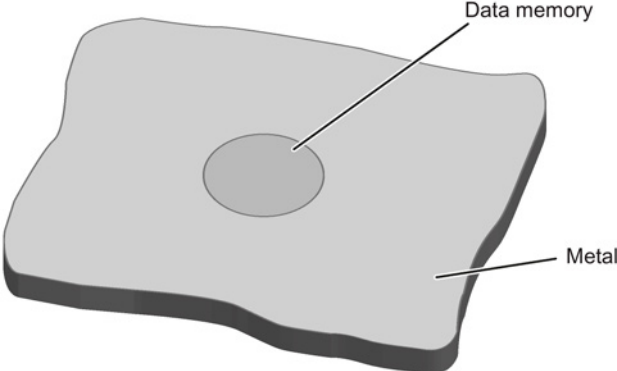

Figure 8-60 Mounting of MDS D421/D521/E623 in metal

Flush-mounting of the MDS in metal with tools

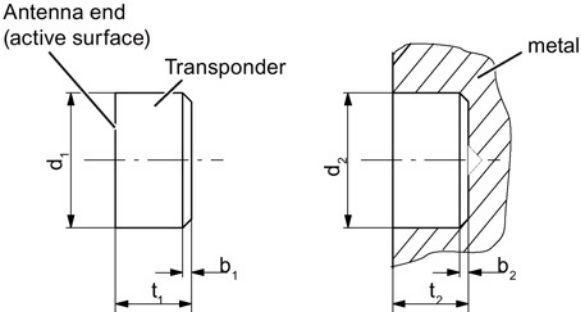

Figure 8-61 Flush-mounting of MDS D421/D521/E623 in metal with tools

b ₁	0.5 x 45°	b ₂	0.3 x 45° or R0.3
d ₁	10 (-0.04... -0.13)	d ₂	10 (+0.09... 0)
t ₁	4.5 (-0 ... -0.1)	t ₂	4.6 (+0.2 ... 0)

All dimensions in mm

Note
Installation instruction

The MDS should not protrude out of the locating hole; it must be flush with the outside contour.

The mounting instructions of the MDS and the conditions associated with the application (e.g. peripheral speed, temperature, and use of coolant) must be observed during the installation.

Mounting information for adhesion

- Drill installation hole
- The adhesive surfaces must be dry, free from dust, oil, stripping agents and other impurities
- Apply adhesive according to the manufacturer's processing instructions
- Press in transponder using your fingers; with antenna side to the outside (see figure above)
- Remove residues of adhesive
- Allow to cure according to the manufacturer's instructions
- Flush-mounting of the transponder in metal with tools

Installation examples

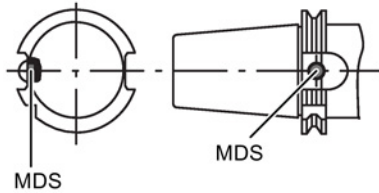

Figure 8-62 Installation example of MDS D421/D521/E623 in a steep cone

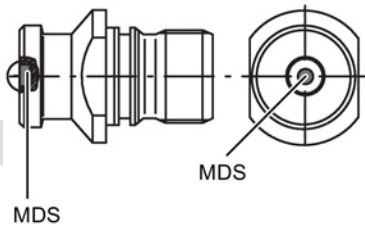

Figure 8-63 Installation example of MDS D421/D521/E623 in a stud bolt

8.23.4 Technical specifications

Table 8- 58 Technical specifications for MDS D521

6GT2600-5AE00	
Product type designation	SIMATIC MDS D521
Memory	
Memory configuration	
• UID	• 8 bytes
• User memory	• 8192 bytes FRAM
Read cycles (at < 40 °C)	> 10 ¹²
Write cycles (at < 40 °C)	> 10 ¹²
Data retention time (at < 40 °C)	> 10 years
Write/read distance (S _g)	Dependent on the reader used, see section "Field data of ISO transponders (MDS D) (Page 52)"
MTBF (Mean Time Between Failures)	228 years
Mechanical specifications	
Housing	
• Material	• Epoxy resin
• Color	• Black
Recommended distance to metal	> 25 mm
Power supply	Inductive, without battery
Permitted ambient conditions	
Ambient temperature	
• During operation	• -25 to +85 °C
• During transportation and storage	• -40 to +100 °C
Degree of protection to EN 60529	• IP67 • IPx9K steam jet: 150 mm; 10 to 15 l/min; 100 bar; 75 °C
Shock-resistant to EN 60721-3-7 class 7M3	100 g ¹⁾
Vibration-resistant to EN 60721-3-7, class 7M3	20 g ¹⁾
Torsion and bending load	Not permitted

6GT2600-5AE00

Design, dimensions and weight

Dimensions (Ø x H)	10 x 4.5 mm
Weight	4 g
Type of mounting	Glued ²⁾

- 1) The values for shock and vibration are maximum values and must not be applied continuously.
- 2) The manufacturer's processing instructions must be observed.

8.23.5 Dimension drawing

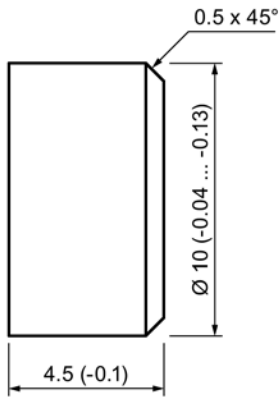



Figure 8-64 Dimension drawing of MDS D521

All dimensions in mm

8.24 MDS D522

8.24.1 Characteristics

MDS D522	Characteristics	
	Area of application	Identification of metallic workpiece holders, workpieces or containers
	Memory size	8192 bytes of FRAM user memory
	Write/read range	See "Field data of ISO transponders (MDS D) (Page 52)."
	Mounting in metal	Yes
	ISO standard	ISO 15693
	Degree of protection	IP68

8.24.2 Ordering data

Table 8- 59 Ordering data for MDS D522

	Article number
MDS D522 Units in a package: 10 units A mounting aid is included in the scope of supply per packaging unit.	6GT2600-5AF00

8.24.3 Mounting in metal

Flush-mounting

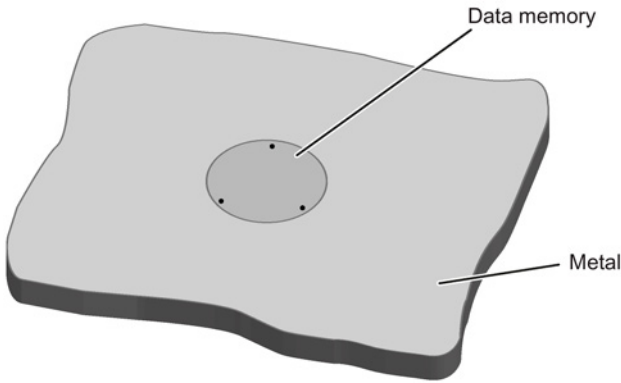

Figure 8-65 Mounting of MDS D522 in metal

Mounting information for screws

You can screw the transponder into a pre-drilled threaded hole using the screw-in aid.

Mounting information for adhesion

- Drill installation hole
- The adhesive surfaces must be dry, free from dust, oil, stripping agents and other impurities
- Apply adhesive according to the manufacturer's processing instructions
- Press in MDS D522 using your fingers; with antenna to the outside
- Remove residues of adhesive
- Allow to cure according to the manufacturer's instructions
- Flush-mounting of MDS D522 in metal with tools

8.24.4 Technical specifications

Table 8- 60 Technical specifications for MDS D522

6GT2600-5AF00	
Product type designation	SIMATIC MDS D522
Memory	
Memory configuration	
• UID	• 8 bytes
• User memory	• 8192 bytes FRAM
Read cycles (at < 40 °C)	> 10 ¹²
Write cycles (at < 40 °C)	> 10 ¹²
Data retention time (at < 40 °C)	> 10 years
Write/read distance (S _g)	Dependent on the reader used, see section "Field data of ISO transponders (MDS D) (Page 52)"
MTBF (Mean Time Between Failures)	285 years
Mechanical specifications	
Housing	
• Material	• Plastic PA 6.6 GF; brass nickel plated
• Color	• Black/silver
Recommended distance to metal	≥ 0 mm
Power supply	Inductive, without battery

6GT2600-5AF00

Permitted ambient conditions

Ambient temperature

- | | |
|-------------------------------------|------------------|
| • During operation | • -25 to +85 °C |
| • During transportation and storage | • -40 to +100 °C |

Degree of protection to EN 60529

- IP68
2 hours, 2 bar, +20 °C

Shock-resistant to EN 60721-3-7 class 7M3

50 g ¹⁾

Vibration-resistant to EN 60721-3-7, class 7M3

20 g ¹⁾

Torsion and bending load

Not permitted

Design, dimensions and weight

Dimensions (Ø x H)

20 x 6 mm

Weight

13 g

Type of mounting

- Glued
- 1 x transponder thread M20
≤ 1 Nm

¹⁾ The values for shock and vibration are maximum values and must not be applied continuously.

8.24.5

Dimension drawing

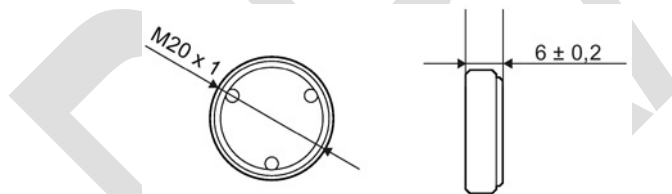



Figure 8-66 Dimensional drawing of MDS D522

All dimensions in mm

8.25 MDS D522 special variant

8.25.1 Characteristics

MDS D522 special version	Characteristics	
	Area of application	Identification of metallic workpiece holders or workpieces
	Memory size	8192 bytes of FRAM user memory
	Write/read range	See "Field data of ISO transponders (MDS D) (Page 52)."
	Mounting in metal	Yes
	ISO standard	ISO 15693
	Degree of protection	IP68

8.25.2 Ordering data

Table 8- 61 MDS D522 special version

	Article number
MDS D522 special version Units in a package: 10 units A mounting aid is included in the scope of supply per packaging unit.	6GT2600-5AF00-0AX0

8.25.3 Mounting in metal

Flush-mounting

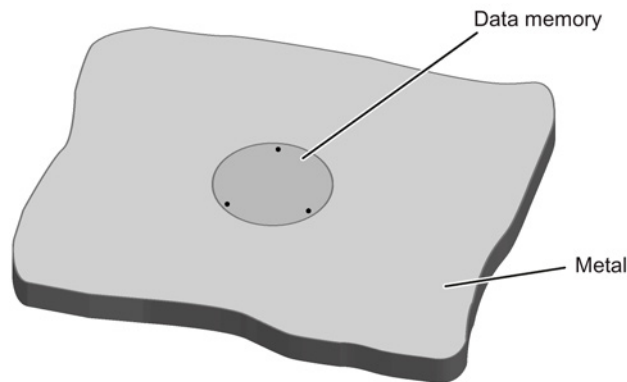

Figure 8-67 Flush installation of the MDS D522 special version in metal without clearance

8.25.4 Installation instructions

The transponder MDS D522 special version is designed to be mounted once.

Note the following instructions when mounting the MDS D522 in a workpiece to avoid damaging the transponder:

- Prepare the workpiece according to the following drawing.
- Using the accompanying mounting aid, press the transponder with uniform and evenly distributed pressure into the drilled hole until the transponder locks in place. Make sure that the transponder does not become tilted.

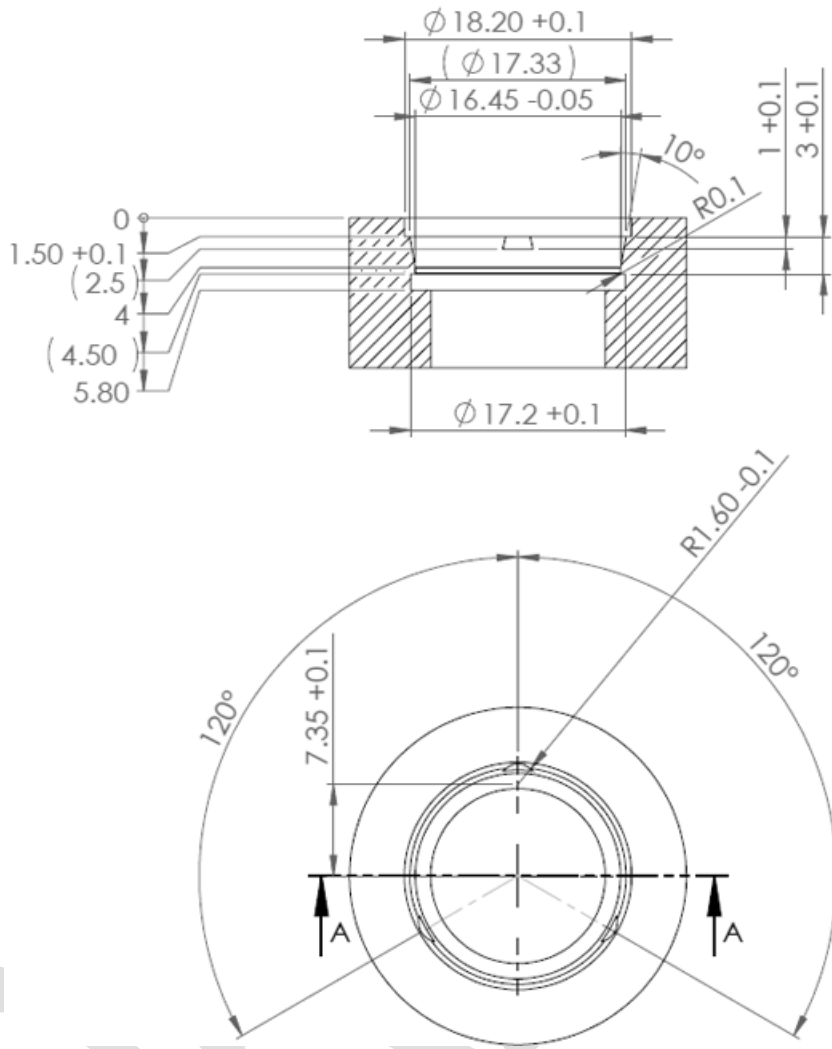

Figure 8-68 Dimension drawing: Workpiece drill hole for mounting the MDS D522 special version

8.25.5 Technical specifications

Table 8- 62 Technical data of MDS D522 special version

6GT2600-5AF00-0AX0	
Product type designation	SIMATIC MDS D522 special version
Memory	
Memory configuration	
• UID	• 8 bytes
• User memory	• 8192 bytes FRAM
Read cycles (at < 40 °C)	> 10 ¹²
Write cycles (at < 40 °C)	> 10 ¹²
Data retention time (at < 40 °C)	> 10 years
Write/read distance (S _g)	Dependent on the reader used, see section "Field data of ISO transponders (MDS D) (Page 52)"
MTBF (Mean Time Between Failures)	228 years
Mechanical specifications	
Housing	
• Material	• Plastic PA 6.6 GF
• Color	• Black
Recommended distance to metal	≥ 0 mm
Power supply	Inductive, without battery
Permitted ambient conditions	
Ambient temperature	
• During operation	• -25 to +85 °C
• During transportation and storage	• -40 to +100 °C
Degree of protection to EN 60529	IP68 2 hours, 2 bar, +20 °C
Shock-resistant to EN 60721-3-7 class 7M3	50 g ¹⁾
Vibration-resistant to EN 60721-3-7, class 7M3	20 g ¹⁾
Torsion and bending load	Not permitted
Design, dimensions and weight	
Dimensions (Ø x H)	18 (+0.1) × 5.2 mm
Weight	Approx. 1.2 g
Type of mounting	Clipping in once (with accompanying tool)

¹⁾ The values for shock and vibration are maximum values and must not be applied continuously.

8.25.6 Dimensional drawing

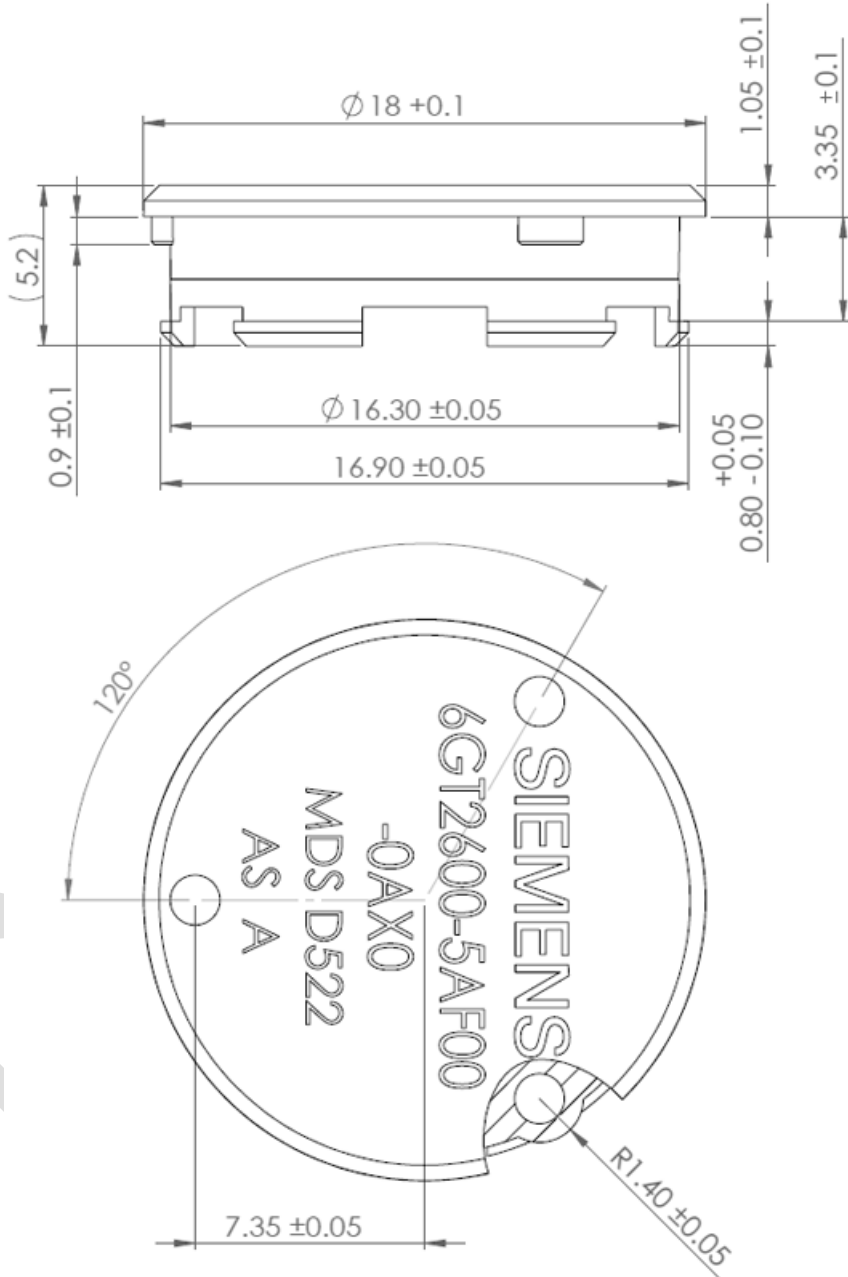



Figure 8-69 Dimension drawing MDS D522 special version

All dimensions in mm

8.26 MDS D524

8.26.1 Characteristics

MDS D524	Characteristics	
	Area of application	Production and distribution logistics as well as in assembly and production lines, can also be used in a harsh industrial environment without problem
	Memory size	8192 bytes of FRAM user memory
	Write/read range	See section "Field data of ISO transponders (MDS D) (Page 52)."
	Mounting on metal	Yes, with spacer
	ISO standard	ISO 15693
	Degree of protection	IP67; IPx9K

8.26.2 Ordering data

Table 8- 63 Ordering data for MDS D524

	Article number
MDS D524	6GT2600-5AC00

Table 8- 64 Ordering data of MDS D524 accessories

	Article number
Spacer	6GT2690-0AK00

8.26.3 Mounting on metal

Mounting on metal

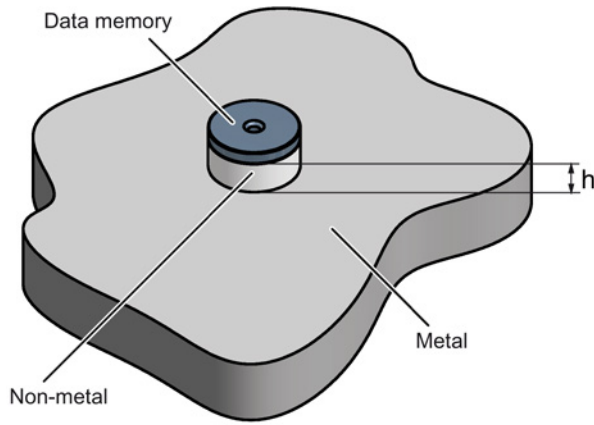

$$h \geq 15 \text{ mm}$$

Figure 8-70 Mounting the MDS D124/D324/D424/D524/E624 and RF320T on metal with spacer

Flush-mounting

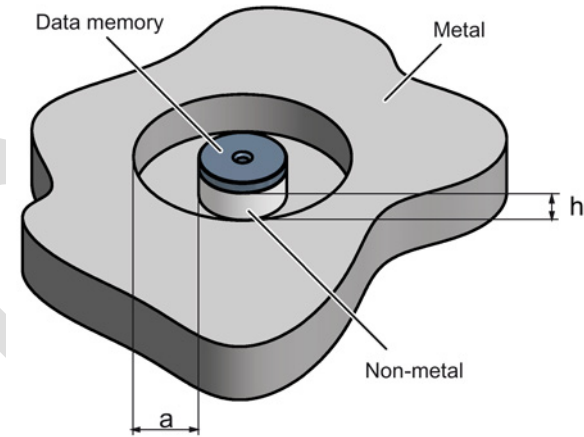

$$h \geq 15 \text{ mm}$$

$$a \geq 25 \text{ mm}$$

Figure 8-71 Flush-mounting of the MDS D124/D324/D424/D524/E624 and RF320T in metal with spacer

Note

Going below the distances

If the distances (a and h) are not observed, a reduction of the field data results. It is possible to mount the MDS with metal screws (M3 countersunk head screws). This has no tangible impact on the range.

8.26.4 Technical specifications

Table 8- 65 Technical specifications for MDS D524

6GT2600-5AC00	
Product type designation	SIMATIC MDS D524
Memory	
Memory configuration	
• UID	• 8 bytes
• User memory	• 8192 bytes FRAM
Read cycles (at < 40 °C)	> 10 ¹²
Write cycles (at < 40 °C)	> 10 ¹²
Data retention time (at < 40 °C)	> 10 years
Write/read distance (S _g)	Dependent on the reader used, see section "Field data of ISO transponders (MDS D) (Page 52)"
MTBF (Mean Time Between Failures)	228 years
Mechanical specifications	
Housing	
• Material	• Epoxy resin
• Color	• Black
Recommended distance to metal	≥ 25 mm
Power supply	Inductive, without battery
Permitted ambient conditions	
Ambient temperature	
• During operation	• -25 to +85 °C
• During transportation and storage	• -40 to +100 °C

6GT2600-5AC00	
Degree of protection to EN 60529	<ul style="list-style-type: none"> • IP67 • IPx9K
Shock-resistant to EN 60721-3-7 class 7M3	100 g ¹⁾
Vibration-resistant to EN 60721-3-7, class 7M3	20 g ¹⁾
Torsion and bending load	Not permitted
Design, dimensions and weight	
Dimensions (Ø x H)	27 x 4 mm
Weight	5 g
Type of mounting	<ul style="list-style-type: none"> • Glued • 1 x M3 screw ²⁾ ≤ 1 Nm

1) The values for shock and vibration are maximum values and must not be applied continuously.

2)) To prevent it loosening during operation, secure the screw with screw locking varnish.

8.26.5 Dimension drawing

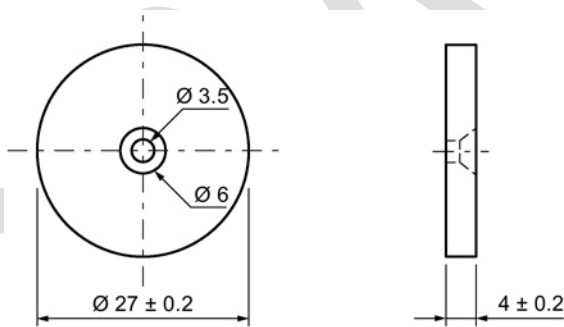



Figure 8-72 Dimensional drawing of MDS D524

All dimensions in mm

8.27 MDS D525

8.27.1 Characteristics

MDS D525	Characteristics	
	Area of application	Compact and rugged ISO transponder; suitable for screw mounting Use in assembly and production lines in the powertrain sector; ideal for mounting on motors, gearboxes, and work-piece holders Rugged packaging of the MDS D525; can therefore also be used under extreme environmental conditions without problems
	Memory size	8192 bytes of FRAM user memory
	Write/read range	See section "Field data of ISO transponders (MDS D) (Page 52)".
	Mounting on metal	Yes
	ISO standard	ISO 15693
	Degree of protection	IP68/IPx9K

8.27.2 Ordering data

Table 8- 66 Ordering data for MDS D525

	Article number
MDS D525	6GT2600-5AG00

8.27.3 Application example

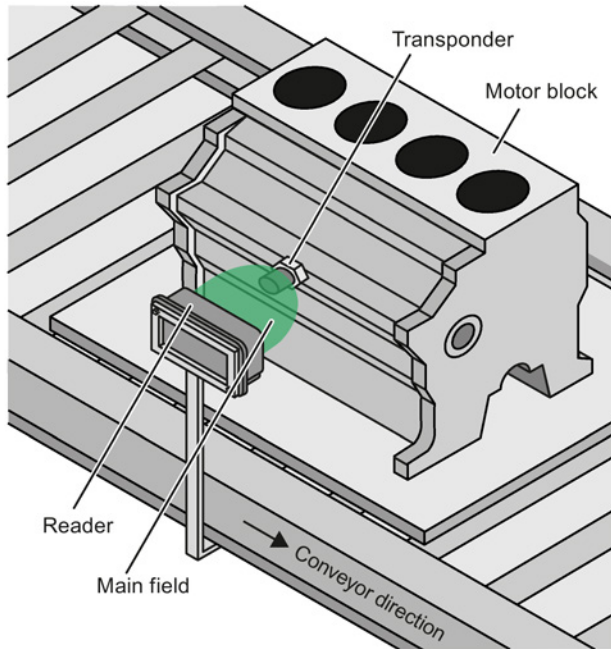

Figure 8-73 Application example

8.27.4 Technical specifications

Table 8- 67 Technical specifications for MDS D525

	6GT2600-5AG00
Product type designation	SIMATIC MDS D525
Memory	
Memory configuration	
• UID	• 8 bytes
• User memory	• 8192 bytes FRAM
• OPT memory	• 16 bytes FRAM
Read cycles (at < 40 °C)	> 10 ¹²
Write cycles (at < 40 °C)	> 10 ¹²
Data retention time (at < 40 °C)	> 10 years
Write/read distance (S ₉)	Dependent on the reader used, see section "Field data of ISO transponders (MDS D) (Page 52)"
MTBF (Mean Time Between Failures)	228 years

6GT2600-5AG00

Mechanical specifications

Housing

• Material	• Plastic PA 6.6 GF
• Color	• Black
Recommended distance to metal	> 0 mm
Power supply	Inductive, without battery

Permitted ambient conditions

Ambient temperature

• During operation	• -25 to +85 °C
• During transportation and storage	• -40 to +125 °C

Degree of protection to EN 60529

- IP68
2 hours, 2 bar, +20 °C
- IPx9K
steam jet: 150 mm; 10 to 15 l/min; 100 bar; 75 °C

Shock-resistant to IEC 68-2-27	50 g ¹⁾
--------------------------------	--------------------

Vibration-resistant to IEC 68-2-6	20 g ¹⁾
-----------------------------------	--------------------

Torsion and bending load	Not permitted
--------------------------	---------------

Design, dimensions and weight

Dimensions (Ø x H)	24 x 10 mm (without set screw)
--------------------	--------------------------------

Weight	35 g
--------	------

Type of mounting	1x transponder set screw M6 SW 22; ≤ 6 Nm
------------------	--

¹⁾ The values for shock and vibration are maximum values and must not be applied continuously.

8.27.5 Dimension drawing

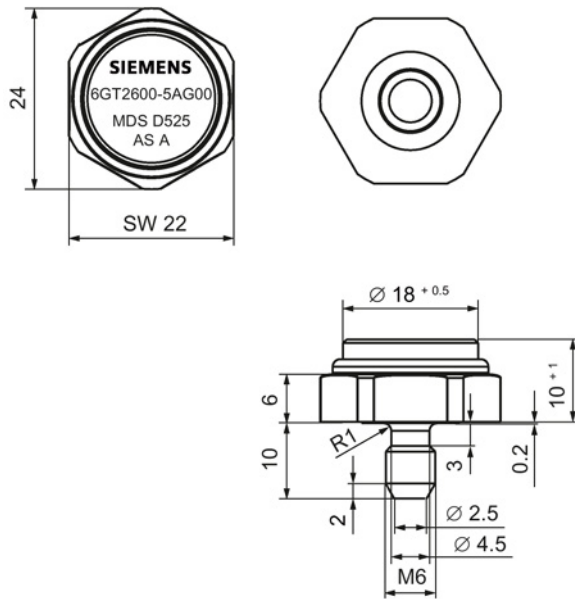



Figure 8-74 Dimensional drawing of MDS D525

All dimensions in mm

8.28 MDS D526

8.28.1 Characteristics

MDS D526	Characteristics	
	Area of application	Compact and rugged ISO transponder; suitable for identification of transport units in production-related logistics; can also be deployed in harsh conditions
	Memory size	8192 bytes of FRAM user memory
	Write/read range	See section "Field data of ISO transponders (MDS D) (Page 52)."
	Mounting on metal	Yes, with spacer
	ISO standard	ISO 15693
	Degree of protection	IP68

8.28.2 Ordering data

Table 8- 68 Ordering data for MDS D526

	Article number
MDS D526	6GT2600-5AH00

Table 8- 69 Ordering data for MDS D526 accessories

	Article number
Spacer	6GT2690-0AL00

8.28.3 Mounting on metal

Mounting on metal

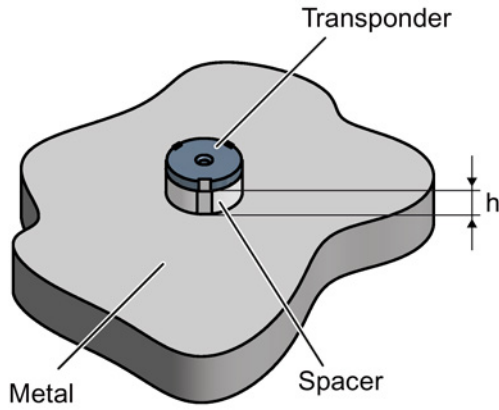

$h \geq 25 \text{ mm}$

Figure 8-75 Mounting the MDS D126 / D426 / D526 on metal with spacer

Flush-mounted in metal

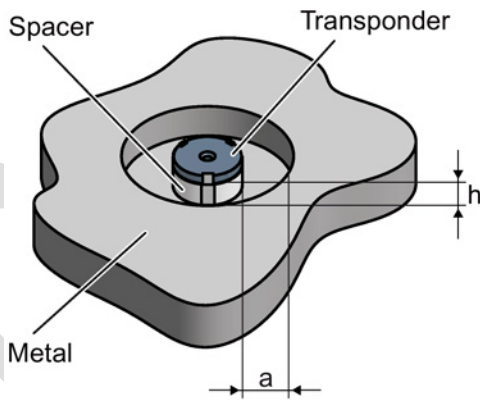

$h \geq 25 \text{ mm}$

$a \geq 50 \text{ mm}$

Figure 8-76 Flush installation of the MDS D126 / D426 / D526 in metal with spacer

8.28.4 Technical specifications

Table 8- 70 Technical specifications for MDS D526

6GT2600-5AH00	
Product type designation	SIMATIC MDS D526
Memory	
Memory configuration	
• UID	• 8 bytes
• User memory	• 8192 bytes FRAM
• OTP	• ???
Read cycles (at < 40 °C)	> 10 ¹²
Write cycles (at < 40 °C)	> 10 ¹²
Data retention time (at < 40 °C)	> 10 years
Write/read distance (S _g)	Dependent on the reader used, see section "Field data of ISO transponders (MDS D) (Page 52)"
MTBF (Mean Time Between Failures)	228 years
Mechanical specifications	
Housing	
• Material	• Plastic PA 6.6 GF
• Color	• Black
Recommended distance to metal	≥ 25 mm
Power supply	Inductive, without battery
Permitted ambient conditions	
Ambient temperature	
• During operation	• -25 to +85 °C
• During transportation and storage	• -40 to +100 °C
Degree of protection to EN 60529	IP68 2 hours, 2 bar, +20 °C
Shock-resistant to IEC 68-2-27	50 g ¹⁾
Vibration-resistant to IEC 68-2-6	20 g ¹⁾
Torsion and bending load	Not permitted

6GT2600-5AH00

Design, dimensions and weight

Dimensions (Ø x H)	50 x 3.6 mm
Weight	13 g
Type of mounting	1 x M4 screw ²⁾ ≤ 1 Nm

- 1) The values for shock and vibration are maximum values and must not be applied continuously.
- 2)) To prevent it loosening during operation, secure the screw with screw locking varnish.

8.28.5 Dimension drawing

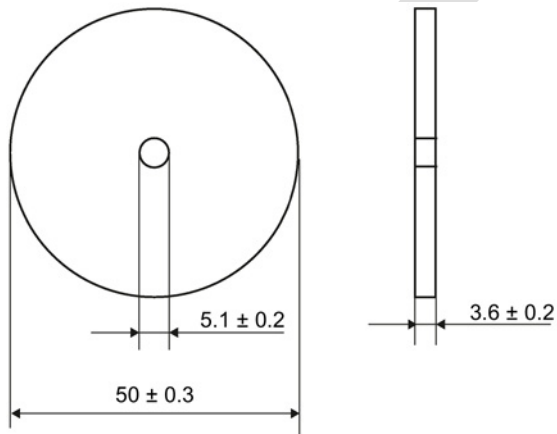



Figure 8-77 Dimensional drawing of MDS D526

All dimensions in mm

8.29 MDS D528

8.29.1 Characteristics

MDS D528	Characteristics	
	Area of application	Compact and rugged ISO transponder; suitable for screw mounting Use in assembly and production lines in the powertrain sector The rugged housing of the MDS D528 means that it can also be used in extreme environmental conditions without problems.
	Memory size	8192 bytes of FRAM user memory
	Write/read range	See section "Field data of ISO transponders (MDS D) (Page 52)"
	Mounting on metal	Yes
	ISO standard	ISO 15693
	Degree of protection	IP68/IPx9K

8.29.2 Ordering data

Table 8- 71 Ordering data for MDS D528

	Article number
MDS D528	6GT2600-5AK00

8.29.3 Application example

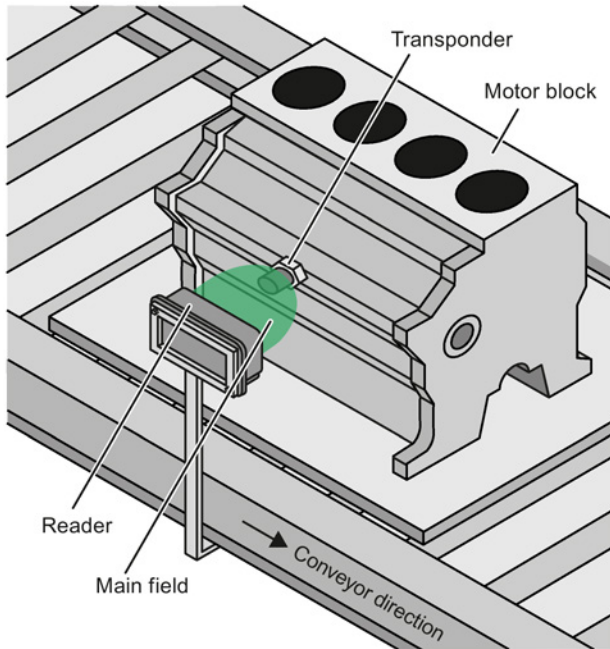

Figure 8-78 Application example

8.29.4 Technical specifications

Table 8- 72 Technical specifications for MDS D528

	6GT2600-5AK00
Product type designation	SIMATIC MDS D528
Memory	
Memory configuration	
• UID	• 8 bytes
• User memory	• 8192 bytes FRAM
• OTP	• ???
Read cycles (at < 40 °C)	> 10 ¹²
Write cycles (at < 40 °C)	> 10 ¹²
Data retention time (at < 40 °C)	> 10 years
Write/read distance (S ₉)	Dependent on the reader used, see section "Field data of ISO transponders (MDS D) (Page 52)"
MTBF (Mean Time Between Failures)	228 years

6GT2600-5AK00

Mechanical specifications**Housing**

• Material	• Plastic PA 6.6 GF
• Color	• Black
Recommended distance to metal	≥ 0 mm
Power supply	Inductive, without battery

Permitted ambient conditions**Ambient temperature**

• During operation	• -25 to +85 °C
• During transportation and storage	• -40 to +125 °C

Degree of protection to EN 60529

- IP68
2 hours, 2 bar, +20 °C
- IPx9K
steam jet: 150 mm; 10 to 15 l/min; 100 bar; 75 °C

Shock-resistant to IEC 68-2-27	50 g ¹⁾
--------------------------------	--------------------

Vibration-resistant to IEC 68-2-6	20 g ¹⁾
-----------------------------------	--------------------

Torsion and bending load	Not permitted
--------------------------	---------------

Design, dimensions and weight

Dimensions (Ø x H)	24 x 20 mm (without set screw)
--------------------	--------------------------------

Weight	35 g
--------	------

Type of mounting	1x transponder set screw M8 SW 22; ≤ 8 Nm
------------------	--

¹⁾ The values for shock and vibration are maximum values and must not be applied continuously.

8.29.5 Dimension drawing

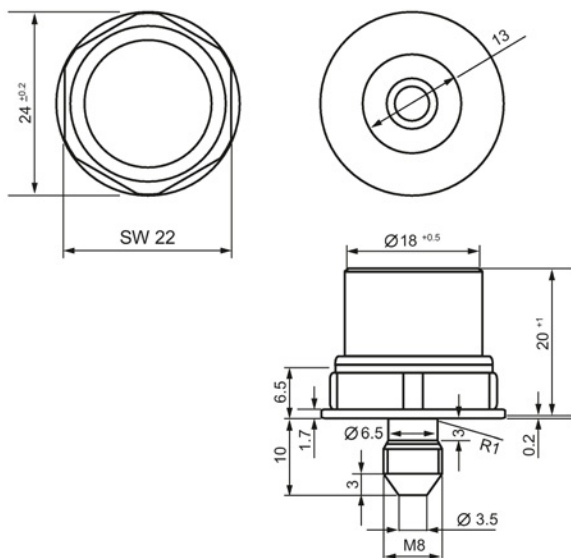

Figure 8-79 Dimensional drawing of MDS D528

All dimensions in mm

System integration

The communication modules (interface modules) are links between the RFID components (reader and transponder) and the higher-level controllers (e.g. SIMATIC S7), or PCs or computers.

9.1 Introduction

The readers are connected to the controller via the following interface or communications modules:

- ASM 456
- ASM 475
- SIMATIC RF120C
- SIMATIC RF160C
- SIMATIC RF170C
- SIMATIC RF180C
- SIMATIC RF182C
- RFID 181EIP

Function blocks, interface modules/communication modules and readers

Function blocks are used for integration into the SIMATIC. You will find information on the following blocks on the Internet in "Industry Online Support (<https://support.industry.siemens.com/cs/ww/en/ps/14971>)".

- Ident profile and Ident blocks, standard function for RFID systems
The Ident library linked into the TIA Portal as of STEP 7 Basic / Professional V14 SP 1
- RFID standard profile; standard functions for RFID systems
- FB 45 for MOBY U, MOBY D, RF200, RF300
- FB 55
- RF160C communications module with FC 44

Interface modules/communication modules and function blocks

The following table shows the most important characteristics of the interface modules/communications modules.

Table 9- 1 Overview of interface modules/communication modules

ASM/ communications module	Interfaces to the application (PLC)	Interfaces to the reader	Reader con- nections	Dimensions (W x H x D)	Temperature range	Degree of protection
ASM 456	PROFIBUS DP- V1	2 x 8-pin connector socket, M12	2 (parallel)	60 x 210 x 54 or 79 mm	0 °C to +55 °C	IP67
ASM 475	S7-300 (cen- tral), ET200M (PROFIBUS)	Via screw terminals in front connector	2	40 x 125 x 120 mm	0 °C to +60 °C	IP20
SIMATIC RF120C	S7-1200 (cen- tral)	9-pin D-sub socket	1	30 x 100 x 75 mm	0 °C to +55 °C	IP20
SIMATIC RF160C	PROFIBUS DP / DP-V0	2 x 8-pin connector socket, M12	2 (parallel)	60 x 210 x 30 mm	0 °C to +55 °C	IP67
SIMATIC RF170C	PROFIBUS DP- V1 PROFINET IO	2 x 8-pin connector socket, M12	2 (parallel)	90 x 130 x 60 mm	-25 °C to +55 °C	IP67
SIMATIC RF180C	PROFINET IO	2 x 8-pin connector socket, M12	2 (parallel)	60 x 210 x 54 mm	0 °C to +60° C	IP67
SIMATIC RF182C	TCP/IP	2 x 8-pin connector socket, M12	2 (parallel)	60 x 210 x 30 mm	0 °C to +60 °C	IP67
RFID 181EIP	Ethernet IP	2 x 8-pin connector socket, M12	2 (parallel)	60 x 210 x 54 mm	0 °C to +60° C	IP67

The following table shows the program blocks compatible with the interface modules/communications modules.

Table 9- 2 Compatible program blocks

ASM/ communications mod- ule	Compatible program blocks in conjunction with ...		
	S7-300 / S7-400 and STEP 7 Classic V5.5	S7-300 / S7-400 and STEP 7 Basic/Professional	S7-1200 / S7-1500 and STEP 7 Basic/Professional
ASM 456	FB 45 FB 55 Standard profile V1.19 Ident profile	FB 45 FB 55 Ident profile	Ident profile Ident blocks PIB_1200_UID_001KB PIB_1200_UID_032KB
ASM 475	FB 45 FB 55	FB 45 FB 55	--
SIMATIC RF120C	--	--	Ident profile Ident blocks PIB_1200_UID_001KB PIB_1200_UID_032KB
SIMATIC RF160C	FC 44 Application blocks for RF160C	FC 44 Application blocks for RF160C	Application blocks for RF160C
SIMATIC RF170C	FB 45 FB 55	FB 45 FB 55	--
SIMATIC RF180C	FB 45 FB 55 Standard profile V1.19 Ident profile	FB 45 FB 55 Ident profile	Ident profile Ident blocks PIB_1200_UID_001KB PIB_1200_UID_032KB

9.2 ASM 456

Configured with ASM 456

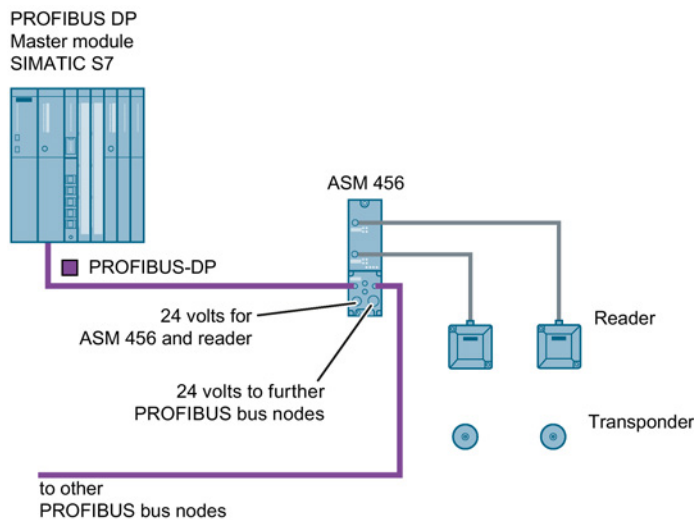

Figure 9-1 Configuration of ASM 456

For more detailed information, please refer to ASM 456 Operating Instructions (<https://support.industry.siemens.com/cs/ww/en/view/32629442>).

9.3 ASM 475

9.3.1 Features

Area of application

The ASM 475 interface module acting as the link between all RF300 systems and SIMATIC S7-300 performs the functions of a communication module. It can be operated centrally in the S7-300 or decentrally in an ET200M.

As many as eight ASM 475 interface modules can be plugged into one SIMATIC S7-300 rack and operated. In a configuration with several racks (max. four), the ASM 475 can be plugged into and operated on any rack. This means that as many as 32 ASMs can be operated in the maximum configuration of a SIMATIC S7-300. The ASM can also be operated in the ET 200M distributed I/O on PROFIBUS. Operation in an S7-400 environment is therefore problem-free. Up to 7 ASMs can be operated on each ET 200M.

Error messages and operating statuses are indicated by LEDs.

Since there is electrical isolation between the read/write device and the SIMATIC S7-300 bus, a configuration that is immune to interference is possible.



Figure 9-2 Interface module ASM 475

The ASM 475 with the article number 6GT2002-0GA10 is a module that can be set in the parameters. The basic functions of the module are then already specified when the module is configured in HW Config (e.g. standard addressing).

The data in the MDS is accessed direct by means of physical addresses using the ASM 475. Operation in a SIMATIC S7 is controlled by the function block FB 45.

ASM 475 and FB 45 form a unit that is used for reading the data of the MDS simply and at optimal speed.

9.3.2 Ordering data

Table 9- 3 Ordering data for ASM 475

	Article number
ASM 475 interface module for SIMATIC S7 2 x RF3xxR reader with RS-422 can be connected in parallel, without front connector	6GT2002-0GA10

Table 9- 4 Ordering data for ASM 475 accessories

	Article number
Front connector (1 x per ASM)	6ES7392-1AJ00-0AA0
Connecting cable ASM 475 ↔ RF3xxR	
Plug-in cable, pre-assembled, length: 2 m (standard length)	6GT2891-0EH20
Plug-in cable, pre-assembled, length: 5 m	6GT2891-0EH50
Terminal element (1 x per reader cable)	6ES7390-5BA00-0AA0
Shield connecting element	6ES7390-5AA00-0AA0

The plug-in cables 6GT2891-4Fxx can be used as extension cables.

9.3.3 Indicators

Bezel and indicator elements

The figure below illustrates the bezel of the ASM 475 and the inside of the front door complete with the associated connection diagram. The read/write devices must be connected to the ASM in accordance with the connection diagram.

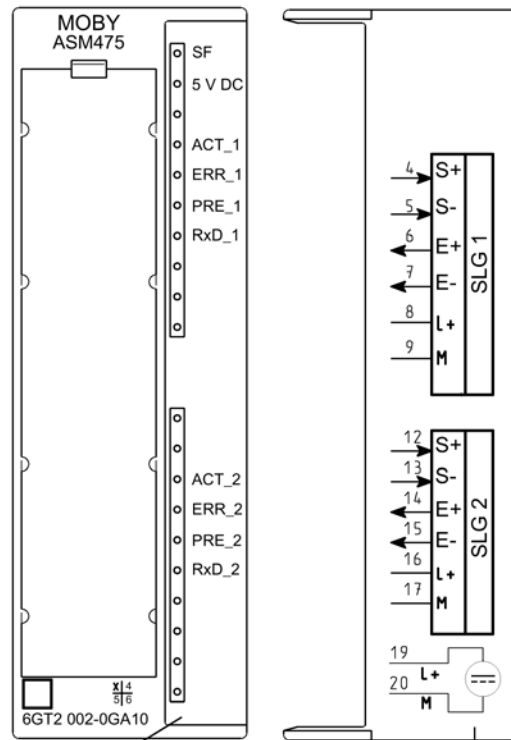

Status and error displays

Connection diagram
The numbers of the connections refer to Connector X1 of the top enclosure section

Figure 9-3 Bezel and inside of the front door of the ASM 475

Display elements on the ASM

Table 9- 5 Function of the LEDs on the ASM 475

Light emitting diode	Meaning
SF	System fault (hardware error on ASM)
DC 5V	24 V are connected to ASM and the 5 V voltage on ASM is OK.
ACT_1, ACT_2	The corresponding reader is active in processing a user command.
ERR_1, ERR_2	A flashing pattern indicates the last error to occur. This display can be reset using the parameter Option 1.
PRE_1, PRE_2	Indicates the presence of a transponder.
RxD_1, RxD_2	Indicates live communication with the reader. In the event of a fault on the reader, this display may also be lit.

On the ASM 475, further operating states are indicated with the LEDs PRE, ERR and SF:

Table 9- 6 Operating status display on ASM 475 via LEDs

SF	PRE_1	ERR_1	PRE_2	ERR_2	Meaning
ON	OFF/ON	ON (perm.)	OFF/ON	ON (perm.)	Hardware is defective (RAM, Flash, etc.)
ON	OFF	ON	OFF	OFF	Charger is defective (can only be repaired in the factory).
OFF	2 Hz	OFF	2 Hz	OFF	Firmware loading is active or no firmware detected <ul style="list-style-type: none"> Firmware download ASM must not be switched off
OFF	2 Hz	2 Hz	2 Hz	2 Hz	Firmware loading terminated with errors <ul style="list-style-type: none"> Restart required Load firmware again Check update files
Any value	5 Hz	5 Hz	5 Hz	5 Hz	Operating system error <ul style="list-style-type: none"> Switch ASM off/on
OFF	OFF	1 flash every 2 s	OFF	1 flash every 2 s	ASM has booted and is waiting for a RESET (init_run) from the user.

9.3.4 Configuration

Centralized configuration with SIMATIC S7-300

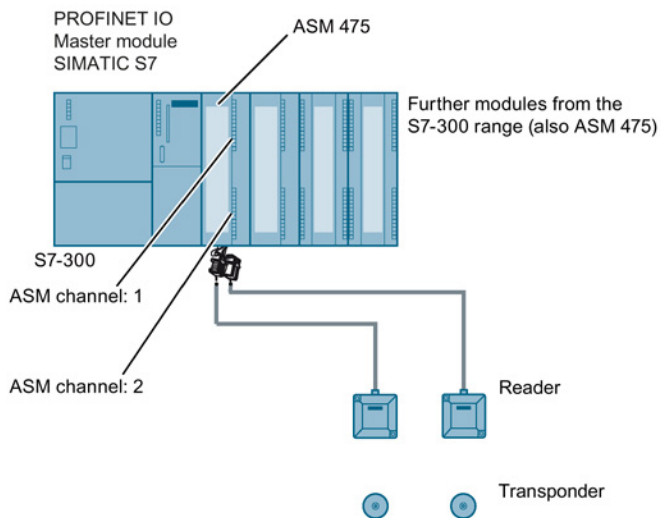

Figure 9-4 Configuration of ASM 475 central

Distributed configuration with ET200M

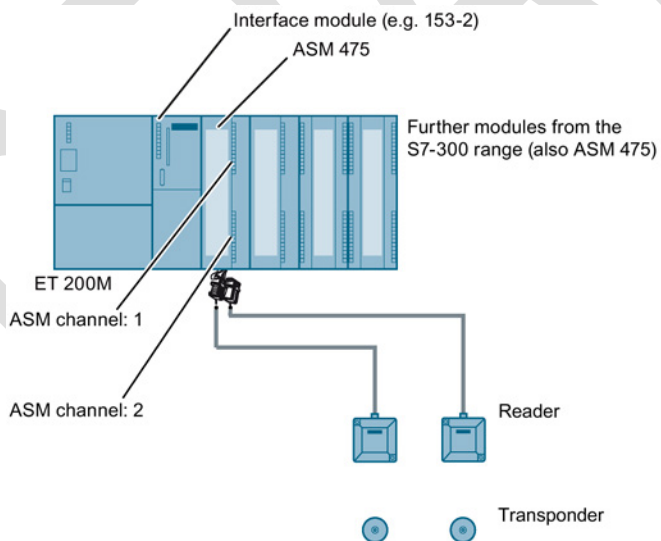

Figure 9-5 Configuration of ASM 475 distributed

Reader connection system

You will find more information on the reader connector technology in the section "Reader RF3xxR (RS422) with ASM 475 (Page 419)".

Cable installation

Signal	Pin on M12 connector	Cable	Labeling
24 VDC	1	white	1 Reader 2 8 -16
TX -	2	brown	1 Reader 2 7-15
GND	3	Green	1 Reader 2 9-17
TX +	4	Yellow	1 Reader 2 6-14
RX +	5	Gray	1 Reader 2 4-12
RX -	6	Pink	1 Reader 2 5-13
Shield	8 +	-	

Cable assignment for connection of an RF300 reader to ASM 475

9.3.5 Shield connection

When the reader is connected to the ASM 475, the cable shield must be connected to a shield terminal. Shield terminals and holding clips are standard components of the product spectrum of S7-300.

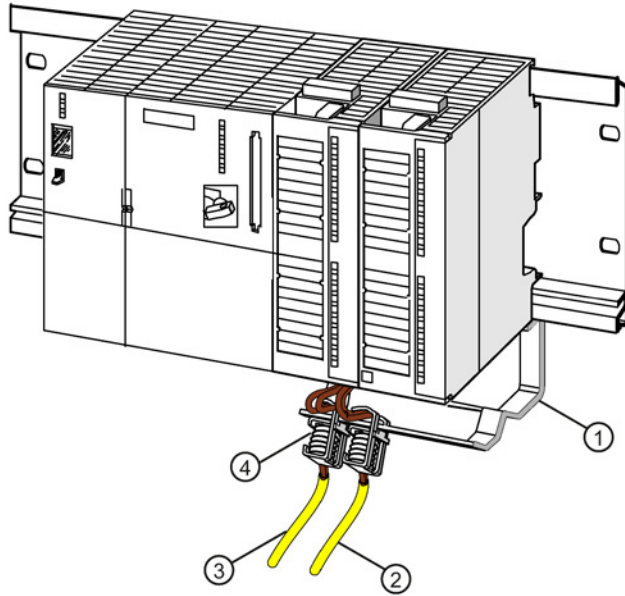

- ① Holding bracket
- ② Cable to 2nd reader
- ③ Cable to 1st reader
- ④ Shield terminal

Figure 9-6 Shield terminal ASM 475

9.3.6 Technical data

Table 9- 7 Technical specifications for ASM 475

6GT2002-0GA10	
Product type designation	ASM 475 communications module
Interfaces	
Design of the interface point-to-point link	RS-422
Number of connectable readers	2
Electrical connector design	
<ul style="list-style-type: none"> • Backplane bus • PROFIBUS interface • Industrial Ethernet interface • Supply voltage 	<ul style="list-style-type: none"> • S7-300 backplane bus • (according to the head module) • (according to the head module) • Screw-type or spring-loaded terminals
Design of the interface to the reader for communication	Screw-type or spring-loaded terminals
Mechanical specifications	
Housing	
<ul style="list-style-type: none"> • Material • Color 	<ul style="list-style-type: none"> • Noryl • Anthracite
Supply voltage, current consumption, power loss	
Supply voltage	24 VDC
Typical current consumption	
<ul style="list-style-type: none"> • Without connected devices • Including connected devices 	<ul style="list-style-type: none"> • 0.1 A • 1.0 A
Power dissipation of the module, typ.	2 Watts
Current consumption from I/O bus, max.	80 mA
Electrical isolation between S7-300 and RF300	Yes
Fuse 24 V for the reader	Yes, electronic

6GT2002-0GA10

Permitted ambient conditions

Ambient temperature

- During operation (horizontal installation) 0 ... +60 °C
- During operation (vertical installation) 0 ... +40 °C
- During transportation and storage -40 ... +70 °C

Degree of protection IP20

Shock-resistant to IEC 61131-2 150 m/s²Vibration-resistant to IEC 61131-2 10 m/s²**Design, dimensions and weight**

Dimensions (L x W x H) 120 x 40 x 125 mm

Weight 0.2 kg

Type of mounting S7-300 rack

Cable length for RS-422 interface, maximum 1000 m

Product properties, functions, components general

LED display design

- 4 LEDs per reader connector
- 2 LEDs for device status

Product function transponder file handler addressable Yes

Protocol supported S7 communication Yes

Product functions management, configuration, engineering

Type of parameter assignment Object manager, GSD

Type of programming FB 45, FB 55, FC 56
(FC 45/55 with restricted functionality)

Type of computer-based communication 2 words cyclic, 238 bytes acyclic

Transponder addressing Direct access via addresses

Commands Initialize transponder, read data from transponder, write data to transponder

Standards, specifications, approvals

Proof of suitability CE, FCC, UL/CSA

9.4 RF120C

Configuration with RF120C



Figure 9-7 Configuration RF120C

For more detailed information, refer to the section " RF120C communications module (<https://support.industry.siemens.com/cs/ww/en/view/77485950>)".

9.5 RF160C

Configuration with RF160C

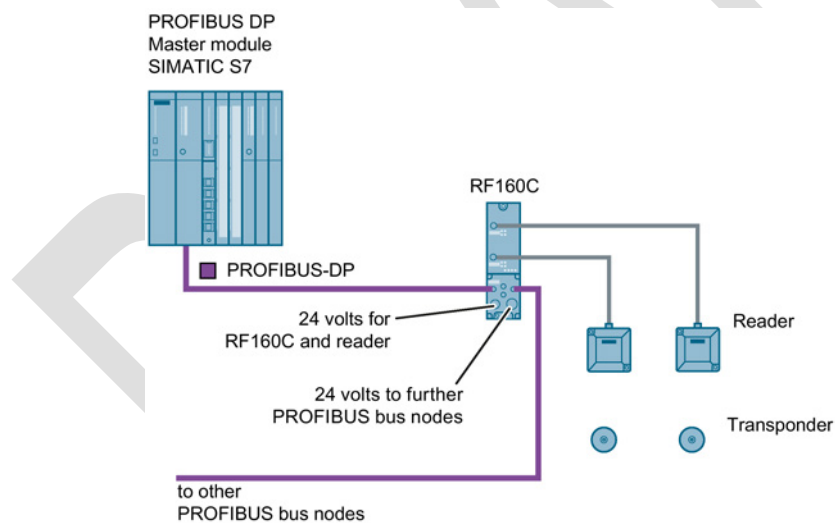

Figure 9-8 Configuration RF160C

For more detailed information, refer to Operating Instructions RF160C (<https://support.industry.siemens.com/cs/ww/en/view/42788808>).

9.6 RF170C

Configuration with RF170C

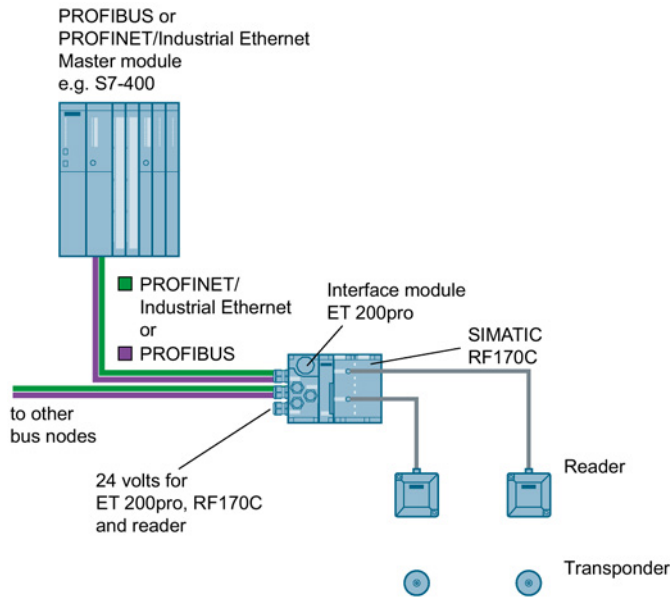

Figure 9-9 Configuration RF170C

For more detailed information, please refer to SIMATIC RF170C Operating Instructions (<https://support.industry.siemens.com/cs/ww/en/view/32622825>).

9.7 RF180C

Configured with RF180C

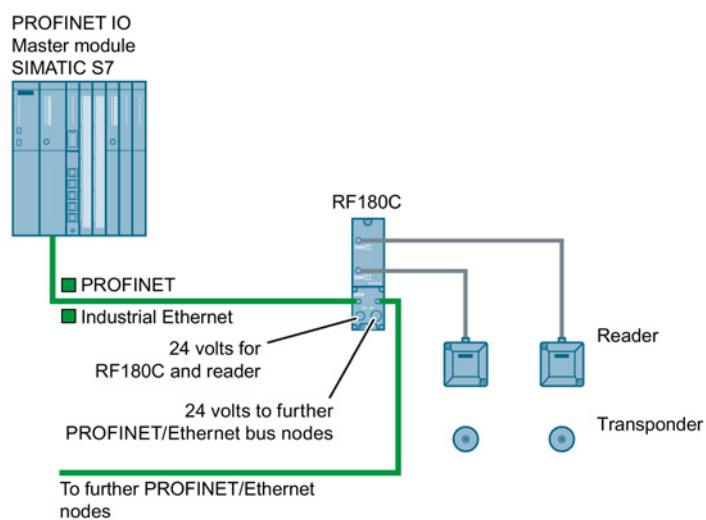

Figure 9-10 Configuration of RF180C

For more detailed information, refer to SIMATIC RF180C Operating Instructions (<https://support.industry.siemens.com/cs/ww/en/view/30012157>).

9.8 RF182C

Configuration with RF182C

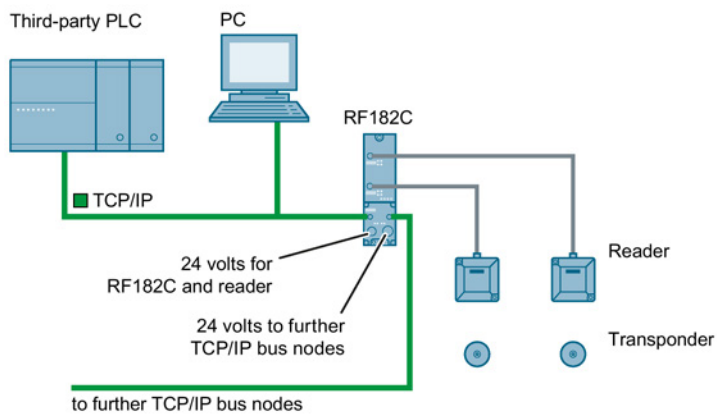

Figure 9-11 Configuration with RF182C

For more detailed information, refer to SIMATIC RF182C Operating Instructions (<https://support.industry.siemens.com/cs/ww/en/view/38507897>).

System diagnostics

10.1 Error codes

Error codes of the RF300 readers

Note**Validity of the error codes**

The following error codes apply only to RF300 readers with an RS-422 interface (except for Scanmode).

You can identify the error code in different ways:

- Directly on the reader/interface module by counting the flashing pattern of the red error LED
- In the Ident profile with the output variable "Status"
- with FB 45 / FB 55 variable "error_MOBY".

Table 10- 1 Error codes of the readers

Flashing of the red LED operating display on the reader	Error code (hexa-decimal)	Description
00	00	No error
02	01	Presence error; possible causes: <ul style="list-style-type: none"> • The active command was not carried out completely • The transponder left the antenna field while the command was being processed • Communication problem between reader and transponder
05	05	Parameter assignment error, possible causes: <ul style="list-style-type: none"> • Unknown command • Incorrect parameter • Function not allowed
06	06	Air interface faulty
11	0B	The MDS E transponder could not be successfully authenticated.
12	0C	The transponder memory cannot be written, possible causes: <ul style="list-style-type: none"> • Hardware fault (memory faulty) • Memory write-protected (corresponding OTP area has already been written)
13	0D	Error in the specified memory address (access attempted to non-existent or non-accessible memory areas).
19	13	Buffer overflow: Insufficient buffer available in the reader for saving the command
20	14	Major system fault (hardware fault)
21	15	Parameter assignment error: bad parameter in RESET command
24	18	Command was sent to a reader that has not yet been initialized
25	19	Previous command is still active
28	1C	Antenna is not identified Possible causes: <ul style="list-style-type: none"> • Antenna is not connected. • Antenna cable is defective.
30	1E	Incorrect number of characters in frame
31	1F	Running command cancelled by "RESET" command

10.2 Diagnostics functions - STEP 7 Classic

10.2.1 Overview

Extended diagnostic functions with SIMATIC RF300

With SIMATIC RF300, extended diagnostics functions are available which simplify commissioning and maintenance.

This diagnostics data is accessed using the SIMATIC function blocks via the SLG Status and MDS Status commands. These two commands can each be called in various modes (subcommands) for which corresponding data structures (UDTs) are defined.

Table 10- 2 In RF300 mode

Command	Mode (subcommand)	Meaning
SLG-STATUS	01	Hardware and firmware configuration, parameterization status
	06	Communication error counter, current command status
MDS-STATUS	01	Serial number of the transponder (UID), memory configuration. EEPROM write-protection status
	02	Serial number of the transponder (UID), HF field strength value, communication error counter, presence counter (duration)

Overview of the diagnostic functions

Table 10- 3 In ISO mode

Command	Mode (subcommand)	Meaning
SLG-STATUS	01	Hardware and firmware configuration, parameterization status
MDS-STATUS	03	Serial number of the transponder (UID), recognized transponder type number in the field (number = tag - type, see reset parameter "ftim"), memory configuration, write protect status (OTP), size and number of blocks in the user memory

10.2.2 Reader diagnostics with SLG STATUS

The SLG STATUS command can be used to scan the status and diagnostics data of the reader.

SLG STATUS (mode 01), corresponds to UDT 110

Name	Type	Possible Hex values	Comment
hardware	char	(31 ... 38)	Type of hardware
hardware_version	word	0 ... FF 0 ... FF	HW version = Version (high byte): Unused = Version (low byte)
loader_version	word	0 ... FF 0 ... FF	Version of loader = Version (high byte) = Version (low byte)
firmware	char	0 ... FF	Type of firmware
firmware_version	word	0 ... FF 0 ... FF	Firmware version = Version (high byte) = Version (low byte)
driver	char	31	Type of driver 3964R
driver_version	word	0 ... FF 0 ... FF	Version of driver = Version (high byte) = Version (low byte)
interface	byte	01 02	Interface type = RS422 = RS232 (only RF380R)
baud	byte	01 03 05	Transmission speed = 19.2 Kbaud = 57.6 Kbaud = 115,2 Kbaud
distance_limiting_SLG	byte	This variable is only provided for the RF380R. Users are therefore able to check the output power actually set. An incorrect value in the parameter "distance_limiting" of the RESET message frame results in the default setting "05".	
			Transmit power
		02	0.5 W
		03	0.75 W
		04	1.0
		05	1.25 W (default)
		06	1.5 W
		07	1.75 W
		08	2.0 W

Name	Type	Possible Hex values	Comment
multitag_SLG	byte	01	Number of transponders (Multi/Pulk) that can be processed in the antenna field = Single tag mode
field_ON_time_SLG	byte	00 01 03 04 05 06 07 08 0E 10 20 31 FF	= RF300 transponder = ISO transponder (non-specific) = ISO transponder (Infineon, MDS D300) = ISO transponder (Fujitsu, MDS D400) = ISO transponder (NXP, MDS D100) = ISO transponder (Texas Instruments, MDS D200) = ISO transponder (ST, LRI2K) = ISO transponder (Fujitsu, MDS D500) = ISO (setting with "scanning_time" and "fcon") = RF300 transponder = MDS E transponder = General Mode = Setting with "scanning_time" and "fcon"
status_ant	byte	01 02	Status of the antenna = Antenna On = Antenna Off
MDS_control	byte	00 01 04	Presence mode = Operation without presence message = Operation with presence message = Operation with presence message (antenna is off. The antenna is turned on only when a Read or Write command is sent.)

SLG STATUS (mode 06), corresponds to UDT 280

Name	Type	Possible Hex values	Comment
FZP	byte	0 ... FF	= Error counter, passive (errors during idle time)
ABZ			= Abort counter
CFZ			= Code error counter
SFZ			= Signature error counter
CRCFZ			= CRC error counter
BSTAT			= Current command status
ASMfZ			= Interface problems to host (ASM/PC) parity, BCC, frame error

Note

Counter values are deleted.

All counter values are deleted after reading out (= execute "SLG STATUS" command).

Explanations:

- "FZP": counts interference pulses when communication with a transponder is not taking place (e.g. electromagnetic interference caused by contactors, motors, etc.). Counter values can, however, also be generated when a transponder is located at the edge of the field even when there is no external interference.
- "ABZ", "CFZ", "SFZ" and "CRCFZ" are counters for protocol errors which may occur during reader-transponder communication. This can be caused by unsuitable reader/transponder positioning (e.g. transponder on field boundary, several transponders in the antenna field) or external EMC interference.

To ensure clear diagnosis of the quality of communication, it is recommended that an SLG STATUS command (mode 06) is executed following receipt of the presence command to reset the error counter.

The protocol error counters are not mutually independent. If a code error (CFZ) occurs, this will cause a signature (SFZ) or CRC- (CRCFZ) error.

- "BSTAT" is the status for the most recently executed command. A value other than 0 means that the previous command was repeated by the reader due to faults (see above).
- "ASMZ" signals line-conducted communication interference between the communications module and the reader. Faults of this type can be caused by contact problems on the connector or the cable connection.

10.2.3 Transponder diagnostics with MDS STATUS

The MDS STATUS command can be used to scan the status and diagnostics data of the transponder that is located within the antenna field.

MDS STATUS (mode 1), corresponds to UDT 260 (only for RF300 transponders)

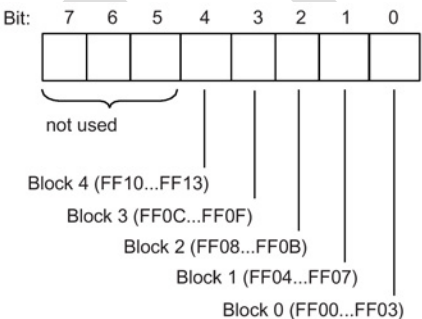
Name	Type	Possible Hex values	Comment
UID	array[1...8] byte	0000000055555555 ... 00000000FFFFFFFF	Unique identifier = b0-31: 4 byte TAG ID, b32-63: 0
MDS_type	byte	01 02 03 04	Transponder memory configuration = Transponder without FRAM = Transponder with FRAM 8 KB = Transponder with FRAM 32 KB = Transponder with FRAM 64 KB
Lock_state	byte	0 ... FF	EEPROM write protection status  <p>Write protection status: 0 = block not protected (r/w) 1 = block protected (ro)</p>

MDS STATUS (mode 02), corresponds to UDT 270, only for RF300 transponders

Name	Type	Possible Hex values	Comment
UID	array[1...8] byte	0000000055555555 ... 00000000FFFFFFFF	Unique identifier = b0-31: 4 byte TAG ID, b32-63: 0
LFD	byte	0 ... FF	= Value for field strength determined in the transponder
FZP	byte	0 ... FF	= Error counter (passive) → errors during idle time
FZA	byte	0 ... FF	= Error counter (active)
ANWZ	byte	0 ... FF	= Presence counter

Note

Counter values are deleted.

All counter values are deleted when the transponder exits the antenna field or when the antenna is switched off.

Explanations:

- "LFD" is a measured value for the field strength that is determined in the transponder. The lower the value, the higher the field strength.
- "FZP" counts interference pulses when communication with a transponder is not taking place (e.g. electromagnetic interference caused by contactors, motors, etc.). Counter values can also be generated when a transponder is located at the edge of the field even when there is no external interference.
- "FZA" counts errors that can occur during reader-to-transponder communication. This can be caused by unsuitable reader/transponder positioning (e.g. transponder on field boundary, several data carriers in the field) or external electromagnetic interference.
- "ANWZ" is the value for the time that the transponder remains in the field before the MDS STATUS command (mode 02) is executed. A time step is 10 ms. The maximum time that can be recorded is therefore 2.5 s.

MDS STATUS (mode 03), corresponds to UDT 230

Name	Type	Possible Values	Comment
UID	array[1...8] byte	0000000000000000 ... FFFFFFFFFFFFFFFF	Unique identifier =8 byte UID, MSB first
MDS_type	byte	00 03 04 05 06 07 08 11 12 13 14 15 16 21 22 23	Transponder type (vendor, identification) = ISO transponder (non-specific) = ISO transponder (Infineon, MDS D300) = ISO transponder (Fujitsu, MDS D400) = ISO transponder (Philips, MDS D100) = ISO transponder (Texas Instruments, MDS D200) = ISO transponder (ST, LRI2K) = ISO transponder (Fujitsu, MDS D500) = RF300 transponder (0 kB) = RF300 transponder (8 kB) = RF300 transponder (32 kB) = RF300 transponder (64 kB) = RF300 transponder (128 kB) = RF300 transponder (256 kB) = ISO transponder (NXP, 1 kB, MDS E) = ISO transponder (Infineon, 1 kB, MDS E) = ISO transponder (NXP, 4 kB)

Name	Type	Possible Values	Comment
	binary	0 ... 255	Vendor-specific value
IC_version	byte	0 ... FF	Chip version
size	byte	0 ... FF	Memory size in bytes Depending on transponder type, e.g. my-d: 992 bytes
lock_state	byte	0 ... FF	Lock state, OTP information: One bit is used per block (4 x 4 bytes or 2 x 8 bytes) (bit = 1: block is locked) Example: 01 = Block 1 of address FF80 ... FF83 is locked or 03 = Block 1 and 2 of address FF80 ... FF87 are locked, e.g. for the Philips SL2 ICS20 (MDS D124, D160 or D100). This chip provides a usable memory with 112 bytes EEPROM from address 0000 - 006F (total OTP area "0060 ... 006F"). In this memory, the locked area corre- sponds to the addresses 0060 ... 0063 or 0060 ... 0067
block_size	byte	0 ... FF	Block size of the transponder Depending on transponder type, e.g. my-d: 4 bytes
nr_of_blocks	byte	0 ... FF	Number of blocks Depending on transponder type, e.g. my-d: 248 bytes

10.3 Diagnostics functions STEP 7 Basic / Professional

Extensive diagnostics functions for the SIMATIC RF300 readers with STEP 7 Basic / Professional are being planned. With the aid of the Ident profile and the Ident blocks, you can make different diagnostics queries.

DRAFT