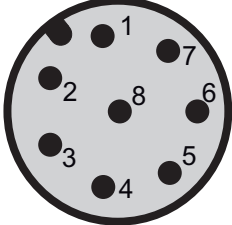

## 5.3 RF310R with RS422 interface

### 5.3.1 Features

Reader RF310R	Features	
	Structure	① RS422 interface ② Status display
	Field of application	Identification tasks on small assembly lines in harsh industrial environments
	Read/write distance to transponder	Max. 30 mm
	Data transmission rate	<ul style="list-style-type: none"> <li>• Read: approx. 3100 byte/s</li> <li>• Write: approx. 3100 byte/s</li> </ul>

### 5.3.2 Pin assignment of RF310R RS422 interface

Pin	Pin Device end 8-pin M12	Assignment
	1	+ 24 V
	2	- Transmit
	3	0 V
	4	+ Transmit
	5	+ Receive
	6	- Receive
	7	Free
	8	Earth (shield)

### 5.3.3 Display elements of the RF310R reader with RS422 interface

Color		Meaning
Green	Flashing	Operating voltage present, reader not initialized or antenna switched off
	Permanently on	Operating voltage present, reader initialized and antenna switched on
Yellow <sup>1)</sup>		Transponder present
Flashing red		Error has occurred, the type of flashing corresponds to the error code in the table in Section "Error codes". The optical error display is only reset if the corresponding reset parameter ("option_1", see FC45 / FB45 documentation, Section "Input parameters") is set.

<sup>1)</sup> In the operating state "Without presence", the lighting duration may be very short.

### 5.3.4 Ensuring reliable data exchange

The "center point" of the transponder must be situated within the transmission window.

### 5.3.5 Metal-free area

The RF310R can be flush-mounted in metal. Please allow for a possible reduction in the field data values.

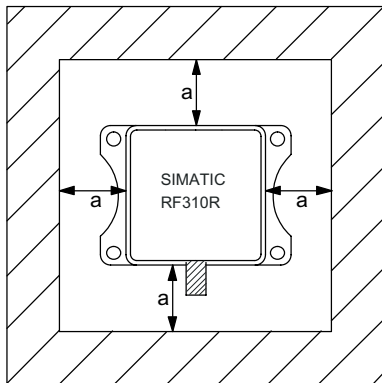

Figure 5-4 Metal-free area for RF310R

To avoid any impact on the field data, the distance a should be  $\geq 20$  mm.

### 5.3.6 Minimum distance between RF310R readers

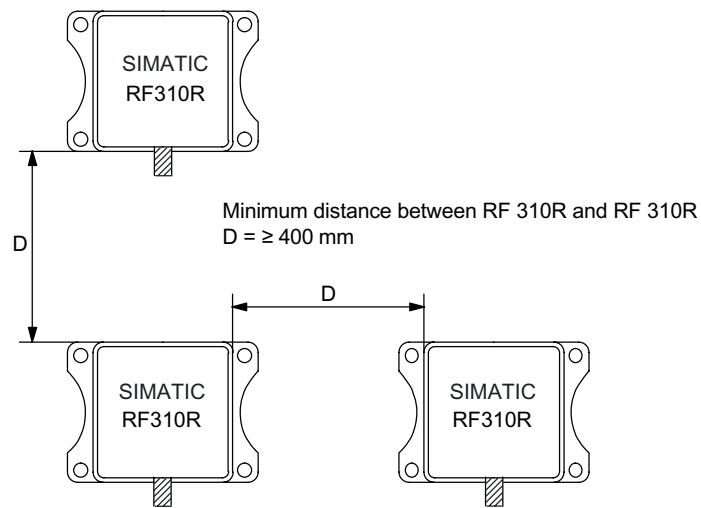

Figure 5-5 Minimum distance between RF310R readers

### 5.3.7 Technical specifications of the RF310R reader with RS422 interface

Table 5-3 Technical specifications of the RF310R reader with RS422 interface

Inductive interface to the transponder	
Transmission frequency for power/data	13.56 MHz
Antenna	Integrated
Interface to communication module	RS422 (3964R protocol)
Baud rate	19200 baud, 57600 baud, 115200 baud
Cable length between reader and communication module	Data cable length max. 1000 m (shielded cable)
Read/write distances of reader	See RF310R field data
Minimum distance between two RF310R readers	≥ 400 mm
Maximum data transfer rate from reader to transponder (Tag)	
Reading	Approx. 3100 byte/s
Writing	Approx. 3100 byte/s
Functions	Initialize/read/write transponder Scan status and diagnostics information Switch antenna on/off Repeat command Scan transponder serial numbers
Power supply	24 V DC
Display elements	2-color LED (operating voltage, presence, error)
Plug connector	M12 (8-pin)
Enclosure	
Dimensions (in mm)	55 x 75 x 30 (without M12 device connector)
Color	Anthracite
Material	Plastic PA 12
Fixing	4 x M5 screws
Ambient temperature during operations	-25 °C to +70 °C
during transport and storage	-40 °C to +85 °C
Degree of protection to EN 60529	IP67
Shock to EN 60 721-3-7 Class 7 M2	50 g
Vibration to EN 60 721-3-7 Class 7 M2	20 g
Weight	Approx. 200 g
MTBF (Mean Time Between Failures) in years	169,9
Approvals	Radio to R&TTE guidelines EN 300 330, EN 301489, CE, FCC, UL/CSA
Current consumption	typ. 40 mA

### 5.3.8 FCC information

#### Siemens SIMATIC RF310R with RS422 interface

FCC ID: NXW-RF310R

This device complies with Part 15 of the FCC rules. Operation is subject to the following two conditions:

- (1) This device may not cause harmful interference.
- (2) This device must accept any interference received, including interference that may cause undesired operation.

#### Caution

Any changes or modifications not expressly approved by the party responsible for compliance could void the user's authority to operate the equipment.

### 5.3.9 Ordering data for RF310R with RS422 interface

RF310R	Order No.
With RS422 interface (3964R) IP 67, -25 °C to +70 °C, 55 x 75 x 30 (L x W x H in mm), with integrated antenna, max. limit distance 30 mm (depending on transponder)	6GT2801-1AA10

### 5.3.10 Dimension drawing

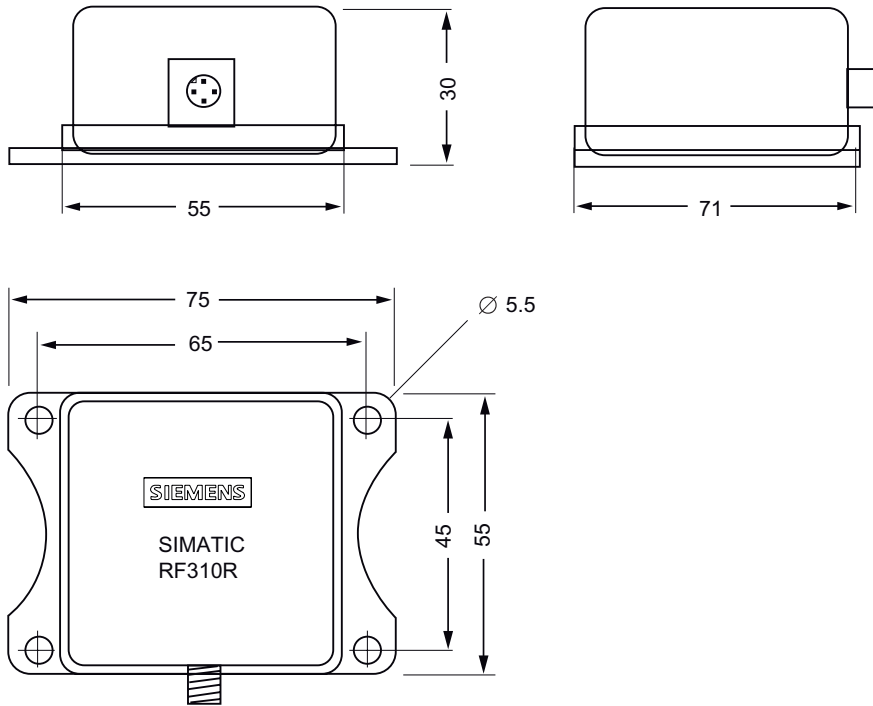



Figure 5-6 Dimension drawing for RF310R

Dimensions in mm

## 5.4 RF340R

### 5.4.1 Features

Reader RF340R	Features	
	Design	<ul style="list-style-type: none"> <li>① RS422 interface</li> <li>② Status display</li> </ul>
	Area of application	Identification tasks on assembly lines in harsh industrial environments
	Read/write distance to transponder	max. 60 mm
	Data transmission rate	<ul style="list-style-type: none"> <li>• Read: approx. 3,100 byte/s</li> <li>• Write: approx. 3,100 byte/s</li> </ul>

### 5.4.2 Pin assignment of RF340R RS422 interface

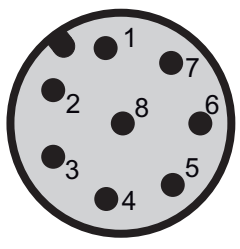
Pin	Pin Device end 8-pin M12	Assignment
	1	+ 24 V
	2	- Transmit
	3	0 V
	4	+ Transmit
	5	+ Receive
	6	- Receive
	7	Free
	8	Earth (shield)

### 5.4.3 Display elements of the RF340R reader

Color		Meaning
Green	Flashing	Operating voltage present, reader not initialized or antenna switched off
	Permanently on	Operating voltage present, reader initialized and antenna switched on
Yellow <sup>1)</sup>		Transponder present
Flashing red		Error has occurred, the type of flashing corresponds to the error code in the table in Section "Error codes". The optical error display is only reset if the corresponding reset parameter ("option_1", see FC45 / FB45 documentation, Section "Input parameters") is set.

<sup>1)</sup> In the operating state "Without presence", the lighting duration may be very short.

### 5.4.4 Ensuring reliable data exchange

The "center point" of the transponder must be situated within the transmission window.

### 5.4.5 Metal-free area

The RF340R can be flush-mounted in metal. Please allow for a possible reduction in the field data values.

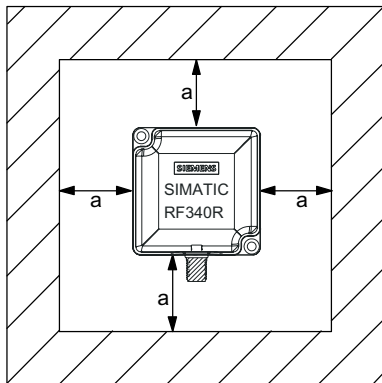

Figure 5-7 Metal-free area for RF340R

To avoid any impact on the field data, the distance a should be  $\geq 20$  mm.



### 5.4.6 Minimum distance between RF340R readers

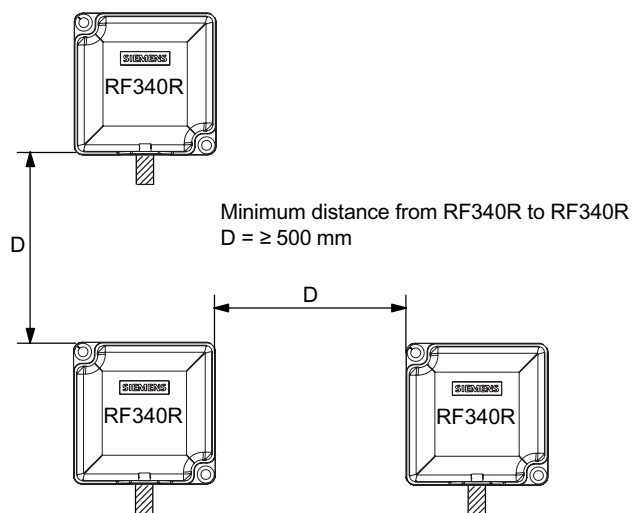

Figure 5-8 Minimum distance between RF340R readers

## 5.4.7 Technical data of the RF340R reader

Table 5-4 Technical specifications of the RF340R reader

Inductive interface to the transponder	
Transmission frequency for power/data	13.56 MHz
Antenna	Integrated
Interface to communication module	RS422 (3964R protocol)
Baud rate	19200 baud, 57600 baud, 115200 baud
Cable length between reader and communication module	Data cable length max. 1000 m (shielded cable)
Read/write distances of reader	See RF340R field data
Minimum distance between two RF340R readers	≥ 500 mm
Maximum data transfer rate reader - transponder (tag)	
Reading	Approx. 3100 byte/s
Writing	Approx. 3100 byte/s
Functions	Initialize/read/write transponder Scan status and diagnostics information Switch antenna on/off Repeat command Scan transponder serial numbers
Power supply	24 V DC
Display elements	2-color LED (operating voltage, presence, error)
Plug connector	M12 (8-pin)
Enclosure	
Dimensions (in mm)	75 x 75 x 40 (without M12 device connector)
Color	Anthracite
Material	Plastic PA 12
Fixing	2 x M5 screws
Ambient temperature during operations	-25 °C to +70 °C
during transport and storage	-40 °C to +85 °C
Degree of protection to EN 60529	IP 67
Shock to EN 60 721-3-7 Class 7 M2	50 g
Vibration to EN 60 721-3-7 Class 7 M2	20 g
Weight	Approx. 250 g
MTBF (Mean Time Between Failures) in years	140,3
Approvals	Radio to R&TTE guidelines EN 300 330, EN 301489, CE, FCC, UL/CSA
Current consumption	typ. 100 mA

## 5.4.8 FCC information

### Siemens SIMATIC RF340R

FCC ID: NXW-RF340R

This device complies with Part 15 of the FCC rules. Operation is subject to the following two conditions:

- (1) This device may not cause harmful interference.
- (2) This device must accept any interference received, including interference that may cause undesired operation.

### Caution

Any changes or modifications not expressly approved by the party responsible for compliance could void the user's authority to operate the equipment.

## 5.4.9 Ordering data for RF340R

Product description	Order No.
Reader RF340R With RS422 interface (3964R) IP67; -25 °C to +70 C, dimensions 75 x 91 x 41 (L x W x H in mm); with integrated antenna; max. limit distance 65 mm (depending on transponder)	6GT2801-2AA10

### 5.4.10 Dimension drawing

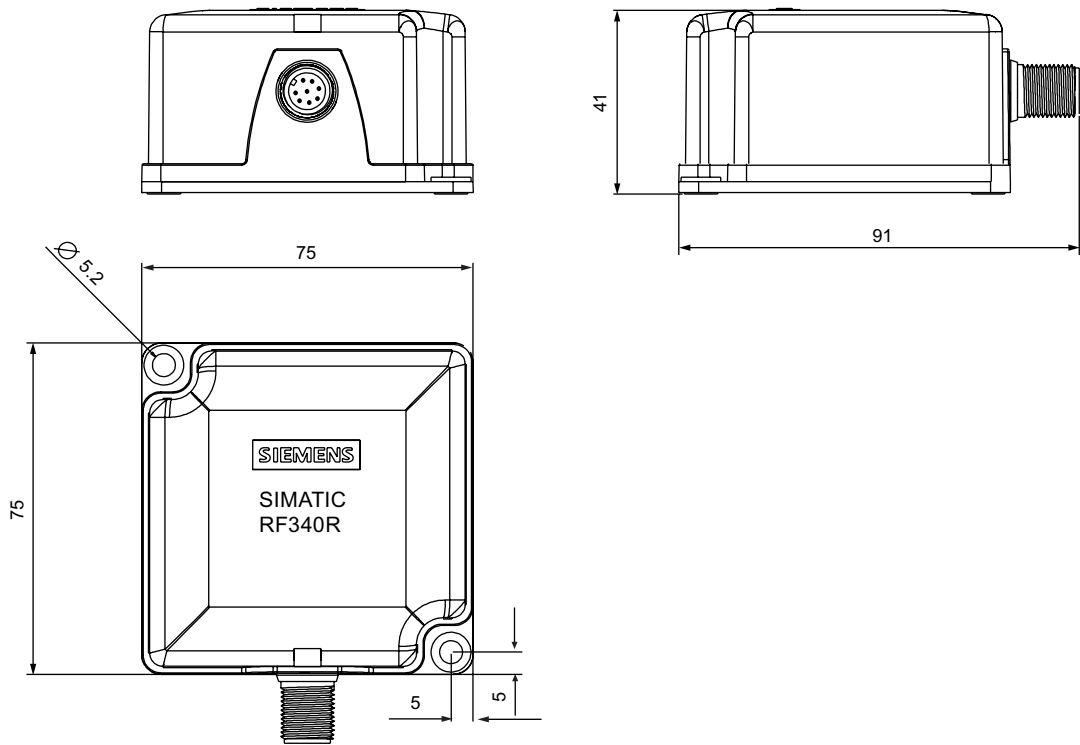



Figure 5-9 Dimension drawing for RF340R

Dimensions in mm

## 5.5 RF350R

### 5.5.1 Features

Reader RF350R	Features	
	Design	<ul style="list-style-type: none"> <li>① Antenna connection</li> <li>② RS422 interface</li> <li>③ Status display</li> </ul>
	Area of application	Identification tasks in assembly lines in harsh industrial environments; for external antennas (ANT 1, ANT 18, ANT 30)
	Read/write distance to transponder	Max. 60 mm
	Data transmission rate	<ul style="list-style-type: none"> <li>• Read: approx. 3,100 byte/s</li> <li>• Write: approx. 3,100 byte/s</li> </ul>

### 5.5.2 Pin assignment of RF350R RS422 interface

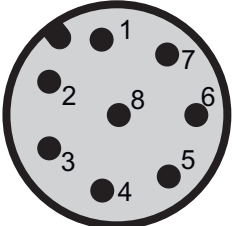
Pin	Pin Device end 8-pin M12	Assignment
	1	+ 24 V
	2	- Transmit
	3	0 V
	4	+ Transmit
	5	+ Receive
	6	- Receive
	7	Free
	8	Earth (shield)

### 5.5.3 Display elements of the RF350R reader

Color		Meaning
Green	Flashing	Operating voltage present, reader not initialized or antenna switched off
	Permanently on	Operating voltage present, reader initialized and antenna switched on
Yellow <sup>1)</sup>		Transponder present
Flashing red		Error has occurred, the type of flashing corresponds to the error code in the table in Section "Error codes". The optical error display is only reset if the corresponding reset parameter ("option_1", see FC45 / FB45 documentation, Section "Input parameters") is set.

<sup>1)</sup> In the operating state "Without presence", the lighting duration may be very short.

### 5.5.4 Ensuring reliable data exchange

The "center point" of the transponder must be situated within the transmission window.

### 5.5.5 Metal-free area

The RF350R reader does not have an internal antenna. Operation is not affected by mounting on metal or flush-mounting in metal. For information about the metal-free area required by the external antennas, refer to the corresponding section of the chapter Antennas (Page 110).

## 5.5.6 Technical data of the RF350R reader

Table 5-5 Technical specifications of the RF350R reader

Inductive interface to the transponder	
Transmission frequency for power/data	13.56 MHz
Antenna	External, plug-in MOBY E antennas ANT 1, ANT 18 or ANT 30
Interface to communication module	RS422 (3964R protocol)
Baud rate	19200 baud, 57600 baud, 115 baud
Cable length between reader and communication module	Data cable length max. 1000 m (shielded cable)
Read/write distances of reader	See field data
Minimum distance between two antennas	See field data
Maximum data transfer rate reader - transponder (tag)	
Reading	Approx. 3100 byte/s
Writing	Approx. 3100 byte/s
Functions	Initialize/read/write transponder Scan status and diagnostics information Switch antenna on/off Repeat command Scan transponder serial numbers
Power supply	24 V DC
Display elements	2-color LED (operating voltage, presence, error)
Plug connector	M12 (8-pin); M8 (4-pin) for antenna
Enclosure	
Dimensions (in mm)	75 x 75 x 40 (without M12 device connector)
Color	Anthracite
Material	Plastic PA 12
Fixing	2 x M5 screws
Ambient temperature during operations	-25 °C to +70 °C
during transport and storage	-40 °C to +85 °C
Degree of protection to EN 60529	IP65
Shock to EN 60 721-3-7 Class 7 M2	50 g
Vibration to EN 60 721-3-7 Class 7 M2	20 g
Weight	Approx. 400 g
MTBF (Mean Time Between Failures) in years	109
Approvals	Radio to R&TTE guidelines EN 300 330, EN 301489, CE, FCC, UL/CSA
Current consumption	typ. 100 mA

### 5.5.7 FCC information

#### Siemens SIMATIC RF350R

FCC ID: NXW-RF350R

This device complies with Part 15 of the FCC rules. Operation is subject to the following two conditions:

- (1) This device may not cause harmful interference.
- (2) This device must accept any interference received, including interference that may cause undesired operation.

#### Caution

Any changes or modifications not expressly approved by the party responsible for compliance could void the user's authority to operate the equipment.

### 5.5.8 Ordering data for RF350R

Product description	Order No.
Reader RF350R With RS422 interface (3964R) IP 65; -25 °C to +70 °C, dimensions 75 x 96 x 41 (L x W x H in mm); for plug-in antennas from the MOBY E product range; max. limit distance 65 mm (depending on transponder)	6GT2801-4AA10



### 5.5.9 Dimension drawing

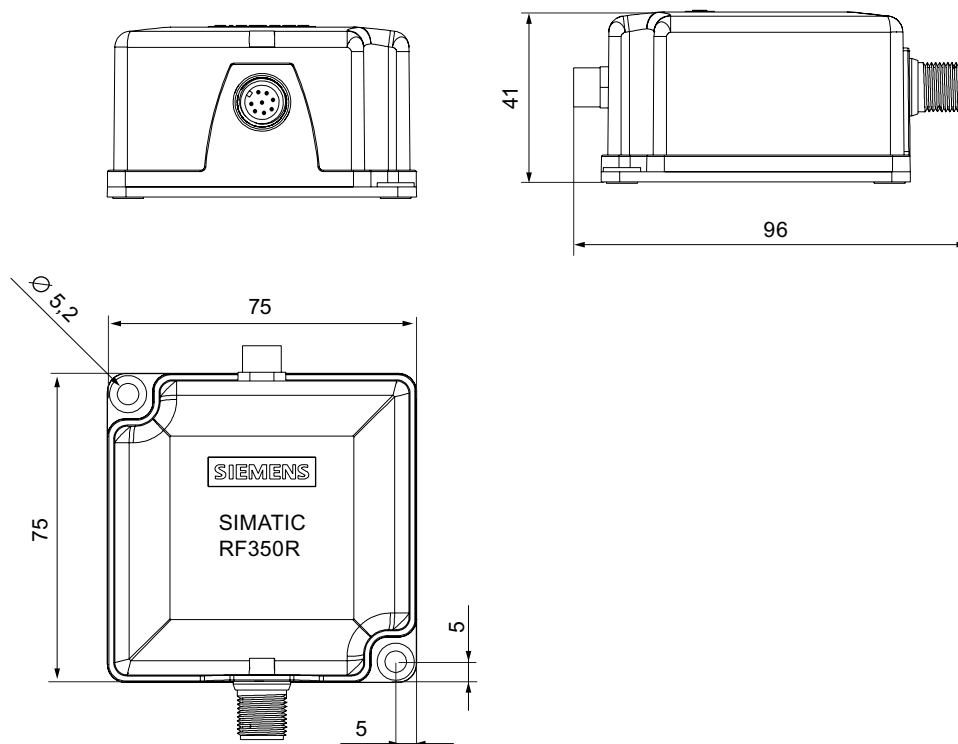





Figure 5-10 RF350R dimension drawing

Dimensions in mm

## 5.5.10 Antennas

### 5.5.10.1 Features

You can use the following plug-in antennas from the MOBY E product spectrum for the RF350R reader:

Antenna	Product photo	Limit distance $S_9$ in mm <sup>1)</sup>	Dimensions (L x B x H) in mm	Suitable for dynamic operation
MOBY E ANT 1		to 60	75 x 75 x 20	Yes
MOBY E ANT 18		to 13	Ø M18 x 50	no
MOBY E ANT 30		to 22	Ø M30 x 58	no

1) depending on the transponder used

#### ANT 1

The ANT 1 is an antenna in the mid performance range and can be used to the customer's advantage in production and assembly lines due to its manageable housing shape. The antenna dimensions make it possible to read/write large quantities of data dynamically from/to the tag during operation. The antenna cable can be connected at the reader end.

#### ANT 18

The ANT 18 is designed for use in small assembly lines. Due to its small, compact construction, the antenna can be easily positioned for any application using two plastic nuts (included in the package). The antenna cable can be connected at the reader end. With the RF320T and RF340T tags, communication with the data storage unit is only possible in static mode.

## **ANT 30**

The ANT 30 is designed for use in small assembly lines. In comparison to ANT 18, the maximum write/read distance is approximately 60 % larger. Due to its compact construction, the antenna can be easily positioned for any application using two plastic nuts (included in the package). The antenna cable can be connected at the reader end. With the RF320T, RF340T and RF350T tags, communication with the data storage unit is only possible in static mode.

### 5.5.10.2 Ensuring reliable data exchange

The "center point" of the transponder must be situated within the transmission window.

### 5.5.10.3 Metal-free area

The antennas ANT1, ANT18 and ANT30 can be flush-mounted on metal. Please allow for a possible reduction in the field data values.

Metal-free area for flush-mounting:

$a = 40 \text{ mm}$

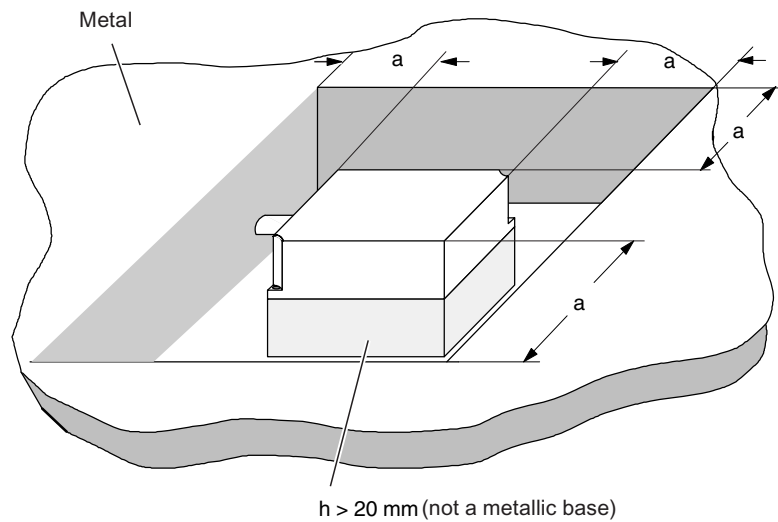
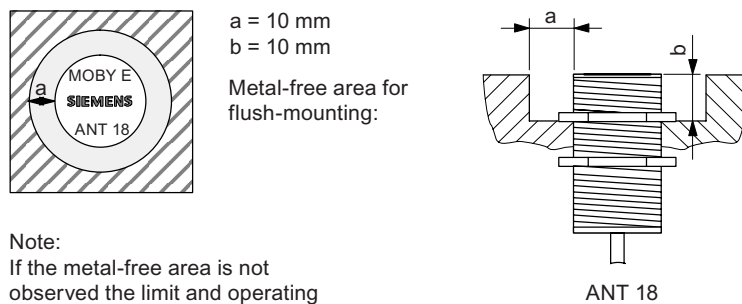

Figure 5-11 Metal-free area for ANT 1



Note:  
If the metal-free area is not observed the limit and operating distances are reduced

Figure 5-12 Metal-free area for ANT 18

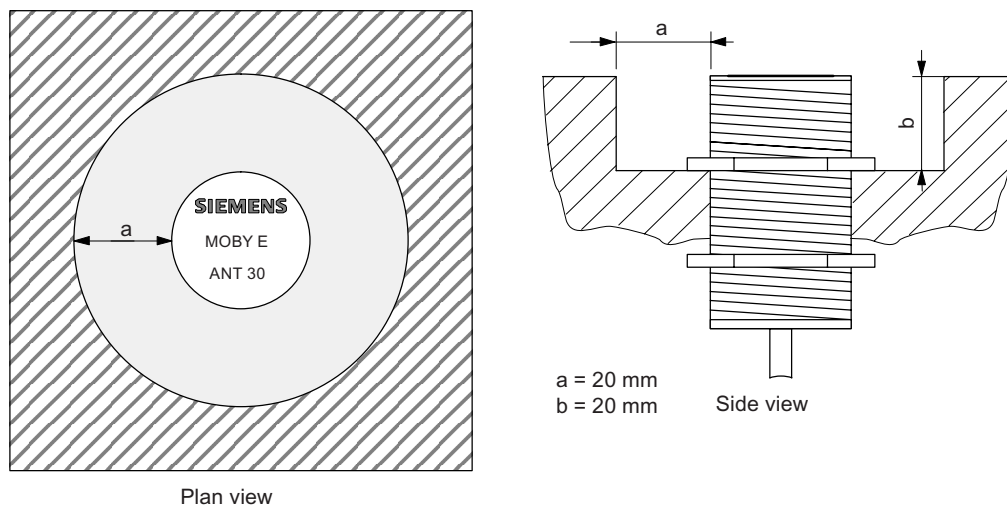

Figure 5-13 Metal-free area for ANT 30

### 5.5.10.4 Minimum distance between antennas

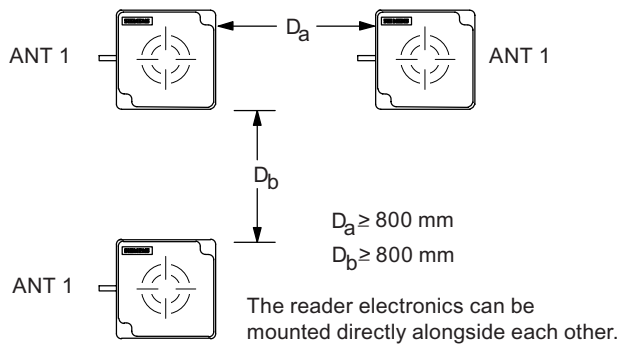

Figure 5-14 Minimum distance for ANT 1

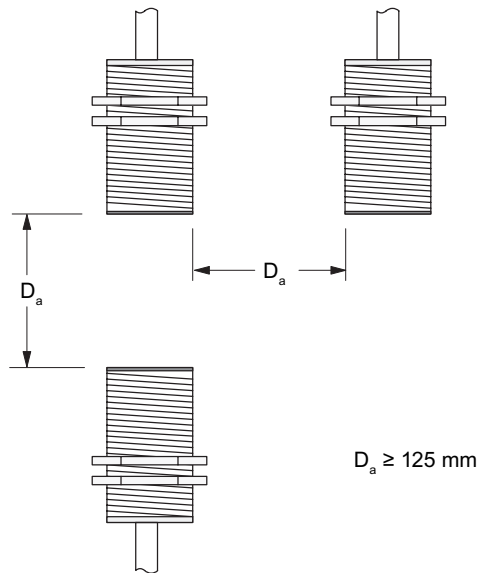

Figure 5-15 Minimum distance for ANT 18

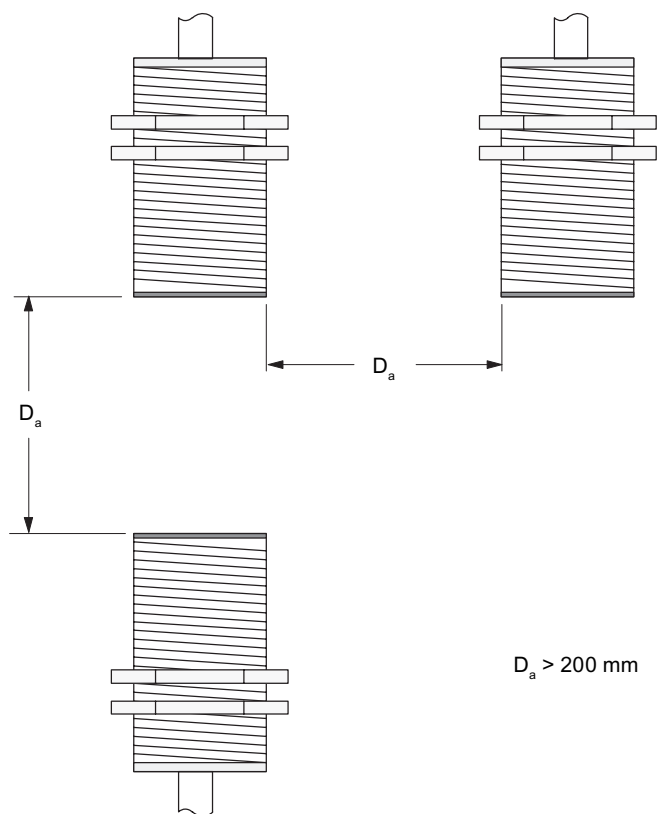

Figure 5-16 Minimum distance for ANT 30

## 5.5.10.5 Technical data for antennas

Table 5-6 Technical data for antennas ANT1, ANT18 and ANT30

Antenna	ANT1	ANT18	ANT30
Read/write distance antenna to transponder (Sg) max	100 mm	15 mm	24 mm
Enclosure dimensions in mm	75 x 75 x 20 (L x W x H)	M18 x 1.0 x 55 (Ø x thread x L)	M30 x 1.5 x 58 (Ø x thread x L)
Color	Anthracite	Pale turquoise	
Material	Plastic PA 12	Plastic Krastin	
Plug connection	4-pin (pins on antenna side)		
Antenna cable lengths	3 m		
Degree of protection according to EN 60529	IP 67	IP 67 (at the front)	
Shock-resistant acc. to EN 60721-3-7, Class 7M2	50 g <sup>1)</sup>		
Vibration-resistant to EN 60721-3-7, Class 7M2	20 g ( 3 to 500 Hz) <sup>1)</sup>		
Attachment of the antenna	2 x M5 screws	2 plastic nuts M18 x 1.0	2 plastic nuts M30 x 1.5
Ambient temperature	<ul style="list-style-type: none"> <li>• During operation                      • -25 °C to +70 °C</li> <li>• Storage and transport                • -40 °C to +85 °C</li> </ul>		
MTBF (at +40 °C)	2,5 x 10 <sup>5</sup> hours		
Approx. weight	80 g	120 g	150 g
1) Warning: The values for shock and vibration are maximum values and must not be applied continuously.			

## 5.5.10.6 Ordering data for antennas

Product description	Order No.
MOBY E, ANT 1	6GT2398-1CB00
MOBY E, ANT 18	6GT2398-1CA00
MOBY E, ANT 30	6GT2398-1CD00



### 5.5.10.7 Dimension drawings for antennas

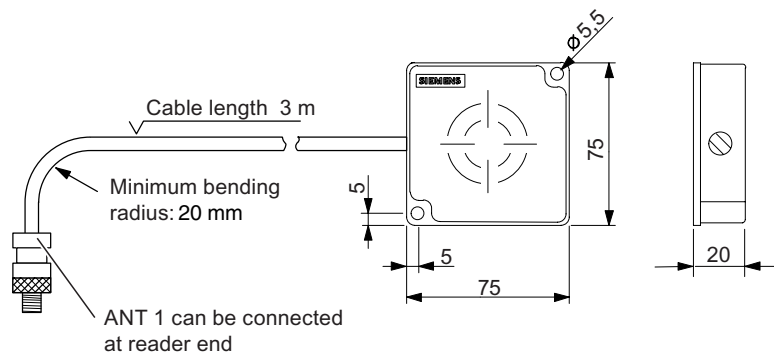

Figure 5-17 Dimension drawing for ANT 1

Dimensions in mm

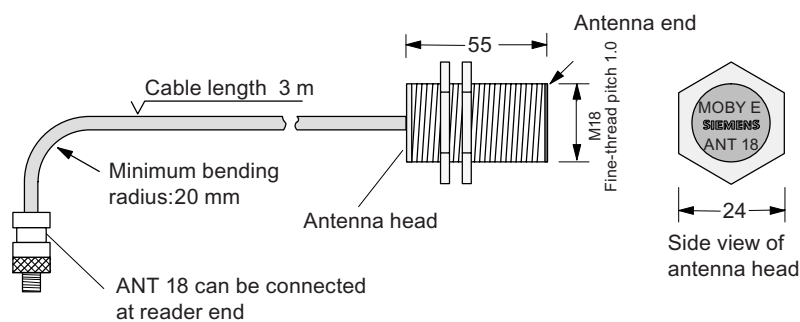

Figure 5-18 Dimension drawing for ANT 18

Dimensions in mm

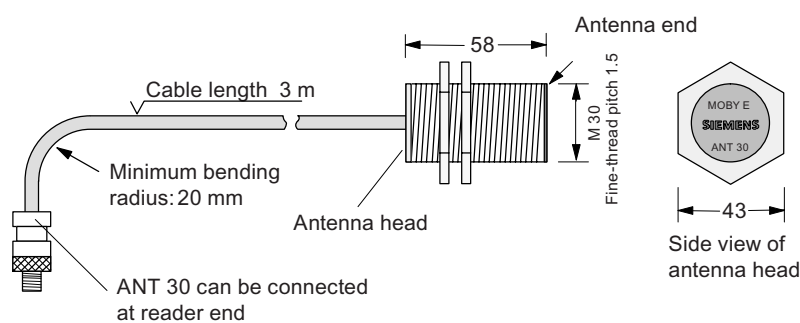



Figure 5-19 Dimension drawing for ANT 30

Dimensions in mm

## 5.6 RF380R

### 5.6.1 Features

Reader RF350R	Features	
	Structure	① RS232 or RS422 interface ② Status display
	Field of application	Identification tasks on assembly lines in harsh industrial environments
	Read/write distance to transponder	Max. 150 mm
	Data transmission rate	<ul style="list-style-type: none"> <li>• Read: approx. 3,100 byte/s</li> <li>• Write: approx. 3,100 byte/s</li> </ul>

### 5.6.2 Pin assignment of RF380R RS232/RS422 interface

You can connect the RF380R reader to a higher-level system via the internal RS422 interface or via the RS232 interface. After connection, the interface module automatically detects which interface has been used.

Note correct assignment of the pins here:

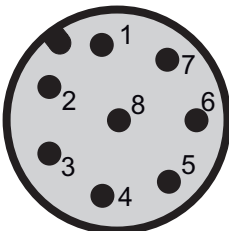
Pin	Pin Device end 8-pin M12	Assignment	
		RS232	RS422
	1	+ 24 V	+ 24 V
	2	RXD	- Transmit
	3	0 V	0 V
	4	TXD	+ Transmit
	5	NC	+ Receive
	6	NC	- Receive
	7	not used	not used
	8	Earth (shield)	Earth (shield)

### 5.6.3 Display elements of the RF380R reader

Color		Meaning
Green	Flashing	Operating voltage present, reader not initialized or antenna switched off
	Permanently on	Operating voltage present, reader initialized and antenna switched on
Yellow <sup>1)</sup>		Transponder present
Flashing red		Error has occurred, the type of flashing corresponds to the error code in the table in Section "Error codes". The optical error display is only reset if the corresponding reset parameter ("option_1", see FC45 / FB45 documentation, Section "Input parameters") is set.

<sup>1)</sup> In the operating state "Without presence", the lighting duration may be very short.

### 5.6.4 Ensuring reliable data exchange

The "center point" of the transponder must be situated within the transmission window.

### 5.6.5 Metal-free area

The RF380R can be flush-mounted in metal. Please allow for a possible reduction in the field data values.

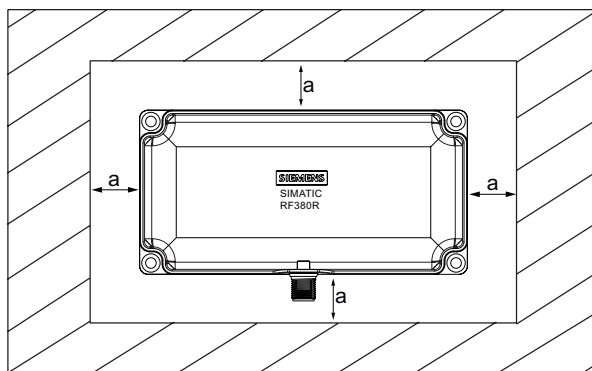

Figure 5-20 Metal-free area for RF380R

To avoid any impact on the field data, the distance  $a$  should be  $\geq 20$  mm.

### 5.6.6 Minimum distance between RF380R readers

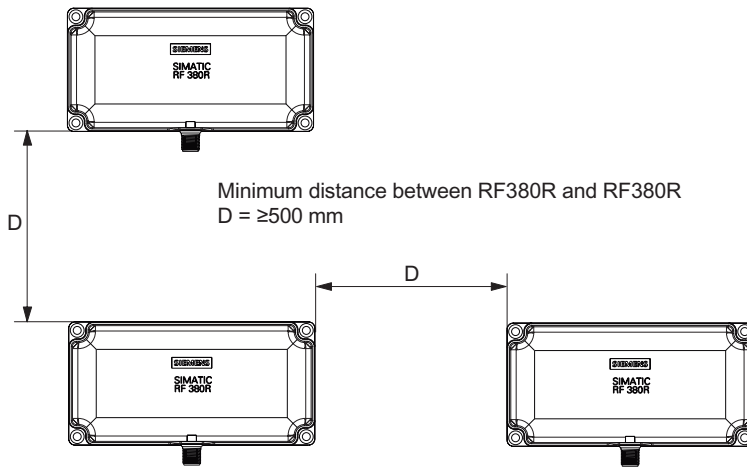

Figure 5-21 Minimum distance between RF380R readers

## 5.6.7 Technical specifications of the RF380R reader

Table 5-7 Technical specifications of the RF380R reader

Inductive interface to the transponder	
Transmission frequency for power/data	13.56 MHz
Antenna	integrated
Interface to communication module	RS232 or RS422 (3964R protocol)
Baud rate	19200 baud, 57600 baud, 115200 baud
Cable length between reader and communication module	RS422 data cable length: max. 100 m RS232 data cable length: Max. 30 m
Read/write distances of reader	See RF380R field data
Minimum distance between two RF380R readers	≥ 500 mm
Maximum data transfer rate reader - transponder (tag)	
Reading	Approx. 3100 byte/s
Writing	Approx. 3100 byte/s
Functions	Initialize/read/write transponder Scan status and diagnostics information Switch antenna on/off Repeat command Scan transponder serial numbers
Voltage supply	24 V DC
Indicators	2-color LED (operating voltage, presence, error)
Connector	M12 (8-pin)
Enclosure	
Dimensions (in mm)	160 x 80 x 40 (without M12 plug connector)
Color	Anthracite
Material	Plastic PA 12
Fixing	4 x M5 screws
Ambient temperature	
during operations	-10 °C to +70 °C
during transport and storage	-40 °C to +85 °C
Degree of protection to EN 60529	IP67
Shock to EN 60 721-3-7 Class 7 M2	50 g
Vibration to EN 60 721-3-7 Class 7 M2	20 g
Weight	Approx. 400 g
MTBF (Mean Time Between Failures) in years	109 years
Approvals	Radio to R&TTE guidelines EN 300 330, EN 301489, CE
Current consumption	typ. 160 mA

5.6.8 FCC information

Siemens SIMATIC RF380R

FCC approval pending

<p>Reader RF380R                  With RS422 interface (3964R)                  IP67;                  -10 °C to +60 C, dimensions 160 x 96 x 40 (L x W x H in mm);                  with integrated antenna;                  max. limit distance 150 mm (depending on transponder)</p>	<p>6GT2801-3AA10</p>
--	----------------------

5.6.10 Dimension drawing

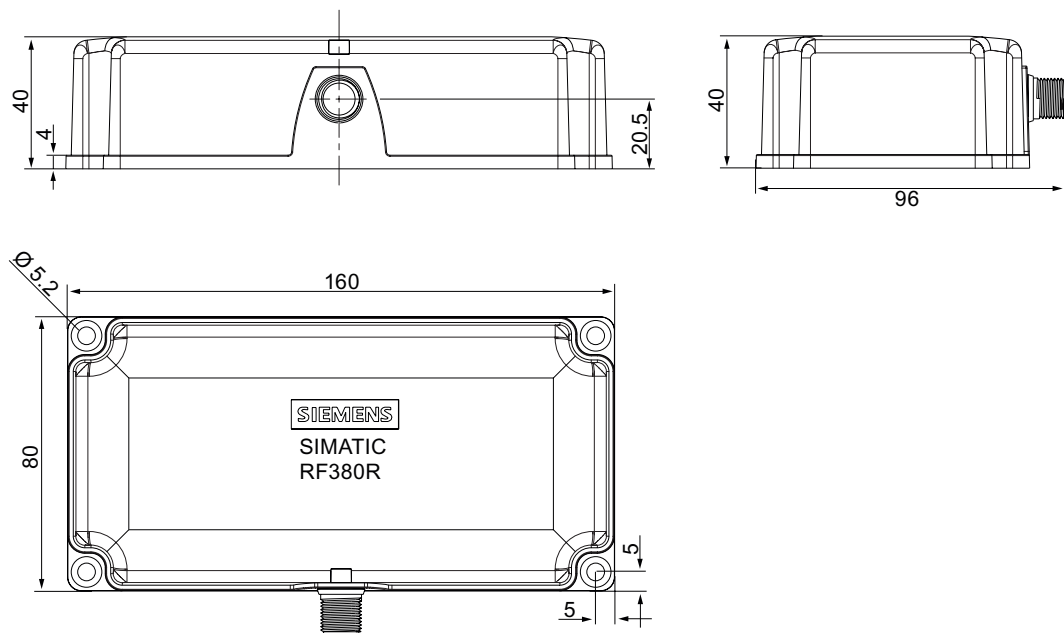

Figure 5-22 Dimension drawing RF380R

Dimensions in mm

# Transponders

## 6.1 Overview

Transponders consist predominantly of logic, FRAM and/or EEPROM.

If a transponder moves into the transmission window of the reader, the necessary power for all of the circuit components is generated and monitored by the power supply unit. The pulse-coded information is prepared in such a way that it can be processed further as pure digital signals. The handling of data, including check routines, is performed by the logic, which also manages the various memories.

## 6.2 RF320T

### 6.2.1 Features

Transponder RF320T	Features	
	Field of application	Identification tasks on small assembly lines in harsh industrial environments
	Memory	Read-only area (4 bytes UID) User data area (20 bytes)
	Read/write range	See Section Field data for transponders, readers and antennas (Page 37)
	Mounting on metal	Not possible Recommended distance from metal $\geq 20$ mm



## 6.2.2 Metal-free area

### Mounting of RF320T on metal

Direct mounting of the RF320T on metal is not allowed.

The following figures show the minimum distance between the RF320T and metal:

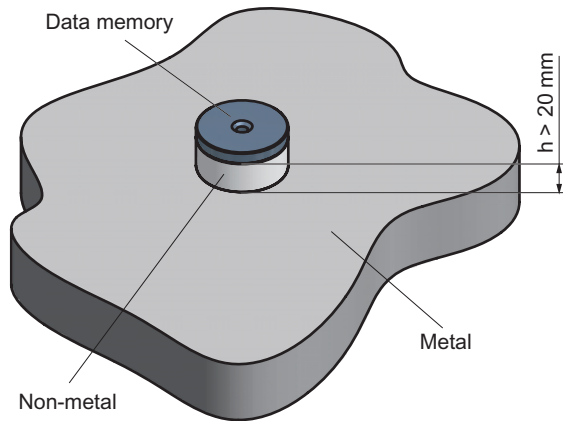

Figure 6-1 Mounting of an RF320T on metal with spacer

### Flush-mounting of RF320T in metal

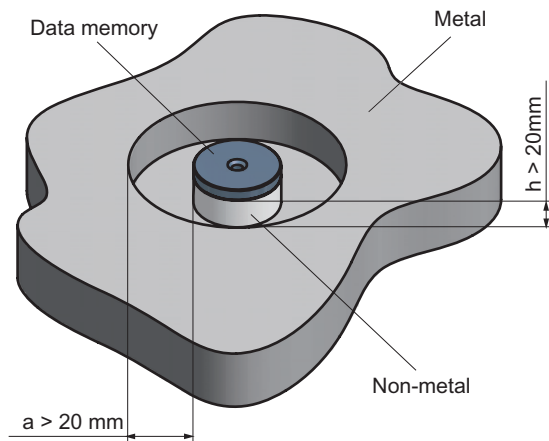

Figure 6-2 Flush-mounting of RF320T in metal with spacer

At lower values, the field data change significantly, resulting in a reduced range.

### 6.2.3 Technical data

Table 6-1 Technical data for RF320T

Memory size	20 bytes EEPROM (r/w), 4 bytes UID (ro)
Memory organization	Byte-oriented access, write protection possible in 4-byte blocks
MTBF (Mean Time Between Failures) in years	1871
Read cycles	Unlimited
Write cycles, min. at ≤ 40 °C, typical	50 000 > 100 000
Data retention time	> 10 years (at < +40 °C)
Write/read distance	dependent on the reader used (see field data)
Energy source	Inductive power transmission
Shock/vibration-resistant to EN 60721-3-7, Class 7 M3	100 g/20 g
Torsion and bending load	not permissible
Fixing	Adhesive/M3 screws
Recommended spacing from metal	> 20 mm
Degree of protection to EN 60529	• IP67/IPX9K
Housing	Button
• Dimensions	• Ø 27 mm x 4 mm
• Color/material	• Black/epoxy resin
Ambient temperature	
• Operation	• -25 to +85 °C
• Transport and storage	• -40 to +125 °C
Weight	Approx. 5 g

**Note**

All the technical data listed are typical data and are applicable for an ambient temperature of between 0 °C and +50 °C and a metal-free environment.

### 6.2.4 Ordering data

<b>Transponder RF320T</b>	<b>Order number:</b>
Transponder RF320T, button, 20 byte EEPROM, IP 67, -25 °C to +85 °C, d = 27 mm x 4 mm	6GT2800-1CA00

### 6.2.5 Dimension drawing

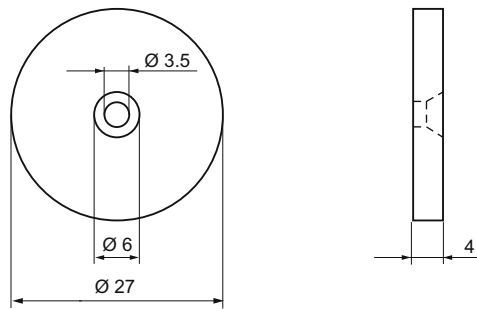



Figure 6-3 RF320T dimension drawing

Dimensions in mm

## 6.3 RF340T

### 6.3.1 Features

Transponder RF340T	Features	
 <p>The image shows a grey, rectangular transponder with a circular antenna on the top right. The text on the device reads: 'SIEMENS B', 'SIMATIC', 'RF 340 T', and '65T2800-4B800'.</p>	Field of application	Identification tasks on small assembly lines in harsh industrial environments
	Memory	Read-only area (4 bytes UID) Read/write memory (8 KB) OTP <sup>1)</sup> memory (20 bytes)
	Read/write range	See Section Field data for transponders, readers and antennas (Page 37)
	Mounting on metal	Direct mounting on metal is possible.

<sup>1)</sup> OTP: One Time Programmable

### 6.3.2 Metal-free area

Direct mounting of the RF340T on metal is permitted.

#### Mounting of RF340T on metal

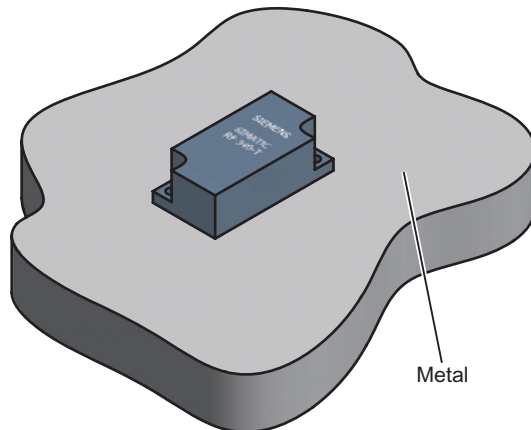

Figure 6-4 Mounting of RF340T on metal

#### Flush-mounting of RF340T in metal:

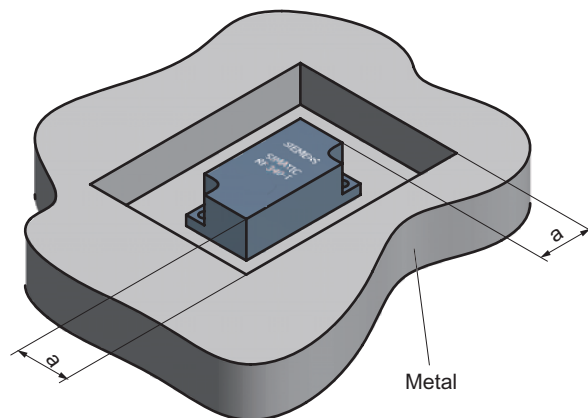

Figure 6-5 Flush-mounting of RF340T in metal

The standard value for  $a$  is  $\geq 20$  mm. At lower values, the field data change significantly, resulting in a reduction in the range.



### 6.3.5 Dimension drawing

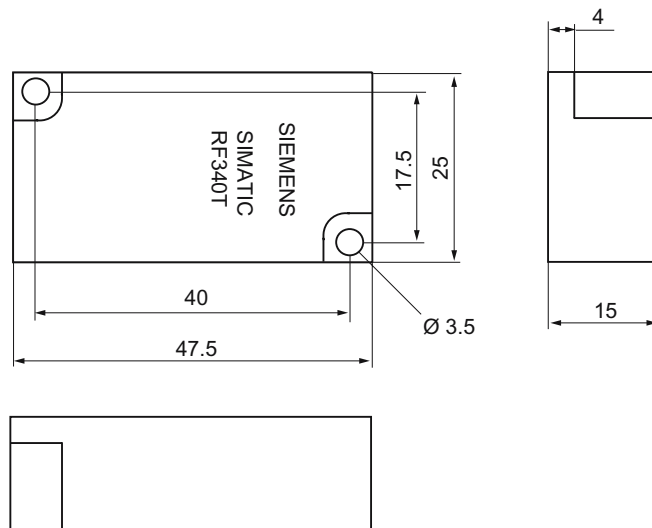



Figure 6-6 RF340T dimension drawing

Dimensions in mm

## 6.4 RF350T

### 6.4.1 Features

Transponder RF350T	Features	
	Field of application	Identification tasks on small assembly lines in harsh industrial environments
	Memory	Read-only area (4 bytes UID) Read/write memory (32 KB) OTP <sup>1)</sup> memory (20 bytes)
	Read/write range	See Section Field data for transponders, readers and antennas (Page 37)
	Mounting on metal	Direct mounting on metal is possible.

<sup>1)</sup> OTP: One Time Programmable



## 6.4.2 Metal-free area

Direct mounting of the RF350T on metal is permitted.

### Mounting of RF350T on metal

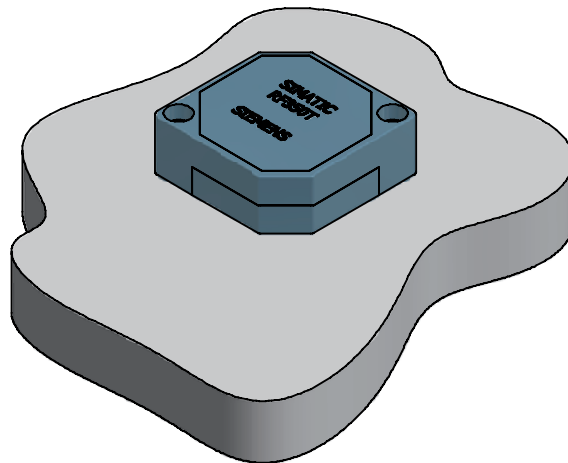

Figure 6-7 Mounting of RF350T on metal

### Flush-mounting of RF350T in metal:

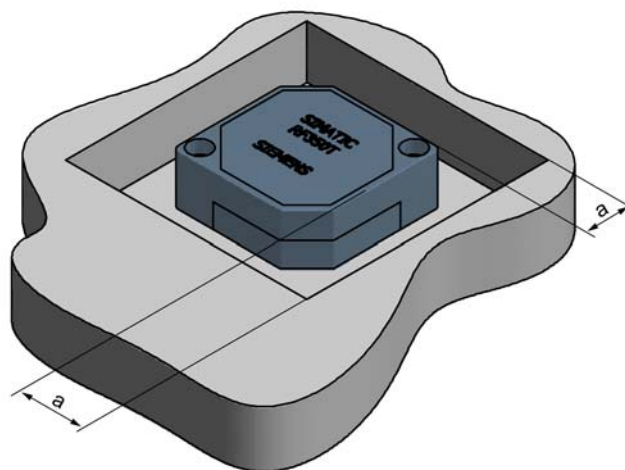

Figure 6-8 RF350T flush-mounted in metal

The standard value for  $a$  is  $\geq 20$  mm. At lower values, the field data change significantly, resulting in a reduction in the range.

### 6.4.3 Technical data

Table 6-3 Technical specifications for RF350T

Memory size	32 KB
Memory organization	Blocks of 8 bits / 1 byte
Memory configuration	<ul style="list-style-type: none"> <li>• Serial number (UID) <span style="float: right;">• 4-byte (fixed code)</span></li> <li>• Application memory <span style="float: right;">• 32765 bytes r/w</span></li> <li>• OTP <sup>1)</sup> memory <span style="float: right;">• 20 bytes</span></li> </ul>
Storage technology	FRAM / EEPROM
MTBF (Mean Time Between Failures) in years	1201
Write cycles, at +40°C	Virtually unlimited (>10 <sup>10</sup> )
Read cycles	Virtually unlimited (>10 <sup>10</sup> )
Transmission rate	with RS422 reader:      with IQ-Sense reader:
• Reading	Approx. 0.3 ms / byte      Approx. 20 ms / byte
• Writing	approx. 0.3 ms / byte      approx. 25 ms / byte
Data retention	> 10 years
Read/write distance	dependent on the reader used (see field data)
Multitag capability	max. 4 transponders
Recommended spacing from metal	can be directly mounted on metal
Power supply	Inductive, without battery
Degree of protection to EN 60529	IP68
Shock to EN 60721-3-7	50 g
Vibration to EN 60721-3-7	20 g
Torsion and bending load	Not permitted permanently
Enclosure dimensions	50 x 50 x 20 mm (L x W x H)
Color	Anthracite
Material	PA12
Fixing	2 screws M4
Ambient temperature	
• During operation	-25 °C to +85 °C
• During transport and storage	-40 °C to +85 °C
Weight	Approx. 25 g

<sup>1)</sup> OTP: (One Time Programmable)

### 6.4.4 Ordering data

<b>RF350T</b>	<b>Order number:</b>
32 KB FRAM (read/write) + 4 byte EEPROM (read only), IP 68, -25 °C to +85 °C, dimensions 50 x 50 x 20 (LxWxH in mm)	6GT2800-5BD00

### 6.4.5 Dimension drawing

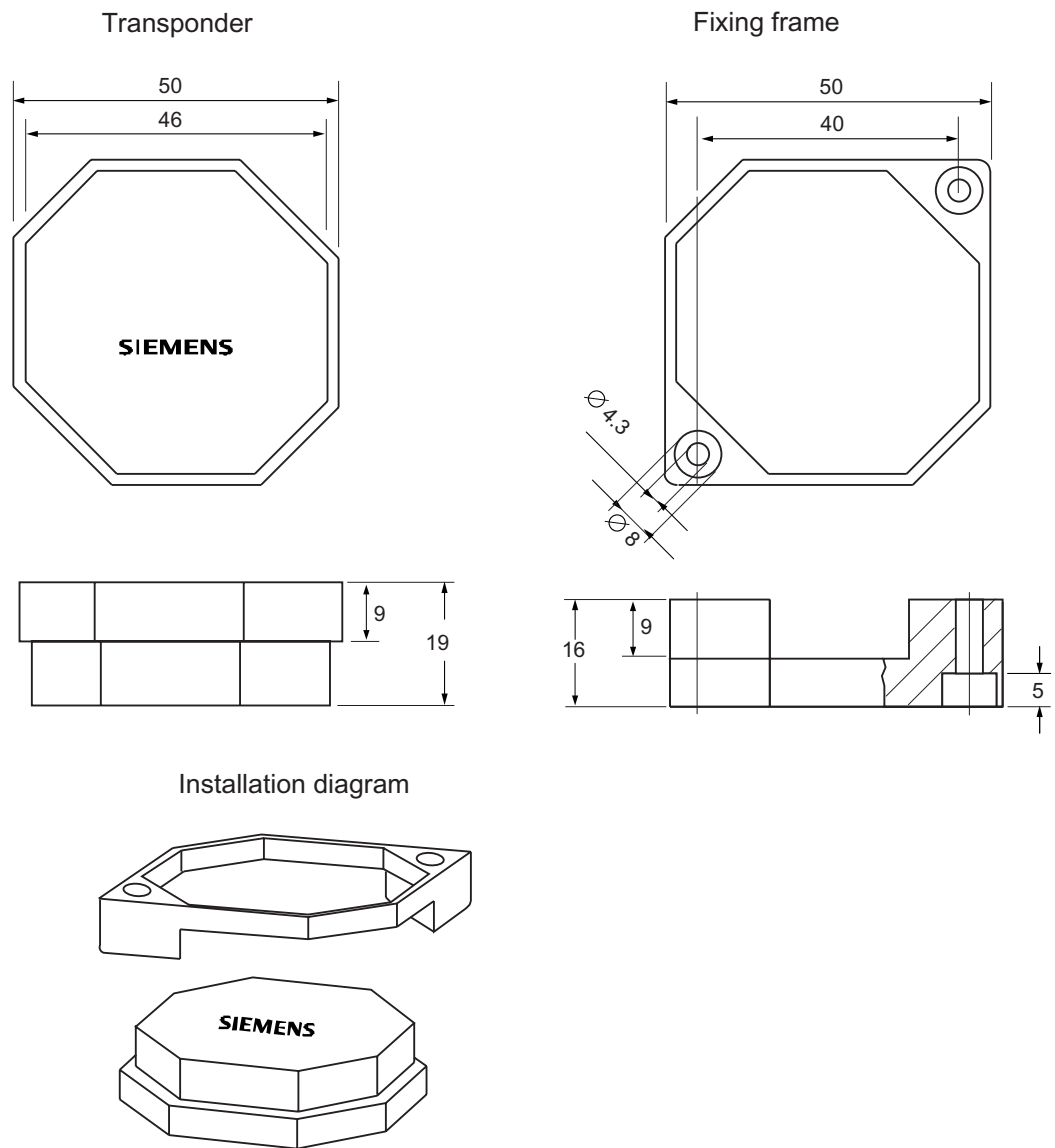

The transponder can be mounted as shown with the fixing frame.

Figure 6-9 RF350T dimension drawing

Dimensions in mm

## 6.5 RF360T

### 6.5.1 Features

Transponder RF360T	Features	
 <p>The image shows a dark grey rectangular transponder with a blue Siemens logo at the top. Below the logo, the text 'SIMATIC RF360T' is printed in white, followed by the part number '6GT2800-4AC00' in a smaller font. Two small white circular marks are visible on the surface.</p>	Area of application	Identification tasks on small assembly lines in harsh industrial environments
	Memory	Read-only area (4 bytes UID) Read/write memory (8 KB) OTP <sup>1)</sup> memory (20 bytes)
	Read/write range	Refer to SectionField data for transponders, readers and antennas (Page 37)
	Mounting on metal	Not possible; recommended distance from metal $\geq 20$ mm

<sup>1)</sup> OTP: One Time Programmable

## 6.5.2 Metal-free area

Direct mounting of the RF360T on metal is not allowed. A distance  $\geq 20$  mm is recommended. This can be achieved using the spacer 6GT2190-0AA00 in combination with the fixing pocket 6GT2190-0AB00.

### Mounting of RF360T on metal

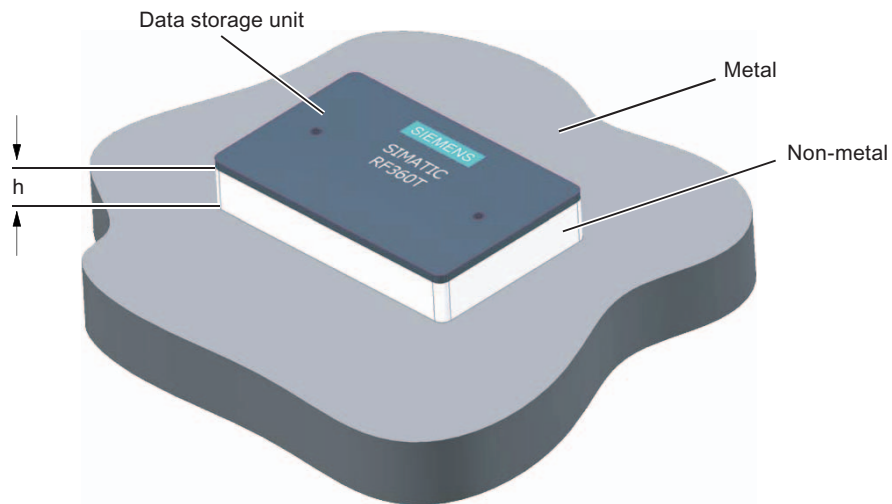

Figure 6-10 Mounting of RF360T with spacer

The standard value for  $h$  is  $\geq 20$  mm.

### Flush-mounting of RF360T in metal:

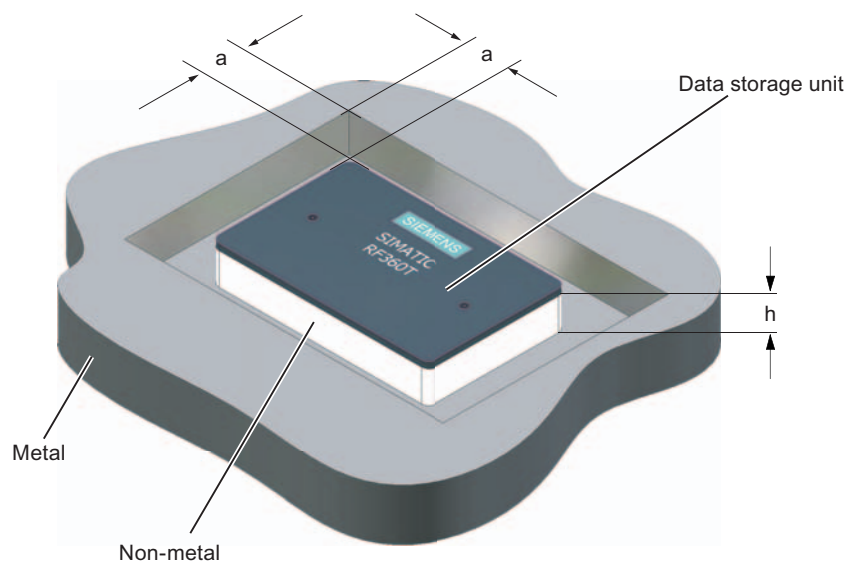

Figure 6-11 Flush-mounting of RF360T with spacer

The standard value for  $a$  is  $\geq 20$  mm. At lower values, the field data change significantly, resulting in a reduction in the range.

**Dimensions of spacer and fixing pocket for RF360T**

Dimension sketch

Spacer: 6GT2190-0AA00

Fixing pocket: 6GT2190-0AB00

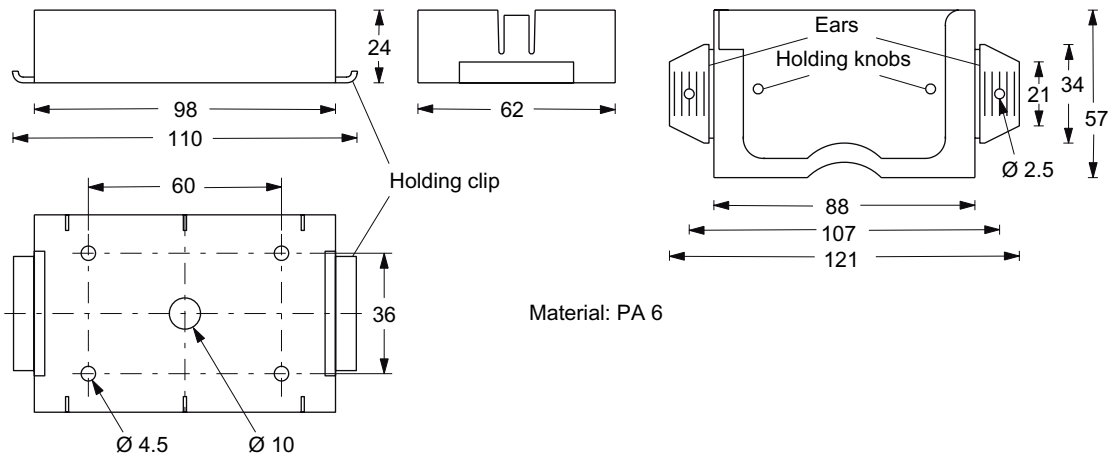

The spacer can be directly mounted on metal. In combination with the fixing pocket, a non-metal distance of 20 mm results between the transponder and metal.

Mounting:

- With 2 or 4 screws (M4)
- With rubbers on the holding clips (e.g. on mesh boxes)
- With cable ties on the holding clips (e.g. on mesh boxes)

Transponder with fixing pocket

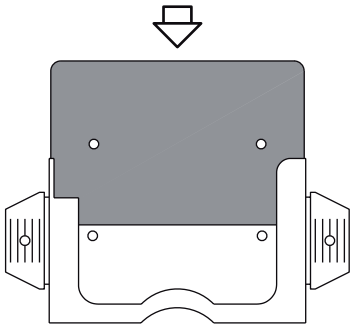

The transponder is inserted into the fixing pocket. Locking is via the holding knobs in the fixing pocket.

Transponder with fixing pocket and spacer (connected together)

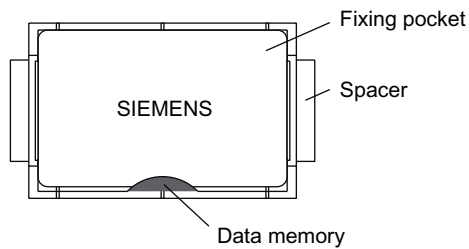

The fixing pocket is attached to a non-metal base by the ears. This can be achieved with:

- Screws in the holes provided
- Rivets in the holes provided
- Nails through the holes
- Tacks through the plastic of the ears
- Pushing into the spacers

The ears can be moved through up to 90°.

**Re-assembly instructions:**

The transponder is inserted into the fixing pocket. The ears are moved by 90° and inserted into the spacer. The fixing pocket must be aligned such that it covers the transponder (see Figure). Locking is automatic.

Figure 6-12 Dimensions of spacer and fixing pocket for RF360T

### 6.5.3 Technical data

Table 6-4 Technical specifications for RF360T

Memory size	8 KB
Memory organization	Blocks of 8 bits / 1 byte
Memory configuration	
<ul style="list-style-type: none"> <li>• Serial number (UID)</li> <li>• Application memory</li> <li>• OTP <sup>1)</sup> memory</li> </ul>	<ul style="list-style-type: none"> <li>• 4-byte (fixed code)</li> <li>• 8189 bytes r/w</li> <li>• 20 bytes</li> </ul>
Storage technology	FRAM / EEPROM
MTBF (Mean Time Between Failures) in years	1201
Write cycles, at +40°C	Virtually unlimited (>10 <sup>10</sup> )
Read cycles	Virtually unlimited (>10 <sup>10</sup> )
Transmission rate	with RS422 reader:      with IQ-Sense reader:
<ul style="list-style-type: none"> <li>• Reading</li> <li>• Writing</li> </ul>	Approx. 0.3 ms / byte      Approx. 20 ms / byte approx. 0.3 ms / byte      approx. 25 ms / byte
Data retention	> 10 years
Read/write distance	dependent on the reader used (see field data)
Multitag capability	max. 4 transponders
Recommended spacing from metal	≥ 20 mm; e.g. using spacer 6GT2190-0AA00 in conjunction with fixing pocket 6GT2190-0AB00
Power supply	Inductive, without battery
Degree of protection to EN 60529	IP67
Shock to EN 60721-3-7	50 g
Vibration to EN 60721-3-7	20 g
Torsion and bending load	Not permitted permanently
Enclosure dimensions	85.8 x 54.8 x 2.5 mm (L x W x H)
Color	Anthracite
Material	PA12
Fixing	2 screws (M3) or with fixing pocket 6GT2190-0AB00
Ambient temperature	
<ul style="list-style-type: none"> <li>• During operation</li> <li>• During transport and storage</li> </ul>	-25°C to +75°C -40°C to +85°C
Weight	Approx. 25 g

<sup>1)</sup> OTP: (One Time Programmable)

### 6.5.4 Ordering data

RF360T	Order number
8 KB FRAM (read/write) + 4 byte EEPROM (read only), IP 67, -25 °C to +75 °C, dimensions 85.8 x 54.8 x 2.5 (LxWxH in mm)	6GT2800-4AC00

### 6.5.5 Dimension drawing

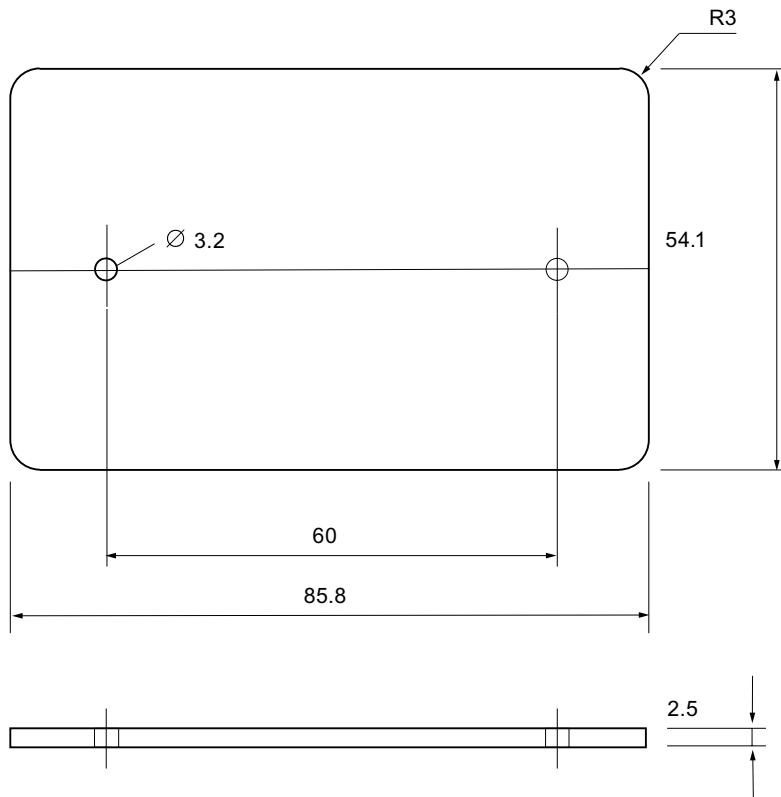

Figure 6-13 RF360T dimension drawing

Dimensions in mm



## 6.6 RF370T

### 6.6.1 Features

The SIMATIC RF370T transponder is a passive (i.e. battery-free) data carrier in a square type of construction.

SIMATIC RF370T transponder	Features	
	Area of application	Identification tasks on assembly lines in harsh industrial environments, suitable for larger ranges, e.g. automotive industry
	Memory	Read-only area: 4 byte UID write/read memory: 32/64 KB OTP <sup>1)</sup> memory: 20 bytes
	Write/read range	Refer to SectionField data for transponders, readers and antennas (Page 37)
	Assembly	Direct assembly on metal or flush-mounting is possible (with two M5 screws)
	Degree of protection	IP68 IPx9K
	High resistance	to mineral oils, lubricants and cleaning agents

<sup>1)</sup> OTP: One Time Programmable; single write

### 6.6.2 Metal-free area

Direct mounting of the RF370T on metal is permitted.

#### Mounting of RF370T on metal

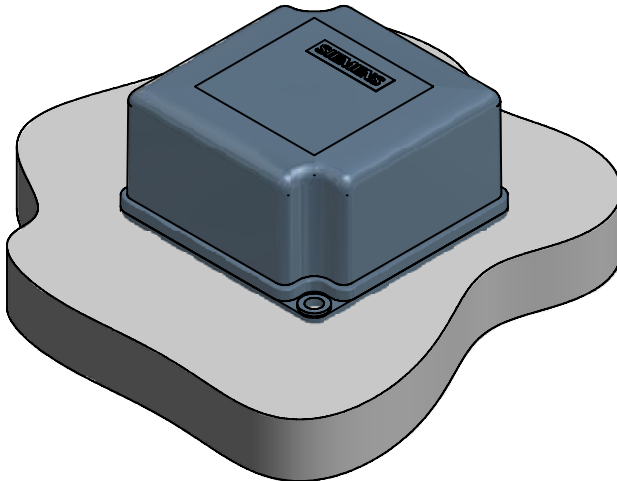

Figure 6-14 Mounting of RF370T on metal

#### Flush-mounting of RF370T in metal:

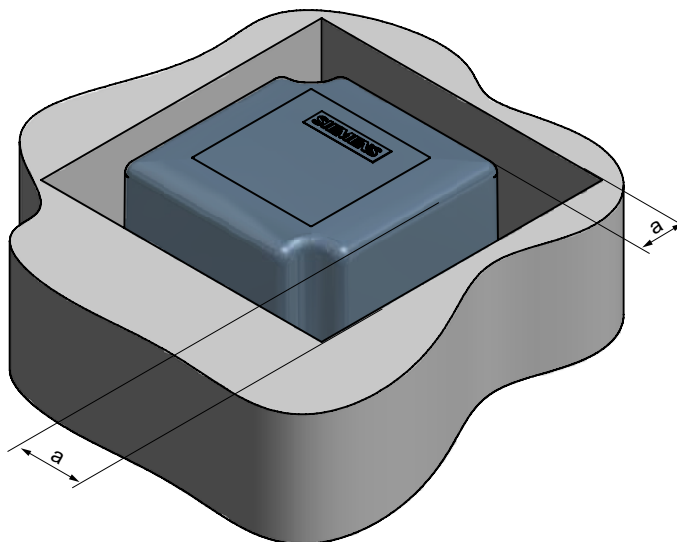

Figure 6-15 RF370T flush-mounted in metal

The standard value for  $a$  is  $\geq 20$  mm. At lower values, the field data change significantly, resulting in a reduction in the range.

### 6.6.3 Mounting instructions

It is essential that you observe the instructions in the Section Installation guidelines (Page 54).

Properties	Description
Type of installation	Screw fixing (two M5 screws)
Tightening torque	< 1.2 Nm (at room temperature)

## 6.6.4 Technical specifications

### 6.6.4.1 Technical data for RF370T with 32 KB FRAM

Table 6-5 Technical specifications for RF370T with 32 KB FRAM

Characteristic	Description	
Memory size	32KB	
Memory organization	Blocks of 8 bits / 1 byte	
Memory configuration	Serial number	4-byte (fixed code)
	Application memory	32765 bytes r/w
	OTP <sup>1)</sup> memory	20 bytes
Storage technology	FRAM / EEPROM	
MTBF (Mean Time Between Failures) in years	1189	
Write cycles, at +40°C	Virtually unlimited (>10 <sup>10</sup> )	
Read cycles	Practically unlimited (>10 <sup>10</sup> )	
Transmission rate	Read	approx. 0.3 ms/byte
	Write	approx. 0.3 ms/byte
Data retention in years	> 10	
Read/write distance	dependent on the reader used (see field data)	
Multitag capability	max. 4 transponders	
Recommended spacing from metal	can be directly mounted on metal	
Power supply	Inductive, without battery	
Degree of protection to EN 60529	IPx9K	
Shock resistant to EN 60721-3-7	50 g	
Vibration resistant to EN 60721-3-7	20 g	
Torsion and bending load	Not permissible continuously	
Housing dimensions	75 x 75 x 40 mm (L x W x H)	
Color	Anthracite	
Material	PA12	
Fixing	Two M5 screws	
Ambient temperature	During operation	-25 °C to +85 °C
	During transport and storage	-40°C to +85°C
Weight	Approx. 200 g	

<sup>1)</sup> OTP: One Time Programmable

## 6.6.4.2 Technical data for RF370T with 64 KB FRAM

Table 6-6 Technical specifications for RF370T with 64 KB FRAM

Characteristic	Description	
Memory size	64 KB	
Memory organization	Blocks of 8 bits / 1 byte	
Memory configuration	Serial number	4-byte (fixed code)
	Application memory	65276 bytes r/w
	OTP <sup>1)</sup> memory	20 bytes
Storage technology	FRAM / EEPROM	
MTBF (Mean Time Between Failures) in years	1189	
Write cycles, at +40°C	Practically unlimited (>10 <sup>10</sup> )	
Read cycles	Practically unlimited (>10 <sup>10</sup> )	
Transmission rate	Read	approx. 0.3 ms/byte
	Write	approx. 0.3 ms/byte
Data retention in years	> 10	
Read/write distance	dependent on the reader used (see field data)	
Multitag capability	max. 4 transponders	
Recommended spacing from metal	Can be directly mounted on metal	
Power supply	Inductive, without battery	
Degree of protection to EN 60529	IPx9K	
Shock resistant to EN 60721-3-7	50 g	
Vibration resistant to EN 60721-3-7	20 g	
Torsion and bending load	Not permissible continuously	
Housing dimensions	75 x 75 x 40 mm (L x W x H)	
Color	Anthracite	
Material	PA12	
Fixing	Two M5 screws	
Ambient temperature	During operation	-25 °C to +85 °C
	During transport and storage	-40°C to +85°C
Weight	Approx. 200 g	

<sup>1)</sup> OTP: One Time Programmable

### 6.6.5 Ordering data

Ordering data	Order Number
SIMATIC RF300 RF370T transponder 32 KB FRAM, -25 to +85 degrees C, IP68; 75 x 75 x 40 mm	6GT2800-5BE00
SIMATIC RF300 RF370T transponder 64 KB FRAM, -25 to +85 degrees C, IP68; 75 x 75 x 40 mm	6GT2800-6BE00

### 6.6.6 Dimensional drawing

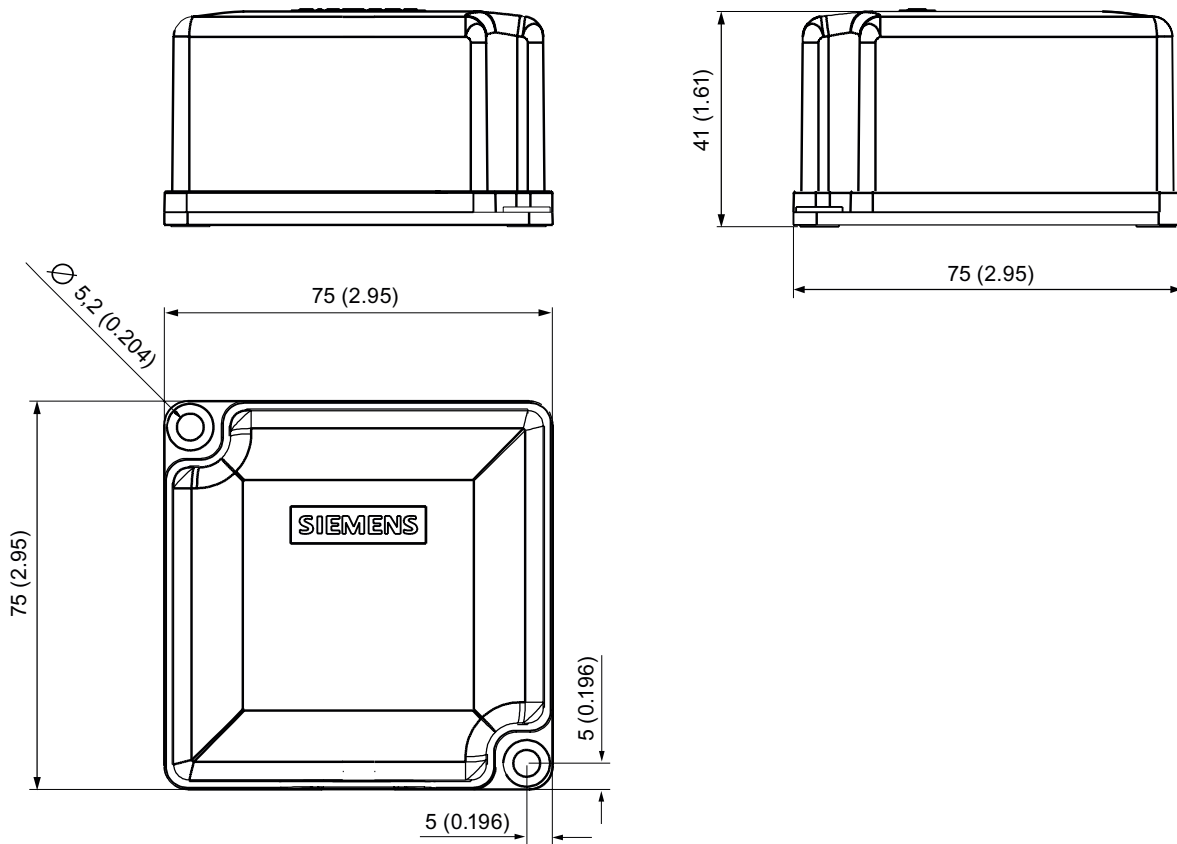



Figure 6-16 RF370T dimension drawing

Dimensions in mm (inches in brackets)

## 6.7 RF380T

### 6.7.1 Features

The SIMATIC RF380T transponder is an extremely rugged and heat-resistant round data carrier suitable e.g. for applications in the automotive industry.

SIMATIC RF380T transponder	Features	
	Area of application	Identification tasks in applications (e.g. automotive industry) with cyclic <b>high temperature stress</b> > 85 °C and < 220 °C Typical applications: <ul style="list-style-type: none"> <li>• Primer coat, electrolytic dip area, cataphoresis with the associated drying furnaces</li> <li>• Top coat area with drying furnaces</li> <li>• Washing areas at temperatures &gt; 85°C</li> <li>• Other applications with higher temperatures</li> </ul>
	Memory	<ul style="list-style-type: none"> <li>• Read-only area (4 bytes UID)</li> <li>• Read/write memory (32 KB)</li> <li>• OTP <sup>1)</sup> memory (20 bytes)</li> </ul>
	Write/read range	Refer to SectionField data for transponders, readers and antennas (Page 37)
	Assembly	<ul style="list-style-type: none"> <li>• Direct assembly on metal or flush-mounting is possible.</li> <li>• The transponder can be secured using a special holder (see installation guidelines, section on RF380T). The tag size is designed such that it can be secured on a skid or also directly on a body.</li> </ul>
	Degree of protection	IP 68
	High resistance	to mineral oils, lubricants and cleaning agents
	1) OTP: One Time Programmable	



## 6.7.2 Installation guidelines for RF380T

It is essential that you observe the instructions in the Section Installation guidelines (Page 54).

The following section only deals with features specific to the SIMATIC RF380T.

### 6.7.2.1 Mounting instructions

#### CAUTION

You are strongly recommended to only use the tag with the original holder specified. Only this holder guarantees that the data memory observes the listed values for shock, vibration and temperature. A protective cover is recommendable for applications in paint shops.

### Data memory support

Short version (6GT2 090-0QA00)	Long version (6GT2090-0QA00-0AX3)
<p>Dimensions in mm, inches in brackets</p>	<p>Dimensions in mm, inches in brackets</p>
<p>Material: V2A sheet-steel with thickness 2.5 mm BI 2.5 DIN 59382 1.4541</p>	

### Assembly of data memory with support

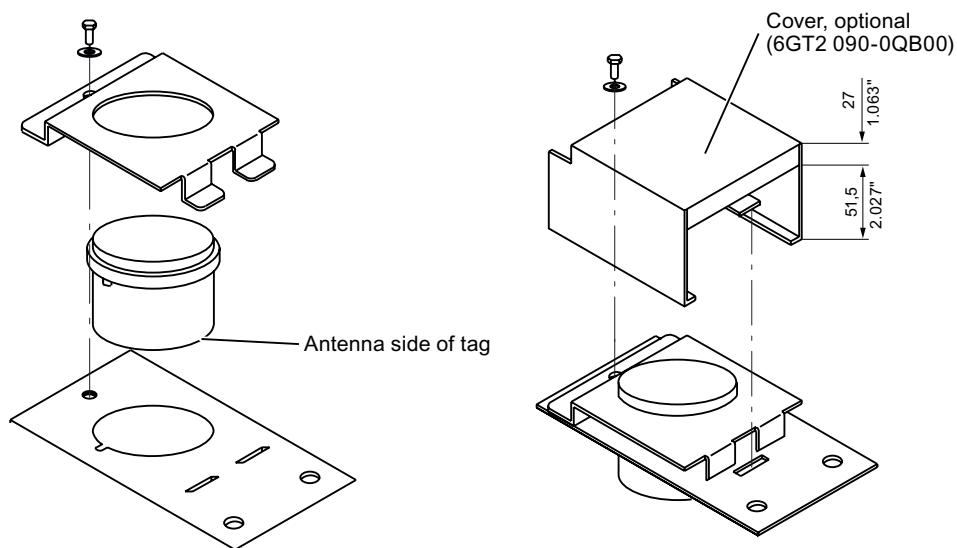

Figure 6-17 Assembly of tag with support

### Scope of supply

The support is provided with all mounting parts and a mounting diagram. Mounting screws for securing the support are not included. The mounting screws are of diameter M 10. The minimum length is 25 mm. The optional cover can be used for the long and short versions of the support.