

Table of contents

1.1	RF620R reader	7
1.1.1	Description	7
1.1.1.1	Ordering data	8
1.1.1.2	Status display	9
1.1.1.3	Pin assignment of the RS422 interface	10
1.1.1.4	Pin assignment of the connecting cable	10
1.1.1.5	Grounding connection	11
1.1.2	Planning application	11
1.1.2.1	Minimum mounting clearances of two readers	11
1.1.2.2	Antenna diagram for RF620R (ETSI)	12
1.1.2.3	Antenna/read point configurations	15
1.1.3	Installing/Mounting	15
1.1.4	Configuration/integration	16
1.1.4.1	Transmission protocols	17
1.1.5	Technical data	17
1.1.5.1	Mechanical data	17
1.1.5.2	Technical data according to EPC and ISO	18
1.1.5.3	Maximum number of readable tags	19
1.1.6	Dimension drawings	20
1.1.7	Certificates and approvals	20
	21	
1.2.1	Description	22
1.2.1.1	Ordering data	23
1.2.1.2	Status display	24
1.2.1.3	Pin assignment of the RS422 interface	25
1.2.1.4	Pin assignment of the connecting cable	25
1.2.1.5	Grounding connection	26
1.2.2	Planning application	26
1.2.2.1	Minimum mounting clearances of two antennas of different readers	26
1.2.2.2	Antenna/read point configurations	27
1.2.3	Installing/Mounting	27
1.2.4	Configuration/integration	28
1.2.4.1	Configuration	28
1.2.4.2	Transmission protocols	29
1.2.5	Technical data	29
1.2.5.1	Mechanical data	29
1.2.5.2	Technical data according to EPC and ISO	30
1.2.5.3	Maximum number of readable tags	31
1.2.6	Dimension drawings	32
1.2.7	Certificates and approvals	32

Readers

1.1 RF620R reader

1.1.1 Description

The SIMATIC RF620R is an active stationary reader in the UHF frequency range with an integrated circular polarized antenna.

The SIMATIC RF620R is connected to a SIMATIC S7 controller via an ASM interface module. The degree of protection corresponds to IP 65.

	Item	Description
	(1)	LED operating indicator
	(2)	RS 422 interface (8-pin M12 socket)

Highlights

- The tags are read in accordance with the requirements of the EPCglobal Class 1, Gen 2 and ISO/IEC 18000-6C standards
- Supports low-cost SmartLabels as well as reusable, rugged data media
- High reading speed: Depending on the function block (multitag mode), many tags can be detected simultaneously (bulk reading), rapidly moving tags are reliably acquired.
- The RF620R (ETSI) "6GT2811-5BA00-0AA0" is suitable for the frequency band 865 to 868 MHz UHF (EU, EFTA, Turkey).
- IP65 degree of protection for reader
- Can be used for a high temperature range
- Dense Reader Mode (DRM) for environments in which many readers are operated in close proximity to each other
- TIA system interface:
 - RS 422

1.1.1.1 Ordering data

Device	Order No.
RF620R (ETSI) reader basic unit for EU, EFTA, Turkey	6GT2811-5BA00-0AA0

Accessories	Description	Order No.
Connecting cable	RS 422, M12 plug, 8-pin socket: 2 m	6GT289-0FH20
	RS 422, M12 plug, 8-pin socket: 5 m	6GT289-0FH50
	RS 422, M12 plug, 8-pin socket: 10 m	6GT289-0FN10
	RS 422, M12 plug, 8-pin socket: 20 m	6GT289-0FN20
	RS 422, M12 plug, 8-pin socket: 50 m	6GT289-0FN50
Antenna mounting kit	Standard	6GT2890-0AA00
Software & Documentation	CD-ROM	6GT2080-2AA10

1.1.1.2 Status display

The device is equipped with a three colored LED. The LED can be lit in green, red or yellow. The meaning of the indication changes in accordance with the color and state (on, off, flashing) of the LED:

Green LED	Red LED	Yellow LED	Meaning
Off	Off	Off	The device is starting up.
Flashing	Off	Off	The device is ready. The antenna is switched off.
On	Off	Off	The device is ready. The antenna is switched on.
Off	Off	On	"With presence": At least one tag is in the field. "Without presence": Communication with a tag is active.
Off	Flashing	Off	Reader is not active, a serious error has occurred. In addition, this LED also indicates the fault status through the number of flashing pulses. Reboot (operating voltage Off → On is necessary). The LED flashes once for the 'INACTIVE' status, rebooting is not necessary in this case.

For more detailed information on the flash codes of the reader see Chapter Error messages and flash codes for RF620R/RF630R (Page **Fehler! Textmarke nicht definiert.**)

Note

LED not lit yellow?

If the LED does not light up yellow even though a tag is located within the field, common causes are:

- Incorrect configuration in the init_run command, or init_run command was not executed (see "Configuration Manual RF620R/RF630R")
- Antenna is switched off
- A tag is used, that is not compatible with the reader protocol (EPC Global Class 1 Gen 2).
- Tag is defective
- Reader or antenna has a defect
- Tag is not in the field of radiation of the transmit antenna

1.1.1.3 Pin assignment of the RS422 interface

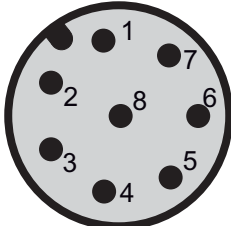
Pin	Pin Device end 8-pin M12	Assignment
	1	+ 24 V
	2	- Transmit
	3	0 V
	4	+ Transmit
	5	+ Receive
	6	- Receive
	7	Free
	8	Earth (shield)

The knurled bolt of the M12 plug is not connected to the shield (on the reader side).

Note

You must therefore not use any SIMATIC connecting cables that use the angled M12 plug.

1.1.1.4 Pin assignment of the connecting cable

Table 1- 1 RS 422 - on reader side

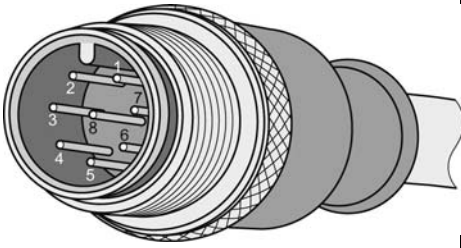
M12 pin	Core color	Pin assignment	View of M12 connector
1	white	24 V DC	
2	brown	TX neg	
3	green	GND	
4	yellow	TX pos	
5	Gray	RX pos	
6	pink	RX neg	
7	blue	Not used	
8	red	Earth (shield)	

Note

This cable has an 8-pin M12 connector at one end and the other cable end is 'open'. There are 8 color-coded single cores there for connecting to external devices. There are different cable lengths in the product range (3 m to 50 m). Long cables can be reduced if necessary.

Note

For long cables: Adapt supply voltage and data rate accordingly

Note that with long cables in particular, the supply voltage of 24 V DC must always be applied. Note also that the data rate on the serial interface must, if necessary, be reduced. (See "Configuration Manual RF620R/RF630R")

1.1.1.5 Grounding connection

The RF620R/RF630R can be electrically connected to the ground potential through a contact washer. The tightening torque must be increased in this case to ensure that electrical contact is made (2.7 Nm).

Ground connection	
	(a) Hexagon-head screw
	(b) Plain washer
	(c) Cable lugs
	(d) Contact washer: Use contact washers according to the Siemens standard SN 70093-6-FSt-flNnnc-480h for ground connection, Siemens item No.: H70093-A60-Z3

1.1.2 Planning application

1.1.2.1 Minimum mounting clearances of two readers

The RF620R has a circular polarized antenna. At 500 mW ERP radiated power, due to the opening angle of the antennas, their fields can overlap considerably. It is no longer possible to clarify in which antenna field access to the data of a tag is performed.

In order to avoid this, always keep a minimum distance of 3 m between two readers with the maximum radiated power of 500 mW ERP.

Dense Reader Mode (DRM)

The readers can also interfere with each other (secondary fields), if the channels (Reader TX, Transponder TX) overlap. In order to prevent a transponder channel overlapping with a reader channel, we recommend that the Dense Reader Mode (DRM) is used.

1.1.2.2 Antenna diagram for RF620R (ETSI)

The following radiation diagrams show the directional radiation pattern of the internal antenna of the RF620R (ETSI) reader. For the spatial presentation of the directional radiation pattern, the vertical plane in space (Azimuth section) as well as the horizontal plane (elevation section) must be considered. This results in a spatial image of the directional radiation pattern of the antenna with its main and auxiliary fields.

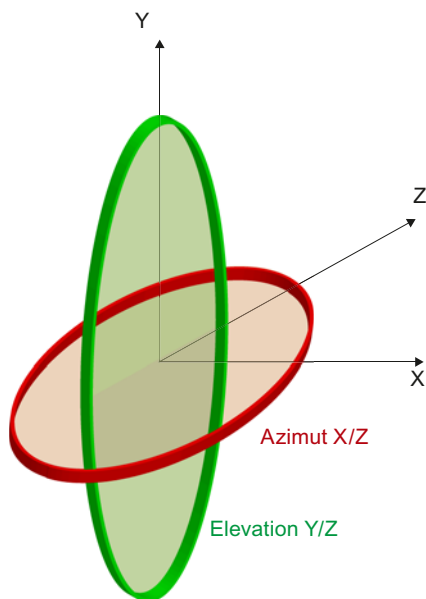

Radiation diagram (Azimuth section)

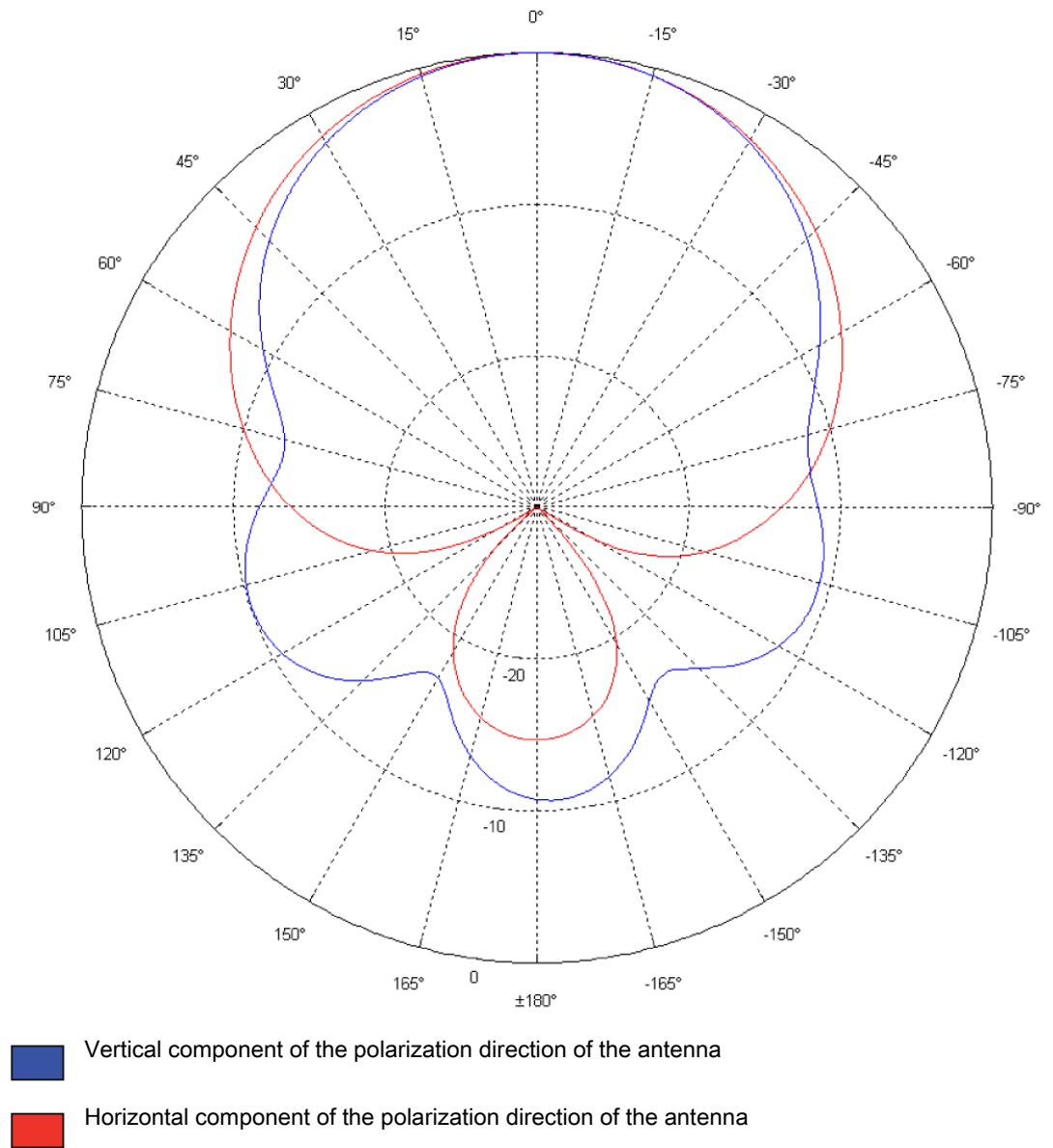

Figure 1-1 Azimuth section

Radiation diagram (elevation section)

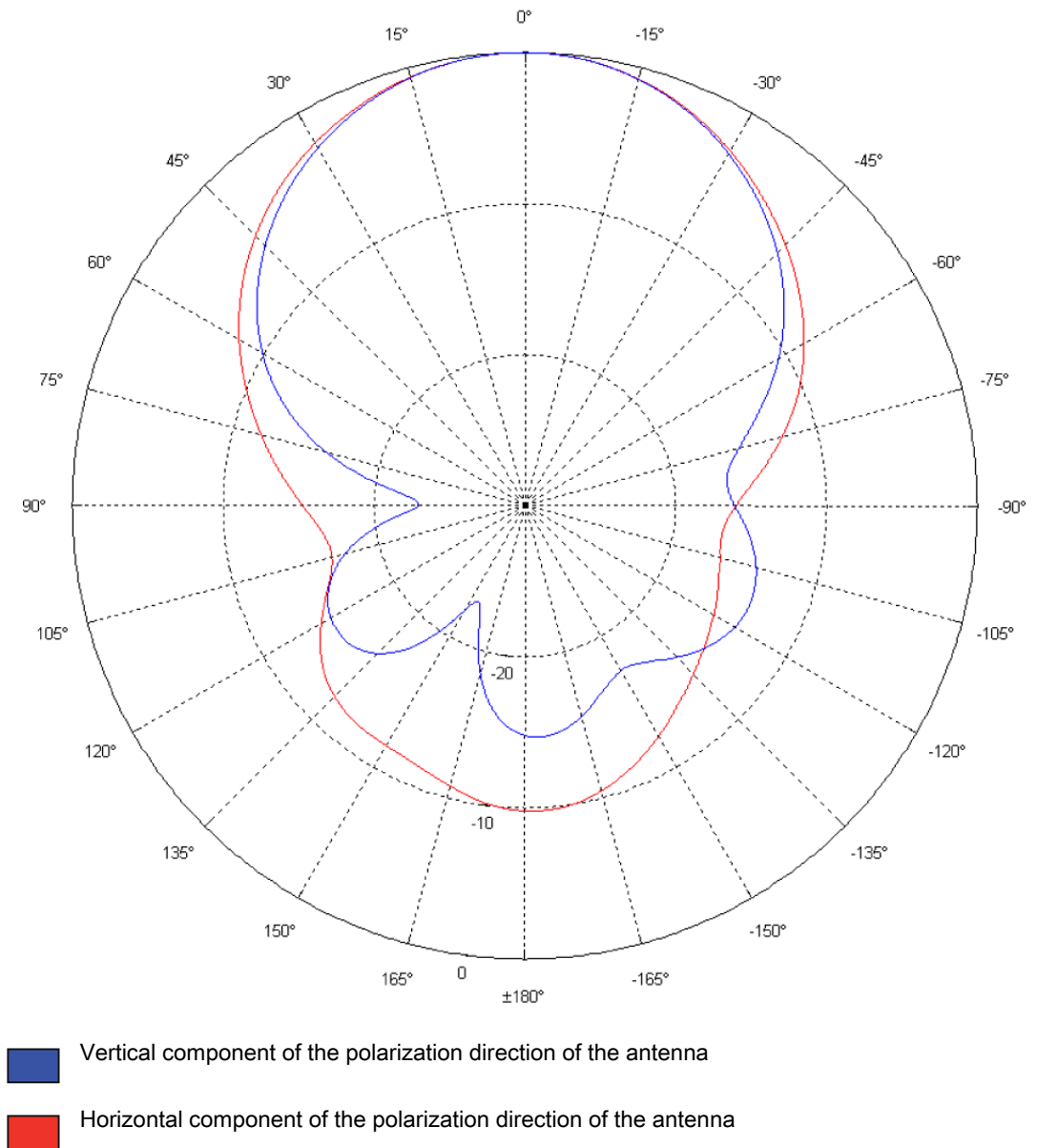

Figure 1-2 Elevation section

Overview of the antenna parameters

Table 1- 2 Maximum linear electrical opening angle at 865 MHz:

Azimuth section	77,7°
Elevation section	66,1°
Typical antenna gain in the frequency range 865 to 868 MHz	7,3 dBic
Antenna axis ratio	0,7 dB

See also Chapter Guidelines for selecting RFID UHF antennas (Page Fehler! Textmarke nicht definiert.)

1.1.2.3 Antenna/read point configurations

The RF620R reader has an internal circular polarized antenna. You can cover one read point with this antenna. When several RF620R readers are used, the readers are addressed via the SIMATIC level.

1.1.3 Installing/Mounting

Requirement

 WARNING
Ensure that the wall or ceiling can hold four times the total weight of the device.

Mounting/installing the device

You can mount the reader in two different ways:

- Via a standardized VESA 100 mounting system using the Antenna Mounting Kit (see Chapter Mounting with antenna mounting kit (Page Fehler! Textmarke nicht definiert.))
- Directly onto a flat surface.

The positions of the fixing holes for the device are shown in the section Dimension drawings (Page 20).

1.1.4 Configuration/integration

The RS422 system interface is provided for integrating the device into system environments/networks. The system interface transfers the data to SIMATIC controllers or PCs with the appropriate interface.

Apart from transmitting communication data from the reader to the controller and vice versa, the RS422 interface also supplies power to the reader (24 V DC).

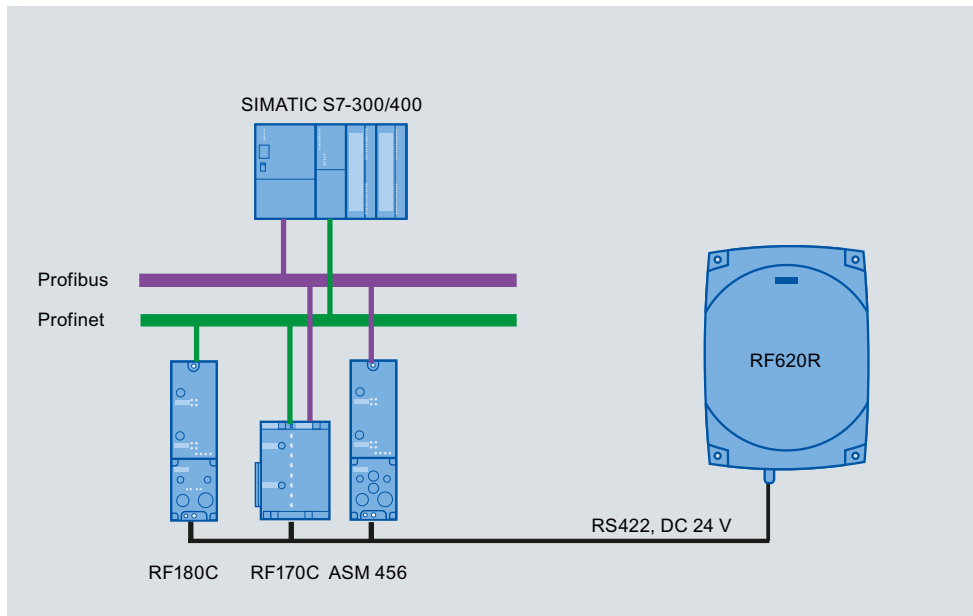

Figure 1-3 Overview of configuration of the RF620R reader

The RF620R reader can alternatively be connected to a SIMATIC controller via the ASM 456, RF170C or RF180C interface modules/communication modules.

For further details on the interface modules used, see Chapter RF660R (Page **Fehler! Textmarke nicht definiert.**) .

Further information about commissioning the readers can be found in the configuration manual "RF620R/RF630R" in the "Commissioning" section.

1.1.4.1 Transmission protocols

RS 422 communication

	3964R protocol
Transmission rates	19.2 Kbaud/s 57.6 Kbaud 115,2 Kbaud/s
Start bits	1
Data bits	8
Parity	Odd
Stop bits	1

1.1.5 Technical data

1.1.5.1 Mechanical data

Mechanical data		
Weight	1850 g	
Dimensions (L x W x H) in mm	252 X 193 x 52 mm, without connections	
Material for housing top section	ABS (GF 20)	
Material for housing bottom section	Aluminum	
Color of housing top section	Pastel turquoise	
Color of housing bottom section	Silver	
Status displays on the device	1 LED Colors: Red, yellow, green	
Interfaces		
	RS422	1 x plug (8-pin M12)
	Software	SIMATIC S7

Technical properties			
MTBF (Mean Time Between Failures)		16 years	
Supply voltage		Current consumption (in standby mode, no transmit power)	Power consumption (in standby mode, no transmit power)
	20 V input voltage on the reader, typical	135 mA	2.7 W
	24 V input voltage on the reader, typical	115 mA	2.76 W
	30 V input voltage on the reader, typical	95 mA	2.85 W
Supply voltage		Current consumption (at 500 mW ERP)	Power requirement (at 500 mW ERP)
	20 V input voltage on the reader, typical	470 mA	9.4 W

Readers

1.1 RF620R reader

	24 V input voltage on the reader, typical	395 mA	9.48 W
	30 V input voltage on the reader, typical	320 mA	9.6 W
	Ramp-up time, typical	7 s	

Mechanical environmental conditions	
Shock resistant to EN 60068-2-27	50 g ¹
Vibration EN 60068-2-6	20 g ¹
Climatic Conditions	
Ambient temperature during operation	-25 °C to +55 °C (warm-up time of 10 minutes must be observed)
Ambient temperature for transport and storage	-40 °C to +85 °C

EMC & approvals RF620R (ETSI)	
Electromagnetic compatibility	ETSI EN 301 489-1 / -3 ETSI EN 302 208
Approvals	<ul style="list-style-type: none"> • Radio to R&TTE- guidelines EN 300 330, EN 301 489 • CE • ETSI EN 302-208 V1.1.2 • ETSI EN 302-208 V1.2.1 • Reader degree of protection acc. to EN 60529 (IP65)

1) The values for shock and vibration are maximum values and must not be applied continuously.

1.1.5.2 Technical data according to EPC and ISO

Technical data	
Frequency accuracy	max.± 10 ppm
Channel spacing	EU: 200 kHz US: 500 kHz China: 250 kHz
Modulation methods	ASK: DSB modulation & PR-ASK modulation Encoding, Manchester or Pulse Interval (PIE)
Effective Radiant Power (the radiant power depends on the antennas and cables used, see Guidelines for selecting RFID UHF antennas (Page Fehler! Textmarke nicht definiert.))	≤ 0.5 W ERP

ETSI frequencies	
Frequency bands for EU, EFTA, Turkey:	865 to 868 MHz (10 subchannels LBT at 2 W ERP, 12 subchannels at 0.5 W ERP, 15 subchannels LBT at 0.1 W ERP)

Read distance for EU, EFTA, Turkey / China	
Readers mounted on the same side	Max. 2 m (recommended maximum value for configuration; depending on the transponder)

1.1.5.3 Maximum number of readable tags

The maximum number of readable tags depends on the following parameters:

- Size of the antenna field
- Readability of the tags

For a transmit power of 500 mW ERP, the following is read when the tag RF620T is used:

- Max. 40 tags in the antenna field (tags perpendicular to antenna and 1 m in front)
- Max. 18 tags per second

1.1.6 Dimension drawings

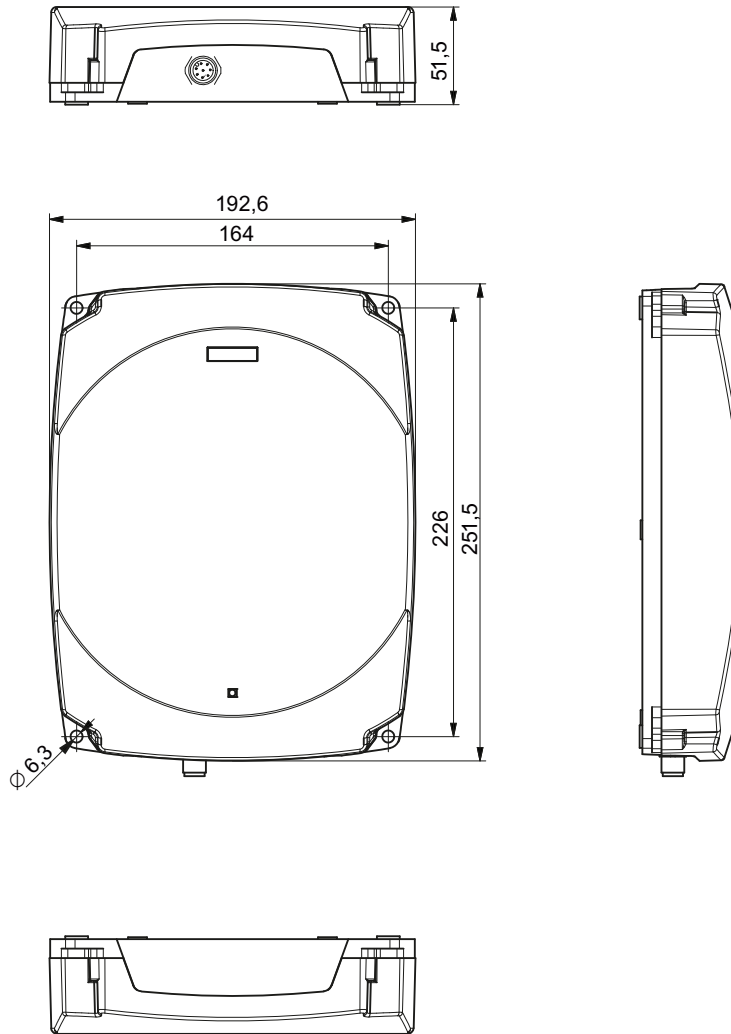



Figure 1-4 Dimension drawing for RF620R



All dimensions in mm

1.1.7 Certificates and approvals

Certificate	Description
	CE Approval to R&TTE

1.1.8 Certificates RF620R (FCC)

Tabelle 1- 3 6GT2811-5BA00-1AA0

Norm	
 Federal Communications Commission	FCC CFR 47, Part 15 sections 15.247 Radio Frequency Interference Statement This equipment has been tested and found to comply with the limits for a Class B digital device, pursuant to Part 15 of the FCC Rules. FCC ID: NXW-RF620R
Industry Canada Radio Standards Specifications	RSS-210 Issue 7, June 2007 ,Sections 2.2, A8 IC: 267X-RF620R
 C US	Dieses Produkt ist nach UL für USA und Canada zertifiziert. Es erfüllt folgende Standard(s) for Safety: UL 60950-1 - Information Technology Equipment Safety - Part 1: General Requirements CSA C22.2 No. 60950 -1 - Safety of Information Technology Equipment UL Report E 205089

1.1.9 FCC Information

Siemens SIMATIC RF620R (FCC): 6GT2811-5BA00-1AA0

FCC ID: NXW-RF620R

This device complies with part 15 of the FCC rules.

Operation is subject to the following two conditions:

- (1) This device may not cause harmful interference, and
- (2) This device must accept any interference received, including interference that may cause undesired operation.

Caution

Any changes or modifications not expressly approved by the party responsible for compliance could void the user's authority to operate the equipment.

Note

This equipment has been tested and found to comply with the limits for a Class B digital device, pursuant to part 15 of the FCC Rules. These limits are designed to provide reasonable protection against harmful interference when the equipment is operated in a commercial environment. This equipment generates, uses, and can radiate radio frequency energy and, if not installed and used in accordance with the instruction manual, may cause harmful interference to radio communications. Operation of this equipment in a residential area is likely to cause harmful interference in which case the user will be required to correct the interference at his own expense.

FCC Notice

To comply with FCC part 15 rules in the United States, the system must be professionally installed to ensure compliance with the Part 15 certification.

It is the responsibility of the operator and professional installer to ensure that only certified systems are deployed in the United States. The use of the system in any other combination (such as co-located antennas transmitting the same information) is expressly forbidden.

FCC Exposure Information

To comply with FCC RF exposure compliance requirements, the RF620R Reader (antenna and transmitter) must be installed to provide a separation distance of at least 20 cm from all persons and must not be co-located or operating in conjunction with any other antenna or transmitter.

1.2 RF630R reader

1.2.1 Description

The SIMATIC RF630R is an active stationary reader in the UHF frequency range without an integrated antenna. Up to two external UHF RFID antennas can be connected via TNC reverse connections.

The maximum HF power output is 0.5 W on the reader output. The SIMATIC RF630R is connected to a SIMATIC S7 controller via an ASM interface module. The degree of protection is IP65.

	Item	Description
	(1)	TNCreverse interface for connection of antenna 1 (ANT 1)
	(2)	TNCreverse interface for connection of antenna 2 (ANT 2)
	(2)	LED operating indicator
	(3)	RS 422 interface (8-pin M12 connector)

Highlights

- The tags are read in accordance with the requirements of the EPCglobal Class 1, Gen 2 and ISO/IEC 18000-6C standards
- Supports low-cost SmartLabels as well as reusable, rugged data media
- High reading speed: Depending on the function block (multitag mode), many tags can be detected simultaneously (bulk reading), rapidly moving tags are reliably acquired.
- The RF630R (ETSI) "6GT2811-4AA00-0AA0" is suitable for the frequency band 865 to 868 MHz UHF (EU, EFTA, Turkey).
- Up to 2 external antennas can be connected and configured in operating mode
- IP65 degree of protection for reader
- Can be used for a high temperature range
- Dense Reader Mode (DRM) for environments in which many readers are operated in close proximity to each other
- TIA system interface:
 - RS 422

1.2.1.1 Ordering data

Device	Order No.
RF630R (ETSI) reader basic unit for EU, EFTA, Turkey	6GT2811-4AA00-0AA0
RF660A antennas for EU, EFTA, Turkey (868 MHz)	6GT2812-0AA00

Accessories	Description	Order No.
Antenna cable	3 m (cable attenuation: 1,0 dB)	6GT2815-0BH30
	10 m (cable attenuation: 4,0 dB)	6GT2815-0BN10
	20 m (cable attenuation: 4,0 dB)	6GT2815-0BN20
Connecting cable	RS 422, M12 plug, 8-pin socket: 2 m	6GT289-0FH20
	RS 422, M12 plug, 8-pin socket: 5 m	6GT289-0FH50
	RS 422, M12 plug, 8-pin socket: 10 m	6GT289-0FN10
	RS 422, M12 plug, 8-pin socket: 20 m	6GT289-0FN20
	RS 422, M12 plug, 8-pin socket: 50 m	6GT289-0FN50
Software & Documentation	RFID CD-ROM	6GT2080-2AA10

1.2.1.2 Status display

The device is equipped with a three colored LED. The LED can be lit in green, red or yellow. The meaning of the indication changes in accordance with the color and state (on, off, flashing) of the LED:

Green LED	Red LED	Yellow LED	Meaning
Off	Off	Off	The device is starting up.
Flashing	Off	Off	The device is ready. The antenna is switched off.
On	Off	Off	The device is ready. The antenna is switched on.
Off	Off	On	"With presence": At least one tag is in the field. "Without presence": Communication with a tag is active.
Off	Flashing	Off	Reader is not active, a serious error has occurred. In addition, this LED also indicates the fault status through the number of flashing pulses. Reboot (operating voltage Off → On is necessary). The LED flashes once for the 'INACTIVE' status, rebooting is not necessary in this case.

For more detailed information on the flash codes of the reader see Chapter Error messages and flash codes for RF620R/RF630R (Page **Fehler! Textmarke nicht definiert.**)

Note

LED not lit yellow?

If the LED does not light up yellow even though a tag is located within the field, common causes are:

- Incorrect configuration in the init_run command, or init_run command was not executed (see "Configuration Manual RF620R/RF630R")
- Antenna is switched off
- A tag is used, that is not compatible with the reader protocol (EPC Global Class 1 Gen 2).
- Tag is defective
- Reader or antenna has a defect
- Tag is not in the field of radiation of the transmit antenna

1.2.1.3 Pin assignment of the RS422 interface

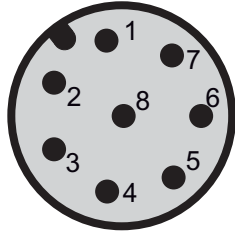
Pin	Pin Device end 8-pin M12	Assignment
	1	+ 24 V
	2	- Transmit
	3	0 V
	4	+ Transmit
	5	+ Receive
	6	- Receive
	7	Free
	8	Earth (shield)

The knurled bolt of the M12 plug is not connected to the shield (on the reader side).

Note

You must therefore not use any SIMATIC connecting cables that use the angled M12 plug.

1.2.1.4 Pin assignment of the connecting cable

Table 1- 4 RS 422 - on reader side

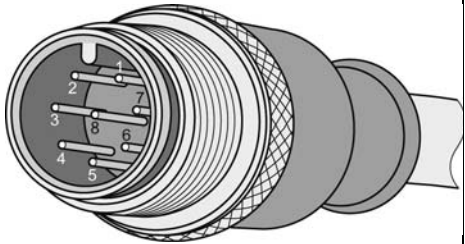
M12 pin	Core color	Pin assignment	View of M12 connector
1	white	24 V DC	
2	brown	TX neg	
3	green	GND	
4	yellow	TX pos	
5	Gray	RX pos	
6	pink	RX neg	
7	blue	Not used	
8	red	Earth (shield)	

Note

This cable has an 8-pin M12 connector at one end and the other cable end is 'open'. There are 8 color-coded single cores there for connecting to external devices. There are different cable lengths in the product range (3 m to 50 m). Long cables can be reduced if necessary.

Note

For long cables: Adapt supply voltage and data rate accordingly

Note that with long cables in particular, the supply voltage of 24 V DC must always be applied. Note also that the data rate on the serial interface must, if necessary, be reduced. (See "Configuration Manual RF620R/RF630R")

1.2.1.5 Grounding connection

The RF620R/RF630R can be electrically connected to the ground potential through a contact washer. The tightening torque must be increased in this case to ensure that electrical contact is made (2.7 Nm).

Ground connection	
	(a) Hexagon-head screw
	(b) Plain washer
	(c) Cable lugs
	(d) Contact washer: Use contact washers according to the Siemens standard SN 70093-6-FSt-flNnc-480h for ground connection, Siemens item No.: H70093-A60-Z3

1.2.2 Planning application

1.2.2.1 Minimum mounting clearances of two antennas of different readers

At 500 mW ERP radiated power, due to the opening angle of the antennas, their fields can overlap considerably. It is no longer possible to clarify in which antenna field access to the data of a tag is performed.

In order to avoid this, always keep a minimum distance of 3 m between two antennas of different RF630R readers with the maximum radiated power of 500 mW ERP.

Dense Reader Mode (DRM)

The readers can also interfere with each other (secondary fields), if the channels (Reader TX, Transponder TX) overlap. In order to prevent a transponder channel overlapping with a reader channel, we recommend that the Dense Reader Mode (DRM) is used.

1.2.2.2 Antenna/read point configurations

You can connect up to two external antennas to the RF630R reader. You have 3 possibilities for aligning the antennas and covering the read point.

One RF630R reader with two antennas and two read points

If you connect two external antennas to the device and align them in different directions, you can read tags at two different read points. With this technique, a particular antenna must be switched off application-dependently to be able to establish which tags have been read from which antenna. The reader also provides a mode for this purpose in which the antennas can be switched on and off cyclically (both antennas must be connected). Note the minimum distances between the antennas for the antenna configuration (see Chapter Specified minimum and maximum spacing of antennas (Page Fehler! Textmarke nicht definiert.) .

One RF630R reader with two antennas and one read point

If you connect two external antennas to the device and align them in the same direction (portal configuration), you can read tags at one read point. With this method, the reader automatically switches between the two antennas while the tags are being read. Note the minimum distances between the antennas for the antenna configuration (see Chapter Specified minimum and maximum spacing of antennas (Page Fehler! Textmarke nicht definiert.) .

One RF630R reader with one antenna and one read point

If you connect an external antenna to the device, you can read tags at one read point.

1.2.3 Installing/Mounting

Requirement

 WARNING
Ensure that the wall or ceiling can hold four times the total weight of the device.

Mounting/installing the device

You can mount the reader directly onto a flat surface.

The positions of the fixing holes for the device are shown in the section Dimension drawings (Page 32).

1.2.4 Configuration/integration

1.2.4.1 Configuration

The RS422 system interface is provided for integrating the device into system environments/networks. The system interface transfers the data to SIMATIC controllers or PCs with the appropriate interface.

Apart from transmitting communication data from the reader to the controller and vice versa, the RS422 interface also supplies power to the reader (24 V DC).

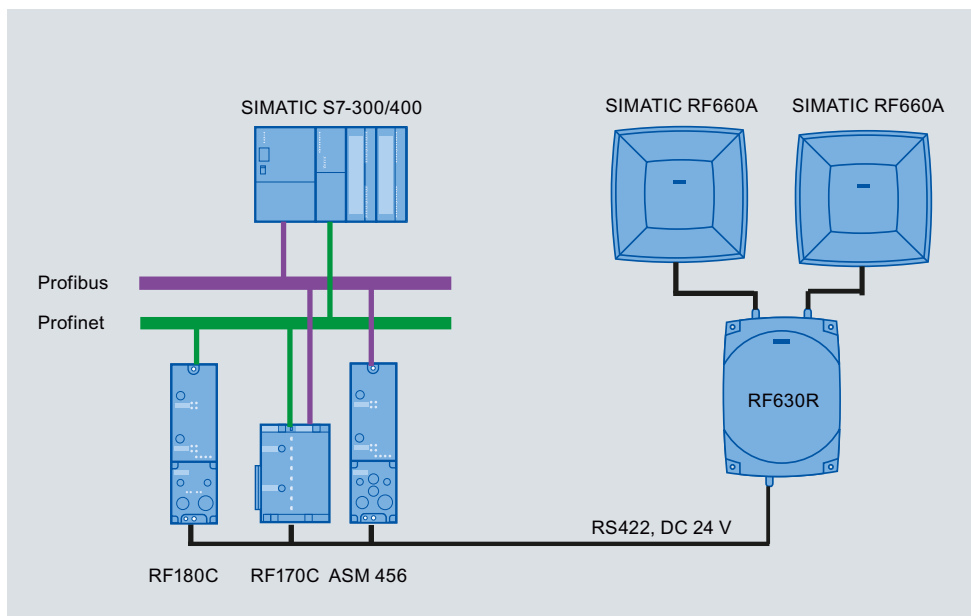

Figure 1-5 Overview of configuration of the RF630R reader

The RF620R reader can alternatively be connected to a SIMATIC controller via the ASM 456, RF170C or RF180C interface modules/communication modules.

For further details on the interface modules used, see Chapter RF660R (Page **Fehler! Textmarke nicht definiert.**).

Further information about commissioning the readers can be found in the Configuration Manual "RF620R/RF630R" in the "Commissioning" section.

1.2.4.2 Transmission protocols

RS 422 communication

	3964R protocol
Transmission rates	19.2 Kbaud/s 57.6 Kbaud 115,2 Kbaud/s
Start bits	1
Data bits	8
Parity	Odd
Stop bits	1

1.2.5 Technical data

1.2.5.1 Mechanical data

Mechanical data	
Weight	1640 g
Dimensions (L x W x H) in mm	252 x 193 x 52 mm, without connections
Material for housing top section	ABS (GF 20)
Material for housing bottom section	Aluminum
Color of housing top section	Anthracite
Color of housing bottom section	Silver
Status displays on the device	1 LED Colors: Red, yellow, green
Interfaces	
Antenna connections	2x RTNC plug
RS422	1 x plug (8-pin M12)
Software	SIMATIC S7

Technical properties		
MTBF (Mean Time Between Failures)	16 years	
Supply voltage	Current consumption (in standby mode, no transmit power)	Current consumption (in standby mode, no transmit power)
20 V input voltage on the reader, typical	135 mA	2.7 W
24 V input voltage on the reader, typical	115 mA	2.76 W
30 V input voltage on the reader, typical	95 mA	2.85 W

Readers

1.2 RF630R reader

Supply voltage	Current consumption (at 500 mW ERP)	Power requirement (at 500 mW ERP)
20 V input voltage on the reader, typical	470 mA	9.4 W
24 V input voltage on the reader, typical	395 mA	9.48 W
30 V input voltage on the reader, typical	320 mA	9.6 W
Rampup time	7 s	

Mechanical environmental conditions	
Shock resistant to EN 60068-2-27	50 g ¹
Vibration EN 60068-2-6	20 g ¹
Climatic Conditions	
Ambient temperature during operation	-25 °C to +55 °C (warm-up time of 10 minutes must be observed)
Ambient temperature for transport and storage	-40 °C to +85 °C

EMC & approvals for ETSI variant	
Electromagnetic compatibility	ETSI EN 301 489-1 / -3 ETSI EN 302 208
Approvals	<ul style="list-style-type: none"> • Radio to R&TTE- guidelines EN 300 330, EN 301 489 • CE • ETSI EN 302-208 V1.1.2 • ETSI EN 302-208 V1.2.1 • Reader degree of protection acc. to EN 60529 (IP65)

¹⁾ The values for shock and vibration are maximum values and must not be applied continuously.

1.2.5.2 Technical data according to EPC and ISO

Technical data	
Frequency accuracy	max. ± 10 ppm
Channel spacing	EU, EFTA, Turkey: 200 kHz US: 500 kHz China: 250 kHz
Modulation methods	ASK: DSB modulation & PR-ASK modulation Encoding, Manchester or Pulse Interval (PIE)
Effective radiant power (the radiant power depends on the antennas and cables used, see Guidelines for selecting RFID UHF antennas (Page Fehler! Textmarke nicht definiert.))	≤ 0.5 W ERP

ETSI frequencies	
Frequency bands for EU, EFTA, Turkey:	865 to 868 MHz (10 subchannels LBT at 2 W ERP, 12 subchannels at 0.5 W ERP, 15 subchannels LBT at 0.1 W ERP)

Read distance for EU, EFTA, Turkey / China	
Antennas mounted on opposing sides (portal configuration)	max. 3.5 m (recommended maximum value for configuration)
Antennas mounted on the same side	Max. 2 m (recommended maximum value for configuration; depending on the transponder)

1.2.5.3 Maximum number of readable tags

The maximum number of readable tags depends on the following parameters:

- Size of the antenna field
- Readability of the tags

For a transmit power of 500 mW ERP, the following is read when the tag RF620T is used:

- Max. 40 tags in the antenna field (tags perpendicular to antenna and 1 m in front)
- Max. 18 tags per second

1.2.6 Dimension drawings

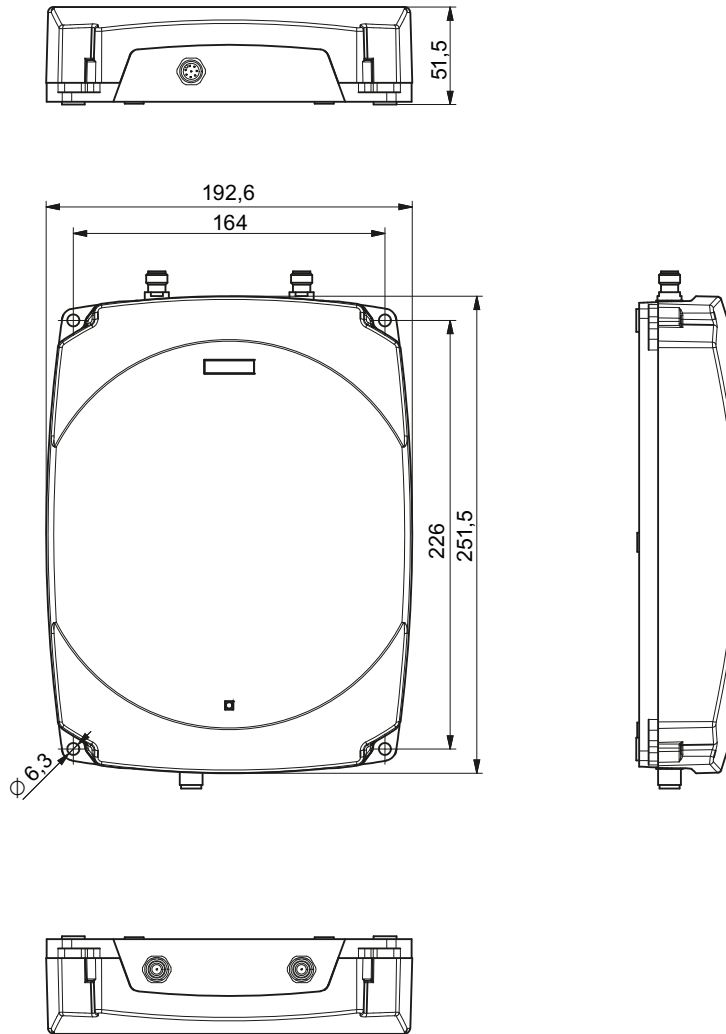



Figure 1-6 Dimension drawing for RF630R



All dimensions in mm

1.2.7 Certificates and approvals

Certificate	Description
	CE Approval to R&TTE

1.2.8 Certificates RF630R (FCC)

Tabelle 1- 5 6GT2811-4AA00-1AA0

Norm	
 Federal Communications Commission	FCC CFR 47, Part 15 sections 15.247 Radio Frequency Interference Statement This equipment has been tested and found to comply with the limits for a Class B digital device, pursuant to Part 15 of the FCC Rules. FCC ID: NXW-RF630R
Industry Canada Radio Standards Specifications	RSS-210 Issue 7, June 2007, Sections 2.2, A8 IC: 267X-RF630
 C US	Dieses Produkt ist nach UL für USA und Canada zertifiziert. Es erfüllt folgende Standard(s) for Safety: UL 60950-1 - Information Technology Equipment Safety - Part 1: General Requirements CSA C22.2 No. 60950 -1 - Safety of Information Technology Equipment UL Report E 205089

1.3 FCC Information

Siemens SIMATIC RF630R (FCC): 6GT2811-4AA00-1AA0

FCC ID: NXW-RF630R

This device complies with part 15 of the FCC rules.

Operation is subject to the following two conditions:

- (1) This device may not cause harmful interference, and
- (2) This device must accept any interference received, including interference that may cause undesired operation.

Caution

Any changes or modifications not expressly approved by the party responsible for compliance could void the user's authority to operate the equipment.

Note

This equipment has been tested and found to comply with the limits for a Class B digital device, pursuant to part 15 of the FCC Rules. These limits are designed to provide reasonable protection against harmful interference when the equipment is operated in a commercial environment. This equipment generates, uses, and can radiate radio frequency energy and, if not installed and used in accordance with the instruction manual, may cause harmful interference to radio communications. Operation of this equipment in a residential area is likely to cause harmful interference in which case the user will be required to correct the interference at his own expense.

FCC Notice To comply with FCC part 15 rules in the United States, the system must be professionally installed to ensure compliance with the Part 15 certification.

It is the responsibility of the operator and professional installer to ensure that only certified systems are deployed in the United States. The use of the system in any other combination (such as co-located antennas transmitting the same information) is expressly forbidden.

FCC Exposure InformationTo comply with FCC RF exposure compliance requirements, the antennas used for this transmitter must be installed to provide a separation distance of at least 20 cm from all persons and must not be co-located or operating in conjunction with any other antenna or transmitter.

1.4 IC-FCB Information

Siemens SIMATIC RF630R (FCC): 6GT2811-4AA00-1AA0

IC: 267X-RF630

Industry Canada NoticeTo reduce potential radio interference to other users, the antenna type and its gain should be so chosen that the equivalent isotropically radiated power (e.i.r.p.) is not more than that permitted for successful communication.

This device has been designed to operate with the SIMATIC RF660A antenna 902-928 listed below, and having a maximum gain of 5,5 dBi.

Other antennas or antennas having a gain greater than 5,5 dBi are strictly prohibited for use with this device.

The required antenna impedance is 50 Ohms

