

SIEMENS

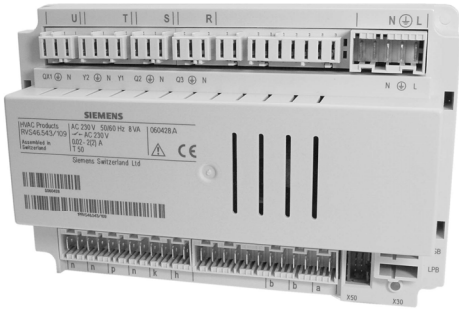

Albatros² Zone controller User Manual OEM

RVS46..
AVS75..
AVS37..
QAA75..
QAA78..
QAA55..

Table of contents

1	Overview of OEM settings	4
2	The settings in detail.....	15
2.1	Operator section	15
	Operation and display.....	15
2.2	Heating circuits	15
	mixing valve control	15
2.3	Domestic hot water	16
	Setpoints.....	16
	Release	16
2.4	Pump H1/H2	17
	pump H1	17
2.5	Primary controller / system pump	17
	flow temperature setpoint limitations	17
	mixing valve control	18
2.6	DHW storage tank	19
	Release	19
	Charging control	19
	Charging time limitation	20
	Discharging protection.....	20
	Overtemperature protection.....	21
	DHW push	21
2.7	Configuration	21
	Building and room model.....	21
	Parameters	22
2.8	LPB	22
	Error / maintenance / alarms	22
	Range of action of changeover.....	22
2.9	Error.....	23
	History 1...10	23
2.10	Diagnostics consumers	23
	Heating circuit 1, heating circuit 2, heating circuit P	23

1 Overview of OEM settings

The table below shows all available settings up to the heating engineer level. However, certain operating lines may be hidden, depending on the type of unit.

Legend

E = enduser I = commissioning F = heating engineer O = OEM
BZ = operating line

Operating line	User level	Function	Default value	Minimum	Max	Unit
Time of day and date						
1	E	Hours/minutes	-	00:00	23:59	hh:mm
2	E	Day/month	-	01.01	31.12	dd.mm
3	E	Year	-	2004	2099	yyyy
5	F	Start of summertime	25.03	01.01	31.12	dd.mm
6	F	End of summertime	25.10	01.01	31.12	dd.mm
Operator section						
20	E	Language German ...	German			-
22	F	Info Temporarily Permanently	Temporarily			-
26	F	Operation lock Off On	Off			-
27	F	Programming lock Off On	Off			-
30	O	Data:read No Yes	No			
31	O	Data:write No Yes	No			
40	I	Used as Room unit 1 Room unit 2 Operator unit Service unit	Room unit 1			-
42	I	assignment room unit 1 Heating circuit 1 Heating circuits 1 and 2	Heating circuit 1			-
44	I	Operation HC2 Commonly with HC1 Independently	Commonly with HC1			-
46	I	Operation HCP Commonly with HC1 Independently	Commonly with HC1			-
48	I	Action occupancy button None Heating circuit 1 Heating circuit 2 Commonly	Heating circuit 1			-
54	F	Readjustment room sensor	0.0	-3	3	°C
70	F	Software version	-	0	99.9	-
Wireless						
120	I	Binding No Yes	No			
121	I	Test mode Off On	Off			
130	I	Room unit 1 Missing Ready No reception Change batt	-			-
131	I	Room unit 2 Missing Ready No reception Change batt	-			-
132	I	Outside sensor Missing Ready No reception Change batt	-			-
133	I	Repeater Missing Ready No reception	-			-

Operating line	User level	Function	Default value	Minimum	Max	Unit
134	I	Operator unit Missing Ready No reception Change batt	-			-
135	I	Service unit Missing Ready No reception Change batt	-			-
138	I	Delete all devices No Yes	No			-
Time prog heating circuit 1						
500	E	Preselection Mo - Su Mo - Fr Sa - Su Mo Tu We Th Fr Sa ;Su	Mo - Su			-
501	E	1st phase on	6:00	00:00	24:00	hh:mm
502	E	1st phase off	22:00	00:00	24:00	hh:mm
503	E	2st phase on	24:00	00:00	24:00	hh:mm
504	E	2st phase off	24:00	00:00	24:00	hh:mm
505	E	3st phase on	24:00	00:00	24:00	hh:mm
506	E	3st phase off	24:00	00:00	24:00	hh:mm
516	E	Default values No Yes	No			-
Time prog heating circuit 2						
520	E	Preselection Mo - Su Mo - Fr Sa - Su Mo Tu We Th Fr Sa ;Su	Mo - Su			-
521	E	1st phase on	6:00	00:00	24:00	hh:mm
522	E	1st phase off	22:00	00:00	24:00	hh:mm
523	E	2st phase on	24:00	00:00	24:00	hh:mm
524	E	2st phase off	24:00	00:00	24:00	hh:mm
525	E	3st phase on	24:00	00:00	24:00	hh:mm
526	E	3st phase off	24:00	00:00	24:00	hh:mm
536	E	Default values No Yes	No			-
Time program 3 / HCP						
540	E	Preselection Mo - Su Mo - Fr Sa - Su Mo Tu We Th Fr Sa ;Su	Mo - Su			-
541	E	1st phase on	6:00	00:00	24:00	hh:mm
542	E	1st phase off	22:00	00:00	24:00	hh:mm
543	E	2st phase on	24:00	00:00	24:00	hh:mm
544	E	2st phase off	24:00	00:00	24:00	hh:mm
545	E	3st phase on	24:00	00:00	24:00	hh:mm
546	E	3st phase off	24:00	00:00	24:00	hh:mm
556	E	Default values No Yes	No			-
Time program 4 / DHW						
560	E	Preselection Mo - Su Mo - Fr Sa - Su Mo Tu We Th Fr Sa ;Su	Mo - Su			-
561	E	1st phase on	6:00	00:00	24:00	hh:mm
562	E	1st phase off	22:00	00:00	24:00	hh:mm
563	E	2st phase on	24:00	00:00	24:00	hh:mm
564	E	2st phase off	24:00	00:00	24:00	hh:mm
565	E	3st phase on	24:00	00:00	24:00	hh:mm
566	E	3st phase off	24:00	00:00	24:00	hh:mm

Operating line	User level	Function	Default value	Minimum	Max	Unit
576	F	Default values No ; Yes	No			-
Holidays heating circuit 1						
641	E	Preselection Period 1 ; Period 2 ; Period 3; Period 4; Period 5; Period 6; Period 7; Period 8	Periode 1			-
642	E	Start	--,--	01.01	31.12	dd.mm
643	E	End	--,--	01.01	31.12	dd.mm
648	E	Operating level Frost protection ; Reduced	Frost protection			-
Holidays heating circuit 2						
651	E	Preselection Period 1 ; Period 2 ; Period 3; Period 4; Period 5; Period 6; Period 7; Period 8	Periode 1			-
652	E	Start	--,--	01.01	31.12	dd.mm
653	E	End	--,--	01.01	31.12	dd.mm
658	E	Operating level Frost protection ; Reduced	Frost protection			-
Holidays heating circuit P						
661	E	Preselection Period 1 ; Period 2 ; Period 3; Period 4; Period 5; Period 6; Period 7; Period 8	Periode 1			-
662	E	Start	--,--	01.01	31.12	dd.mm
663	E	End	--,--	01.01	31.12	dd.mm
668	E	Operating level Frost protection ; Reduced	Frost protection			-
Heating circuit 1						
710	E	Comfort cooling setpoint	20.0	BZ 712	BZ 716	°C
712	E	Reduced setpoint	16	BZ 714	BZ 710	°C
714	E	Frost protection setpoint	10.0	4	BZ 712	°C
716	F	Comfort setpoint max	35.0	BZ 710	35	°C
720	E	Heating curve slope	1.50	0.10	4.00	-
721	F	Heating curve displacement	0.0	-4.5	4.5	°C
726	F	Heating curve adaption Off ; On	Off			-
730	E	Summer/winter heating limit	18	--- / 8	30	°C
732	F	24-hour heating limit	-3	--- / -10	10	°C
740	I	Flow temp setpoint min	8	8	BZ 741	°C
741	I	Flow temp setpoint max	80	BZ 740	95	°C
750	F	Room influence	20	--- / 0	100	%
760	F	Room temp limitation	---	--- / 0.5	4	°C
770	F	Boost heating	5	--- / 0	20	°C
780	F	Quick setback Off ; Down to reduced setpoint ; Down to frost prot setpoint	Down to reduced setpoint			-
790	F	Optimum start control max	0	0	360	min
791	F	Optimum stop control max	0	0	360	min
800	F	Reduced setp increase start	---	--- / -30	10	°C
801	F	Reduced setp increase end	-15	-30	BZ 800	°C
820	F	Overtemp prot pump circuit Off ; On	On			-
830	F	Mixing valve boost	10	0	50	°C

Operating line	User level	Function	Default value	Minimum	Max	Unit
832	F	Actuator:type 2-position ; 3-position	3-position			-
833	F	Switching differential 2-pos	2	0	20	°C
834	F	Actuator: running time	120	30	873	s
835	O	Mixing valve Xp	32	1	100	°C
836	O	Mixing valve Tn	120	10	873	s
850	I	Floor curing function Off ; Functional heating ; Curing heating ; Functional/curing heating ; Manually	Off			-
851	I	Floor curing setp manually	25	0	95	°C
861	F	Excess heat draw Off ; Heating mode ; Always	Always			
872	F	With prim contr/system pump No ; Yes	Yes			
900	I	Optg mode changeover Protection ; Recuced	Protection			
Heating circuit 2						
1010	E	Comfort cooling setpoint	20.0	BZ 1012	BZ 1016	°C
1012	E	Reduced setpoint	16	BZ 1014	BZ 1010	°C
1014	E	Frost protection setpoint	10.0	4	BZ 1012	°C
1016	F	Comfort setpoint max	35.0	BZ 1010	35	°C
1020	E	Heating curve slope	1.50	0.10	4.00	-
1021	F	Heating curve displacement	0.0	-4.5	4.5	°C
1026	F	Heating curve adaption Off ; On	Off			-
1030	E	Summer/winter heating limit	18	--- / 8	30	°C
1032	F	24-hour heating limit	-3	--- / -10	10	°C
1040	I	Flow temp setpoint min	8	8	BZ 1041	°C
1041	I	Flow temp setpoint max	80	BZ 1040	95	°C
1050	F	Room influence	20	--- / 0	100	%
1060	F	Room temp limitation	---	--- / 0.5	4	°C
1070	F	Boost heating	5	--- / 0	20	°C
1080	F	Quick setback Off ; Down to reduced setpoint ; Down to frost prot setpoint	Down to reduced setpoint			-
1090	F	Optimum start control max	0	0	360	min
1091	F	Optimum stop control max	0	0	360	min
1100	F	Reduced setp increase start	---	--- / -30	10	°C
1101	F	Reduced setp increase end	-15	-30	BZ 1100	°C
1120	F	Overtemp prot pump circuit Off ; On	On			-
1130	F	Mixing valve boost	10	0	50	°C
1132	F	Actuator:type 2-position ; 3-position	3-position			-
1133	F	Switching differential 2-pos	2	0	20	°C
1134	F	Actuator: running time	120	30	873	s
1135	O	Mixing valve Xp	32	1	100	°C
1136	O	Mixing valve Tn	120	10	873	s
1150	F	Floor curing function Off ; Functional heating ; Curing heating ; Functional/curing heating ; Manually	Off			-

Operating line	User level	Function	Default value	Minimum	Max	Unit
1151	F	Floor curing setp manually	25	0	95	°C
1161	F	Excess heat draw Off ; Heating mode ; Always	Always			
1172	F	With prim contr/system pump No ; Yes	Yes			
1200	I	Optg mode changeover Protection ; Recuded	Protection			
Heating circuit P						
1300	E	Operating mode Protection ; Automatic ; Reduced ; Comfort	Automatic			-
1310	E	Comfort cooling setpoint	20.0	BZ 1012	BZ 1016	°C
1312	E	Reduced setpoint	16	BZ 1014	BZ 1010	°C
1314	E	Frost protection setpoint	10.0	4	BZ 1012	°C
1316	F	Comfort setpoint max	35.0	BZ 1010	35	°C
1320	E	Heating curve slope	1.50	0.10	4.00	-
1321	F	Heating curve displacement	0.0	-4.5	4.5	°C
1326	F	Heating curve adaption Off ; On	Off			-
1330	E	Summer/winter heating limit	18	--- / 8	30	°C
1332	F	24-hour heating limit	-3	--- / -10	10	°C
1340	F	Flow temp setpoint min	8	8	BZ 1041	°C
1341	F	Flow temp setpoint max	80	BZ 1040	95	°C
1350	F	Room influence	20	--- / 0	100	%
1360	F	Room temp limitation	---	--- / 0.5	4	°C
1370	F	Boost heating	5	--- / 0	20	°C
1380	F	Quick setback Off ; Down to reduced setpoint ; Down to frost prot setpoint	Down to reduced setpoint			-
1390	F	Optimum start control max	0	0	360	min
1391	F	Optimum stop control max	0	0	360	min
1400	F	Reduced setp increase start	---	--- / -30	10	°C
1401	F	Reduced setp increase end	-15	-30	BZ 1100	°C
1420	F	Overtemp prot pump circuit Off ; On	On			-
1450	I	Floor curing function Off ; Functional heating ; Curing heating ; Functional/curing heating ; Manually	Off			-
1451	I	Floor curing setp manually	25	0	95	°C
1455	F	Floor curing setp current	0	0	95	°C
1456	F	Floor curing day current	0	0	32	°C
1461	F	Excess heat draw Off ; Heating mode ; Always	Always			
1172	F	With prim contr/system pump No ; Yes	Yes			
1500	I	Optg mode changeover Protection ; Recuded	Protection			
Domestic hot water						
1610	E	Nominal setpoint	55	BZ 1612	BZ 1614 OEM	°C
1612	F	Reduced setpoint	40	8	BZ 1610	°C
1614	O	Nominal setpoint max	65	8	80	°C
1620	I	Release 24h/day ; Time programs HCs ; Time program 4/DHW	Time programs HCs			-

Operating line	User level	Function	Default value		Minimum	Max	Unit
1630	I	Charging priority Absolute ; Shifting ; None ; MC shifting, PC absolute	MC shifting, PC absolute				-
1640	F	Legionella function Off ; Periodically ; Fixed weekday	Fixed weekday				-
1641	F	Legionella funct periodically	3	1	7		Days
1642	F	Legionella funct weekday Monday ; Tuesday ; Wednesday ; Thursday ; Friday ; Saturday ; Sunday	Montag				
1644	F	Legionella funct time	---	--- / 00:00	23:50		hh:mm
1645	F	Legionella funct setpoint	65	55	95		°C
1646	F	Legionella funct duration	30	--- / 10	360		min
1647	F	Legionella funct circ pump Off ; On	On				-
1660	F	Release of the circulating pump Time program 3/HCP ; DHW release ; Time program 4/DHW	DHW release				-
1661	F	Circulating pump cycling Off ; On	On				-
1663	F	Circulaton setpoint	45	8	80		°C
Pump H1/H2							
2008	O	H1 DHW charging priority No ; Yes	Yes				
2010	F	H1 Excess heat draw Off ; On	On				
2014	F	H1 prim contr/system pump No ; Yes	Yes				-
2033	O	H2 DHW charging priority No ; Yes	Yes				
2035	F	H2 Excess heat draw Off ; On	On				
2039	F	H2 prim contr/system pump No ; Yes	Yes				-
Primary controller / system pump							
2110	O	Flow temp setpoint min	8	8	95		°C
2111	O	Flow temp setpoint max	80	8	95		°C
2130	O	Mixing valve boost	10	0	50		°C
2132	O	Actuator:type 2-position ; 3-position	3-position				
2133	O	Switching differential 2-pos	2	0	20		°C
2134	O	Actuator: running time	120	30	873		°C
2135	O	Mixing valve Xp	32	1	100		°C
2136	O	Mixing valve Tn	120	10	873		°C
Solar							
3810	F	Temp diff on	8	BZ 3811	40		°C
3811	F	Temp diff off	4	0	BZ 3812		°C
3812	F	Charg temp min DHW st tank	---	--- / 8	95		°C
3830	F	Collector start function	---	--- / 5	60		min
3831	F	Min run time collector pump	60	5	120		s
3840	F	Collector frost protection	---	--- / -20	5		°C
3850	F	Collector overtemp prot	---	--- / 30	200		°C
3860	F	Evaporation heat carrier	---	--- / 60	200		°C

Operating line	User level	Function	Default value	Minimum	Max	Unit
DHW storage tank						
5010	O	Charging Once/day ; Several times/day	Several times / day			
5020	F	Increase of the flow temperature setpoint	16	0	30	°C
5022	F	Type of charging With B3 ; With B3/B31 ; With B3, legio B3/B31	With B3/B31			
5024	O	Switching diff	5	0	20	°C
5030	O	Charging time limitation	150	--- / 10	600	min
5040	O	Discharging protection Off ; Always ; Automatically	Automatic			
5050	F	Charging temp max	80	8	BZ 5051 OEM	°C
5051	O	Storage tank temp max	90	8	95	°C
5055	F	Recooling temp	60	8	95	°C
5056	F	Recooling heat gen/HCs Off ; On	Off			-
5057	F	Recooling collector Off ; Summer ; Always	Off			-
5060	F	Electric immersion heater:operating mode Substitute ; Summer ; Always	Substitute			-
5061	F	Electric immersion heater:release 24h/day ; DHW release ; Time program4/ DHW	DHW release			-
5062	F	EI immersion heater control External thermostat ; DHW sensor	DHW sensor			-
5070	O	Automatic push Off ; On	On			
5085	F	Excess heat draw Off ; On	On			-
5092	F	With prim contr/system pump No ; Yes	No			
5093	F	With solar integration No ; Yes	Yes			
Configuration						
5710	I	Heating circuit 1 Off ; On	On			-
5715	I	Heating circuit 2 Off ; On	On			-
5730	I	DHW sensor B3 Sensor ; Thermostat	Sensors			-
5731	I	DHW controlling element Q3 None ; Charging pump ; Diverting valve	charging pump			-
5890	I	Relay output QX1 None ; Circulating pump Q4 ; EI imm heater DHW K6 ; Collector pump Q5 ; H1 pump Q15 ; Alarm output K10 ; 2nd pump speed HC1 Q21 ; 2nd pump speed HC2 Q22 ; 2nd pump speed HCP Q23 ; Heat circuit pump HCP Q20 ; H2 pump ; Q18 primary pump Q14	None			-
5930	I	Sensor input BX1 None ; DHW sensor B31 ; Collector sensor B6 ; DHW circulation sensor B39	None			-
5931	I	Sensor input BX2 None ; DHW sensor B31 ; Collector sensor B6 ; DHW circulation sensor B39	None			-

Operating line	User level	Function	Default value		Max	Unit
				Minimum		
5950	I	Function input H1 Optg mode change HCs+DHW ; Optg mode changeover HCs ; Optg mode changeover HC1 ; Optg mode changeover HC2 ; Optg mode changeover HCP ; Error/alarm message ; Min flow temp setpoint ; Excess heat discharge	Optg mode change HCs+DHW			-
5951	I	Contact type H1 NC ; NO	NO contact			-
5952	I	Min flow temp setpoint H1	70	8	120	°C
5954	I	Heat request 10V H1	100	5	130	°C
5956	I	Pressure value 3.5V H1	5.0	0.0	10.0	bar
5960	I	Function input H2 Optg mode change HCs+DHW ; Optg mode changeover HCs ; Optg mode changeover HC1 ; Optg mode changeover HC2 ; Optg mode changeover HCP ; Heat generation lock ; Error/alarm message ; Min flow temp setpoint ; Heat request ; Pressure measurement	Optg mode change HCs+DHW			-
5961	I	Contact type H2 NC ; NO	NO contact			-
5962	I	Min flow temp setpoint H2	70	8	120	°C
6014	I	Function mixing group 1 Heating circuit ; Prim contr/system pump	Heating circuit			-
6020	I	Function extension module 1 None ; Multi-functional ; Heating circuit ; Solar DHW ; Prim contr/system pump	No function			-
6021	I	Function extension module 2 None ; Multi-functional ; Heating circuit ; Solar DHW ; Prim contr/system pump	No function			-
6097	F	Sensor type collector NTC 10k ; Platinum 1000	NTC			
6030	I	Relay output QX21 None ; Circulating pump Q4 ; EI imm heater DHW K6 ; Collector pump Q5 ; H1 pump Q15 ; Alarm output K10 ; 2nd pump speed HC1 Q21 ; 2nd pump speed HC2 Q22 ; 2nd pump speed HCP Q23 ; Heat circuit pump HCP Q20 ; H2 pump ; Q18 primary pump Q14	None			-
6031	I	Relay output QX22 None ; Circulating pump Q4 ; EI imm heater DHW K6 ; Collector pump Q5 ; H1 pump Q15 ; Alarm output K10 ; 2nd pump speed HC1 Q21 ; 2nd pump speed HC2 Q22 ; 2nd pump speed HCP Q23 ; Heat circuit pump HCP Q20 ; H2 pump ; Q18 primary pump Q14	None			-
6040	I	Sensor input Bx21 None ; DHW sensor B31 ; Collector sensor B6 ; DHW circulation sensor B39	None			-
6041	I	Sensor input BX22 None ; DHW sensor B31 ; Collector sensor B6 ; DHW circulation sensor B39	None			-
6097		Sensor type collector NTC 10k ; Platinum 1000	NTC			
6098	F	Readjustm collector sensor	0	-20	20	°C
6100	F	Readjustm outside sensor	0.0	-3.0	3.0	°C
6110	F	Time constant building	15	0	50	h
6112	O	Gradient room model	60	0	300	min/°C
6120	F	Frost protection plant Off ; On	On			-
6200	I	Saving sensors No ; Yes	No			-

Operating line	User level	Function	Default value	Minimum	Max	Unit
6204	O	Save parameters No ; Yes	No			
6205	F	Reset to default parameters No ; Yes	No			-
6212	I	Check no heat source 1	-	0	199999	-
6215	I	Check no storage tank	-	0	199999	-
6217	I	Check no heating circuits	-	0	199999	-
6220	F	Software version	-	0	99.9	-
6222	O	Device hours run	0	0	500 000	h
LPB						
6600	I	Device address	1	0	16	-
6601	F	Segment address	0	0	14	-
6604	F	Bus power supply function Off ; Automatically	Automatic			-
6605	F	Bus power supply state Off ; On	On			-
6610	O	Display system messages No ; Yes	Yes			
6612	O	Alarm delay No ; Yes	No			
6620	O	Action changeover functions Segment ; System	System			-
6621	F	Summer changeover Locally ; Centrally	Local			-
6625	F	DHW assignment Local HCs ; All HCs in segment ; All HCs in system	All heating circuits in the system			-
6640	I	Clock mode Autonomously ; Slave without remote ; Slave with remote setting ; Master	Autonomous			-
6650	F	Outside temp source	0	0	239	-
Error						
6710	I	Reset:alarm relay No ; Yes	No			-
6740	F	Flow temp 1 alarm	---	--- / 10	240	min
6741	F	Flow temp 2 alarm	---	--- / 10	240	min
6800	F	History 1	-			
	F	Error code 1	-	0	255	-
6802	F	History 2	-			
	F	Error code 1	-	0	255	-
6804	F	History 3	-			
	F	Error code 1	-	0	255	-
6806	F	History 4	-			
	F	Error code 1	-	0	255	-
6808	F	History 5	-			
	F	Error code 1	-	0	255	-
6810	F	History 6	-			
	F	Error code 6	-	0	255	-
6812	F	History 7	-			
	F	Error code 7	-	0	255	-
6814	F	History 8	-			
	F	Error code 8	-	0	255	-

Operating line	User level	Function	Default value	Minimum	Max	Unit
6816	F	History 9	-			
	F	Error code 9	-	0	255	-
6818	F	History 10	-			
	F	Error code 10	-	0	255	-
6820	O	Reset history No Yes	No			-
Maintenance/service						
7140	E	manual control Off On	Off			-
7150	I	Simulation outside temp	-	-50.0	50	°C
7170	I	Telephone customer service				-
Input/output test						
7700	I	Relay test No test Everything off DHW pump Q3 Heating circuit pump Q2 Heat circ mix valve op Y1 Heat circ mix valve cl Y2 Relay output QX1 Relay output QX21 module 1 Relay output QX22 module 1 Relay output QX23 module 1 Relay output QX21 module 2 Relay output QX22 module 2 Relay output QX23 module 2	No test			-
7730	I	Outside temp B9	-	-50.0	50	°C
7732	I	Flow temp B1	-	0.0	140	°C
7750	I	DHW temp B3	-	0.0	140	°C
7820	I	Sensor temp BX1	-	-28.0	350	°C
7821	I	Sensor temp BX2	-	-28.0	350	°C
7830	I	Sensor temp BX21 module 1	0	-28	350	°C
7831	I	Sensor temp BX22 module 1	0	-28	350	°C
7832	I	Sensor temp BX21 module 2	0	-28	350	°C
7833	I	Sensor temp BX22 module 2	0	-28	350	°C
7841	I	Contact state H1 Open Closed	Open			-
7846	I	Contact state H2 Open Closed	Open			-
Status:						
8000	I	State heating circuit 1	-			-
8001	I	State heating circuit 2	-			-
8002	I	State heating circuit P	-			-
8003	I	State DHW	-			-
8007	I	State solar	-			-
Diagnostics heat source						
8510	I	Collector temp 1	-	-28.0	350	°C
8511	I	Collector temp 1 max	0	-28.0	350	°C
8512	I	Collector temp 1 min	0	-28.0	350	°C
8513	I	dT collector 1/DHW	-	-28.0	350	°C
8514	I	dT collector 1/buffer	-	-28.0	350	°C
8530	F	Hours run solar yield	-	0	65535	h
8531	F	Hours run collect overtemp	-	0	65535	h
Diagnostics consumers						
8700	I	Outside temperature	-	-50.0	50.0	°C
8703	I	Outside temp attenuated	-	-50.0	50.0	°C
8704	I	Composite outside temperature	-	-50.0	50.0	°C

Operating line	User level	Function	Default value	Minimum	Max	Unit
8730	I	Heating circuit pump Q2 Off ; On	-			-
8731	I	Heat circ mix valve op Y1 Off ; On	-			-
8732	I	Heat circ mix valve cl Y2 Off ; On	-			-
8740	I	Room temp 1	-	0.0	50.0	°C
8741	I	Room setpoint 1	-	4.0	35.0	°C
8742	O	Room temp 1 model	-	0.0	50.0	°C
8743	I	Flow temp 1	-	0.0	140.0	°C
8744	I	Flow temp setpoint 1	-	0.0	140.0	°C
8760	I	Heating circuit pump Q6 Off ; On	-			-
8761	I	Heat circ mix valve op Y5 Off ; On	-			-
8762	I	Heat circ mix valve cl Y6 Off ; On	-			-
8770	I	Room temp 2	-	0.0	50.0	°C
8771	I	Room setpoint 2	-	4.0	35.0	°C
8772	O	Room temp 2 model	-	0.0	50.0	°C
8773	I	Flow temp 2	-	0.0	140.0	°C
8774	I	Flow temp setpoint 2	-	0.0	140.0	°C
8800	I	Room temp P	-	0.0	50.0	°C
8801	I	Room setpoint P	-	4.0	35.0	°C
8802	O	Room temp P model	-	0.0	50.0	°C
8803	I	Flow temp setpoint P	-	0.0	140.0	°C
8820	I	DHW pump Q3 Off ; On	-			-
8830	I	DHW temp 1	-	0.0	140.0	°C
8831	I	DHW temp setpoint	-	8.0	80.0	°C
8832	I	DHW temp 2	-	0.0	140.0	°C
8835	I	DHW circulation temp	-	0.0	140.0	°C
8930	I	Primary controller temp	-	0.0	140.0	°C
8931	I	Primary controller setpoint	-	0.0	140.0	°C
8950	I	Common flow temp	-	0.0	140.0	°C
8951	I	Common flow temperature setpoint	-	0.0	140.0	°C
9000	I	Flow temp setpoint H1	-	5.0	130.0	°C
9001	I	Flow temp setpoint H2	-	5.0	130.0	°C
9031	I	Relay output QX1 Off ; On	-			-
9050	I	Relay output QX21 module 1 Off ; On	-			-
9051	I	Relay output QX22 module 1 Off ; On	-			-
9052	I	Relay output QX23 module 1 Off ; On	-			-
9053	I	Relay output QX21 module 2 Off ; On	-			-
9054	I	Relay output QX22 module 2 Off ; On	-			-
9055	I	Relay output QX23 module 2 Off ; On	-			-

2 The settings in detail

2.1 Operator section

Operation and display

Line no.	Operating line
30	Data:read No Yes
31	Data:write No Yes

Data:read

The setting data of all operating levels are copied from the controller to the memory of the operator unit. This means that previous data in the operator unit will be overwritten.

Data:write

With the exception of the data listed below, the setting data of all operating levels are transferred from the memory of the operator unit to the connected controller. Previous setting data in the controller will be overwritten.



The following data will not be overwritten:

Line no.	Operating line
3	Year
130	Room unit 1
131	Room unit 2
132	Outside sensor
133	Repeater
134	Operator unit
135	Service unit
138	Delete all devices
516	default values
536	default values
556	default values
576	default values
6222	Device hours run
6600	device address
6601	Segment address
6650	Outside temp source

2.2 Heating circuits

mixing valve control

Line no.				Operating line
HC1	HC2	HC3P		
835	1135			Mixing valve Xp
836	1136			Mixing valve Tn

Mixing valve Xp

The proportional band defines within which change of the control variable Δx (ΔT of the flow) the whole correcting span y (valve travel) is traversed. The smaller the proportional band, the greater the change of the manipulated variable Δy at a given change of the controlled variable Δx .

Mixing valve Tn

The integral action time is the period of time the controller's I-part would require to produce the same change of the manipulated variable as the P-part

An adjustment of the integral action time changes the valve's rate of response. The longer the integral action time T_n , the slower the response of the controlled system.

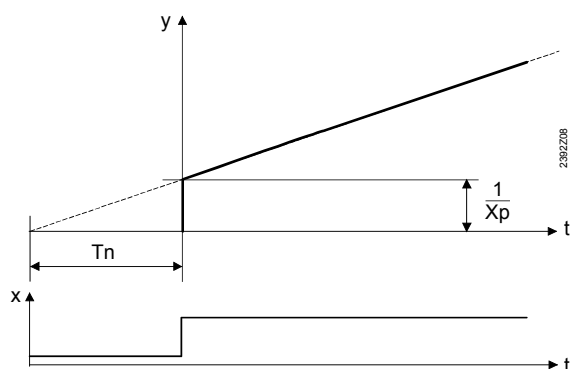

2.3 Domestic hot water

Setpoints

Line no.	Operating line
1614	Nominal setpoint max

This operating line is used to limit the "Nominal setpoint" (operating line 1610) at the top.

Release

Line no.	Operating line
1620	Release 24h/day Time programs HCs Time program 4 / DHW

24h/day

The DHW temperature is constantly maintained at the nominal DHW setpoint, independent of any time programs.

Example:

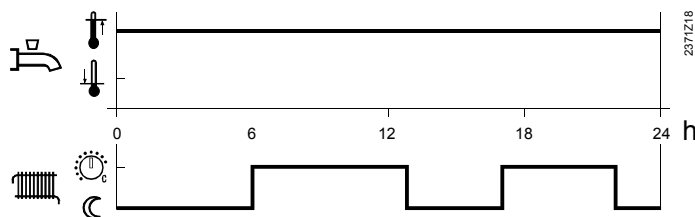

Time programs HCs

The DHW setpoint is switched between the nominal DHW setpoint and the reduced DHW setpoint according to the heating circuits' time programs. The first switch-on point of each period is shifted forward in time by one hour.

Example:

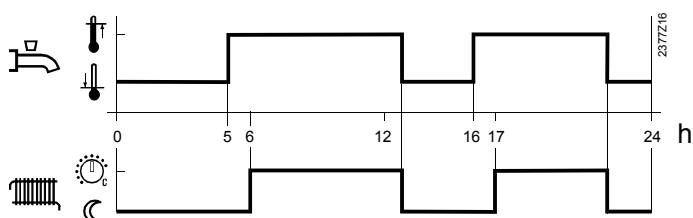

Time program 4 / DHW

For DHW heating, time switch program 4 of the local controller is used. The set switching times of that program are used to switch between the nominal DHW setpoint and the reduced DHW setpoint. This way, the DHW is heated independently of the heating circuits.

Example:

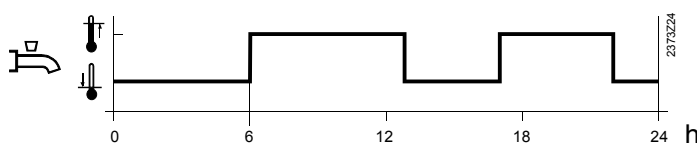

2.4 Pump H1/H2

pump H1

Line no.		Operating line
H1	H2	
2008	2033	H1/H2 DHW charging priority
		Off On

H1/H2 DHW charging priority

When using this setting, the connected pump H1/H2 can be excluded from / included in the effect of DHW charging priority.

In the case of a ventilation system, for example, it is thus possible to ensure a constant supply of heat with no impact from DHW charging priority.

2.5 Primary controller / system pump

flow temperature setpoint limitations

Line no.	Operating line
2110	Flow temp setpoint min
2111	Flow temp setpoint max

Using this limitation, a temperature range for the flow temperature setpoint can be defined. If the requested flow temperature setpoint reaches the relevant limit and the heat request increases or decreases, the flow temperature setpoint will be maintained at the maximum or minimum limit.

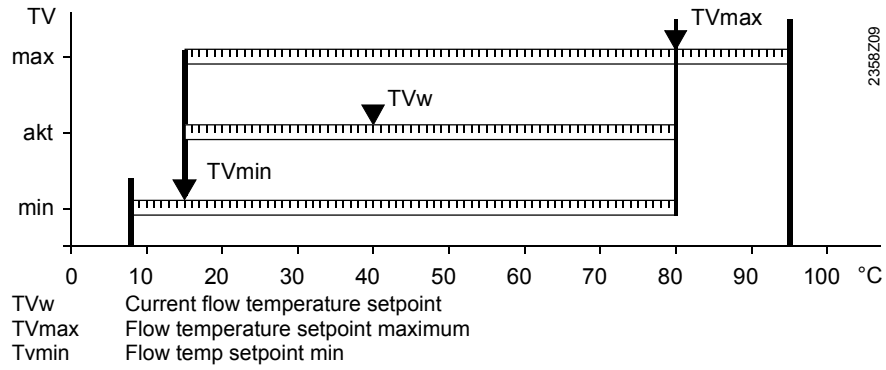

mixing valve control

Line no.	Operating line
2130	Mixing valve boost
2132	Actuator type
2133	Switching differential 2-pos
2134	Actuator running time
2135	Mixing valve Xp
2136	Mixing valve Tn

Mixing valve boost

For mixing, the actual value of the boiler flow temperature must be higher than the required setpoint of the mixing valve flow temperature since otherwise that temperature cannot be controlled. The controller generates the boiler temperature setpoint based on the increase set here and the current flow temperature setpoint.

Actuator: type

Selection of the type of actuator determines the way the control action impacts the type of mixing valve actuator used.

Switching differential 2-pos

For the 2-position actuator, the 2-position switching differential must also be adapted. This is not required when using 3-position actuators.

Actuator: running time

Setting the actuator running time for the mixing valve used.

Mixing valve Xp

The proportional band defines within which change of the control variable Δx (ΔT of the flow) the whole correcting span y (valve travel) is traversed. The smaller the proportional band, the greater the change of the manipulated variable Δy at a given change of the controlled variable Δx .

Mixing valve Tn

The integral action time is the period of time the controller's I-part would require to produce the same change of the manipulated variable as the P-part. An adjustment of the integral action time changes the valve's rate of response. The longer the integral action time T_n , the slower the response of the controlled system.

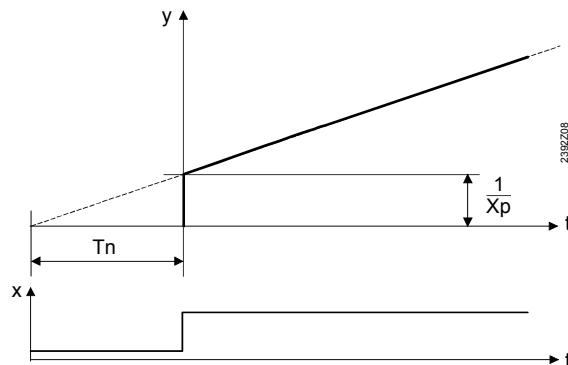

2.6 DHW storage tank

Release

Line no.	Operating line
5010	Charging Once / day Several times / day

Charging

Selection of charging “Once/day” or “Several times/day” is active only if DHW release is set according to the time programs of the heating circuits.

Once / day

Release of DHW charging is given 2.5 hours before the first heat request from the heating circuit is received. Then, the reduced DHW setpoint applies for the whole day.

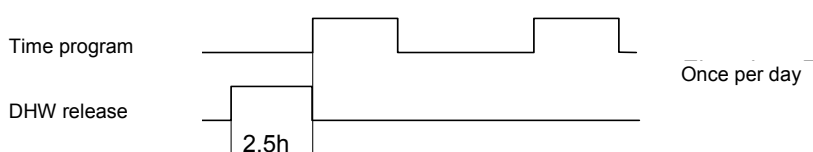

In the case of continuous heating (with no setback periods), release of DHW charging is given at 0:00. The same rule also applies if the first request for heat from the heating circuit is received before 02:30. If a request for heat is delivered at midnight, DHW charging is released after the first setback period, but no earlier than 2.5 hours before midnight.

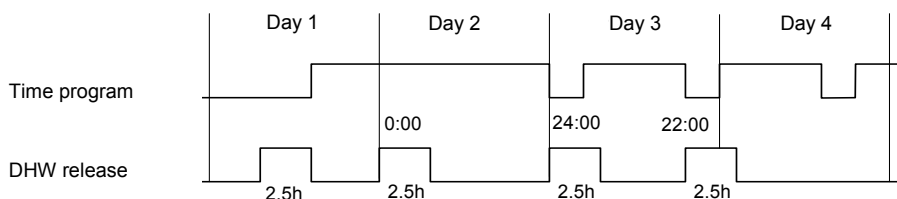

Several times / day

When selecting “Several times/day”, release of DHW charging is put forward in time by 1 hour against the periods of time the heating circuit calls for heat, and is then maintained during these periods of time.

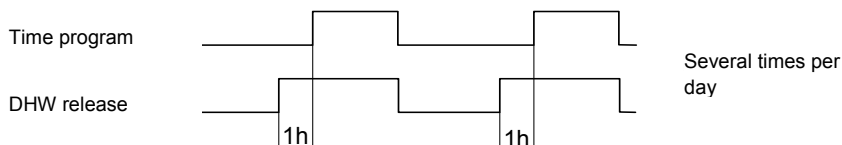

Charging control

Line no.	Operating line
5024	Switching diff

Switching diff

If the DHW temperature is lower than the current setpoint minus the switching differential set here, DHW charging will be started.

DHW charging will be terminated when the temperature reaches the current setpoint.



When DHW heating is released for the first time in a 24-hour period, forced charging will be initiated. DHW charging is also started when the DHW temperature lies within the switching differential, provided it does not lie less than 1 K below the setpoint.

Charging time limitation

<i>Line no.</i>	<i>Operating line</i>
5030	Charging time limitation

Charging time limitation

During DHW charging, space heating may obtain no or too little energy, depending on the selected charging priority (operating line 1630) and the type of hydraulic circuit. For this reason, it is often practical to set a time limit to DHW charging.

- - -

Charging time limitation is deactivated. The DHW is heated up to the nominal setpoint, even if space heating temporarily obtains too little heat.

10 – 600

DHW charging is stopped after the set period of time in minutes and then locked for the same time before it is resumed. During this period of time, the heat produced by the boiler is made available for space heating. This cycle is repeated until the nominal DHW setpoint is reached.



When space heating is switched off (summer operation, Eco function, etc.), DHW charging will not be stopped, independent of the selected setting.

Discharging protection

<i>Line no.</i>	<i>Operating line</i>
5040	Discharging protection

Discharging protection

This function ensures that the DHW charging pump (Q3) will be activated only when the boiler temperature is sufficiently high.

- **With sensor**
The charging pump will be activated only when the boiler temperature reaches the level of the DHW temperature plus half the charging boost. If, during charging, the boiler temperature drops to a level below the DHW temperature plus 1/8 the charging boost, the charging pump will be deactivated again. If 2 DHW sensors are parameterized for DHW charging, the lower temperature is used for the discharging protection function (usually sensor B31).
- **With thermostat**
The charging pump will be activated only when the boiler temperature lies above the nominal DHW setpoint. If, during charging, the boiler temperature drops below the nominal DHW temperature minus the DHW switching differential, the charging pump will be deactivated again.

Off

Function is deactivated.

Always

The function is always active.

Automatic

The function is active only if the heat source is unable to deliver heat, or is not available (fault, heat generation lock).

Overtemperature protection

Line no.	Operating line
5051	Storage tank temp max

Storage tank temp max

If the storage tank reaches the maximum storage tank temperature set here, the collector pump will be deactivated. It will be released again when the storage tank temperature drops 1 °C below the maximum storage tank temperature.



The protective collector overtemperature function can reactivate the collector pump until the storage tank's safety temperature is reached.

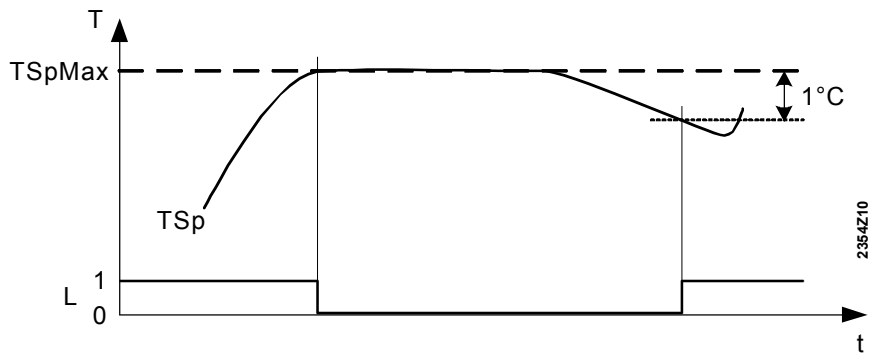

TSpMax Storage tank temp max (operating line 5051)
 TSp Actual value of the storage tank temperature
 L Storage tank charging: 1 = on, 0 = off

DHW push

Line no.	Operating line
5070	Automatic push Off On

Automatic push

The DHW push can be triggered either manually or automatically. With the DHW push, the DHW is heated up once until the nominal setpoint is reached.

Off

The DHW push must be triggered manually.

On

If the DHW temperature falls below the reduced setpoint (operating line 1612) by at least 2 switching differentials (operating line 5024), one-time charging to the nominal DHW setpoint (operating line 1610) will take place again.



The automatic DHW push only works when the DHW operating mode is activated.

2.7 Configuration

Building and room model

Line no.	Operating line
6112	Gradient room model

Gradient room model

The room model gradient gives the period of time in minutes room heating needs to raise the temperature by 1 °C. The setting made applies to all circuits.

The setting is used to calculate the fictive room temperature of rooms that have no room temperature sensor installed (operating lines 8742, 8772, and 8802).

Parameters

<i>Line no.</i>	<i>Operating line</i>
6204	Save parameters

The current parameter settings can be saved as new standard settings. Exempted from this are the following operating pages: Time of day and date, operator section, wireless, and all time programs, as well as the number of operating hours and the different counters.



Important:

With this process, the factory settings will be overwritten and can no longer be retrieved!

<i>Line no.</i>	<i>Operating line</i>
6222	Device hours run

Device hours run

This indicates the total number of operating hours since the controller was first commissioned.

2.8 LPB

Error / maintenance / alarms

<i>Line no.</i>	<i>Operating line</i>
6610	Display system messages
6612	Alarm delay
6620	Action changeover functions Segment System

Display system messages

This setting enables system messages transmitted via LPB to be suppressed at the connected operator unit.

Alarm delay

Delivery of the alarm to the OCI can be delayed in the basic unit by setting a delay. This ensures that unnecessary notifications of a service center resulting from short-time errors (e.g. temperature limiter cut out, communication error) can be prevented. It is to be noted, however, that errors occurring for a short period of time, and reoccurring constantly and rapidly, will also be filtered.

Range of action of changeover

The range of action of central changeover can be defined.

This applies to the following types of limitation:

- Optg mode changeover
- Summer changeover (when selecting "Central" on setting line 6621)

Entries:

- Segment: Changeover takes place with all controllers in the same segment.
- System: Changeover takes place with all controllers in the entire system (in all segments). The controller must be located in segment 0!

2.9 Error

History 1...10

<i>Line no.</i>	<i>Operating line</i>
6820	Reset history No Yes

Reset history

The error history with the last 10 errors will be deleted.

2.10 Diagnostics consumers

Heating circuit 1, heating circuit 2, heating circuit P

<i>Line no.</i>	<i>Operating line</i>
8742	Room temp 1 model
8772	Room temp 2 model
8802	Room temp P model

Room temperature 1 / 2 / P model

The room model calculates a fictive room temperature for rooms that have no room temperature sensor. The value calculated for each heating circuit is indicated on these operating lines.

This allows boost heating, quick setback and optimum start and stop control to be implemented with no need for using a room temperature sensor.

The calculation takes into account the attenuated outside temperature (operating line 8703), the room model gradient (operating line 6112) for switching to a higher setpoint, and the building's time constant (operating line 6110) for switching to a lower setpoint.

Index

A	
action changeover functions.....	22
attenuated outside temperature	23
Automatic push.....	21
B	
building's time constant	23
C	
charging DHW	19
Charging time limitation.....	20
copy settings	15
D	
Data:read.....	15
Data:write	15
Device hours run	22
DHW charging	19
DHW push	21
DHW switching differential	19
E	
error reset.....	23
F	
flow temp setpoint max.....	17
flow temp setpoint min.....	17
G	
Gradient room model.....	21, 23
H	
history reset.....	23
hours run device.....	22
I	
integral action time	16, 18
L	
limitation of charging time.....	20
M	
maximum nominal setpoint.....	16
model room temperature 1 / 2 / P.....	23
N	
Nominal setpoint max	16
O	
once / day	19
Optimum start control	23
optimum stop control	23
P	
proportional band.....	15, 18
push.....	21
Q	
quick setback / boost heating	23
R	
reset	
error history	23
room model gradient.....	21
room temperature model 1 / 2 / P.....	23
S	
Save parameters	22
Saving parameter settings.....	22
several times / day.....	19
Summer changeover	22
switching differential DHW.....	19

3 Proof of change

All changes since the last issue (see front side) are registered in the original document (Winwordfile) with the Winwordfunktion " Highlight ".

To make these passages visible, go forward with the following key combination:

Show: Ctrl+Shift+'`

Hide: Ctrl+Shift+'`

Or put the same functionality about the following Winword menu:

Menu: [Tools] - [Optionen]

Option: [Highlight]



In the Printfile (PDF) the change proof is not evident.'

Siemens Schweiz AG
Siemens Switzerland Ltd
Building Technologies Group / HVAC Products
Gubelstrasse 22
CH -6301 Zug
Tel. +41 41-724 24 24
Fax +41 41-724 35 22
www.sbt.siemens.com

© 2005-2006 Siemens Building Technologies AG
Subject to alteration