



# Hardware Integration Guide

**AirPrime HL8548**



**SIERRA**  
WIRELESS®

4119996  
1.3  
April 10, 2017

## Important Notice

Due to the nature of wireless communications, transmission and reception of data can never be guaranteed. Data may be delayed, corrupted (i.e., have errors) or be totally lost. Although significant delays or losses of data are rare when wireless devices such as the Sierra Wireless modem are used in a normal manner with a well-constructed network, the Sierra Wireless modem should not be used in situations where failure to transmit or receive data could result in damage of any kind to the user or any other party, including but not limited to personal injury, death, or loss of property. Sierra Wireless accepts no responsibility for damages of any kind resulting from delays or errors in data transmitted or received using the Sierra Wireless modem, or for failure of the Sierra Wireless modem to transmit or receive such data.

## Safety and Hazards

Do not operate the Sierra Wireless modem in areas where cellular modems are not advised without proper device certifications. These areas include environments where cellular radio can interfere such as explosive atmospheres, medical equipment, or any other equipment which may be susceptible to any form of radio interference. The Sierra Wireless modem can transmit signals that could interfere with this equipment. Do not operate the Sierra Wireless modem in any aircraft, whether the aircraft is on the ground or in flight. In aircraft, the Sierra Wireless modem **MUST BE POWERED OFF**. When operating, the Sierra Wireless modem can transmit signals that could interfere with various onboard systems.

---

*Note: Some airlines may permit the use of cellular phones while the aircraft is on the ground and the door is open. Sierra Wireless modems may be used at this time.*

---

The driver or operator of any vehicle should not operate the Sierra Wireless modem while in control of a vehicle. Doing so will detract from the driver or operator's control and operation of that vehicle. In some states and provinces, operating such communications devices while in control of a vehicle is an offence.

## Limitations of Liability

This manual is provided "as is". Sierra Wireless makes no warranties of any kind, either expressed or implied, including any implied warranties of merchantability, fitness for a particular purpose, or noninfringement. The recipient of the manual shall endorse all risks arising from its use.

The information in this manual is subject to change without notice and does not represent a commitment on the part of Sierra Wireless. SIERRA WIRELESS AND ITS AFFILIATES SPECIFICALLY DISCLAIM LIABILITY FOR ANY AND ALL DIRECT, INDIRECT, SPECIAL, GENERAL, INCIDENTAL, CONSEQUENTIAL, PUNITIVE OR EXEMPLARY DAMAGES INCLUDING, BUT NOT LIMITED TO, LOSS OF PROFITS OR REVENUE OR ANTICIPATED PROFITS OR REVENUE ARISING OUT OF THE USE OR INABILITY TO USE ANY SIERRA WIRELESS PRODUCT, EVEN IF SIERRA WIRELESS AND/OR ITS AFFILIATES HAS BEEN ADVISED OF THE POSSIBILITY OF SUCH DAMAGES OR THEY ARE FORESEEABLE OR FOR CLAIMS BY ANY THIRD PARTY.

Notwithstanding the foregoing, in no event shall Sierra Wireless and/or its affiliates aggregate liability arising under or in connection with the Sierra Wireless product, regardless of the number of events, occurrences, or claims giving rise to liability, be in excess of the price paid by the purchaser for the Sierra Wireless product.

## Patents

This product may contain technology developed by or for Sierra Wireless Inc.

This product includes technology licensed from QUALCOMM®.

This product is manufactured or sold by Sierra Wireless Inc. or its affiliates under one or more patents licensed from InterDigital Group and MMP Portfolio Licensing.

## Copyright

© 2016 Sierra Wireless. All rights reserved.

## Trademarks

Sierra Wireless®, AirPrime®, AirLink®, AirVantage®, WISMO®, ALEOS® and the Sierra Wireless and Open AT logos are registered trademarks of Sierra Wireless, Inc. or one of its subsidiaries.

Watcher® is a registered trademark of NETGEAR, Inc., used under license.

Windows® and Windows Vista® are registered trademarks of Microsoft Corporation.

Macintosh® and Mac OS X® are registered trademarks of Apple Inc., registered in the U.S. and other countries.

QUALCOMM® is a registered trademark of QUALCOMM Incorporated. Used under license.

Other trademarks are the property of their respective owners.

## Contact Information

Sales information and technical support, including warranty and returns	Web: <a href="http://sierrawireless.com/company/contact-us/">sierrawireless.com/company/contact-us/</a> Global toll-free number: 1-877-687-7795 6:00 am to 6:00 pm PST
Corporate and product information	Web: <a href="http://sierrawireless.com">sierrawireless.com</a>

# Document History

Version	Date	Updates
1.0	September 29, 2016	Creation
1.1	October 14, 2016	Updated to match with the data in the HL8548 PTS
1.2	October 24, 2016	Updated 5.2 IC Regulations
1.3	April 10, 2017	Updated antenna gain for FCC/IC



# Contents

<b>1. INTRODUCTION .....</b>	<b>8</b>
<b>2. POWER INTERFACE.....</b>	<b>9</b>
2.1. Power Supply .....	9
2.2. Power Off Sequence .....	9
2.3. Sleep Mode Management .....	9
<b>3. RF INTERFACE.....</b>	<b>10</b>
3.1. Supported RF Bands .....	10
3.2. RF Connection.....	10
3.2.1. Choosing the Correct Antenna and Cabling .....	11
3.2.2. Designing Custom Antennas .....	11
3.2.3. Determining the Antenna's Location .....	11
3.3. RF Performances .....	11
<b>4. ESD GUIDELINES.....</b>	<b>12</b>
4.1. SIM Card .....	12
4.2. USB .....	13
<b>5. LEGAL INFORMATION .....</b>	<b>14</b>
5.1. FCC Regulations .....	14
5.2. IC Regulations .....	16
5.2.1. Radiation Exposure Statement .....	16
<b>6. REFERENCES .....</b>	<b>17</b>
6.1. Reference Documents.....	17
6.2. Terms and Abbreviations.....	17



## List of Figures

Figure 1.	EMC and ESD Components Close to the SIM.....	12
Figure 2.	ESD Protection for USB .....	13



# List of Tables

Table 1.	Power Supply .....	9
Table 2.	Supported Bands.....	10
Table 3.	Conducted RX Sensitivity (dBm) .....	11
Table 4.	Approved Antenna Types.....	16



# 1. Introduction

The AirPrime HL8548 belongs to the AirPrime MC Series product family and provides data connectivity on wireless networks (as listed in Table 2 Supported Bands).

The HL8548 supports a large variety of interfaces such as USB 2.0, UART, GPIOs and SIM to provide customers with the highest level of flexibility in implementing high-end solutions.



## 2. Power Interface

### 2.1. Power Supply

The AirPrime HL8548 is supplied through the VBAT signal.

Table 1. Power Supply

Pin Numbers	Supply	Minimum	Typical	Maximum
2, 24, 39, 41, 52	VBAT voltage (V)	3.2*	3.7	4.5

\* This value has to be guaranteed during the burst

---

*Note:* Load capacitance for VBAT is around  $30\mu\text{F} \pm 20\%$  embedded inside the accessory board.

---

### 2.2. Power Off Sequence

To power the HL8548 off:

1. Put the accessory board in low power mode (LPM) by sending either **AT+KSLEEP=1** or **AT+CPWROFF=1**.
2. Wait for at least 10 seconds.
3. Remove the power supply to VBAT.

### 2.3. Sleep Mode Management

Use **AT+KSLEEP=1** to allow the accessory board to automatically enter sleep mode while the USB interface is in use.

When **AT+KSLEEP=2**, the accessory board will never enter sleep mode.



## 3. RF Interface

The RF interface of the HL8548 allows transmission of RF signals. This interface has a 50Ω nominal impedance.

### 3.1. Supported RF Bands

The AirPrime HL8548 supports the RF bands listed in the table below.

Table 2. Supported Bands

RF Band	Transmit band (Tx)	Receive band (Rx)	Maximum Output Power
UMTS B1	1922 to 1978 MHz	2112 to 2168 MHz	23 dBm (+/- 2dBm) Class 3bis
UMTS B2	1852 to 1908 MHz	1932 to 1988 MHz	23 dBm (+/- 2dBm) Class 3bis
UMTS B5	826 to 847 MHz	871 to 892 MHz	23 dBm (+/- 2dBm) Class 3bis
UMTS B6	832 to 838 MHz	877 to 883 MHz	23 dBm (+/- 2dBm) Class 3bis
UMTS B8	882 to 913 MHz	927 to 958 MHz	23 dBm (+/- 2dBm) Class 3bis
UMTS B19	832.4 to 842.6 MHz	877.4 to 887.6 MHz	23 dBm (+/- 2dBm) Class 3bis
GSM 850	824 to 849 MHz	869 to 894 MHz	2 Watts GSM, GPRS and EDGE
E-GSM 900	880 to 915 MHz	925 to 960 MHz	2 Watts GSM, GPRS and EDGE
DCS 1800	1710 to 1785 MHz	1805 to 1880 MHz	1 Watt GSM, GPRS and EDGE
PCS 1900	1850 to 1910 MHz	1930 to 1990 MHz	1 Watt GSM, GPRS and EDGE

### 3.2. RF Connection

When attaching antennas to the HL8548:

- Use Hirose U.FL connectors (3 mm x 3 mm, low profile; model U.FL #CL331-0471-0-10) to attach antennas to connection points on the Accessory Board.

---

*Note:* To disconnect the antenna, make sure you use the Hirose U.FL connector removal tool (P/N UFL-LP-N-2(01)) to prevent damage to the Accessory Board or coaxial cable assembly.

---

- Match coaxial connections between the Accessory Board and the antenna to 50Ω.
- Minimize RF cable losses to the antenna; the recommended maximum cable loss for antenna cabling is 0.5 dB.
- To ensure best thermal performance, mounting holes must be used to attach (ground) the device to the main PCB ground or a metal chassis.

---

*Note:* If the antenna connection is shorted or open, the HL8548 will not sustain permanent damage.

---

### 3.2.1. Choosing the Correct Antenna and Cabling

When matching antennas and cabling:

- The antenna (and associated circuitry) should have a nominal impedance of 50Ω with a recommended return loss of better than 10 dB across each frequency band of operation.
- The system gain value affects both radiated power and regulatory (FCC, IC, etc.) test results.

### 3.2.2. Designing Custom Antennas

Note that in designing custom antennas, a skilled RF engineer should do the development to ensure that the RF performance is maintained.

### 3.2.3. Determining the Antenna's Location

When deciding where to put the antennas:

- Antenna location may affect RF performance. Although the Accessory Board is shielded to prevent interference in most applications, the placement of the antenna is still very important - if the host device is insufficiently shielded, high levels of broadband noise or spurious interferences can degrade the HL8548's performance.
- Connecting cables between the Accessory Board and the antenna must have 50Ω impedance. If the impedance of the Accessory Board is mismatched, RF performance is reduced significantly.
- Antenna cables should be routed, if possible, away from noise sources (switching power supplies, LCD assemblies, etc.). If the cables are near the noise sources, the noise may be coupled into the RF cable and into the antenna.

## 3.3. RF Performances

RF performances are compliant with the ETSI recommendation GSM 05.05.

---

*Note: Values in the table below are preliminary and subject to change.*

---

Table 3. Conducted RX Sensitivity (dBm)

Frequency Band	Typical Sensitivity (dBm)
GSM850/EGSM	-109
DCS/PCS	-108
UMTS B1	-110
UMTS B2	-110
UMTS B5/6	-110
UMTS B8	-110

# 4. ESD Guidelines

## 4.1. SIM Card

Decoupling capacitors must be added according to the drawings below as close as possible to the SIM card connectors on UIM1\_CLK, UIM1\_RST, UIM1\_VCC and UIM1\_DATA signals to avoid EMC issues and to comply with the requirements of ETSI and 3GPP standards covering the SIM electrical interface.

A typical schematic including SIM detection is provided below.

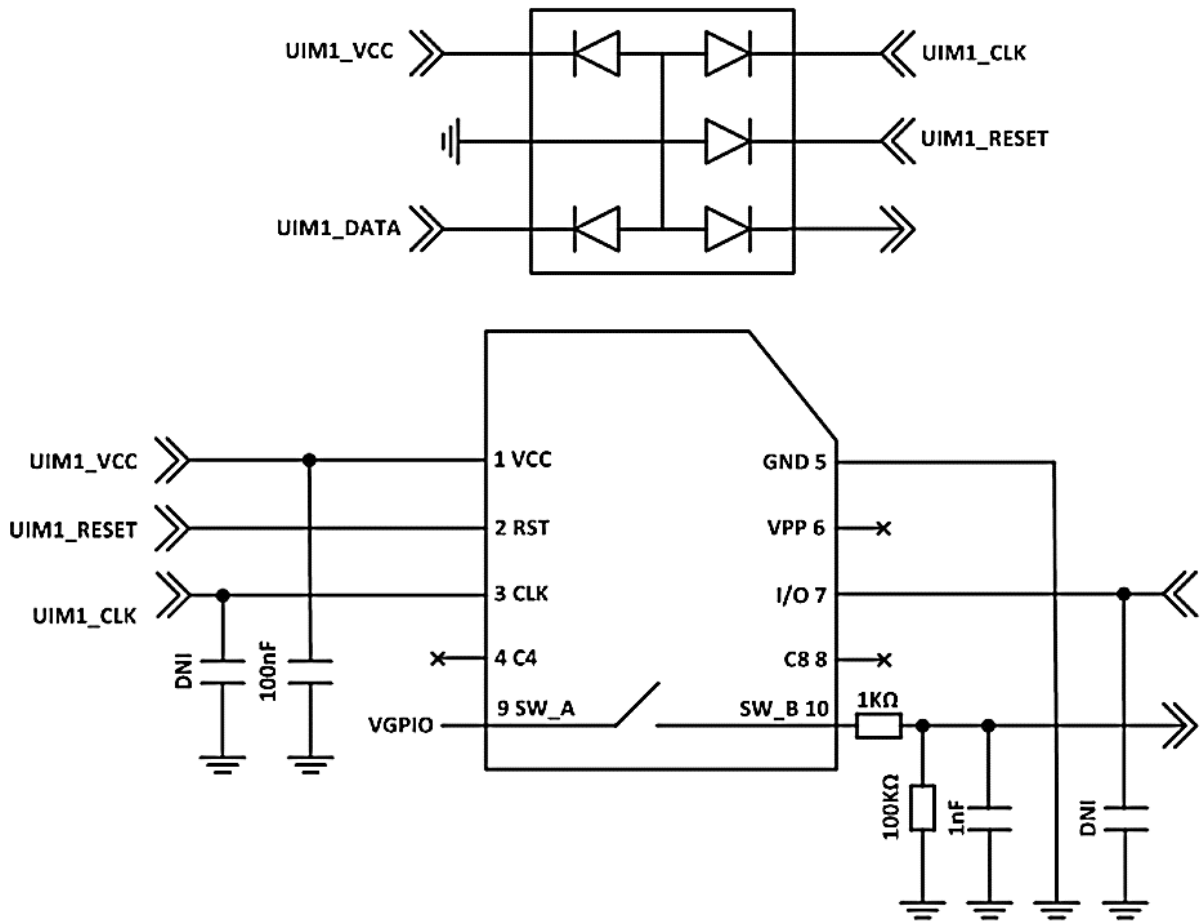

Figure 1. EMC and ESD Components Close to the SIM

## 4.2. USB

When the USB interface is externally accessible, it is required to have ESD protection on the USB\_D+ and USB\_D- signals.

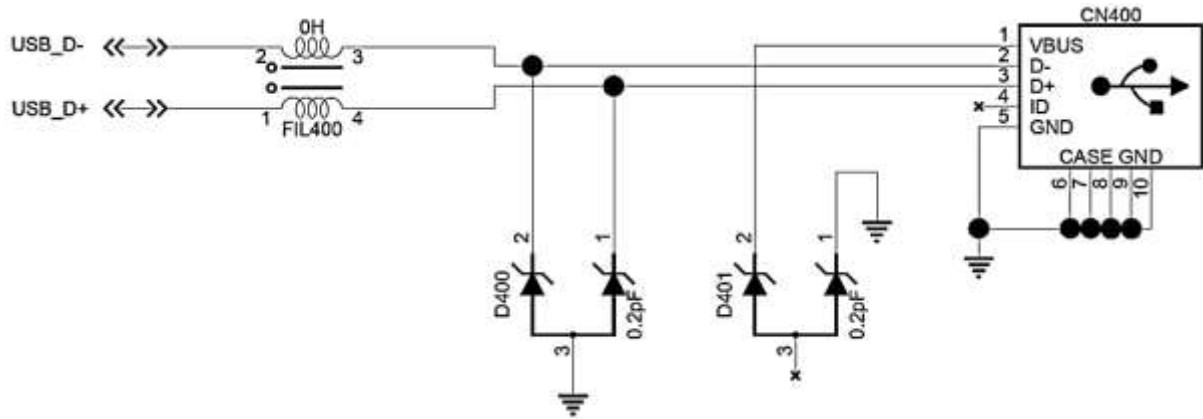

Figure 2. ESD Protection for USB

Sierra Wireless recommends using a 90Ω DLP0NSN900HL2L EMC filter and an RCLAMP0503N or ESD5V3U2U-03LRH ESD diode.



## 5. Legal Information

### 5.1. FCC Regulations

The HL8548 has been granted modular approval for mobile applications. Integrators may use the HL8548 in their final products without additional FCC certification if they meet the following conditions. Otherwise, additional FCC approvals must be obtained.

1. At least 20 cm separation distance between the antenna and the user's body must be maintained at all times.
2. To comply with FCC regulations limiting both maximum RF output power and human exposure to RF radiation, the maximum antenna gain including cable loss in a mobile-only exposure condition must not exceed:
  - 3.0 dBi in the cellular band
  - 5.0 dBi in the PCS band
3. The HL8548 may transmit simultaneously with other collocated radio transmitters within a host device, provided the following conditions are met:
  - Each collocated radio transmitter has been certified by FCC for mobile application.
  - At least 20 cm separation distance between the antennas of the collocated transmitters and the user's body must be maintained at all times.
  - The output power and antenna gain must not exceed the limits and configurations stipulated in the following table.

Device	Technology	Frequency (MHz)	Maximum Antenna Gain (dBi)		EIRP Limits (dBm)
			Standalone	Collocated	
HL8548	GPRS/EDGE 850	824-849	3	3	-
	GPRS/EDGE 1900	1850-1910	5	5	-
	UMTS 850	824-849	3	3	-
	UMTS 1900	1850-1910	5	5	-
Collocated transmitters	WLAN	2400-2500	-	-	27
		5150-580	-	-	27
	WiMAX	2300-2400	-	-	27
		2500-2700	-	-	27
		3300-3800	-	-	27
	BT	2400-2500	-	-	20

- The RF signal must be routed on the application board using tracks with a  $50\Omega$  characteristic impedance. Basically, the characteristic impedance depends on the dielectric, the track width and the ground plane spacing. In order to respect this constraint, Sierra Wireless recommends using MicroStrip or StripLine structure and computing the Tracks width with a simulation tool (like AppCad shown in the figure below and that is available free of charge at <http://www.agilent.com>).

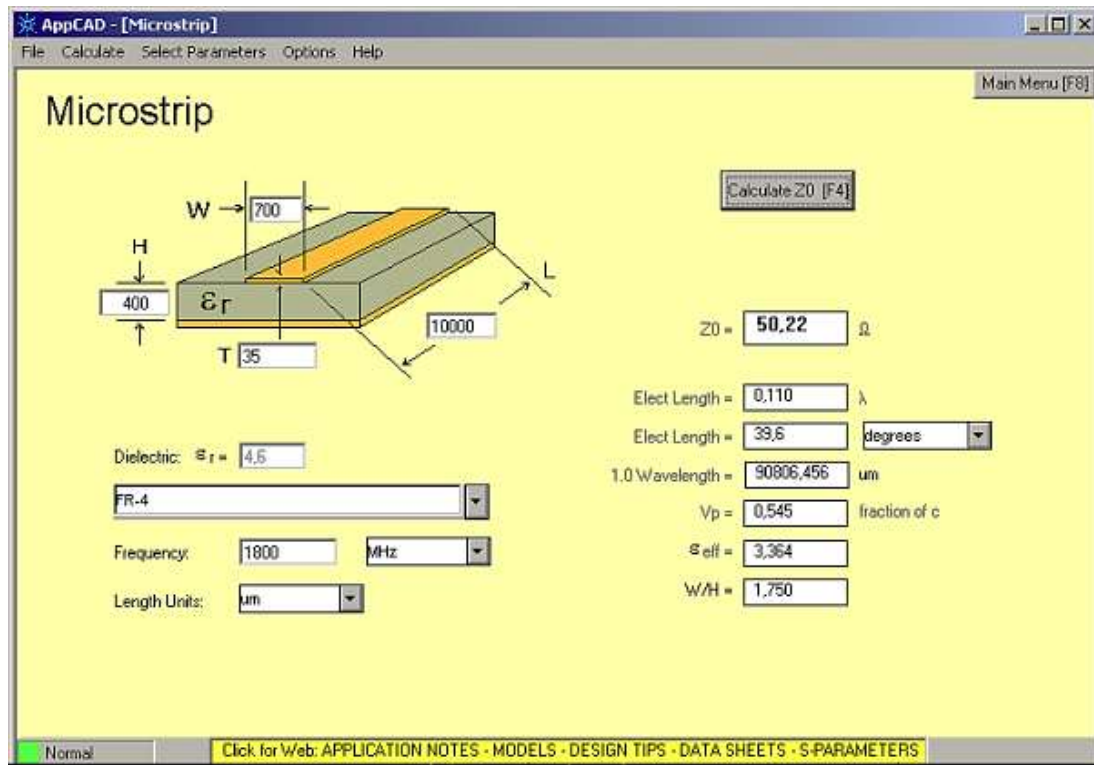

If a multi-layered PCB is used, the RF path on the board must not cross any signal (digital, analog or supply).

- A label must be affixed to the outside of the end product into which the HL8548 is incorporated, with a statement similar to the following:

This device contains FCC ID: **N7NHL8548**

- A user manual with the end product must clearly indicate the operating requirements and conditions that must be observed to ensure compliance with current FCC RF exposure guidelines.

The end product with an embedded HL8548 may also need to pass the FCC Part 15 unintentional emission testing requirements and be properly authorized per FCC Part 15.

---

*Note: If this accessory board is intended for use in a portable device, you are responsible for separate approval to satisfy the SAR requirements of FCC Part 2.1093.*

---

## 5.2. IC Regulations

This device complies with Industry Canada's license-exempt RSSs. Operation is subject to the following two conditions:

1. This device may not cause interference; and
2. This device must accept any interference, including interference that may cause undesired operation of the device.

Le présent appareil est conforme aux CNR d'Industrie Canada applicables aux appareils radio exempts de licence. L'exploitation est autorisée aux deux conditions suivantes:

1. l'appareil ne doit pas produire de brouillage;
2. l'utilisateur de l'appareil doit accepter tout brouillage radioélectrique subi, même si le brouillage est susceptible d'en compromettre le fonctionnement.

### 5.2.1. Radiation Exposure Statement

This equipment complies with Canada radiation exposure limits set forth for an uncontrolled environment.

This equipment should be installed and operated with minimum distance 20cm between the radiator and your body.

Cet équipement est conforme Canada limites d'exposition aux radiations dans un environnement non contrôlé.

Cet équipement doit être installé et utilisé à distance minimum de 20cm entre le radiateur et votre corps.

This radio transmitter (IC: **2417C-HL8548**) has been approved by Industry Canada to operate with the antenna types listed below with the maximum permissible gain indicated. Antenna types not included in this list, having a gain greater than the maximum gain indicated for that type, are strictly prohibited for use with this device.

Le présent émetteur radio (IC: **2417C-HL8548**) a été approuvé par Industrie Canada pour fonctionner avec les types d'antenne énumérés ci dessous et ayant un gain admissible maximal. Les types d'antenne non inclus dans cette liste, et dont le gain est supérieur au gain maximal indiqué, sont strictement interdits pour l'exploitation de l'émetteur.

Table 4. Approved Antenna Types

Type	Gain	Connector
Dipole	2 dBi	R-SMA





## 6. References

### 6.1. Reference Documents

- [1] AirPrime HL8548 and HL8548-G Product Technical Specification  
Reference Number: 4114663

### 6.2. Terms and Abbreviations

Abbreviation	Definition
ADC	Analog to Digital Converter
AGC	Automatic Gain Control
AT	Attention (prefix for modem commands)
CDMA	Code Division Multiple Access
CF3	Common Flexible Form Factor
CLK	Clock
CODEC	Coder Decoder
CPU	Central Processing Unit
DAC	Digital to Analog Converter
DTR	Data Terminal Ready
EGNOS	European Geostationary Navigation Overlay Service
EMC	Electromagnetic Compatibility
EMI	Electromagnetic Interference
EN	Enable
ESD	Electrostatic Discharges
ETSI	European Telecommunications Standards Institute
FDMA	Frequency-division multiple access
GAGAN	GPS aided geo augmented navigation
GLONASS	Global Navigation Satellite System
GND	Ground
GNSS	Global Navigation Satellite System
GPIO	General Purpose Input Output
GPRS	General Packet Radio Service
GSM	Global System for Mobile communications
Hi Z	High impedance (Z)
IC	Integrated Circuit
IMEI	International Mobile Equipment Identification
I/O	Input / Output
LED	Light Emitting Diode
LNA	Low Noise Amplifier
MAX	Maximum

Abbreviation	Definition
MIN	Minimum
MSAS	Multi-functional Satellite Augmentation System
N/A	Not Applicable
PA	Power Amplifier
PC	Personal Computer
PCB	Printed Circuit Board
PCL	Power Control Level
PLL	Phase Lock Loop
PWM	Pulse Width Modulation
QZSS	Quasi-Zenith Satellite System
RF	Radio Frequency
RFI	Radio Frequency Interference
RMS	Root Mean Square
RST	Reset
RTC	Real Time Clock
RX	Receive
SCL	Serial Clock
SDA	Serial Data
SIM	Subscriber Identification Module
SMD	Surface Mounted Device/Design
SPI	Serial Peripheral Interface
SW	Software
PSRAM	Pseudo Static RAM
TBC	To Be Confirmed
TBD	To Be Defined
TP	Test Point
TX	Transmit
TYP	Typical
UART	Universal Asynchronous Receiver-Transmitter
UICC	Universal Integrated Circuit Card
USB	Universal Serial Bus
UIM	User Identity Module
VBATT	Main Supply Voltage from Battery or DC adapter
VSWR	Voltage Standing Wave Ratio
WAAS	Wide Area Augmentation System