



# Getting Started

## HP Compaq Notebook Series

Document Part Number: [403067-001](#)

December 2005

This guide explains how to set up your hardware and software, and begin using the computer in Microsoft® Windows®.

© Copyright 2005 Hewlett-Packard Development Company, L.P.

Microsoft and Windows are U.S. registered trademarks of Microsoft Corporation. SD Logo is a trademark of its proprietor. Bluetooth is a trademark owned by its proprietor and used by Hewlett-Packard Company under license.

The information contained herein is subject to change without notice. The only warranties for HP products and services are set forth in the express warranty statements accompanying such products and services. Nothing herein should be construed as constituting an additional warranty. HP shall not be liable for technical or editorial errors or omissions contained herein.

Getting Started  
HP Compaq Notebook Series  
First Edition December 2005  
Document Part Number: 403067-001

---

# Contents

## 1 First-time setup

Identify hardware . . . . .	1-1
Computer hardware . . . . .	1-1
Top components . . . . .	1-2
Keys . . . . .	1-3
TouchPad . . . . .	1-4
Front components . . . . .	1-5
Rear components . . . . .	1-6
Right-side components . . . . .	1-6
Left-side components . . . . .	1-7
Bottom components . . . . .	1-8
Set up the computer . . . . .	1-9
Step 1: Insert the battery pack . . . . .	1-10
Step 2: Connect the computer to external power. . .	1-11
Step 3: Turn on the computer . . . . .	1-13
Step 4: Set up the software . . . . .	1-15

## 2 Next steps

Install additional hardware and software . . . . .	2-1
Protect the computer . . . . .	2-1
Protect the computer from viruses . . . . .	2-1
Protect your system files . . . . .	2-2
Protect your privacy . . . . .	2-2
Protect the computer from power surges . . . . .	2-3
Use the computer safely . . . . .	2-3
Connect to a computer network . . . . .	2-5

Update your software . . . . .	2-6
Locate the user guides . . . . .	2-6
Turn off the computer correctly . . . . .	2-7

### **3 Troubleshooting**

Troubleshooting resources . . . . .	3-1
Quick troubleshooting . . . . .	3-2
Is the computer unable to start up? . . . . .	3-2
Is the computer screen blank? . . . . .	3-3
Is software functioning abnormally? . . . . .	3-4
Is the computer unresponsive? . . . . .	3-5
Is the computer overheating? . . . . .	3-6
Is an external device not working? . . . . .	3-7
Help and Support Center . . . . .	3-8
Customer Care . . . . .	3-9
Preparing to contact Customer Care . . . . .	3-9
Contacting Customer Care by e-mail or telephone . . . . .	3-10

### **A Specifications**

Operating Environment . . . . .	A-1
Rated Input Power . . . . .	A-2

### **B System recovery**

Safeguarding your data . . . . .	B-1
Using Altiris Local Recovery (select models only) . . . . .	B-1
Using System Restore points . . . . .	B-2
Creating a System Restore Point . . . . .	B-3
Restoring to a restore point . . . . .	B-3
Reinstalling applications . . . . .	B-3
Reinstalling applications from the hard drive . . . . .	B-4
Reinstalling applications from discs . . . . .	B-4
Repairing the operating system . . . . .	B-5
Reinstalling the operating system . . . . .	B-6
Reinstalling device drivers and other software . . . . .	B-7

## **C Connect to the Internet from your home**

Choose an ISP .....	C-1
Using the Internet Connection Wizard .....	C-2
Choose the type of Internet access.....	C-3

## **Index**

*Contents*

---

# 1

---

## First-time setup

### Identify hardware

#### Computer hardware



---

#### Component

- 
- ❶ AC adapter

---

  - ❷ Power cord

---

  - ❸ Primary battery pack

---

  - ❹ Modem cable
-

## Top components

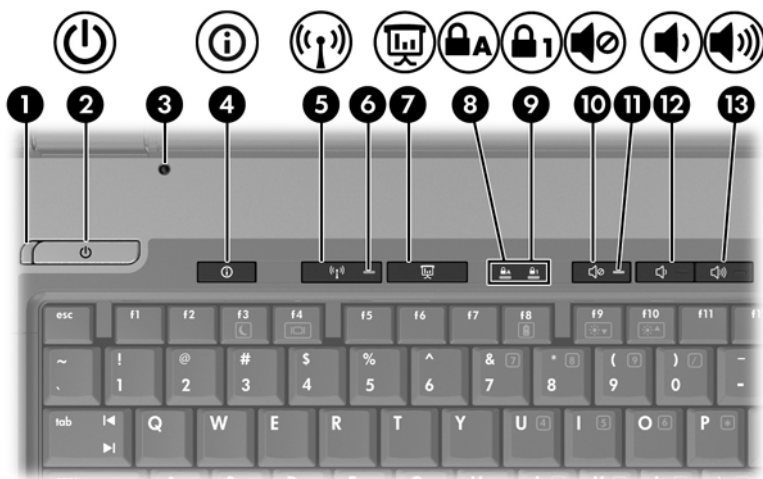

### Component

❶ Power light	❸ Caps lock light
❷ Power button	❹ Num lock light
❸ Display switch	❺ Volume mute button
❹ Info Center button	❻ Volume mute light
❺ Wireless button	❼ Volume down button
❻ Wireless light	❽ Volume up button
❼ Presentation mode button	



## Keys

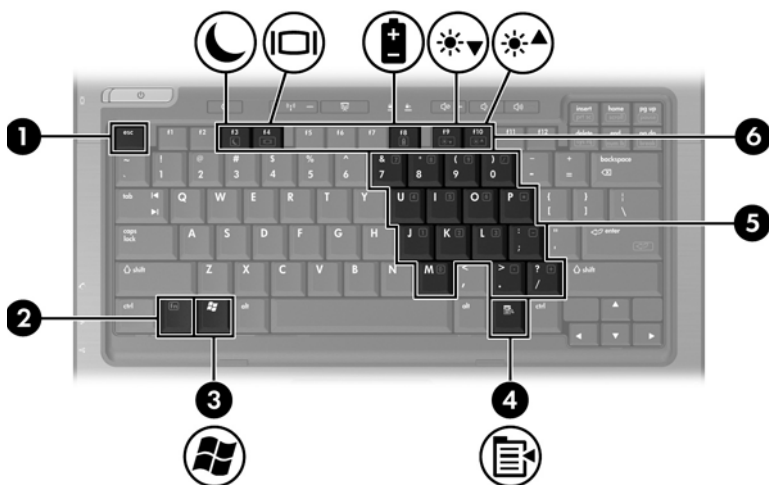

---

### Component

---

❶	esc key	❷	Windows applications key
❸	fn key	❸	Embedded numeric keypad keys
❹	Windows logo key	❹	Function keys

---

## TouchPad

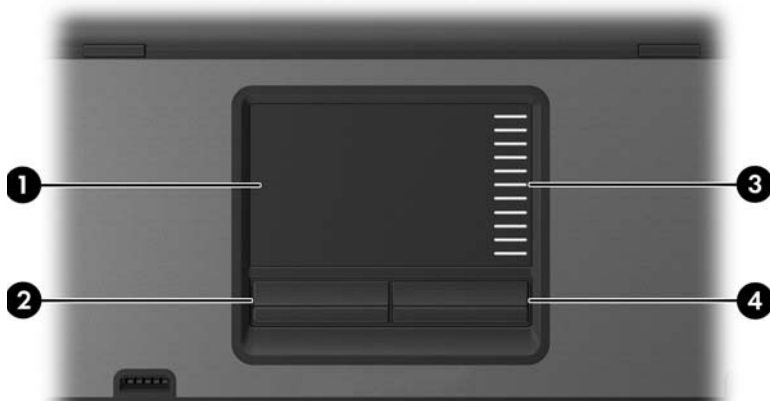

---

### Component

---

❶ TouchPad	❸ TouchPad scroll zone
❷ Left TouchPad button	❹ Right TouchPad button

---

## Front components

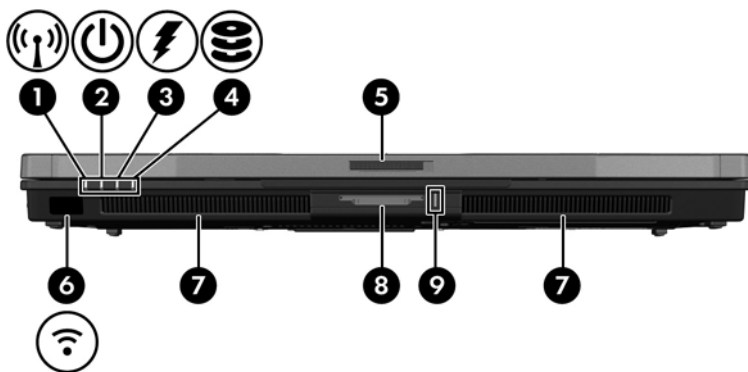

### Component

❶	Wireless light	❸	Infrared port
❷	Power light	❹	Speakers (2)
❸	Battery light	❺	6-in-1 Digital Media Slot
❹	IDE (Integrated Drive Electronics) drive light	❻	6-in-1 Digital Media Slot light
❺	Display release latch		

## Rear components



Component	
❶ Security cable slot	❸ Parallel port
❷ Power connector	❹ S-Video-out jack

## Right-side components

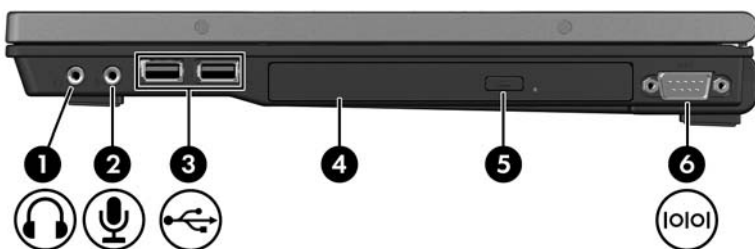

Component	
❶ Audio-out (headphone) jack	❷ Audio-in (microphone) jack
❸ USB ports (2)	❹ Optical drive
	❺ Optical drive button
	❻ Serial port

## Left-side components

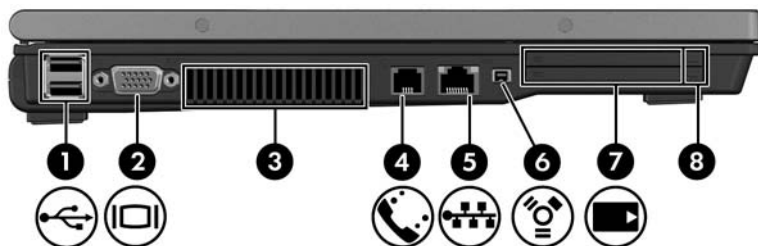

### Component

❶	USB ports (2)	❺	RJ-45 (network) jack
❷	External monitor port	❻	1394 port
❸	Exhaust vent	❼	PC Card slots (2)
❹	RJ-11 (modem) jack	❽	PC Card slot eject buttons (2)

## Bottom components

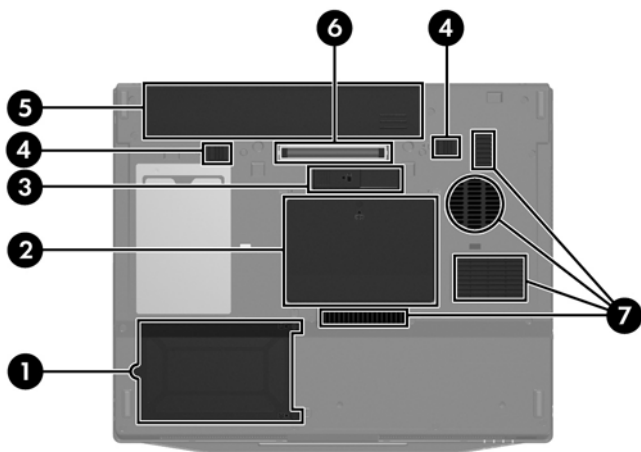

---

### Component

---

①	Hard drive bay	⑤	Primary battery bay
②	Expansion memory module and Mini PCI compartment	⑥	Docking connector
③	Travel battery connector	⑦	Exhaust vents (4)
④	Primary battery pack release latches (2)		

---

## Set up the computer

---



**CAUTION:** To prevent file corruption and to ensure that the correct drivers are installed:

- Do not set up the computer for the first time while the computer is docked in an optional docking device.
  - During the hardware and software setup procedures:
    - Do not unplug the computer from external power.
    - Do not shut down the computer or initiate standby or hibernation.
- 

When setting up the computer, you will

1. Insert the battery pack into the computer so that it can begin to charge as soon as the computer is connected to external power.
2. Connect the computer to external power.
3. Turn on the computer.
4. Set up the software.

## Step 1: Insert the battery pack

To insert a primary battery pack:

1. Turn the computer upside down.
2. Slide the battery pack ❶ into the battery bay until it is seated.

The battery pack release latches ❷ automatically lock the battery into place.

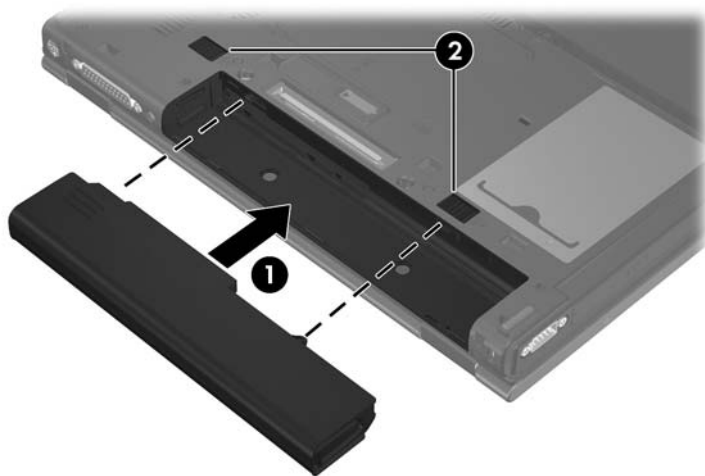



## **Step 2: Connect the computer to external power**

To connect the computer to external AC power:

1. Plug the AC adapter cable ❶ into the power connector.  
(The power connector is on the rear of the computer.)
2. Plug the power cord ❷ into the AC adapter, and then into an AC outlet ❸.

When the computer receives AC power, the battery pack begins to charge and the battery light (on the front of the computer) ❹ is turned on. When the battery pack is fully charged, the battery light is turned off.

## First-time setup

---

It is recommended that you leave the computer connected to external power until the battery pack is fully charged and the battery light is turned off. (A partially charged new battery pack can run the computer after software setup is complete, but battery charge displays will not be accurate until the new battery pack has been fully charged.)

---



Power cords and AC outlets vary in appearance by region and country.

---



## Step 3: Turn on the computer

To open the computer:

1. Slide the display release latch **1** to the right to release the display.
2. Raise the display **2**.



3. Press the power button **1**.

The power light next to the power button **2** and the power light on the front of the computer **3** are turned on, and you are prompted to begin software setup.



## Step 4: Set up the software

After the computer is turned on, it will go through a brief software setup. Follow the on-screen instructions to set up the software. Note the following:

- After you respond to the setup prompt, you must complete the entire setup process without interruption. Setup time varies.
- During software setup, it is normal for some computer models to pause occasionally for several minutes. These normal pauses are indicated by an hourglass icon.



**CAUTION:** If you are prompted to select an operating system language before the “Welcome to Windows” page is displayed, choose carefully. On some models, the languages that you do not choose are deleted from the system and cannot be restored during software setup.

---



To register your operating system and your computer, you must be connected to the Internet. For more information about connecting to the Internet, refer to [Appendix C, “Connect to the Internet from your home”](#) in this guide. If you do not send your registration during software setup, you can do so at any time after software setup is complete.

---



# 2

---

## Next steps

### **Install additional hardware and software**

To install additional hardware, such as an optional printer, follow the instructions provided by the hardware manufacturer to install any drivers required by the device.

Install new software by inserting the software disc into the optical drive and follow the on-screen instructions.

### **Protect the computer**

The information in this section is designed to protect the computer from damage caused by a virus, a security breach, a power surge, or unsafe operation.

### **Protect the computer from viruses**

When you use the computer for e-mail, network, or Internet access, you expose it to computer viruses that can disable the operating system, applications, or utilities or cause them to function abnormally.

Antivirus software can detect most viruses, destroy them, and in most cases, repair any damage they have caused. To provide ongoing protection against newly discovered viruses, antivirus software must be kept up to date.

Norton AntiVirus is preinstalled on the computer. For information about using the Norton AntiVirus software, click **Start > All Programs > Norton AntiVirus > Help and Support**.

For more information about computer viruses, type viruses in the Search field in the Help and Support Center.

## Protect your system files

System Restore is an operating system feature that allows you to reverse undesirable changes to your computer by restoring the computer to an earlier state, called a *restore point*.

You can manually create additional restore points to provide increased protection for your system files and settings. It is recommended that you manually create restore points

- Before you add or extensively modify software or hardware.
- Periodically, whenever the system is performing optimally.

For more information about setting and restoring from restore points, refer to “[Using System Restore points](#)” in, [Appendix B](#), “[System recovery](#).”

## Protect your privacy

When you use the computer for e-mail, network, or Internet access, it is possible for unauthorized persons to obtain information about you or your computer.

To optimize the privacy protection features included with the computer, it is recommended that you

- Keep your operating system and software updated. Many software applications contain security enhancements. For information about updating your operating system and software, refer to “[Update your software](#)” later in this chapter.
- Use a firewall. A firewall is software that monitors incoming traffic on the computer. Some firewalls also monitor outgoing traffic.



## Protect the computer from power surges

To protect the computer from the power surges that may be caused by an uncertain power supply or an electrical storm:

- Plug the computer power cord into an optional, high-quality surge protector. Surge protectors are available from most computer or electronics retailers.
- During an electrical storm, either run the computer on battery power or shut down the computer and unplug the power cord.
- If applicable to your location, provide surge protection on the modem cable that connects the modem to a telephone line. Telephone line surge protectors are available from computer or electronic retailers in some regions.

## Use the computer safely

---



**WARNING:** To reduce the risk of electric shock or damage to your equipment:

- Plug the power cord into an AC outlet that is easily accessible at all times.
  - Disconnect power from the computer by unplugging the power cord from the AC outlet (not by unplugging the power cord from the computer).
  - If provided with a 3-pin attachment plug on your power cord, plug the cord into a grounded (earthed) 3-pin outlet. Do not disable the power cord grounding pin; for example, by attaching a 2-pin adapter. The grounding pin is an important safety feature.
-



**WARNING:** To reduce the risk of serious injury, read the *Safety and Comfort Guide* (not available in all languages). It describes proper workstation setup; and proper posture, health, and work habits for computer users. The *Safety and Comfort Guide* also provides important electrical and mechanical safety information. This guide is available on the Web at <http://www.hp.com/ergo>, and in the Help and Support Center. To access the Help and Support Center, select **Start > Help and Support > User Guides**.

---



**WARNING:** To avoid potential discomfort or burns, do not block the air vents or use the computer on your lap for extended periods. The computer is designed to run demanding applications at full power. As a result of increased power consumption, it is normal for the computer to feel warm or hot when used continuously. The computer complies with the user-accessible surface temperature limits defined by the International Standard for Safety of Information Technology Equipment (IEC 60950).

---



**WARNING:** To reduce potential safety issues, only the AC adapter or battery pack provided with the computer, a replacement AC adapter or battery pack provided by HP, or a compatible AC adapter or battery pack purchased as an accessory from HP should be used with the computer.

---

For more safety and regulatory information, refer to *Regulatory and Safety Notices* located in the Help and Support Center. To access the Help and Support Center, select **Start > Help and Support > User Guides**.

## Connect to a computer network

The computer may have the following networking capabilities:

- Local area network (LAN)
- Wireless local area network (WLAN)
- Wireless wide-area network (WWAN)

Contact your network administrator to connect the computer to a company LAN or WLAN.

If you plan to connect the computer to a home office LAN or WLAN, you must have a router or wireless router. Refer to the documentation that came with the router for additional information, or refer to the Help and Support Center for information on networking.

For information on connecting to a WWAN, refer to the *HP Broadband Wireless Getting Started* guide that came with the computer.



For information on connecting the computer to the Internet when you are not connected to a network, refer to [Appendix C, “Connect to the Internet from your home.”](#)

---

## Update your software

Most software, including the operating system, is updated frequently by the manufacturer or provider. Important updates to the software included with the computer may have been released since the computer left the factory.

Some updates may affect the way the computer responds to optional software or external devices. Many updates provide security enhancements.

It is strongly recommended that you update the operating system and other software provided on the computer as soon as the computer is connected to the Internet.

To access update links for the operating system and other software provided on the computer:

- » Select **Start > Help and Support**.

## Locate the user guides

User guides, regulatory and safety notices, and other resources that provide information about using the computer are available through the Help and Support Center (select **Start > Help and Support > User Guides**), or on a *User Guides* disc included with some models.

For more information about the resources available through the Help and Support Center, refer to “[Help and Support Center](#)” in [Chapter 3, “Troubleshooting.”](#)”

## Turn off the computer correctly

Whenever possible, turn off the computer by using the standard Windows shutdown procedure:

4. Save your work and close all open applications.
5. Shut down the computer through the operating system by selecting **Start > Turn Off Computer > Turn Off**.

 Depending on your network connections, the **Turn Off Computer** button may be called the **Shut Down** button.

If the system is unresponsive and you are unable to shut down the computer with these procedures, use the following emergency procedures in the sequence provided:



**CAUTION:** Emergency shutdown procedures result in the loss of unsaved information.

---

- Press **ctrl+alt+delete**. Then, select **Shut Down > Turn Off**.
- Press and hold the power button for at least 5 seconds.
- Disconnect the computer from external power and remove the battery pack.

*Next steps*

---

# 3

---

## Troubleshooting

### Troubleshooting resources

If you experience computer problems with your computer, try the following suggestions in the order listed below and presented in this chapter:

1. Refer to “Quick troubleshooting,” next in this chapter.
2. Access the Help and Support Center for additional information about your computer. Select **Start > Help and Support**.



Although many checkup and repair features require an Internet connection, many other features can help you fix a problem while the computer is offline.

3. Visit the technical support Web site at <http://www.hp.com/support> for answers to common questions.
4. Contact Customer Care for any further assistance.

## Quick troubleshooting

### Is the computer unable to start up?

To turn on the computer, press the power button. When the computer is turned on, the power light is turned on.

If the computer and the power light are not turned on when you press the power button, adequate power may not be available to the computer.

- If the computer is running on battery power or is connected to an external power source other than an AC outlet, connect the computer into an AC outlet using the AC adapter. Make sure the power cord and AC adapter connections are secure.
- Verify that the AC outlet is providing adequate power by plugging another electrical device into the outlet.



If the computer can be turned on when connected to external power but cannot be turned on when running on a battery pack, recharge the battery pack.

---



## Is the computer screen blank?

If you have not turned off the computer but the screen is blank, the computer may be in standby or hibernation, may not be set to display the image on the computer screen, or the display switch or ambient light sensor (select models only) may not be functioning properly.

The suggested actions below may help you determine the reason the computer screen is blank.

- To resume from standby or restore from hibernation, briefly press the power button.

Standby and hibernation are energy-saving features that can turn off the display. Standby and hibernation can be initiated by the system while the computer is in Microsoft® Windows® but is not in use. To change these and other power settings, select **Start > Control Panel > Performance and Maintenance > Power Options**.

- To transfer the image to the computer screen, press **fn+f4**.

On most models, when an optional external display device, such as a monitor, is connected to the computer, the image can be displayed on the computer screen or the external display, or on both devices simultaneously. When you press **fn+f4** repeatedly, the image alternates among the computer display, one or more external display devices, and simultaneously displays on all devices.

- Press the display switch on the computer to confirm that it moves freely.

The display switch is normally located on the upper-left corner of the keyboard.

- If the computer has an ambient light sensor (select models only), make sure that the sensor is not obstructed.

The ambient light sensor is normally located on the lower-left corner of the display.

## Is software functioning abnormally?

If the software becomes unresponsive or responds abnormally:

- Restart the computer:
  - ❑ In Windows XP Home, select **Start > Turn Off Computer > Restart**.
  - ❑ In Windows XP Professional, select **Start > Turn Off Computer > Restart > OK**. (The Turn Off Computer button may be called the Shut Down button, depending on the network connections.)

If you cannot restart the computer using these procedures, refer to the next section, “[Is the computer unresponsive?](#)”

- Run a virus scan. For information about using the antivirus resources on your computer, refer to “[Protect the computer from viruses](#)” in the [Chapter 2, “Next steps.”](#)

## Is the computer unresponsive?

Whenever possible, turn off the computer by using the standard Windows shutdown procedure for your operating system:

- Save your work and close all open applications.
- Shut down the computer through the operating system by selecting **Start > Turn Off Computer > Turn Off**. (In Windows XP Professional, the Turn Off Computer button may be called the Shut Down button, depending on the network connections)

If the system is unresponsive and you are unable to shut down the computer with these procedures, use the following emergency procedures in the sequence provided:



**CAUTION:** Emergency shutdown procedures result in the loss of unsaved information.

---

1. Press **ctrl+alt+delete**. Then, select **Shut Down > Turn Off**.
2. Press and hold the power button for at least 5 seconds.
3. Disconnect the computer from external power and remove the battery pack.

## Is the computer overheating?

It is normal for the computer to feel warm to the touch while it is in use. But if the computer feels *unusually* warm, it may be overheating because a vent is blocked.

If you suspect that overheating could be causing the problem, allow the computer to cool to room temperature. Then be sure to keep all vents free from obstructions while you are using the computer.



**CAUTION:** To prevent overheating, do not obstruct vents. Use the computer only on a hard, flat surface. Do not allow another hard surface, such as an adjoining optional printer, or a soft surface, such as a pillows or thick rugs or clothing, to block airflow.

---



The fan in the computer starts up automatically to cool internal components and prevent overheating. It is normal for the internal fan to cycle on and off during routine operation.

---

## Is an external device not working?

If an external device does not function as expected:

- Turn on the device as instructed in the device documentation. Some devices, such as monitors and printers, must be turned on before the computer is turned on.
- Verify that
  - ❑ All device connections are secure.
  - ❑ The device is receiving electrical power.
  - ❑ The device, especially if it is an older one, is compatible with your operating system. For compatibility information, select **Start > Help and Support**, or visit the Web site of the device manufacturer or provider.
  - ❑ The correct drivers are installed and updated. Drivers may be available on a CD included with the device or on the Web site of the device manufacturer. For more information about updating drivers, select **Start > Help and Support**.

## Help and Support Center

To access the Help and Support Center, select **Start > Help and Support**. In addition to providing information about your operating system, the Help and Support Center provides

- Information about your computer, such as model and serial number, installed software, hardware components, and specifications.
- Answers to question about using your computer.
- Product information to help you learn to use computer and operating system features.
- Updates for your operating system, device drivers, and the software provided on your computer.
- Checkups for computer functionality.
- Automated and interactive troubleshooting, repair solutions, and system recovery procedures.
- Links to Customer Care specialists.
- Links to community forums of IT experts.

## Customer Care

If you are unable to find the help you need by using the Help and Support Center at **Start > Help and Support**, you may need to contact Customer Care.

### Preparing to contact Customer Care

For the fastest possible resolution of your problem, have the computer and the following information available when you call or e-mail:

- Product name located on the display or keyboard.
- Serial number (s/n) listed on the service tag.
  - The service tag label is on the bottom of the computer.
  - To display the service tag information on the computer screen, select **Start > Help and Support > My Computer**.
- Date the computer was purchased.
- Conditions under which the problem occurred.
- Error messages that have been displayed.

- The manufacturer and model of a printer or other accessories connected to the computer.
- Operating system version number and registration number.

To display the operating system version number and registration number, select **Start > Help and Support > My Computer**. (On some models, the registration number may be identified in the Operating System table as the *Product Id*).

## Contacting Customer Care by e-mail or telephone

If the computer is connected to the Internet, select **Start > Help and Support** to get help by e-mail or you can access Customer Care telephone numbers.



# A

---

## Specifications

The following sections provide information on the operating environment specifications and power specifications of the computer.

### Operating Environment

The operating environment information in the following table may be helpful if you plan to use or transport the computer in extreme environments.

Factor	Metric	U.S.
<b>Temperature</b>		
Operating (not writing to optical disc)	0°C to 35°C	32°F to 95°F
Operating (writing to optical disc)	5°C to 35°C	41°F to 95°F
Nonoperating	-20°C to 60°C	-4°F to 140°F
<b>Relative humidity</b> (noncondensing)		
Operating	10% to 90%	10% to 90%
Nonoperating	5% to 95%	5% to 95%
<b>Maximum altitude</b> (unpressurized)		
Operating (14.7 to 10.1 psia*)	-15 m to 3,048 m	-50 ft to 10,000 ft
Nonoperating (14.7 to 4.4 psia*)	-15 m to 12,192 m	-50 ft to 40,000 ft

\*Pounds per square inch absolute (psia) is another unit of measurement for altitude.

## Rated Input Power

The power information in this section may be helpful if you plan to travel internationally with the computer.

The computer operates on DC power, which can be supplied by an AC or a DC power source. Although the computer can be powered from a stand-alone DC power source, it is strongly recommended that the computer be powered only with an AC adapter or a DC power cord supplied by or approved for an HP computer.

The computer is capable of accepting DC power within the following specifications.

<b>Input Power</b>	<b>Rating</b>
Operating voltage	18.5 V dc @ 3.5 A - 65 W
Operating current	3.5 A

# B

---

## System recovery

### Safeguarding your data

Software or devices added to the computer can cause your system to become unstable. To safeguard your documents, store personal files in the My Documents folder and periodically create a backup copy of the My Documents folder.

### Using Altiris Local Recovery (select models only)

Altiris Local Recovery is a preloaded application that protects the files on your computer by storing copies of files, called *snapshots*. If files on your computer are accidentally deleted or corrupted, you can easily restore the files yourself. You can also restore your complete file system to a previous state.

Altiris Local Recovery provides protection of files by backing up files to a hidden Altiris recovery partition. When you install the software, the Recovery Agent Partition Wizard guides you through the process of creating the recovery partition. After the partition is created, the computer restarts and creates the first snapshot. After the snapshot is created, the computer restarts, making the snapshot available for recovery through Windows.

By default, Local Recovery automatically takes snapshots of your files on a regular basis. You can change the snapshot schedule. For more information, refer to the Altiris Local Recovery Help.

To access your snapshots in the Altiris Recovery Agent folder:

1. Right-click the Altiris Recovery Agent icon on your desktop.
2. Click **Open**.

To restore one of the listed snapshots:

- » Drag the snapshot file to the appropriate location on your hard drive.

For more information on configuring and using Altiris Local Recovery, visit the HP Web site at <http://www.hp.com/go/easydeploy>, or open the software and click **Help** on the menu bar.

## Using System Restore points

System Restore is an operating system feature that allows you to reverse undesirable changes to your computer by restoring the computer to an earlier state, called a *restore point*. A restore point is a “snapshot” of your software, drivers, and operating system files at a particular time. The computer automatically creates restore points at regular intervals and may create additional restore points when you change your personal settings or add software or hardware.

You can manually create additional restore points to provide increased protection for your system files and settings. It is recommended that you manually create restore points

- Before you add or extensively modify software or hardware.
- Periodically, whenever the system is performing optimally.

Restoring to any restore point does not affect your data files. For example, restoring your system software to an earlier state will not affect documents or e-mails that you saved after that time.



If you do not like the results of your restoration, you can reverse the restoration.

---

## Creating a System Restore Point

To create a system restore point:

1. Click **System Restore** in the Help and Support Center.  
The System Restore window opens.
2. Click **Create a restore point**, and then click **Next**.
3. Follow the on-screen instructions.

## Restoring to a restore point

To restore the computer to a previous date and time when it was functioning optimally:

1. Click **System Restore** in the Help and Support Center.  
The System Restore window opens.
2. Click **Restore my computer to an earlier time**, and then click **Next**.
3. Follow the on-screen instructions.

## Reinstalling applications

Applications preinstalled or preloaded on your computer can be reinstalled by using the *Recovery* disc or a third-party software disc.



In most cases, the applications preloaded on your computer, such as those available in the Software Setup utility, can be reinstalled from your hard drive. To access the Software Setup utility, select **Start > All Programs > Software Setup**.

---

The application reinstallation process replaces corrupted system files within the application and reinstalls deleted system files within the application.

- In most cases: If the application you are reinstalling is still installed on your computer, the reinstallation process does not affect your settings within the application.
- In all cases: If an application has been deleted from your computer, the reinstallation process reinstalls the application or utility to the factory image but cannot restore your personal settings.

## Reinstalling applications from the hard drive

To reinstall a preloaded application or utility from your hard drive:

1. Select **Start > All Programs > Software Setup**, and then follow the instructions on the screen.
2. When you are prompted to select the software you want to reinstall, select or clear the appropriate check boxes.

## Reinstalling applications from discs

To reinstall applications from discs:

1. Insert the disc into the optical drive.
2. When the installation wizard opens, follow the installation instructions on the screen.
3. Restart the computer if prompted.

---

## Repairing the operating system

To attempt an operating system repair without deleting your personal data, use the *Operating System* disc that was shipped with the computer:



---

If your computer does not have an optical drive, you may need to connect to an optional external MultiBay.

---

1. Connect the computer to external power through the AC adapter and turn on the computer.
2. Immediately insert the *Operating System* disc into the computer.
3. Press and hold the power button for at least 5 seconds to turn off the computer.
4. Press the power button again to turn on the computer.
5. When prompted, press any key to start from the disc.

After a few minutes, you may need to select your language, and then the Setup Wizard opens.



On the “Welcome to Setup” page, do not press **R** (step 8 in this procedure) until you have completed steps 6 and 7.

6. Press **enter** to continue.

A licensing agreement page is displayed.

7. Press **f8** to accept the agreement and continue.

The “Setup” page is displayed.

8. Press **R** to repair the selected Windows installation.

The repair process begins. This process takes 1 to 2 hours to complete.

The computer restarts in Windows after the process is complete.

## Reinstalling the operating system

---



**CAUTION:** To protect your personal information and the software installed on the computer, back up your information before reinstalling the operating system. See the Windows online Help utility to learn more about backing up your files. Type “backup” in the Search box in the Help and Support Center.

---



During the reinstallation, you may be prompted for your Product Key. Your Product Key is provided on the Microsoft Certificate of Authenticity label on the bottom of the computer.

---

If other recovery efforts do not successfully repair the operating system, you can reinstall it.

To reinstall the operating system:

---



If your computer does not have an optical drive, you may need to connect to an optional external MultiBay.

---

1. Connect the computer to external power through the AC adapter and turn on the computer.
2. Immediately insert the *Operating System* disc into the computer.
3. Press and hold the power button for at least 5 seconds to turn off the computer.
4. Press the power button again to turn on the computer.
5. When prompted, press any key to start from the disc.

After a few minutes, you may need to select your language, and then the Setup Wizard opens.

6. Press **enter** to continue.

A licensing agreement page is displayed.

7. Press **f8** to accept the agreement and continue.

The “Setup” page is displayed.



8. Press **esc** to continue installing a new copy of the operating system instead of repairing it.
9. Press **enter** to set up the operating system.
10. Press **C** to continue setup using this partition.
11. Select **Format the partition using the NTFS file system (Quick)**, and then press **enter**.

 Formatting this drive deletes all current files.

12. Press **F** to format the drive.

The reinstallation process begins. This process takes 1 to 2 hours to complete.

The computer restarts in Windows when the process is complete.

## Reinstalling device drivers and other software

After the operating system installation process is complete, you must reinstall drivers.

To reinstall drivers, use the *Recovery* disc included with the computer:

1. While running Windows, insert the *Recovery* disc into the optical drive.
2. Follow the on-screen instructions for installing the drivers.

After the drivers are reinstalled, you must reinstall any software you added to the computer. Follow the installation instructions provided with the software.

*System recovery*

---

---

## Connect to the Internet from your home

Your computer includes hardware and software that allows you to connect to the Internet. Before you can access the Internet, you must:

- Choose an Internet Service Provider (ISP).
- Choose the type of Internet access you want, and connect the hardware.



Internet hardware and software features vary depending on your computer model and your location.

---

### Choose an ISP

You must set up Internet service before you can connect to the Internet. The computer includes the New Connection Wizard to help you set up a new Internet account or configure the computer to use an existing account.

## Using the Internet Connection Wizard

You can use the New Connection Wizard to connect to the Internet

- If you already have an account with an ISP.
- If you have a disc from an ISP.
- If you do not have an Internet account and would like to select an ISP from the list provided within the wizard.
- If you have selected an unlisted ISP and the ISP has provided you with such information as a specific IP address, and POP3 and SMTP settings.

To access the New Connection Wizard and instructions for using the wizard:

- » Select **Start > Help and Support**.



If you are prompted within the wizard to choose between enabling or disabling Windows Firewall, choose to enable the firewall. For more information about firewalls, refer to “[Protect your privacy](#)” in [Chapter 2](#), “Next steps.”

---

## Choose the type of Internet access

There are 3 basic types of Internet access:

- **Dial-up:** You can access the Internet by dialing into a service provider using a modem cable connected to an RJ-11 (modem) jack.
- **Broadband:** High-speed Internet access is available through:
  - ❑ Cable modem
  - ❑ Digital Subscriber Line (DSL)
  - ❑ Satellite
  - ❑ Other services

For broadband access, additional hardware and/or software must be provided by your ISP. Refer to “[Choose an ISP](#),” or contact your ISP for details.

- **Wireless:** For high-speed mobile Internet access, you can use a wireless connection. A wireless network set up at home requires a wireless router, purchased separately. To learn about setting up wireless access, select <http://www.hp.com/go/wireless>.

*Connect to the Internet from your home*

---

---

# Index

## A

- AC adapter
  - connecting 1–11
- altitude specifications A–1
- antivirus software 3–4
- Application and Driver Recovery* disc B–7
- applications, reinstalling or repairing B–5, B–6, B–7

## B

- battery light
  - displaying charge status 1–11
- battery pack
  - charging 1–11

## C

- cables and cords
  - power 3–2
- computer viruses 3–4
- cord, power
  - connecting 1–11

## D

- devices, external
  - troubleshooting 3–7
- display, switching image 3–3

- drivers, reinstalling or repairing B–7

## E

- environmental specifications A–1
- external devices
  - troubleshooting 3–7

## H

- hibernation 3–3
- humidity specifications A–1

## I

- IEC 60950 compliance 2–4
- image, switching among display devices 3–3

## L

- labels
  - Service Tag 3–9
- lights
  - battery 1–11
  - power/standby 1–14
  - power/standby button 1–14

## M

- monitor, external 3–3, 3–7

## **O**

- operating environment
  - specifications A-1
- operating system
  - displaying version number 3-10
  - Windows reinstalling or repairing B-7
- Operating System* disc B-5, B-6
- overheating, computer 3-6
- overheating, safety considerations 2-4

## **P**

- power
  - running the computer on battery 1-12
  - turning on computer 3-2
- power connector 1-11
- power cord
  - connecting 1-11
- power/standby light 1-14
- power/standby lights
  - on, off 3-2
- printer 3-7
- Product Id 3-10
- product number, computer 3-9

## **R**

- rated input power
  - specifications A-2
- registration number, operating system 3-10
- regulatory information notices 2-4

- reinstalling or repairing software B-5, B-6, B-7
- reset (emergency shutdown) 3-5

## **S**

- Safety and Comfort Guide* 2-4
- serial number, computer 3-9
- Service Tag 3-9
- snapshot B-2
- software
  - antivirus 2-1
  - reinstalling or repairing B-5, B-6, B-7
- specifications
  - operating environment A-1
  - rated input power A-2
- standby 3-3
- system lock-up 3-5

## **T**

- temperature
  - troubleshooting 3-6
- temperature specifications A-1
- temperature, safety considerations 2-4
- traveling with computer
  - environmental specifications A-2
- troubleshooting procedures
  - display problems 3-3
  - external device problems 3-7
  - hibernation or standby problems 3-3
  - overheating problems 3-6



software problems 3–4  
virus problems 3–4  
turning on computer 3–2

**V**

vents 3–6  
viruses, antivirus software 2–1  
viruses, computer 3–4

**W**

*Wireless Regulatory Notices*  
2–4

