



CDMA and GSM / UMTS Mini Card

Hardware Integration Guide

Proprietary and Confidential

Includes:

MC5725	MC8301V
MC5725V	MC8775
MC5727	MC8775V
MC5727V	MC8780
MC5728V	MC8781
	MC8790
	MC8790V
	MC8791V
	MC8792V
	MC8795V
	MC8700

2130114
Rev 1.12.5

Important Notice

Due to the nature of wireless communications, transmission and reception of data can never be guaranteed. Data may be delayed, corrupted (i.e., have errors) or be totally lost. Although significant delays or losses of data are rare when wireless devices such as the Sierra Wireless modem are used in a normal manner with a well-constructed network, the Sierra Wireless modem should not be used in situations where failure to transmit or receive data could result in damage of any kind to the user or any other party, including but not limited to personal injury, death, or loss of property. Sierra Wireless accepts no responsibility for damages of any kind resulting from delays or errors in data transmitted or received using the Sierra Wireless modem, or for failure of the Sierra Wireless modem to transmit or receive such data.

Safety and Hazards

Do not operate the Sierra Wireless modem in areas where blasting is in progress, where explosive atmospheres may be present, near medical equipment, near life support equipment, or any equipment which may be susceptible to any form of radio interference. In such areas, the Sierra Wireless modem **MUST BE POWERED OFF**. The Sierra Wireless modem can transmit signals that could interfere with this equipment.

Do not operate the Sierra Wireless modem in any aircraft, whether the aircraft is on the ground or in flight. In aircraft, the Sierra Wireless modem **MUST BE POWERED OFF**. When operating, the Sierra Wireless modem can transmit signals that could interfere with various onboard systems.

Note: Some airlines may permit the use of cellular phones while the aircraft is on the ground and the door is open. Sierra Wireless modems may be used at this time.

The driver or operator of any vehicle should not operate the Sierra Wireless modem while in control of a vehicle. Doing so will detract from the driver or operator's control and operation of that vehicle. In some states and provinces, operating such communications devices while in control of a vehicle is an offence.

Limitation of Liability

The information in this manual is subject to change without notice and does not represent a commitment on the part of Sierra Wireless. SIERRA WIRELESS AND ITS AFFILIATES SPECIFICALLY DISCLAIM LIABILITY FOR ANY AND ALL DIRECT, INDIRECT, SPECIAL, GENERAL, INCIDENTAL, CONSEQUENTIAL, PUNITIVE OR EXEMPLARY DAMAGES INCLUDING, BUT NOT LIMITED TO, LOSS OF PROFITS OR

Patents

REVENUE OR ANTICIPATED PROFITS OR REVENUE ARISING OUT OF THE USE OR INABILITY TO USE ANY SIERRA WIRELESS PRODUCT, EVEN IF SIERRA WIRELESS AND/OR ITS AFFILIATES HAS BEEN ADVISED OF THE POSSIBILITY OF SUCH DAMAGES OR THEY ARE FORESEEABLE OR FOR CLAIMS BY ANY THIRD PARTY.

Notwithstanding the foregoing, in no event shall Sierra Wireless and/or its affiliates aggregate liability arising under or in connection with the Sierra Wireless product, regardless of the number of events, occurrences, or claims giving rise to liability, be in excess of the price paid by the purchaser for the Sierra Wireless product.

Portions of this product may be covered by some or all of the following US patents:

5,515,013	5,629,960	5,845,216	5,847,553	5,878,234
5,890,057	5,929,815	6,169,884	6,191,741	6,199,168
6,339,405	6,359,591	6,400,336	6,516,204	6,561,851
6,643,501	6,653,979	6,697,030	6,785,830	6,845,249
6,847,830	6,876,697	6,879,585	6,886,049	6,968,171
6,985,757	7,023,878	7,053,843	7,106,569	7,145,267
7,200,512	7,295,171	7,287,162	D442,170	D459,303
D599,256	D560,911			

and other patents pending.

This product includes technology licensed from QUALCOMM® 3G.

Manufactured or sold by Sierra Wireless or its licensees under one or more patents licensed from InterDigital Group.

Copyright

©2010 Sierra Wireless. All rights reserved.

Trademarks

AirCard® and “Heart of the Wireless Machine®” are registered trademarks of Sierra Wireless. Watcher® is a trademark of Sierra Wireless, registered in the European Community. Sierra Wireless, the Sierra Wireless logo, the red wave design, and the red-tipped antenna are trademarks of Sierra Wireless.

Windows® is a registered trademark of Microsoft Corporation.

QUALCOMM® is a registered trademark of QUALCOMM Incorporated. Used under license.

Linux® is a registered trademark of Linus Torvalds.

Other trademarks are the property of the respective owners.

**Contact
Information**

Sales Desk:	Phone:	1-604-232-1488
	Hours:	8:00 AM to 5:00 PM Pacific Time
	E-mail:	sales@sierrawireless.com
Post:	Sierra Wireless 13811 Wireless Way Richmond, BC Canada V6V 3A4	
Fax:	1-604-231-1109	
Web:	www.sierrawireless.com	

Consult our website for up-to-date product descriptions, documentation, application notes, firmware upgrades, troubleshooting tips, and press releases:

www.sierrawireless.com

»» | Table of Contents

Introduction	9
The Universal Development Kit	9
Required connectors	10
Guide organization	10
Related documents	11
Power Interface	15
Overview of operation	15
Power signals	15
Electrostatic discharge (ESD)	15
Module power states	16
Disconnected state	16
Off state	17
Normal state	17
Low power mode	17
Usage models	17
RF Integration	19
RF connection	20
Ground connection	21
Shielding	22
Antenna and cabling	22
Interference and sensitivity	23
Power supply noise	23
Interference from other wireless devices	23
Device-generated RF	24
Audio Interface	25

System block diagrams	26
Modes of operation	29
Sidetone support	29
Echo cancellation support	30
Audio signal interface	31
Audio function partitioning	32
Host / Module Interfaces	35
LED output	35
Regulatory Information	37
Important notice	37
Safety and hazards	37
Important compliance information for North American users	38
EU regulatory conformity	39
Brazil ANATEL homologation	40
Acronyms and Definitions	41
Index	45

1: Introduction

Note: Throughout this document, MC57xx and MC8xxx refer to the entire suites of CDMA and GSM Mini Cards respectively.

Sierra Wireless' Mini Card modules form the radio component for the products in which they are embedded. Mini Cards are available for use on CDMA and GSM networks, including:

- **MC5725 / MC5725V / MC5727 / MC5727V / MC5728V**—Operate on CDMA networks using the CDMA IS-95A, 1X, and 1xEV-DO (IS-856) network standards, and support GPS.
- **MC8775 / MC8775V**—Operate on GSM networks using the GSM / GPRS / EDGE / UMTS / HSDPA network standards, and support Standalone GPS functionality.
- **MC8301V / MC8780 / MC8781 / MC8790 / MC8790V / MC8791V / MC8792V / MC8795V**—Operate on GSM networks using the GSM / GPRS / EDGE / UMTS / HSDPA / HSUPA network standards, and support Standalone GPS, gpsOneXTRA™, A-GPS, selected enhanced Navigation 2.0 features, and five NMEA sentences.
- **MC8700**—Operates on GSM networks using the GSM / GPRS / EDGE / UMTS / HSDPA / HSUPA / HSPA+ network standards.

Purpose of this guide

This guide addresses issues that affect the integration of Sierra Wireless modules into host products, and includes design recommendations for the host products.

Note: An understanding of network technology and experience in integrating hardware components into electronic equipment is assumed.

The Universal Development Kit

Sierra Wireless manufactures a Universal Development Kit (UDK) that facilitates all phases of the integration process.

This kit is a hardware development platform that is designed to support multiple members of the wireless embedded module product family. It contains the hardware components that are typically necessary for evaluating and developing with the module, including:

- Development board
- Cables
- Antennas
- Other accessories

Note: Contact vendors before choosing your connectors — the numbers included here are for reference only. Choose connectors that are appropriate to your design.

For instructions on setting up the UDK, see *PCI Express Mini Card Dev Kit Quick Start Guide (Document 2130705)*.

Required connectors

When integrating these modules into your host device, you need the following connector types:

- RF cables that mate with Hirose U.FL connectors (model U.FL #CL331-0471-0-10). Modules include one or two connector jacks depending on individual module support for diversity or GPS functionality.
- Industry-standard mating connector for 52-pin EDGE—some manufacturers include Tyco, Foxconn, and Molex. For example, the connector used on the Mini Card Dev Kit board is a Molex 67910-0001.
- Industry-standard USIM connector (MC8xxx only)—the actual connector you use depends on how your device exposes the USIM socket. For example, the USIM connector used on the Mini Card Dev Kit board is an ITT CCM03-3518.

Guide organization

This guide includes the following sections:

1. **Introduction** (this section)
2. **Power Interface** (p.15)
Describes power control signals used by the module and discusses design issues related to power supply integration.
3. **RF Integration** (p.19)
Describes antenna connection methods and grounding issues, RF interference and desense issues.
4. **Audio Interface** (p.25)
Describes supported audio modes and related details.
5. **Host / Module Interfaces** (p.35)
Describes the USB interface for host / module communication, and the USIM interface for host / module integration.
6. **Regulatory Information** (p.37)
Describes regulatory approvals and regulatory information requirements.
7. **Acronyms and Definitions** (p.41)
Lists acronyms and definitions used throughout this guide.
8. **Index** (p.121)

Note: The term "host" always refers to the host device.

Related documents

This guide deals specifically with hardware integration issues that are unique to the MC57xx and MC8xxx modules.

[Table 1-1](#) lists other documents referenced in this guide.

Table 1-1: Related documentation

Document title	Description
AT Command Set for User Equipment (UE) (Release 6)	Standard AT commands for GSM / UMTS devices. Download this document (3GPP TS 27.007) from www.3gpp.org .
CDMA 1X Standard	Technical requirements for CDMA systems, including details on sleep cycle index (SCI) values. Order this document, CDMA 2000 Series Release A (2000) (document # TIA/EIA/IS-2000 Series, Release A) from www.tiaonline.org .
CDMA CnS Reference (Document 2130754)	CnS (Control and Status) messages that are supported by the MC5725 / MC5725V / MC5727 / MC5727V / MC5728V.
CDMA AT Command Reference (Document 2130620)	Proprietary, basic AT commands for the MC5725 / MC5725V / MC5727 / MC5727V / MC5728V. For MC8xxx-specific commands, see <i>UMTS Modems Supported AT Command Reference (Document 2130617)</i> .
CDMA Extended AT Command Reference (Document 2130621)	Proprietary AT commands for the MC5725 / MC5725V / MC5727 / MC5727V / MC5728V. For MC8xxx-specific commands, see <i>MC87xx Modem Extended AT Command Reference (Document 2130616)</i> .
FCC Regulations - Part 15 - Radio Frequency Devices	This section of the FCC Code of Federal Regulations, Title 47 deals with radio frequency devices, including shielding requirements for embedded modules. Download this regulation from http://wireless.fcc.gov .
IEC-61000-4-2 level 3	Techniques for testing and measuring electrostatic discharge (ESD) immunity. Order this document from www.iec.ch .
MC5725 Mini Card Product Specification (Document 2130663)	Features, mechanical and electrical specifications, and standards compliance of the MC5725.
MC5725V Mini Card Product Specification (Document 2130671)	Features, mechanical and electrical specifications, and standards compliance of the MC5725V.

Table 1-1: Related documentation (Continued)

Document title	Description
MC5727 Mini Card Product Specification (Document 2130958)	Features, mechanical and electrical specifications, and standards compliance of the MC5727.
MC5727V Mini Card Product Specification (Document 2131023)	Features, mechanical and electrical specifications, and standards compliance of the MC5727V.
MC5728V Mini Card Product Specification (Document 2111350)	Features, mechanical and electrical specifications, and standards compliance of the MC5728V.
MC8301V PCI Express Mini Card Product Specification (Document 2131326)	Features, mechanical and electrical specifications, and standards compliance of the MC8301V.
MC8775 PCI Express Mini Card Product Specification (Document 2130697)	Features, mechanical and electrical specifications, and standards compliance of the MC8775.
MC8775V with Audio PCI Express Mini Card Product Specification (Document 2130700)	Features, mechanical and electrical specifications, and standards compliance of the MC8775V.
MC8780 / MC8781 PCI Express Mini Card Product Specification (Document 2130782)	Features, mechanical and electrical specifications, and standards compliance of the MC8780 / MC8781.
MC8790 PCI Express Mini Card Product Specification (Document 2111279)	Features, mechanical and electrical specifications, and standards compliance of the MC8790.
MC8790V PCI Express Mini Card Product Specification (Document 2111280)	Features, mechanical and electrical specifications, and standards compliance of the MC8790V.
MC8791V PCI Express Mini Card Product Specification (Document 2131032)	Features, mechanical and electrical specifications, and standards compliance of the MC8791V.
MC8792V PCI Express Mini Card Product Specification (Document 2131033)	Features, mechanical and electrical specifications, and standards compliance of the MC8792V.
MC8795V PCI Express Mini Card Product Specification (Document 2131276)	Features, mechanical and electrical specifications, and standards compliance of the MC8795V.
MC8700 PCI Express Mini Card Product Specification (Document 2131202)	Features, mechanical and electrical specifications, and standards compliance of the MC8700.

Table 1-1: Related documentation (Continued)

Document title	Description
MC87XX Modem CnS Reference (Document 2130602)	CnS (Control and Status) messages supported by the MC8xxx series of modems.
MC87xx Modem CnS Reference (Voice) (Document 2130817)	Voice-related CnS (Control and Status) messages supported by the MC8301V, MC8775V, MC8790V, MC8791V, and MC8792V, and MC8795V.
UMTS Modems Supported AT Command Reference (Document 2130617)	Proprietary, basic AT commands for the MC8xxx. For MC57xx-specific commands, see the <i>CDMA AT Command Reference (Document 2130620)</i> .
MC87xx Modem Extended AT Command Reference (Document 2130616)	Proprietary AT commands for the MC8xxx. For MC57xx-specific commands, see the <i>CDMA Extended AT Command Reference (Document 2130621)</i> .
Mobile Station (MS) Conformance Specification; Part 4: Subscriber Interface Module	SIM testing methods. Download this document (3GPP TS 11.10-4) from www.3gpp.org .
PCI Express Mini Card Dev Kit Quick Start Guide (Document 2130705)	Setup and configuration of modules.
PCI Express Mini Card Electromechanical Specification Revision 1.1	Download this document from www.pcisig.com .
Universal Serial Bus Specification, Rev 2.0	Download this specification from www.usb.org .

2: Power Interface

Overview of operation

Note: This chapter contains information for CDMA (MC57xx) and GSM (MC8xxx) modules.

*Information that is **unique** to specific module types is clearly identified.*

The module is designed to use a 3.3V (nominal) power supply, provided by the host. It is the host's responsibility to provide safe and continuous power to the module at all times; the module does NOT have an independent power supply, or protection circuits to guard against electrical issues.

The module's power state is controlled by the host's assertion / de-assertion of the W_Disable# signal. The module also monitors its supply voltage and requests shutdown if the supply is insufficient.

Power signals

The module must be connected to a 3.3V power supply (as described in *PCI Express Mini Card Electromechanical Specification Revision 1.1*).

The MC8xxx has more power pins than the MC57xx due to higher peak current requirements for GSM devices.

For detailed pinout and voltage / current requirements of these modules, see the Product Specification Document for your Mini Card.

Electrostatic discharge (ESD)

You are responsible for ensuring that the host has adequate ESD protection on digital circuits and antenna ports:

- (Operational) RF port (antenna launch and RF connector):
IEC-61000-4-2 – Level (Electrostatic Discharge Immunity Test)
- (Non-operational) Host connector interface:
*JESD22-A114-B +/- 1kV Human Body Model and
JESD22-C101 +/- 125 V Charged Device Model*
- MC5728V only: (Non-operational) Host connector interface:
*JESD22-A114-B +/- 200V Human Body Model and
JESD22-C101 +/- 250 V Charged Device Model*

MC5728V has placeholders for additional ESD devices, for cases where the device must, per customer requirements, meet the higher Human Body Model (+/-1kV) ESD rating.

Specific recommendations are provided where needed in this guide, however, the level of protection required depends on your application.

Note: ESD protection is highly recommended for the USIM connector at the point where the contacts are exposed, and for any other signals from the host interface that would be subjected to ESD by the user of the product.

Note: The module unit defaults to the Normal state when VCC3.3 is first applied in the absence of W_Disable# control.

Note: The difference between the Disconnected and Off states is that, in the Off state, the module is still connected to the power source and draws minimal current.

Module power states

The module has four power states:

- **Disconnected**
No power to the module.
- **Off**
Power to the module, but the module is powered off.
- **Normal**
The module is active. Several modes are possible (Receive, Transmit, Sleep, Shutdown).
- **Low power (“airplane mode”)**
The module is active, but RF is disabled.

State machines are implemented in the module to monitor the power supply and operating temperature.

Disconnected state

This state occurs when there is no power to the module — the host power source is disconnected from the module and all voltages associated with the module are at 0 V.

Whether the host device is also powered off depends on the power rail design. If the connection between the power rail and the module is controlled by the host, the host can stay powered on and cut the power to put the modem into the disconnected state. If the power rail is shared between the host device and the module, the host is powered off when the module is powered off.

Off state

In this state, the host is powered up and the module is powered down (but still connected to the power source).

The host keeps the module powered off by driving the W_Disable# signal low. In this state, the module draws minimal current.

Normal state

This is the active state of the module. In this state:

- The module is fully powered.
- The module is capable of placing / receiving calls or establishing data connections on the wireless network.
- The USB interface is fully active.

Low power mode

In this state, RF (both Rx and Tx) is disabled in the module, but the USB interface is still active. This low power mode ("airplane mode") is controlled by software commands through the host interface.

For instructions on using the commands, refer to *AT Command Set for User Equipment (UE) (Release 6) (+CFUN=0 command)*, *CDMA CnS Reference (Document 2130754)* (CNS_RADIO_POWER [0x1075] command), or *MC87XX Modem CnS Reference (Document 2130602)* (Disable Modem command).

Usage models

Usage models can be used to calculate expected current consumption. A sample usage model is provided in [Table 2-1](#).

Note: This is the default state when VCC3.3 is first applied in the absence of W_Disable# control.

Table 2-1: Power consumption of a sample application

	Used by a field worker (data only)	Used for remote data logging
Upload (module Tx)	1000 kB/day	40 kB/h
Download (module Rx)	500 kB/day	100 kB/day
Coverage / data rate	1X / 80 kbps	IS-95 / 14.4 kbps

Table 2-1: Power consumption of a sample application (Continued)

	Used by a field worker (data only)	Used for remote data logging
Hours of operation	8/day (off 16 hrs/day)	24/day
Total power consumed over 24 hours	60 mAh	200 mAh

This example model applies to a battery-operated device. In practice, because the module is isolated from the battery (the host device manages the power source), the mAh ratings depend on the device's supply efficiency.

The module automatically enters slotted sleep mode when there is no transmission or reception occurring (SCI = 2).

Transmit power is assumed to be +3 dBm.

3: RF Integration

The MC8xxx operates on the frequencies detailed in Table 3-1.

Table 3-1: MC8xxx— RF parameters

Product	Band	Frequencies (MHz)
MC8301V MC8775 MC8775V MC8780 MC8781 MC8790 MC8790V MC8791V MC8792V MC8795V MC8700	GSM 850 (2%) CS	Tx: 824–849 Rx: 869-894
MC8301V MC8775 MC8775V MC8780 MC8781 MC8790 MC8790V MC8791V MC8792V MC8795V MC8700	EGSM 900 (2%) CS	Tx: 880-915 Rx: 925-960
MC8301V MC8775 MC8775V MC8780 MC8781 MC8790 MC8790V MC8791V MC8792V MC8795V MC8700	DCS 1800 (2%) CS	Tx: 1710-1785 Rx: 1805-1880
MC8301V MC8775 MC8775V MC8780 MC8781 MC8790 MC8790V MC8791V MC8792V MC8795V MC8700	PCS 1900 (2%) CS	Tx: 1850-1910 Rx: 1930-1990
MC8301V MC8775 MC8775V MC8780 MC8781 MC8790 MC8790V MC8791V MC8792V MC8795V MC8700	Band I UMTS 2100 (0.1%) 12.2 kbps	Tx: 1920–1980 Rx: 2110–2170
MC8301V MC8775 MC8775V MC8780 MC8781 MC8790 MC8790V MC8792V MC8795V MC8700	Band II UMTS 1900 (0.1%) 12.2 kbps	Tx: 1850–1910 Rx: 1930–1990
MC8301V MC8775 MC8775V MC8780 MC8781 MC8790 MC8790V MC8792V MC8795V MC8700	Band V UMTS 850 (0.1%) 12.2 kbps (Band VI is included as a subset of Band V)	Tx: 824–849 Rx: 869–894

Table 3-1: MC8xxx— RF parameters (Continued)

Product	Band	Frequencies (MHz)
MC8792V MC8795V MC8700	Band VIII UMTS 900 (0.1%) 12.2 kbps	Tx: 880–915 Rx: 925–960
MC8301V MC8775V MC8780 MC8781 MC8790 MC8790V MC8791V MC8792V MC8795V	GPS	1575.42

*Note: To **disconnect** the antenna, make sure you use the Hirose U.FL connector removal tool (P/N UFL-LP-N-2(01)) to prevent damage to the module or coaxial cable assembly.*

RF connection

When attaching an antenna to the module:

- Use a Hirose U.FL connector (model U.FL #CL331-0471-0-10) to attach an antenna to a connection point on the module, as shown in [Figure 3-1](#) (the main RF connector on the top side; the diversity RF or GPS connector on the bottom side).
- Match coaxial connections between the module and the antenna to 50 Ω.
- Minimize RF cable losses to the antenna; the recommended maximum cable loss for antenna cabling is 0.5 dB.

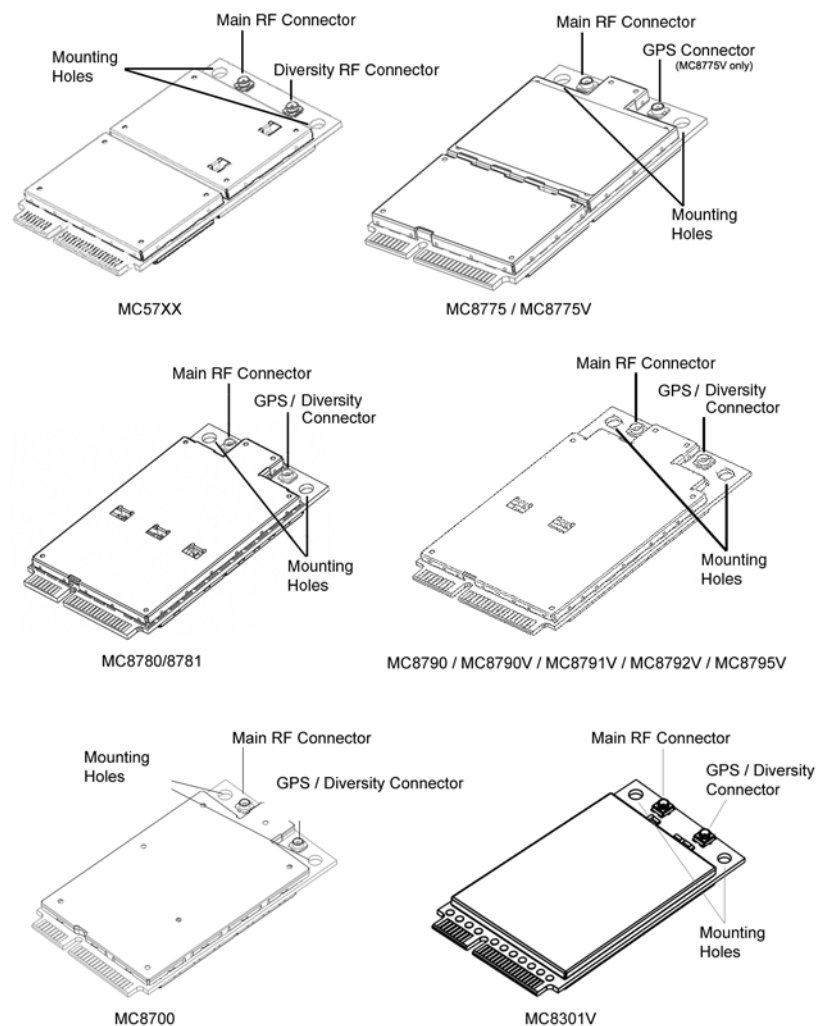
Figure 3-1: Antenna connection points and mounting holes

Ground connection

When connecting the module to system ground:

- Prevent noise leakage by establishing a very good ground connection to the module through the host connector.
- Connect to system ground using the two mounting holes at the top of the module (as shown in [Figure 3-1](#)).
- Minimize ground noise leakage into the RF. Depending on the host board design, noise could *potentially* be coupled to the module from the host board. This is mainly an issue for host designs that have signals traveling along the length of the module, or circuitry operating at both ends of the module interconnects.

Note: Values in this guide are taken from the appropriate product specification documents (PSDs) (listed in [Related documents, page 11](#)) — in the case of a discrepancy between this document and the relevant PSD, use the value listed in the PSD.

Shielding

The module is fully shielded to protect against EMI and to ensure compliance with FCC Part 15 - “Radio Frequency Devices” (or equivalent regulations in other jurisdictions).

Note: The module shields must NOT be removed.

Antenna and cabling

When selecting the antenna and cable, it is critical to RF performance to match antenna gain and cable loss.

Choosing the correct antenna and cabling

Consider the following points for proper matching of antennas and cabling:

- The antenna (and associated circuitry) should have a nominal impedance of $50\ \Omega$ with a return loss ≤ 10 dB across each frequency band of operation.
- The system gain value affects both radiated power *and* regulatory (FCC, IC, CE, etc.) test results.

Developing custom antennas

Consider the following points when developing custom-designed antennas:

- A skilled RF engineer should do the development to ensure that the RF performance is maintained.
- Identify the bands that need to be supported, particularly when both the MC57xx and MC8xxx will be installed in the same platform. In this case, you may want to develop separate antennas for maximum performance.

Determining the antenna’s location

Consider the following points when deciding where to put the antenna:

- Antenna location may affect RF performance. Although the module is shielded to prevent interference in most applications, the placement of the antenna is still very important — if the host device is insufficiently shielded, high levels of broadband or spurious noise can degrade the module’s performance.
- Connecting cables between the module and the antenna must have $50\ \Omega$ impedance. If the impedance of the module is mismatched, RF performance is reduced significantly.

Note: These modules are based on ZIF (Zero Intermediate Frequency) technologies; when performing EMC (Electromagnetic Compatibility) tests, there are no IF (Intermediate Frequency) components from the module to consider.

Note: Values in this guide are taken from the appropriate product specification documents (PSDs) (listed in [Related documents](#), page 11) — in the case of a discrepancy between this document and the relevant PSD, use the value listed in the PSD.

- Antenna cables should be routed, if possible, away from noise sources (switching power supplies, LCD assemblies, etc.). If the cables are near the noise sources, the noise may be coupled into the RF cable and into the antenna.

Disabling the diversity antenna

- MC57xx — If your host device is not designed to use the MC57xx module's diversity antenna, terminate the interface with a 50 Ω load.
- MC8301V/MC8780/MC8781/MC8790/MC8790V/MC8791V/MC8792V/MC8795V/MC8700 — Use the AT command **!RXDEN=0** to disable receive diversity or **!RXDEN=1** to enable receive diversity.

Interference and sensitivity

Several sources of interference can affect the RF performance of the module (RF desense). Common sources include power supply noise and device-generated RF.

RF desense can be addressed through a combination of mitigation techniques and radiated sensitivity measurement.

Power supply noise

Noise in the power supply can lead to noise in the RF signal.

The power supply ripple limit for the module is no more than 200 mVp-p 1 Hz to 100 kHz. This limit includes voltage ripple due to transmitter burst activity.

Interference from other wireless devices

Wireless devices operating inside the host device can cause interference that affects the module.

To determine the most suitable locations for antennas on your host device, evaluate each wireless device's radio system, considering the following:

- Any harmonics, sub-harmonics, or cross-products of signals generated by wireless devices that fall in the module's Rx range may cause spurious response, resulting in decreased Rx performance.
- The Tx power and corresponding broadband noise of other wireless devices may overload or increase the noise floor of the module's receiver, resulting in Rx desense.

Note: The module can cause interference with other devices such as hearing aids and on-board speakers.

Wireless devices such as the Mini Card transmit in bursts (pulse transients) for set durations (RF burst frequencies). Hearing aids and speakers convert these burst frequencies into audible frequencies, resulting in audible noise.

The severity of this interference depends on the closeness of the other antennas to the module's antenna. To determine suitable locations for each wireless device's antenna, thoroughly evaluate your host device's design.

Device-generated RF

All electronic computing devices generate RF interference that can negatively affect the receive sensitivity of the module.

The proximity of host electronics to the antenna in wireless devices can contribute to decreased Rx performance. Components that are most likely to cause this include:

- Microprocessor and memory
- Display panel and display drivers
- Switching-mode power supplies

These and other high-speed devices (in particular, the processor) can decrease Rx performance because they run at frequencies of tens of MHz. The rapid rise and fall of these clock signals generates higher-order harmonics that often fall within the operating frequency band of the module, affecting the module's receive sensitivity.

Example

On a sub-system running at 40 MHz, the 22nd harmonic falls at 880 MHz, which is within the cellular receive frequency band.

Note: In practice, there are usually numerous interfering frequencies and harmonics. The net effect can be a series of desensitized receive channels.

4: Audio Interface

Note: Values in this guide are taken from the appropriate product specification documents (PSDs) (listed in [Related documents, page 11](#)) — in the case of a discrepancy between this document and the relevant PSD, use the value listed in the PSD.

The MC5725V/MC5727V/ MC5728V /MC8301V/MC8775V/ MC8790V/MC8791V/MC8792V/MC8795V modules support six audio modes that may be required by a host audio system:

- Handset
- Headset
- Car kit
- Speakerphone
- AUX (MC5727V/ MC5728V modules are preconfigured for HAC [Hearing Aid Compatibility])
- TTY

The modules support both a differential analog interface and PCM digital audio, and allow dynamic run-time selection of the appropriate mode.

[Table 4-1](#) summarizes the key audio features of these modules.

Table 4-1: Audio features

Feature	Transmit	Receive
Gain (adjustable)	MC5725V: <ul style="list-style-type: none"> • Up to +16 dB analog gain. MC5727V: <ul style="list-style-type: none"> • MIC_AMP1: Programmable to 0 dB or +24 dB. • MIC_AMP2: Programmable from -6 dB to +25.5 dB in steps of 1.5 dB. MC5728V: <ul style="list-style-type: none"> • Programmable to 0 dB or +24 dB. MC8301V/MC8775V/MC8790V/MC8791V/ MC8792V/MC8795V: <ul style="list-style-type: none"> • Up to +48.5 dB analog gain available (when the analog interface is selected). 	Up to +12 dB
Filtering stages	Several adjustable high-pass and slope filters	High-pass filter
Noise suppression	Supported	n/a
Echo cancellation	Configurable for each audio mode (headset, handset, speakerphone, and car kit)	n/a
Output driver stage	n/a	Supported

Table 4-1: Audio features (Continued)

Feature	Transmit	Receive
FIR (Finite Impulse Response) filtering	MC8xxx: <ul style="list-style-type: none"> Option of providing 13 tap FIR filtering for receive and transmit paths to equalize the acoustic response of the speaker and microphone elements. 	
Audio pass band	300 Hz–3.4 kHz	

These modules are intended to serve as an integral component of a more complex audio system—for example, a PDA with a separate codec interfaced to the Host Application processor.

Usually, the interface between the module and the host audio system is set to line-level amplitudes with no transducer considerations. The responsibility of the module codec or host codec for special functions is detailed in [Table 4-2](#).

Table 4-2: Functions - responsibility codecs

Function	Responsible Codec
Phone oriented (e.g., echo cancellation, FIR filtering)	Module codec
Path-switching	Host codec
Transducer interfaces	Host codec
Adjustable gain / volume settings	Either
DTMF / ringer tone generation	Either
Mixing	Host codec

System block diagrams

Note: When integrating the module into your host platform, make sure the module has sufficient shielding to prevent RF interference.

MC5725V / MC5727V system block

[Figure 4-1](#) represents the MC5725V / MC5727V module’s audio system block, and includes the following features:

- Module interconnects are shown on the left side of the diagram. The audio interface uses the signals:
 - MIC_P / MIC_N
 - SPK_P / SPK_N

Note: Make sure the host device includes DC blocking capacitors on the Audio In lines – the module does not include series capacitors.

- Dynamic ranges for each programmable gain stage are listed, with the following constraints:
 - MIC_AMP1 is programmable in discrete steps only
 - MIC_AMP2 (MC5727V only) is programmable in discrete steps only
 - CodecSTGain, when set to the minimum setting, effectively mutes sidetone in the module codec

Figure 4-1: MC5725V / MC5727V Audio system block

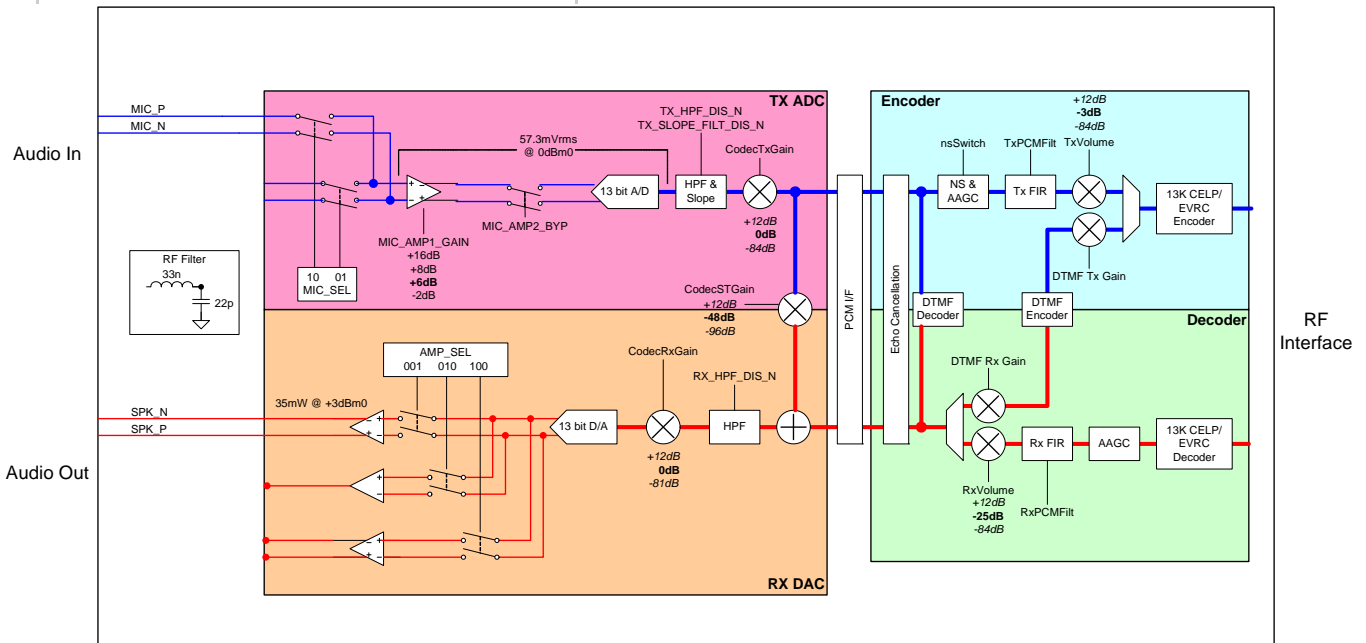

MC5728V system block

Figure 4-2 represents the MC5728V module’s audio system block, and includes the following features:

- Module interconnects are shown on the left side of the diagram. The audio interface uses the signals:
 - MIC_P / MIC_N
 - SPK_P / SPK_N
- Dynamic ranges for each programmable gain stage are listed, with the following constraints:
 - MIC_AMP1 is programmable to 0 dB or +24 dB only
 - CodecSTGain, when set to the minimum setting, effectively mutes sidetone in the module codec

Note: Make sure the host device includes DC blocking capacitors on the Audio In lines – the module does not include series capacitors.

Figure 4-2: MC5728V Audio system block

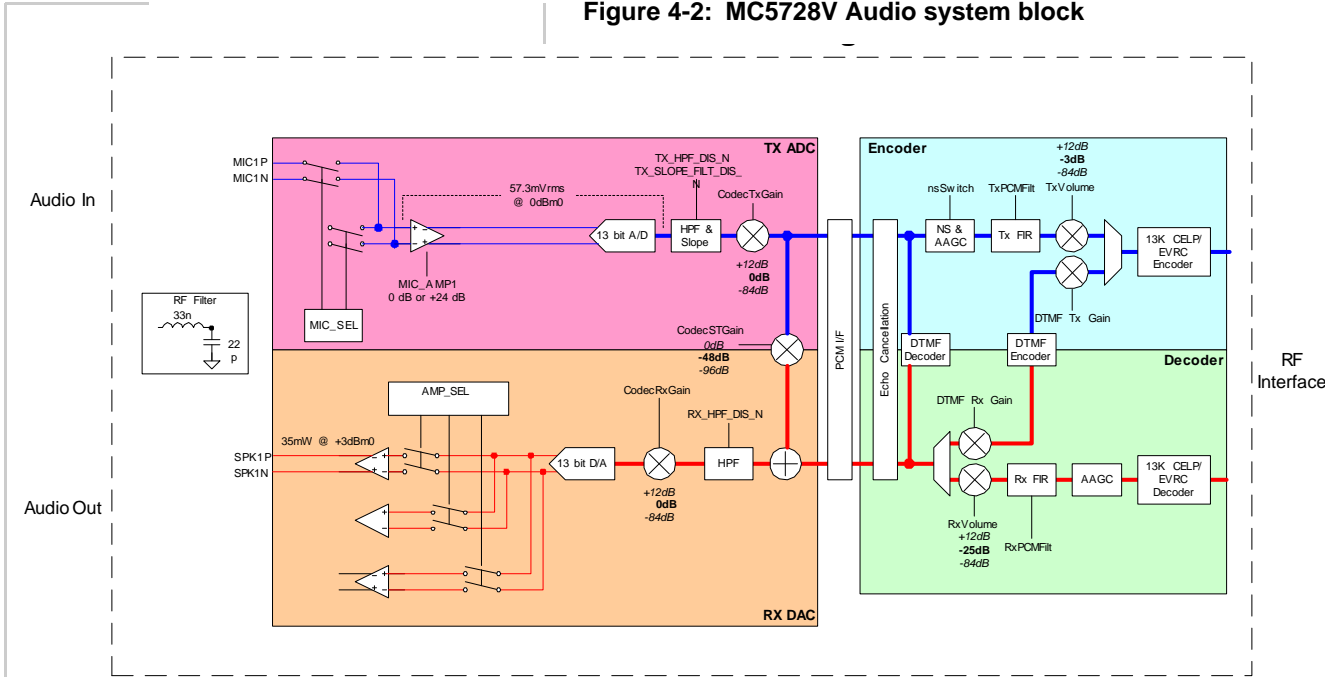

**MC8301V/MC8775V/MC8790V/MC8791V/MC8792V/
MC8795V system block**

Figure 4-3 represents the MC8301V/MC8775V/MC8790V/MC8791V/MC8792V/MC8795V module's audio system block, and includes the following features:

- Module interconnects are shown on the left side of the diagram. The analog audio interface uses the signals:
 - MIC_P / MIC_N
 - SPK_P / SPK_N
- The digital PCM audio interface uses the signals:
 - PCM_CLK
 - PCM_DIN
 - PCM_DOUT
 - PCM_SYNC
- Dynamic ranges for each programmable gain stage are listed, with the following constraints:
 - MIC_AMP1 is programmable in 1.5 dB steps
 - CodecSTGain, when set to the minimum setting, effectively mutes sidetone in the module codec
- When PCM audio is selected, the RX DAC and TX ADC blocks are bypassed – the external PCM codec controls transmit gain, receive gain, and sidetone gain.

Note: Make sure the host device includes DC blocking capacitors on the analog Audio In lines – the module does not include series capacitors.

Note: Data mixing is not supported. If mixing of voice signal is required, it must be done by the host processor.

Figure 4-3: MC8301V/MC8775V/MC8790V/MC8791V/MC8792V/MC8795V Audio system block

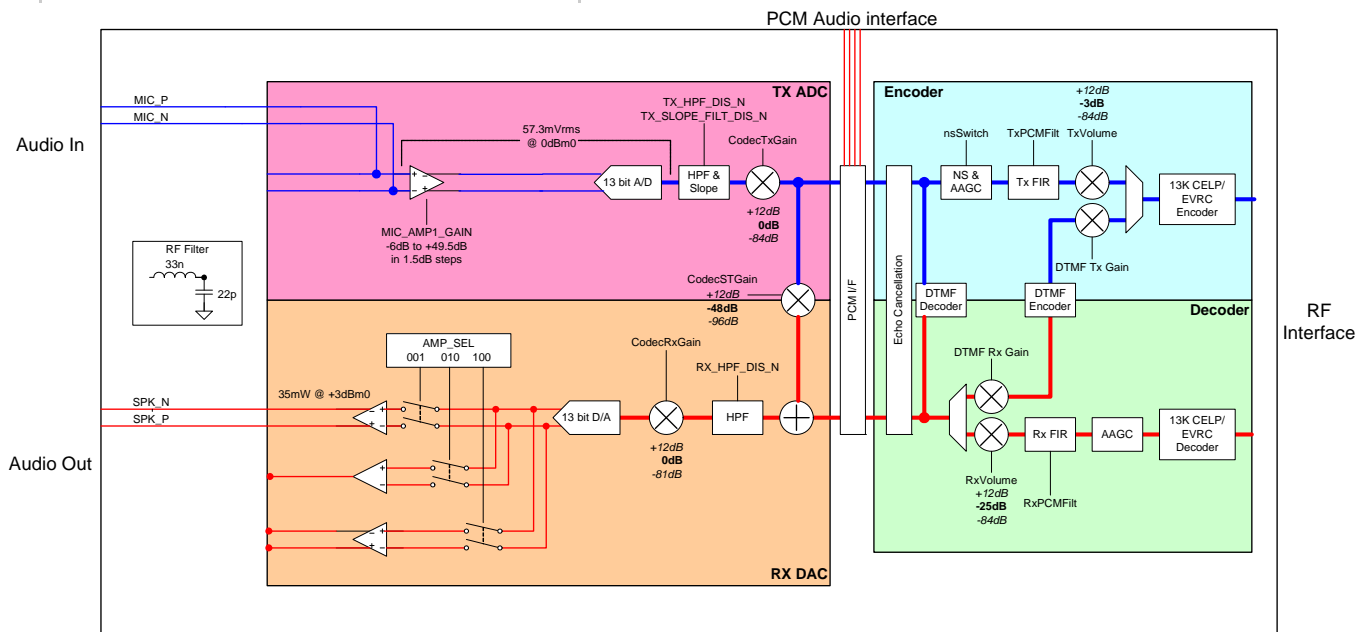

Modes of operation

These modules support six operational modes: headset, handset, car kit, speakerphone, AUX¹, and TTY—end products can use any combination of these modes.

The host device must use host-modem messaging to tell the module which mode to use for each call.

Sidetone support

The sidetone path mixes the near-end transmit voice to the near-end receive. This gives the near-end user some feedback that indicates that the call is up and that the audio system is functioning.

The sidetone path can be enabled in either the PDA codec or the Mini Card modem—each path is equally valid. It should *not* be added to both devices, and for speakerphone or car kit applications, *both* sidetone paths should be disabled.

1. (MC5727V/MC5728V modules are preconfigured for HAC [Hearing Aid Compatibility]).

The typical handset sidetone is 12 dB below transmit voice levels.

For Handset and Headset mode, the threshold of pain (+120 dBSPL) *must not* be exceeded at the maximum volume setting. A good target for the medium volume setting is +94 dBSPL, as this is a typical level for conversational speech.

Most audio gain should be added to the host audio front end (within the PDA style codec gain blocks or amplifiers between the host codec and transducers). Refer to the appropriate Mini Card Product Specification Document for reference levels on the modem receive and transmit side.

Echo cancellation support

The Mini Card offers four modes of echo cancellation to support unique end-unit audio capabilities (echo cancellation can also be turned off completely). All echo cancellation is near-end (mobile TX) cancellation only. The network provides some level of far-end echo cancellation.

Table 4-3: Echo cancellation details

Mode	Details
Handset	<ul style="list-style-type: none"> • Short echo path (<16 ms travel time from speaker to microphone) • Handset design requires good isolation between speaker and microphone • Echo canceller allows full-duplex conversation with absolute minimum echo
Headset	<ul style="list-style-type: none"> • Short echo path (<16 ms travel time from speaker to microphone) • Headset design may allow higher echo than handset mode—microphone and speaker are physically closer • More aggressive echo canceller algorithm allows full-duplex conversation on headsets with good isolation
Car kit	<ul style="list-style-type: none"> • Long echo path (<64 ms travel time from speaker to microphone) • Loud echo • For use with hands-free car kit or speakerphone applications with mild distortion

Table 4-3: Echo cancellation details

Mode	Details
Speakerphone	<ul style="list-style-type: none"> • Long echo path (<64 ms travel time from speaker to microphone) • Loud echo • For use with speakerphone applications with high distortion • Half-duplex algorithm, very aggressive in near-end Tx muting to eliminate transmitted echo
Off	

Audio signal interface

The differential microphone input offers superior noise rejection performance to the single-ended approach. The termination of the differential pair rejects common signals (such as noise). The pair should be routed together for optimal noise rejection. Since MIC_P and MIC_N are high impedance inputs, it is important to isolate these from possible noise sources (toggling digital lines with fast edges).

The speaker interface can be single-ended or differential depending on product. Single-ended speaker outputs rely on modem ground as an audio reference.

The audio passband for both receive and transmit paths (speaker and microphone) extends from 300 Hz to 3.4 kHz. A programmable sidetone with a range from mute to unity gain is available for both headset and main audio paths. Sidetone should be muted for speakerphone use.

Note that certain carriers now require use of hearing-aid compatible transducers in a handset design. The Primary audio path can be interfaced directly to such devices. Refer to ANSI C63.19 for details regarding reduced RF emissions ("U3 rating") and inductive / telecoil coupling ("U3T" rating) devices.

Table 4-4: Primary audio signal interface

Signal	Pin #	Type	Directions	Description
MIC_P	1	Analog	Input	Non-inverted microphone input (+)
MIC_N	3	Analog	Input	Inverted microphone input (-)

Table 4-4: Primary audio signal interface

Signal	Pin #	Type	Directions	Description
SPK_P	5	Analog	Output	Non-inverted speaker output (+)
SPK_N	7	Analog	Output	Inverted speaker output (-)

Table 4-5: PCM digital audio signal interface

Signal	Pin #	Type	Directions	Description
PCM_CLK	45	Digital	Output	PCM clock
PCM_DIN	47	Digital	Input (internal pull-down)	PCM data in
PCM_DOUT	49	Digital	Output	PCM data out
PCM_SYNC	51	Digital	Input (internal pull-down)	PCM sync

Audio function partitioning

These phone-oriented functions are usually under module control:

- FIR filters—both transmit and receive path
- Noise suppression—required due to high sensitivity and gain in transmit path
- Echo cancellation—different for each audio path and environment (handset, headset, car kit, speakerphone)
- High pass filtering / slope filtering functions—required per phone acoustic requirements
- AGC (Automatic Gain Control)—normalizes audio volumes in varying acoustic environments
- DTMF tones—the generation and detection of DTMF tones is required in both directions of the phone interface
- Comfort noise—low level noise injected into receiver path for user "connection" experience
- Simple ringers—digital and analog tones, melody ringers, MIDI with limited memory storage

These functions are typically performed in the host codec:

- Voice Memo—performed by the host if significant memory storage is required
- Polyphonic ringtone—host often supports WAV, MIDI formats with significant memory storage
- Audio path switching—turn on audio path depending on user interface selection, or headset detection

- Audio path mixing—required for voice memo recording and playback via multiple audio paths
- Transducer interface—host provides acoustic drivers, must occur outside of path switching and mixing

These functions can be performed in either host or module codec, depending on balance of component selection and engineering resources:

- Volume settings—adjustable gain settings based on user interface selections
- Sidetone—careful placement of sidetone gain control is required to prevent the need to adjust sidetone gain with varying volume settings

5: Host / Module Interfaces

LED output

The module drives the LED output according to the *PCI-Express Mini Card specification* (summarized in [Table 5-1](#), below).

Table 5-1: LED states

State	Indicates	Characteristics
Off	Module is not powered.	Light is off.
On	Module is powered and connected, but not transmitting or receiving.	Light is on.
Slow blink	Module is powered and searching for a connection.	LED is flashing at a steady, slow rate. <ul style="list-style-type: none"> • 250 ms \pm 25% ON period • 0.2 Hz \pm 25% blink rate
Faster blink	Module is transmitting or receiving.	LED is flashing at a steady, faster rate. <ul style="list-style-type: none"> • Approximately 3 Hz blink rate <hr/> <p><i>Note: MC572x modules support customer-defined LED controls.</i></p> <hr/>

Figure 5-1: Example LED

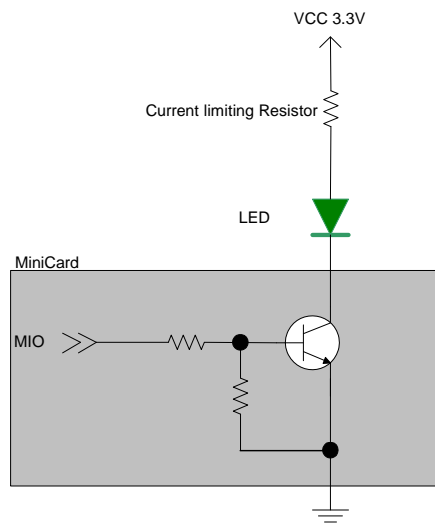

»» | A: Regulatory Information

Important notice

Because of the nature of wireless communications, transmission and reception of data can never be guaranteed. Data may be delayed, corrupted (i.e., have errors) or be totally lost. Although significant delays or losses of data are rare when wireless devices such as the Sierra Wireless modem are used in a normal manner with a well-constructed network, the Sierra Wireless modem should not be used in situations where failure to transmit or receive data could result in damage of any kind to the user or any other party, including but not limited to personal injury, death, or loss of property. Sierra Wireless and its affiliates accept no responsibility for damages of any kind resulting from delays or errors in data transmitted or received using the Sierra Wireless modem, or for failure of the Sierra Wireless modem to transmit or receive such data.

Safety and hazards

Do not operate your MC57xx / MC8xxx modem:

- In areas where blasting is in progress
- Where explosive atmospheres may be present including refuelling points, fuel depots, and chemical plants
- Near medical equipment, life support equipment, or any equipment which may be susceptible to any form of radio interference. In such areas, the MC57xx / MC8xxx modem **MUST BE POWERED OFF**. Otherwise, the MC57xx / MC8xxx modem can transmit signals that could interfere with this equipment.

In an aircraft, the MC57xx / MC8xxx modem **MUST BE POWERED OFF**. Otherwise, the MC57xx / MC8xxx modem can transmit signals that could interfere with various onboard systems and may be dangerous to the operation of the aircraft or disrupt the cellular network. Use of a cellular phone in an aircraft is illegal in some jurisdictions. Failure to observe this instruction may lead to suspension or denial of cellular telephone services to the offender, or legal action or both.

Some airlines may permit the use of cellular phones while the aircraft is on the ground and the door is open. The MC57xx / MC8xxx modem may be used normally at this time.

Important compliance information for North American users

The MC57xx / MC8xxx modem has been granted modular approval for mobile applications. Integrators may use the MC57xx / MC8xxx modem in their final products without additional FCC / IC (Industry Canada) certification if they meet the following conditions. Otherwise, additional FCC / IC approvals must be obtained.

1. At least 20 cm separation distance between the antenna and the user's body must be maintained at all times.
2. To comply with FCC / IC regulations limiting both maximum RF output power and human exposure to RF radiation, the maximum antenna gain including cable loss in a mobile-only exposure condition must not exceed 5 dBi in the cellular band and 4 dBi in the PCS band.
3. The MC57xx / MC8xxx modem and its antenna must not be co-located or operating in conjunction with any other transmitter or antenna within a host device.
4. A label must be affixed to the outside of the end product into which the MC57xx / MC8xxx modem is incorporated, with a statement similar to the following:
 - For MC5725 / MC5725V:
This device contains FCC ID: N7N-MC5725
This equipment contains equipment certified under IC: 2417C-MC5725
 - For MC5727 / MC5727V:
This device contains FCC ID: N7N-MC5727
This equipment contains equipment certified under IC: 2417C-MC5727
 - For MC5728V:
This device contains FCC ID: N7N-MC5728
This equipment contains equipment certified under IC: 2417C-MC5728
 - For MC8301V:
This device contains FCC ID: N7NMC8301
This equipment contains equipment certified under IC: 2417C-MC8301
 - For MC8775 / MC8775V:
This device contains FCC ID: N7NMC8775
This equipment contains equipment certified under IC: 2417C-MC8775
 - For MC8780:
This device contains FCC ID: N7NMC8780

- For MC8781:
This device contains FCC ID: N7NMC8781
This equipment contains equipment certified under IC: 2417C-MC8781
 - For MC8790 / MC8790V:
This device contains FCC ID: N7NMC8790
This equipment contains equipment certified under IC: 2417C-MC8790
 - For MC8792V:
This device contains FCC ID: N7NMC8792
This equipment contains equipment certified under IC: 2417C-MC8792
 - For MC8795V:
This device contains FCC ID: N7NMC8795
This equipment contains equipment certified under IC: 2417C-MC8795
 - For MC8700:
This device contains FCC ID: N7NMC8700
This equipment contains equipment certified under IC: 2417C-MC8700
5. A user manual with the end product must clearly indicate the operating requirements and conditions that must be observed to ensure compliance with current FCC / IC RF exposure guidelines.

The end product with an embedded MC57xx / MC8xxx modem may also need to pass the FCC Part 15 unintentional emission testing requirements and be properly authorized per FCC Part 15.

Note: If this module is intended for use in a portable device, you are responsible for separate approval to satisfy the SAR requirements of FCC Part 2.1093 and IC RSS-102.

EU regulatory conformity

Sierra Wireless hereby declares that the MC8301V, MC8775, MC8775V, MC8780, MC8790, MC8790V, MC8791V, MC8792V, MC8795V, and MC8700 modems conform with all essential requirements of Directive 1999/5/EC.

MC8301V:



MC8775, MC8775V, MC8780, MC8790, MC8790V, MC8791V, MC8792V:



MC8795V:

CE 0168

MC8700:

CE 0678

The Declaration of Conformity made under Directive 1999/5/EC is available for viewing at the following location in the EU community:

Sierra Wireless (UK), Limited
Lakeside House
1 Furzeground Way, Stockley Park East
Uxbridge, Middlesex
UB11 1BD
England

Brazil ANATEL homologation

(MC8790 somente) Este produto está homologado pela ANATEL, de acordo com os procedimentos regulamentados pela Resolução 242/2000, e atende aos requisitos técnicos aplicados.

Para maiores informações, consulte o site da ANATEL www.anatel.gov.br.

Modelo: MC8790



0688-09-1568



(01)07898912207166

»» B: Acronyms and Definitions

Table B-1: Acronyms and definitions

Acronym or term	Definition
AGC	Automatic Gain Control
BER	Bit Error Rate - a measure of receive sensitivity
BLER	Block Error Rate
Call Box	Base Station Simulator - Agilent E8285A or 8960, Rohde & Schwarz CMU200
CDMA	Code Division Multiple Access
dB	Decibel = $10 \times \log_{10} (P1/P2)$ <i>P1 is calculated power; P2 is reference power</i> Decibel = $20 \times \log_{10} (V1/V2)$ <i>V1 is calculated voltage, V2 is reference voltage</i>
dBm	Decibels, relative to 1 mW - Decibel(mW) = $10 \times \log_{10} (Pwr (mW)/1mW)$
DUT	Device Under Test
EDGE	Enhanced Data rates for GSM Evolution
EM	Embedded Module
ESD	ElectroStatic Discharge
FER	Frame Error Rate - a measure of receive sensitivity
GPRS	General Packet Radio Services
GPS	Global Positioning System
GSM	Global System for Mobile communications
Hz	Hertz = 1 cycle/second
inrush current	Peak current drawn when a device is connected or powered on
IS-2000	3G radio standards for voice and data (CDMA only)
IS-95	2G radio standards targeted for voice (cdmaONE)
LDO	Low Drop Out - refers to linear regulator

Table B-1: Acronyms and definitions

Acronym or term	Definition
MC5725 / MC5725V / MC5727 / MC5727V / MC5728V	Sierra Wireless Mini Cards used on CDMA networks
MC57xx	Any of the following CDMA Mini Cards: MC5725 / MC5725V / MC5727 / MC5727V / MC5728V
MC8301V / MC8775 / MC8775V / MC8780 / MC8781 / MC8790 / MC8790V / MC8791V / MC8792V / MC8795V / MC8700	Sierra Wireless Mini Cards used on GSM/UMTS networks
MC8xxx	Any of the following GSM/UMTS Mini Cards: MC8301V / MC8775 / MC8775V / MC8780 / MC8781 / MC8790 / MC8790V / MC8791V / MC8792V / MC8795V / MC8700
MHz	MegaHertz = 10E6 Hertz (Hertz = 1 cycle/second)
MIO	Module Input/Output
MPE	Maximum Permissible Exposure — the level of radiation to which a person may be exposed without hazardous effect or adverse biological changes
OTA	Over-The-Air or Radiated through the antenna
PCS	Personal Communication System - PCS spans the 1.9 GHz radio spectrum
RF	Radio Frequency
RMS	Root Mean Square
SA	Selective Availability
Sensitivity (Audio)	Measure of lowest power signal that the receiver can measure
Sensitivity (RF)	Measure of lowest power signal at the receiver input that can provide a prescribed BER / BLER / SNR value at the receiver output.
SIM	Subscriber Identity Module
SNR	Signal to Noise Ratio
SOF	Start of Frame - a USB function
UART	Universal Asynchronous Receiver Transmitter
UDK	Universal Development Kit (PCI Express Mini Card Dev Kit)

Table B-1: Acronyms and definitions

Acronym or term	Definition
UMTS	Universal Mobile Telecommunications System
USB	Universal Serial Bus
USIM	Universal Subscriber Identity Module
VCC3.3	3.3 V supply voltage
WCDMA	Wideband Code Division Multiple Access — In this document, the term “UMTS” is used instead of “WCDMA”.
XIM	In this document, XIM is used as part of the contact identifiers for the USIM interface (XIM_VCC, XIM_CLK, etc.).

Index

Numerics

1X
CDMA Standard 11

A

acronyms and definitions 41–43
airplane mode 17

antenna
connection and mounting points 21
connection considerations 20
custom, considerations 22
diversity antenna, disabling 23
limit, matching coaxial connections 20
location, considerations 22
matching, considerations 22
maximum cable loss 20

AT commands
3GPP specification, details 11
low power mode, setting 17
standard, MC57xx (reference document) 11
standard, MC8xxx (reference document) 13

AT commands, extended
MC57xx, reference 11
MC8xxx, reference 13

AT commands, standard
MC57xx, reference 11
MC8xxx, reference 13

audio
features, summary 25
functions, host-controlled 32
functions, module-controlled 32
functions, responsible codecs 26
interface 25–33
path mixing, host-controlled 33
path switching, host-controlled 32
PCM digital, signal interface 32
primary, signal interface 31
signal interface 31
system block diagram, MC5725V 26
system block diagram, MC5727V 26
system block diagram, MC5728V 27
system block diagram, MC8xxxV 28

audio modes, supported 29

audio pass band 26

audio passband, Rx and Tx 31

automatic gain control (AGC)
module-controlled 32

C

cable loss
antenna, maximum 20

car kit audio mode 25
car kit mode
echo cancellation 30
CDMA
1X Standard 11

CnS
MC57xx reference 11
MC8xxx reference 13
voice reference 13

codec
for audio functions 26
comfort noise
module-controlled 32

connection
grounding 21
connectors, required
EDGE mating (52-pin) 10
host-module 10
RF, Hirose 10
USIM 10

current
consumption, usage models 17

D

DCS 1800
RF parameters, MC8xxx 19
desense. See RF
disconnected, module power state 16
diversity antenna
disabling 23
DTMF
codec 26
module-controlled 32

E

echo cancellation
audio feature 25
codec 26
details 30
module-controlled 32
support, all modes 30
EDGE connector, manufacturers 10
EGSM 900
RF parameters, MC8xxx 19
electrostatic discharge. See ESD
ESD
protection requirements 15–16
testing techniques document (IEC-61000-4-2) 11

F

FCC

- regulations, relevant section 11
- filtering
 - high pass / slope filtering, module-controlled 32
- filtering stages, audio 25
- FIR filtering
 - audio feature 26
 - codec 26
 - module-controlled 32

G

- gain
 - codec 26
 - distribution, audio 30
 - limits, adjustable 25
- GPS band
 - RF parameters, MC8xxx 20
- grounding
 - connection considerations 21
- GSM 850
 - RF parameters, MC8xxx 19

H

- handset audio mode 25
- handset mode
 - echo cancellation 30
- handset audio mode 25
- headset mode
 - echo cancellation 30

I

- impedance
 - module-antenna 22
- interface
 - audio signal 31
- interference
 - device generated 24
 - power supply noise 23
 - wireless devices 23

L

- LED
 - example 36
 - states 35
- low power mode
 - setting, AT commands 17
- low power, module power state 17

M

- MC5725
 - AT reference (extended) 11
 - AT reference (standard) 11
 - CnS reference 11

- networks supported 9
- product specification 11
- MC5725V
 - AT reference (extended) 11
 - AT reference (standard) 11
 - audio interface, supported 25
 - CnS reference 11
 - networks supported 9
 - product specification 11
- MC5727
 - AT reference (extended) 11
 - AT reference (standard) 11
 - CnS reference 11
 - networks supported 9
 - product specification 12
- MC5727V
 - AT reference (extended) 11
 - AT reference (standard) 11
 - audio interface, supported 25
 - CnS reference 11
 - networks supported 9
 - product specification 12
- MC5728V
 - AT reference (extended) 11
 - AT reference (standard) 11
 - audio interface, supported 25
 - CnS reference 11
 - networks supported 9
 - product specification 12
- MC8301V
 - AT reference (extended), and MC8xxx 13
 - AT reference (standard), and MC8xxx 13
 - CnS reference, and MC8xxx 13
 - CnS voice reference, and MC8xxxV 13
 - networks supported 9
 - product specification 12
 - RF parameters 19
- MC8700
 - AT reference (extended), and MC8xxx 13
 - AT reference (standard), and MC8xxx 13
 - CnS reference, and MC8xxx 13
 - networks supported 9
 - product specification 12
 - RF parameters 19
- MC8775
 - AT reference (extended), and MC8xxx 13
 - AT reference (standard), and MC8xxx 13
 - CnS reference, and MC8xxx 13
 - networks supported 9
 - product specification 12
 - RF parameters 19
- MC8775V
 - AT reference (extended), and MC8xxx 13
 - AT reference (standard), and MC8xxx 13
 - audio interface, supported 25
 - CnS reference, and MC8xxx 13
 - CnS voice reference, and MC8xxxV 13
 - networks supported 9
 - product specification 12

- RF parameters [19](#)
 - MC8780
 - AT reference (extended), and MC8xxx [13](#)
 - AT reference (standard), and MC8xxx [13](#)
 - CnS reference, and MC8xxx [13](#)
 - networks supported [9](#)
 - product specification [12](#)
 - RF parameters [19](#)
 - MC8781
 - AT reference (extended), and MC8xxx [13](#)
 - AT reference (standard), and MC8xxx [13](#)
 - CnS reference, and MC8xxx [13](#)
 - networks supported [9](#)
 - product specification [12](#)
 - RF parameters [19](#)
 - MC8790
 - AT reference (extended), and MC8xxx [13](#)
 - AT reference (standard), and MC8xxx [13](#)
 - CnS reference, and MC8xxx [13](#)
 - networks supported [9](#)
 - product specification [12](#)
 - RF parameters [19](#)
 - MC8790V
 - AT reference (extended), and MC8xxx [13](#)
 - AT reference (standard), and MC8xxx [13](#)
 - audio interface, supported [25](#)
 - CnS reference, and MC8xxx [13](#)
 - CnS voice reference, and MC8xxxV [13](#)
 - networks supported [9](#)
 - product specification [12](#)
 - RF parameters [19](#)
 - MC8791V
 - AT reference (extended), and MC8xxx [13](#)
 - AT reference (standard), and MC8xxx [13](#)
 - audio interface, supported [25](#)
 - CnS reference, and MC8xxx [13](#)
 - CnS voice reference, and MC8xxxV [13](#)
 - networks supported [9](#)
 - product specification [12](#)
 - RF parameters [19](#)
 - MC8792V
 - AT reference (extended), and MC8xxx [13](#)
 - AT reference (standard), and MC8xxx [13](#)
 - audio interface, supported [25](#)
 - CnS reference, and MC8xxx [13](#)
 - CnS voice reference, and MC8xxxV [13](#)
 - networks supported [9](#)
 - product specification [12](#)
 - RF parameters [19](#)
 - MC8795V
 - AT reference (extended), and MC8xxx [13](#)
 - AT reference (standard), and MC8xxx [13](#)
 - audio interface, supported [25](#)
 - CnS reference, and MC8xxx [13](#)
 - CnS voice reference, and MC8xxxV [13](#)
 - networks supported [9](#)
 - product specification [12](#)
 - RF parameters [19](#)
 - Mini Card
 - Dev Kit Quick Start Guide [13](#)
 - PCI Express Specification [13](#)
 - See also MC5725, MC5725V, MC5727, MC5727V, MC5728V, MC8775, MC8775V, MC8780, MC8781, MC8790, MC8790V, MC8791V, MC8792V, MC8795V, MC8700
 - mixing
 - codec [26](#)
- ## N
- networks
 - supported, by module type [9](#)
 - noise
 - leakage, minimizing [21](#)
 - RF interference, power supply [23](#)
 - noise suppression
 - audio feature [25](#)
 - module-controlled [32](#)
 - normal, module power state [17](#)
- ## O
- off, module power state [17](#)
 - output driver stage, audio feature [25](#)
- ## P
- path switching
 - codec [26](#)
 - PCI Express
 - Mini Card specification [13](#)
 - PCM digital audio, signal interface [32](#)
 - PCS 1900
 - RF parameters, MC8xxx [19](#)
 - polyphonic ringtone
 - host-controlled [32](#)
 - power
 - default state [17](#)
 - disconnected, characteristics [16](#)
 - normal, characteristics [17](#)
 - off, characteristics [17](#)
 - required supply voltage [15](#)
 - signals, overview [15](#)
 - state, disconnected [16](#)
 - state, low power [17](#)
 - state, normal [17](#)
 - state, off [17](#)
 - supply, RF interference [23](#)
 - supply, ripple limit [23](#)
 - product specification (PSD) [11](#), [12](#)
 - PSD (Product Specification Document) [11](#), [12](#)
- ## R
- regulatory information [37–40](#)
 - Brazil [40](#)

- EU [39](#)
- FCC [38](#)
- limitation of liability [37](#)
- safety and hazards [37](#)
- RF
 - antenna cable loss, maximum [20](#)
 - antenna connection, considerations [20](#)
 - cable type, required [10](#)
 - desense
 - device-generated [24](#)
 - interference
 - other devices [24](#)
 - power supply [23](#)
 - wireless devices [23](#)
 - parameters
 - MC8xxx [19](#)
 - parameters, MC8xxx
 - DCS 1800 [19](#)
 - EGSM 900 [19](#)
 - GPS [20](#)
 - GSM 850 [19](#)
 - PCS 1900 [19](#)
 - UMTS 1900 [19](#)
 - UMTS 2100 [19](#)
 - UMTS 850 [19, 20](#)
- ringer tone
 - codec [26](#)
- ringers
 - module-controlled [32](#)
- ringtone, polyphonic
 - host-controlled [32](#)
- S**
 - shielding
 - module, compliance [22](#)
 - sidetone
 - responsible codec [33](#)
 - support [29](#)
 - SIM
 - testing methods, MS conformance specification [13](#)
 - See also USIM
 - speakerphone audio mode [25](#)
 - speakerphone mode
 - echo cancellation [31](#)
 - system block
 - MC5725V, audio [26](#)
 - MC5727V, audio [26](#)
 - MC5728V, audio [27](#)
 - MC8xxxV, audio [28](#)

T

- testing
 - ESD immunity, techniques document (IEC-61000-4-2) [11](#)
- transducer interface
 - host-controlled [33](#)
- transducer interfaces
 - codec [26](#)

U

- UDK (Universal Development Kit)
 - components, included [9](#)
- UMTS 1900
 - RF parameters, MC8xxx [19](#)
- UMTS 2100
 - RF parameters, MC8xxx [19](#)
- UMTS 850
 - RF parameters, MC8xxx [19, 20](#)
- Universal Development Kit (UDK)
 - components, included [9](#)
- Universal Serial Bus. See USB.
- usage models
 - current consumption [17](#)
- USB
 - specification [13](#)
- USIM
 - connector type, required [10](#)

V

- voice memo
 - host-controlled [32](#)
- volume, setting
 - responsible codec [33](#)

W

- W_Disable#
 - Normal state [17](#)
 - off state [17](#)

Z

- ZIF (Zero Intermediate Frequency) [23](#)

